

FCC Test Report

Product Name	TABLET PC
Model No	PA-501
FCC ID.	2ABTU-PA-501

Applicant	RuggON Corporation
Address	3F., No.10, Ln. 181, Sec. 2, Jiuzong Rd., Neihu Dist., Taipei City , Taiwan

Date of Receipt	Apr. 10, 2015
Issue Date	Jul. 08, 2015
Report No.	1540249R-RFUSP26V00
Report Version	V1.0



The test results relate only to the samples tested.

The test results shown in the test report are traceable to the national/international standard through the calibration report of the equipment and evaluated measurement uncertainty herein.

This report must not be used to claim product endorsement by TAF or any agency of the government.

The test report shall not be reproduced without the written approval of QuieTek Corporation.

Test Report

Issue Date: Jul. 08, 2015

Report No.: 1540249R-RFUSP26V00



Product Name	TABLET PC
Applicant	RuggON Corporation
Address	3F., No.10, Ln. 181, Sec. 2, Jiuzong Rd., Neihu Dist., Taipei City , Taiwan
Manufacturer	Ubiqconn Technology,Inc.
Model No.	PA-501
FCC ID.	2ABTU-PA-501
EUT Rated Voltage	AC 100-240V, 50-60Hz
EUT Test Voltage	AC 120V/60Hz
Trade Name	RuggON
Applicable Standard	FCC CFR Title 47 Part 15 Subpart C: 2014 ANSI C63.4: 2014, ANSI C63.10: 2013 KDB 558074 D01 DTS Meas Guidance v03r02
Test Result	Complied

Documented By : Jinn Chen
(Senior Adm. Specialist / Jinn Chen)

Tested By : Eason chen
(Engineer / Eason Chen)

Approved By : [Signature]
(Director / Vincent Lin)

TABLE OF CONTENTS

Description	Page
1. GENERAL INFORMATION	5
1.1. EUT Description.....	5
1.2. Operational Description	7
1.3. Tested System Details.....	8
1.4. Configuration of Tested System	8
1.5. EUT Exercise Software	8
1.6. Test Facility	9
2. Conducted Emission.....	10
2.1. Test Equipment.....	10
2.2. Test Setup	10
2.3. Limits	11
2.4. Test Procedure	11
2.5. Uncertainty	11
2.6. Test Result of Conducted Emission.....	12
3. Peak Power Output	14
3.1. Test Equipment.....	14
3.2. Test Setup	14
3.3. Limits	14
3.4. Test Procedure	14
3.5. Uncertainty	14
3.6. Test Result of Peak Power Output.....	15
4. Radiated Emission.....	18
4.1. Test Equipment.....	18
4.2. Test Setup	18
4.3. Limits	19
4.4. Test Procedure	20
4.5. Uncertainty	20
4.6. Test Result of Radiated Emission.....	21
5. RF antenna conducted test.....	33
5.1. Test Equipment.....	33
5.2. Test Setup	33
5.3. Limits	33
5.4. Test Procedure	33
5.5. Uncertainty	34
5.6. Test Result of RF antenna conducted test.....	35
6. Band Edge	38
6.1. Test Equipment.....	38
6.2. Test Setup	38
6.3. Limits	39
6.4. Test Procedure	39
6.5. Uncertainty	39
6.6. Test Result of Band Edge	40

7.	Occupied Bandwidth.....	52
7.1.	Test Equipment.....	52
7.2.	Test Setup	52
7.3.	Limits	52
7.4.	Test Procedure	52
7.5.	Uncertainty	52
7.6.	Test Result of Occupied Bandwidth	53
8.	Power Density	62
8.1.	Test Equipment.....	62
8.2.	Test Setup	62
8.3.	Limits	62
8.4.	Test Procedure	62
8.5.	Uncertainty	62
8.6.	Test Result of Power Density	63
9.	EMI Reduction Method During Compliance Testing	72

Attachment 1: EUT Test Photographs

Attachment 2: EUT Detailed Photographs

1. GENERAL INFORMATION

1.1. EUT Description

Product Name	TABLET PC
Trade Name	RuggON
Model No.	PA-501
FCC ID.	2ABTU-PA-501
Frequency Range	2412-2462MHz for 802.11b/g/n-20BW
Number of Channels	802.11b/g/n-20MHz: 11
Data Speed	802.11b: 1-11Mbps, 802.11g: 6-54Mbps, 802.11n: up to 72.2Mbps
Type of Modulation	802.11b:DSSS (DBPSK, DQPSK, CCK) 802.11g/n:OFDM (BPSK, QPSK, 16QAM, 64QAM)
Antenna Type	PIFA Antenna
Antenna Gain	Refer to the table "Antenna List"
Channel Control	Auto
Power Adapter	MFR: FSP, M/N: FSP065-REB Input: 100-240V~1.5A, 50-60Hz Output: 19V $\overline{=}$ 3.42A Cable Out: Non-shielded, 1.8m

Antenna List

No.	Manufacturer	Part No.	Antenna Type	Peak Gain
1	Ethertronics Inc.	5001791 (Main) 5001799 (Aux)	PIFA	3.8dBi for 2.4 GHz

Note: The antenna of EUT is conforming to FCC 15.203.

802.11b/g/n-20MHz Center Frequency of Each Channel:

Channel	Frequency	Channel	Frequency	Channel	Frequency	Channel	Frequency
Channel 01:	2412 MHz	Channel 02:	2417 MHz	Channel 03:	2422 MHz	Channel 04:	2427 MHz
Channel 05:	2432 MHz	Channel 06:	2437 MHz	Channel 07:	2442 MHz	Channel 08:	2447 MHz
Channel 09:	2452 MHz	Channel 10:	2457 MHz	Channel 11:	2462 MHz		

Note:

1. The EUT is a TABLET PC with a built-in 2.4GHz WLAN and Bluetooth transceiver, this report for WLAN.
2. Regarding to the operation frequency, the lowest, middle and highest frequency are selected to perform the test.
3. At result of pretests, module supports dual-channel transmission, only the worst case is shown in the report.
4. Lowest and highest data rates are tested in each mode. Only worst case is shown in the report. (802.11b is 1Mbps 、 802.11g is 6Mbps 、 802.11n(20M-BW) is 7.2Mbps)
5. These tests are conducted on a sample for the purpose of demonstrating compliance of 802.11b/g/n transmitter with Part 15 Subpart C Paragraph 15.247 of spread spectrum devices.
6. The radiation measurements are performed in X, Y, Z axis positioning. Only the worst case is shown in the report.

Test Mode:	Mode 1: Transmit (802.11b 1Mbps)
	Mode 2: Transmit (802.11g 6Mbps)
	Mode 3: Transmit (802.11n MCS0 7.2Mbps 20M-BW)

1.3. Tested System Details

The types for all equipment, plus descriptions of all cables used in the tested system (including inserted cards) are:

	Product	Manufacturer	Model No.	Serial No.	Power Cord
(1)	Notebook PC	DELL	PPT	N/A	Non-Shielded, 0.8m
(2)	Monitor	DELL	ST2320L	N/A	N/A
(3)	FLASH	Transcend	JetFlash110	155422-2931	Non-Shielded, 1.8m
(4)	Earphone	AIWA	N/A	N/A	N/A

Signal Cable Type	Signal cable Description
A	RS-232 Cable
B	HDMI Cable
C	Earphone Cable
D	Micro USB Cable
E	RJ45 Cable

1.4. Configuration of Tested System

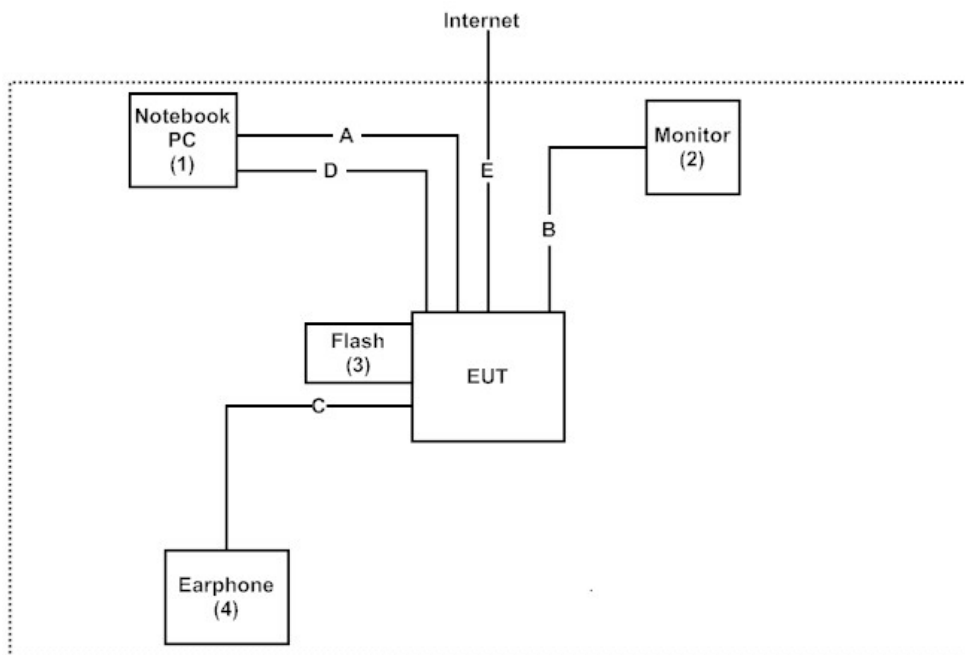

1.5. EUT Exercise Software

- 1 Setup the EUT as shown in Section 1.4.
- 2 Execute software “Terminal Euulator V1.0.45” on the Notebook PC.
- 3 Configure the test mode, the test channel, and the data rate.
- 4 Press “OK” to start the continuous Transmit.
- 5 Verify that the EUT works properly.

1.6. Test Facility

Ambient conditions in the laboratory:

Items	Required (IEC 68-1)	Actual
Temperature (°C)	15-35	20-35
Humidity (%RH)	25-75	50-65
Barometric pressure (mbar)	860-1060	950-1000

The related certificate for our laboratories about the test site and management system can be downloaded from

QuieTek Corporation's Web Site: <http://www.quietek.com/chinese/about/certificates.aspx?bval=5>

The address and introduction of Quietek Corporation's laboratories can be founded in our Web site:

<http://www.quietek.com/>

Site Description: File on
 Federal Communications Commission
 FCC Engineering Laboratory
 7435 Oakland Mills Road
 Columbia, MD 21046
 Registration Number: 92195

Site Name: Quietek Corporation
 Site Address: No.5-22, Ruishukeng,
 Linkou Dist. New Taipei City 24451,
 Taiwan, R.O.C.
 TEL: 886-2-8601-3788 / FAX : 886-2-8601-3789
 E-Mail : service@quietek.com

FCC Accreditation Number: TW1014

2. Conducted Emission

2.1. Test Equipment

	Equipment	Manufacturer	Model No. / Serial No.	Last Cal.	Remark
X	Test Receiver	R & S	ESCS 30 / 825442/018	Sep., 2014	
X	Artificial Mains Network	R & S	ENV4200 / 848411/10	Feb., 2015	Peripherals
X	LISN	R & S	ESH3-Z5 / 825562/002	Feb., 2015	EUT
	DC LISN	Schwarzbeck	8226 / 176	Mar., 2015	EUT
X	Pulse Limiter	R & S	ESH3-Z2 / 357.8810.52	Feb., 2015	
	No.1 Shielded Room				

Note:

1. All equipments are calibrated every one year.
2. The test instruments marked by "X" are used to measure the final test results.

2.2. Test Setup

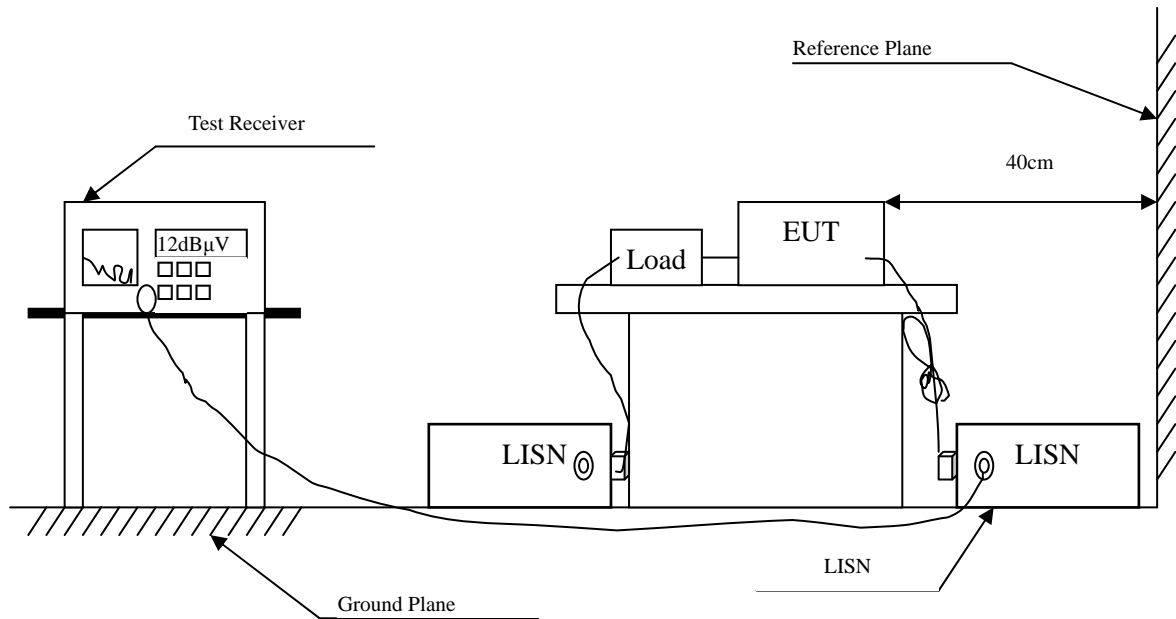

2.3. Limits

FCC Part 15 Subpart C Paragraph 15.207 (dBμV) Limit		
Frequency MHz	Limits	
	QP	AVG
0.15 - 0.50	66-56	56-46
0.50-5.0	56	46
5.0 - 30	60	50

2.4. Test Procedure

The EUT and simulators are connected to the main power through a line impedance stabilization network (L.I.S.N.). This provides a 50 ohm /50uH coupling impedance for the measuring equipment. The peripheral devices are also connected to the main power through a LISN that provides a 50ohm /50uH coupling impedance with 50ohm termination. (Please refers to the block diagram of the test setup and photographs.)

Both sides of A.C. line are checked for maximum conducted interference. In order to find the maximum emission, the relative positions of equipment and all of the interface cables must be changed according to ANSI C63.4: 2014 on conducted measurement.

Conducted emissions were invested over the frequency range from 0.15MHz to 30MHz using a receiver bandwidth of 9kHz.

2.5. Uncertainty

± 2.26 dB

2.6. Test Result of Conducted Emission

Product : TABLET PC
 Test Item : Conducted Emission Test
 Power Line : Line 1
 Test Mode : Mode 3: Transmit (802.11n MCS0 7.2Mbps 20M-BW) (2437MHz)

Frequency MHz	Correct Factor dB	Reading Level dBμV	Measurement Level dBμV	Margin dB	Limit dBμV
Line 1					
Quasi-Peak					
0.162	9.667	37.980	47.647	-18.010	65.657
0.263	9.664	23.860	33.524	-29.247	62.771
0.767	9.691	17.070	26.761	-29.239	56.000
2.880	9.795	23.910	33.705	-22.295	56.000
19.990	10.061	17.620	27.681	-32.319	60.000
24.002	10.058	26.490	36.548	-23.452	60.000
Average					
0.162	9.667	23.750	33.417	-22.240	55.657
0.263	9.664	10.660	20.324	-32.447	52.771
0.767	9.691	3.000	12.691	-33.309	46.000
2.880	9.795	12.780	22.575	-23.425	46.000
19.990	10.061	6.640	16.701	-33.299	50.000
24.002	10.058	24.090	34.148	-15.852	50.000

Note:

1. All Reading Levels are Quasi-Peak and average value.
2. “█” means the worst emission level.
3. Measurement Level = Reading Level + Correct Factor

Product : TABLET PC
 Test Item : Conducted Emission Test
 Power Line : Line 2
 Test Mode : Mode 3: Transmit (802.11n MCS0 7.2Mbps 20M-BW) (2437MHz)

Frequency MHz	Correct Factor dB	Reading Level dBμV	Measurement Level dBμV	Margin dB	Limit dBμV
Line 2					
Quasi-Peak					
0.162	9.667	37.980	47.647	-18.010	65.657
0.220	9.662	28.090	37.752	-26.248	64.000
0.771	9.692	17.490	27.182	-28.818	56.000
3.259	9.814	22.320	32.134	-23.866	56.000
20.880	10.205	16.490	26.695	-33.305	60.000
24.002	10.238	26.020	36.258	-23.742	60.000
Average					
0.162	9.667	26.920	36.587	-19.070	55.657
0.220	9.662	13.510	23.172	-30.828	54.000
0.771	9.692	4.120	13.812	-32.188	46.000
3.259	9.814	15.290	25.104	-20.896	46.000
20.880	10.205	10.970	21.175	-28.825	50.000
24.002	10.238	23.570	33.808	-16.192	50.000

Note:

1. All Reading Levels are Quasi-Peak and average value.
2. "■" means the worst emission level.
3. Measurement Level = Reading Level + Correct Factor

3. Peak Power Output

3.1. Test Equipment

	Equipment	Manufacturer	Model No./Serial No.	Last Cal.
X	Power Meter	Anritsu	ML2495A/6K00003357	May, 2015
X	Power Sensor	Anritsu	MA2411B/0738448	Jun, 2015

Note:

1. All equipments are calibrated with traceable calibrations. Each calibration is traceable to the national or international standards.
2. The test instruments marked with “X” are used to measure the final test results.

3.2. Test Setup

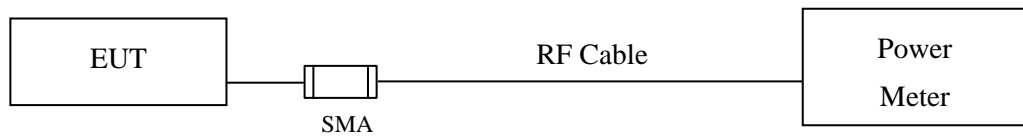

3.3. Limits

The maximum peak power shall be less 1 Watt.

3.4. Test Procedure

The EUT was tested according to DTS test procedure of KDB 558074 for compliance to FCC 47CFR 15.247 requirements. The maximum peak conducted output power using KDB 558074 D01 DTS Meas Guidance v03r02 section 9.1.2 PKPM1 Peak power meter method.

3.5. Uncertainty

± 1.27 dB

3.6. Test Result of Peak Power Output

Product : TABLET PC
 Test Item : Peak Power Output Data
 Test Site : No.3 OATS
 Test Mode : Mode 1: Transmit (802.11b 1Mbps)

Channel No	Frequency (MHz)	Average Power For different Data Rate (Mbps)				Peak Power	Required Limit	Result
		1	2	5.5	11	1		
		Measurement Level (dBm)						
01	2412	13.64	--	--	--	15.9	<30dBm	Pass
06	2437	13.95	13.84	13.76	13.65	16.19	<30dBm	Pass
11	2462	13.8	--	--	--	16.07	<30dBm	Pass

Note: Peak Power Output Value = Reading value on power meter + cable loss

Product : TABLET PC
 Test Item : Peak Power Output Data
 Test Site : No.3 OATS
 Test Mode : Mode 2: Transmit (802.11g 6Mbps)

Channel No	Frequency (MHz)	Average Power For different Data Rate (Mbps)								Peak Power	Required Limit	Result
		6	9	12	18	24	36	48	54			
		Measurement Level (dBm)										
01	2412	13.98	--	--	--	--	--	--	--	22.09	<30dBm	Pass
06	2437	13.83	13.74	13.65	13.59	13.48	13.32	13.26	13.21	21.89	<30dBm	Pass
11	2462	13.98	--	--	--	--	--	--	--	21.72	<30dBm	Pass

Note: Peak Power Output Value = Reading value on power meter + cable loss

Product : TABLET PC
 Test Item : Peak Power Output Data
 Test Site : No.3 OATS
 Test Mode : Mode 3: Transmit (802.11n MCS0 7.2Mbps 20M-BW)

Channel No	Frequency (MHz)	Average Power For different Data Rate (Mbps)								Peak Power	Required Limit	Result
		7.2	14.4	21.7	28.9	43.3	57.8	65	72.2			
		Measurement Level (dBm)										
01	2412	13.84	--	--	--	--	--	--	--	22.05	<30dBm	Pass
06	2437	13.64	13.58	13.47	13.35	13.26	13.19	13.04	12.95	21.83	<30dBm	Pass
11	2462	13.92	--	--	--	--	--	--	--	21.73	<30dBm	Pass

Note: Peak Power Output Value = Reading value on power meter + cable loss

4. Radiated Emission

4.1. Test Equipment

The following test equipments are used during the radiated emission test:

Test Site	Equipment	Manufacturer	Model No./Serial No.	Last Cal.
☒ Site # 3	X Magnetic Loop Antenna	Teseq	HLA6121/ 37133	Sep, 2014
	X Bilog Antenna	Schaffner Chase	CBL6112B/ 2707	Jun, 2015
	X EMI Test Receiver	R&S	ESCS 30/838251/ 001	Jun, 2015
	X Coaxial Cable	QTK(Arnist)	RG 214/ LC003-RG	Jun, 2015
	X Coaxial signal switch	Arnist	MP59B/ 6200798682	Jun, 2015

Test Site	Equipment	Manufacturer	Model No./Serial No.	Last Cal.
☒ CB # 8	X Spectrum Analyzer	R&S	FSP40/ 100339	Oct, 2014
	X Horn Antenna	ETS-Lindgren	3117/ 35205	Mar, 2015
	X Horn Antenna	Schwarzbeck	BBHA9170/209	Jan, 2015
	X Horn Antenna	TRC	AH-0801/95051	Aug, 2014
	X Pre-Amplifier	EMCI	EMC012630SE/980210	Jan, 2015
	X Pre-Amplifier	MITEQ	JS41-001040000-58-5P/153945	Jul, 2015
	X Pre-Amplifier	NARDA	DBL-1840N506/013	Jul, 2015

- Note: 1. All equipments are calibrated with traceable calibrations. Each calibration is traceable to the national or international standards.
2. The test instruments marked with "X" are used to measure the final test results.

4.2. Test Setup

Radiated Emission Below 1GHz

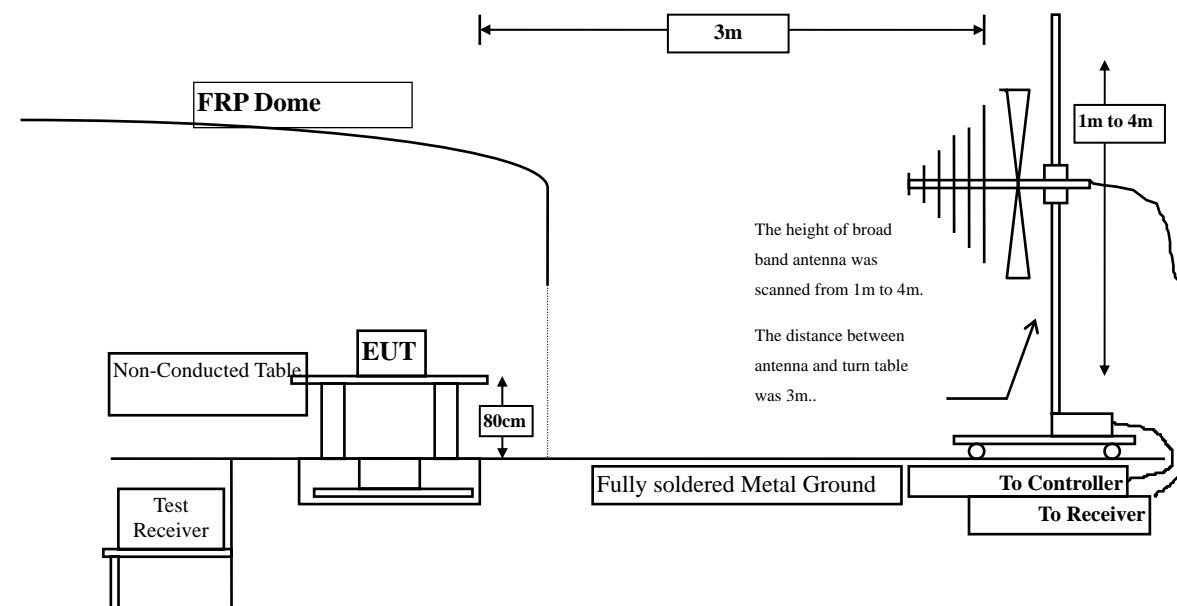

Radiated Emission Above 1GHz

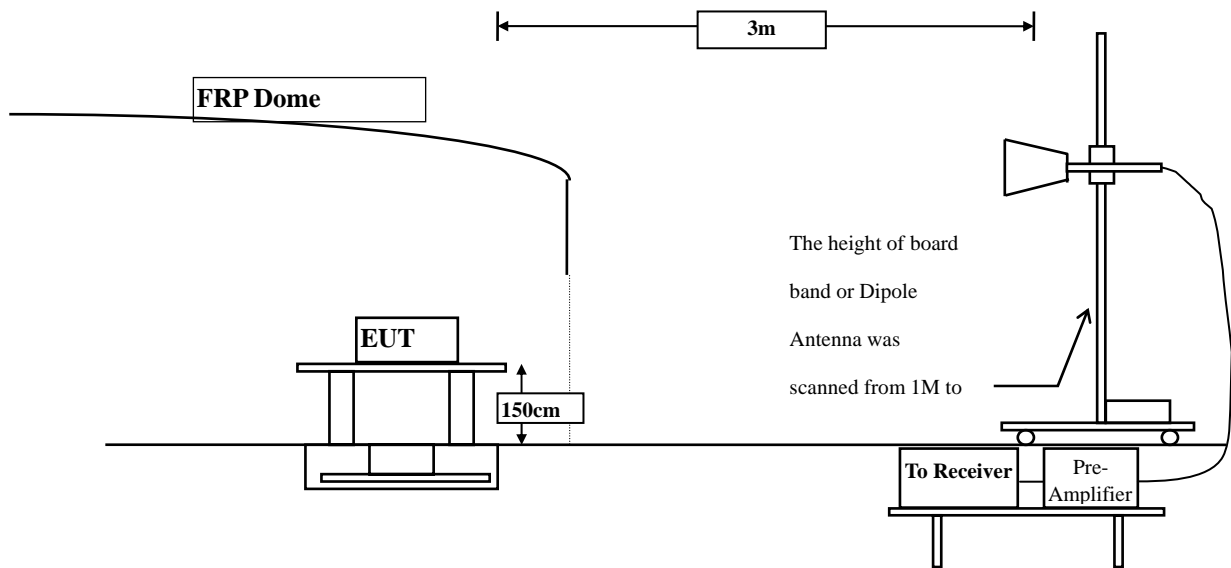

4.3. Limits

Emissions radiated outside of the specified frequency bands, except for harmonics, shall be attenuated by at least 20dB below the level of the fundamental or to the general radiated emission limits in paragraph 15.209, whichever is the lesser attenuation.

FCC Part 15 Subpart C Paragraph 15.209(a) Limits		
Frequency MHz	Field strength (microvolts/meter)	Measurement distance (meter)
0.009-0.490	2400/F(kHz)	300
0.490-1.705	24000/F(kHz)	30
1.705-30	30	30
30-88	100	3
88-216	150	3
216-960	200	3
Above 960	500	3

Remarks: E field strength (dBμV/m) = 20 log E field strength (uV/m)

4.4. Test Procedure

The EUT was setup according to ANSI C63.10: 2013 and tested according to DTS test procedure of KDB558074 for compliance to FCC 47CFR 15.247 requirements.

Measuring the frequency range below 1GHz, the EUT is placed on a turn table which is 0.8 meter above ground, when measuring the frequency range above 1GHz, the EUT is placed on a turn table which is 1.5 meter above ground.

The turn table is rotated 360 degrees to determine the position of the maximum emission level.

The EUT was positioned such that the distance from antenna to the EUT was 3 meters.

The antenna is scanned between 1 meter and 4 meters to find out the maximum emission level. This is repeated for both horizontal and vertical polarization of the antenna. In order to find the maximum emission, all of the interface cables were manipulated according to ANSI C63.10: 2013 on radiated measurement.

The resolution bandwidth below 30MHz setting on the field strength meter is 9kHz and 30MHz~1GHz is 120kHz and above 1GHz is 1MHz.

Radiated emission measurements below 30MHz are made using Loop Antenna and 30MHz~1GHz are made using broadband Bilog antenna and above 1GHz are made using Horn Antennas.

The measurement is divided into the Preliminary Measurement and the Final Measurement.

The suspected frequencies are searched for in Preliminary Measurement with the measurement antenna kept pointed at the source of the emission both in azimuth and elevation, with the polarization of the antenna oriented for maximum response. The antenna is pointed at an angle towards the source of the emission, and the EUT is rotated in both height and polarization to maximize the measured emission. The emission is kept within the illumination area of the 3 dB bandwidth of the antenna.

The worst radiated emission is measured in the Open Area Test Site on the Final Measurement.

The measurement frequency range from 9kHz - 10th Harmonic of fundamental was investigated.

4.5. Uncertainty

± 3.9 dB above 1GHz

± 3.8 dB below 1GHz

4.6. Test Result of Radiated Emission

Product : TABLET PC
 Test Item : Harmonic Radiated Emission Data
 Test Site : No.3 OATS
 Test Mode : Mode 1: Transmit (802.11b 1Mbps) (2412MHz)

Frequency MHz	Correct Factor dB	Reading Level dB μ V	Measurement Level dB μ V/m	Margin dB	Limit dB μ V/m
------------------	-------------------------	--------------------------------	--------------------------------------	--------------	-----------------------

Horizontal

Peak Detector:

4824.000	0.212	38.982	39.195	-34.805	74.000
7236.000	5.860	36.610	42.470	-31.530	74.000
9648.000	11.325	37.207	48.531	-25.469	74.000

Average Detector:

--

Vertical

Peak Detector:

4824.000	11.201	38.113	49.315	-24.685	74.000
7236.000	13.019	36.352	49.371	-24.629	74.000
9648.000	14.887	38.079	52.965	-21.035	74.000

Average Detector:

--

Note:

1. All Readings below 1GHz are Quasi-Peak, above 1GHz are performed with peak and/or average measurements as necessary.
2. Peak measurements: RBW = 1MHz, VBW = 3 MHz, Sweep: Auto.
3. Average measurements: RBW = 1MHz, VBW = 10 Hz, Sweep: Auto.
4. Measurement Level = Reading Level + Correct Factor.
5. Correct Factor = Antenna factor + Cable loss – Amplifier gain.
6. The average measurement was not performed when the peak measured data under the limit of average detection.
7. The emission levels of other frequencies are very lower than the limit and not show in test report.

Product : TABLET PC
 Test Item : Harmonic Radiated Emission Data
 Test Site : No.3 OATS
 Test Mode : Mode 1: Transmit (802.11b 1Mbps) (2437 MHz)

Frequency MHz	Correct Factor dB	Reading Level dB μ V	Measurement Level dB μ V/m	Margin dB	Limit dB μ V/m
Horizontal					
Peak Detector:					
4874.000	0.106	38.996	39.102	-34.898	74.000
7311.000	5.772	36.739	42.512	-31.488	74.000
9748.000	11.810	38.033	49.844	-24.156	74.000
Average Detector:					
--					
Vertical					
Peak Detector:					
4874.000	10.981	39.086	50.066	-23.934	74.000
7311.000	12.962	36.265	49.228	-24.772	74.000
9748.000	14.851	38.013	52.865	-21.135	74.000
Average Detector:					
--					

Note:

1. All Readings below 1GHz are Quasi-Peak, above 1GHz are performed with peak and/or average measurements as necessary.
2. Peak measurements: RBW = 1MHz, VBW = 3 MHz, Sweep: Auto.
3. Average measurements: RBW = 1MHz, VBW = 10 Hz, Sweep: Auto.
4. Measurement Level = Reading Level + Correct Factor.
5. Correct Factor = Antenna factor + Cable loss – Amplifier gain.
6. The average measurement was not performed when the peak measured data under the limit of average detection.
7. The emission levels of other frequencies are very lower than the limit and not show in test report.

Product : TABLET PC
 Test Item : Harmonic Radiated Emission Data
 Test Site : No.3 OATS
 Test Mode : Mode 1: Transmit (802.11b 1Mbps) (2462 MHz)

Frequency MHz	Correct Factor dB	Reading Level dB μ V	Measurement Level dB μ V/m	Margin dB	Limit dB μ V/m
Horizontal					
Peak Detector:					
4924.000	0.266	38.235	38.501	-35.499	74.000
7386.000	6.651	36.148	42.799	-31.201	74.000
9848.000	13.211	36.758	49.970	-24.030	74.000
Average Detector:					
--					
Vertical					
Peak Detector:					
4924.000	11.026	38.592	49.617	-24.383	74.000
7386.000	13.445	36.934	50.379	-23.621	74.000
9848.000	15.731	36.444	52.175	-21.825	74.000

Average Detector:

--

Note:

1. All Readings below 1GHz are Quasi-Peak, above 1GHz are performed with peak and/or average measurements as necessary.
2. Peak measurements: RBW = 1MHz, VBW = 3 MHz, Sweep: Auto.
3. Average measurements: RBW = 1MHz, VBW = 10 Hz, Sweep: Auto.
4. Measurement Level = Reading Level + Correct Factor.
5. Correct Factor = Antenna factor + Cable loss – Amplifier gain.
6. The average measurement was not performed when the peak measured data under the limit of average detection.
7. The emission levels of other frequencies are very lower than the limit and not show in test report.

Product : TABLET PC
 Test Item : Harmonic Radiated Emission Data
 Test Site : No.3 OATS
 Test Mode : Mode 2: Transmit (802.11g 6Mbps) (2412MHz)

Frequency MHz	Correct Factor dB	Reading Level dB μ V	Measurement Level dB μ V/m	Margin dB	Limit dB μ V/m
Horizontal					
Peak Detector:					
4824.000	0.212	38.913	39.126	-34.874	74.000
7236.000	5.860	36.650	42.510	-31.490	74.000
9648.000	11.325	37.337	48.661	-25.339	74.000
Average Detector:					
--					
Vertical					
Peak Detector:					
4824.000	11.201	38.268	49.470	-24.530	74.000
7236.000	13.019	37.015	50.034	-23.966	74.000
9648.000	14.887	38.153	53.039	-20.961	74.000
Average Detector:					
--					

Note:

1. All Readings below 1GHz are Quasi-Peak, above 1GHz are performed with peak and/or average measurements as necessary.
2. Peak measurements: RBW = 1MHz, VBW = 3 MHz, Sweep: Auto.
3. Average measurements: RBW = 1MHz, VBW = 10 Hz, Sweep: Auto.
4. Measurement Level = Reading Level + Correct Factor.
5. Correct Factor = Antenna factor + Cable loss – Amplifier gain.
6. The average measurement was not performed when the peak measured data under the limit of average detection.
7. The emission levels of other frequencies are very lower than the limit and not show in test report.

Product : TABLET PC
 Test Item : Harmonic Radiated Emission Data
 Test Site : No.3 OATS
 Test Mode : Mode 2: Transmit (802.11g 6Mbps) (2437 MHz)

Frequency MHz	Correct Factor dB	Reading Level dB μ V	Measurement Level dB μ V/m	Margin dB	Limit dB μ V/m
------------------	-------------------------	--------------------------------	--------------------------------------	--------------	-----------------------

Horizontal

Peak Detector:

4874.000	0.106	38.254	38.360	-35.640	74.000
7311.000	5.772	36.068	41.841	-32.159	74.000
9748.000	11.810	37.635	49.446	-24.554	74.000

Average Detector:

--

Peak Detector:

4874.000	10.981	38.816	49.796	-24.204	74.000
7311.000	12.962	36.126	49.089	-24.911	74.000
9748.000	14.851	37.190	52.042	-21.958	74.000

Average Detector:

--

Note:

1. All Readings below 1GHz are Quasi-Peak, above 1GHz are performed with peak and/or average measurements as necessary.
2. Peak measurements: RBW = 1MHz, VBW = 3 MHz, Sweep: Auto.
3. Average measurements: RBW = 1MHz, VBW = 10 Hz, Sweep: Auto.
4. Measurement Level = Reading Level + Correct Factor.
5. Correct Factor = Antenna factor + Cable loss – Amplifier gain.
6. The average measurement was not performed when the peak measured data under the limit of average detection.
7. The emission levels of other frequencies are very lower than the limit and not show in test report.

Product : TABLET PC
 Test Item : Harmonic Radiated Emission Data
 Test Site : No.3 OATS
 Test Mode : Mode 2: Transmit (802.11g 6Mbps) (2462 MHz)

Frequency MHz	Correct Factor dB	Reading Level dB μ V	Measurement Level dB μ V/m	Margin dB	Limit dB μ V/m
Horizontal					
Peak Detector:					
4924.000	0.266	39.011	39.277	-34.723	74.000
7386.000	6.651	36.715	43.366	-30.634	74.000
9848.000	13.211	37.107	50.319	-23.681	74.000
Average Detector:					
--					
Vertical					
Peak Detector:					
4924.000	11.026	38.521	49.546	-24.454	74.000
7386.000	13.445	36.343	49.788	-24.212	74.000
9848.000	15.731	37.256	52.987	-21.013	74.000

Average Detector:
--

Note:

1. All Readings below 1GHz are Quasi-Peak, above 1GHz are performed with peak and/or average measurements as necessary.
2. Peak measurements: RBW = 1MHz, VBW = 3 MHz, Sweep: Auto.
3. Average measurements: RBW = 1MHz, VBW = 10 Hz, Sweep: Auto.
4. Measurement Level = Reading Level + Correct Factor.
5. Correct Factor = Antenna factor + Cable loss – Amplifier gain.
6. The average measurement was not performed when the peak measured data under the limit of average detection.
7. The emission levels of other frequencies are very lower than the limit and not show in test report.

Product : TABLET PC
 Test Item : Harmonic Radiated Emission Data
 Test Site : No.3 OATS
 Test Mode : Mode 3: Transmit (802.11n MCS0 7.2Mbps 20M-BW)(2412MHz)

Frequency MHz	Correct Factor dB	Reading Level dB μ V	Measurement Level dB μ V/m	Margin dB	Limit dB μ V/m
Horizontal					
Peak Detector:					
4824.000	0.212	38.878	39.091	-34.909	74.000
7236.000	5.860	36.960	42.820	-31.180	74.000
9648.000	11.325	37.329	48.653	-25.347	74.000
Average Detector:					
--					
Vertical					
Peak Detector:					
4824.000	11.201	39.104	50.306	-23.694	74.000
7236.000	13.019	36.251	49.270	-24.730	74.000
9648.000	14.887	37.512	52.398	-21.602	74.000
Average Detector:					
--					

Note:

1. All Readings below 1GHz are Quasi-Peak, above 1GHz are performed with peak and/or average measurements as necessary.
2. Peak measurements: RBW = 1MHz, VBW = 3 MHz, Sweep: Auto.
3. Average measurements: RBW = 1MHz, VBW = 10 Hz, Sweep: Auto.
4. Measurement Level = Reading Level + Correct Factor.
5. Correct Factor = Antenna factor + Cable loss – Amplifier gain.
6. The average measurement was not performed when the peak measured data under the limit of average detection.
7. The emission levels of other frequencies are very lower than the limit and not show in test report.

Product : TABLET PC
 Test Item : Harmonic Radiated Emission Data
 Test Site : No.3 OATS
 Test Mode : Mode 3: Transmit (802.11n MCS0 7.2Mbps 20M-BW) (2437 MHz)

Frequency MHz	Correct Factor dB	Reading Level dB μ V	Measurement Level dB μ V/m	Margin dB	Limit dB μ V/m
Horizontal					
Peak Detector:					
4874.000	0.106	38.038	38.144	-35.856	74.000
7311.000	5.772	35.995	41.768	-32.232	74.000
9748.000	11.810	37.429	49.240	-24.760	74.000
Average Detector:					
--					
Vertical					
Peak Detector:					
4874.000	10.981	38.712	49.692	-24.308	74.000
7311.000	12.962	37.218	50.181	-23.819	74.000
9748.000	14.851	37.174	52.026	-21.974	74.000

Average Detector:
--

Note:

1. All Readings below 1GHz are Quasi-Peak, above 1GHz are performed with peak and/or average measurements as necessary.
2. Peak measurements: RBW = 1MHz, VBW = 3 MHz, Sweep: Auto.
3. Average measurements: RBW = 1MHz, VBW = 10 Hz, Sweep: Auto.
4. Measurement Level = Reading Level + Correct Factor.
5. Correct Factor = Antenna factor + Cable loss – Amplifier gain.
6. The average measurement was not performed when the peak measured data under the limit of average detection.
7. The emission levels of other frequencies are very lower than the limit and not show in test report.

Product : TABLET PC
 Test Item : Harmonic Radiated Emission Data
 Test Site : No.3 OATS
 Test Mode : Mode 3: Transmit (802.11n MCS0 7.2Mbps 20M-BW) (2462 MHz)

Frequency MHz	Correct Factor dB	Reading Level dB μ V	Measurement Level dB μ V/m	Margin dB	Limit dB μ V/m
Horizontal					
Peak Detector:					
4924.000	0.266	38.858	39.124	-34.876	74.000
7386.000	6.651	36.632	43.283	-30.717	74.000
9848.000	13.211	37.852	51.064	-22.936	74.000
Average Detector:					
--					
Vertical					
Peak Detector:					
4924.000	11.026	38.468	49.493	-24.507	74.000
7386.000	13.445	36.529	49.974	-24.026	74.000
9848.000	15.731	38.017	53.748	-20.252	74.000

Average Detector:
--

Note:

1. All Readings below 1GHz are Quasi-Peak, above 1GHz are performed with peak and/or average measurements as necessary.
2. Peak measurements: RBW = 1MHz, VBW = 3 MHz, Sweep: Auto.
3. Average measurements: RBW = 1MHz, VBW = 10 Hz, Sweep: Auto.
4. Measurement Level = Reading Level + Correct Factor.
5. Correct Factor = Antenna factor + Cable loss – Amplifier gain.
6. The average measurement was not performed when the peak measured data under the limit of average detection.
7. The emission levels of other frequencies are very lower than the limit and not show in test report.

Product : TABLET PC
 Test Item : General Radiated Emission Data
 Test Site : No.3 OATS
 Test Mode : Mode 1: Transmit (802.11b 1Mbps)(2437 MHz)

Frequency MHz	Correct Factor dB	Reading Level dB μ V	Measurement Level dB μ V/m	Margin dB	Limit dB μ V/m
Horizontal					
263.362	-5.004	30.249	25.244	-20.756	46.000
347.710	-2.250	30.177	27.927	-18.073	46.000
517.812	1.685	30.858	32.543	-13.457	46.000
575.449	2.962	38.395	41.357	-4.643	46.000
791.942	5.212	27.755	32.967	-13.033	46.000
933.928	6.630	25.748	32.379	-13.621	46.000
Vertical					
263.362	-7.569	30.225	22.655	-23.345	46.000
375.826	-1.955	27.919	25.964	-20.036	46.000
503.754	-0.852	35.435	34.583	-11.417	46.000
575.449	-5.622	39.053	33.431	-12.569	46.000
755.391	3.286	27.513	30.799	-15.201	46.000
964.855	7.897	24.232	32.130	-21.870	54.000

Note:

1. All Readings below 1GHz are Quasi-Peak, above 1GHz are performed with peak and/or average measurements as necessary.
2. Peak measurements: RBW = 1MHz, VBW = 3 MHz, Sweep: Auto.
3. Average measurements: RBW = 1MHz, VBW = 10 Hz, Sweep: Auto.
4. Measurement Level = Reading Level + Correct Factor.
5. Correct Factor = Antenna factor + Cable loss – Amplifier gain.
6. The average measurement was not performed when the peak measured data under the limit of average detection.
7. The emission levels of other frequencies are very lower than the limit and not show in test report.
8. No emission found between lowest internal used/generated frequency to 30MHz.

Product : TABLET PC
 Test Item : General Radiated Emission Data
 Test Site : No.3 OATS
 Test Mode : Mode 2: Transmit (802.11g 6Mbps)(2437 MHz)

Frequency MHz	Correct Factor dB	Reading Level dB μ V	Measurement Level dB μ V/m	Margin dB	Limit dB μ V/m
Horizontal					
249.304	-6.004	36.341	30.337	-15.663	46.000
316.783	-4.235	40.715	36.480	-9.520	46.000
409.565	-3.102	35.006	31.905	-14.095	46.000
575.449	2.962	38.320	41.282	-4.718	46.000
791.942	5.212	28.951	34.163	-11.837	46.000
933.928	6.630	25.475	32.106	-13.894	46.000
Vertical					
105.913	-0.261	24.864	24.603	-18.897	43.500
378.638	-1.584	27.218	25.634	-20.366	46.000
503.754	-0.852	35.335	34.483	-11.517	46.000
575.449	-5.622	39.123	33.501	-12.499	46.000
759.609	2.506	29.370	31.876	-14.124	46.000
933.928	5.813	26.386	32.199	-13.801	46.000

Note:

1. All Readings below 1GHz are Quasi-Peak, above 1GHz are performed with peak and/or average measurements as necessary.
2. Peak measurements: RBW = 1MHz, VBW = 3 MHz, Sweep: Auto.
3. Average measurements: RBW = 1MHz, VBW = 10 Hz, Sweep: Auto.
4. Measurement Level = Reading Level + Correct Factor.
5. Correct Factor = Antenna factor + Cable loss – Amplifier gain.
6. The average measurement was not performed when the peak measured data under the limit of average detection.
7. The emission levels of other frequencies are very lower than the limit and not show in test report.
8. No emission found between lowest internal used/generated frequency to 30MHz.

Product : TABLET PC
 Test Item : General Radiated Emission Data
 Test Site : No.3 OATS
 Test Mode : Mode 3: Transmit (802.11n MCS0 7.2Mbps 20M-BW)(2437 MHz)

Frequency MHz	Correct Factor dB	Reading Level dB μ V	Measurement Level dB μ V/m	Margin dB	Limit dB μ V/m
Horizontal					
263.362	-5.004	30.545	25.540	-20.460	46.000
373.014	-1.153	31.158	30.005	-15.995	46.000
517.812	1.685	31.547	33.232	-12.768	46.000
575.449	2.962	37.137	40.099	-5.901	46.000
791.942	5.212	29.039	34.251	-11.749	46.000
960.638	6.391	26.317	32.708	-21.292	54.000
Vertical					
263.362	-7.569	29.724	22.154	-23.846	46.000
378.638	-1.584	27.615	26.031	-19.969	46.000
503.754	-0.852	35.215	34.363	-11.637	46.000
575.449	-5.622	39.631	34.009	-11.991	46.000
756.797	3.066	28.169	31.235	-14.765	46.000
964.855	7.897	25.404	33.302	-20.698	54.000

Note:

1. All Readings below 1GHz are Quasi-Peak, above 1GHz are performed with peak and/or average measurements as necessary.
2. Peak measurements: RBW = 1MHz, VBW = 3 MHz, Sweep: Auto.
3. Average measurements: RBW = 1MHz, VBW = 10 Hz, Sweep: Auto.
4. Measurement Level = Reading Level + Correct Factor.
5. Correct Factor = Antenna factor + Cable loss – Amplifier gain.
6. The average measurement was not performed when the peak measured data under the limit of average detection.
7. The emission levels of other frequencies are very lower than the limit and not show in test report.
8. No emission found between lowest internal used/generated frequency to 30MHz.

5. RF antenna conducted test

5.1. Test Equipment

	Equipment	Manufacturer	Model No./Serial No.	Last Cal.
	Spectrum Analyzer	R&S	FSP40 / 100170	Jun, 2015
	Spectrum Analyzer	Agilent	E4407B / US39440758	Jun, 2015
X	Spectrum Analyzer	Agilent	N9010A / MY48030495	Apr., 2015

- Note:
1. All equipments are calibrated with traceable calibrations. Each calibration is traceable to the national or international standards.
 2. The test instruments marked with “X” are used to measure the final test results.

5.2. Test Setup

RF antenna Conducted Measurement:

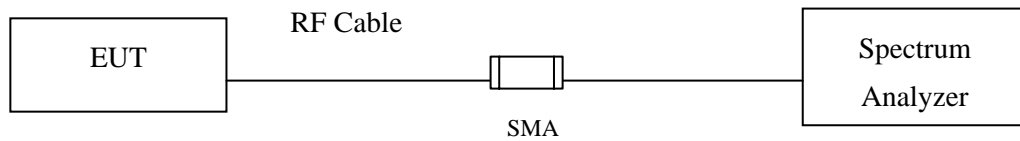

5.3. Limits

In any 100 kHz bandwidth outside the frequency band in which the spread spectrum intentional radiator is operating, the radio frequency power that is produced by the intentional radiator shall be at least 20 dB below that in the 100 kHz bandwidth within the band that contains the highest level of the desired power, based on either an RF conducted or a radiated measurement. Attenuation below the general limits specified in Section 15.209(a) is not required. In addition, radiated emissions which fall in the restricted bands, as defined in Section 15.205(a), must also comply with the radiated emission limits specified in Section 15.209(a) (see Section 15.205(c)).

5.4. Test Procedure

The EUT was tested according to DTS test procedure of KDB558074 for compliance to FCC 47CFR 15.247 requirements.

Set RBW = 100 kHz, Set VBW > RBW, scan up through 10th harmonic.

5.5. Uncertainty

The measurement uncertainty

Conducted is defined as $\pm 1.27\text{dB}$

5.6. Test Result of RF antenna conducted test

Product : TABLET PC
Test Item : RF antenna conducted test
Test Site : No.3 OATS
Test Mode : Mode 1: Transmit (802.11b 1Mbps)

Channel 01 (2412MHz)

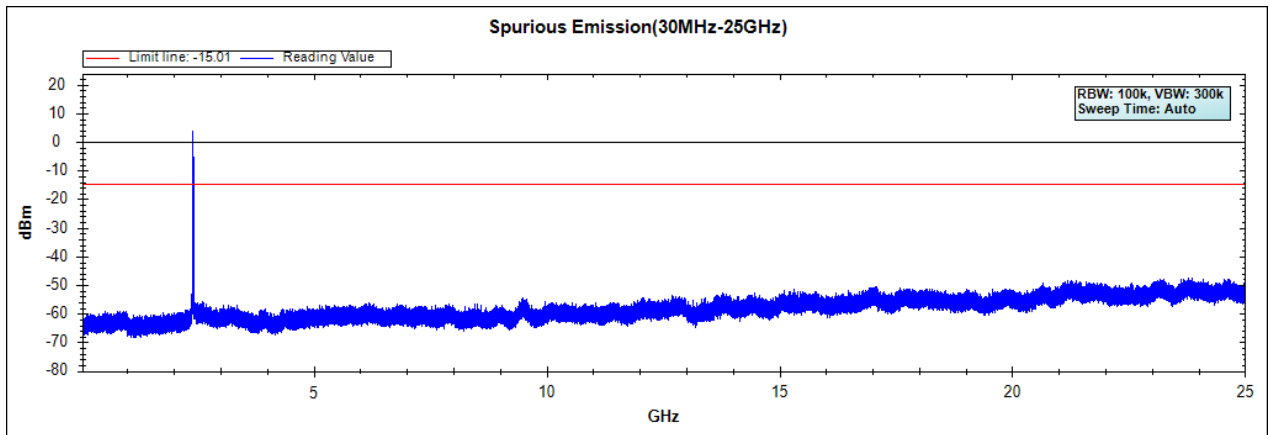

Channel 06 (2437MHz)

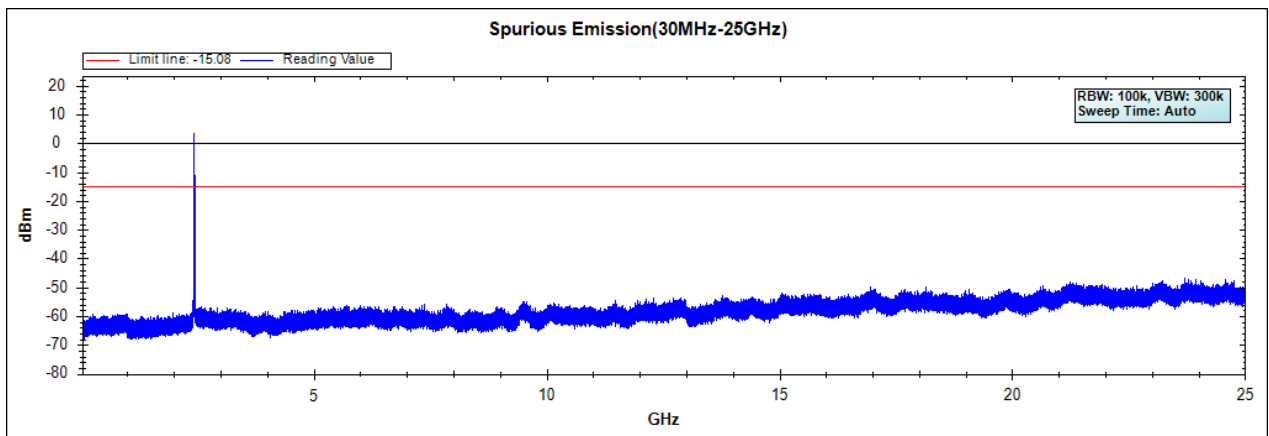

Channel 11 (2462MHz)

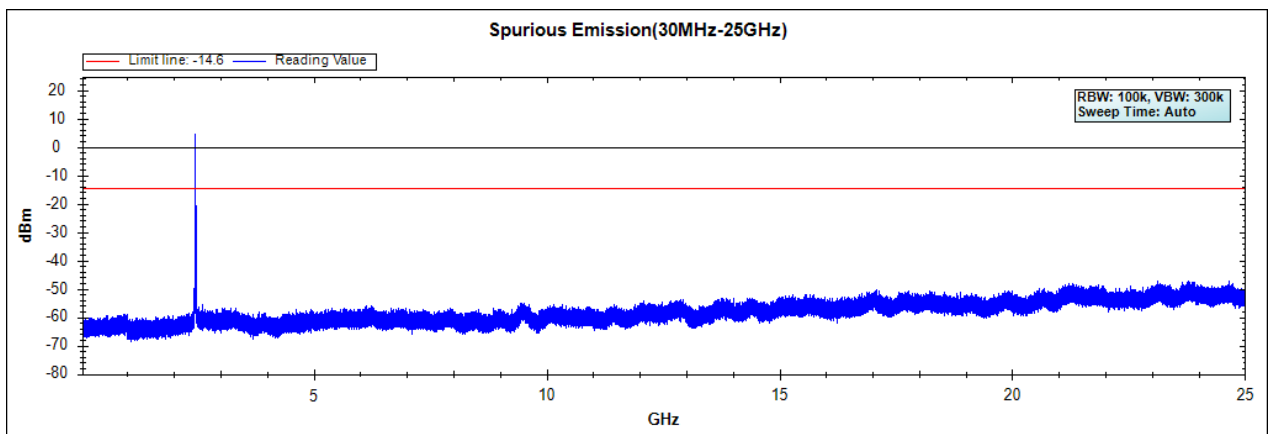

Note: The above test pattern is synthesized by multiple of the frequency range.

Product : TABLET PC
Test Item : RF Antenna Conducted Spurious
Test Site : No.3 OATS
Test Mode : Mode 2: Transmit (802.11g 6Mbps)

Channel 01 (2412MHz)

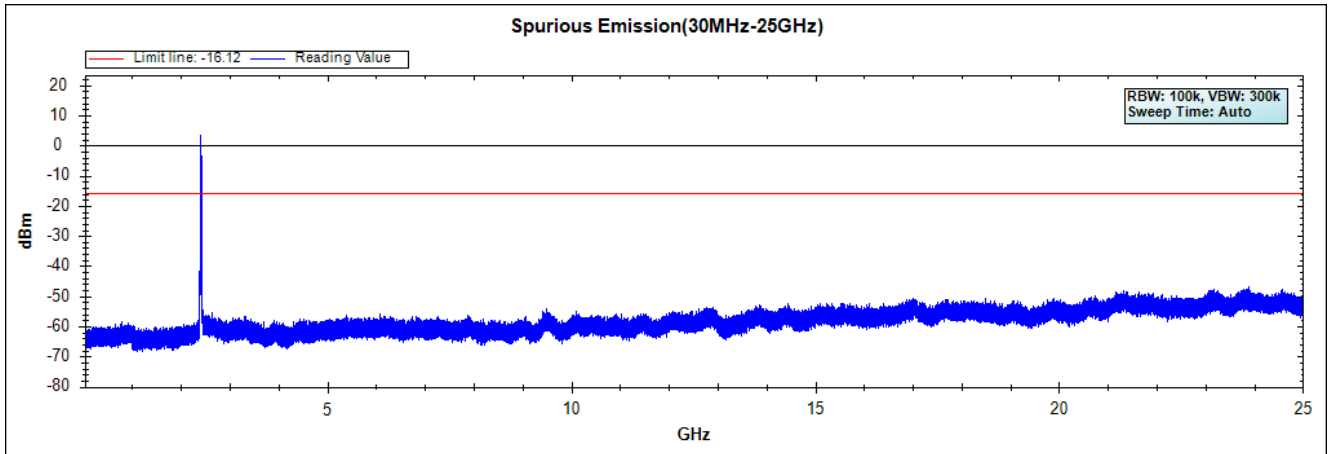

Channel 06 (2437MHz)

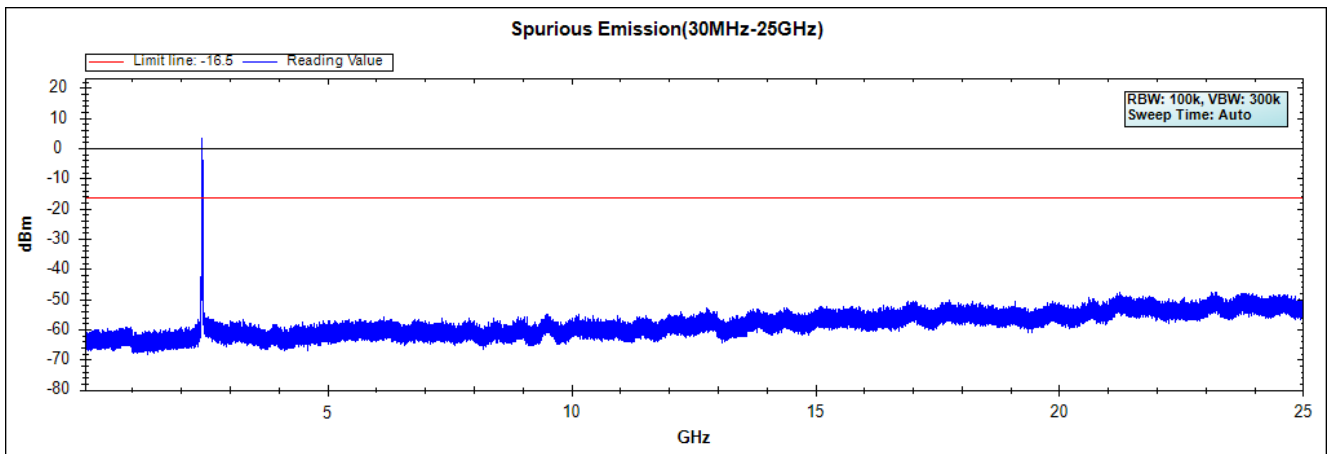

Channel 11 (2462MHz)

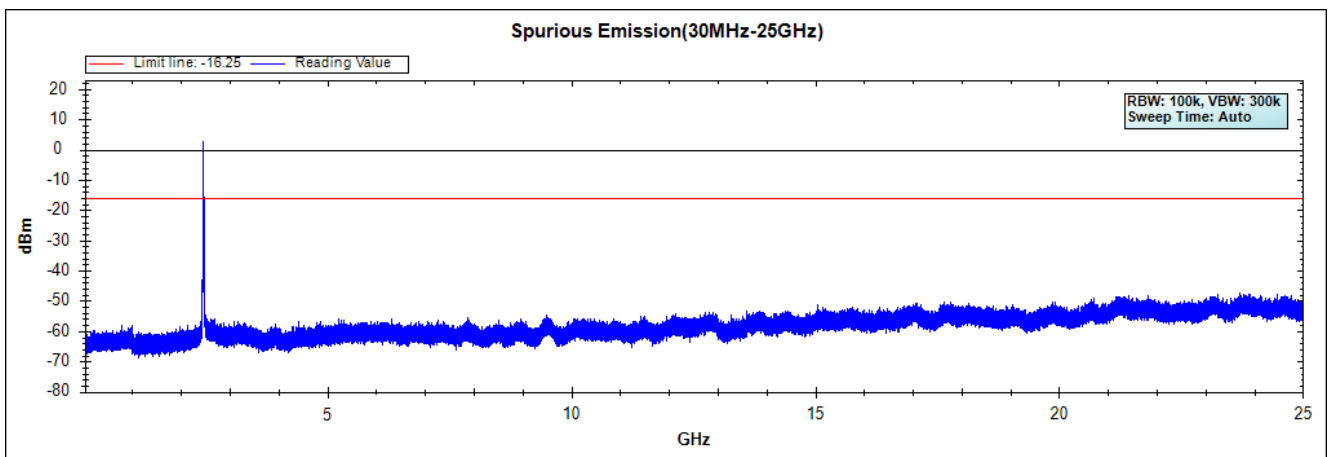

Note: The above test pattern is synthesized by multiple of the frequency range.

Product : TABLET PC
Test Item : RF Antenna Conducted Spurious
Test Site : No.3 OATS
Test Mode : Mode 3: Transmit (802.11n MCS0 7.2Mbps 20M-BW)

Channel 01 (2412MHz)

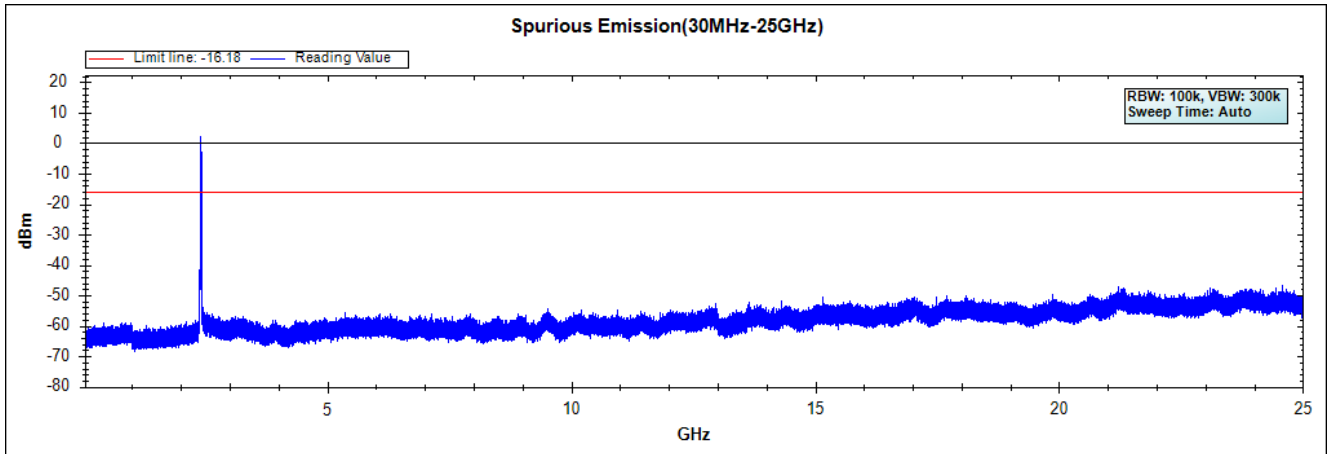

Channel 06 (2437MHz)

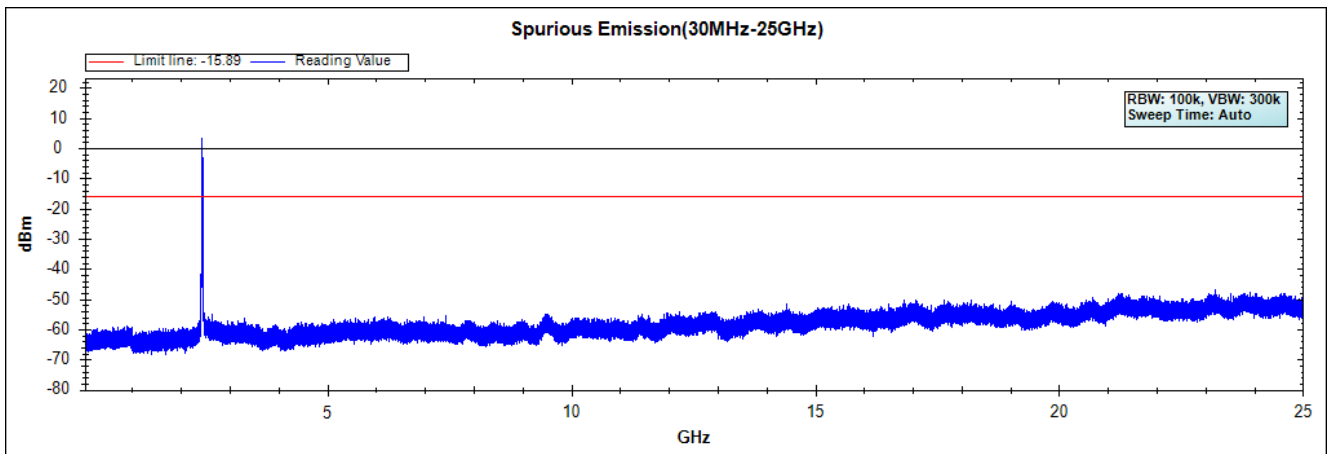

Channel 11 (2462MHz)

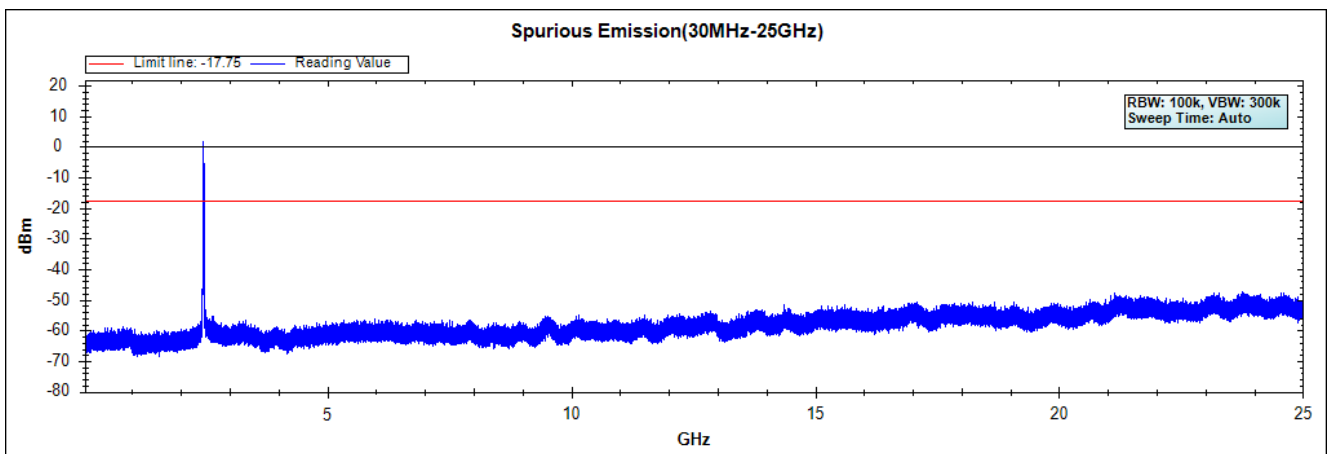

Note: The above test pattern is synthesized by multiple of the frequency range.

6. Band Edge

6.1. Test Equipment

RF Radiated Measurement:

The following test equipments are used during the band edge tests:

Test Site	Equipment	Manufacturer	Model No./Serial No.	Last Cal.
☒ CB # 8	X Spectrum Analyzer	R&S	FSP40/ 100339	Oct, 2014
	X Horn Antenna	ETS-Lindgren	3117/ 35205	Mar, 2015
	X Horn Antenna	Schwarzbeck	BBHA9170/209	Jan, 2015
	X Horn Antenna	TRC	AH-0801/95051	Aug, 2014
	X Pre-Amplifier	EMCI	EMC012630SE/980210	Jan, 2015
	X Pre-Amplifier	MITEQ	JS41-001040000-58-5P/153945	Jul, 2015
	X Pre-Amplifier	NARDA	DBL-1840N506/013	Jul, 2015

- Note:
1. All instruments are calibrated every one year.
 2. The test instruments marked by “X” are used to measure the final test results.

6.2. Test Setup

RF Radiated Measurement:

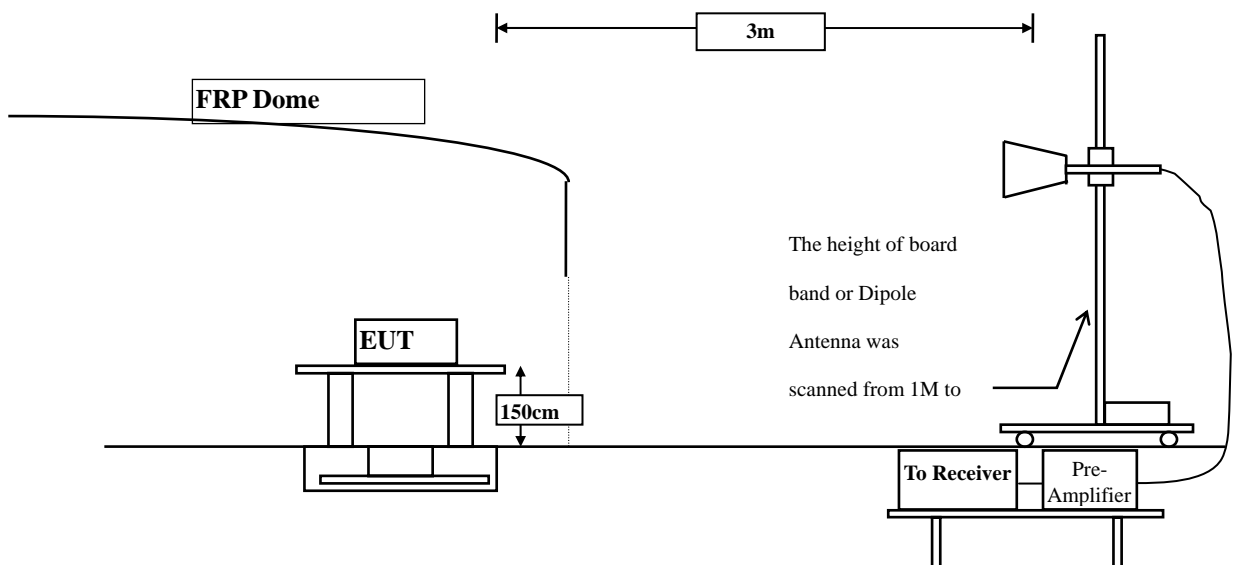

6.3. Limits

Emissions radiated outside of the specified frequency bands, except for harmonics, shall be attenuated by at least 20dB below the level of the fundamental or to the general radiated emission limits in paragraph 15.209, whichever is the lesser attenuation.

6.4. Test Procedure

The EUT was setup according to ANSI C63.10, 2013 and tested according to DTS test procedure of KDB558074 for compliance to FCC 47CFR 15.247 requirements.

The EUT is placed on a turn table which is 1.5 meter above ground. The turn table is rotated 360 degrees to determine the position of the maximum emission level. The EUT was positioned such that the distance from antenna to the EUT was 3 meters.

The antenna is scanned from 1 meter to 4 meters to find out the maximum emission level. This is repeated for both horizontal and vertical polarization of the antenna. In order to find the maximum emission, all of the interface cables were manipulated according to ANSI C63.10:2013 on radiated measurement.

6.5. Uncertainty

± 3.9 dB above 1GHz

± 3.8 dB below 1GHz

6.6. Test Result of Band Edge

Product : TABLET PC
 Test Item : Band Edge Data
 Test Site : No.3 OATS
 Test Mode : Mode 1: Transmit (802.11b 1Mbps)

RF Radiated Measurement (Horizontal):

Channel No.	Frequency (MHz)	Correct Factor (dB)	Reading Level (dBuV)	Emission Level (dBuV/m)	Peak Limit (dBuV/m)	Average Limit (dBuV/m)	Result
01 (Peak)	2387.200	-6.230	51.024	44.794	74.00	54.00	Pass
01 (Peak)	2390.000	-6.204	48.191	41.987	74.00	54.00	Pass
01 (Peak)	2398.300	-6.136	58.802	52.666	74.00	54.00	Pass
01 (Peak)	2400.000	-6.124	55.875	49.750	--	--	--
01 (Peak)	2413.000	-6.127	104.383	98.257	--	--	--
01 (Average)	2388.000	-6.223	40.608	34.385	74.00	54.00	Pass
01 (Average)	2390.000	-6.204	37.582	31.378	74.00	54.00	Pass
01 (Average)	2398.000	-6.139	52.420	46.282	74.00	54.00	Pass
01 (Average)	2400.000	-6.124	46.699	40.574	--	--	--
01 (Average)	2411.200	-6.125	101.497	95.372	--	--	--

Figure Channel 01: Horizontal (Peak)

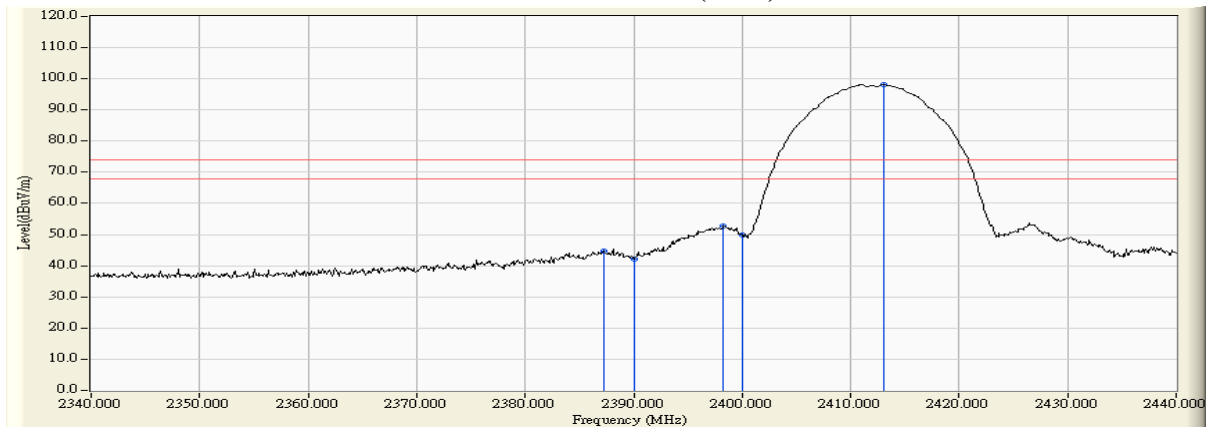
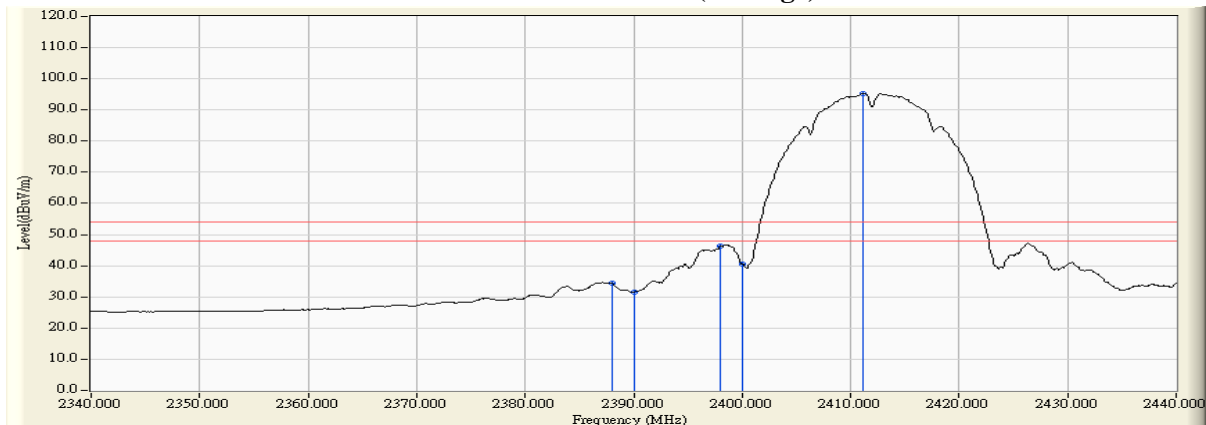

Figure Channel 01: Horizontal (Average)



- Note: 1. All readings above 1GHz are performed with peak and/or average measurements as necessary.
 2. Peak measurements: RBW = 1MHz, VBW = 3 MHz, Sweep: Auto.
 3. Average measurements: RBW = 1MHz, VBW = 10 Hz, Sweep: Auto.
 4. “ * ”, means this data is the worst emission level.
 5. Measurement Level = Reading Level + Correct Factor.
 6. The average measurement was not performed when the peak measured data under the limit of average detection.

Product : TABLET PC
 Test Item : Band Edge Data
 Test Site : No.3 OATS
 Test Mode : Mode 1: Transmit (802.11b 1Mbps)

RF Radiated Measurement (Vertical):

Channel No.	Frequency (MHz)	Correct Factor (dB)	Reading Level (dBuV)	Emission Level (dBuV/m)	Peak Limit (dBuV/m)	Average Limit (dBuV/m)	Result
01 (Peak)	2387.300	4.402	54.387	58.789	74.00	54.00	Pass
01 (Peak)	2390.000	4.426	53.958	58.384	74.00	54.00	Pass
01 (Peak)	2396.900	4.478	61.648	66.126	74.00	54.00	Pass
01 (Peak)	2400.000	4.497	58.315	62.812	--	--	--
01 (Peak)	2413.000	4.485	106.472	110.957	--	--	--
01 (Average)	2386.200	4.393	44.405	48.798	74.00	54.00	Pass
01 (Average)	2390.000	4.426	42.078	46.504	74.00	54.00	Pass
01 (Average)	2396.600	4.477	55.284	59.760	74.00	54.00	Pass
01 (Average)	2400.000	4.497	49.618	54.115	--	--	--
01 (Average)	2411.200	4.488	103.595	108.083	--	--	--

Figure Channel 01: Vertical (Peak)

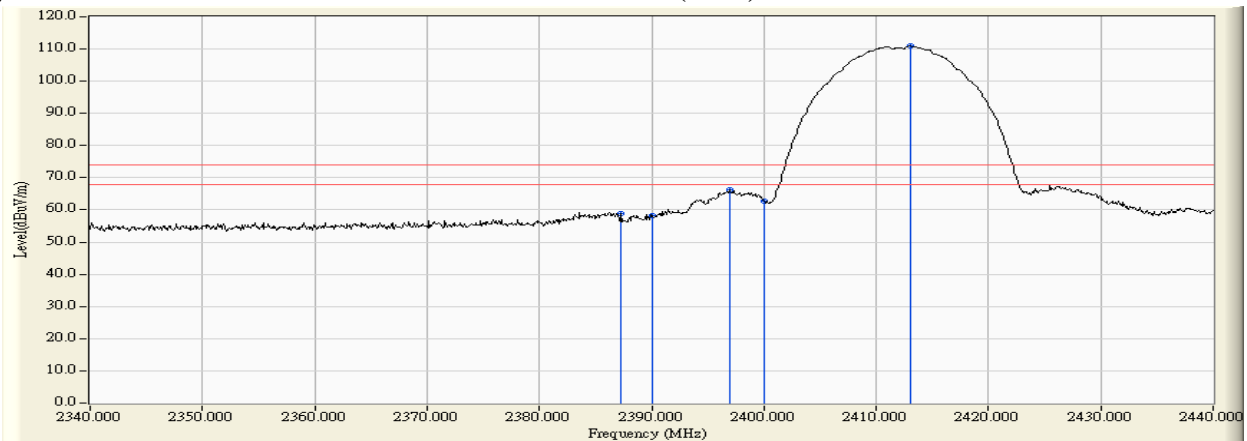
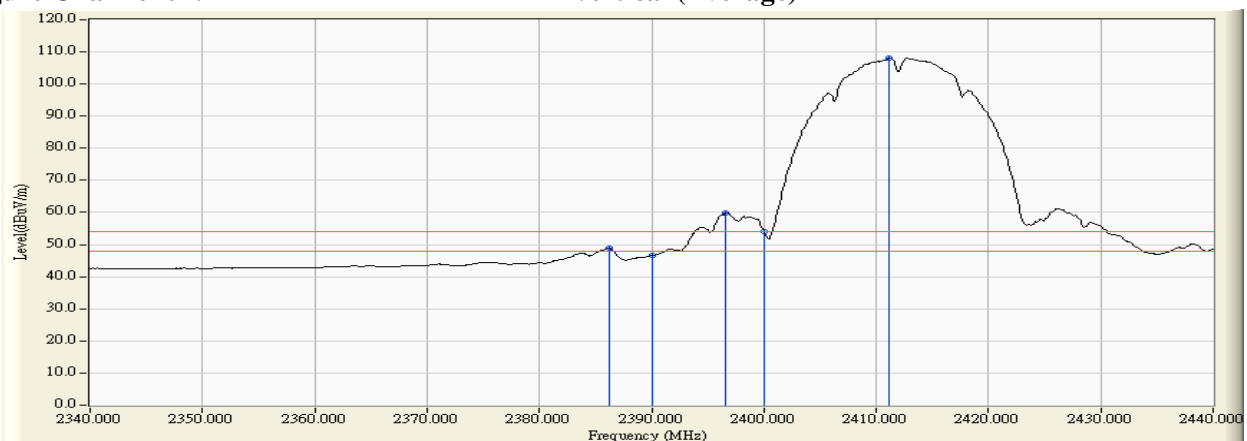

Figure Channel 01: Vertical (Average)



- Note: 1. All readings above 1GHz are performed with peak and/or average measurements as necessary.
 2. Peak measurements: RBW = 1MHz, VBW = 3 MHz, Sweep: Auto.
 3. Average measurements: RBW = 1MHz, VBW = 10 Hz, Sweep: Auto.
 4. “ * ”, means this data is the worst emission level.
 5. Measurement Level = Reading Level + Correct Factor.
 6. The average measurement was not performed when the peak measured data under the limit of average detection.

Product : TABLET PC
 Test Item : Band Edge Data
 Test Site : No.3 OATS
 Test Mode : Mode 1: Transmit (802.11b 1Mbps)

RF Radiated Measurement (Horizontal):

Channel No.	Frequency (MHz)	Correct Factor (dB)	Reading Level (dBuV)	Emission Level (dBuV/m)	Peak Limit (dBuV/m)	Average Limit (dBuV/m)	Result
11 (Peak)	2463.000	-6.159	104.087	97.929	--	--	--
11 (Peak)	2483.500	-6.296	50.991	44.695	74.00	54.00	Pass
11 (Peak)	2488.200	-6.307	53.000	46.692	74.00	54.00	Pass
11 (Average)	2461.200	-6.140	101.212	95.072	--	--	--
11 (Average)	2483.500	-6.296	40.159	33.863	74.00	54.00	Pass
11 (Average)	2488.300	-6.308	41.157	34.849	74.00	54.00	Pass

Figure Channel 11: Horizontal (Peak)

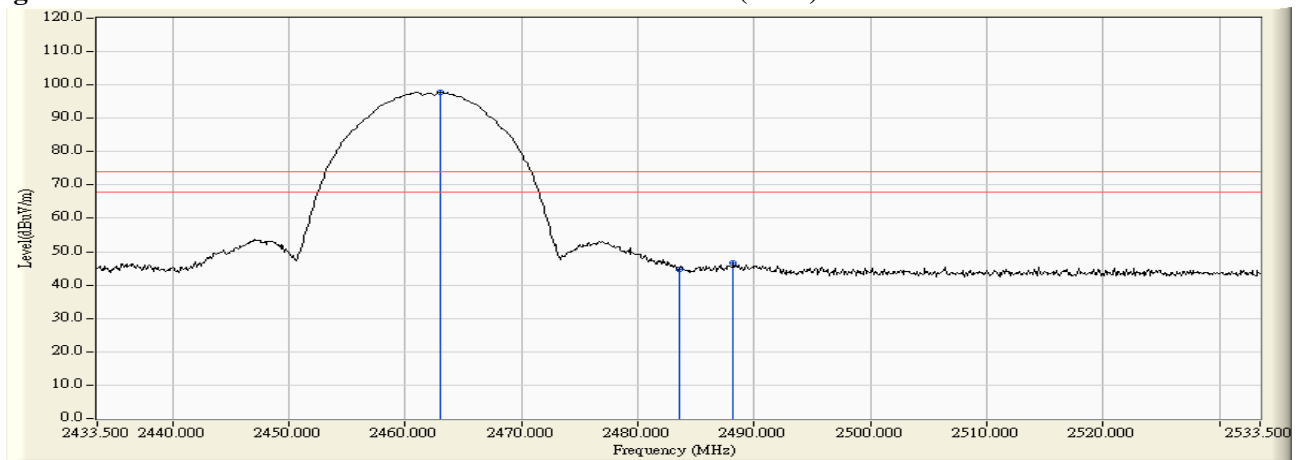
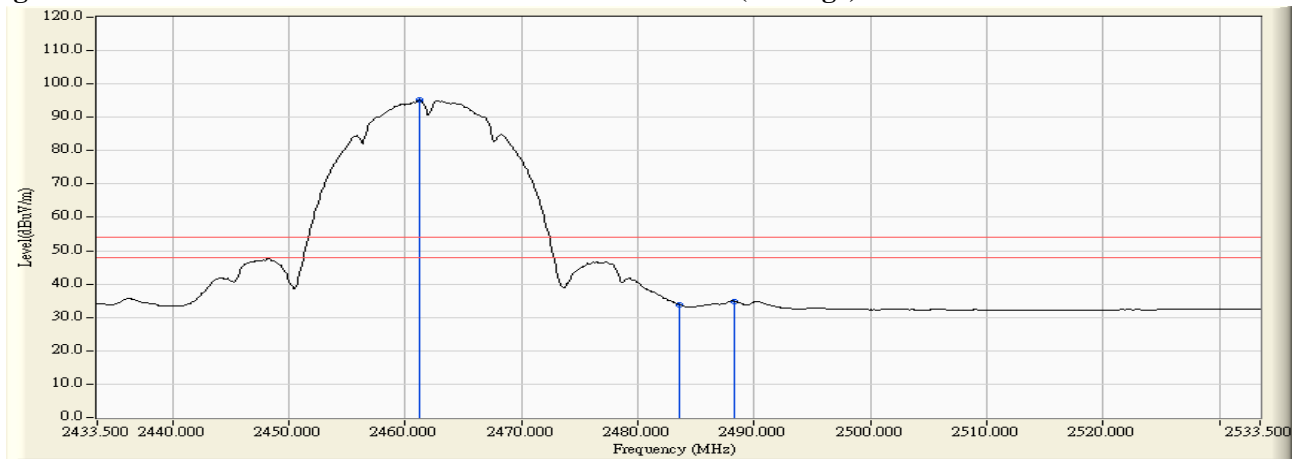

Figure Channel 11: Horizontal (Average)



Note:

1. All readings above 1GHz are performed with peak and/or average measurements as necessary.
2. Peak measurements: RBW = 1MHz, VBW = 3 MHz, Sweep: Auto.
3. Average measurements: RBW = 1MHz, VBW = 10 Hz, Sweep: Auto.
4. “ * ”, means this data is the worst emission level.
5. Measurement Level = Reading Level + Correct Factor.
6. The average measurement was not performed when the peak measured data under the limit of average detection.

Product : TABLET PC
 Test Item : Band Edge Data
 Test Site : No.3 OATS
 Test Mode : Mode 1: Transmit (802.11b 1Mbps)

RF Radiated Measurement (Vertical):

Channel No.	Frequency (MHz)	Correct Factor (dB)	Reading Level (dBuV)	Emission Level (dBuV/m)	Peak Limit (dBuV/m)	Average Limit (dBuV/m)	Result
11 (Peak)	2463.000	4.412	105.464	109.877	--	--	--
11 (Peak)	2483.500	4.260	52.351	56.611	74.00	54.00	Pass
11 (Peak)	2488.300	4.243	53.967	58.211	74.00	54.00	Pass
11 (Average)	2461.200	4.433	102.567	106.999	--	--	--
11 (Average)	2483.500	4.260	41.103	45.363	74.00	54.00	Pass
11 (Average)	2488.300	4.243	42.508	46.752	74.00	54.00	Pass

Figure Channel 11: Vertical (Peak)

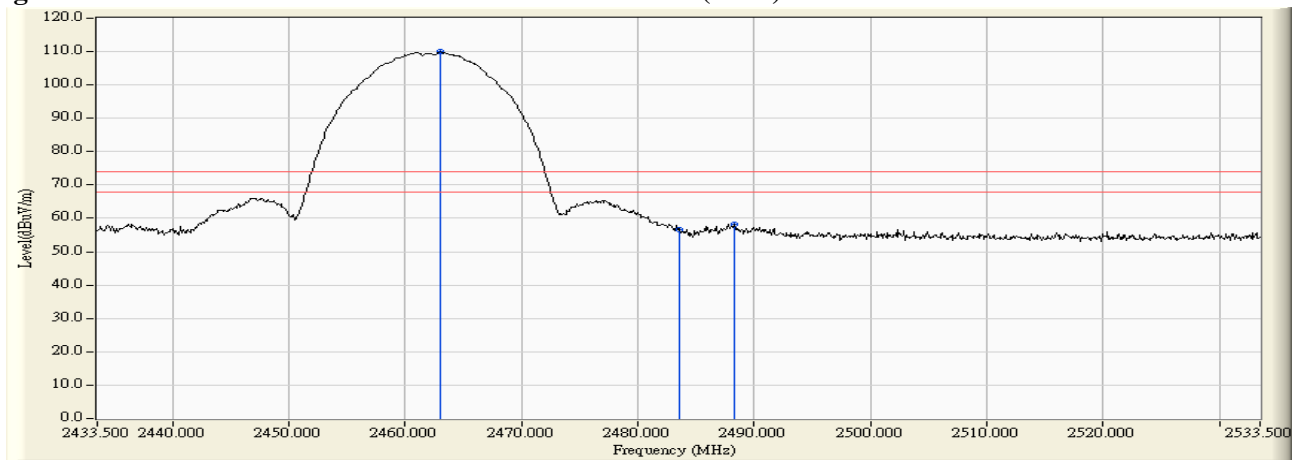
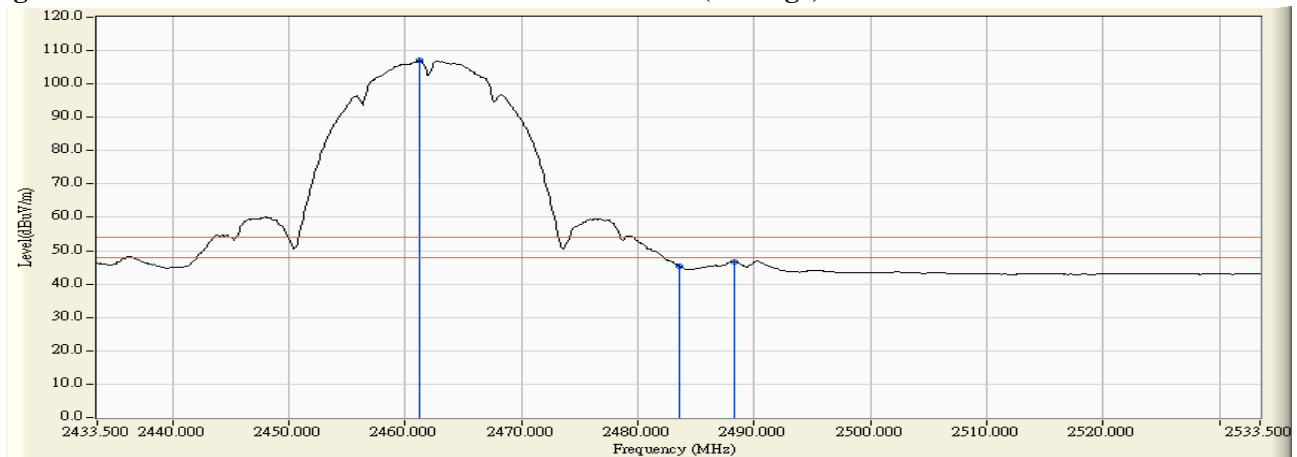

Figure Channel 11: Vertical (Average)



Note:

1. All readings above 1GHz are performed with peak and/or average measurements as necessary.
2. Peak measurements: RBW = 1MHz, VBW = 3 MHz, Sweep: Auto.
3. Average measurements: RBW = 1MHz, VBW = 10 Hz, Sweep: Auto.
4. “ * ”, means this data is the worst emission level.
5. Measurement Level = Reading Level + Correct Factor.
6. The average measurement was not performed when the peak measured data under the limit of average detection.

Product : TABLET PC
 Test Item : Band Edge Data
 Test Site : No.3 OATS
 Test Mode : Mode 2: Transmit (802.11g 6Mbps)

RF Radiated Measurement (Horizontal):

Channel No.	Frequency (MHz)	Correct Factor (dB)	Reading Level (dBuV)	Emission Level (dBuV/m)	Peak Limit (dBuV/m)	Average Limit (dBuV/m)	Result
01 (Peak)	2390.000	-6.204	68.942	62.738	74.00	54.00	Pass
01 (Peak)	2400.000	-6.124	82.219	76.094	--	--	--
01 (Peak)	2415.300	-6.129	108.471	102.343	--	--	--
01 (Average)	2390.000	-6.204	45.279	39.075	74.00	54.00	Pass
01 (Average)	2400.000	-6.124	60.220	54.095	--	--	--
01 (Average)	2413.600	-6.127	96.814	90.687	--	--	--

Figure Channel 01: Horizontal (Peak)

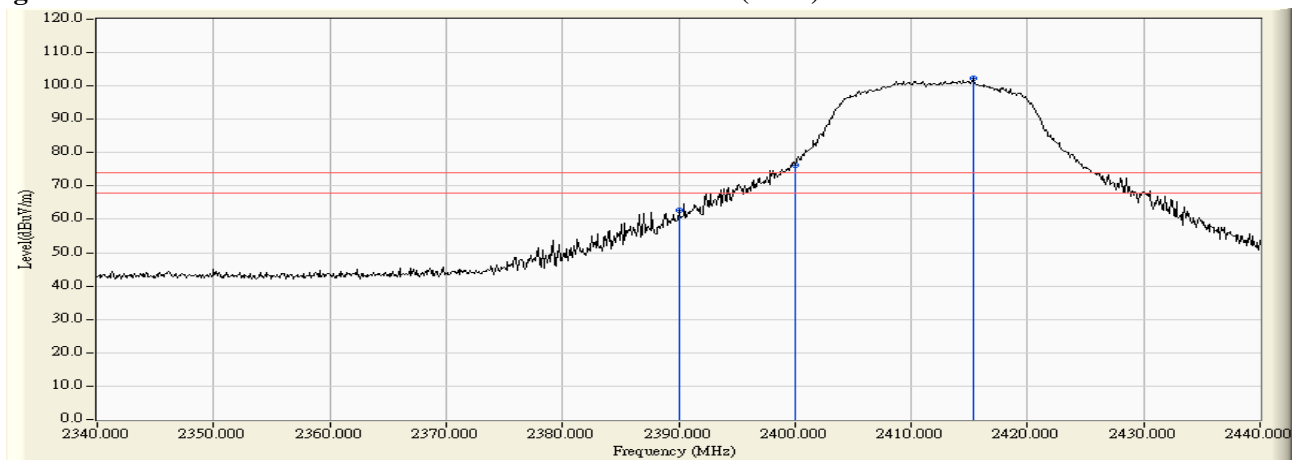
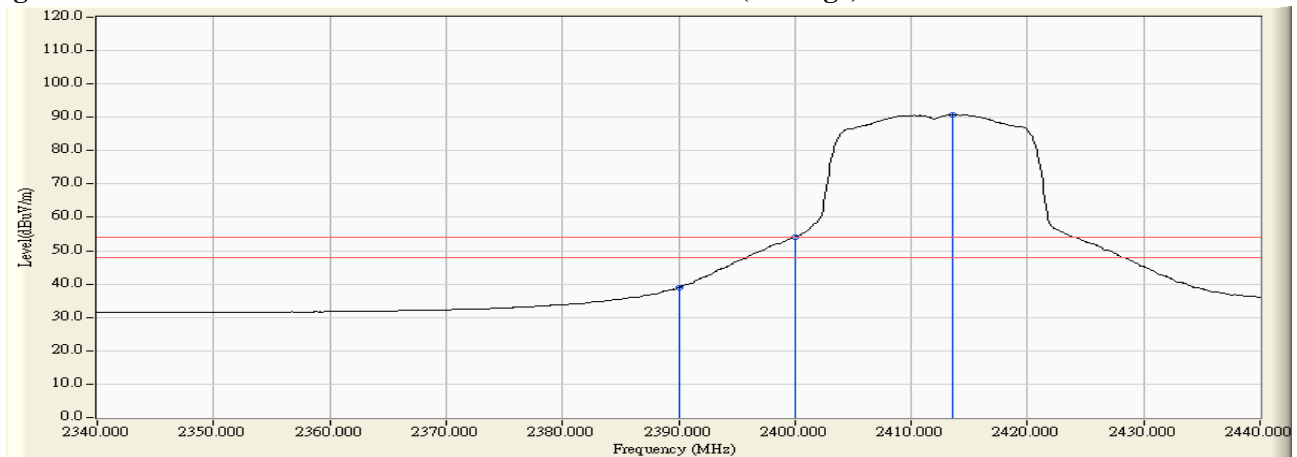

Figure Channel 01: Horizontal (Average)



Note:

1. All readings above 1GHz are performed with peak and/or average measurements as necessary.
2. Peak measurements: RBW = 1MHz, VBW = 3 MHz, Sweep: Auto.
3. Average measurements: RBW = 1MHz, VBW = 10 Hz, Sweep: Auto.
4. “ * ”, means this data is the worst emission level.
5. Measurement Level = Reading Level + Correct Factor.
6. The average measurement was not performed when the peak measured data under the limit of average detection.

Product : TABLET PC
 Test Item : Band Edge Data
 Test Site : No.3 OATS
 Test Mode : Mode 2: Transmit (802.11g 6Mbps)

RF Radiated Measurement (Vertical):

Channel No.	Frequency (MHz)	Correct Factor (dB)	Reading Level (dBuV)	Emission Level (dBuV/m)	Peak Limit (dBuV/m)	Average Limit (dBuV/m)	Result
01 (Peak)	2388.300	4.412	66.346	70.757	74.00	54.00	Pass
01 (Peak)	2390.000	4.426	61.119	65.545	74.00	54.00	Pass
01 (Peak)	2400.000	4.497	83.604	88.101	--	--	--
01 (Peak)	2414.100	4.484	109.395	113.878	--	--	--
01 (Average)	2390.000	4.426	46.323	50.749	74.00	54.00	Pass
01 (Average)	2400.000	4.497	62.870	67.367	--	--	--
01 (Average)	2413.500	4.484	98.998	103.482	--	--	--

Figure Channel 01: Vertical (Peak)

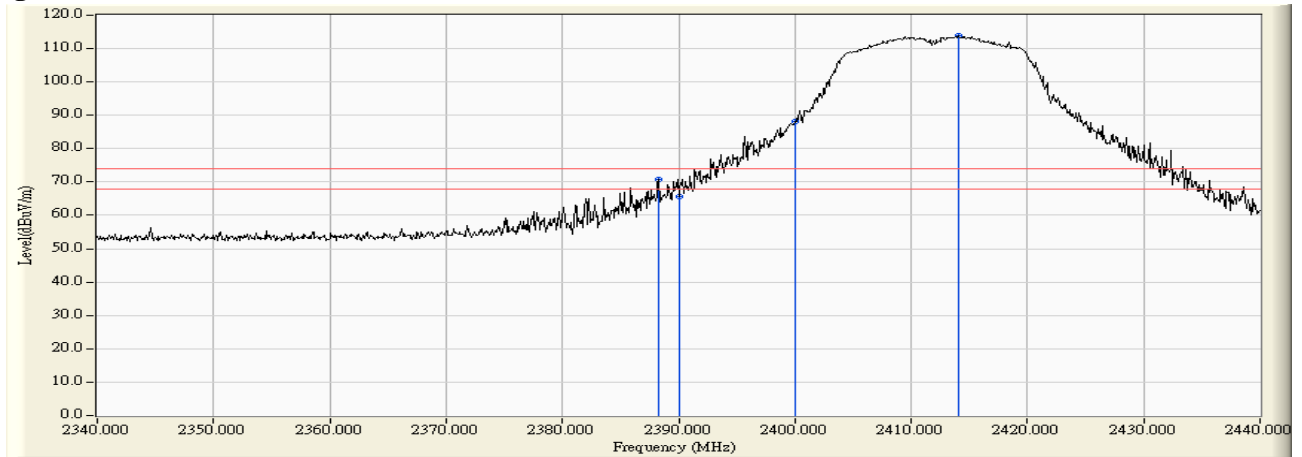
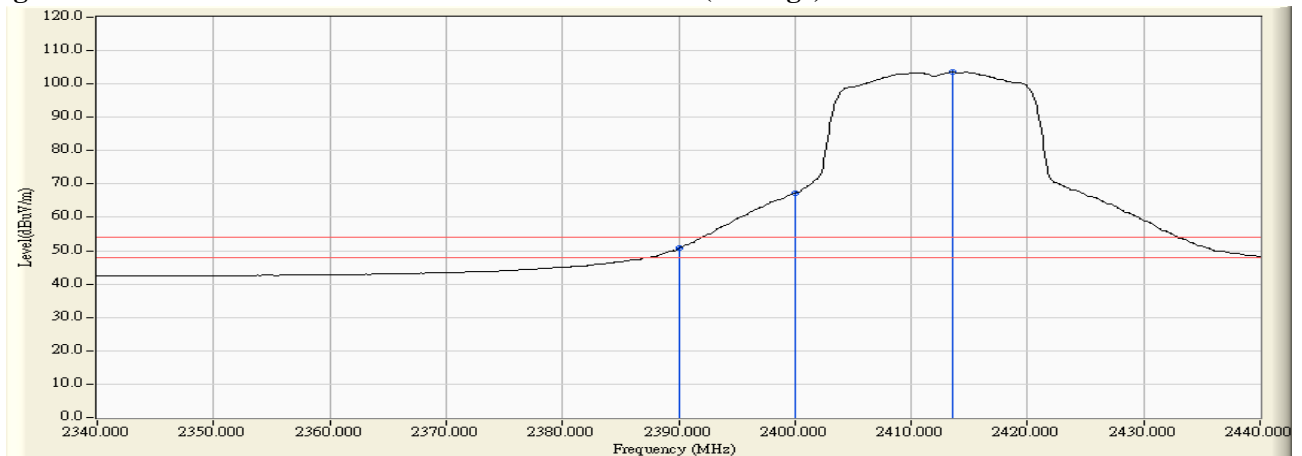

Figure Channel 01: Vertical (Average)



Note:

1. All readings above 1GHz are performed with peak and/or average measurements as necessary.
2. Peak measurements: RBW = 1MHz, VBW = 3 MHz, Sweep: Auto.
3. Average measurements: RBW = 1MHz, VBW = 10 Hz, Sweep: Auto.
4. “ * ”, means this data is the worst emission level.
5. Measurement Level = Reading Level + Correct Factor.
6. The average measurement was not performed when the peak measured data under the limit of average detection.

Product : TABLET PC
 Test Item : Band Edge Data
 Test Site : No.3 OATS
 Test Mode : Mode 2: Transmit (802.11g 6Mbps)

RF Radiated Measurement (Horizontal):

Channel No.	Frequency (MHz)	Correct Factor (dB)	Reading Level (dBuV)	Emission Level (dBuV/m)	Peak Limit (dBuV/m)	Average Limit (dBuV/m)	Result
11 (Peak)	2458.600	-6.115	107.045	100.930	--	--	--
11 (Peak)	2483.500	-6.296	64.093	57.797	74.00	54.00	Pass
11 (Peak)	2484.500	-6.298	64.675	58.377	74.00	54.00	Pass
11 (Average)	2464.100	-6.170	96.296	90.126	--	--	--
11 (Average)	2483.500	-6.296	45.570	39.274	74.00	54.00	Pass

Figure Channel 11: Horizontal (Peak)

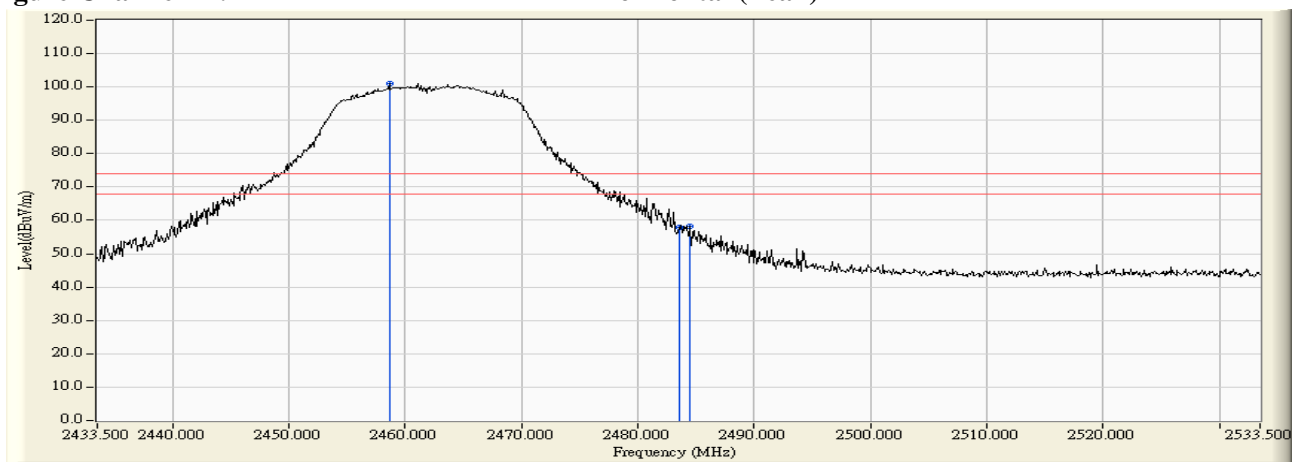
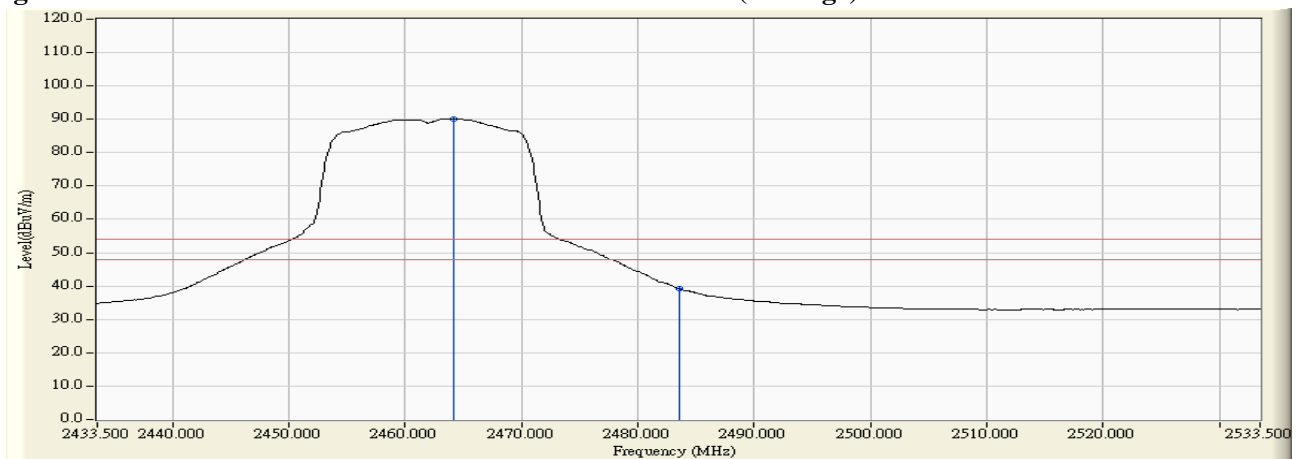

Figure Channel 11: Horizontal (Average)



Note:

1. All readings above 1GHz are performed with peak and/or average measurements as necessary.
2. Peak measurements: RBW = 1MHz, VBW = 3 MHz, Sweep: Auto.
3. Average measurements: RBW = 1MHz, VBW = 10 Hz, Sweep: Auto.
4. “ * ”, means this data is the worst emission level.
5. Measurement Level = Reading Level + Correct Factor.
6. The average measurement was not performed when the peak measured data under the limit of average detection.

Product : TABLET PC
 Test Item : Band Edge Data
 Test Site : No.3 OATS
 Test Mode : Mode 2: Transmit (802.11g 6Mbps)

RF Radiated Measurement (Vertical):

Channel No.	Frequency (MHz)	Correct Factor (dB)	Reading Level (dBuV)	Emission Level (dBuV/m)	Peak Limit (dBuV/m)	Average Limit (dBuV/m)	Result
11 (Peak)	2464.100	4.401	108.031	112.432	--	--	--
11 (Peak)	2483.500	4.260	63.431	67.691	74.00	54.00	Pass
11 (Peak)	2485.400	4.252	64.223	68.476	74.00	54.00	Pass
11 (Average)	2463.900	4.403	97.567	101.970	74.00	54.00	Pass
11 (Average)	2483.500	4.260	47.328	51.588	--	--	--

Figure Channel 11: Vertical (Peak)

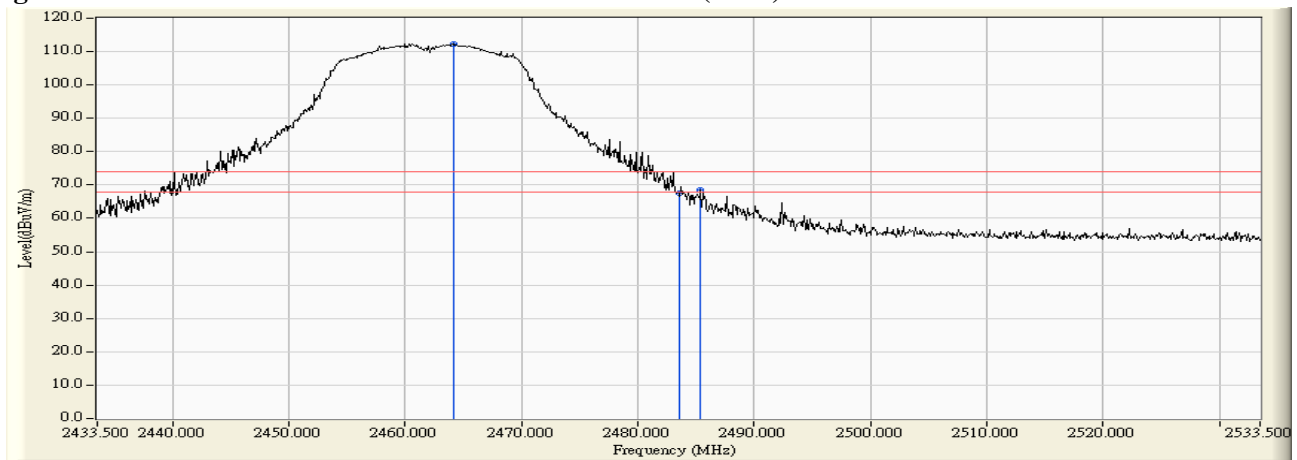
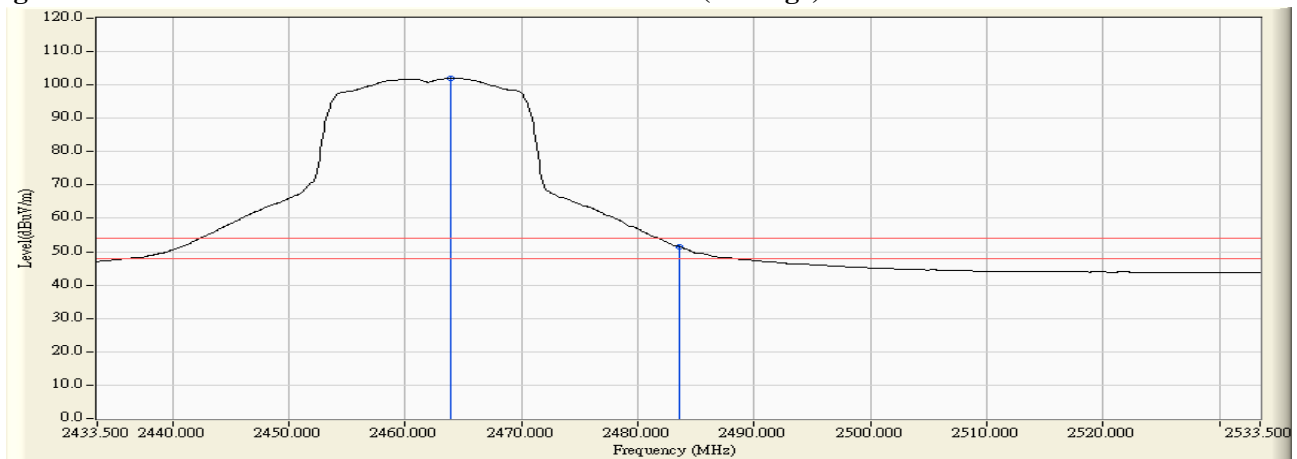

Figure Channel 11: Vertical (Average)



Note:

1. All readings above 1GHz are performed with peak and/or average measurements as necessary.
2. Peak measurements: RBW = 1MHz, VBW = 3 MHz, Sweep: Auto.
3. Average measurements: RBW = 1MHz, VBW = 10 Hz, Sweep: Auto.
4. “ * ”, means this data is the worst emission level.
5. Measurement Level = Reading Level + Correct Factor.
6. The average measurement was not performed when the peak measured data under the limit of average detection.

Product : TABLET PC
 Test Item : Band Edge Data
 Test Site : No.3 OATS
 Test Mode : Mode 3: Transmit (802.11n MCS0 7.2Mbps 20M-BW)

RF Radiated Measurement (Horizontal):

Channel No.	Frequency (MHz)	Correct Factor (dB)	Reading Level (dBuV)	Emission Level (dBuV/m)	Peak Limit (dBuV/m)	Average Limit (dBuV/m)	Result
01 (Peak)	2389.200	-6.211	69.189	62.978	74.00	54.00	Pass
01 (Peak)	2390.000	-6.204	68.254	62.050	74.00	54.00	Pass
01 (Peak)	2400.000	-6.124	84.088	77.963	--	--	--
01 (Peak)	2413.600	-6.127	107.456	101.329	--	--	--
01 (Average)	2390.000	-6.204	47.098	40.894	74.00	54.00	Pass
01 (Average)	2400.000	-6.124	61.584	55.459	--	--	--
01 (Average)	2413.500	-6.127	96.329	90.202	--	--	--

Figure Channel 01: Horizontal (Peak)

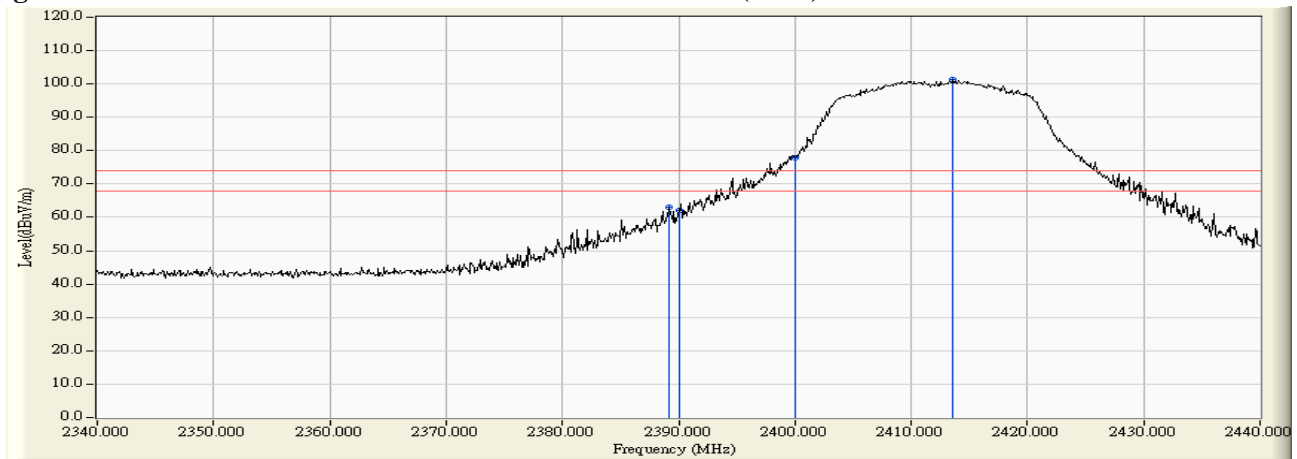
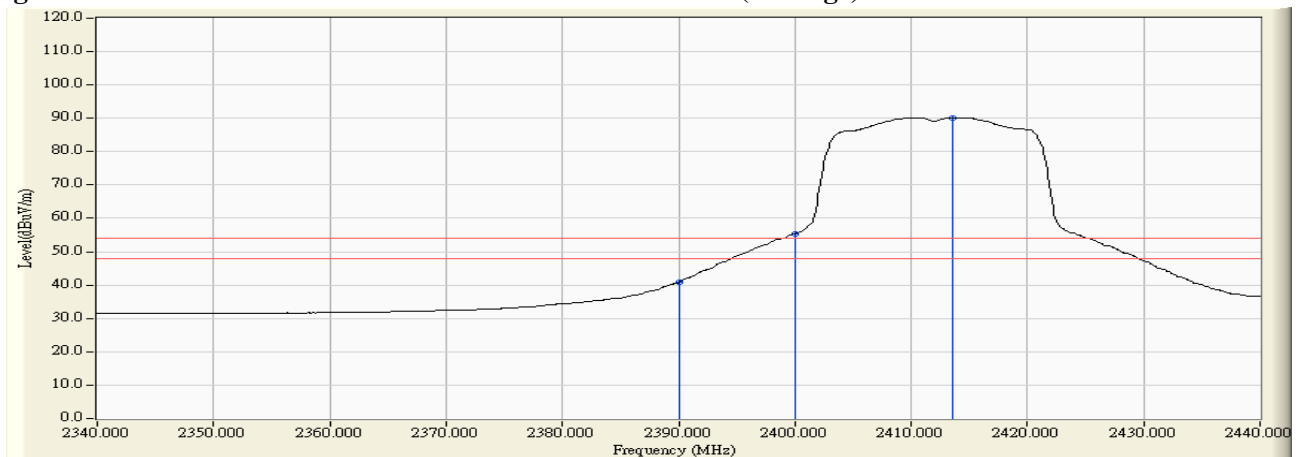

Figure Channel 01: Horizontal (Average)



Note:

1. All readings above 1GHz are performed with peak and/or average measurements as necessary.
2. Peak measurements: RBW = 1MHz, VBW = 3 MHz, Sweep: Auto.
3. Average measurements: RBW = 1MHz, VBW = 10 Hz, Sweep: Auto.
4. “ * ”, means this data is the worst emission level.
5. Measurement Level = Reading Level + Correct Factor.
6. The average measurement was not performed when the peak measured data under the limit of average detection.

Product : TABLET PC
 Test Item : Band Edge Data
 Test Site : No.3 OATS
 Test Mode : Mode 3: Transmit (802.11n MCS0 7.2Mbps 20M-BW)

RF Radiated Measurement (Vertical):

Channel No.	Frequency (MHz)	Correct Factor (dB)	Reading Level (dBuV)	Emission Level (dBuV/m)	Peak Limit (dBuV/m)	Average Limit (dBuV/m)	Result
01 (Peak)	2390.000	4.426	68.269	72.695	74.00	54.00	Pass
01 (Peak)	2400.000	4.497	84.568	89.065	--	--	--
01 (Peak)	2411.000	4.488	109.485	113.974	--	--	--
01 (Average)	2390.000	4.426	48.574	53.000	74.00	54.00	Pass
01 (Average)	2400.000	4.497	64.345	68.842	--	--	--
01 (Average)	2413.800	4.483	98.635	103.119	--	--	--

Figure Channel 01: Vertical (Peak)

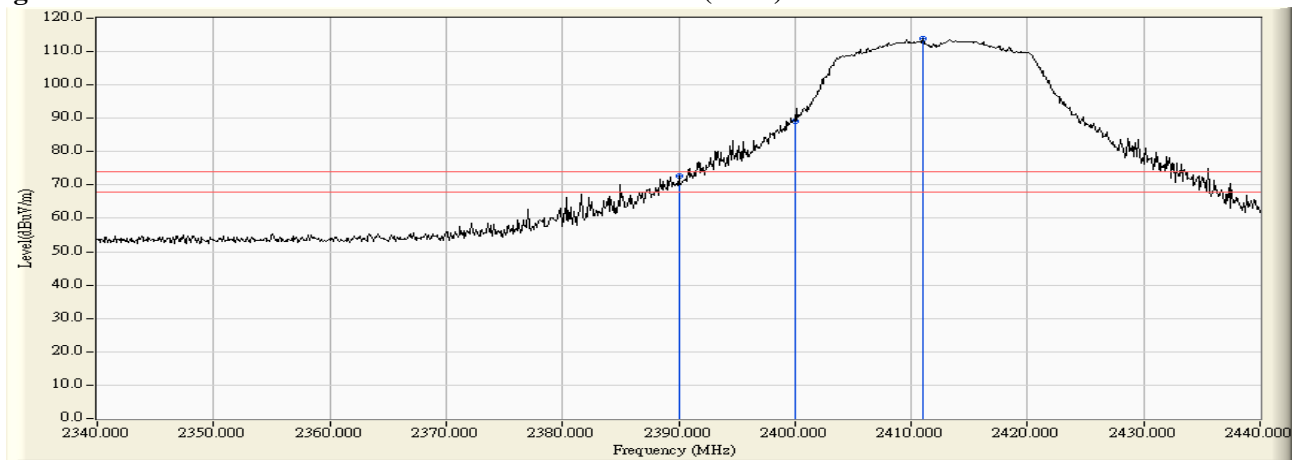
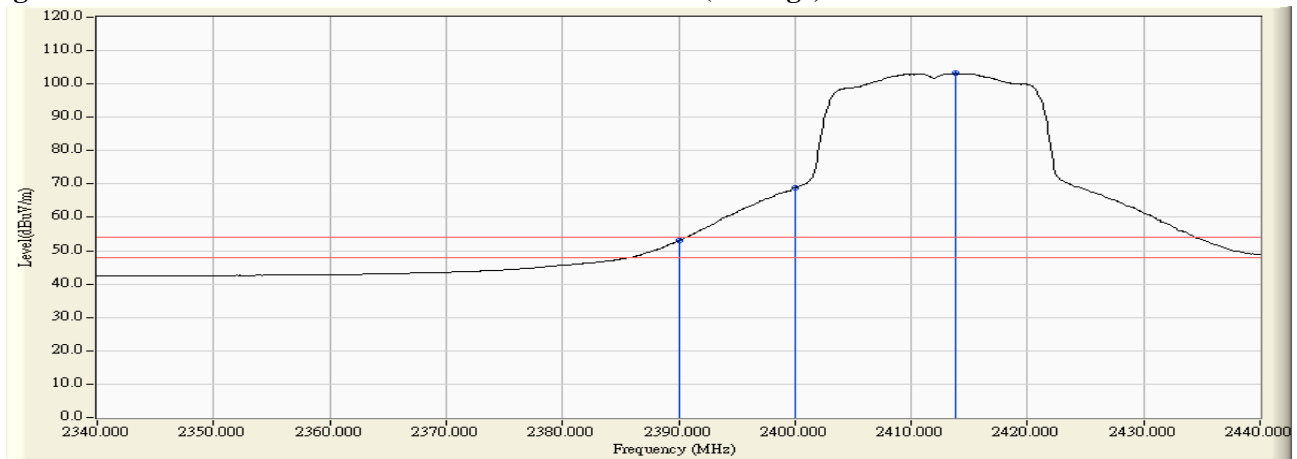

Figure Channel 01: Vertical (Average)



Note:

1. All readings above 1GHz are performed with peak and/or average measurements as necessary.
2. Peak measurements: RBW = 1MHz, VBW = 3 MHz, Sweep: Auto.
3. Average measurements: RBW = 1MHz, VBW = 10 Hz, Sweep: Auto.
4. “ * ”, means this data is the worst emission level.
5. Measurement Level = Reading Level + Correct Factor.
6. The average measurement was not performed when the peak measured data under the limit of average detection.

Product : TABLET PC
 Test Item : Band Edge Data
 Test Site : No.3 OATS
 Test Mode : Mode 3: Transmit (802.11n MCS0 7.2Mbps 20M-BW)

RF Radiated Measurement (Horizontal):

Channel No.	Frequency (MHz)	Correct Factor (dB)	Reading Level (dBuV)	Emission Level (dBuV/m)	Peak Limit (dBuV/m)	Average Limit (dBuV/m)	Result
11 (Peak)	2464.500	-6.174	107.153	100.979	--	--	--
11 (Peak)	2483.500	-6.296	69.908	63.612	74.00	54.00	Pass
11 (Average)	2464.500	-6.174	96.380	90.206	--	--	--
11 (Average)	2483.500	-6.296	48.554	42.258	74.00	54.00	Pass

Figure Channel 11: Horizontal (Peak)

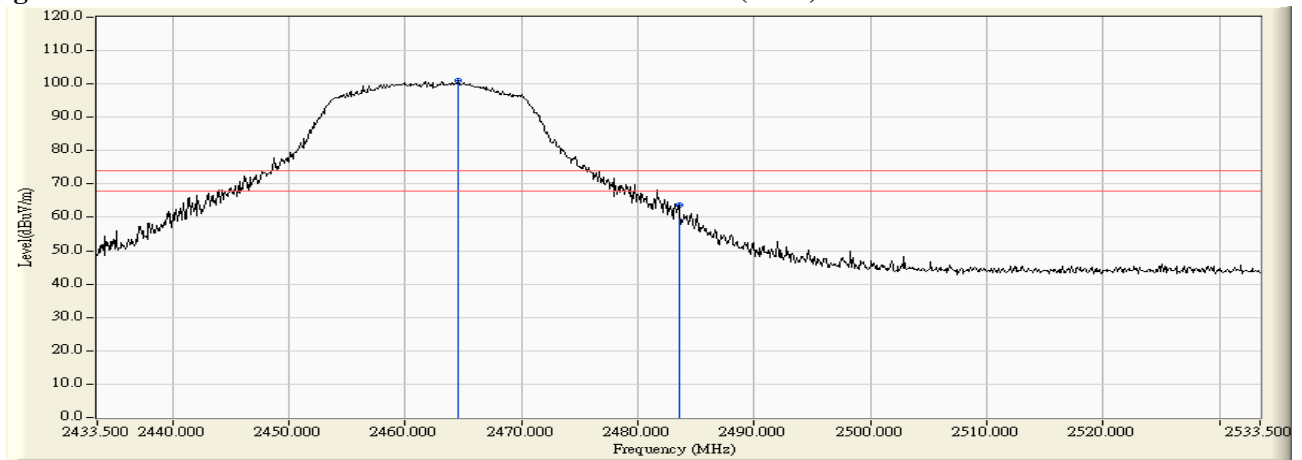
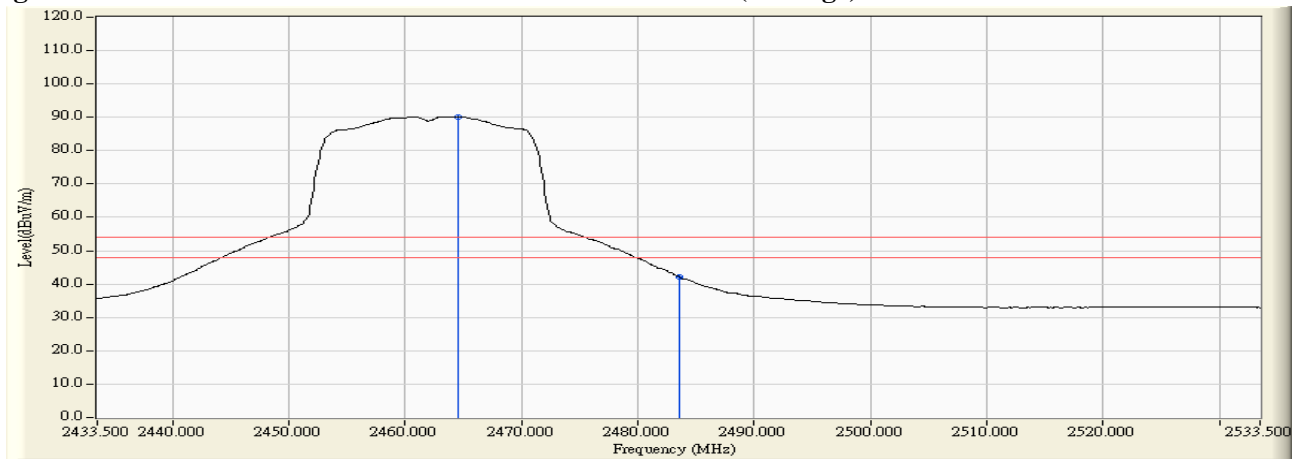

Figure Channel 11: Horizontal (Average)



Note:

1. All readings above 1GHz are performed with peak and/or average measurements as necessary.
2. Peak measurements: RBW = 1MHz, VBW = 3 MHz, Sweep: Auto.
3. Average measurements: RBW = 1MHz, VBW = 10 Hz, Sweep: Auto.
4. “ * ”, means this data is the worst emission level.
5. Measurement Level = Reading Level + Correct Factor.
6. The average measurement was not performed when the peak measured data under the limit of average detection.

Product : TABLET PC
 Test Item : Band Edge Data
 Test Site : No.3 OATS
 Test Mode : Mode 3: Transmit (802.11n MCS0 7.2Mbps 20M-BW)

RF Radiated Measurement (Vertical):

Channel No.	Frequency (MHz)	Correct Factor (dB)	Reading Level (dBuV)	Emission Level (dBuV/m)	Peak Limit (dBuV/m)	Average Limit (dBuV/m)	Result
11 (Peak)	2464.400	4.397	108.280	112.678	--	--	--
11 (Peak)	2483.500	4.260	67.992	72.252	74.00	54.00	Pass
11 (Peak)	2485.900	4.252	68.480	72.732	74.00	54.00	Pass
11 (Average)	2464.400	4.397	95.789	100.187	--	--	--
11 (Average)	2483.500	4.260	47.201	51.461	74.00	54.00	Pass

Figure Channel 11: Vertical (Peak)

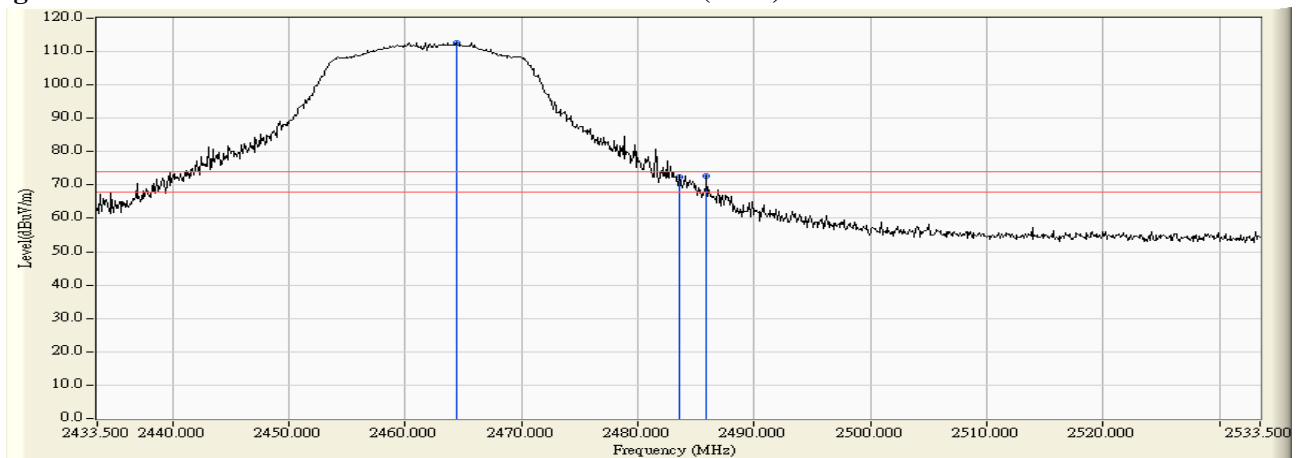
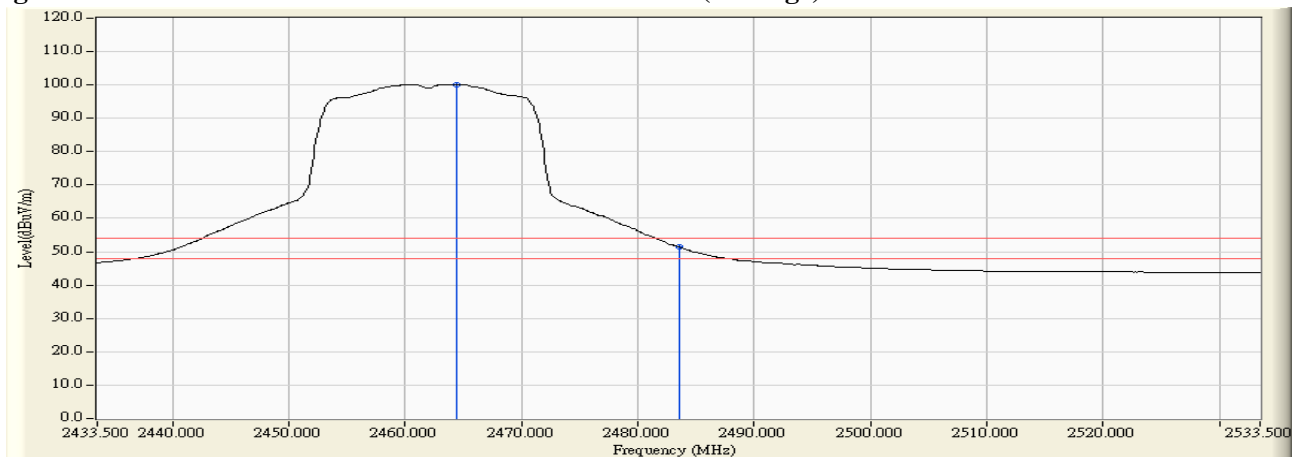

Figure Channel 11: Vertical (Average)



Note:

1. All readings above 1GHz are performed with peak and/or average measurements as necessary.
2. Peak measurements: RBW = 1MHz, VBW = 3 MHz, Sweep: Auto.
3. Average measurements: RBW = 1MHz, VBW = 10 Hz, Sweep: Auto.
4. “ * ”, means this data is the worst emission level.
5. Measurement Level = Reading Level + Correct Factor.
6. The average measurement was not performed when the peak measured data under the limit of average detection.

7. Occupied Bandwidth

7.1. Test Equipment

	Equipment	Manufacturer	Model No./Serial No.	Last Cal.
	Spectrum Analyzer	R&S	FSP40 / 100170	Jun, 2015
	Spectrum Analyzer	Agilent	E4407B / US39440758	Jun, 2015
X	Spectrum Analyzer	Agilent	N9010A / MY48030495	Apr., 2015

Note:

1. All equipments are calibrated with traceable calibrations. Each calibration is traceable to the national or international standards.
2. The test instruments marked with “X” are used to measure the final test results.

7.2. Test Setup

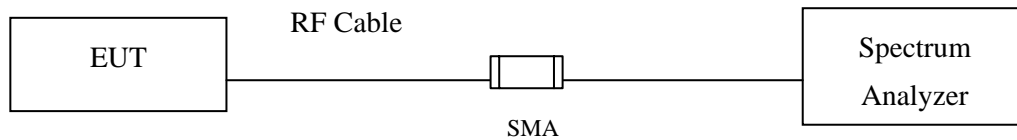

7.3. Limits

The minimum bandwidth shall be at least 500 kHz.

7.4. Test Procedure

The EUT was setup according to ANSI C63.4: 2014; tested according to DTS test procedure of KDB558074 for compliance to FCC 47CFR 15.247 requirements.

7.5. Uncertainty

± 150Hz

7.6. Test Result of Occupied Bandwidth

Product : TABLET PC
 Test Item : Occupied Bandwidth Data
 Test Site : No.3 OATS
 Test Mode : Mode 1: Transmit (802.11b 1Mbps) (2412MHz)

Channel No.	Frequency (MHz)	Measurement Level (kHz)	Required Limit (kHz)	Result
1	2412	9150	>500	Pass

Figure Channel 1:

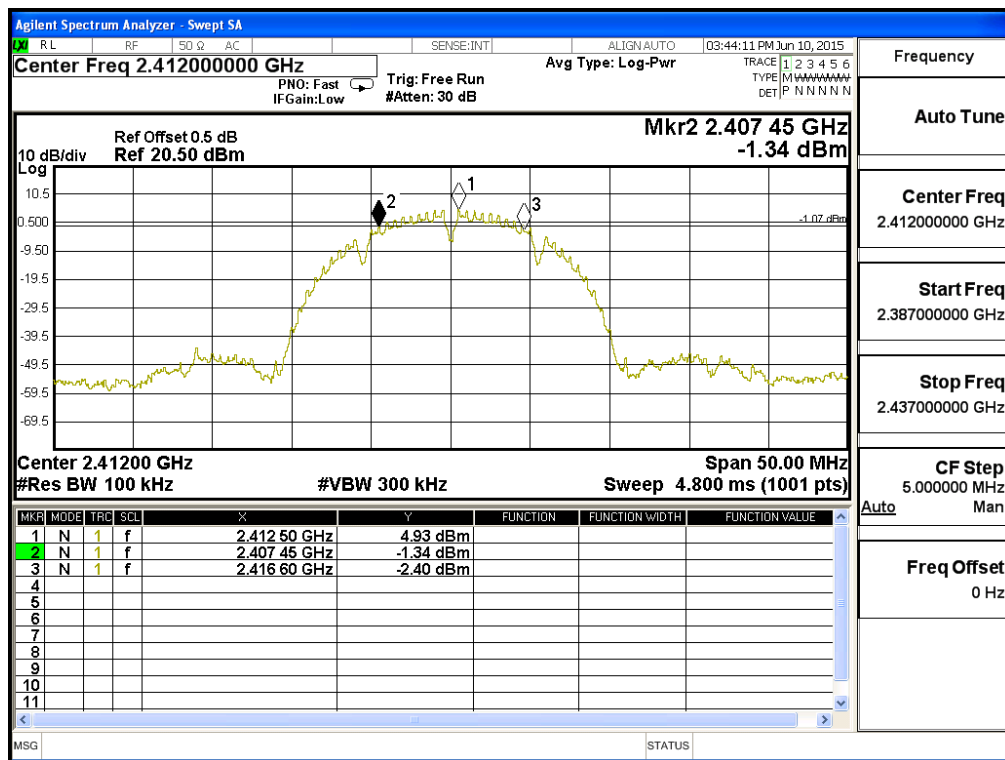

Product : TABLET PC
 Test Item : Occupied Bandwidth Data
 Test Site : No.3 OATS
 Test Mode : Mode 1: Transmit (802.11b 1Mbps) (2437MHz)

Channel No.	Frequency (MHz)	Measurement Level (kHz)	Required Limit (kHz)	Result
6	2437	9200	>500	Pass

Figure Channel 6:

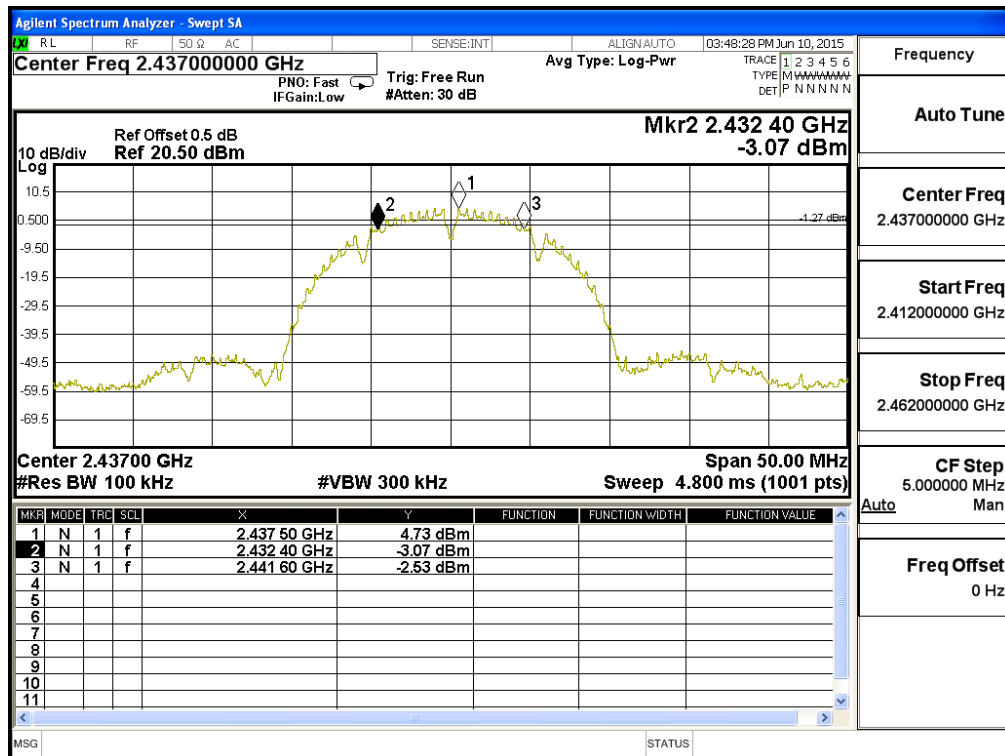

Product : TABLET PC
 Test Item : Occupied Bandwidth Data
 Test Site : No.3 OATS
 Test Mode : Mode 1: Transmit (802.11b 1Mbps) (2462MHz)

Channel No.	Frequency (MHz)	Measurement Level (kHz)	Required Limit (kHz)	Result
11	2462	9200	>500	Pass

Figure Channel 11:

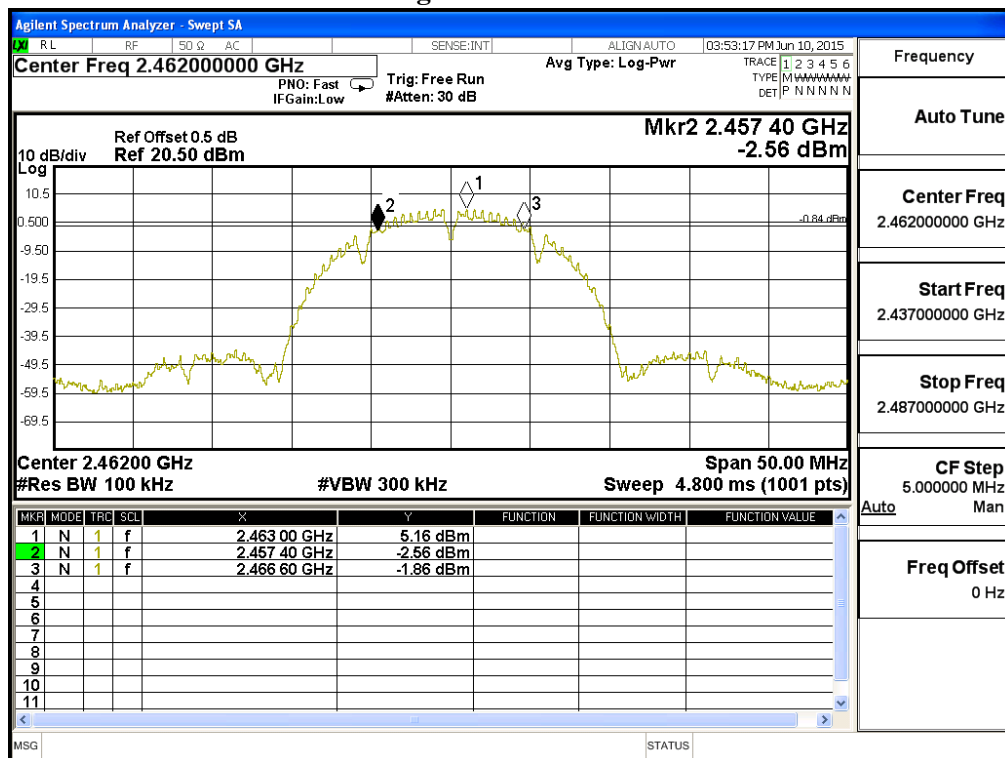

Product : TABLET PC
 Test Item : Occupied Bandwidth Data
 Test Site : No.3 OATS
 Test Mode : Mode 2: Transmit (802.11g 6Mbps) (2412MHz)

Channel No.	Frequency (MHz)	Measurement Level (kHz)	Required Limit (kHz)	Result
1	2412	15200	>500	Pass

Figure Channel 1:

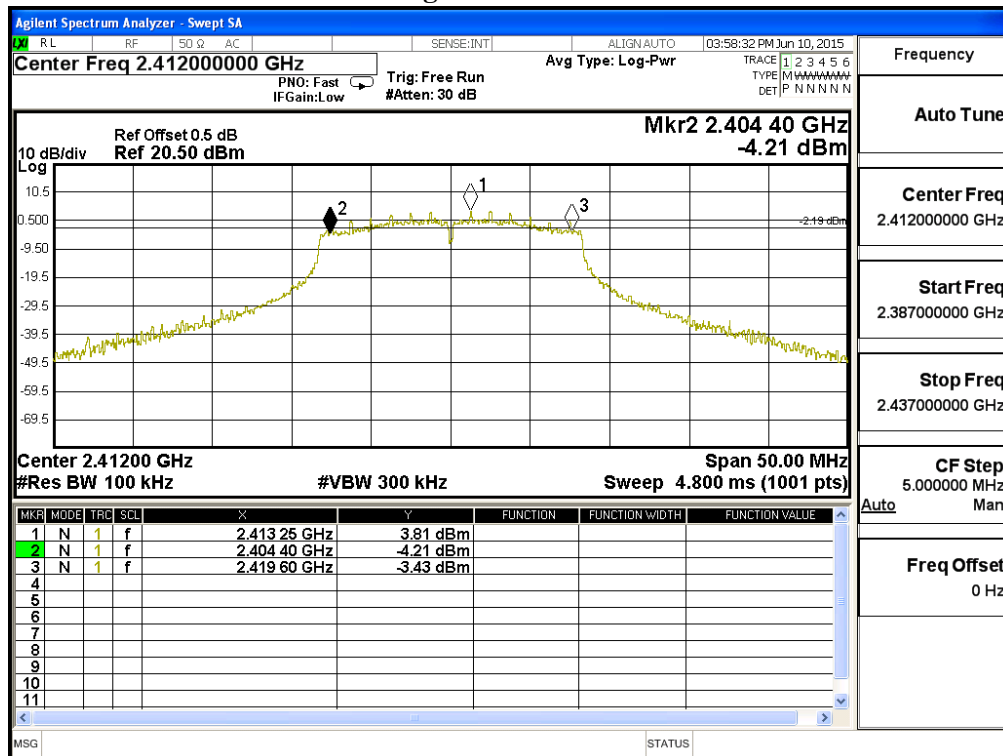

Product : TABLET PC
 Test Item : Occupied Bandwidth Data
 Test Site : No.3 OATS
 Test Mode : Mode 2: Transmit (802.11g 6Mbps) (2437MHz)

Channel No.	Frequency (MHz)	Measurement Level (kHz)	Required Limit (kHz)	Result
6	2437	15200	>500	Pass

Figure Channel 6:

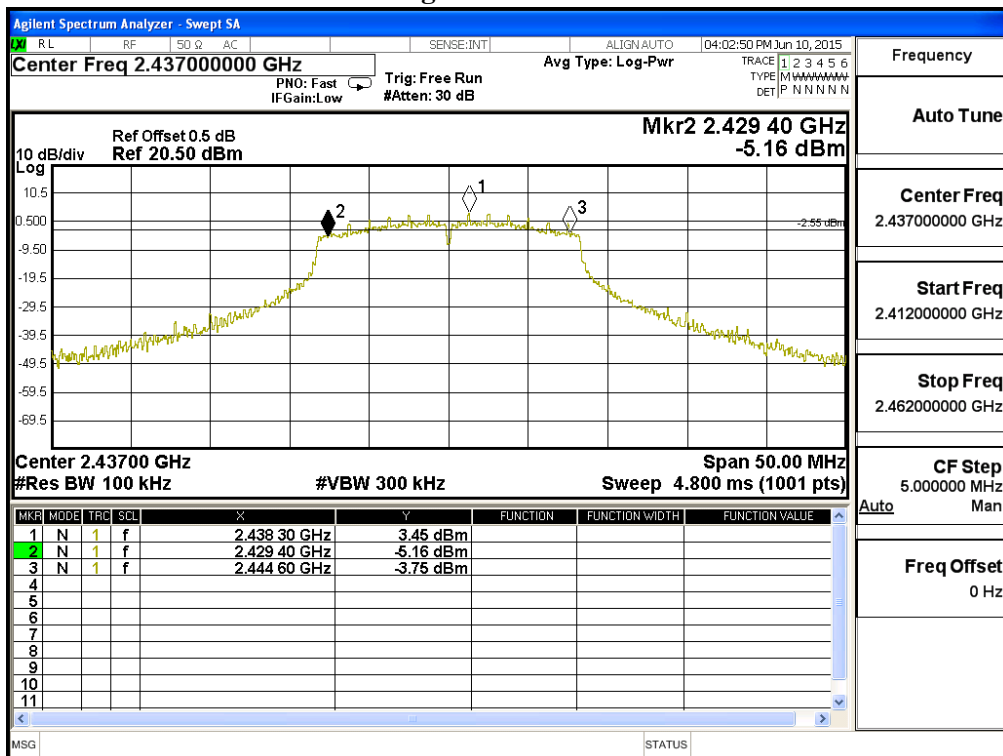

Product : TABLET PC
 Test Item : Occupied Bandwidth Data
 Test Site : No.3 OATS
 Test Mode : Mode 2: Transmit (802.11g 6Mbps) (2462MHz)

Channel No.	Frequency (MHz)	Measurement Level (kHz)	Required Limit (kHz)	Result
11	2462	15200	>500	Pass

Figure Channel 11:

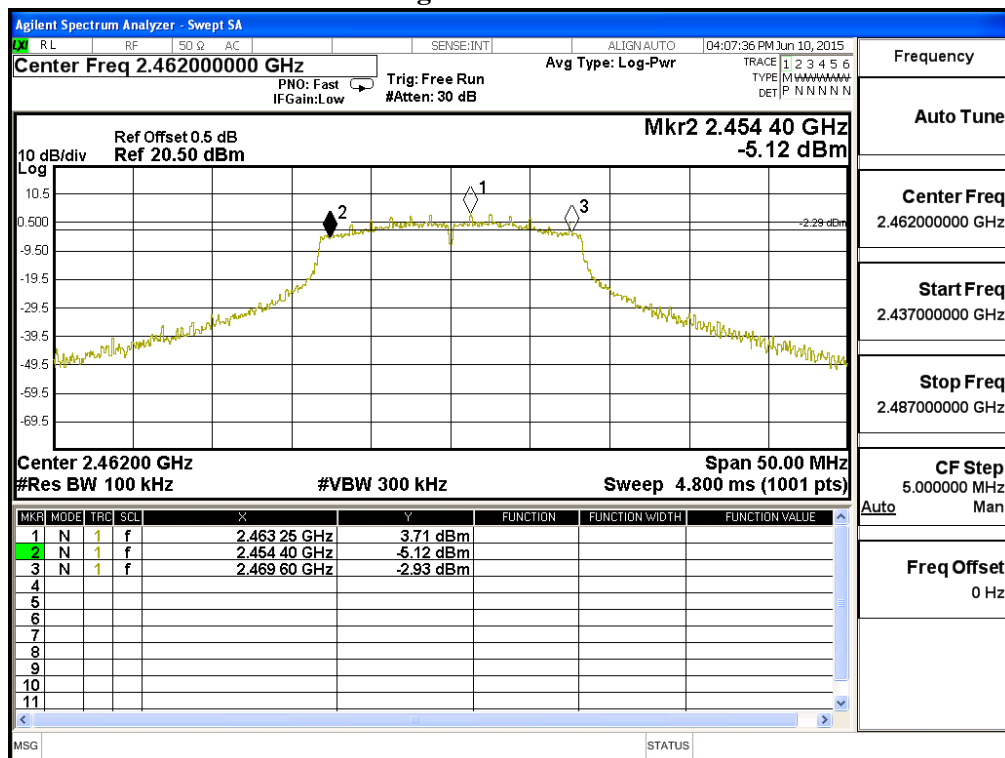

Product : TABLET PC
 Test Item : Occupied Bandwidth Data
 Test Site : No.3 OATS
 Test Mode : Mode 3: Transmit (802.11n MCS0 7.2Mbps 20M-BW) (2437MHz)

Channel No.	Frequency (MHz)	Measurement Level (kHz)	Required Limit (kHz)	Result
6	2437	15150	>500	Pass

Figure Channel 6:

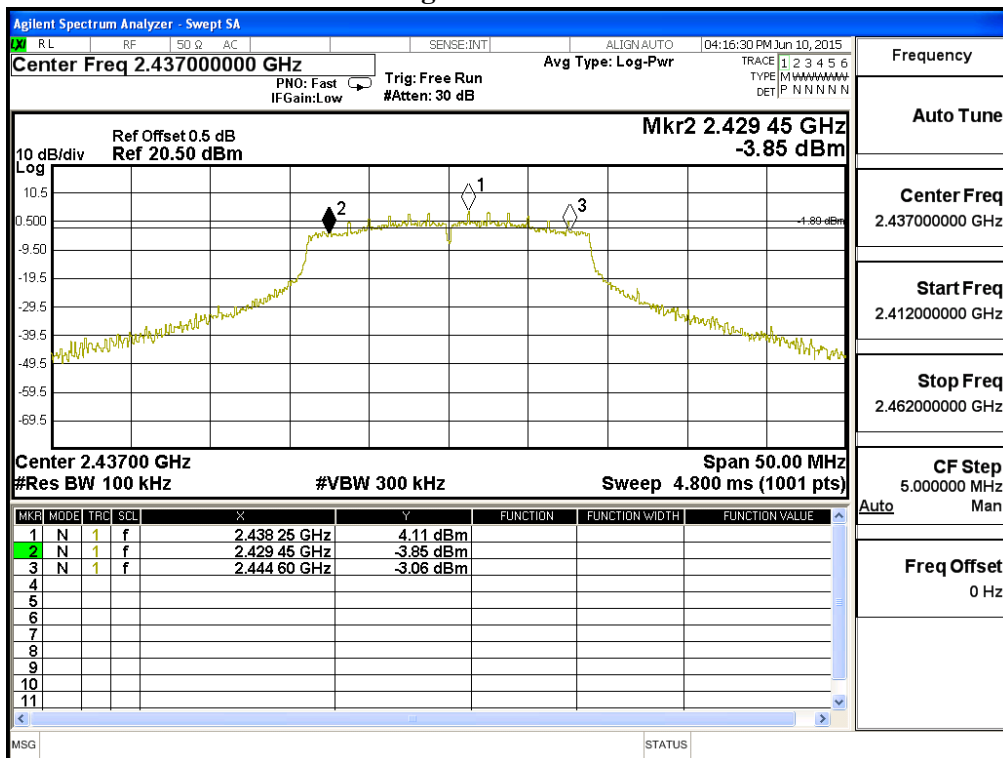

Product : TABLET PC
 Test Item : Occupied Bandwidth Data
 Test Site : No.3 OATS
 Test Mode : Mode 3: Transmit (802.11n MCS0 7.2Mbps 20M-BW) (2462MHz)

Channel No.	Frequency (MHz)	Measurement Level (kHz)	Required Limit (kHz)	Result
11	2462	15200	>500	Pass

Figure Channel 11:

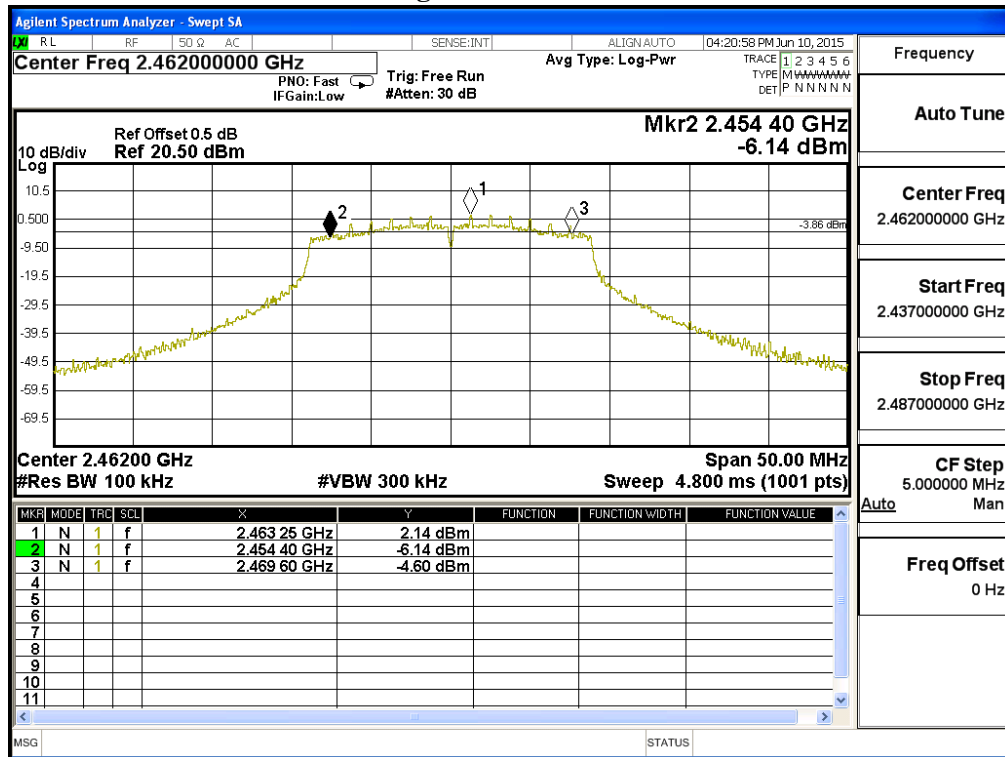

8. Power Density

8.1. Test Equipment

	Equipment	Manufacturer	Model No./Serial No.	Last Cal.
	Spectrum Analyzer	R&S	FSP40 / 100170	Jun, 2015
	Spectrum Analyzer	Agilent	E4407B / US39440758	Jun, 2015
X	Spectrum Analyzer	Agilent	N9010A / MY48030495	Apr., 2015

Note:

1. All equipments are calibrated with traceable calibrations. Each calibration is traceable to the national or international standards.
2. The test instruments marked with “X” are used to measure the final test results.

8.2. Test Setup

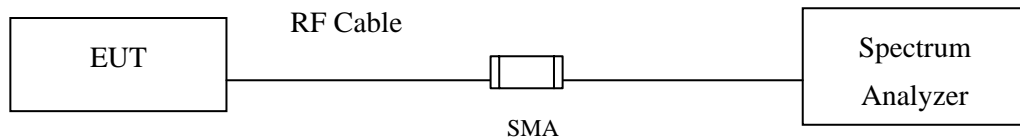

8.3. Limits

The transmitted power density averaged over any 1 second interval shall not be greater +8dBm in any 3kHz bandwidth.

8.4. Test Procedure

The EUT was setup according to ANSI C63.10, 2013; tested according to DTS test procedure of KDB 558074 for compliance to FCC 47CFR 15.247 requirements.

The maximum power spectral density using KDB 558074 section 10.2 PKPSD (peak PSD) method.

8.5. Uncertainty

± 1.27 dB

8.6. Test Result of Power Density

Product : TABLET PC
 Test Item : Power Density Data
 Test Site : No.3 OATS
 Test Mode : Mode 1: Transmit (802.11b 1Mbps) (2412MHz)

Channel No.	Frequency (MHz)	Measure Level (dBm)	Limit (dBm)	Result
1	2412	4.990	< 8dBm	Pass

Figure Channel 1:

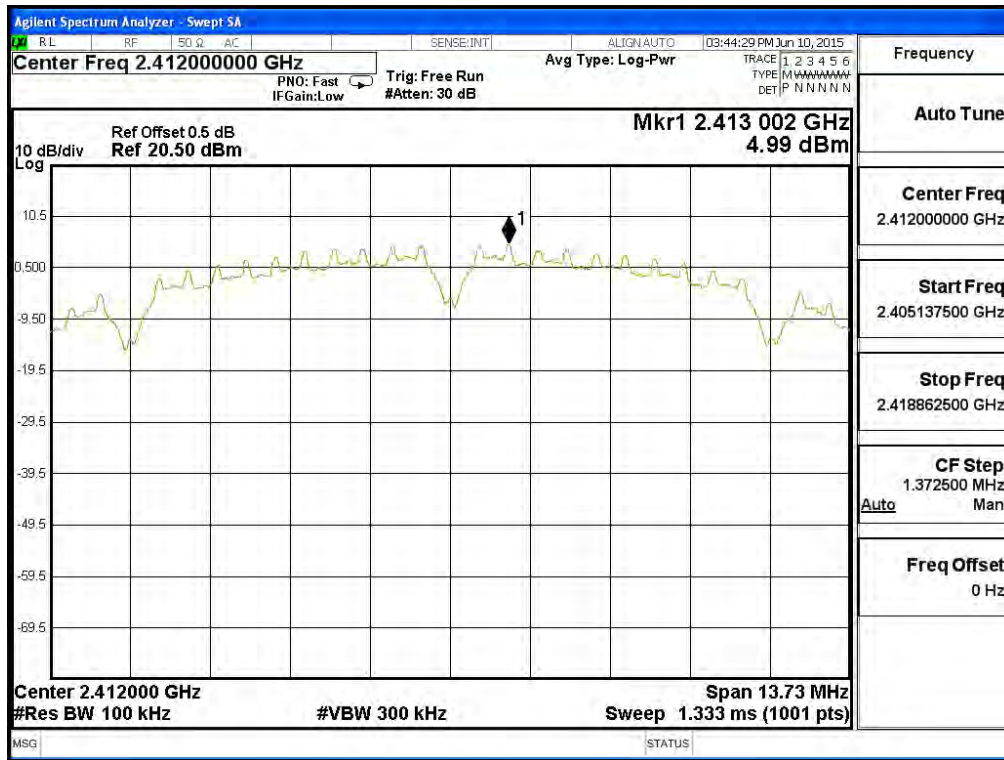

Product : TABLET PC
 Test Item : Power Density Data
 Test Site : No.3 OATS
 Test Mode : Mode 1: Transmit (802.11b 1Mbps) (2462MHz)

Channel No.	Frequency (MHz)	Measurement Level (dBm)	Required Limit (dBm)	Result
11	2462	5.390	< 8dBm	Pass

Figure Channel 11:

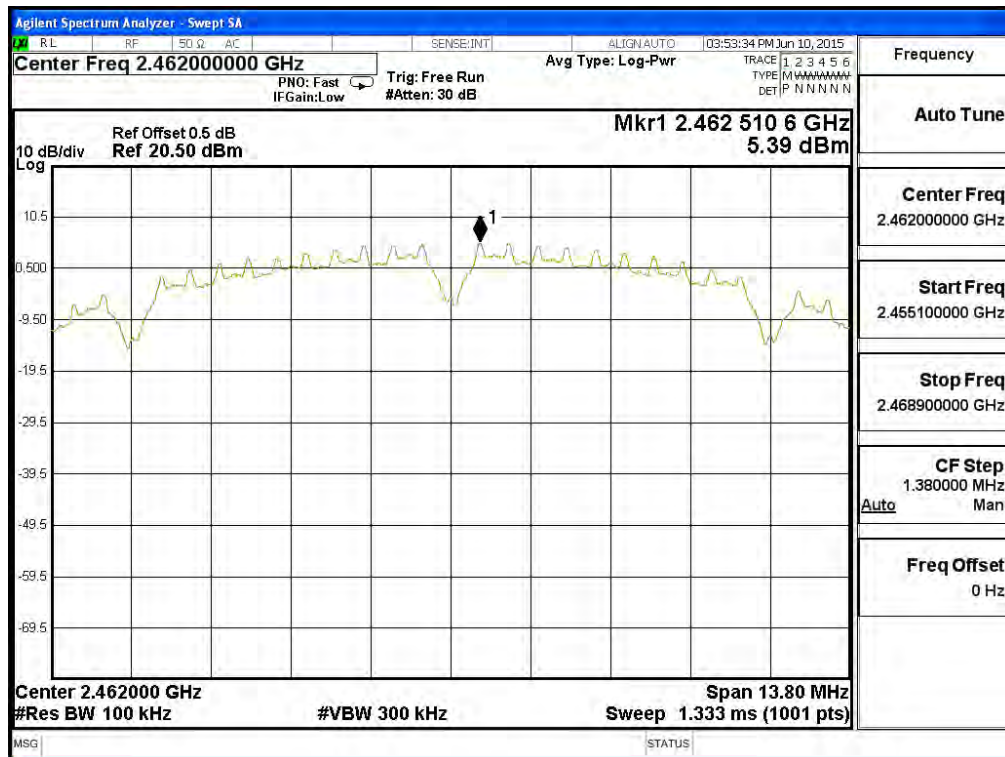

Product : TABLET PC
 Test Item : Power Density Data
 Test Site : No.3 OATS
 Test Mode : Mode 2: Transmit (802.11g 6Mbps) (2412MHz)

Channel No.	Frequency (MHz)	Measure Level (dBm)	Limit (dBm)	Result
1	2412	3.880	< 8dBm	Pass

Figure Channel 1:

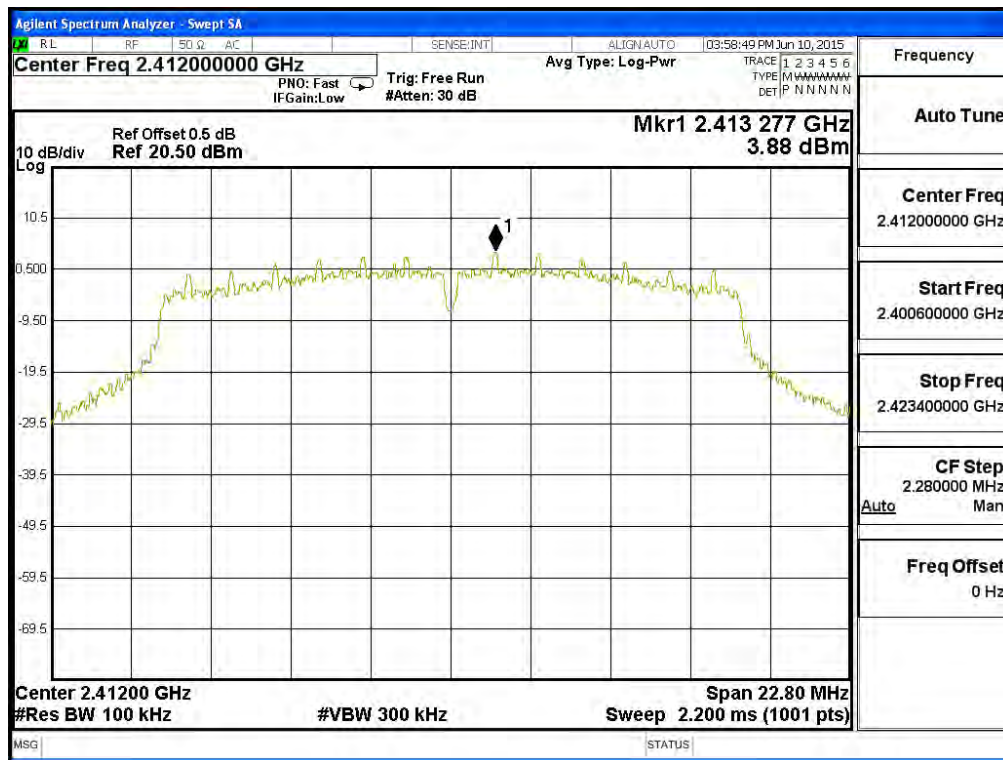

Product : TABLET PC
 Test Item : Power Density Data
 Test Site : No.3OATS
 Test Mode : Mode 2: Transmit (802.11g 6Mbps) (2437MHz)

Channel No.	Frequency (MHz)	Measurement Level (dBm)	Required Limit (dBm)	Result
6	2437	3.500	< 8dBm	Pass

Figure Channel 6:

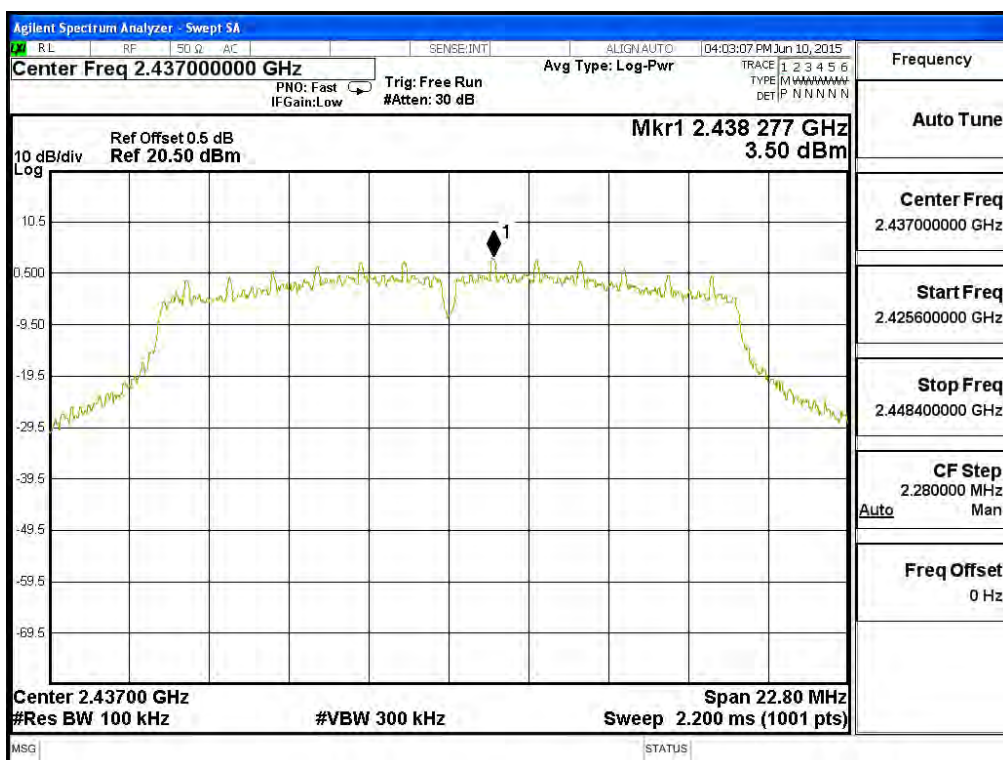

Product : TABLET PC
 Test Item : Power Density Data
 Test Site : No.3 OATS
 Test Mode : Mode 2: Transmit (802.11g 6Mbps) (2462MHz)

Channel No.	Frequency (MHz)	Measurement Level (dBm)	Required Limit (dBm)	Result
11	2462	3.750	< 8dBm	Pass

Figure Channel 11:

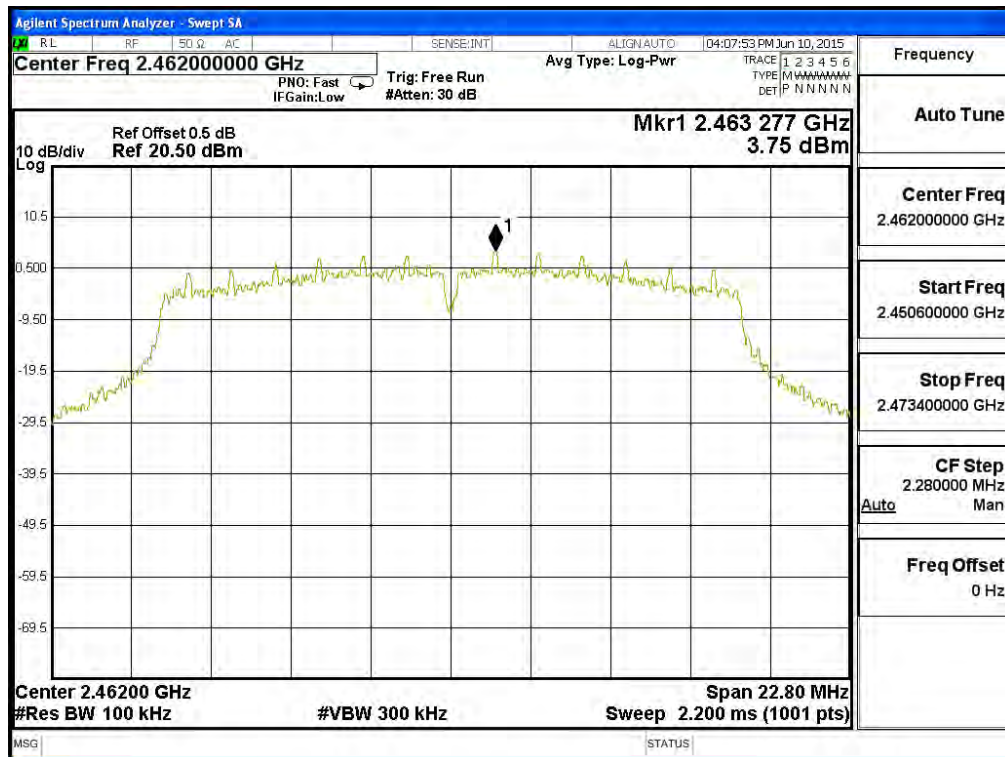

Product : TABLET PC
 Test Item : Power Density Data
 Test Site : No.3 OATS
 Test Mode : Mode 3: Transmit (802.11n MCS0 7.2Mbps 20M-BW) (2412MHz)

Channel No.	Frequency (MHz)	Measure Level (dBm)	Limit (dBm)	Result
1	2412	3.820	< 8dBm	Pass

Figure Channel 1:

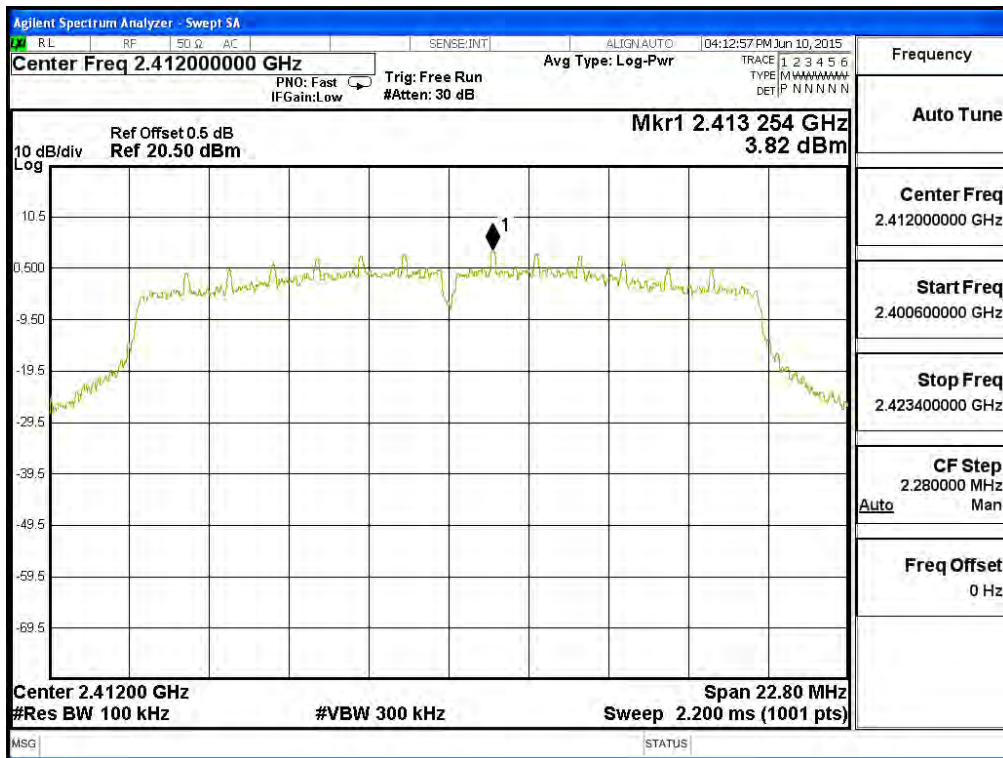

Product : TABLET PC
 Test Item : Power Density Data
 Test Site : No.3OATS
 Test Mode : Mode 3: Transmit (802.11n MCS0 7.2Mbps 20M-BW) (2437MHz)

Channel No.	Frequency (MHz)	Measurement Level (dBm)	Required Limit (dBm)	Result
6	2437	4.110	< 8dBm	Pass

Figure Channel 6:

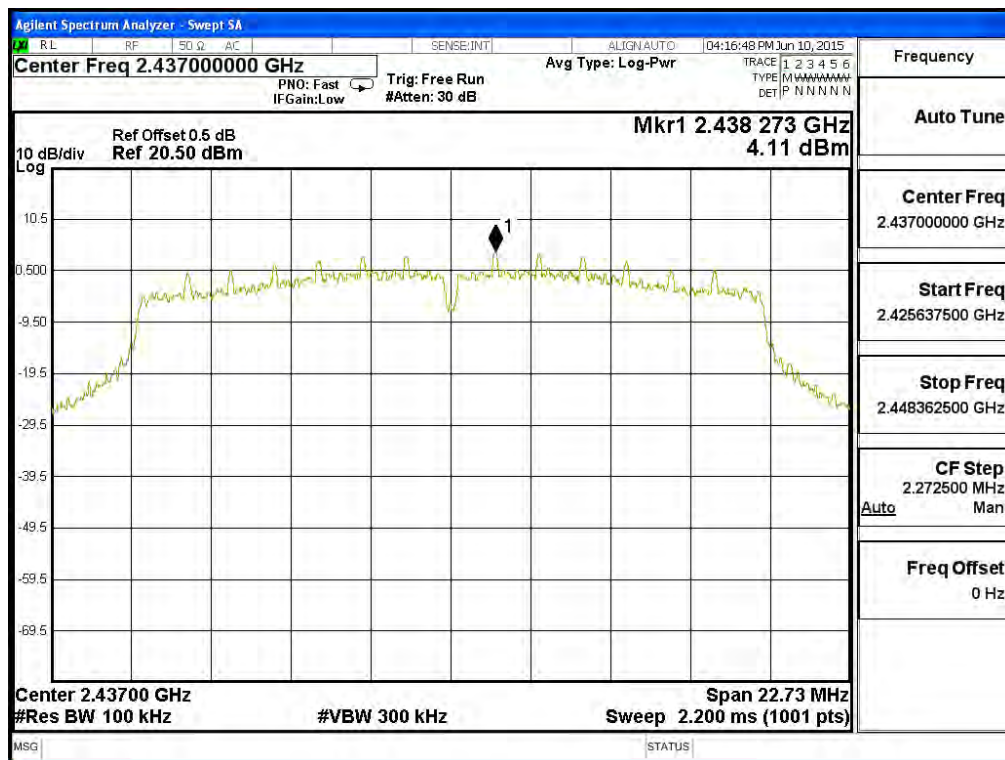

Product : TABLET PC
 Test Item : Power Density Data
 Test Site : No.3 OATS
 Test Mode : Mode 3: Transmit (802.11n MCS0 7.2Mbps 20M-BW) (2462MHz)

Channel No.	Frequency (MHz)	Measurement Level (dBm)	Required Limit (dBm)	Result
11	2462	2.250	< 8dBm	Pass

Figure Channel 11:

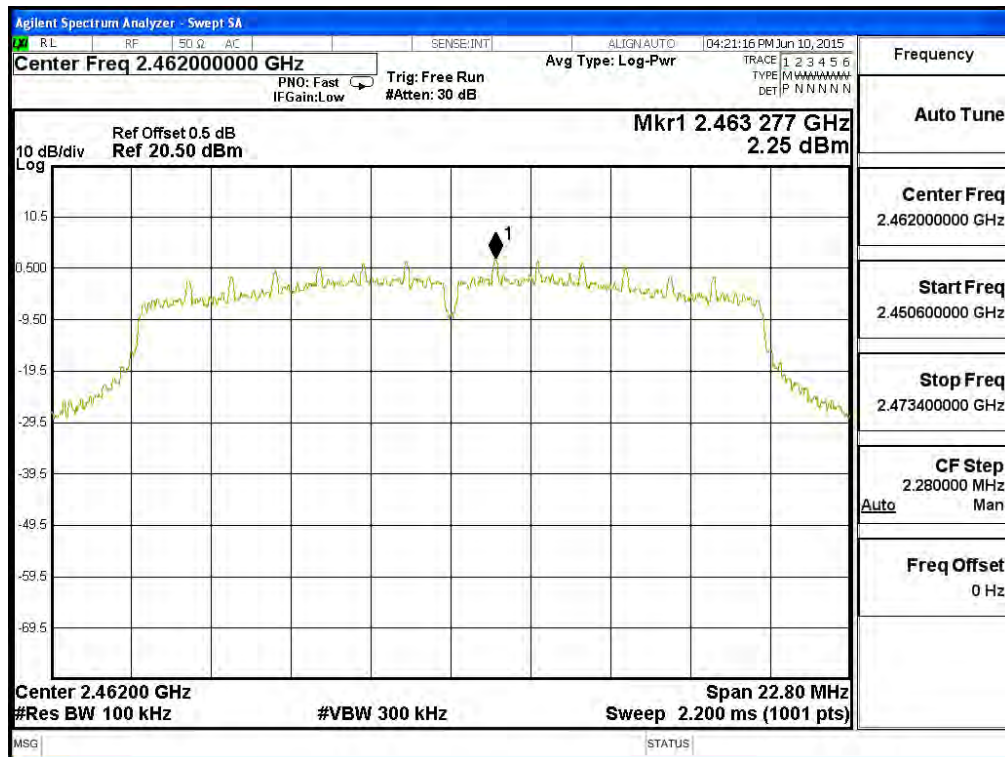

9. EMI Reduction Method During Compliance Testing

No modification was made during testing.