

FCC Test Report

Product Name	TABLET PC
Model No.	PA-501
FCC ID.	2ABTU-PA-501

Applicant	RuggON Corporation
Address	3F., No.10, Ln. 181, Sec. 2, Jiuzong Rd., Neihu Dist., Taipei City , Taiwan

Date of Receipt	Apr. 10, 2015
Issued Date	Jul. 08, 2015
Report No.	1540249R-RFUSP23V00
Report Version	V1.0



The test results relate only to the samples tested.

The test results shown in the test report are traceable to the national/international standard through the calibration report of the equipment and evaluated measurement uncertainty herein.

This report must not be used to claim product endorsement by TAF or any agency of the government.

The test report shall not be reproduced without the written approval of Quietek Corporation.

Test Report

Issued Date: Jul. 08, 2015

Report No.: 1540249R-RFUSP23V00



Product Name	TABLET PC
Applicant	RuggON Corporation
Address	3F., No.10, Ln. 181, Sec. 2, Jiuzong Rd., Neihu Dist., Taipei City , Taiwan
Manufacturer	Ubiquconn Technology, Inc.
Model No.	PA-501
FCC ID.	2ABTU-PA-501
EUT Rated Voltage	AC 100-240V, 50-60Hz
EUT Test Voltage	AC 120V/ 60Hz
Trade Name	RuggON
Applicable Standard	FCC CFR Title 47 Part 15 Subpart C: 2014 ANSI C63.4: 2014, ANSI C63.10: 2013
Test Result	Complied

Documented By : Jinn Chen
(Senior Adm. Specialist / Jinn Chen)

Tested By : Eason chen
(Engineer / Eason Chen)

Approved By : [Signature]
(Director / Vincent Lin)

TABLE OF CONTENTS

Description	Page
1. GENERAL INFORMATION	5
1.1. EUT Description.....	5
1.2. Operational Description.....	7
1.3. Tested System Details.....	8
1.4. Configuration of Tested System	8
1.5. EUT Exercise Software	8
1.6. Test Facility	9
2. CONDUCTED EMISSION	10
2.1. Test Equipment.....	10
2.2. Test Setup	10
2.3. Limits.....	11
2.4. Test Procedure	11
2.5. Uncertainty	11
2.6. Test Result of Conducted Emission.....	12
3. PEAK POWER OUTPUT	14
3.1. Test Equipment.....	14
3.2. Test Setup	14
3.3. Limit	14
3.4. Test Procedure	14
3.5. Uncertainty	14
3.6. Test Result of Peak Power Output.....	15
4. RADIATED EMISSION	17
4.1. Test Equipment.....	17
4.2. Test Setup	17
4.3. Limits.....	18
4.4. Test Procedure	19
4.5. Uncertainty	19
4.6. Test Result of Radiated Emission.....	20
5. RF ANTENNA CONDUCTED TEST	28
5.1. Test Equipment.....	28
5.2. Test Setup	28
5.3. Limits.....	28
5.4. Test Procedure	28
5.5. Uncertainty	28
5.6. Test Result of RF Antenna Conducted Test.....	29
6. BAND EDGE	31
6.1. Test Equipment.....	31
6.2. Test Setup	31
6.3. Limit	32
6.4. Test Procedure	32
6.5. Uncertainty	32

6.6.	Test Result of Band Edge	33
7.	CHANNEL NUMBER.....	41
7.1.	Test Equipment	41
7.2.	Test Setup	41
7.3.	Limit	41
7.4.	Test Procedure	41
7.5.	Uncertainty	41
7.6.	Test Result of Channel Number.....	42
8.	CHANNEL SEPARATION.....	44
8.1.	Test Equipment	44
8.2.	Test Setup	44
8.3.	Limit	44
8.4.	Test Procedure	44
8.5.	Uncertainty	44
8.6.	Test Result of Channel Separation.....	45
9.	DWELL TIME.....	49
9.1.	Test Equipment	49
9.2.	Test Setup	49
9.3.	Limit	49
9.4.	Test Procedure	49
9.5.	Uncertainty	49
9.6.	Test Result of Dwell Time	50
10.	OCCUPIED BANDWIDTH	54
10.1.	Test Equipment	54
10.2.	Test Setup	54
10.3.	Limits.....	54
10.4.	Test Procedure	54
10.5.	Uncertainty	54
10.6.	Test Result of Occupied Bandwidth	55
11.	EMI REDUCTION METHOD DURING COMPLIANCE TESTING	61
Attachment 1: EUT Test Photographs		
Attachment 2: EUT Detailed Photographs		

1. GENERAL INFORMATION

1.1. EUT Description

Product Name	TABLET PC
Trade Name	RuggON
Model No.	PA-501
FCC ID.	2ABTU-PA-501
Frequency Range	2402 – 2480MHz
Channel Number	79
Type of Modulation	FHSS: GFSK(1Mbps) / π /4DQPSK(2Mbps) / 8DPSK(3Mbps)
Antenna Type	PIFA Antenna
Channel Control	Auto
Antenna Gain	Refer to the table “Antenna List”
Power Adapter	MFR: FSP, M/N: FSP065-REB Input: 100-240V~1.5A, 50-60Hz Output: 19V $\overline{=}$ 3.42A Cable Out: Non-shielded, 1.8m

Antenna List

No.	Manufacturer	Part No.	Antenna Type	Peak Gain
1	Ethertronics Inc.	5001791 (Main) 5001799 (Aux)	PIFA	3.8dBi for 2.4 GHz

Note: The antenna of EUT is conforming to FCC 15.203.

Center Frequency of Each Channel:

Channel	Frequency	Channel	Frequency	Channel	Frequency	Channel	Frequency
Channel 00:	2402 MHz	Channel 20:	2422 MHz	Channel 40:	2442 MHz	Channel 60:	2462 MHz
Channel 01:	2403 MHz	Channel 21:	2423 MHz	Channel 41:	2443 MHz	Channel 61:	2463 MHz
Channel 02:	2404 MHz	Channel 22:	2424 MHz	Channel 42:	2444 MHz	Channel 62:	2464 MHz
Channel 03:	2405 MHz	Channel 23:	2425 MHz	Channel 43:	2445 MHz	Channel 63:	2465 MHz
Channel 04:	2406 MHz	Channel 24:	2426 MHz	Channel 44:	2446 MHz	Channel 64:	2466 MHz
Channel 05:	2407 MHz	Channel 25:	2427 MHz	Channel 45:	2447 MHz	Channel 65:	2467 MHz
Channel 06:	2408 MHz	Channel 26:	2428 MHz	Channel 46:	2448 MHz	Channel 66:	2468 MHz
Channel 07:	2409 MHz	Channel 27:	2429 MHz	Channel 47:	2449 MHz	Channel 67:	2469 MHz
Channel 08:	2410 MHz	Channel 28:	2430 MHz	Channel 48:	2450 MHz	Channel 68:	2470 MHz
Channel 09:	2411 MHz	Channel 29:	2431 MHz	Channel 49:	2451 MHz	Channel 69:	2471 MHz
Channel 10:	2412 MHz	Channel 30:	2432 MHz	Channel 50:	2452 MHz	Channel 70:	2472 MHz
Channel 11:	2413 MHz	Channel 31:	2433 MHz	Channel 51:	2453 MHz	Channel 71:	2473 MHz
Channel 12:	2414 MHz	Channel 32:	2434 MHz	Channel 52:	2454 MHz	Channel 72:	2474 MHz
Channel 13:	2415 MHz	Channel 33:	2435 MHz	Channel 53:	2455 MHz	Channel 73:	2475 MHz
Channel 14:	2416 MHz	Channel 34:	2436 MHz	Channel 54:	2456 MHz	Channel 74:	2476 MHz
Channel 15:	2417 MHz	Channel 35:	2437 MHz	Channel 55:	2457 MHz	Channel 75:	2477 MHz
Channel 16:	2418 MHz	Channel 36:	2438 MHz	Channel 56:	2458 MHz	Channel 76:	2478 MHz
Channel 17:	2419 MHz	Channel 37:	2439 MHz	Channel 57:	2459 MHz	Channel 77:	2479 MHz
Channel 18:	2420 MHz	Channel 38:	2440 MHz	Channel 58:	2460 MHz	Channel 78:	2480 MHz
Channel 19:	2421 MHz	Channel 39:	2441 MHz	Channel 59:	2461 MHz		

Note:

1. The EUT is a TABLET PC with a built-in WLAN , Bluetooth and NFC transceiver, this report for Bluetooth.
2. These tests were conducted on a sample for the purpose of demonstrating compliance of Bluetooth transmitter with Part 15 Subpart C Paragraph 15.247 for spread spectrum devices.
3. Regarding to the operation frequency, the lowest, middle and highest frequency are selected to perform the test.
4. The radiation measurements are performed in X, Y, Z axis positioning. Only the worst case is shown in the report.
5. Bluetooth operation was evaluated at both 1Mb/s and 3Mb/s data rates. 2Mb/s data rate was found, through pre-testing, to produce emissions similar to those for 3Mb/s.

Test Mode	Mode 1: Transmit - 1Mbps (GFSK) Mode 2: Transmit - 3Mbps (8DPSK)
-----------	---

1.3. Tested System Details

The types for all equipment, plus descriptions of all cables used in the tested system (including inserted cards) are:

	Product	Manufacturer	Model No.	Serial No.	Power Cord
(1)	Notebook PC	DELL	PPT	N/A	Non-Shielded, 0.8m
(2)	Monitor	DELL	ST2320L	N/A	N/A
(3)	FLASH	Transcend	JetFlash110	155422-2931	Non-Shielded, 1.8m
(4)	Earphone	AIWA	N/A	N/A	N/A

Signal Cable Type	Signal cable Description
A	RS-232 Cable
B	HDMI Cable
C	Earphone Cable
D	Micro USB Cable
E	RJ45 Cable

1.4. Configuration of Tested System

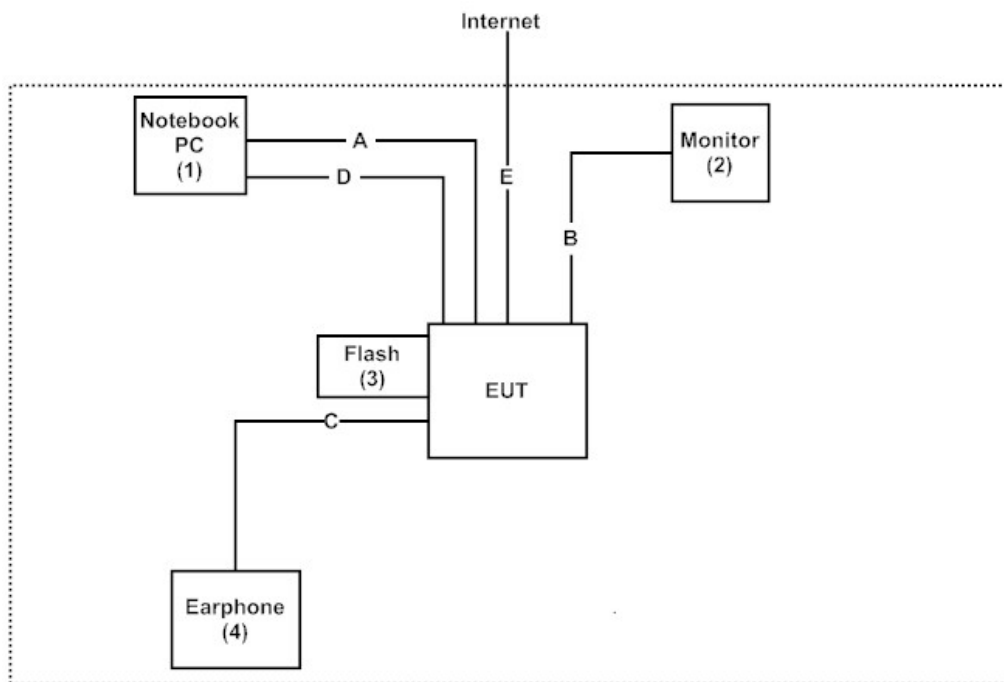

1.5. EUT Exercise Software

- 1 Setup the EUT as shown in Section 1.4.
- 2 Execute software “Terminal Euulator V1.0.45” on the Notebook PC.
- 3 Configure the test mode, the test channel, and the data rate.
- 4 Press “OK” to start the continuous Transmit.
- 5 Verify that the EUT works properly.

1.6. Test Facility

Ambient conditions in the laboratory:

Items	Required (IEC 68-1)	Actual
Temperature (°C)	15-35	20-35
Humidity (%RH)	25-75	30-65
Barometric pressure (mbar)	860-1060	950-1000

The related certificate for our laboratories about the test site and management system can be downloaded from QuieTek Corporation's Web Site: <http://www.quietek.com/chinese/about/certificates.aspx?bval=5>
 The address and introduction of QuieTek Corporation's laboratories can be founded in our Web site: <http://www.quietek.com/>

Site Description: File on
 Federal Communications Commission
 FCC Engineering Laboratory
 7435 Oakland Mills Road
 Columbia, MD 21046
 Registration Number: 92195

Site Name: Quietek Corporation
 Site Address: No.5-22, Ruishukeng,
 Linkou Dist. New Taipei City 24451,
 Taiwan, R.O.C.
 TEL: 886-2-8601-3788 / FAX : 886-2-8601-3789
 E-Mail : service@quietek.com

FCC Accreditation Number: TW1014

2. Conducted Emission

2.1. Test Equipment

	Equipment	Manufacturer	Model No. / Serial No.	Last Cal.	Remark
X	Test Receiver	R & S	ESCS 30 / 825442/018	Sep., 2014	
X	Artificial Mains Network	R & S	ENV4200 / 848411/10	Feb., 2015	Peripherals
X	LISN	R & S	ESH3-Z5 / 825562/002	Feb., 2015	EUT
	DC LISN	Schwarzbeck	8226 / 176	Mar, 2015	EUT
X	Pulse Limiter	R & S	ESH3-Z2 / 357.8810.52	Feb., 2015	
	No.1 Shielded Room				

Note:

1. All equipments are calibrated every one year.
2. The test instruments marked by “X” are used to measure the final test results.

2.2. Test Setup

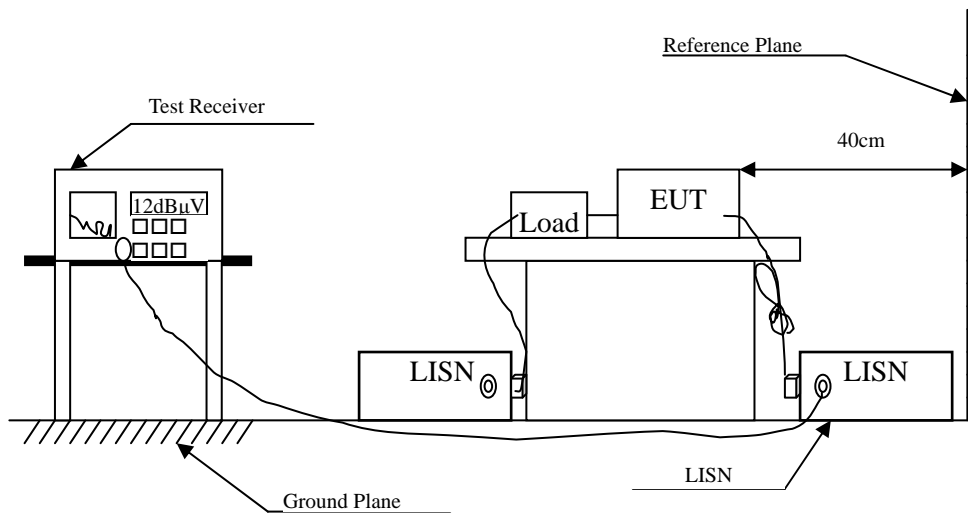

2.3. Limits

FCC Part 15 Subpart C Paragraph 15.207 (dBµV) Limit		
Frequency MHz	Limits	
	QP	AV
0.15 - 0.50	66-56	56-46
0.50-5.0	56	46
5.0 - 30	60	50

Remarks: In the above table, the tighter limit applies at the band edges.

2.4. Test Procedure

The EUT and Peripherals are connected to the main power through a line impedance stabilization network (L.I.S.N.). This provides a 50 ohm /50uH coupling impedance for the measuring equipment. The peripheral devices are also connected to the main power through a LISN that provides a 50ohm /50uH coupling impedance with 50ohm termination. (Please refer to the block diagram of the test setup and photographs.)

Both sides of A.C. line are checked for maximum conducted interference. In order to find the maximum emission, the relative positions of equipment and all the interface cables must be changed according to ANSI C63.4: 2014 on conducted measurement.

Conducted emissions were investigated over the frequency range from 0.15MHz to 30MHz using a receiver bandwidth of 9kHz.

The EUT was setup to ANSI C63.4, 2014; tested to FHSS test procedure of FCC Public Notice DA 00-705 for compliance to FCC 47CFR 15.247 requirements.

2.5. Uncertainty

± 2.26 dB

2.6. Test Result of Conducted Emission

Product : TABLET PC
 Test Item : Conducted Emission Test
 Power Line : Line 1
 Test Mode : Mode 2: Transmit - 3Mbps (8DPSK) (2441MHz)

Frequency MHz	Correct Factor dB	Reading Level dBµV	Measurement Level dBµV	Margin dB	Limit dBµV
LINE 1					
Quasi-Peak					
0.158	9.668	37.400	47.068	-18.703	65.771
0.216	9.661	29.150	38.811	-25.303	64.114
0.857	9.696	13.690	23.386	-32.614	56.000
3.103	9.810	23.020	32.830	-23.170	56.000
12.252	9.981	12.760	22.741	-37.259	60.000
24.002	10.058	26.120	36.178	-23.822	60.000
Average					
0.158	9.668	23.460	33.128	-22.643	55.771
0.216	9.661	16.670	26.331	-27.783	54.114
0.857	9.696	4.050	13.746	-32.254	46.000
3.103	9.810	18.630	28.440	-17.560	46.000
12.252	9.981	7.840	17.821	-32.179	50.000
24.002	10.058	23.570	33.628	-16.372	50.000

Note:

1. All Reading Levels are Quasi-Peak and average value.
2. "█" means the worst emission level.
3. Measurement Level = Reading Level + Correct Factor

Product : TABLET PC
 Test Item : Conducted Emission Test
 Power Line : Line 2
 Test Mode : Mode 2: Transmit - 3Mbps (8DPSK) (2441MHz)

Frequency MHz	Correct Factor dB	Reading Level dBμV	Measurement Level dBμV	Margin dB	Limit dBμV
LINE 2					
Quasi-Peak					
0.166	9.667	37.920	47.586	-17.957	65.543
0.267	9.664	22.850	32.514	-30.143	62.657
0.783	9.692	16.270	25.962	-30.038	56.000
2.904	9.796	23.200	32.996	-23.004	56.000
18.951	10.182	17.380	27.562	-32.438	60.000
24.002	10.238	25.720	35.958	-24.042	60.000
Average					
0.166	9.667	27.630	37.296	-18.247	55.543
0.267	9.664	11.860	21.524	-31.133	52.657
0.783	9.692	4.620	14.312	-31.688	46.000
2.904	9.796	13.070	22.866	-23.134	46.000
18.951	10.182	13.180	23.362	-26.638	50.000
24.002	10.238	23.330	33.568	-16.432	50.000

Note:

1. All Reading Levels are Quasi-Peak and average value.
2. "■" means the worst emission level.
3. Measurement Level = Reading Level + Correct Factor

3. Peak Power Output

3.1. Test Equipment

	Equipment	Manufacturer	Model No./Serial No.	Last Cal.
X	Power Meter	Anritsu	ML2495A/6K00003357	May, 2015
X	Power Sensor	Anritsu	MA2411B/0738448	Jun, 2015

Note: 1. All equipments are calibrated every one year.
2. The test instruments marked by “X” are used to measure the final test results.

3.2. Test Setup

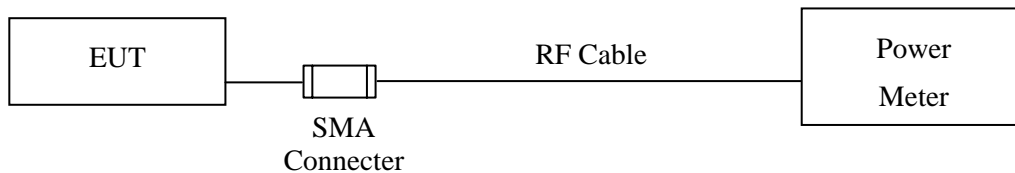

3.3. Limit

The maximum peak power shall be less 1Watt.

3.4. Test Procedure

The EUT was setup to ANSI C63.4, 2014; tested to FHSS test procedure of FCC Public Notice DA 00-705 for compliance to FCC 47CFR 15.247 requirements.

3.5. Uncertainty

± 1.27 dB

3.6. Test Result of Peak Power Output

Product : TABLET PC
Test Item : Peak Power Output
Test Site : No.3 OATS
Test Mode : Mode 1: Transmit - 1Mbps (GFSK)

Channel No.	Frequency (MHz)	Measurement (dBm)	Required Limit	Result
Channel 00	2402.00	-1.79	1 Watt= 30 dBm	Pass
Channel 39	2441.00	-1.61	1 Watt= 30 dBm	Pass
Channel 78	2480.00	-1.38	1 Watt= 30 dBm	Pass

Product : TABLET PC
Test Item : Peak Power Output
Test Site : No.3 OATS
Test Mode : Mode 2: Transmit - 3Mbps (8DPSK)

Channel No.	Frequency (MHz)	Measurement (dBm)	Required Limit	Result
Channel 00	2402.00	-3.31	1 Watt= 30 dBm	Pass
Channel 39	2441.00	-3.13	1 Watt= 30 dBm	Pass
Channel 78	2480.00	-2.92	1 Watt= 30 dBm	Pass

4. Radiated Emission

4.1. Test Equipment

The following test equipments are used during the radiated emission test:

Test Site	Equipment	Manufacturer	Model No./Serial No.	Last Cal.
Site # 3	X Magnetic Loop Antenna	Teseq	HLA6121/ 37133	Sep, 2014
	X Bilog Antenna	Schaffner Chase	CBL6112B/ 2707	Jun, 2015
	X EMI Test Receiver	R&S	ESCS 30/838251/ 001	Jun, 2015
	X Coaxial Cable	QTK(Arnist)	RG 214/ LC003-RG	Jun, 2015
	X Coaxial signal switch	Arnist	MP59B/ 6200798682	Jun, 2015

Test Site	Equipment	Manufacturer	Model No./Serial No.	Last Cal.
CB # 8	X Spectrum Analyzer	R&S	FSP40/ 100339	Oct, 2014
	X Horn Antenna	ETS-Lindgren	3117/ 35205	Mar, 2015
	X Horn Antenna	Schwarzbeck	BBHA9170/209	Jan, 2015
	X Horn Antenna	TRC	AH-0801/95051	Aug, 2014
	X Pre-Amplifier	EMCI	EMC012630SE/980210	Jan, 2015
	X Pre-Amplifier	MITEQ	JS41-001040000-58-5P/153945	Jul, 2015
	X Pre-Amplifier	NARDA	DBL-1840N506/013	Jul, 2015

- Note: 1. All equipments are calibrated with traceable calibrations. Each calibration is traceable to the national or international standards.
2. The test instruments marked with "X" are used to measure the final test results.

4.2. Test Setup

Below 1GHz

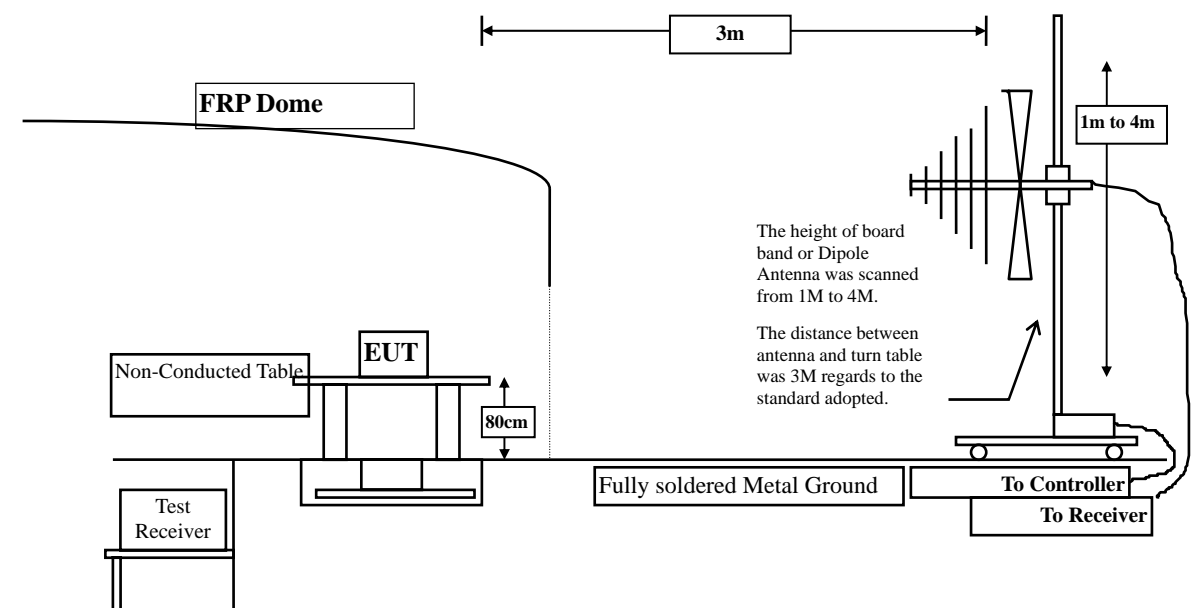

Above 1GHz

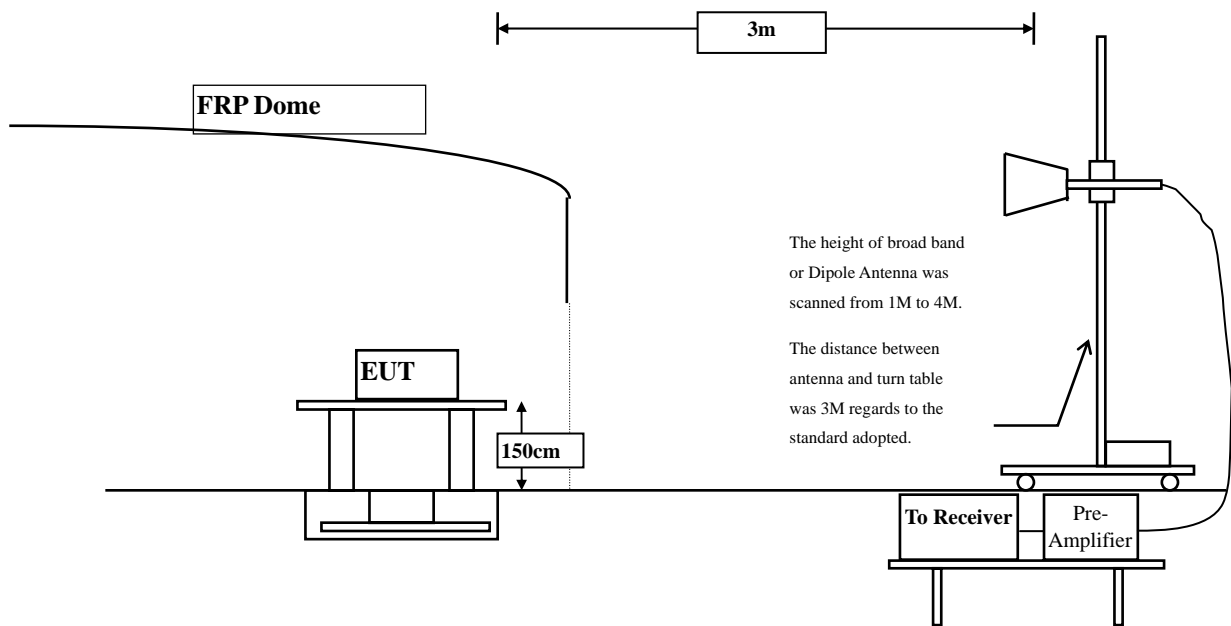

4.3. Limits

➤ General Radiated Emission Limits

Emissions radiated outside of the specified frequency bands, except for harmonics, shall be attenuated by at least 20dB below the level of the fundamental or to the general radiated emission limits in paragraph 15.209, whichever is the lesser attenuation.

FCC Part 15 Subpart C Paragraph 15.209 Limits		
Frequency MHz	uV/m @3m	dBμV/m@3m
30-88	100	40
88-216	150	43.5
216-960	200	46
Above 960	500	54

- Remarks:
1. RF Voltage (dBμV) = 20 log RF Voltage (uV)
 2. In the Above Table, the tighter limit applies at the band edges.
 3. Distance refers to the distance in meters between the measuring instrument antenna and the closed point of any part of the device or system.

4.4. Test Procedure

The EUT was setup according to ANSI C63.10, 2013 and tested compliance to FCC 47CFR 15.249 requirements.

Measuring the frequency range below 1GHz, the EUT is placed on a turn table which is 0.8 meter above ground, when measuring the frequency range above 1GHz, the EUT is placed on a turn table which is 1.5 meter above ground.

The turn table is rotated 360 degrees to determine the position of the maximum emission level.

The EUT was positioned such that the distance from antenna to the EUT was 3 meters.

The antenna is scanned between 1 meter and 4 meters to find out the maximum emission level. This is repeated for both horizontal and vertical polarization of the antenna. In order to find the maximum emission, all of the interface cables were manipulated according to ANSI C63.10: 2013 on radiated measurement.

The resolution bandwidth below 30MHz setting on the field strength meter is 9kHz and 30MHz~1GHz is 120kHz and above 1GHz is 1MHz.

Radiated emission measurements below 30MHz are made using Loop Antenna and 30MHz~1GHz are made using broadband Bilog antenna and above 1GHz are made using Horn Antennas.

The measurement is divided into the Preliminary Measurement and the Final Measurement.

The suspected frequencies are searched for in Preliminary Measurement with the measurement antenna kept pointed at the source of the emission both in azimuth and elevation, with the polarization of the antenna oriented for maximum response. The antenna is pointed at an angle towards the source of the emission, and the EUT is rotated in both height and polarization to maximize the measured emission. The emission is kept within the illumination area of the 3 dB bandwidth of the antenna.

The worst radiated emission is measured in the Open Area Test Site on the Final Measurement.

The measurement frequency range from 9kHz - 10th Harmonic of fundamental was investigated.

4.5. Uncertainty

± 3.9 dB above 1GHz

± 3.8 dB below 1GHz

4.6. Test Result of Radiated Emission

Product : TABLET PC
 Test Item : Harmonic Radiated Emission
 Test Site : No.3 OATS
 Test Mode : Mode 1: Transmit - 1Mbps (GFSK)(2402MHz)

Frequency MHz	Correct Factor dB	Reading Level dB μ V	Measurement Level dB μ V/m	Margin dB	Limit dB μ V/m
Horizontal					
Peak Detector:					
4804.000	3.327	36.020	39.347	-34.653	74.000
7206.000	10.136	33.810	43.946	-30.054	74.000
9608.000	13.706	34.650	48.356	-25.644	74.000
Average Detector:					
--					
Vertical					
Peak Detector:					
4804.000	6.638	35.645	42.282	-31.718	74.000
7206.000	11.005	33.530	44.535	-29.465	74.000
9608.000	14.103	33.250	47.353	-26.647	74.000
Average Detector:					
--					

Note:

1. All Readings below 1GHz are Quasi-Peak, above 1GHz are performed with peak and/or average measurements as necessary.
2. Peak measurements: RBW = 1MHz, VBW = 3 MHz, Sweep: Auto.
3. Average measurements: RBW = 1MHz, VBW = 10 Hz, Sweep: Auto.
4. Measurement Level = Reading Level + Correct Factor.
5. Correct Factor = Antenna factor + Cable loss – Amplifier gain.
6. The average measurement was not performed when the peak measured data under the limit of average detection.
7. The emission levels of other frequencies are very lower than the limit and not show in test report.

Product : TABLET PC
 Test Item : Harmonic Radiated Emission
 Test Site : No.3 OATS
 Test Mode : Mode 1: Transmit - 1Mbps (GFSK)(2441MHz)

Frequency MHz	Correct Factor dB	Reading Level dB μ V	Measurement Level dB μ V/m	Margin dB	Limit dB μ V/m
Horizontal					
Peak Detector:					
4882.000	3.001	36.130	39.131	-34.869	74.000
7323.000	11.846	32.470	44.317	-29.683	74.000
9764.000	12.563	33.230	45.793	-28.207	74.000
Average Detector:					
--					
Vertical					
Peak Detector:					
4882.000	5.713	35.410	41.124	-32.876	74.000
7323.000	12.727	32.590	45.318	-28.682	74.000
9764.000	13.028	32.950	45.978	-28.022	74.000
Average Detector:					
--					

Note:

1. All Readings below 1GHz are Quasi-Peak, above 1GHz are performed with peak and/or average measurements as necessary.
2. Peak measurements: RBW = 1MHz, VBW = 3 MHz, Sweep: Auto.
3. Average measurements: RBW = 1MHz, VBW = 10 Hz, Sweep: Auto.
4. Measurement Level = Reading Level + Correct Factor.
5. Correct Factor = Antenna factor + Cable loss – Amplifier gain.
6. The average measurement was not performed when the peak measured data under the limit of average detection.
7. The emission levels of other frequencies are very lower than the limit and not show in test report.

Product : TABLET PC
 Test Item : Harmonic Radiated Emission
 Test Site : No.3 OATS
 Test Mode : Mode 1: Transmit - 1Mbps (GFSK)(2480MHz)

Frequency MHz	Correct Factor dB	Reading Level dB μ V	Measurement Level dB μ V/m	Margin dB	Limit dB μ V/m
Horizontal					
Peak Detector:					
4960.000	2.760	35.300	38.060	-35.940	74.000
7440.000	12.567	32.990	45.556	-28.444	74.000
9920.000	13.456	34.410	47.866	-26.134	74.000
Average Detector:					
--					
Vertical					
Peak Detector:					
4960.000	5.557	33.430	38.987	-35.013	74.000
7440.000	13.426	33.310	46.735	-27.265	74.000
9920.000	13.958	33.780	47.738	-26.262	74.000
Average Detector:					
--					

Note:

1. All Readings below 1GHz are Quasi-Peak, above 1GHz are performed with peak and/or average measurements as necessary.
2. Peak measurements: RBW = 1MHz, VBW = 3 MHz, Sweep: Auto.
3. Average measurements: RBW = 1MHz, VBW = 10 Hz, Sweep: Auto.
4. Measurement Level = Reading Level + Correct Factor.
5. Correct Factor = Antenna factor + Cable loss – Amplifier gain.
6. The average measurement was not performed when the peak measured data under the limit of average detection.
7. The emission levels of other frequencies are very lower than the limit and not show in test report.

Product : TABLET PC
 Test Item : Harmonic Radiated Emission
 Test Site : No.3 OATS
 Test Mode : Mode 2: Transmit - 3Mbps (8DPSK)(2402MHz)

Frequency MHz	Correct Factor dB	Reading Level dB μ V	Measurement Level dB μ V/m	Margin dB	Limit dB μ V/m
Horizontal					
Peak Detector:					
4804.000	3.327	34.880	38.207	-35.793	74.000
7206.000	10.136	32.490	42.626	-31.374	74.000
9608.000	13.706	32.280	45.986	-28.014	74.000
Average Detector:					
--					
Vertical					
Peak Detector:					
4804.000	6.638	34.430	41.067	-32.933	74.000
7206.000	11.005	32.280	43.285	-30.715	74.000
9608.000	14.103	32.660	46.763	-27.237	74.000
Average Detector:					
--					

Note:

1. All Readings below 1GHz are Quasi-Peak, above 1GHz are performed with peak and/or average measurements as necessary.
2. Peak measurements: RBW = 1MHz, VBW = 3 MHz, Sweep: Auto.
3. Average measurements: RBW = 1MHz, VBW = 10 Hz, Sweep: Auto.
4. Measurement Level = Reading Level + Correct Factor.
5. Correct Factor = Antenna factor + Cable loss – Amplifier gain.
6. The average measurement was not performed when the peak measured data under the limit of average detection.
7. The emission levels of other frequencies are very lower than the limit and not show in test report.

Product : TABLET PC
 Test Item : Harmonic Radiated Emission
 Test Site : No.3 OATS
 Test Mode : Mode 2: Transmit - 3Mbps (8DPSK) (2441MHz)

Frequency MHz	Correct Factor dB	Reading Level dBμV	Measurement Level dBμV/m	Margin dB	Limit dBμV/m
Horizontal					
Peak Detector:					
4882.000	3.001	35.110	38.111	-35.889	74.000
7323.000	11.846	33.290	45.137	-28.863	74.000
9764.000	12.563	32.970	45.533	-28.467	74.000
Average Detector:					
--					
Vertical					
Peak Detector:					
4882.000	5.713	35.040	40.754	-33.246	74.000
7323.000	12.727	32.250	44.978	-29.022	74.000
9764.000	13.028	33.940	46.968	-27.032	74.000
Average Detector:					
--					

Note:

1. All Readings below 1GHz are Quasi-Peak, above 1GHz are performed with peak and/or average measurements as necessary.
2. Peak measurements: RBW = 1MHz, VBW = 3 MHz, Sweep: Auto.
3. Average measurements: RBW = 1MHz, VBW = 10 Hz, Sweep: Auto.
4. Measurement Level = Reading Level + Correct Factor.
5. Correct Factor = Antenna factor + Cable loss – Amplifier gain.
6. The average measurement was not performed when the peak measured data under the limit of average detection.
7. The emission levels of other frequencies are very lower than the limit and not show in test report.

Product : TABLET PC
 Test Item : Harmonic Radiated Emission
 Test Site : No.3 OATS
 Test Mode : Mode 2: Transmit - 3Mbps (8DPSK) (2480MHz)

Frequency MHz	Correct Factor dB	Reading Level dB μ V	Measurement Level dB μ V/m	Margin dB	Limit dB μ V/m
Horizontal					
Peak Detector:					
4960.000	2.760	33.680	36.440	-37.560	74.000
7440.000	12.567	33.700	46.266	-27.734	74.000
9920.000	13.456	34.290	47.746	-26.254	74.000
Average Detector:					
--					
Vertical					
Peak Detector:					
4960.000	5.557	35.320	40.877	-33.123	74.000
7440.000	13.426	33.550	46.975	-27.025	74.000
9920.000	13.958	33.290	47.248	-26.752	74.000
Average Detector:					
--					

Note:

1. All Readings below 1GHz are Quasi-Peak, above 1GHz are performed with peak and/or average measurements as necessary.
2. Peak measurements: RBW = 1MHz, VBW = 3 MHz, Sweep: Auto.
3. Average measurements: RBW = 1MHz, VBW = 10 Hz, Sweep: Auto.
4. Measurement Level = Reading Level + Correct Factor.
5. Correct Factor = Antenna factor + Cable loss – Amplifier gain.
6. The average measurement was not performed when the peak measured data under the limit of average detection.
7. The emission levels of other frequencies are very lower than the limit and not show in test report.

Product : TABLET PC
 Test Item : General Radiated Emission
 Test Site : No.3 OATS
 Test Mode : Mode 1: Transmit - 1Mbps (GFSK) (2441MHz)

Frequency MHz	Correct Factor dB	Reading Level dB μ V	Measurement Level dB μ V/m	Margin dB	Limit dB μ V/m
Horizontal					
153.710	-10.097	43.086	32.990	-10.510	43.500
263.362	-5.004	31.872	26.867	-19.133	46.000
455.957	-0.437	34.629	34.192	-11.808	46.000
561.391	1.511	33.267	34.778	-11.222	46.000
791.942	5.212	31.548	36.760	-9.240	46.000
978.913	6.770	22.754	29.524	-24.476	54.000
Vertical					
90.449	-3.175	35.132	31.956	-11.544	43.500
342.087	-3.588	41.263	37.675	-8.325	46.000
503.754	-0.852	35.728	34.876	-11.124	46.000
576.855	-5.655	34.384	28.729	-17.271	46.000
758.203	2.777	28.810	31.587	-14.413	46.000
964.855	7.897	23.799	31.697	-22.303	54.000

Note:

1. All Readings below 1GHz are Quasi-Peak, above 1GHz are performed with peak and/or average measurements as necessary.
2. Peak measurements: RBW = 1MHz, VBW = 3 MHz, Sweep: Auto.
3. Average measurements: RBW = 1MHz, VBW = 10 Hz, Sweep: Auto.
4. Measurement Level = Reading Level + Correct Factor.
5. Correct Factor = Antenna factor + Cable loss – Amplifier gain.
6. The average measurement was not performed when the peak measured data under the limit of average detection.
7. The emission levels of other frequencies are very lower than the limit and not show in test report.
8. No emission found between lowest internal used/generated frequency to 30MHz.

Product : TABLET PC
 Test Item : General Radiated Emission
 Test Site : No.3 OATS
 Test Mode : Mode 2: Transmit - 3Mbps (8DPSK) (2441MHz)

Frequency MHz	Correct Factor dB	Reading Level dB μ V	Measurement Level dB μ V/m	Margin dB	Limit dB μ V/m
Horizontal					
98.884	-7.565	38.015	30.451	-13.049	43.500
252.116	-5.573	45.984	40.411	-5.589	46.000
457.362	0.192	35.824	36.016	-9.984	46.000
575.449	2.962	38.442	41.404	-4.596	46.000
791.942	5.212	31.462	36.674	-9.326	46.000
959.232	6.293	23.480	29.774	-16.226	46.000
Vertical					
59.522	-4.046	32.363	28.317	-11.683	40.000
454.551	-5.628	23.768	18.139	-27.861	46.000
503.754	-0.852	36.785	35.933	-10.067	46.000
575.449	-5.622	39.395	33.773	-12.227	46.000
791.942	2.897	28.765	31.662	-14.338	46.000
964.855	7.897	24.323	32.221	-21.779	54.000

Note:

1. All Readings below 1GHz are Quasi-Peak, above 1GHz are performed with peak and/or average measurements as necessary.
2. Peak measurements: RBW = 1MHz, VBW = 3 MHz, Sweep: Auto.
3. Average measurements: RBW = 1MHz, VBW = 10 Hz, Sweep: Auto.
4. Measurement Level = Reading Level + Correct Factor.
5. Correct Factor = Antenna factor + Cable loss – Amplifier gain.
6. The average measurement was not performed when the peak measured data under the limit of average detection.
7. The emission levels of other frequencies are very lower than the limit and not show in test report.
8. No emission found between lowest internal used/generated frequency to 30MHz.

5. RF Antenna Conducted Test

5.1. Test Equipment

	Equipment	Manufacturer	Model No./Serial No.	Last Cal.
	Spectrum Analyzer	R&S	FSP40 / 100170	Jun, 2015
	Spectrum Analyzer	Agilent	E4407B / US39440758	Jun, 2015
X	Spectrum Analyzer	Agilent	N9010A / MY48030495	Apr., 2015

Note: 1. All equipments are calibrated every one year.
2. The test instruments Marked “X” are used to measure the final test results.

5.2. Test Setup

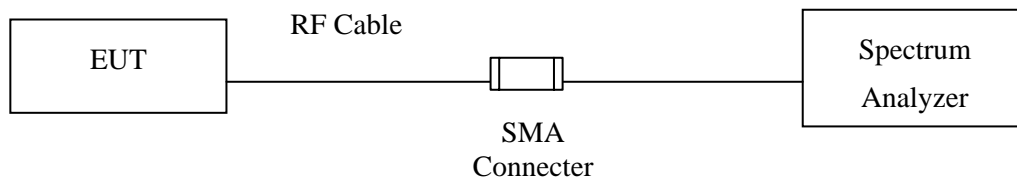

5.3. Limits

According to FCC Section 15.247(d). In any 100 kHz bandwidth outside the frequency band in which the spread spectrum or digitally modulated intentional radiator is operating, the radio frequency power that is produced by the intentional radiator shall be at least 20 dB below that in the 100 kHz bandwidth within the band that contains the highest level of the desired power, based on either an RF conducted or measurement, provided the transmitter demonstrates compliance with the peak conducted power limits. If the transmitter complies with the conducted power limits based on the use of RMS averaging over a time interval, the attenuation required under this paragraph shall be 30 dB instead of 20 dB.

5.4. Test Procedure

The EUT was setup to ANSI C63.4, 2014; tested to FHSS test procedure of FCC Public Notice DA 00-705 for compliance to FCC 47CFR 15.247 requirements.

5.5. Uncertainty

± 150Hz

5.6. Test Result of RF Antenna Conducted Test

Product : TABLET PC
 Test Item : RF Antenna Conducted Test
 Test Site : No.3 OATS
 Test Mode : Mode 1: Transmit - 1Mbps (GFSK)

Figure Channel 00:

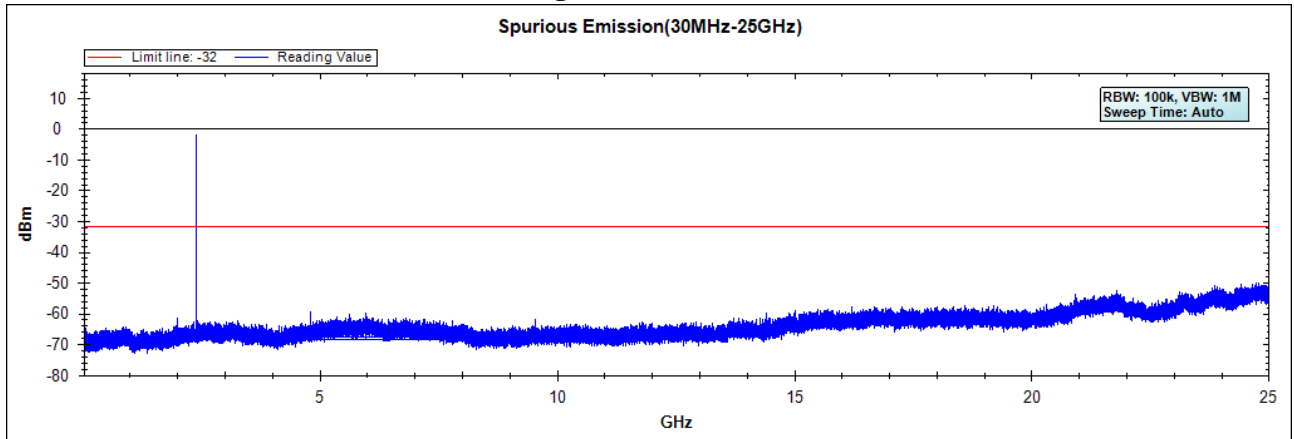

Figure Channel 39:

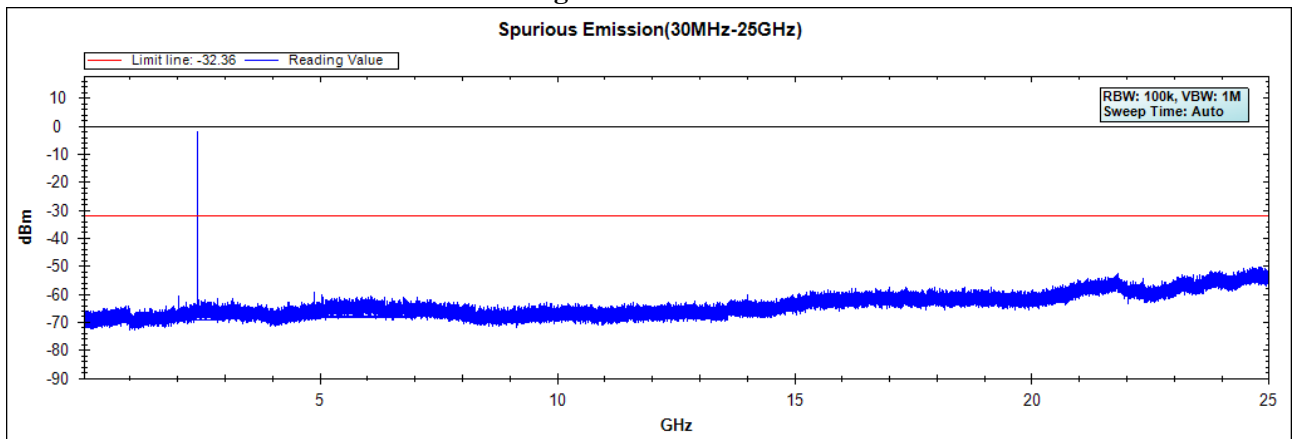
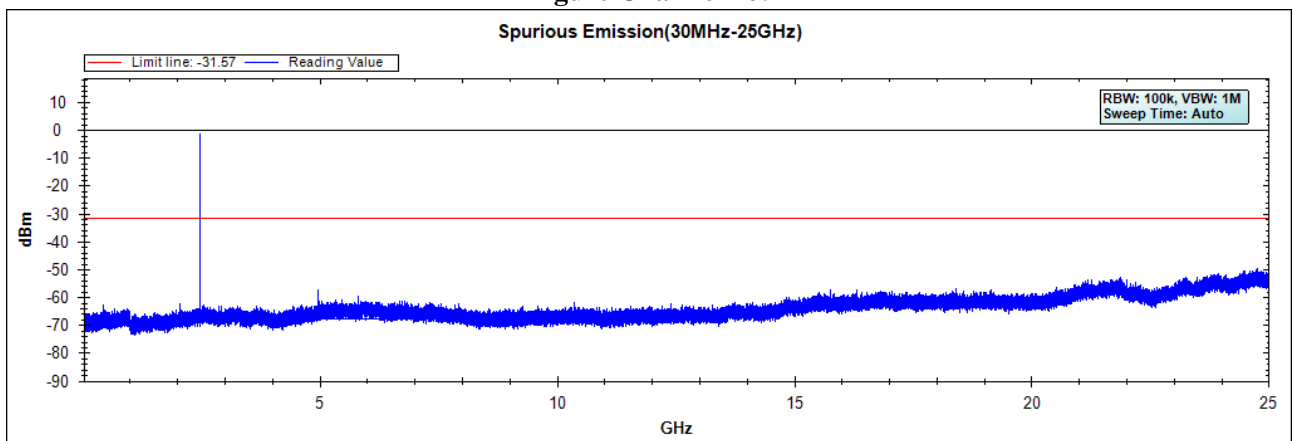

Figure Channel 78:



Note: The above test pattern is synthesized by multiple of the frequency range

Product : TABLET PC
 Test Item : RF Antenna Conducted Test
 Test Site : No.3 OATS
 Test Mode : Mode 2: Transmit - 3Mbps (8DPSK)

Figure Channel 00:

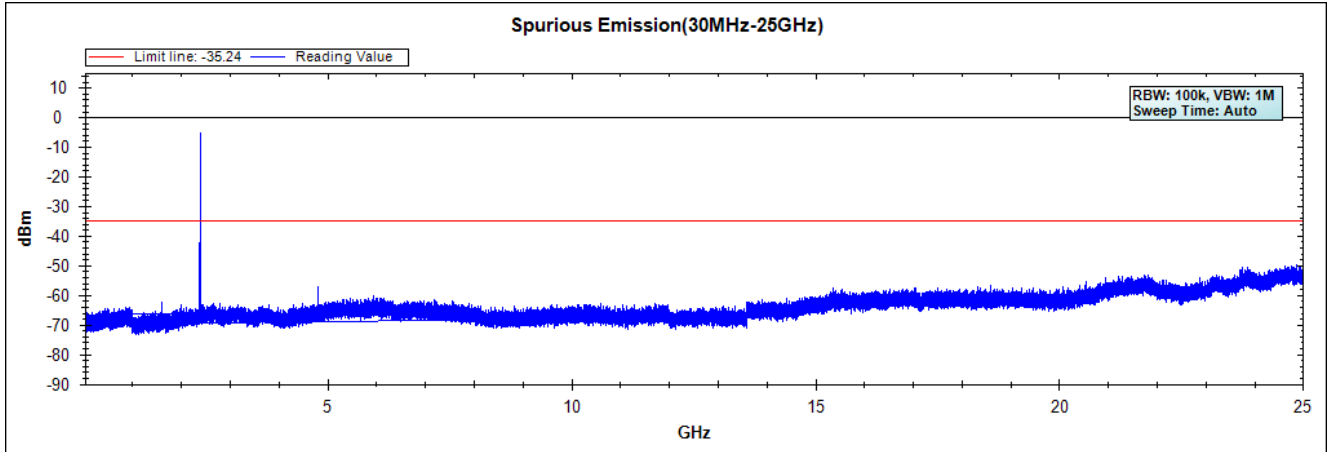

Figure Channel 39:

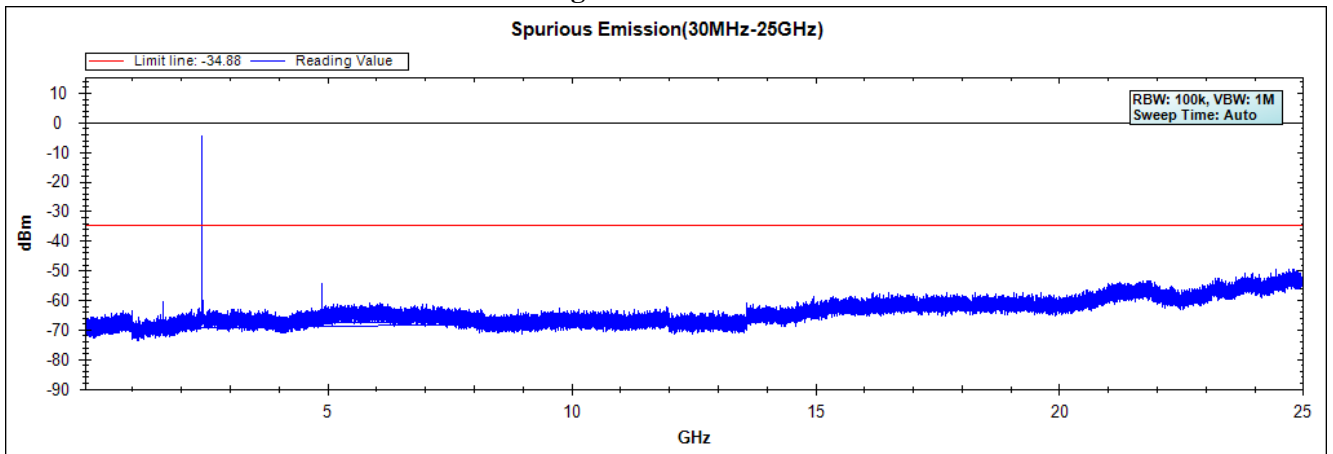
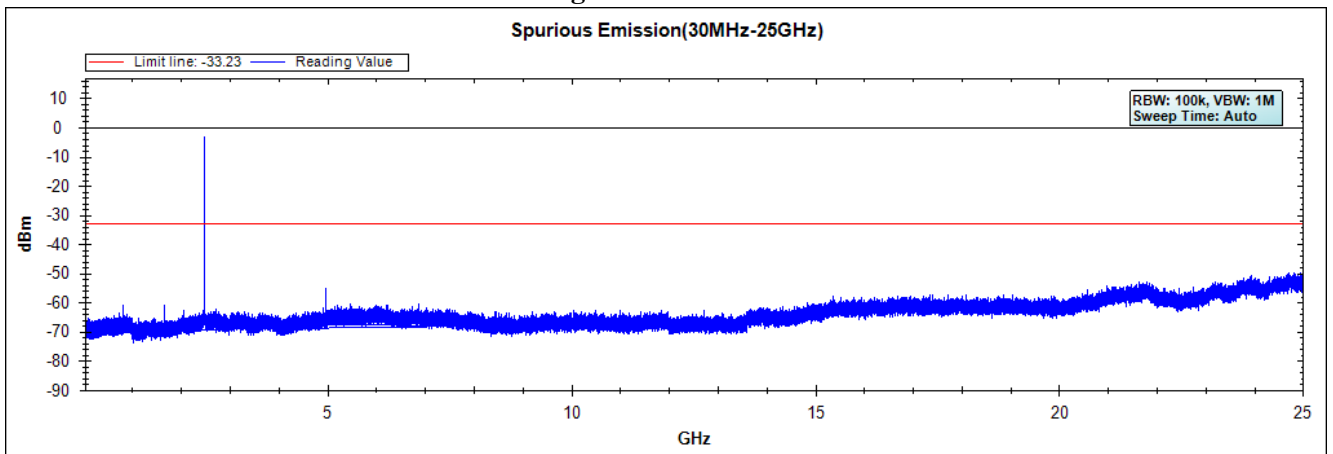

Figure Channel 78:



Note: The above test pattern is synthesized by multiple of the frequency range

6. Band Edge

6.1. Test Equipment

RF Radiated Measurement:

The following test equipments are used during the band edge tests:

Test Site		Equipment	Manufacturer	Model No./Serial No.	Last Cal.
☒ CB # 8	X	Spectrum Analyzer	R&S	FSP40/ 100339	Oct, 2014
	X	Horn Antenna	ETS-Lindgren	3117/ 35205	Mar, 2015
	X	Horn Antenna	Schwarzbeck	BBHA9170/209	Jan, 2015
	X	Horn Antenna	TRC	AH-0801/95051	Aug, 2014
	X	Pre-Amplifier	EMCI	EMC012630SE/980210	Jan, 2015
	X	Pre-Amplifier	MITEQ	JS41-001040000-58-5P/153945	Jul, 2015
	X	Pre-Amplifier	NARDA	DBL-1840N506/013	Jul, 2015

- Note:
1. All equipments are calibrated every one year.
 2. The test instruments marked by "X" are used to measure the final test results.

6.2. Test Setup

RF Radiated Measurement:

Above 1GHz

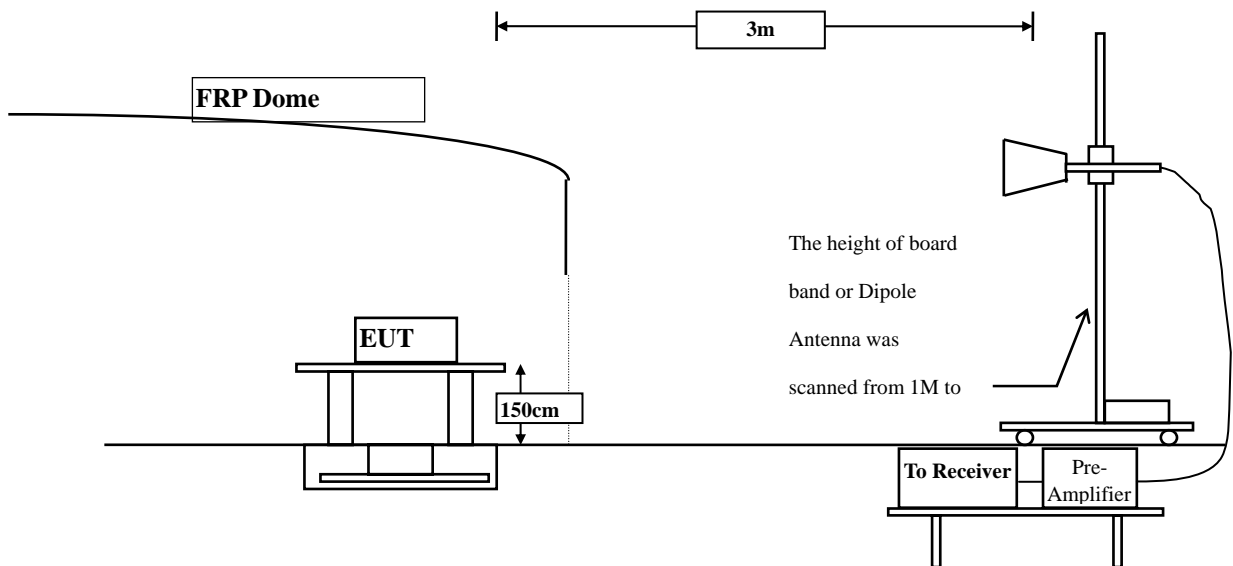

6.3. Limit

In any 100 kHz bandwidth outside the frequency band in which the spread spectrum intentional radiator is operating, the radio frequency power that is produced by the intentional radiator shall be at least 20 dB below that in the 100 kHz bandwidth within the band that contains the highest level of the desired power, based on either an RF conducted or a radiated measurement. Attenuation below the general limits specified in Section 15.209(a) is not required. In addition, radiated emissions which fall in the restricted bands, as defined in Section 15.205(a), must also comply with the radiated emission limits specified in Section 15.209(a) (see Section 15.205(c)).

6.4. Test Procedure

The EUT is placed on a turn table which is 1.5 meter above ground. The turn table is rotated 360 degrees to determine the position of the maximum emission level. The EUT was positioned such that the distance from antenna to the EUT was 3 meters.

The antenna can move up and down between 1 meter and 4 meters to find out the maximum emission level.

Both horizontal and vertical polarization of the antenna are set on measurement. In order to find the maximum emission, all of the interface cables must be manipulated according to ANSI C63.10: 2013 on radiated measurement.

The bandwidth setting below 1GHz and above 1GHz on the field strength meter is 120 kHz and 1MHz, respectively.

6.5. Uncertainty

± 3.9 dB above 1GHz

± 3.8 dB below 1GHz

6.6. Test Result of Band Edge

Product : TABLET PC
 Test Item : Band Edge
 Test Site : No.3 OATS
 Test Mode : Mode 1: Transmit - 1Mbps (GFSK)

RF Radiated Measurement (Horizontal):

Channel No.	Frequency (MHz)	Correct Factor (dB)	Reading Level (dBuV)	Emission Level (dBuV/m)	Peak Limit (dBuV/m)	Average Limit (dBuV/m)	Result
00 (Peak)	2376.812	-1.182	46.091	44.909	74.00	54.00	Pass
00 (Peak)	2390.000	-1.131	36.966	35.835	74.00	54.00	Pass
00 (Peak)	2400.000	-1.084	59.342	58.259	--	--	--
00 (Peak)	2402.174	-1.072	93.033	91.961	--	--	--
00 (Average)	2375.942	-1.186	24.937	23.751	74.00	54.00	Pass
00 (Average)	2390.000	-1.131	23.649	22.518	74.00	54.00	Pass
00 (Average)	2400.000	-1.084	38.028	36.945	--	--	--
00 (Average)	2402.029	-1.073	78.672	77.600	--	--	--

Figure Channel 00: Horizontal (Peak)

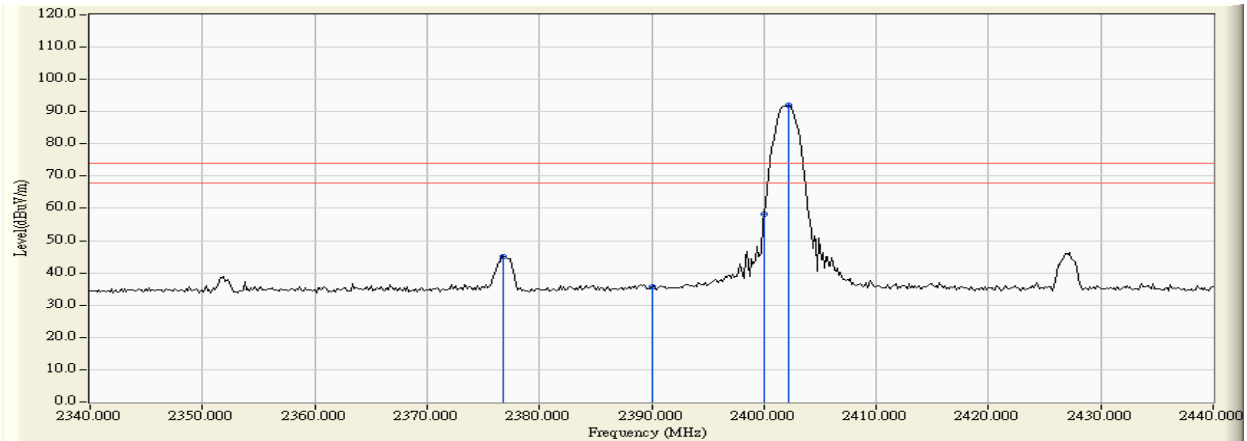
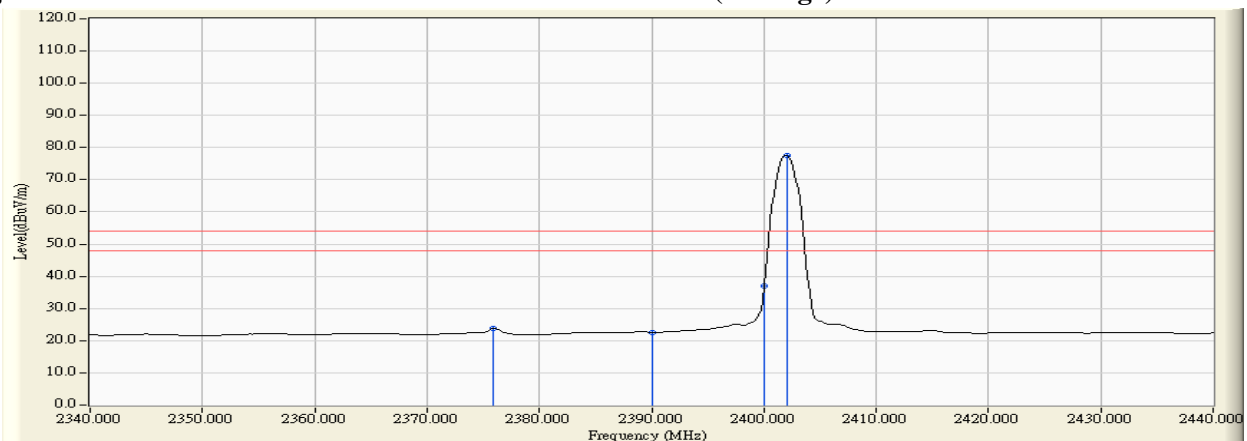

Figure Channel 00: Horizontal (Average)



- Note: 1. All readings above 1GHz are performed with peak and/or average measurements as necessary.
 2. Peak measurements: RBW = 1MHz, VBW = 3 MHz, Sweep: Auto.
 3. Average measurements: RBW = 1MHz, VBW = 10 Hz, Sweep: Auto.
 4. “ * ”, means this data is the worst emission level.
 5. Measurement Level = Reading Level + Correct Factor.
 6. The average measurement was not performed when the peak measured data under the limit of average detection.

Product : TABLET PC
 Test Item : Band Edge
 Test Site : No.3 OATS
 Test Mode : Mode 1: Transmit - 1Mbps (GFSK)

RF Radiated Measurement (Vertical):

Channel No.	Frequency (MHz)	Correct Factor (dB)	Reading Level (dBuV)	Emission Level (dBuV/m)	Peak Limit (dBuV/m)	Average Limit (dBuV/m)	Result
00 (Peak)	2376.522	-1.663	46.414	44.752	74.00	54.00	Pass
00 (Peak)	2390.000	-1.725	36.062	34.337	74.00	54.00	Pass
00 (Peak)	2400.000	-1.733	57.274	55.542	--	--	--
00 (Peak)	2402.174	-1.729	92.868	91.140	--	--	--
00 (Average)	2375.942	-1.660	25.054	23.395	74.00	54.00	Pass
00 (Average)	2390.000	-1.725	23.658	21.933	74.00	54.00	Pass
00 (Average)	2400.000	-1.733	37.572	35.840	--	--	--
00 (Average)	2402.029	-1.729	77.717	75.988	--	--	--

Figure Channel 00: Vertical (Peak)

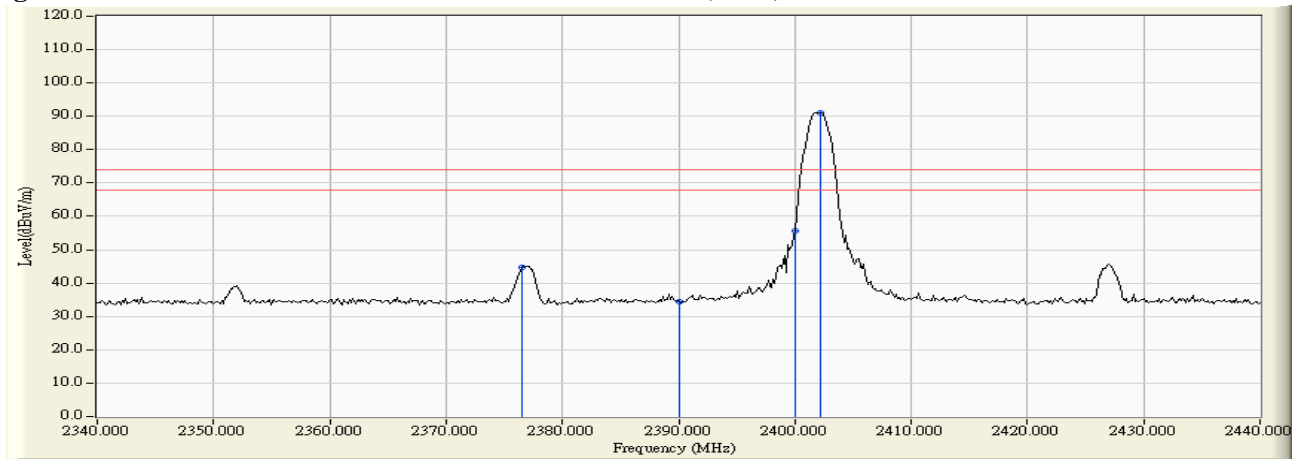
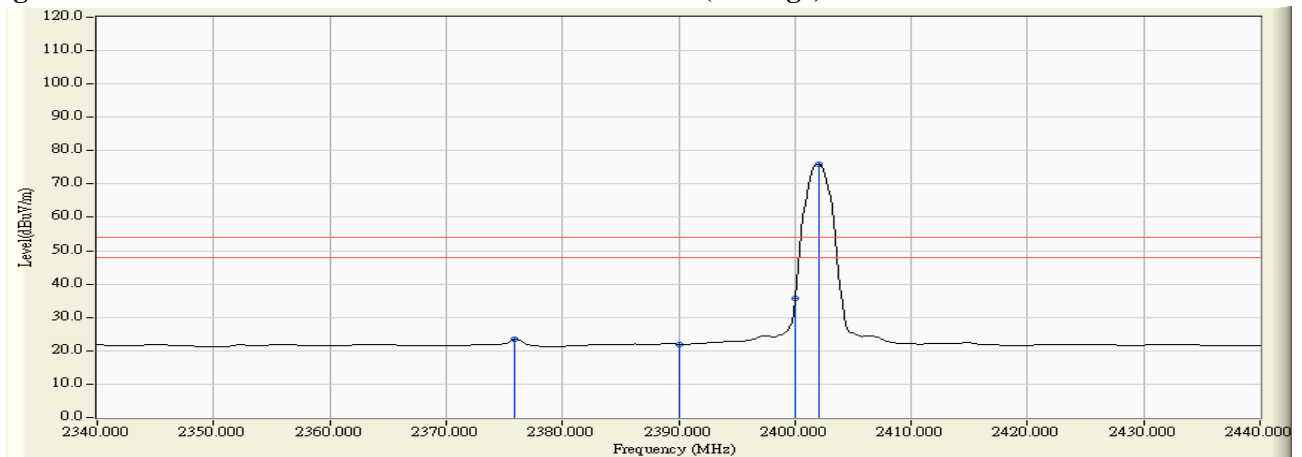

Figure Channel 00: Vertical (Average)



- Note:1. All readings above 1GHz are performed with peak and/or average measurements as necessary.
 2. Peak measurements: RBW = 1MHz, VBW = 3 MHz, Sweep: Auto.
 3. Average measurements: RBW = 1MHz, VBW = 10 Hz, Sweep: Auto.
 4. “ * ”, means this data is the worst emission level.
 5. Measurement Level = Reading Level + Correct Factor.
 6. The average measurement was not performed when the peak measured data under the limit of average detection.

Product : TABLET PC
 Test Item : Band Edge
 Test Site : No.3 OATS
 Test Mode : Mode 1: Transmit - 1Mbps (GFSK)

RF Radiated Measurement (Horizontal):

Channel No.	Frequency (MHz)	Correct Factor (dB)	Reading Level (dBuV)	Emission Level (dBuV/m)	Peak Limit (dBuV/m)	Average Limit (dBuV/m)	Result
78 (Peak)	2480.167	-0.579	92.258	91.679	--	--	--
78 (Peak)	2483.500	-0.558	48.285	47.727	74.00	54.00	Pass
78 (Average)	2480.022	-0.580	77.769	77.189	--	--	--
78 (Average)	2483.500	-0.558	26.242	25.684	74.00	54.00	Pass

Figure Channel 78: Horizontal (Peak)

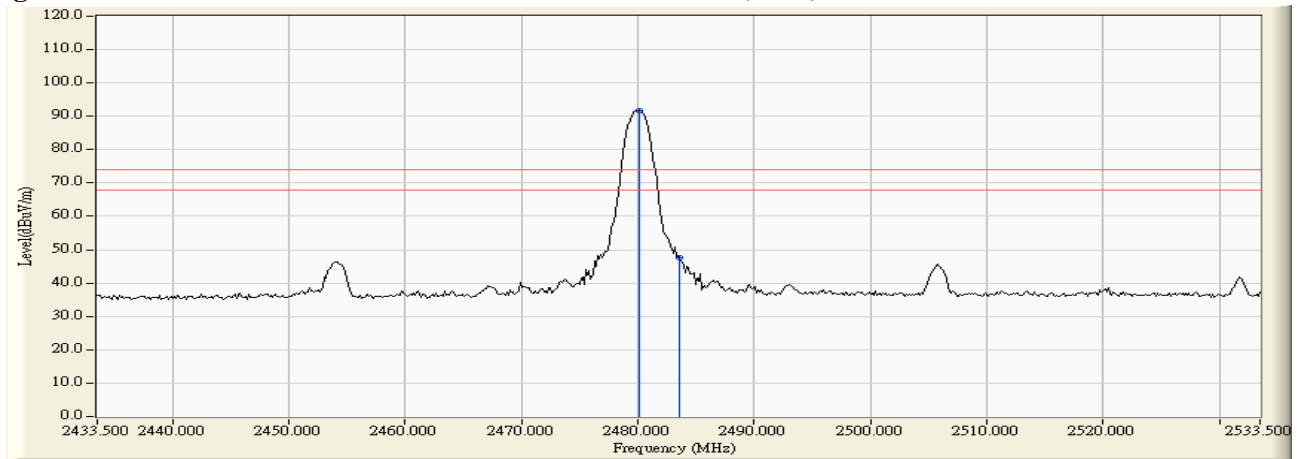
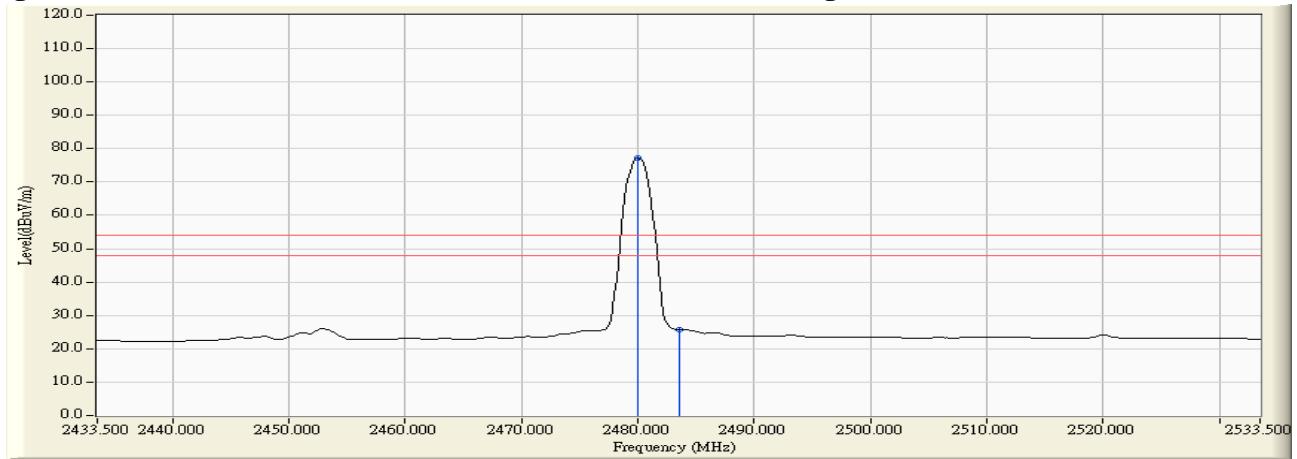

Figure Channel 78: Horizontal (Average)



- Note: 1. All readings above 1GHz are performed with peak and/or average measurements as necessary.
 2. Peak measurements: RBW = 1MHz, VBW = 3 MHz, Sweep: Auto.
 3. Average measurements: RBW = 1MHz, VBW = 10 Hz, Sweep: Auto.
 4. “ * ”, means this data is the worst emission level.
 5. Measurement Level = Reading Level + Correct Factor.
 6. The average measurement was not performed when the peak measured data under the limit of average detection.

Product : TABLET PC
 Test Item : Band Edge
 Test Site : No.3 OATS
 Test Mode : Mode 1: Transmit - 1Mbps (GFSK)

RF Radiated Measurement (Vertical):

Channel No.	Frequency (MHz)	Correct Factor (dB)	Reading Level (dBuV)	Emission Level (dBuV/m)	Peak Limit (dBuV/m)	Average Limit (dBuV/m)	Result
78 (Peak)	2480.022	-1.324	93.922	92.598	--	--	--
78 (Peak)	2483.500	-1.305	46.469	45.164	74.00	54.00	Pass
78 (Peak)	2505.674	-1.228	47.200	45.972	74.00	54.00	Pass
78 (Average)	2480.022	-1.324	78.912	77.588	--	--	--
78 (Average)	2483.500	-1.305	26.547	25.242	74.00	54.00	Pass

Figure Channel 78: Vertical (Peak)

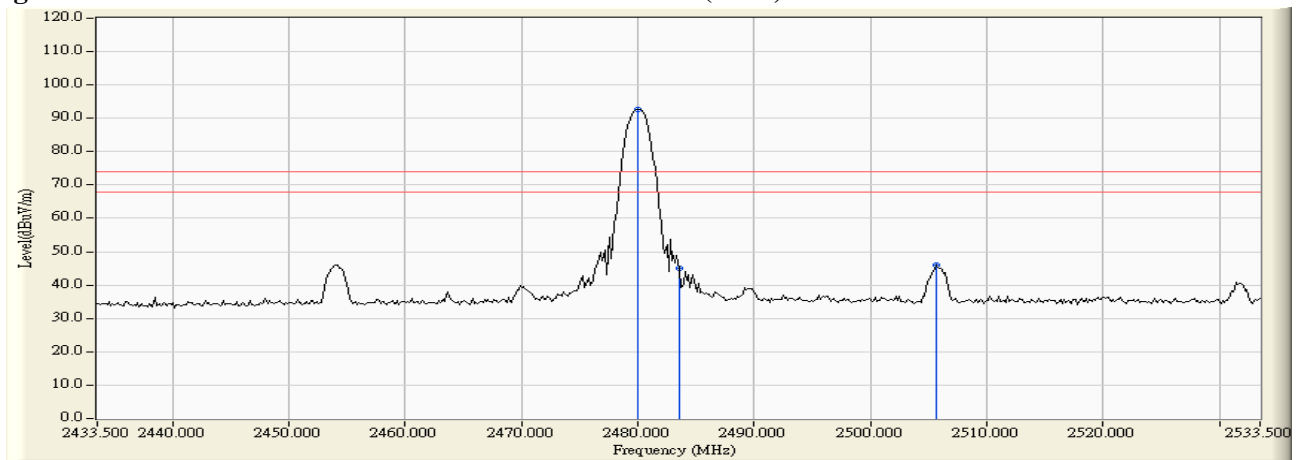
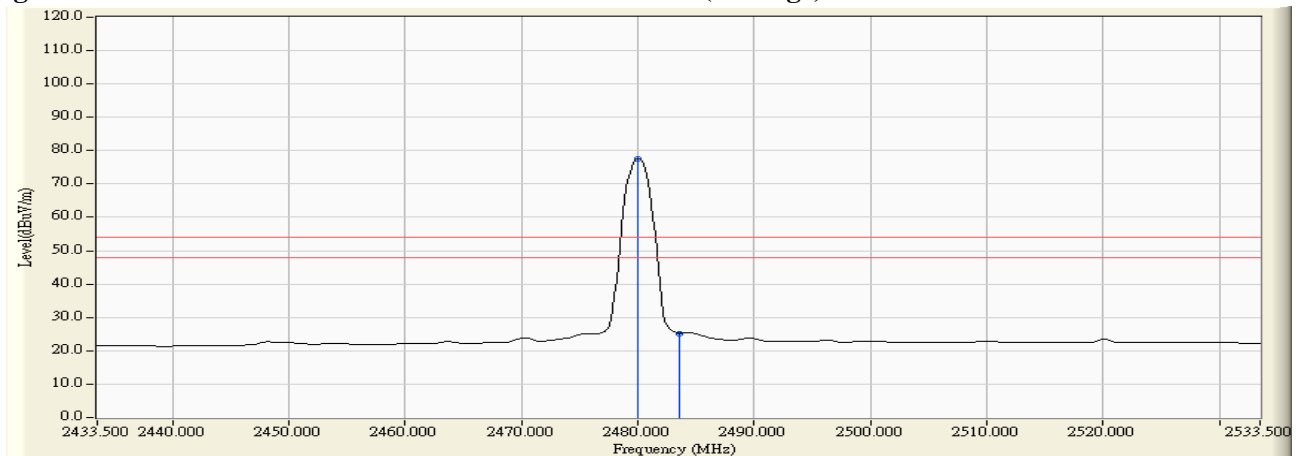

Figure Channel 78: Vertical (Average)



- Note: 1. All readings above 1GHz are performed with peak and/or average measurements as necessary.
 2. Peak measurements: RBW = 1MHz, VBW = 3 MHz, Sweep: Auto.
 3. Average measurements: RBW = 1MHz, VBW = 10 Hz, Sweep: Auto.
 4. “ * ”, means this data is the worst emission level.
 5. Measurement Level = Reading Level + Correct Factor.
 6. The average measurement was not performed when the peak measured data under the limit of average detection.

Product : TABLET PC
 Test Item : Band Edge
 Test Site : No.3 OATS
 Test Mode : Mode 2: Transmit - 3Mbps (8DPSK)

RF Radiated Measurement (Horizontal):

Channel No.	Frequency (MHz)	Correct Factor (dB)	Reading Level (dBuV)	Emission Level (dBuV/m)	Peak Limit (dBuV/m)	Average Limit (dBuV/m)	Result
00 (Peak)	2387.826	-1.139	52.896	51.757	74.00	54.00	Pass
00 (Peak)	2390.000	-1.131	43.098	41.967	74.00	54.00	Pass
00 (Peak)	2400.000	-1.084	63.955	62.872	--	--	--
00 (Peak)	2402.029	-1.073	92.711	91.639	--	--	--
00 (Average)	2390.000	-1.131	24.859	23.728	74.00	54.00	Pass
00 (Average)	2400.000	-1.084	45.164	44.081	--	--	--
00 (Average)	2401.884	-1.073	76.268	75.195	--	--	--

Figure Channel 00: Horizontal (Peak)

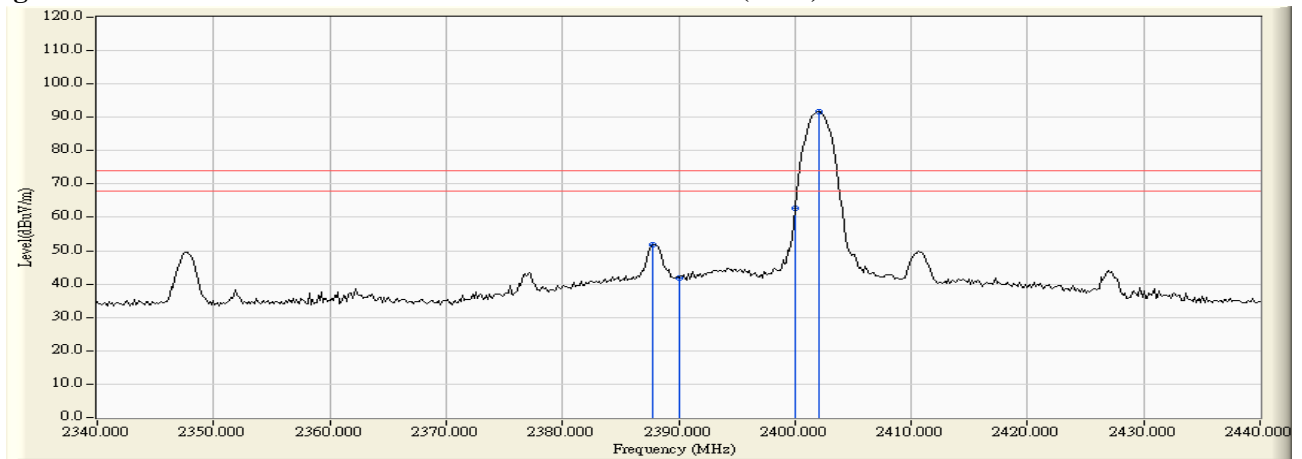
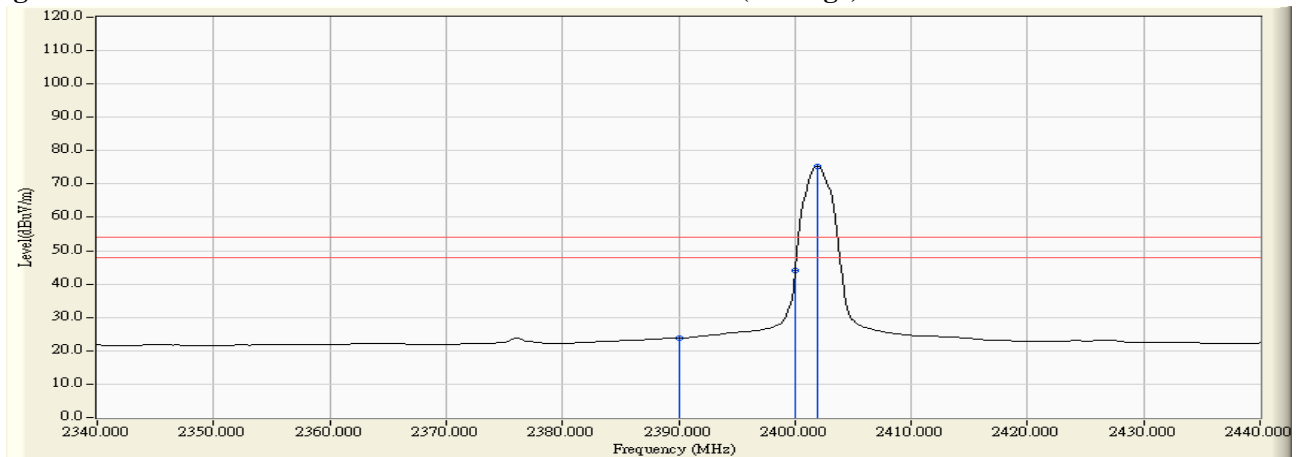

Figure Channel 00: Horizontal (Average)



- Note: 1. All readings above 1GHz are performed with peak and/or average measurements as necessary.
 2. Peak measurements: RBW = 1MHz, VBW = 3 MHz, Sweep: Auto.
 3. Average measurements: RBW = 1MHz, VBW = 10 Hz, Sweep: Auto.
 4. “ * ”, means this data is the worst emission level.
 5. Measurement Level = Reading Level + Correct Factor.
 6. The average measurement was not performed when the peak measured data under the limit of average detection.

Product : TABLET PC
 Test Item : Band Edge
 Test Site : No.3 OATS
 Test Mode : Mode 2: Transmit - 3Mbps (8DPSK)

RF Radiated Measurement (Vertical):

Channel No.	Frequency (MHz)	Correct Factor (dB)	Reading Level (dBuV)	Emission Level (dBuV/m)	Peak Limit (dBuV/m)	Average Limit (dBuV/m)	Result
00 (Peak)	2387.826	-1.715	53.011	51.296	74.00	54.00	Pass
00 (Peak)	2390.000	-1.725	42.741	41.016	74.00	54.00	Pass
00 (Peak)	2400.000	-1.733	64.029	62.297	--	--	--
00 (Peak)	2402.029	-1.729	92.804	91.075	--	--	--
00 (Average)	2376.087	-1.661	25.029	23.369	74.00	54.00	Pass
00 (Average)	2390.000	-1.725	24.930	23.205	74.00	54.00	Pass
00 (Average)	2400.000	-1.733	44.619	42.887	--	--	--
00 (Average)	2401.884	-1.729	75.657	73.928	--	--	--

Figure Channel 00: Vertical (Peak)

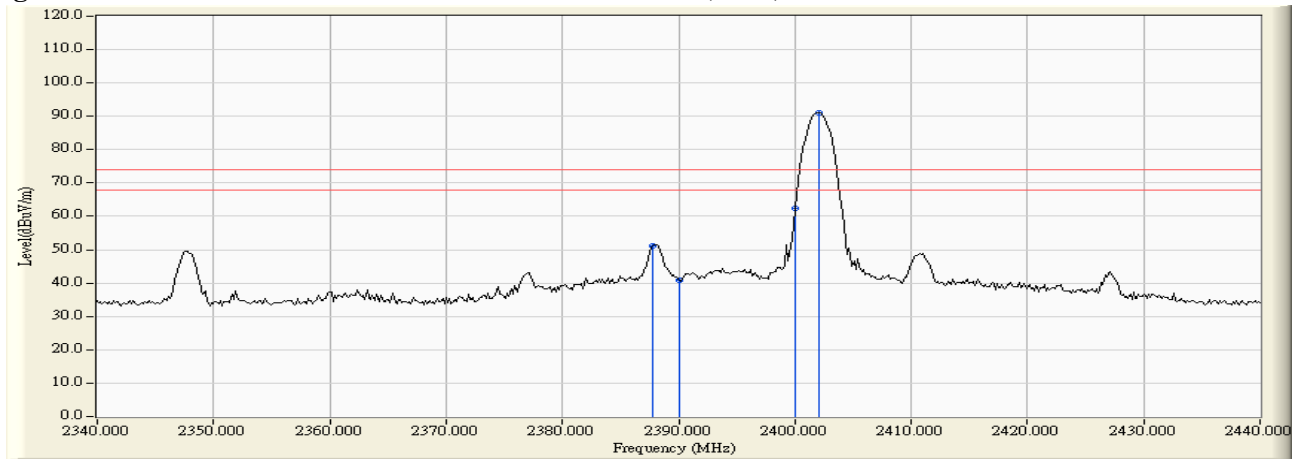
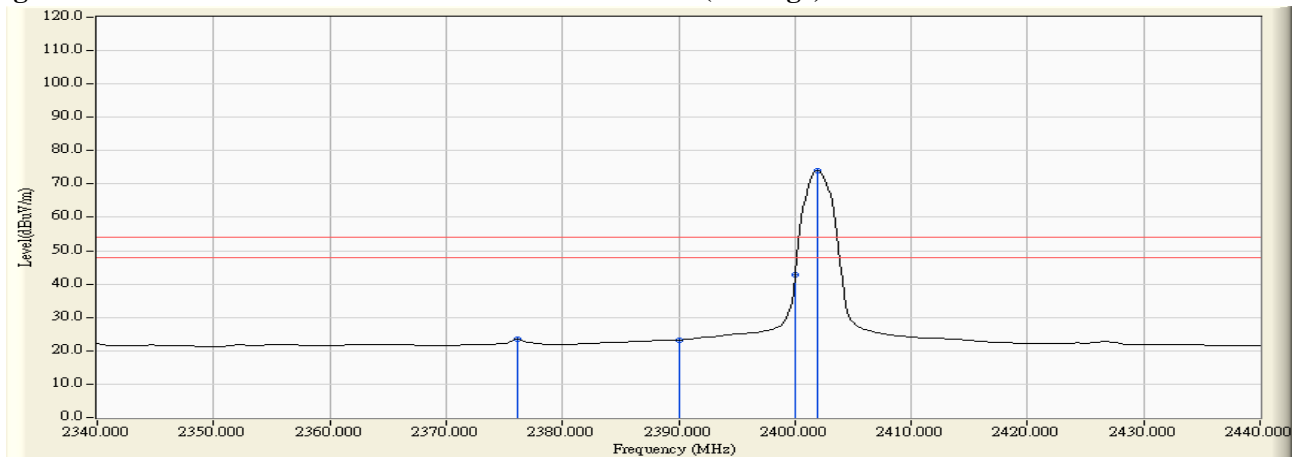

Figure Channel 00: Vertical (Average)



- Note:1. All readings above 1GHz are performed with peak and/or average measurements as necessary.
 2. Peak measurements: RBW = 1MHz, VBW = 3 MHz, Sweep: Auto.
 3. Average measurements: RBW = 1MHz, VBW = 10 Hz, Sweep: Auto.
 4. “ * ”, means this data is the worst emission level.
 5. Measurement Level = Reading Level + Correct Factor.
 6. The average measurement was not performed when the peak measured data under the limit of average detection.

Product : TABLET PC
 Test Item : Band Edge
 Test Site : No.3 OATS
 Test Mode : Mode 2: Transmit - 3Mbps (8DPSK)

RF Radiated Measurement (Horizontal):

Channel No.	Frequency (MHz)	Correct Factor (dB)	Reading Level (dBuV)	Emission Level (dBuV/m)	Peak Limit (dBuV/m)	Average Limit (dBuV/m)	Result
78 (Peak)	2480.022	-0.580	91.808	91.228	--	--	--
78 (Peak)	2483.500	-0.558	44.163	43.605	74.00	54.00	Pass
78 (Peak)	2494.225	-0.490	46.913	46.423	74.00	54.00	Pass
78 (Average)	2480.022	-0.580	75.020	74.440	--	--	--
78 (Average)	2483.500	-0.558	27.980	27.422	74.00	54.00	Pass

Figure Channel 78: Horizontal (Peak)

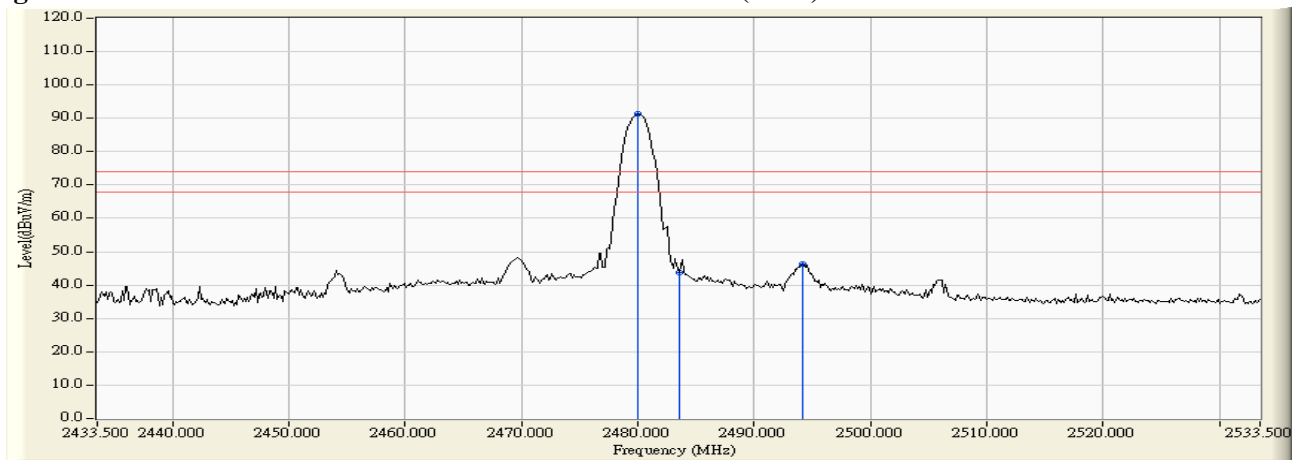
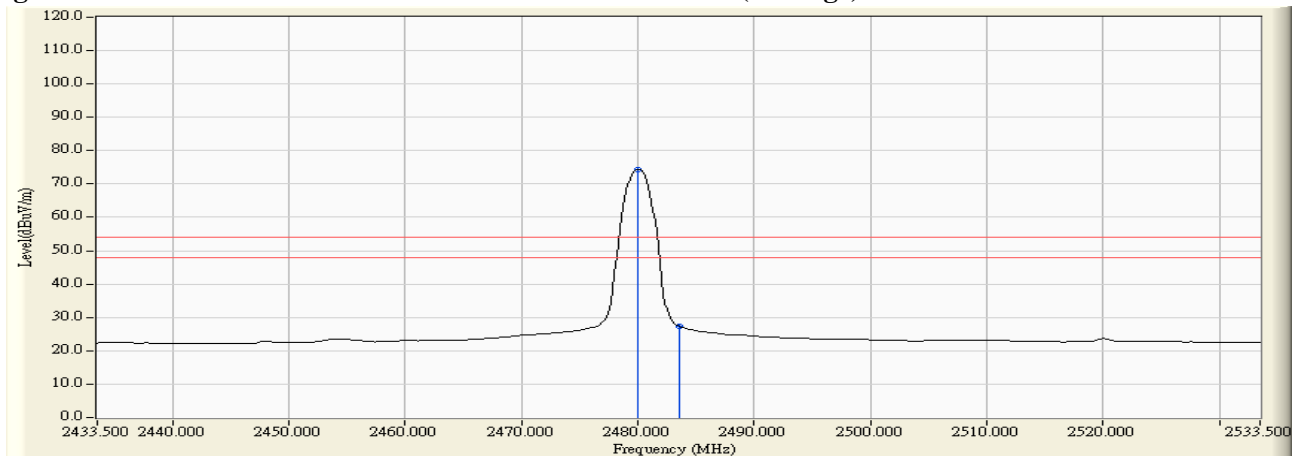

Figure Channel 78: Horizontal (Average)



- Note: 1. All readings above 1GHz are performed with peak and/or average measurements as necessary.
 2. Peak measurements: RBW = 1MHz, VBW = 3 MHz, Sweep: Auto.
 3. Average measurements: RBW = 1MHz, VBW = 10 Hz, Sweep: Auto.
 4. “ * ”, means this data is the worst emission level.
 5. Measurement Level = Reading Level + Correct Factor.
 6. The average measurement was not performed when the peak measured data under the limit of average detection.

Product : TABLET PC
 Test Item : Band Edge
 Test Site : No.3 OATS
 Test Mode : Mode 2: Transmit - 3Mbps (8DPSK)

RF Radiated Measurement (Vertical):

Channel No.	Frequency (MHz)	Correct Factor (dB)	Reading Level (dBuV)	Emission Level (dBuV/m)	Peak Limit (dBuV/m)	Average Limit (dBuV/m)	Result
78 (Peak)	2480.022	-1.324	93.957	92.633	--	--	--
78 (Peak)	2483.500	-1.305	50.107	48.802	74.00	54.00	Pass
78 (Average)	2480.022	-1.324	75.801	74.477	--	--	--
78 (Average)	2483.500	-1.305	29.265	27.960	74.00	54.00	Pass

Figure Channel 78: Vertical (Peak)

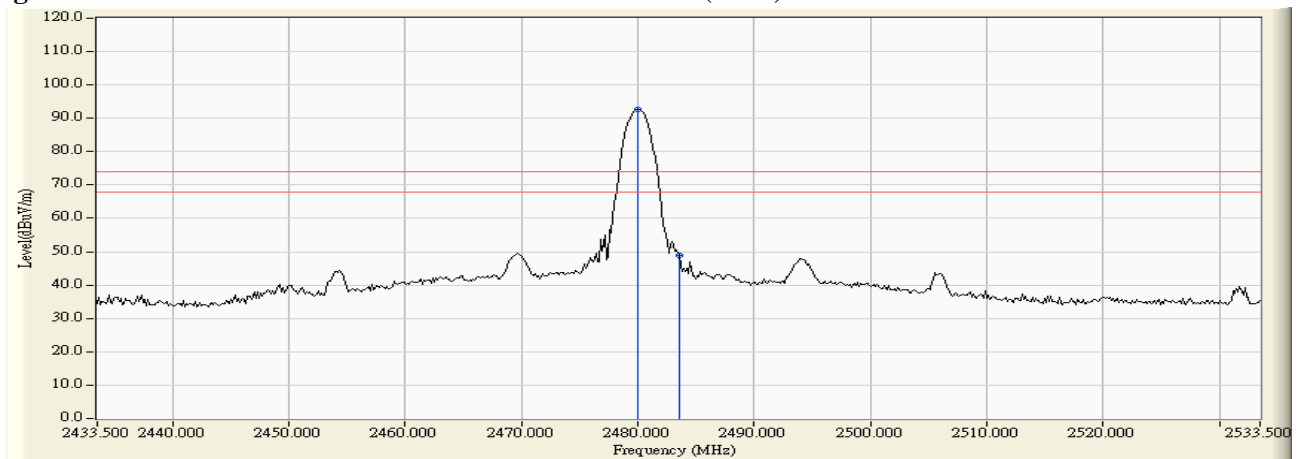
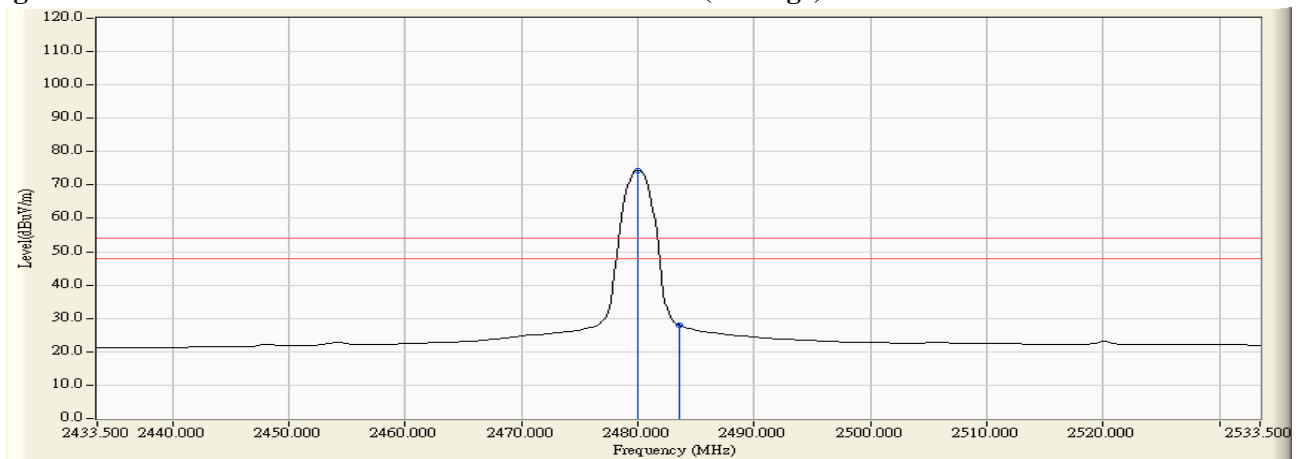

Figure Channel 78: Vertical (Average)



- Note: 1. All readings above 1GHz are performed with peak and/or average measurements as necessary.
 2. Peak measurements: RBW = 1MHz, VBW = 3 MHz, Sweep: Auto.
 3. Average measurements: RBW = 1MHz, VBW = 10 Hz, Sweep: Auto.
 4. “ * ”, means this data is the worst emission level.
 5. Measurement Level = Reading Level + Correct Factor.
 6. The average measurement was not performed when the peak measured data under the limit of average detection.

7. Channel Number

7.1. Test Equipment

	Equipment	Manufacturer	Model No./Serial No.	Last Cal.
	Spectrum Analyzer	R&S	FSP40 / 100170	Jun, 2015
	Spectrum Analyzer	Agilent	E4407B / US39440758	Jun, 2015
X	Spectrum Analyzer	Agilent	N9010A / MY48030495	Apr., 2015

Note: 1. All equipments are calibrated every one year.
2. The test instruments marked by "X" are used to measure the final test results.

7.2. Test Setup

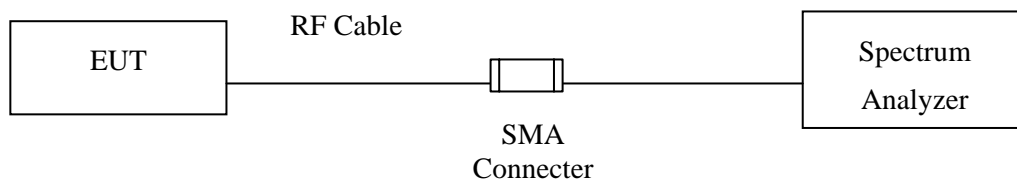

7.3. Limit

Frequency hopping systems operating in the 2400-2483.5 MHz bands shall use at least 75 hopping frequencies.

7.4. Test Procedure

The EUT was setup to ANSI C63.4, 2014; tested to FHSS test procedure of FCC Public Notice DA 00-705 for compliance to FCC 47CFR 15.247 requirements.

7.5. Uncertainty

N/A

7.6. Test Result of Channel Number

Product : TABLET PC
 Test Item : Channel Number
 Test Site : No.3 OATS
 Test Mode : Mode 1: Transmit - 1Mbps (GFSK)

Frequency Range (MHz)	Measurement (Hopping Channel)	Required Limit (Hopping Channel)	Result
2402 ~ 2480	79	>75	Pass

2402-2421MHz

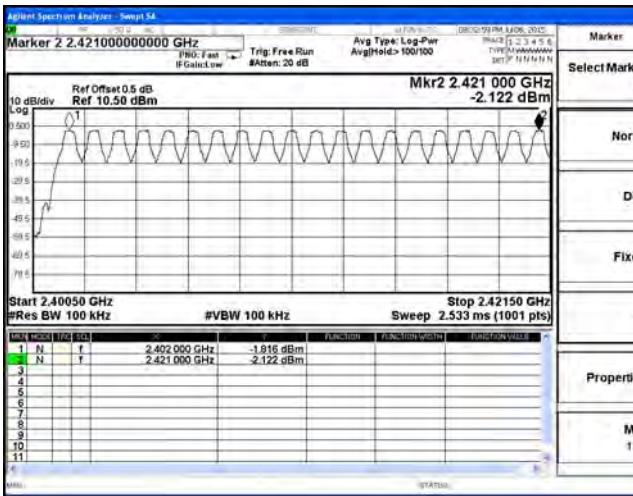

2422-2441MHz

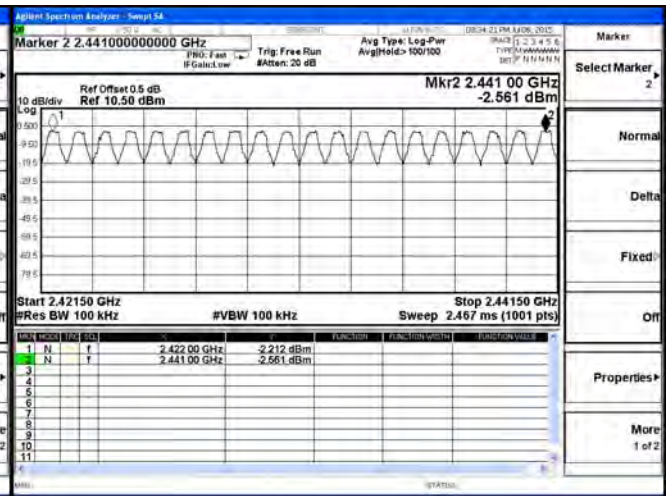

2442-2461MHz

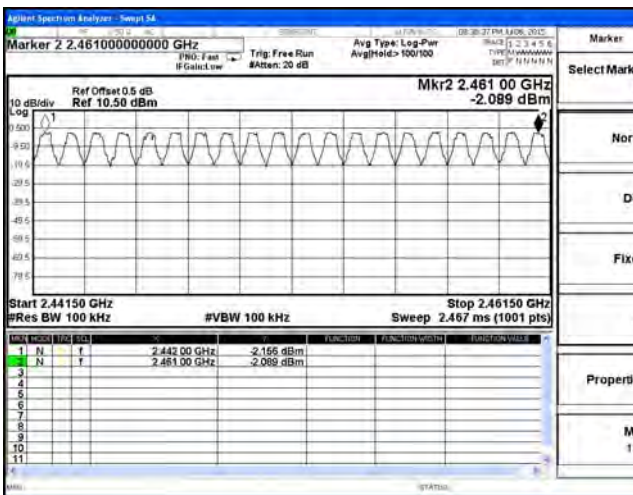

2462-2480MHz

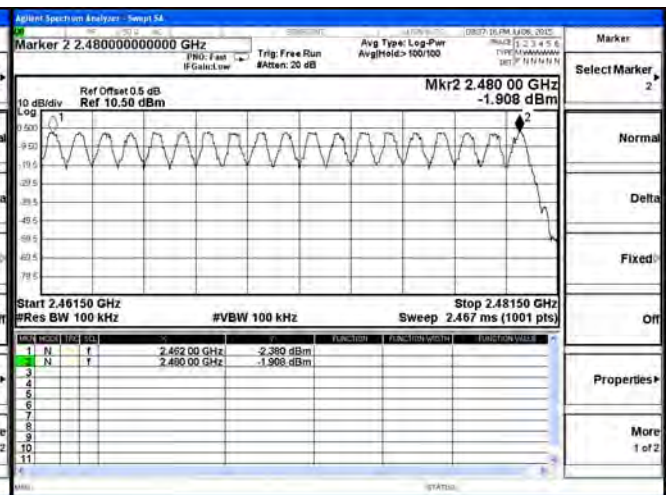

Product : TABLET PC
 Test Item : Channel Number
 Test Site : No.3 OATS
 Test Mode : Mode 2: Transmit - 3Mbps (8DPSK)

Frequency Range (MHz)	Measurement (Hopping Channel)	Required Limit (Hopping Channel)	Result
2402 ~ 2480	79	>75	Pass

2402-2421MHz

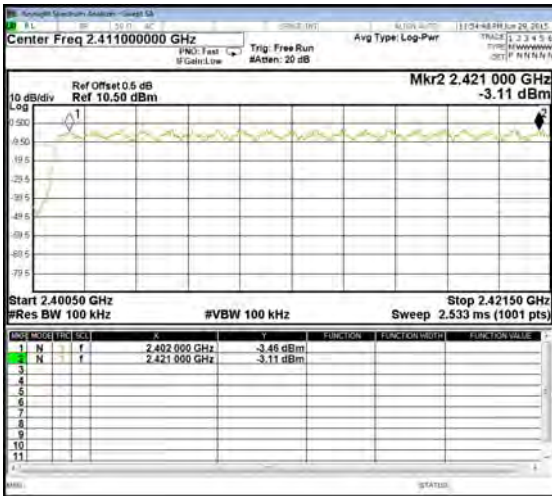

2422-2441MHz

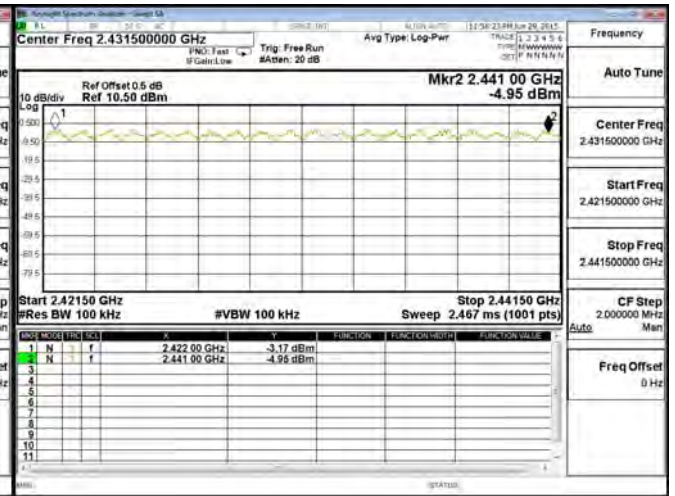

2442-2461MHz

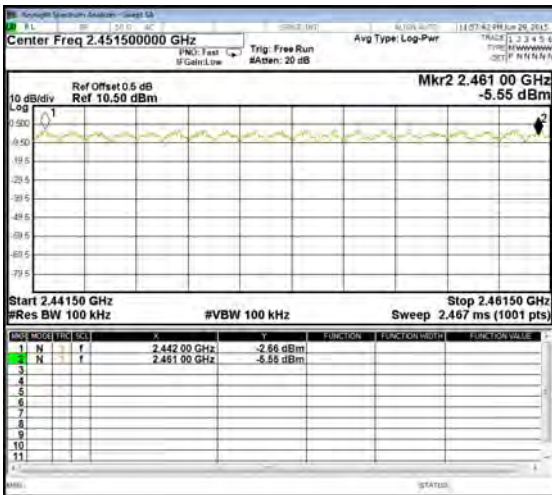

2462-2480MHz

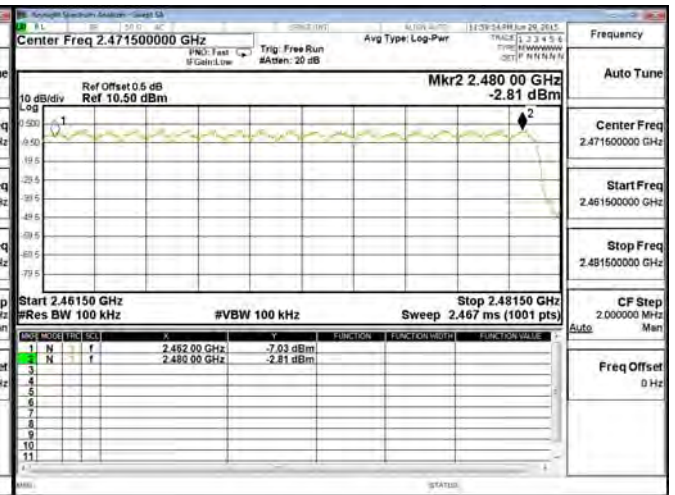

8. Channel Separation

8.1. Test Equipment

	Equipment	Manufacturer	Model No./Serial No.	Last Cal.
	Spectrum Analyzer	R&S	FSP40 / 100170	Jun, 2015
	Spectrum Analyzer	Agilent	E4407B / US39440758	Jun, 2015
X	Spectrum Analyzer	Agilent	N9010A / MY48030495	Apr., 2015

Note: 1. All equipments are calibrated every one year.
2. The test instruments mark by “X” are used to measure the final test results.

8.2. Test Setup

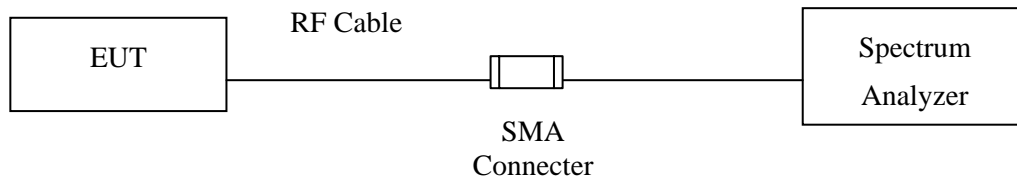

8.3. Limit

Frequency hopping systems shall have hopping channel carrier frequencies separated by a minimum of 25 kHz or the 20 dB bandwidth of the hopping channel, whichever is greater.

8.4. Test Procedure

The EUT was setup to ANSI C63.4, 2014; tested to FHSS test procedure of FCC Public Notice DA 00-705 for compliance to FCC 47CFR 15.247 requirements.

8.5. Uncertainty

± 150Hz

8.6. Test Result of Channel Separation

Product : TABLET PC
 Test Item : Channel Separation
 Test Site : No.3 OATS
 Test Mode : Mode 1: Transmit - 1Mbps (GFSK)

Channel No.	Frequency (MHz)	Measurement Level (kHz)	Limit (kHz)	Limit of (2/3)*20dB Bandwidth (kHz)	Result
00	2402	1000	>25 kHz	740.0	Pass
39	2441	1000	>25 kHz	740.0	Pass
78	2480	1000	>25 kHz	753.3	Pass

NOTE: The 20dB Bandwidth is refer to section 10.

Channel 00 2402MHz

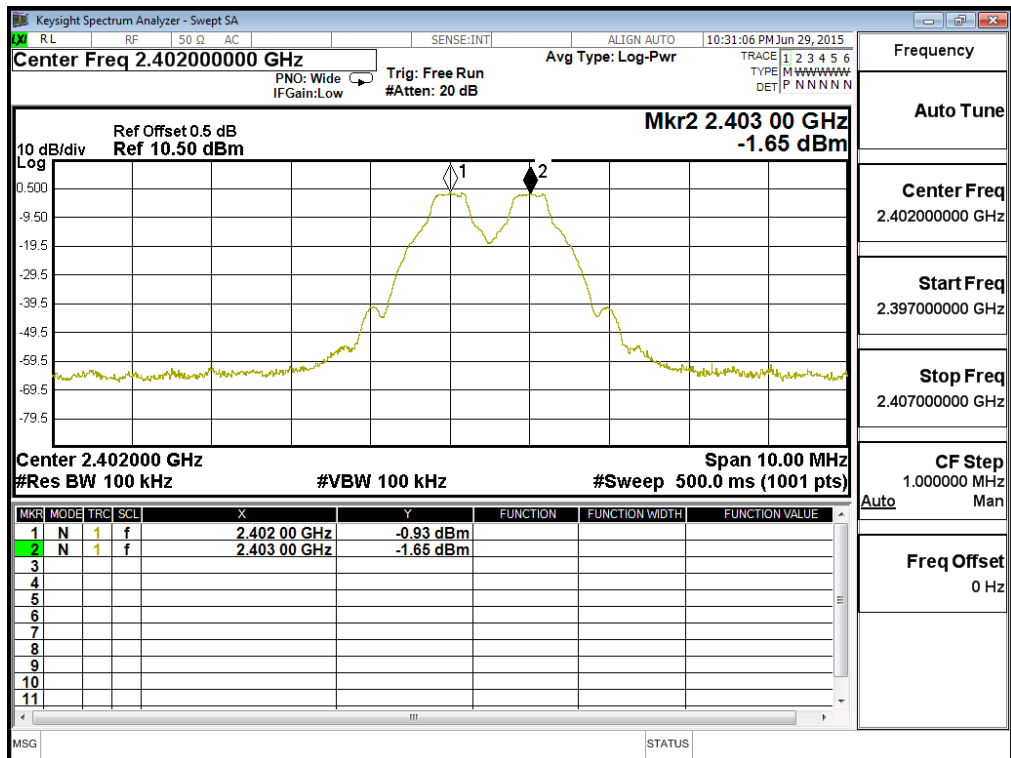

Channel 39 2441MHz

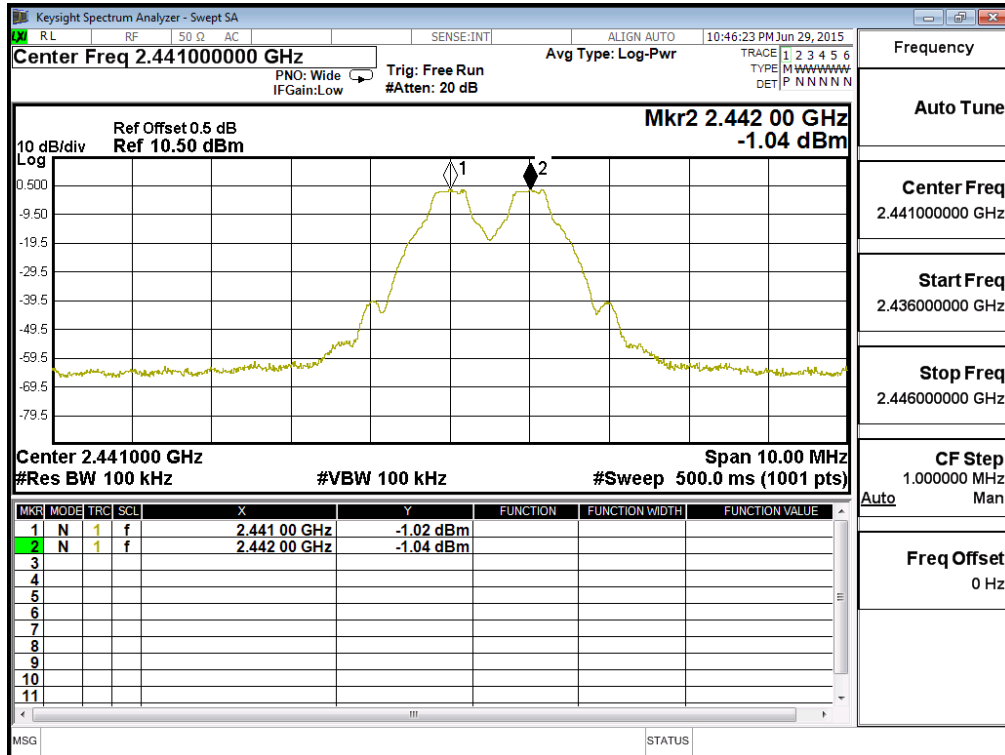

Channel 78 2480 MHz

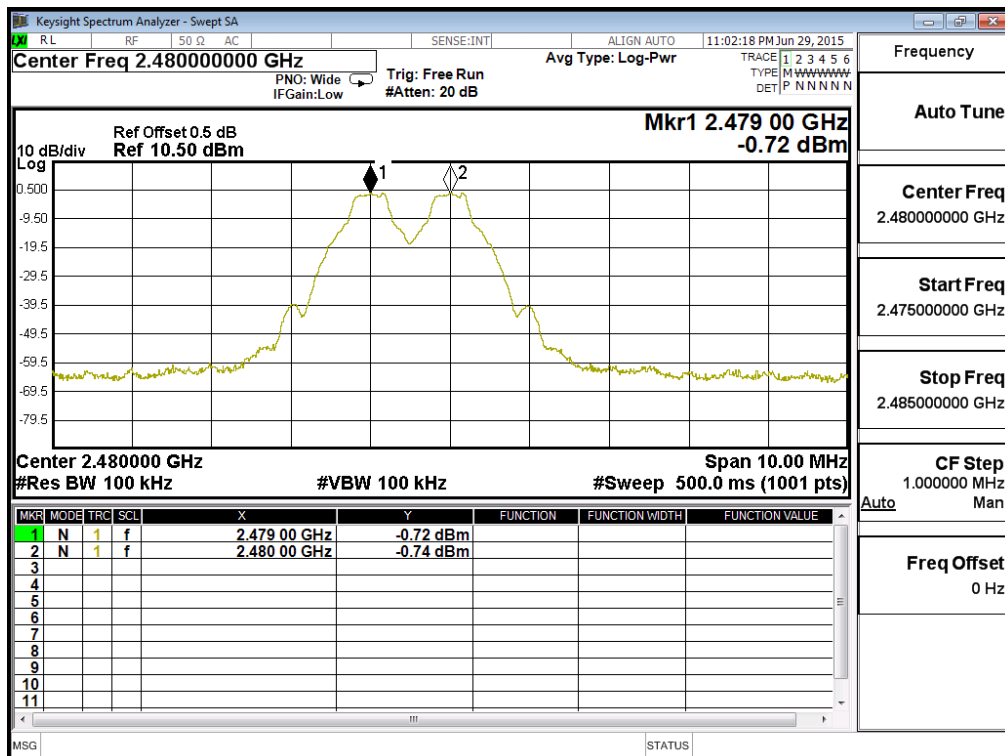

Product : TABLET PC
 Test Item : Channel Separation
 Test Site : No.3 OATS
 Test Mode : Mode 2: Transmit - 3Mbps (8DPSK)

Channel No.	Frequency (MHz)	Measurement Level (kHz)	Limit (kHz)	Limit of (2/3)*20dB Bandwidth (kHz)	Result
00	2402	1000	>25 kHz	946.7	Pass
39	2441	1000	>25 kHz	953.3	Pass
78	2480	1000	>25 kHz	946.7	Pass

NOTE: The 20dB Bandwidth is refer to section 10.

Channel 00 2402MHz

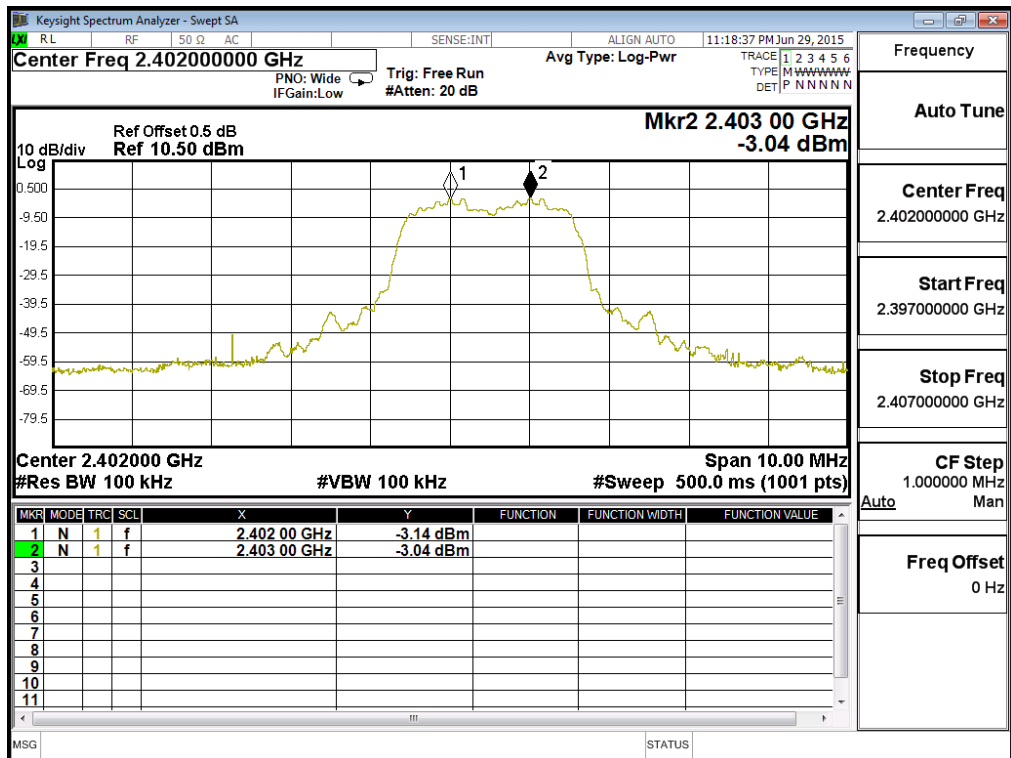

Channel 39 2441MHz

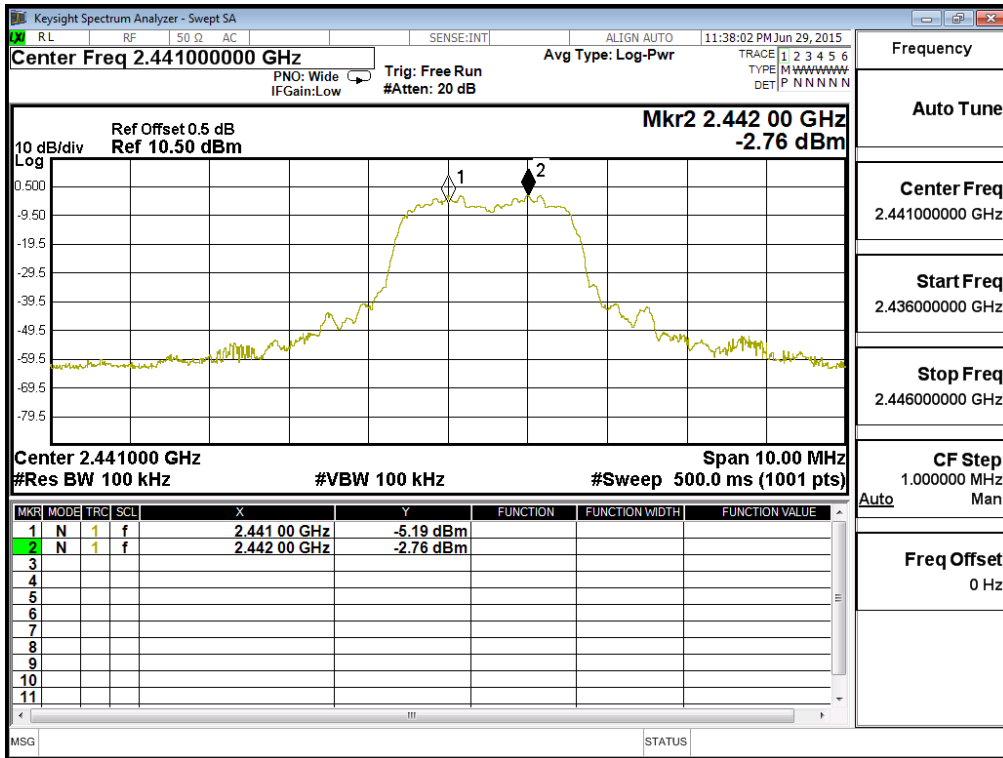

Channel 78 2480 MHz

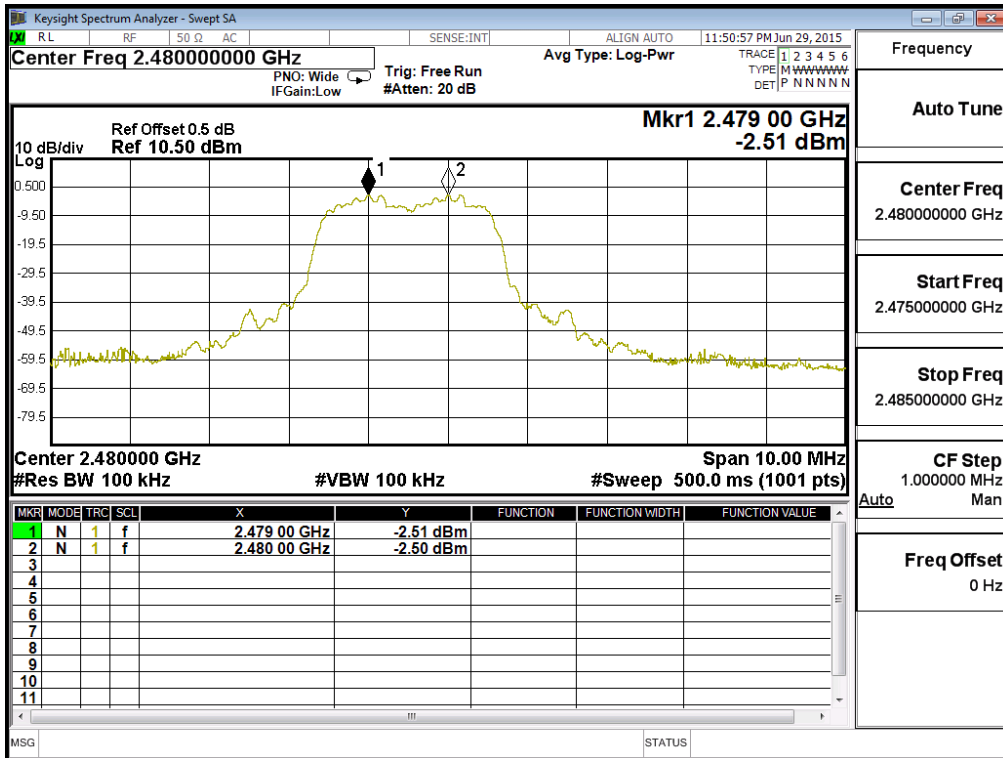

9. Dwell Time

9.1. Test Equipment

	Equipment	Manufacturer	Model No./Serial No.	Last Cal.
	Spectrum Analyzer	R&S	FSP40 / 100170	Jun, 2015
	Spectrum Analyzer	Agilent	E4407B / US39440758	Jun, 2015
X	Spectrum Analyzer	Agilent	N9010A / MY48030495	Apr., 2015

Note: 1. All equipments are calibrated every one year.
2. The test instruments marked by “X” are used to measure the final test results.

9.2. Test Setup

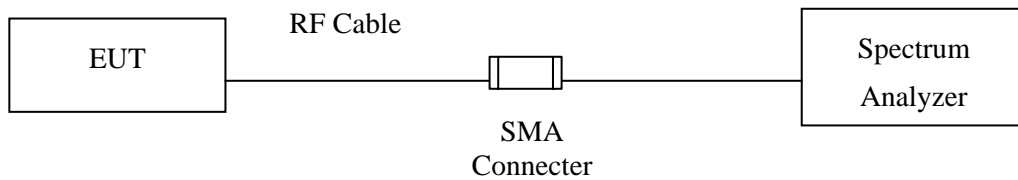

9.3. Limit

The dwell time shall be the average time of occupancy on any frequency shall not be greater than 0.4 seconds within a 30 second period.

9.4. Test Procedure

The EUT was setup to ANSI C63.4, 2014; tested to FHSS test procedure of FCC Public Notice DA 00-705 for compliance to FCC 47CFR 15.247 requirements.

9.5. Uncertainty

± 25msec

9.6. Test Result of Dwell Time

Product : TABLET PC
 Test Item : Dwell Time
 Test Site : No.3 OATS
 Test Mode : Mode 1: Transmit - 1Mbps (GFSK) (Channel 00,39,78 –DH5)

Frequency (MHz)	Time slot length (ms)	Hopping of Number	Sweep time (ms)	Duty cycle	Dwell Time (Sec)	Limit (Sec)	Result
2402	2.887	13	50	0.75	0.300	0.4	Pass
2441	2.887	13	50	0.75	0.300	0.4	Pass
2480	2.887	13	50	0.75	0.300	0.4	Pass

Duty cycle = ((Time slot length(ms)*Hopping of Number) / Sweep time (ms))

Dwell time = (Duty cycle /79) * (79*0.4)

CH 00 Time Interval between hops

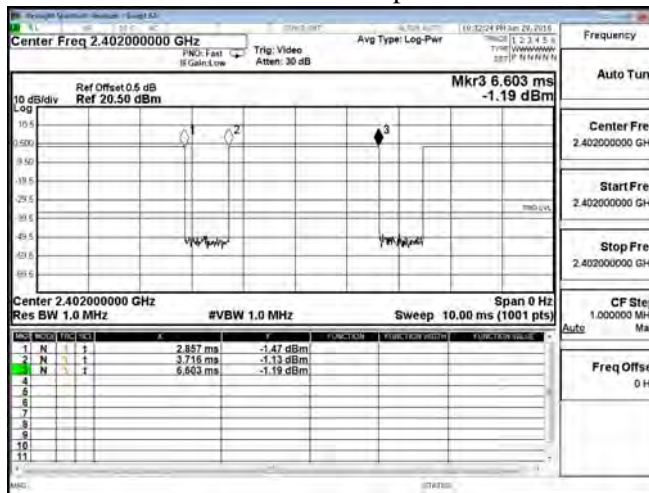

CH 00 Transmission Time

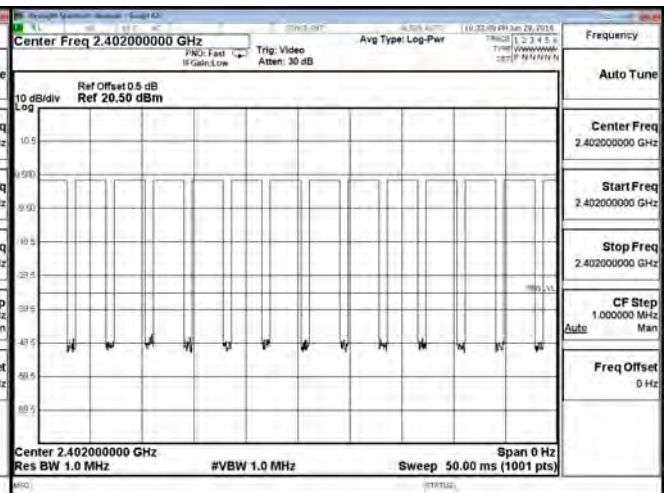

CH39 Time Interval between hops

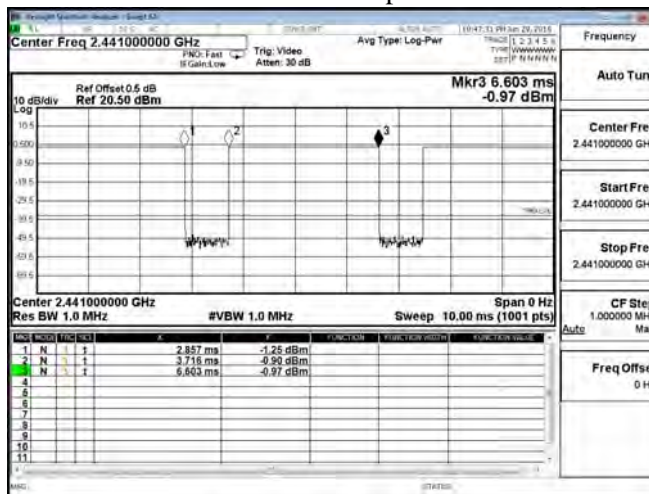

CH 39Transmission Time

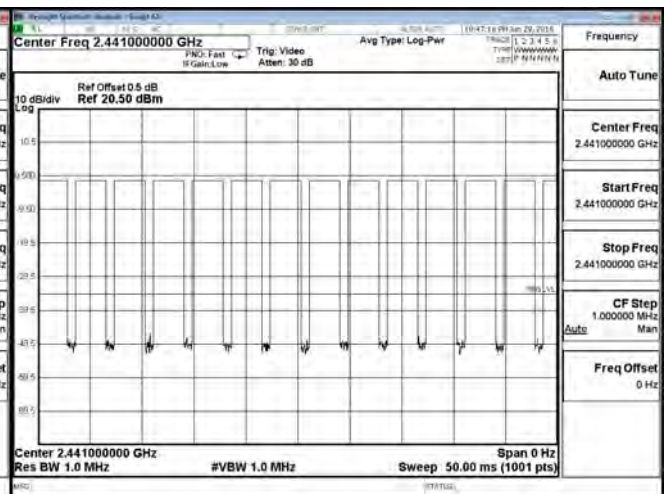

CH 78 Time Interval between hops

CH 78 Transmission Time

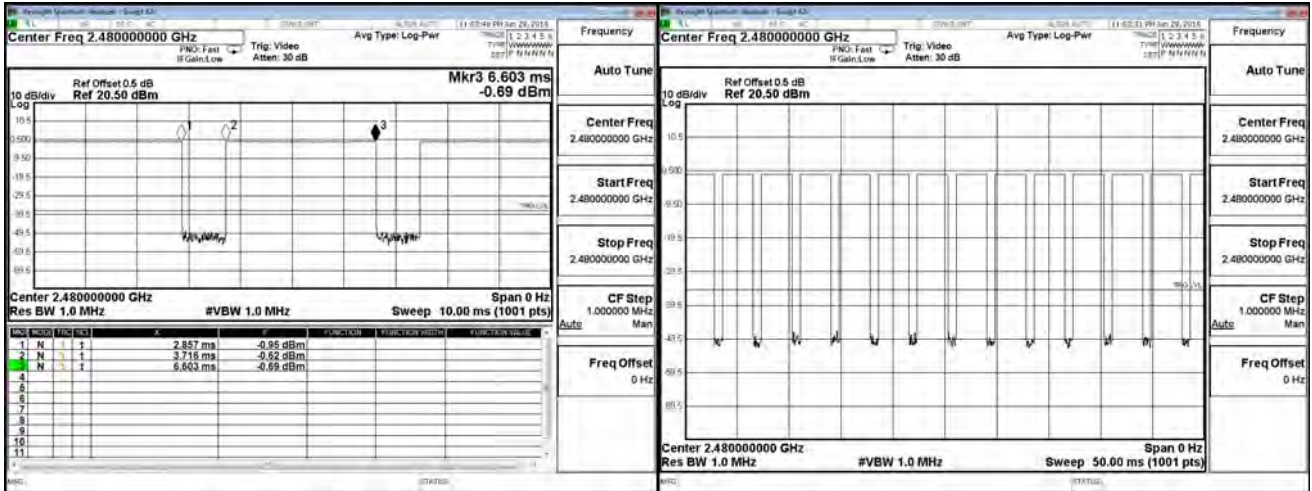

Note:

The dwell times of the packet type of DH1, DH3, and DH5 are tested. Only the worst case is shown on the report.

Product : TABLET PC
 Test Item : Dwell Time
 Test Site : No.3 OATS
 Test Mode : Mode 2: Transmit - 3Mbps (8DPSK) (Channel 00,39,78 –DH5)

Frequency (MHz)	Time slot length (ms)	Hopping of Number	Sweep time (ms)	Duty cycle	Dwell Time (Sec)	Limit (Sec)	Result
2402	2.887	13	50	0.75	0.300	0.4	Pass
2441	2.887	13	50	0.75	0.300	0.4	Pass
2480	2.887	13	50	0.75	0.300	0.4	Pass

Duty cycle = ((Time slot length(ms)*Hopping of Number) / Sweep time (ms))

Dwell time = (Duty cycle /79) * (79*0.4)

CH 00 Time Interval between hops

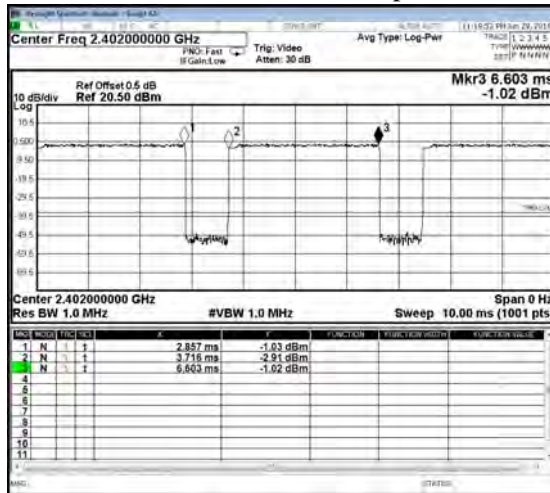

CH 00 Transmission Time

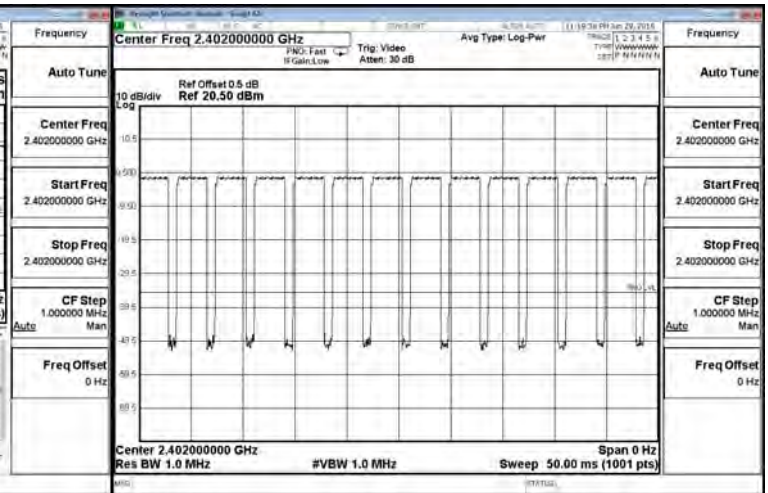

CH39 Time Interval between hops

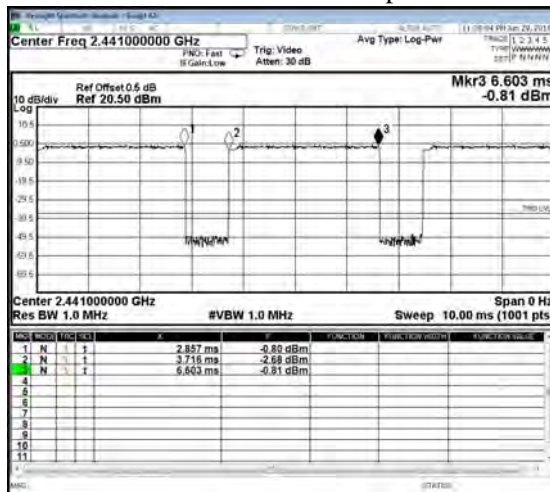

CH 39 Transmission Time

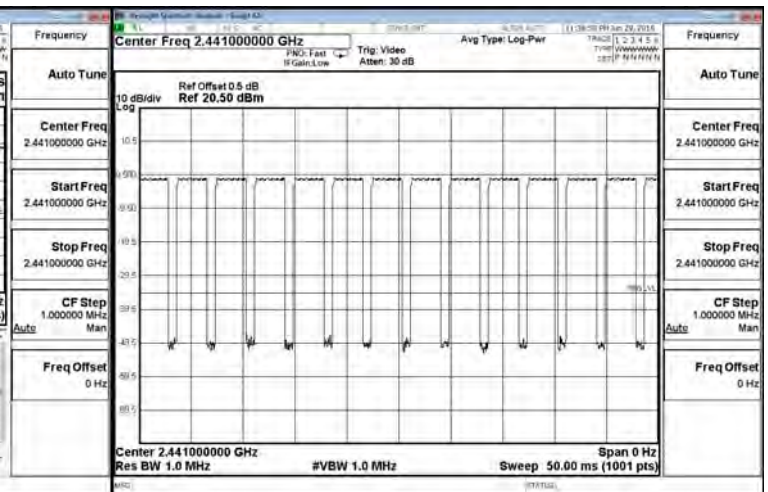

CH 78 Time Interval between hops

CH 78 Transmission Time

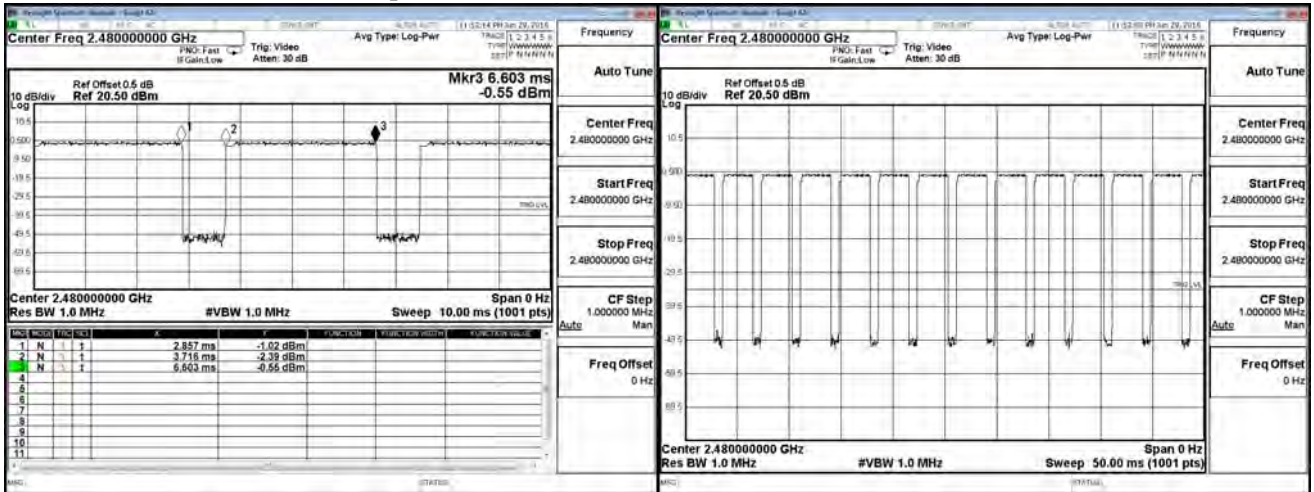

Note:

The dwell times of the packet type of DH1, DH3, and DH5 are tested. Only the worst case is shown on the report.

10. Occupied Bandwidth

10.1. Test Equipment

	Equipment	Manufacturer	Model No./Serial No.	Last Cal.
	Spectrum Analyzer	R&S	FSP40 / 100170	Jun, 2015
	Spectrum Analyzer	Agilent	E4407B / US39440758	Jun, 2015
X	Spectrum Analyzer	Agilent	N9010A / MY48030495	Apr., 2015

Note: 1. All equipments are calibrated every one year.
 2. The test instruments marked by “X” are used to measure the final test results.

10.2. Test Setup

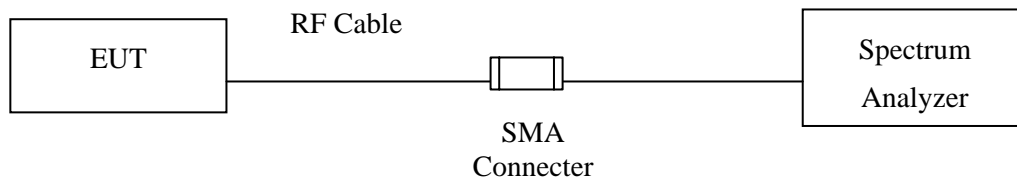

10.3. Limits

N/A

10.4. Test Procedure

The EUT was setup to ANSI C63.4, 2014; tested to FHSS test procedure of FCC Public Notice DA 00-705 for compliance to FCC 47CFR 15.247 requirements.

10.5. Uncertainty

± 150Hz

10.6. Test Result of Occupied Bandwidth

Product : TABLET PC
 Test Item : Occupied Bandwidth Data
 Test Site : No.3 OATS
 Test Mode : Mode 1: Transmit - 1Mbps (GFSK)(2402MHz)

Channel No.	Frequency (MHz)	Measurement Level (kHz)	Required Limit (kHz)	Result
00	2402	1110	--	NA

Figure Channel 00:

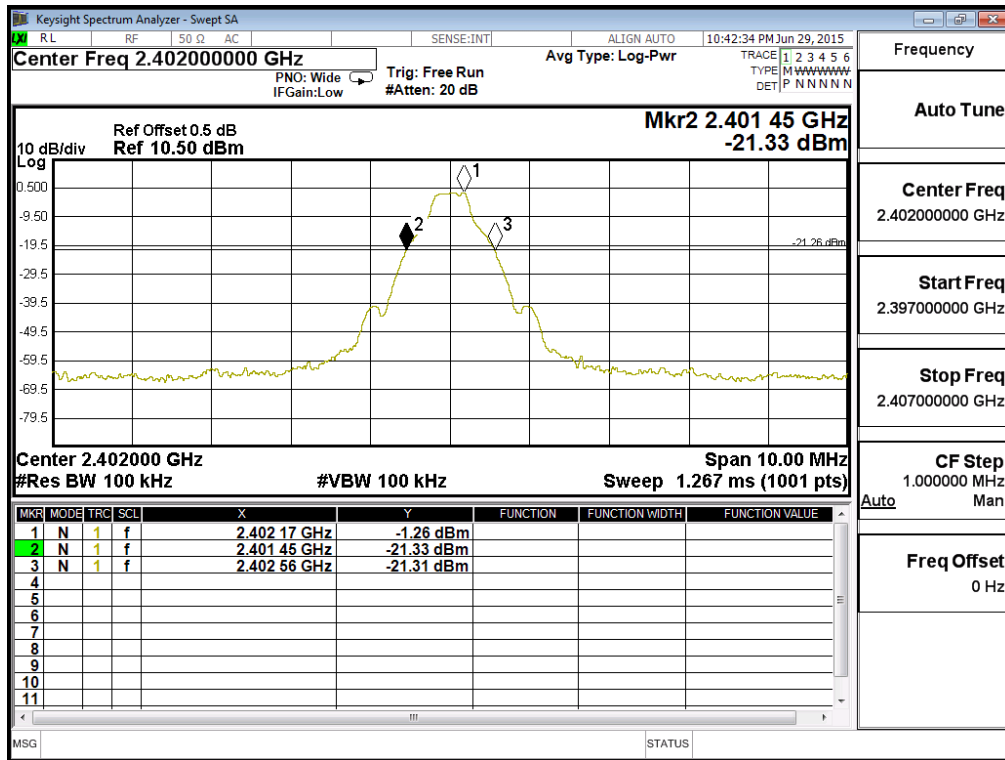

Product : TABLET PC
 Test Item : Occupied Bandwidth Data
 Test Site : No.3 OATS
 Test Mode : Mode 1: Transmit - 1Mbps (GFSK)(2441MHz)

Channel No.	Frequency (MHz)	Measurement Level (kHz)	Required Limit (kHz)	Result
39	2441	1110	--	NA

Figure Channel 39:

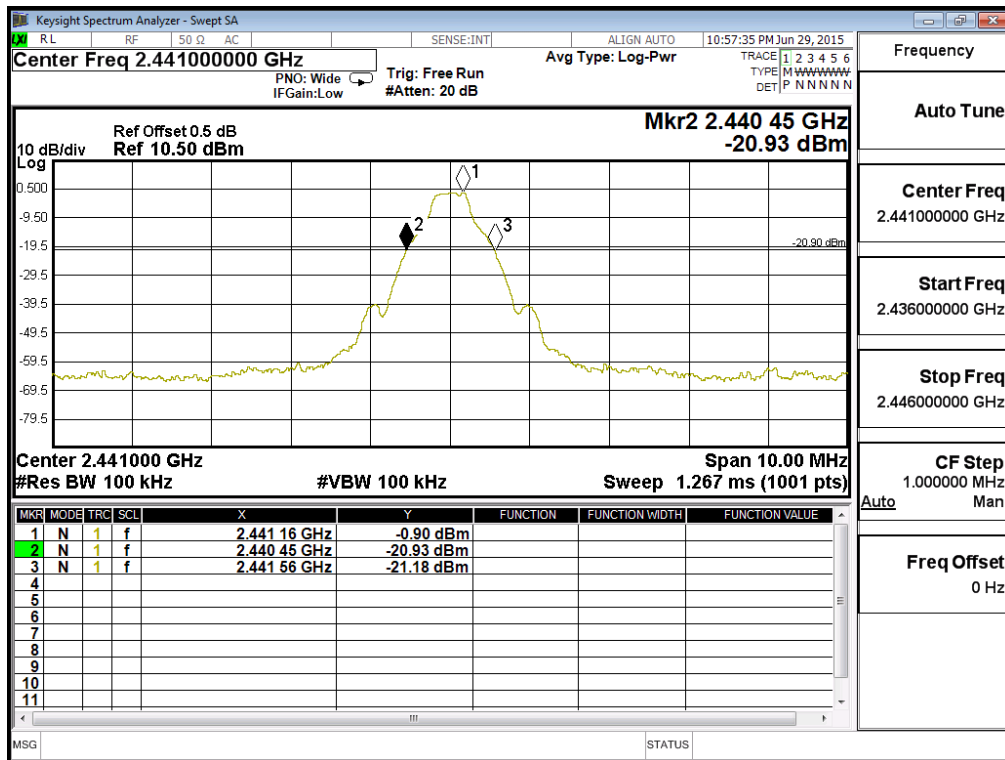

Product : TABLET PC
 Test Item : Occupied Bandwidth Data
 Test Site : No.3 OATS
 Test Mode : Mode 1: Transmit - 1Mbps (GFSK)(2480MHz)

Channel No.	Frequency (MHz)	Measurement Level (kHz)	Required Limit (kHz)	Result
78	2480	1130	--	NA

Figure Channel 78:

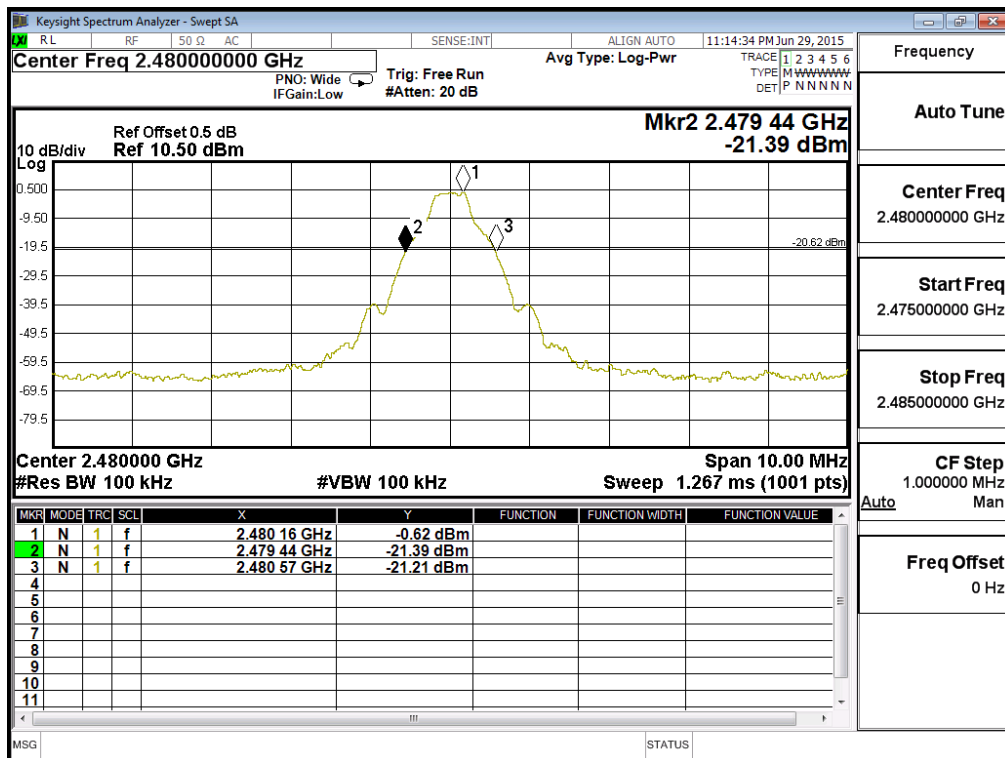

Product : TABLET PC
 Test Item : Occupied Bandwidth Data
 Test Site : No.3 OATS
 Test Mode : Mode 2: Transmit - 3Mbps (8DPSK) (2402MHz)

Channel No.	Frequency (MHz)	Measurement Level (kHz)	Required Limit (kHz)	Result
00	2402	1420	--	NA

Figure Channel 00:

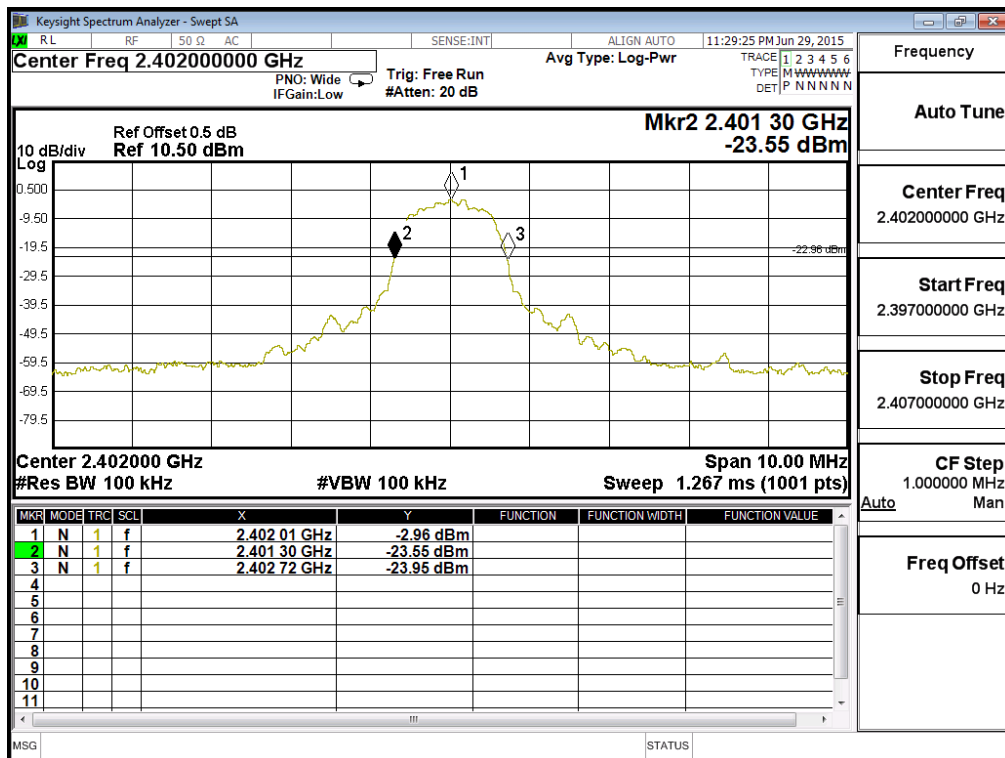

Product : TABLET PC
 Test Item : Occupied Bandwidth Data
 Test Site : No.3 OATS
 Test Mode : Mode 2: Transmit - 3Mbps (8DPSK) (2441MHz)

Channel No.	Frequency (MHz)	Measurement Level (kHz)	Required Limit (kHz)	Result
39	2441	1430	--	NA

Figure Channel 39:

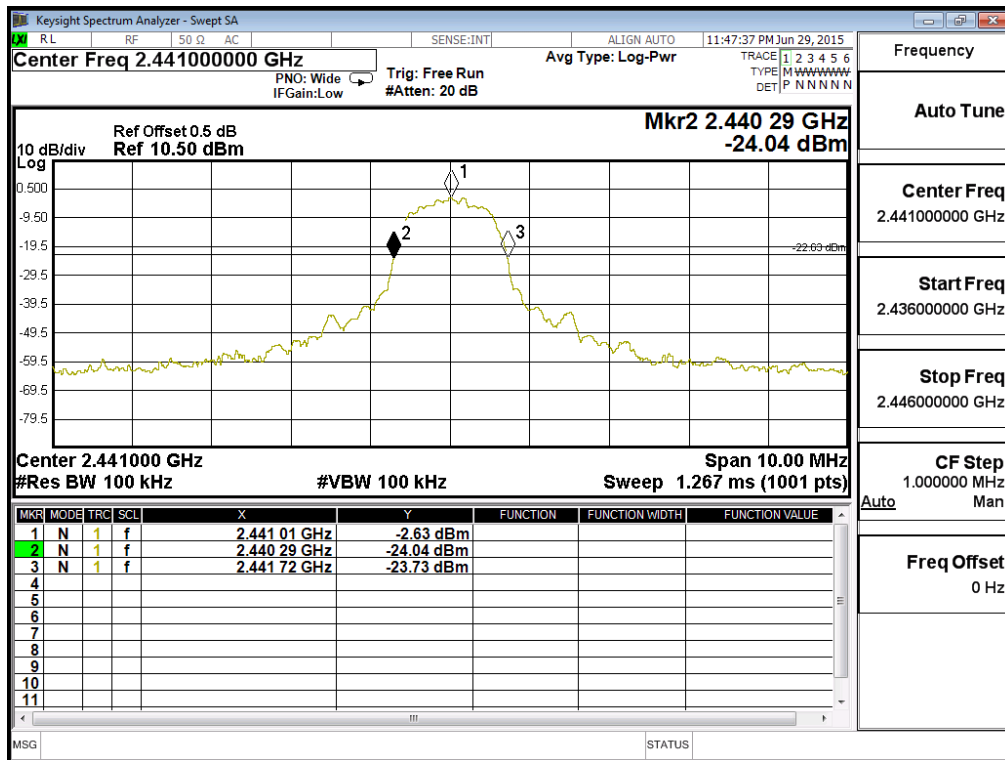

Product : TABLET PC
 Test Item : Occupied Bandwidth Data
 Test Site : No.3 OATS
 Test Mode : Mode 2: Transmit - 3Mbps (8DPSK)(2480MHz)

Channel No.	Frequency (MHz)	Measurement Level (kHz)	Required Limit (kHz)	Result
78	2480	1420	--	NA

Figure Channel 78:

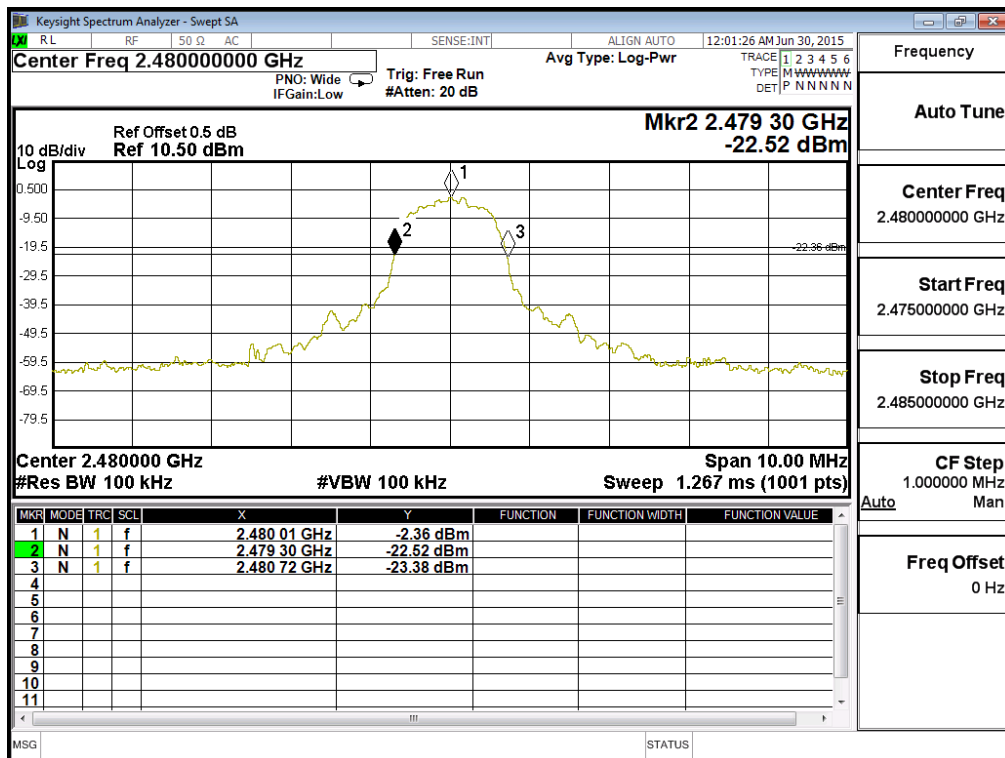

11. EMI Reduction Method During Compliance Testing

No modification was made during testing.