

# FCC Test Report

## (Class II Permissive Change)

Product Name	WiFi SOM Module
Model No.	MS-01
FCC ID.	2ABTU-MS01

Applicant	RuggON Corporation
Address	4F, No. 298, Yang Guang St., Neihu Dist., Taipei City, Taiwan

Date of Receipt	Dec. 06, 2019
Issued Date	Jan. 16, 2020
Report No.	19C0098R-RFUSP01V00
Report Version	V1.0



The test results relate only to the samples tested.

The test results shown in the test report are traceable to the national/international standard through the calibration report of the equipment and evaluated measurement uncertainty herein.

This report must not be used to claim product endorsement by TAF or any agency of the government.

The test report shall not be reproduced without the written approval of DEKRA Testing and Certification Co., Ltd.

# Test Report

Issued Date: Jan. 16, 2020

Report No.: 19C0098R-RFUSP01V00



Product Name	WiFi SOM Module
Applicant	RuggON Corporation
Address	4F, No. 298, Yang Guang St., Neihu Dist., Taipei City, Taiwan
Manufacturer	RuggON Corporation
Model No.	MS-01
FCC ID.	2ABTU-MS01
EUT Rated Voltage	DC 3.3V
EUT Test Voltage	DC 3.3V
Trade Name	RuggON
Applicable Standard	FCC CFR Title 47 Part 15 Subpart C ANSI C63.4: 2014, ANSI C63.10: 2013
Test Result	Complied

Documented By :

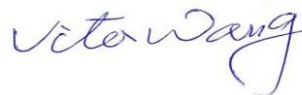

( Adm. Specialist / Vita Wang )

Tested By :



( Engineer / Sam Hsu )

Approved By :



( Director / Vincent Lin )

## TABLE OF CONTENTS

Description	Page
<b>1. GENERAL INFORMATION.....</b>	<b>4</b>
1.1. EUT Description .....	4
1.2. Operational Description.....	6
1.3. Tested System Details.....	7
1.4. Configuration of Tested System .....	7
1.5. EUT Exercise Software .....	7
1.6. Test Facility.....	8
1.7. List of Test Item and Equipment .....	9
<b>2. PEAK POWER OUTPUT.....</b>	<b>11</b>
2.1. Test Setup.....	11
2.2. Limit .....	11
2.3. Test Procedure.....	11
2.4. Uncertainty.....	11
2.5. Test Result of Peak Power Output.....	12
<b>3. RADIATED EMISSION .....</b>	<b>15</b>
3.1. Test Setup.....	15
3.2. Limits.....	16
3.3. Test Procedure.....	17
3.4. Uncertainty.....	17
3.5. Test Result of Radiated Emission.....	18
<b>4. BAND EDGE.....</b>	<b>42</b>
4.1. Test Setup.....	42
4.2. Limit .....	43
4.3. Test Procedure.....	43
4.4. Uncertainty.....	43
4.5. Test Result of Band Edge.....	44
<b>5. DUTY CYCLE.....</b>	<b>56</b>
5.1. Test Setup.....	56
5.2. Uncertainty.....	56
5.3. Test Result of Duty Cycle .....	57
<b>6. EMI REDUCTION METHOD DURING COMPLIANCE TESTING.....</b>	<b>60</b>
Attachment 1: EUT Test Photographs	
Attachment 2: EUT Detailed Photographs – Externa	
Attachment 3: EUT Detailed Photographs – Internal	

## 1. GENERAL INFORMATION

### 1.1. EUT Description

Product Name	WiFi SOM Module
Trade Name	RuggON
Model No.	MS-01
FCC ID.	2ABTU-MS01
Frequency Range	2402 – 2480MHz
Channel Number	79
Type of Modulation	FHSS: GFSK(1Mbps) / $\pi$ /4DQPSK(2Mbps) / 8DPSK(3Mbps)
Antenna Type	PIFA Antenna
Channel Control	Auto
Antenna Gain	Refer to the table “Antenna List”

#### Antenna List:

No.	Manufacturer	Part No.	Antenna Type	Peak Gain
1	AnJie	AJDP1J-B0006	PIFA	3.62dBi for 2.4 GHz

Note: The antenna of EUT is conform to FCC 15.203

Center Frequency of Each Channel: (For V3.0+HS, V2.1+EDR)

Channel	Frequency	Channel	Frequency	Channel	Frequency	Channel	Frequency
Channel 00:	2402 MHz	Channel 20:	2422 MHz	Channel 40:	2442 MHz	Channel 60:	2462 MHz
Channel 01:	2403 MHz	Channel 21:	2423 MHz	Channel 41:	2443 MHz	Channel 61:	2463 MHz
Channel 02:	2404 MHz	Channel 22:	2424 MHz	Channel 42:	2444 MHz	Channel 62:	2464 MHz
Channel 03:	2405 MHz	Channel 23:	2425 MHz	Channel 43:	2445 MHz	Channel 63:	2465 MHz
Channel 04:	2406 MHz	Channel 24:	2426 MHz	Channel 44:	2446 MHz	Channel 64:	2466 MHz
Channel 05:	2407 MHz	Channel 25:	2427 MHz	Channel 45:	2447 MHz	Channel 65:	2467 MHz
Channel 06:	2408 MHz	Channel 26:	2428 MHz	Channel 46:	2448 MHz	Channel 66:	2468 MHz
Channel 07:	2409 MHz	Channel 27:	2429 MHz	Channel 47:	2449 MHz	Channel 67:	2469 MHz
Channel 08:	2410 MHz	Channel 28:	2430 MHz	Channel 48:	2450 MHz	Channel 68:	2470 MHz
Channel 09:	2411 MHz	Channel 29:	2431 MHz	Channel 49:	2451 MHz	Channel 69:	2471 MHz
Channel 10:	2412 MHz	Channel 30:	2432 MHz	Channel 50:	2452 MHz	Channel 70:	2472 MHz
Channel 11:	2413 MHz	Channel 31:	2433 MHz	Channel 51:	2453 MHz	Channel 71:	2473 MHz
Channel 12:	2414 MHz	Channel 32:	2434 MHz	Channel 52:	2454 MHz	Channel 72:	2474 MHz
Channel 13:	2415 MHz	Channel 33:	2435 MHz	Channel 53:	2455 MHz	Channel 73:	2475 MHz
Channel 14:	2416 MHz	Channel 34:	2436 MHz	Channel 54:	2456 MHz	Channel 74:	2476 MHz
Channel 15:	2417 MHz	Channel 35:	2437 MHz	Channel 55:	2457 MHz	Channel 75:	2477 MHz
Channel 16:	2418 MHz	Channel 36:	2438 MHz	Channel 56:	2458 MHz	Channel 76:	2478 MHz
Channel 17:	2419 MHz	Channel 37:	2439 MHz	Channel 57:	2459 MHz	Channel 77:	2479 MHz
Channel 18:	2420 MHz	Channel 38:	2440 MHz	Channel 58:	2460 MHz	Channel 78:	2480 MHz
Channel 19:	2421 MHz	Channel 39:	2441 MHz	Channel 59:	2461 MHz		

Note:

1. The EUT is a WiFi SOM Module, contains functions WLAN (802.11a/b/g/n/ac) with Bluetooth (V5.0 and V3.0+HS, V2.1+EDR) combo card module transceiver, this report for Bluetooth V3.0+HS, V2.1+EDR.
2. These tests were conducted on a sample for the purpose of demonstrating compliance of transmitter with Part 15 Subpart C Paragraph 15.247 for spread spectrum devices.
3. Regarding to the operation frequency, the lowest, middle and highest frequency are selected to perform the test.
4. This is to request a Class II permissive change for FCC ID: 2ABTU-MS01, originally granted on 12/24/2019.

The major change filed under this application is:

Change #1: Addition an new antenna, antenna type is different with the original application.

(Antenna type: PIFA antenna)

#2: Reduce the Output Power through firmware.

Test Mode	Mode 1: Bluetooth 1Mbps Mode 2: Bluetooth 2Mbps Mode 3: Bluetooth 3Mbps
-----------	---

### 1.3. Tested System Details

The types for all equipment, plus descriptions of all cables used in the tested system (including inserted cards) are:

Product	Manufacturer	Model No.	Serial No.	Power Cord	
1	Notebook PC	DELL	Latitude 5580	2HRD7H2	Non-Shielded, 0.8m
2	Test Fixture	RuggON	N/A	N/A	N/A

Signal Cable Type	Signal cable Description	
A	USB Cable	Shielded, 1m
B	Power Cable	Shielded, 1.8m

### 1.4. Configuration of Tested System

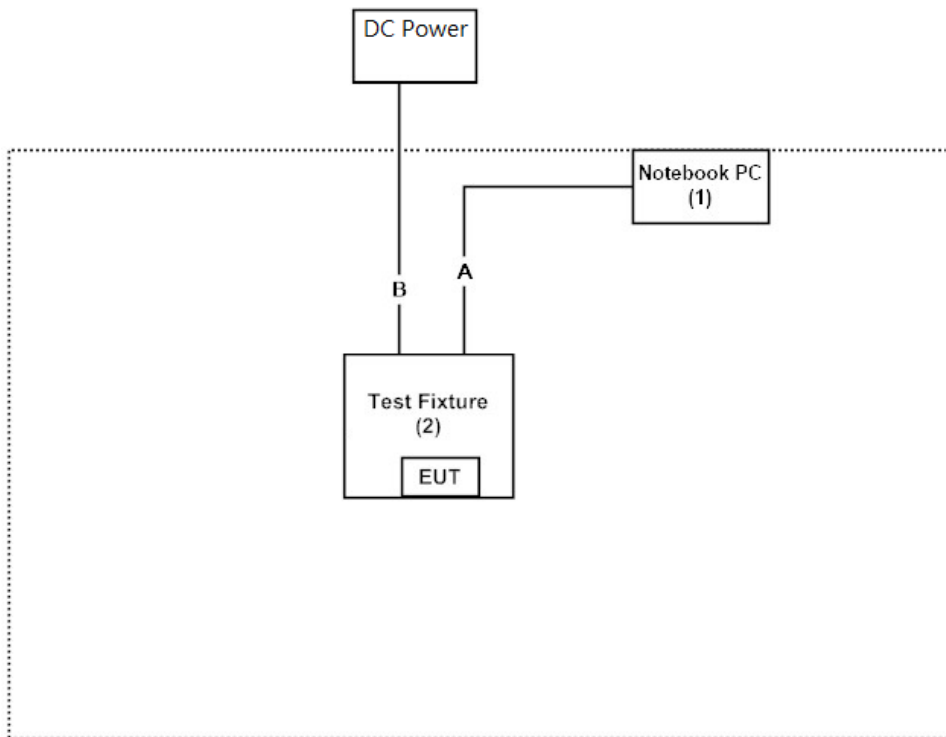

### 1.5. EUT Exercise Software

- (1) Setup the EUT as shown on 1.4
- (2) Execute software “QRCT3 V3.0.268.0” on the EUT.
- (3) Configure the test mode, the test channel, and the data rate.
- (4) Start the continuous transmission.
- (5) Verify that the EUT works properly.

## 1.6. Test Facility

Ambient conditions in the laboratory:

Items	Required (IEC 68-1)	Actual
Temperature (°C)	15-35	20-35
Humidity (%RH)	25-75	50-65
Barometric pressure (mbar)	860-1060	950-1000

**USA : FCC Registration Number: TW3023**

**Canada : IC Registration Number: 4075A**

Site Description: Accredited by TAF  
Accredited Number: 3023

Test Laboratory: DEKRA Testing and Certification Co., Ltd  
Address: No.5-22, Ruishukeng, Linkou Dist., New Taipei City 24451,  
Taiwan, R.O.C.

Phone number: 886-2-8601-3788

Fax number: 886-2-8601-3789

Email address: [info.tw@dekra.com](mailto:info.tw@dekra.com)

Website: <http://www.dekra.com.tw>

## 1.7. List of Test Item and Equipment

### For Conducted measurements /CB3/SR8

	Equipment	Manufacturer	Model No.	Serial No.	Cali. Date	Due. Date
	Temperature Chamber	WIT GROUP	TH-1S-B	EQ-201-00146	<u>2019/02/26</u>	2020/02/25
X	Spectrum Analyzer	Agilent	N9010A	MY53470892	2019/09/25	2020/09/24
X	Peak Power Analyzer	Keysight	8990B	MY51000410	2019/07/30	2020/07/29
X	Wideband Power Sensor	Keysight	N1923A	MY56080003	2019/07/30	2020/07/29
X	Wideband Power Sensor	Keysight	N1923A	MY56080004	2019/07/30	2020/07/29
X	EMI Test Receiver	R&S	ESCS 30	100369	<u>2019/11/19</u>	2020/11/18
X	LISN	R&S	ENV216	101105	2019/04/10	2020/04/09
X	LISN	R&S	ESH3-Z5	836679/014	2019/04/10	2020/04/09
X	Coaxial Cable	DEKRA	RG 400	LC018-RG	2019/06/20	2020/06/19

Note:

1. All equipments are calibrated every one year.
2. The test instruments marked with "X" are used to measure the final test results.
3. Test Software version : DEKRA Conduction Test SystemV9.0.5.



**For Radiated measurements /Site3/CB8**

	Equipment	Manufacturer	Model No.	Serial No.	Cali. Date	Due. Date
X	Spectrum Analyzer	R&S	FSP40	100170	<u>2019/03/11</u>	2020/03/10
X	Loop Antenna	Teseq	HLA6121	37133	2019/10/15	2021/10/14
X	Bilog Antenna	Schaffner Chase	CBL6112B	2794	2019/06/23	2020/06/22
X	Coaxial Cable	DEKRA	L1907-001C	280280.F141.1000D	2019/07/10	2020/07/09
X	Amplifier	EMCI	EMC001330	980254	2019/08/22	2020/08/21
X	Horn Antenna	ETS-LINDGREN	3117	00228113	<u>2019/05/02</u>	2020/05/01
	Coaxial Cable	DEKRA	L1907-002C	280280.F141.1000D	2019/07/10	2020/07/09
X	Amplifier	EMCI	EMC05820SE	980362	2019/06/26	2020/06/25
	Amplifier	EMCI	EMC051845SE	SN980632	2019/08/08	2020/08/07
X	Horn Antenna	Com-Power	AH-1840	101101	2019/10/31	2020/10/30
X	Amplifier + Cable	EMCI	EMC184045SE	980369	2019/04/16	2020/04/15
	Bilog Antenna	Schaffner Chase	CBL6112B	2916	2019/06/23	2020/06/22
	Coaxial Cable	DEKRA	L1907-003C	00100A1B3A120M	2019/07/10	2020/07/09
	Amplifier	EMCI	EMC001330	980255	2019/06/28	2020/06/27
X	Filter	MICRO-TRONICS	BRM50702	G270	2019/08/08	2020/08/07
X	Filter	MICRO-TRONICS	BRM50716	G196	2019/08/08	2020/08/07

## Note:

1. Loop Antenna is calibrated every two years, the other equipments are calibrated every one year.
2. The test instruments marked with "X" are used to measure the final test results.
3. Test Software version : DEKRA Test SystemV1.1.

## 2. Peak Power Output

### 2.1. Test Setup

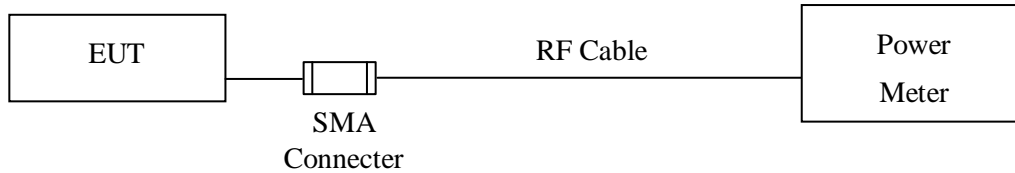

### 2.2. Limit

The maximum peak power shall be less 1Watt.

### 2.3. Test Procedure

The EUT was setup to ANSI C63.4, 2014; tested to FHSS test procedure of FCC Public Notice DA 00-705 for compliance to FCC 47CFR 15.247 requirements.

### 2.4. Uncertainty

$\pm 1.19$  dB

## 2.5. Test Result of Peak Power Output

Product : WiFi SOM Module  
Test Item : Peak Power Output  
Test Site : No.3 OATS  
Test date : 2019/12/27  
Test Mode : Mode 1: Bluetooth 1Mbps

Channel No.	Frequency (MHz)	Measurement (dBm)	Required Limit	Result
Channel 00	2402.00	6.21	1 Watt= 30 dBm	Pass
Channel 39	2441.00	5.53	1 Watt= 30 dBm	Pass
Channel 78	2480.00	6.11	1 Watt= 30 dBm	Pass

Product : WiFi SOM Module  
Test Item : Peak Power Output  
Test Site : No.3 OATS  
Test date : 2019/12/27  
Test Mode : Mode 2: Bluetooth 2Mbps

Channel No.	Frequency (MHz)	Measurement (dBm)	Required Limit	Result
Channel 00	2402.00	5.33	1 Watt= 30 dBm	Pass
Channel 39	2441.00	4.63	1 Watt= 30 dBm	Pass
Channel 78	2480.00	6.18	1 Watt= 30 dBm	Pass

Product : WiFi SOM Module  
Test Item : Peak Power Output  
Test Site : No.3 OATS  
Test date : 2019/12/27  
Test Mode : Mode 3: Bluetooth 3Mbps

Channel No.	Frequency (MHz)	Measurement (dBm)	Required Limit	Result
Channel 00	2402.00	5.81	1 Watt= 30 dBm	Pass
Channel 39	2441.00	4.98	1 Watt= 30 dBm	Pass
Channel 78	2480.00	6.04	1 Watt= 30 dBm	Pass

### 3. Radiated Emission

#### 3.1. Test Setup

Under 30MHz

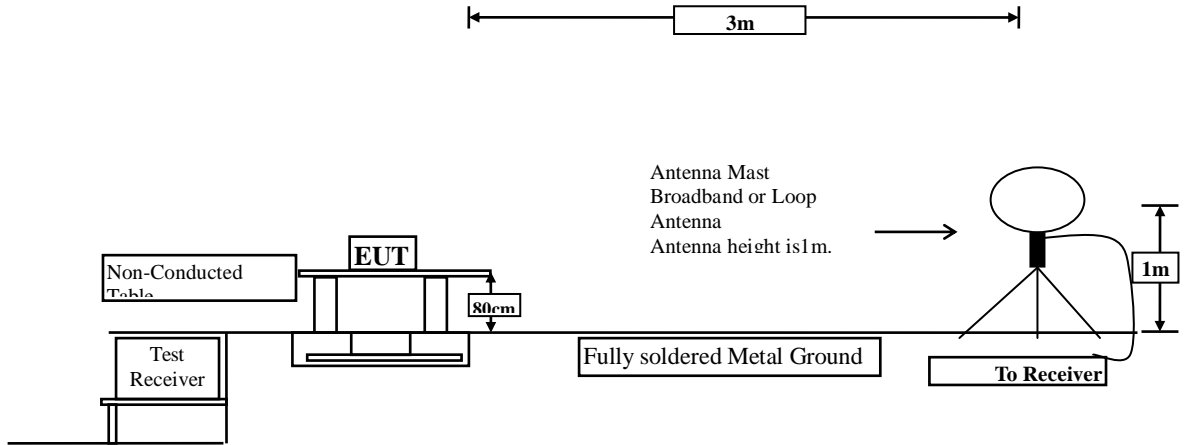

Below 1GHz

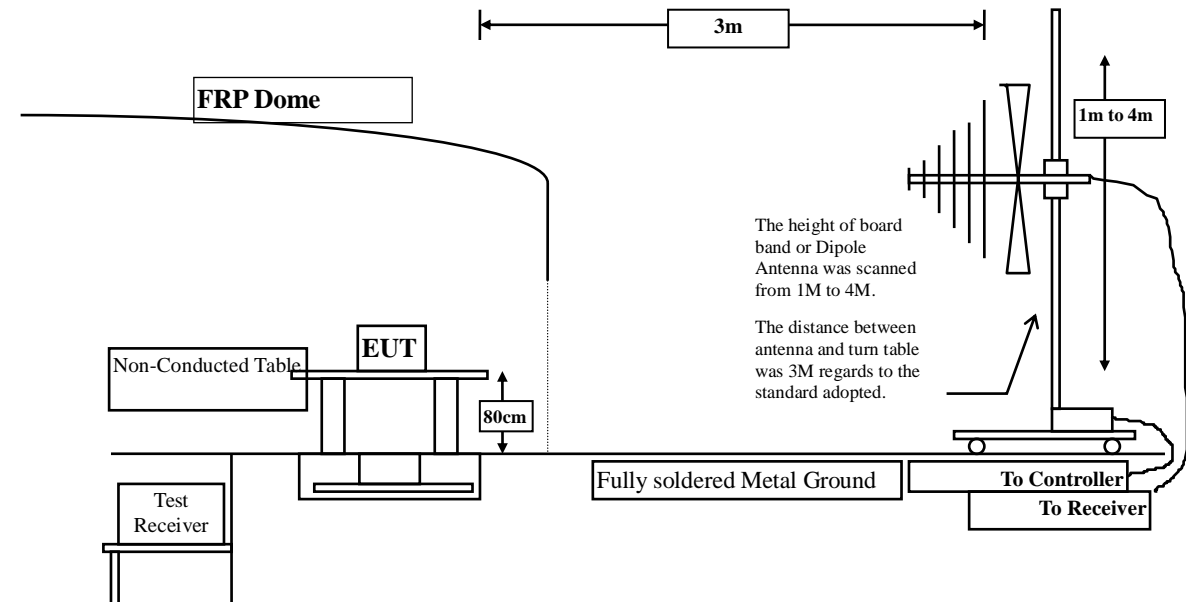

Above 1GHz

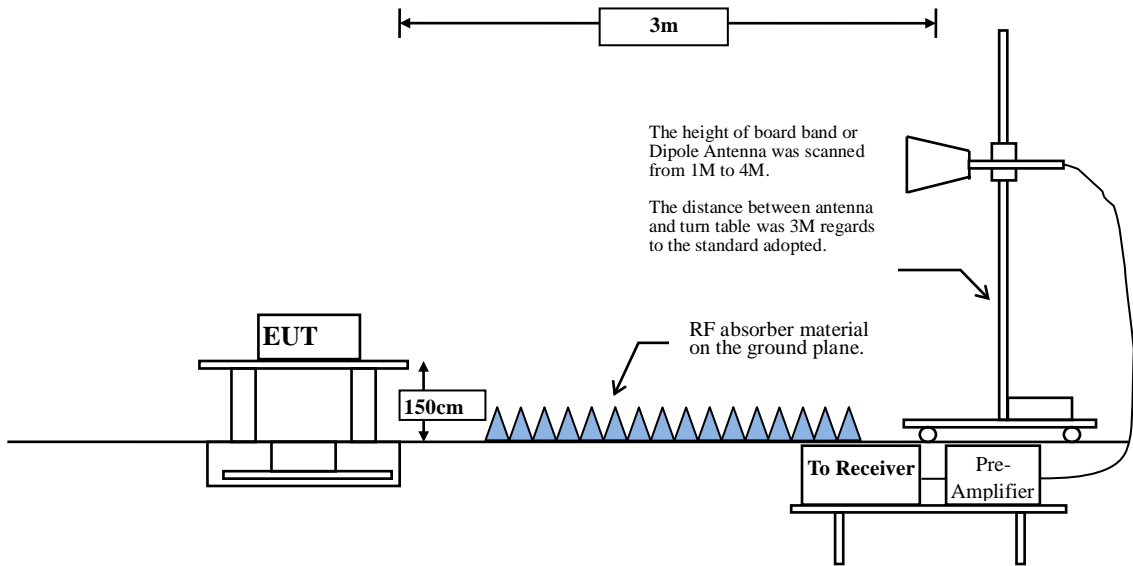

### 3.2. Limits

#### ➤ General Radiated Emission Limits

Emissions radiated outside of the specified frequency bands, except for harmonics, shall be attenuated by at least 20dB below the level of the fundamental or to the general radiated emission limits in paragraph 15.209, whichever is the lesser attenuation.

FCC Part 15 Subpart C Paragraph 15.209 Limits		
Frequency MHz	uV/m @3m	dBµV/m@3m
30-88	100	40
88-216	150	43.5
216-960	200	46
Above 960	500	54

- Remarks:
1. RF Voltage (dBµV) = 20 log RF Voltage (uV)
  2. In the Above Table, the tighter limit applies at the band edges.
  3. Distance refers to the distance in meters between the measuring instrument antenna and the closed point of any part of the device or system.

### 3.3. Test Procedure

The EUT was setup according to ANSI C63.10, 2013 and tested compliance to FCC 47CFR 15.247 requirements.

Measuring the frequency range below 1GHz, the EUT is placed on a turn table which is 0.8 meter above ground, when measuring the frequency range above 1GHz, the EUT is placed on a turn table which is 1.5 meter above ground.

The turn table is rotated 360 degrees to determine the position of the maximum emission level.

The EUT was positioned such that the distance from antenna to the EUT was 3 meters.

The antenna is scanned between 1 meter and 4 meters to find out the maximum emission level. This is repeated for both horizontal and vertical polarization of the antenna. In order to find the maximum emission, all of the interface cables were manipulated according to ANSI C63.10: 2013 on radiated measurement.

The resolution bandwidth below 30MHz setting on the field strength meter is 9kHz and 30MHz~1GHz is 120kHz and above 1GHz is 1MHz.

Radiated emission measurements below 30MHz are made using Loop Antenna and 30MHz~1GHz are made using broadband Bilog antenna and above 1GHz are made using Horn Antennas.

The measurement is divided into the Preliminary Measurement and the Final Measurement.

The suspected frequencies are searched for in Preliminary Measurement with the measurement antenna kept pointed at the source of the emission both in azimuth and elevation, with the polarization of the antenna oriented for maximum response. The antenna is pointed at an angle towards the source of the emission, and the EUT is rotated in both height and polarization to maximize the measured emission. The emission is kept within the illumination area of the 3 dB bandwidth of the antenna.

The worst radiated emission is measured in the Open Area Test Site on the Final Measurement.

The measurement frequency range from 9kHz - 10th Harmonic of fundamental was investigated.

### 3.4. Uncertainty

± 4.08 dB above 1GHz

± 4.22 dB below 1GHz



### 3.5. Test Result of Radiated Emission

Product : WiFi SOM Module  
 Test Item : Harmonic Radiated Emission  
 Test Site : No.3 OATS  
 Test date : 2020/01/02  
 Test Mode : Mode 1: Bluetooth 1Mbps(2402MHz)

#### Horizontal

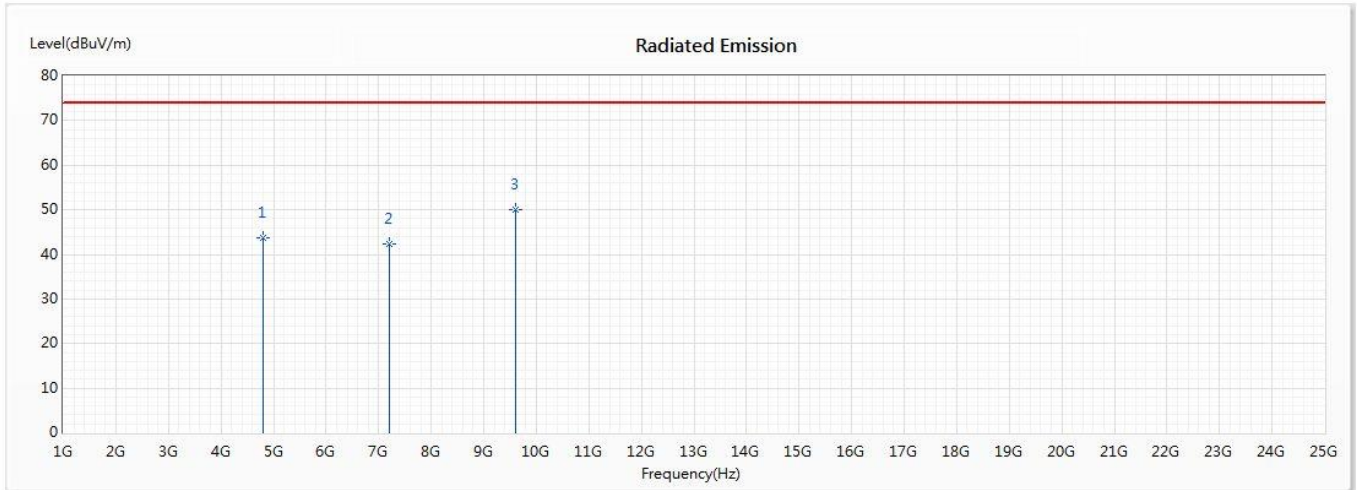

No	Frequency (MHz)	Emission Level (dBuV/m)	Limit (dBuV/m)	Margin (dB)	Reading Level (dBuV)	Correct Factor (dB/m)	Detector Type
1	4804	43.81	74.00	-30.19	55.96	-12.15	PK
2	7206	42.44	74.00	-31.56	55.58	-13.14	PK
* 3	9608	50.04	74.00	-23.96	63.46	-13.42	PK

#### Note:

1. All Readings below 1GHz are Quasi-Peak, above 1GHz are performed with peak and/or average measurements as necessary.
2. Peak measurements: RBW = 1MHz, VBW = 3 MHz, Sweep: Auto.
3. Average measurements: RBW = 1MHz, VBW = 10 Hz, Sweep: Auto.
4. Measurement Level = Reading Level + Correct Factor.
5. Correct Factor = Antenna factor + Cable loss – Amplifier gain.
6. The average measurement was not performed when the peak measured data under the limit of average detection.
7. The emission levels of other frequencies are very lower than the limit and not show in test report.

Product : WiFi SOM Module  
 Test Item : Harmonic Radiated Emission  
 Test Site : No.3 OATS  
 Test date : 2020/01/02  
 Test Mode : Mode 1: Bluetooth 1Mbps(2402MHz)

Vertical

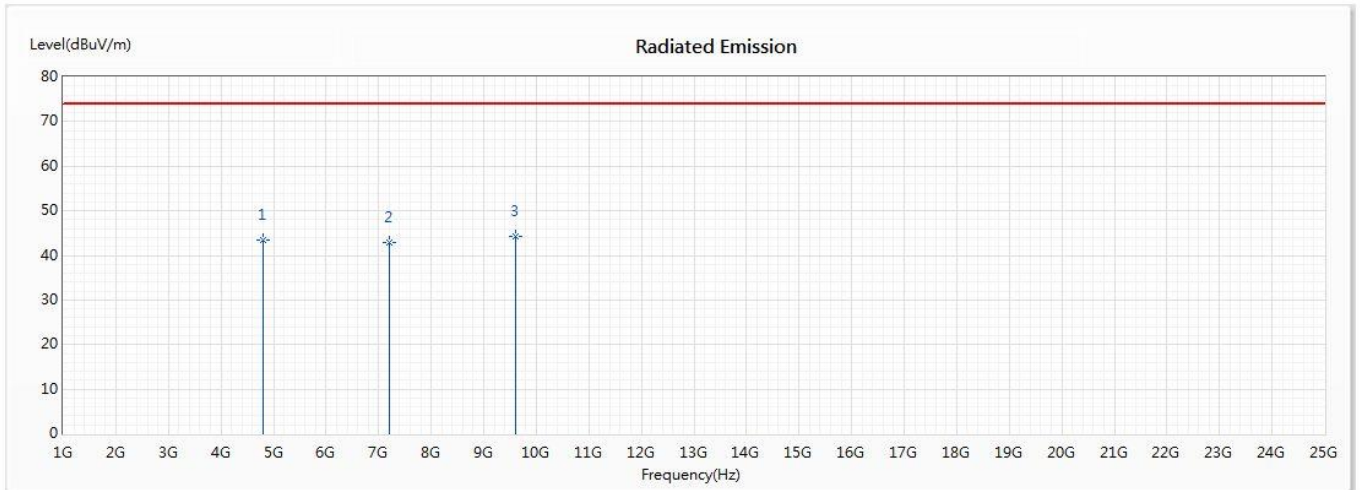

No	Frequency (MHz)	Emission Level (dBuV/m)	Limit (dBuV/m)	Margin (dB)	Reading Level (dBuV)	Correct Factor (dB/m)	Detector Type
1	4804	43.42	74.00	-30.58	55.57	-12.15	PK
2	7206	42.96	74.00	-31.04	56.10	-13.14	PK
* 3	9608	44.27	74.00	-29.73	57.69	-13.42	PK

Note:

1. All Readings below 1GHz are Quasi-Peak, above 1GHz are performed with peak and/or average measurements as necessary.
2. Peak measurements: RBW = 1MHz, VBW = 3 MHz, Sweep: Auto.
3. Average measurements: RBW = 1MHz, VBW = 10 Hz, Sweep: Auto.
4. Measurement Level = Reading Level + Correct Factor.
5. Correct Factor = Antenna factor + Cable loss – Amplifier gain.
6. The average measurement was not performed when the peak measured data under the limit of average detection.
7. The emission levels of other frequencies are very lower than the limit and not show in test report.

Product : WiFi SOM Module  
 Test Item : Harmonic Radiated Emission  
 Test Site : No.3 OATS  
 Test date : 2020/01/02  
 Test Mode : Mode 1: Bluetooth 1Mbps(2441MHz)

Horizontal

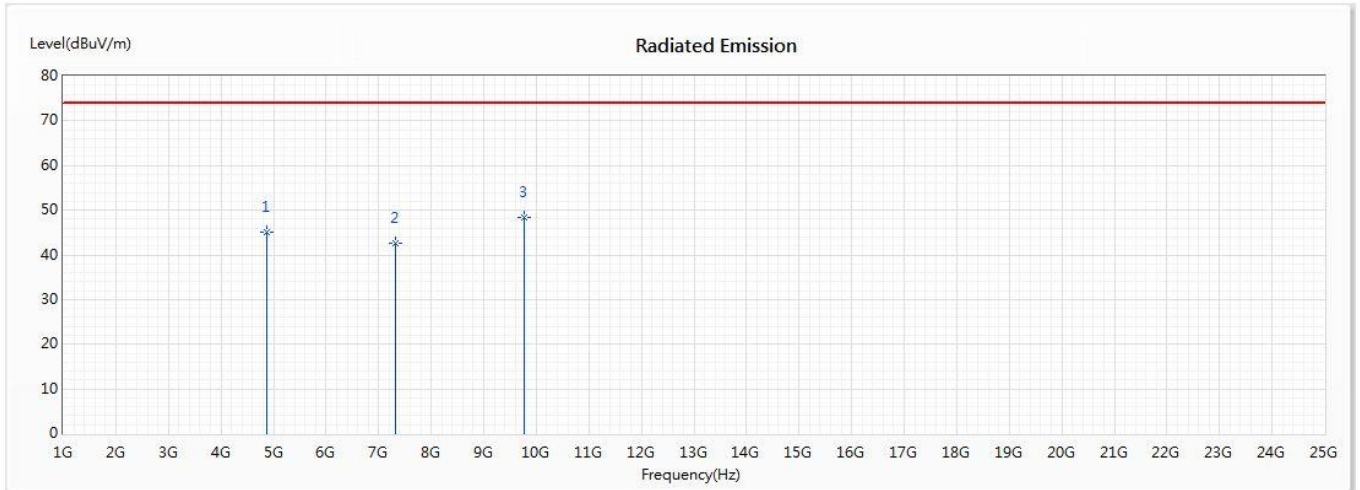

No	Frequency (MHz)	Emission Level (dBuV/m)	Limit (dBuV/m)	Margin (dB)	Reading Level (dBuV)	Correct Factor (dB/m)	Detector Type
1	4882	45.02	74.00	-28.98	56.61	-11.59	PK
2	7323	42.69	74.00	-31.31	56.26	-13.57	PK
* 3	9764	48.40	74.00	-25.60	60.92	-12.52	PK

Note:

1. All Readings below 1GHz are Quasi-Peak, above 1GHz are performed with peak and/or average measurements as necessary.
2. Peak measurements: RBW = 1MHz, VBW = 3 MHz, Sweep: Auto.
3. Average measurements: RBW = 1MHz, VBW = 10 Hz, Sweep: Auto.
4. Measurement Level = Reading Level + Correct Factor.
5. Correct Factor = Antenna factor + Cable loss – Amplifier gain.
6. The average measurement was not performed when the peak measured data under the limit of average detection.
7. The emission levels of other frequencies are very lower than the limit and not show in test report.

Product : WiFi SOM Module  
 Test Item : Harmonic Radiated Emission  
 Test Site : No.3 OATS  
 Test date : 2020/01/02  
 Test Mode : Mode 1: Bluetooth 1Mbps(2441MHz)

Vertical

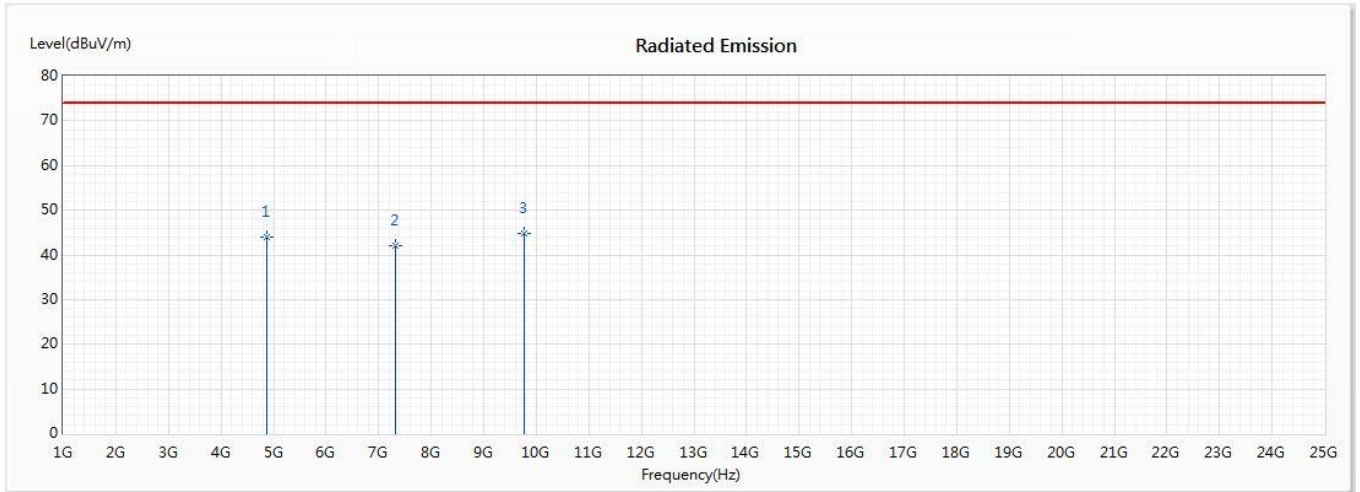

No	Frequency (MHz)	Emission Level (dBuV/m)	Limit (dBuV/m)	Margin (dB)	Reading Level (dBuV)	Correct Factor (dB/m)	Detector Type
1	4882	43.93	74.00	-30.07	55.52	-11.59	PK
2	7323	42.08	74.00	-31.92	55.65	-13.57	PK
* 3	9764	44.85	74.00	-29.15	57.37	-12.52	PK

Note:

1. All Readings below 1GHz are Quasi-Peak, above 1GHz are performed with peak and/or average measurements as necessary.
2. Peak measurements: RBW = 1MHz, VBW = 3 MHz, Sweep: Auto.
3. Average measurements: RBW = 1MHz, VBW = 10 Hz, Sweep: Auto.
4. Measurement Level = Reading Level + Correct Factor.
5. Correct Factor = Antenna factor + Cable loss – Amplifier gain.
6. The average measurement was not performed when the peak measured data under the limit of average detection.
7. The emission levels of other frequencies are very lower than the limit and not show in test report.

Product : WiFi SOM Module  
 Test Item : Harmonic Radiated Emission  
 Test Site : No.3 OATS  
 Test date : 2020/01/02  
 Test Mode : Mode 1: Bluetooth 1Mbps(2480MHz)

Horizontal

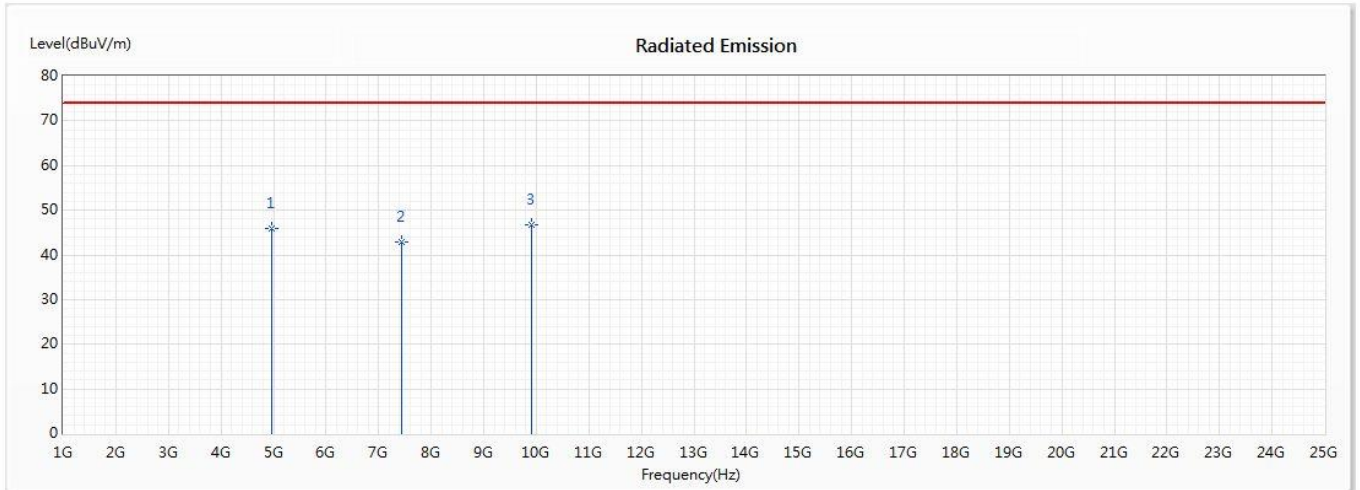

No	Frequency (MHz)	Emission Level (dBuV/m)	Limit (dBuV/m)	Margin (dB)	Reading Level (dBuV)	Correct Factor (dB/m)	Detector Type
1	4960	45.83	74.00	-28.17	56.72	-10.89	PK
2	7440	42.78	74.00	-31.22	57.40	-14.62	PK
* 3	9920	46.63	74.00	-27.37	60.86	-14.23	PK

Note:

1. All Readings below 1GHz are Quasi-Peak, above 1GHz are performed with peak and/or average measurements as necessary.
2. Peak measurements: RBW = 1MHz, VBW = 3 MHz, Sweep: Auto.
3. Average measurements: RBW = 1MHz, VBW = 10 Hz, Sweep: Auto.
4. Measurement Level = Reading Level + Correct Factor.
5. Correct Factor = Antenna factor + Cable loss – Amplifier gain.
6. The average measurement was not performed when the peak measured data under the limit of average detection.
7. The emission levels of other frequencies are very lower than the limit and not show in test report.

Product : WiFi SOM Module  
 Test Item : Harmonic Radiated Emission  
 Test Site : No.3 OATS  
 Test date : 2020/01/02  
 Test Mode : Mode 1: Bluetooth 1Mbps(2480MHz)

Vertical

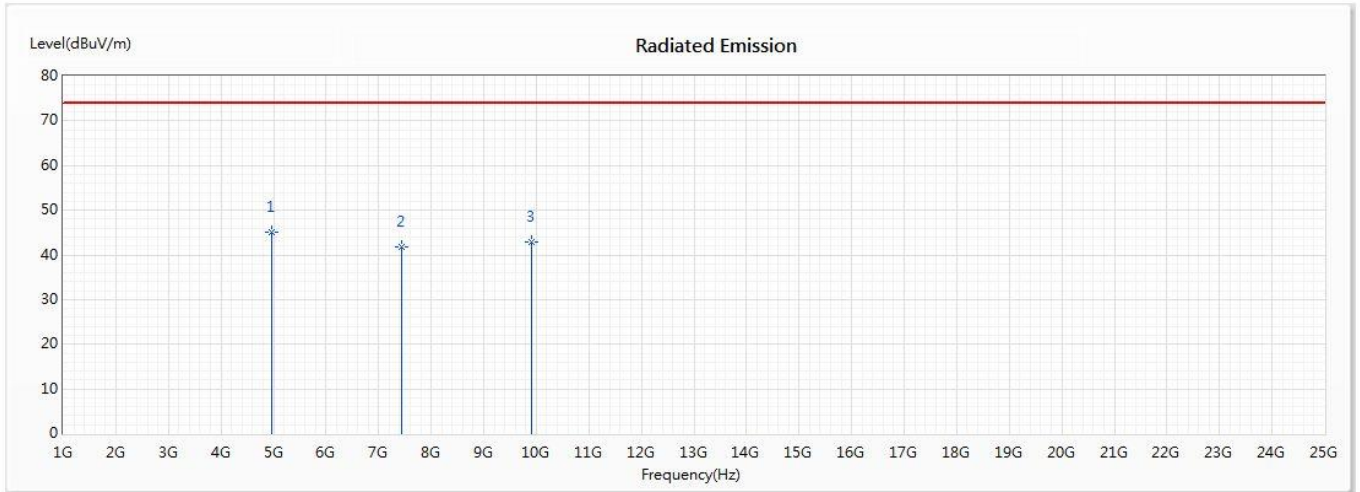

No	Frequency (MHz)	Emission Level (dBuV/m)	Limit (dBuV/m)	Margin (dB)	Reading Level (dBuV)	Correct Factor (dB/m)	Detector Type
* 1	4960	44.95	74.00	-29.05	55.84	-10.89	PK
2	7440	41.72	74.00	-32.28	56.34	-14.62	PK
3	9920	42.79	74.00	-31.21	57.02	-14.23	PK

Note:

1. All Readings below 1GHz are Quasi-Peak, above 1GHz are performed with peak and/or average measurements as necessary.
2. Peak measurements: RBW = 1MHz, VBW = 3 MHz, Sweep: Auto.
3. Average measurements: RBW = 1MHz, VBW = 10 Hz, Sweep: Auto.
4. Measurement Level = Reading Level + Correct Factor.
5. Correct Factor = Antenna factor + Cable loss – Amplifier gain.
6. The average measurement was not performed when the peak measured data under the limit of average detection.
7. The emission levels of other frequencies are very lower than the limit and not show in test report.



Product : WiFi SOM Module  
 Test Item : Harmonic Radiated Emission  
 Test Site : No.3 OATS  
 Test date : 2020/01/02  
 Test Mode : Mode 2: Bluetooth 2Mbps (2402MHz)

Horizontal

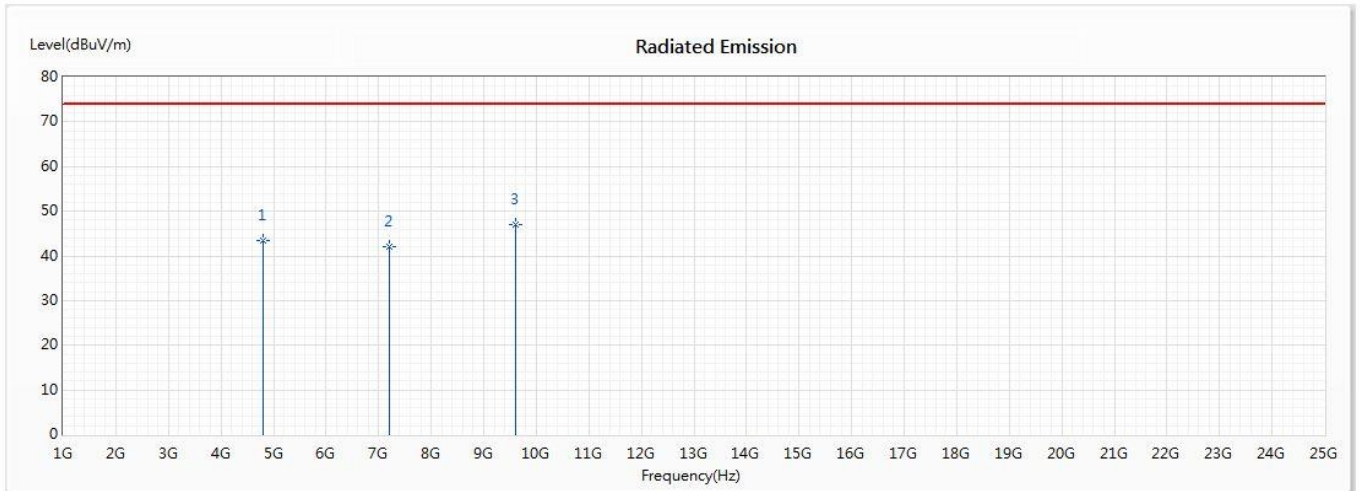

No	Frequency (MHz)	Emission Level (dBuV/m)	Limit (dBuV/m)	Margin (dB)	Reading Level (dBuV)	Correct Factor (dB/m)	Detector Type
1	4804	43.33	74.00	-30.67	55.48	-12.15	PK
2	7206	42.03	74.00	-31.97	55.17	-13.14	PK
* 3	9608	47.14	74.00	-26.86	60.56	-13.42	PK

Note:

1. All Readings below 1GHz are Quasi-Peak, above 1GHz are performed with peak and/or average measurements as necessary.
2. Peak measurements: RBW = 1MHz, VBW = 3 MHz, Sweep: Auto.
3. Average measurements: RBW = 1MHz, VBW = 10 Hz, Sweep: Auto.
4. Measurement Level = Reading Level + Correct Factor.
5. Correct Factor = Antenna factor + Cable loss – Amplifier gain.
6. The average measurement was not performed when the peak measured data under the limit of average detection.
7. The emission levels of other frequencies are very lower than the limit and not show in test report.

Product : WiFi SOM Module  
 Test Item : Harmonic Radiated Emission  
 Test Site : No.3 OATS  
 Test date : 2020/01/02  
 Test Mode : Mode 2: Bluetooth 2Mbps (2402MHz)

Vertical

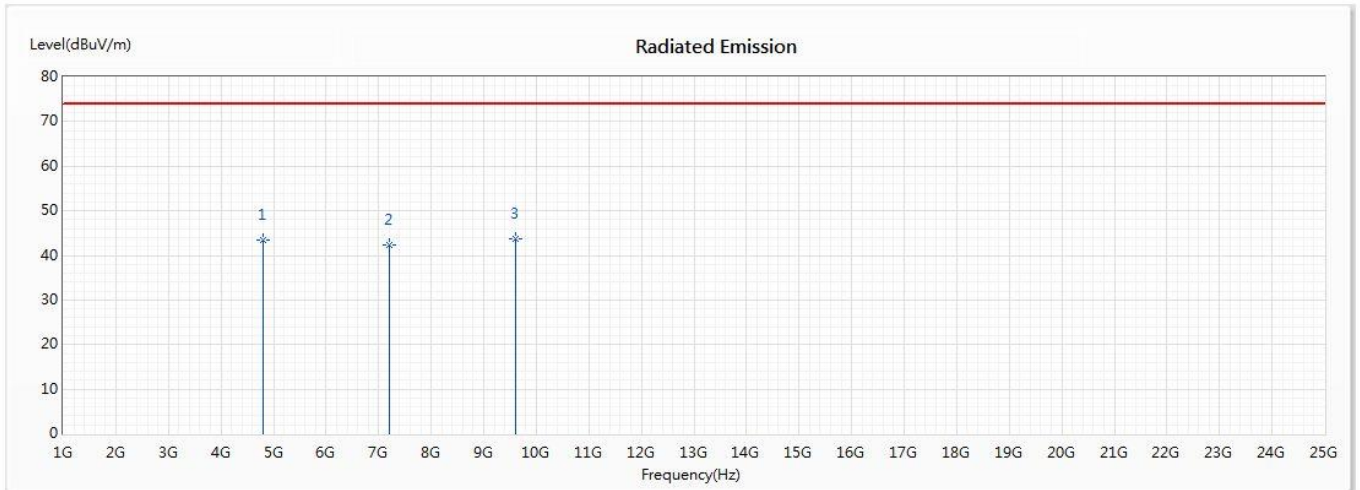

No	Frequency (MHz)	Emission Level (dBuV/m)	Limit (dBuV/m)	Margin (dB)	Reading Level (dBuV)	Correct Factor (dB/m)	Detector Type
1	4804	43.42	74.00	-30.58	55.57	-12.15	PK
2	7206	42.37	74.00	-31.63	55.51	-13.14	PK
* 3	9608	43.61	74.00	-30.39	57.03	-13.42	PK

Note:

1. All Readings below 1GHz are Quasi-Peak, above 1GHz are performed with peak and/or average measurements as necessary.
2. Peak measurements: RBW = 1MHz, VBW = 3 MHz, Sweep: Auto.
3. Average measurements: RBW = 1MHz, VBW = 10 Hz, Sweep: Auto.
4. Measurement Level = Reading Level + Correct Factor.
5. Correct Factor = Antenna factor + Cable loss – Amplifier gain.
6. The average measurement was not performed when the peak measured data under the limit of average detection.
7. The emission levels of other frequencies are very lower than the limit and not show in test report.



Product : WiFi SOM Module  
 Test Item : Harmonic Radiated Emission  
 Test Site : No.3 OATS  
 Test date : 2020/01/02  
 Test Mode : Mode 2: Bluetooth 2Mbps (2441MHz)

Horizontal

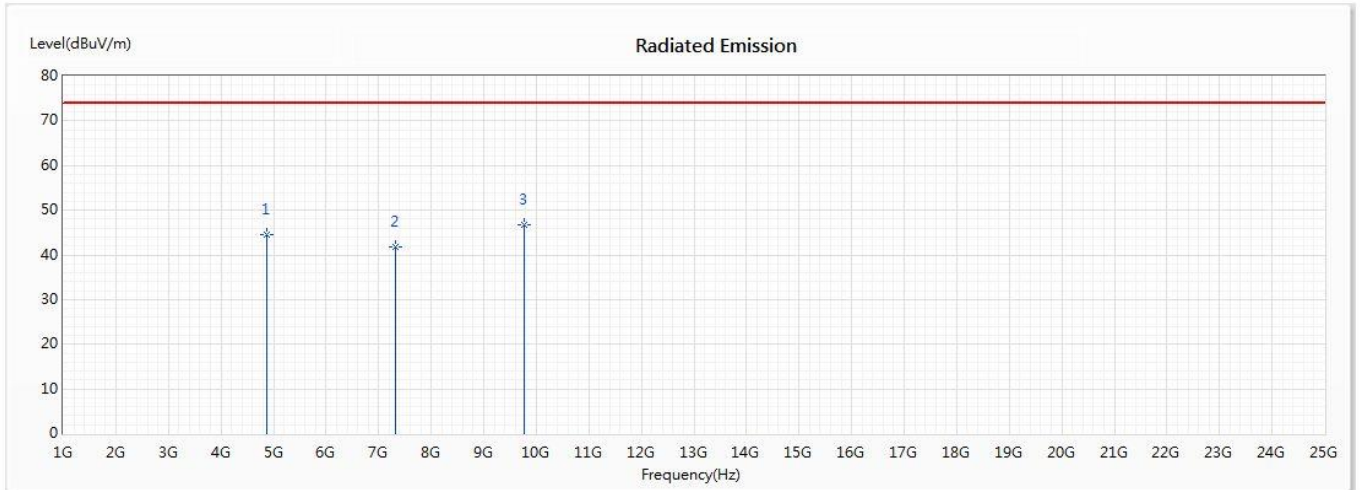

No	Frequency (MHz)	Emission Level (dBuV/m)	Limit (dBuV/m)	Margin (dB)	Reading Level (dBuV)	Correct Factor (dB/m)	Detector Type
1	4882	44.57	74.00	-29.43	56.16	-11.59	PK
2	7323	41.85	74.00	-32.15	55.42	-13.57	PK
* 3	9764	46.81	74.00	-27.19	59.33	-12.52	PK

Note:

1. All Readings below 1GHz are Quasi-Peak, above 1GHz are performed with peak and/or average measurements as necessary.
2. Peak measurements: RBW = 1MHz, VBW = 3 MHz, Sweep: Auto.
3. Average measurements: RBW = 1MHz, VBW = 10 Hz, Sweep: Auto.
4. Measurement Level = Reading Level + Correct Factor.
5. Correct Factor = Antenna factor + Cable loss – Amplifier gain.
6. The average measurement was not performed when the peak measured data under the limit of average detection.
7. The emission levels of other frequencies are very lower than the limit and not show in test report.

Product : WiFi SOM Module  
 Test Item : Harmonic Radiated Emission  
 Test Site : No.3 OATS  
 Test date : 2020/01/02  
 Test Mode : Mode 2: Bluetooth 2Mbps (2441MHz)

Vertical

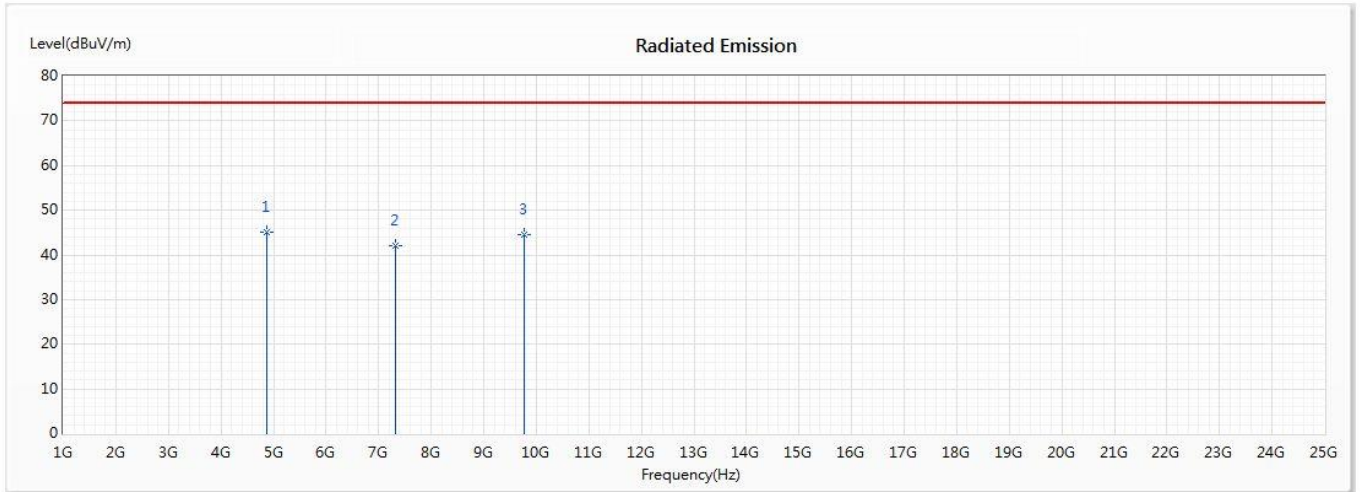

No	Frequency (MHz)	Emission Level (dBuV/m)	Limit (dBuV/m)	Margin (dB)	Reading Level (dBuV)	Correct Factor (dB/m)	Detector Type
* 1	4882	45.13	74.00	-28.87	56.72	-11.59	PK
2	7323	41.99	74.00	-32.01	55.56	-13.57	PK
3	9764	44.65	74.00	-29.35	57.17	-12.52	PK

Note:

- All Readings below 1GHz are Quasi-Peak, above 1GHz are performed with peak and/or average measurements as necessary.
- Peak measurements: RBW = 1MHz, VBW = 3 MHz, Sweep: Auto.
- Average measurements: RBW = 1MHz, VBW = 10 Hz, Sweep: Auto.
- Measurement Level = Reading Level + Correct Factor.
- Correct Factor = Antenna factor + Cable loss – Amplifier gain.
- The average measurement was not performed when the peak measured data under the limit of average detection.
- The emission levels of other frequencies are very lower than the limit and not show in test report.

Product : WiFi SOM Module  
 Test Item : Harmonic Radiated Emission  
 Test Site : No.3 OATS  
 Test date : 2020/01/02  
 Test Mode : Mode 2: Bluetooth 2Mbps (2480MHz)

Horizontal

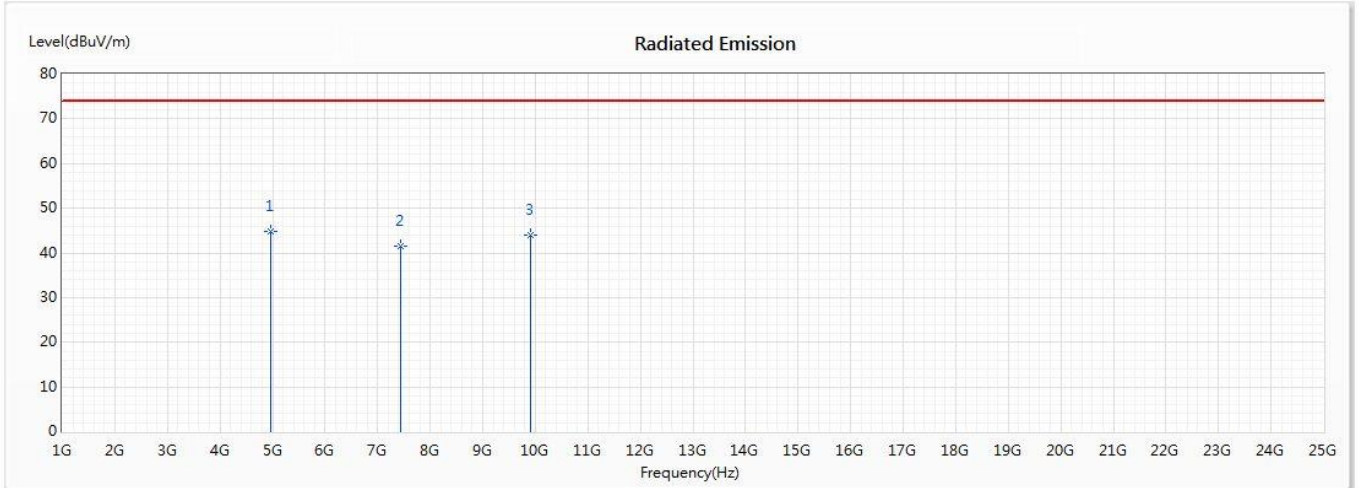

No	Frequency (MHz)	Emission Level (dBuV/m)	Limit (dBuV/m)	Margin (dB)	Reading Level (dBuV)	Correct Factor (dB/m)	Detector Type
* 1	4960	44.92	74.00	-29.08	55.81	-10.89	PK
2	7440	41.54	74.00	-32.46	56.16	-14.62	PK
3	9920	43.89	74.00	-30.11	58.12	-14.23	PK

Note:

1. All Readings below 1GHz are Quasi-Peak, above 1GHz are performed with peak and/or average measurements as necessary.
2. Peak measurements: RBW = 1MHz, VBW = 3 MHz, Sweep: Auto.
3. Average measurements: RBW = 1MHz, VBW = 10 Hz, Sweep: Auto.
4. Measurement Level = Reading Level + Correct Factor.
5. Correct Factor = Antenna factor + Cable loss – Amplifier gain.
6. The average measurement was not performed when the peak measured data under the limit of average detection.
7. The emission levels of other frequencies are very lower than the limit and not show in test report.

Product : WiFi SOM Module  
 Test Item : Harmonic Radiated Emission  
 Test Site : No.3 OATS  
 Test date : 2020/01/02  
 Test Mode : Mode 2: Bluetooth 2Mbps (2480MHz)

Vertical

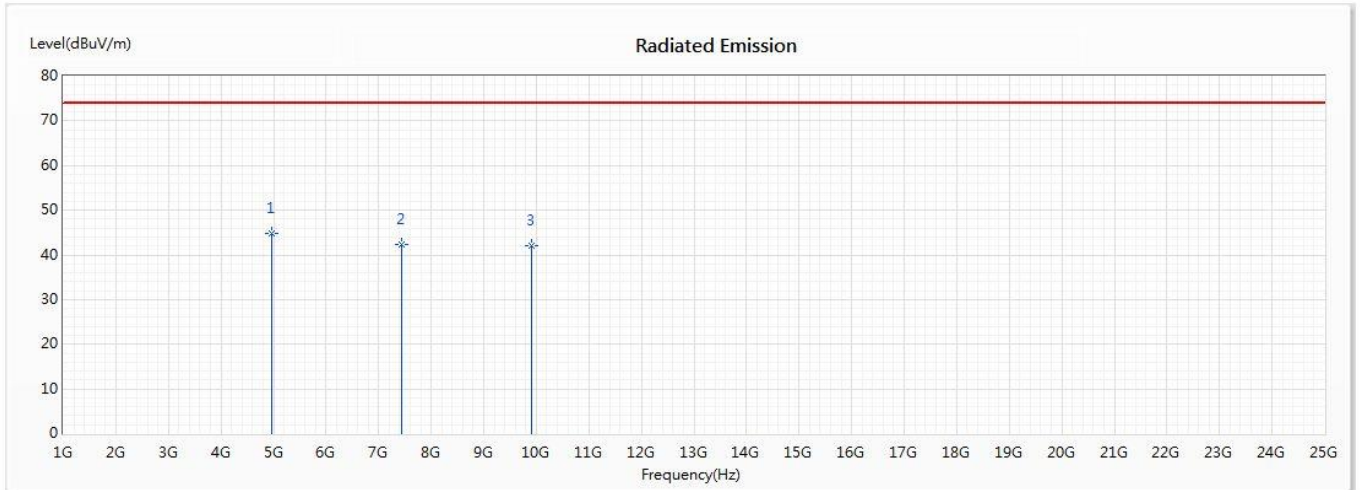

No	Frequency (MHz)	Emission Level (dBuV/m)	Limit (dBuV/m)	Margin (dB)	Reading Level (dBuV)	Correct Factor (dB/m)	Detector Type
* 1	4960	44.82	74.00	-29.18	55.71	-10.89	PK
2	7440	42.27	74.00	-31.73	56.89	-14.62	PK
3	9920	42.18	74.00	-31.82	56.41	-14.23	PK

Note:

1. All Readings below 1GHz are Quasi-Peak, above 1GHz are performed with peak and/or average measurements as necessary.
2. Peak measurements: RBW = 1MHz, VBW = 3 MHz, Sweep: Auto.
3. Average measurements: RBW = 1MHz, VBW = 10 Hz, Sweep: Auto.
4. Measurement Level = Reading Level + Correct Factor.
5. Correct Factor = Antenna factor + Cable loss – Amplifier gain.
6. The average measurement was not performed when the peak measured data under the limit of average detection.
7. The emission levels of other frequencies are very lower than the limit and not show in test report.

Product : WiFi SOM Module  
 Test Item : Harmonic Radiated Emission  
 Test Site : No.3 OATS  
 Test date : 2020/01/02  
 Test Mode : Mode 3: Bluetooth 3Mbps (2402MHz)

Horizontal

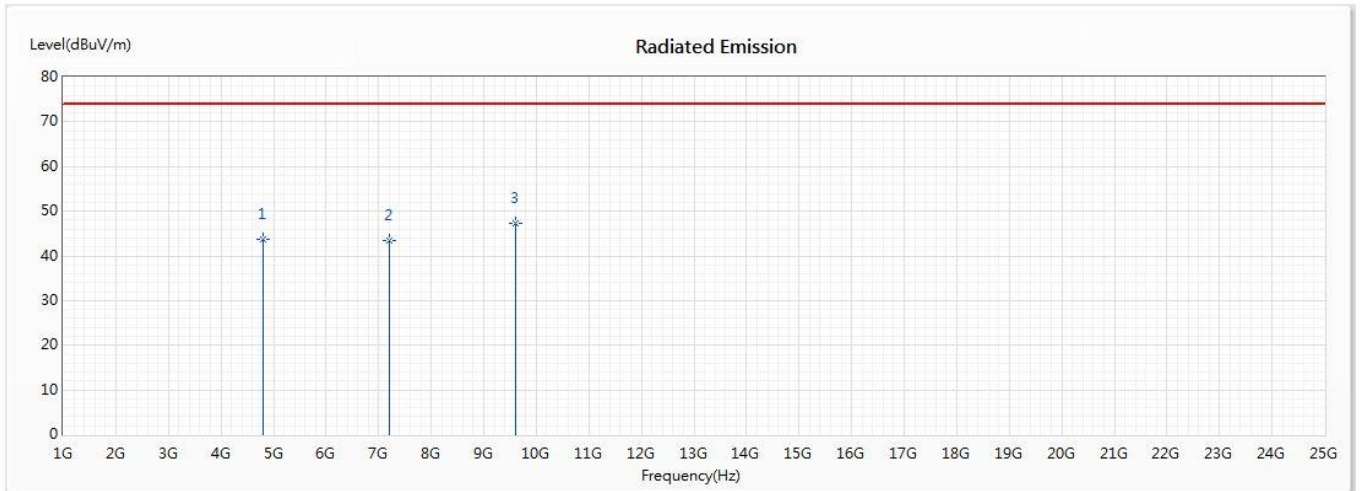

No	Frequency (MHz)	Emission Level (dBuV/m)	Limit (dBuV/m)	Margin (dB)	Reading Level (dBuV)	Correct Factor (dB/m)	Detector Type
1	4804	43.70	74.00	-30.30	55.85	-12.15	PK
2	7206	43.33	74.00	-30.67	56.47	-13.14	PK
* 3	9608	47.34	74.00	-26.66	60.76	-13.42	PK

Note:

1. All Readings below 1GHz are Quasi-Peak, above 1GHz are performed with peak and/or average measurements as necessary.
2. Peak measurements: RBW = 1MHz, VBW = 3 MHz, Sweep: Auto.
3. Average measurements: RBW = 1MHz, VBW = 10 Hz, Sweep: Auto.
4. Measurement Level = Reading Level + Correct Factor.
5. Correct Factor = Antenna factor + Cable loss – Amplifier gain.
6. The average measurement was not performed when the peak measured data under the limit of average detection.
7. The emission levels of other frequencies are very lower than the limit and not show in test report.

Product : WiFi SOM Module  
 Test Item : Harmonic Radiated Emission  
 Test Site : No.3 OATS  
 Test date : 2020/01/02  
 Test Mode : Mode 3: Bluetooth 3Mbps (2402MHz)

Vertical

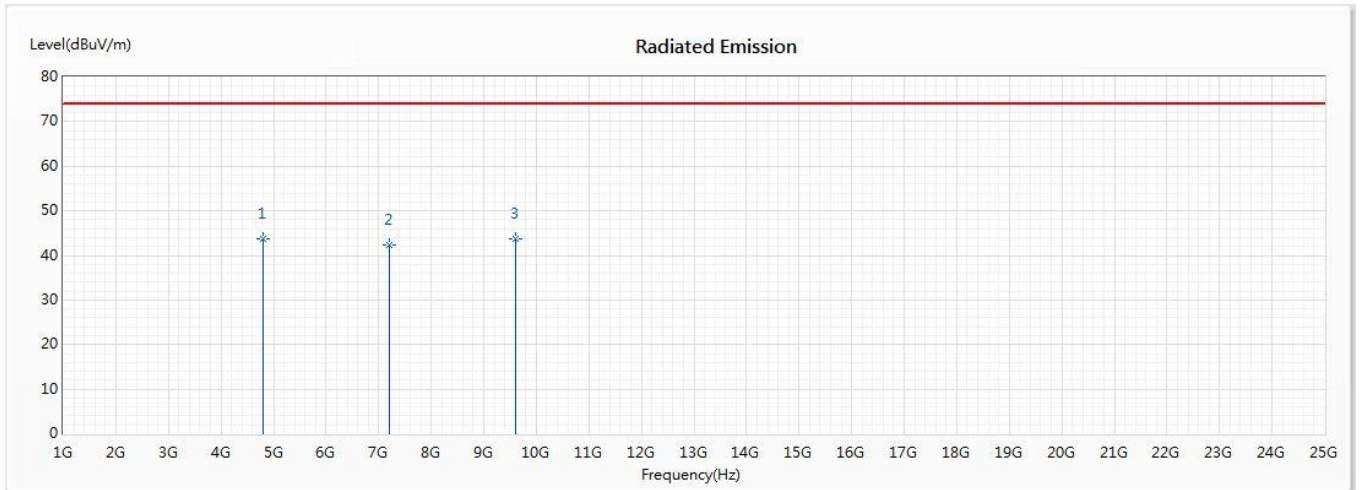

No	Frequency (MHz)	Emission Level (dBuV/m)	Limit (dBuV/m)	Margin (dB)	Reading Level (dBuV)	Correct Factor (dB/m)	Detector Type
1	4804	43.58	74.00	-30.42	55.73	-12.15	PK
2	7206	42.42	74.00	-31.58	55.56	-13.14	PK
* 3	9608	43.82	74.00	-30.18	57.24	-13.42	PK

Note:

1. All Readings below 1GHz are Quasi-Peak, above 1GHz are performed with peak and/or average measurements as necessary.
2. Peak measurements: RBW = 1MHz, VBW = 3 MHz, Sweep: Auto.
3. Average measurements: RBW = 1MHz, VBW = 10 Hz, Sweep: Auto.
4. Measurement Level = Reading Level + Correct Factor.
5. Correct Factor = Antenna factor + Cable loss – Amplifier gain.
6. The average measurement was not performed when the peak measured data under the limit of average detection.
7. The emission levels of other frequencies are very lower than the limit and not show in test report.



Product : WiFi SOM Module  
 Test Item : Harmonic Radiated Emission  
 Test Site : No.3 OATS  
 Test date : 2020/01/02  
 Test Mode : Mode 3: Bluetooth 3Mbps (2441MHz)

Horizontal

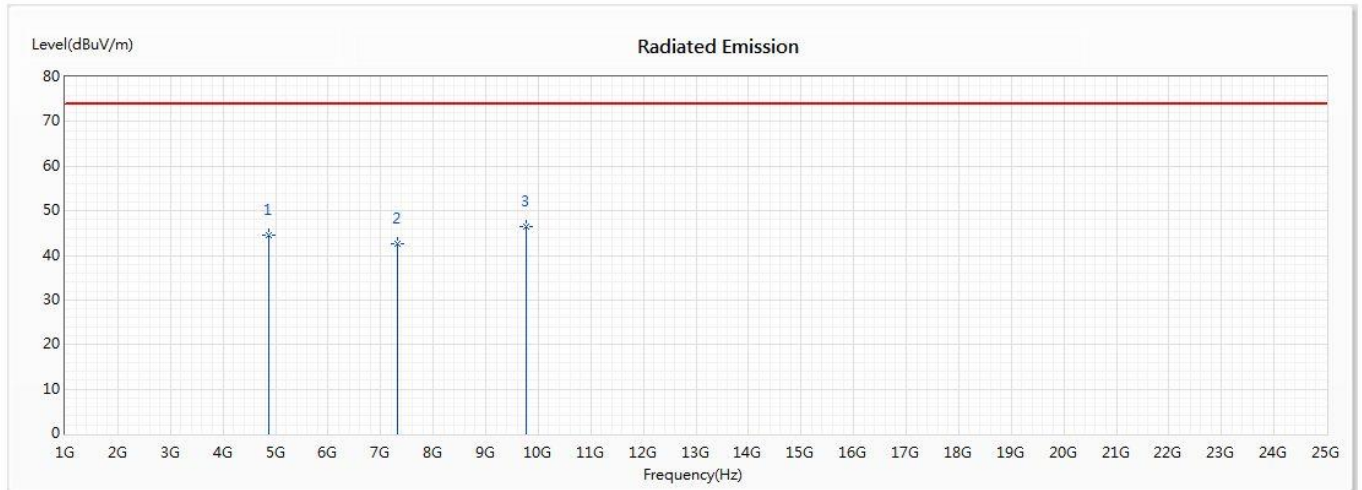

No	Frequency (MHz)	Emission Level (dBuV/m)	Limit (dBuV/m)	Margin (dB)	Reading Level (dBuV)	Correct Factor (dB/m)	Detector Type
1	4882	44.45	74.00	-29.55	56.04	-11.59	PK
2	7323	42.60	74.00	-31.40	56.17	-13.57	PK
* 3	9764	46.52	74.00	-27.48	59.04	-12.52	PK

Note:

1. All Readings below 1GHz are Quasi-Peak, above 1GHz are performed with peak and/or average measurements as necessary.
2. Peak measurements: RBW = 1MHz, VBW = 3 MHz, Sweep: Auto.
3. Average measurements: RBW = 1MHz, VBW = 10 Hz, Sweep: Auto.
4. Measurement Level = Reading Level + Correct Factor.
5. Correct Factor = Antenna factor + Cable loss – Amplifier gain.
6. The average measurement was not performed when the peak measured data under the limit of average detection.
7. The emission levels of other frequencies are very lower than the limit and not show in test report.

Product : WiFi SOM Module  
 Test Item : Harmonic Radiated Emission  
 Test Site : No.3 OATS  
 Test date : 2020/01/02  
 Test Mode : Mode 3: Bluetooth 3Mbps (2441MHz)

Vertical

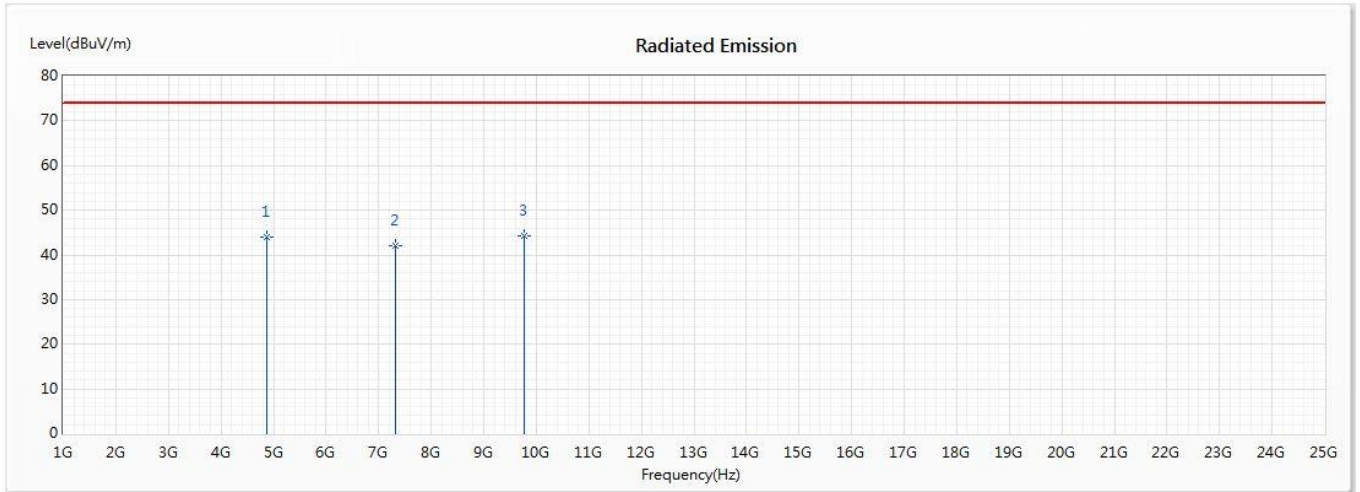

No	Frequency (MHz)	Emission Level (dBuV/m)	Limit (dBuV/m)	Margin (dB)	Reading Level (dBuV)	Correct Factor (dB/m)	Detector Type
1	4882	44.02	74.00	-29.98	55.61	-11.59	PK
2	7323	42.16	74.00	-31.84	55.73	-13.57	PK
* 3	9764	44.23	74.00	-29.77	56.75	-12.52	PK

Note:

1. All Readings below 1GHz are Quasi-Peak, above 1GHz are performed with peak and/or average measurements as necessary.
2. Peak measurements: RBW = 1MHz, VBW = 3 MHz, Sweep: Auto.
3. Average measurements: RBW = 1MHz, VBW = 10 Hz, Sweep: Auto.
4. Measurement Level = Reading Level + Correct Factor.
5. Correct Factor = Antenna factor + Cable loss – Amplifier gain.
6. The average measurement was not performed when the peak measured data under the limit of average detection.
7. The emission levels of other frequencies are very lower than the limit and not show in test report.



Product : WiFi SOM Module  
 Test Item : Harmonic Radiated Emission  
 Test Site : No.3 OATS  
 Test date : 2020/01/02  
 Test Mode : Mode 3: Bluetooth 3Mbps (2480MHz)

Horizontal

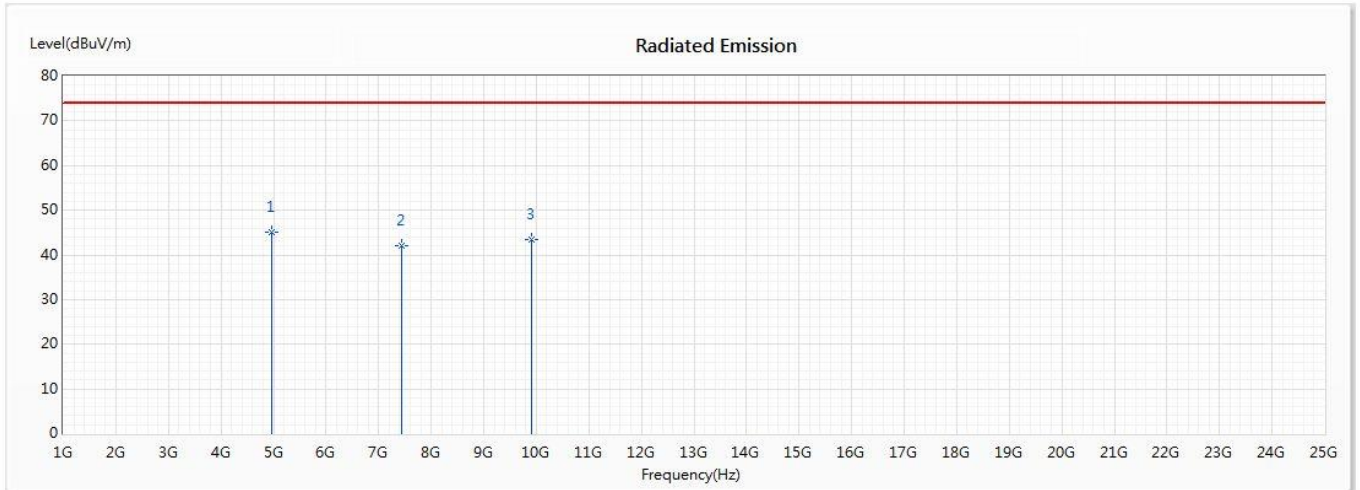

No	Frequency (MHz)	Emission Level (dBuV/m)	Limit (dBuV/m)	Margin (dB)	Reading Level (dBuV)	Correct Factor (dB/m)	Detector Type
* 1	4960	44.96	74.00	-29.04	55.85	-10.89	PK
2	7440	42.02	74.00	-31.98	56.64	-14.62	PK
3	9920	43.57	74.00	-30.43	57.80	-14.23	PK

Note:

1. All Readings below 1GHz are Quasi-Peak, above 1GHz are performed with peak and/or average measurements as necessary.
2. Peak measurements: RBW = 1MHz, VBW = 3 MHz, Sweep: Auto.
3. Average measurements: RBW = 1MHz, VBW = 10 Hz, Sweep: Auto.
4. Measurement Level = Reading Level + Correct Factor.
5. Correct Factor = Antenna factor + Cable loss – Amplifier gain.
6. The average measurement was not performed when the peak measured data under the limit of average detection.
7. The emission levels of other frequencies are very lower than the limit and not show in test report.

Product : WiFi SOM Module  
 Test Item : Harmonic Radiated Emission  
 Test Site : No.3 OATS  
 Test date : 2020/01/02  
 Test Mode : Mode 3: Bluetooth 3Mbps (2480MHz)

Vertical

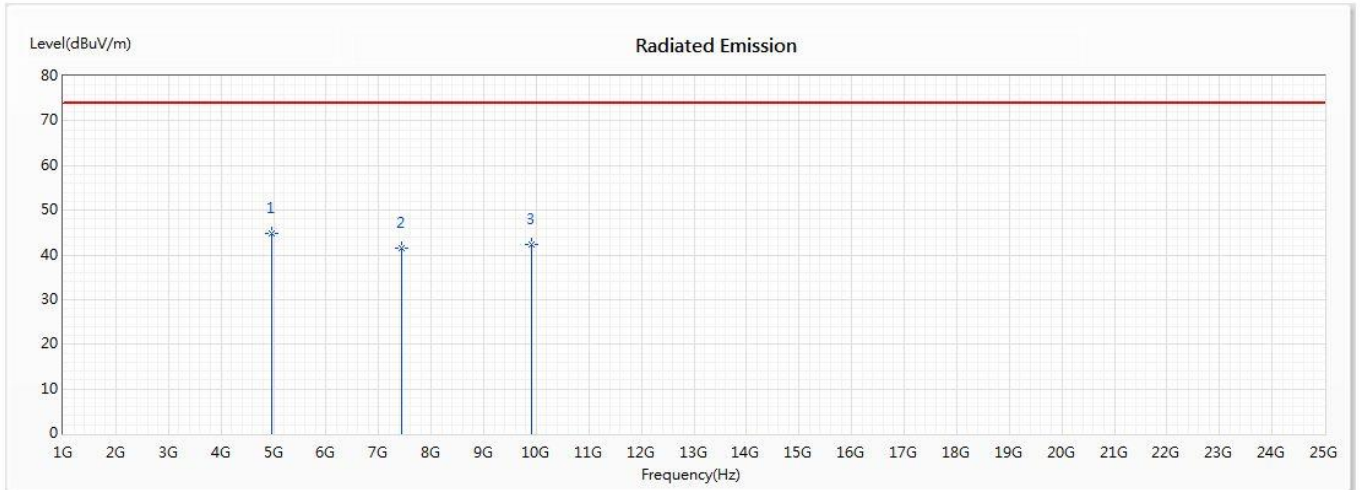

No	Frequency (MHz)	Emission Level (dBuV/m)	Limit (dBuV/m)	Margin (dB)	Reading Level (dBuV)	Correct Factor (dB/m)	Detector Type
* 1	4960	44.79	74.00	-29.21	55.68	-10.89	PK
2	7440	41.64	74.00	-32.36	56.26	-14.62	PK
3	9920	42.45	74.00	-31.55	56.68	-14.23	PK

Note:

1. All Readings below 1GHz are Quasi-Peak, above 1GHz are performed with peak and/or average measurements as necessary.
2. Peak measurements: RBW = 1MHz, VBW = 3 MHz, Sweep: Auto.
3. Average measurements: RBW = 1MHz, VBW = 10 Hz, Sweep: Auto.
4. Measurement Level = Reading Level + Correct Factor.
5. Correct Factor = Antenna factor + Cable loss – Amplifier gain.
6. The average measurement was not performed when the peak measured data under the limit of average detection.
7. The emission levels of other frequencies are very lower than the limit and not show in test report.

Product : WiFi SOM Module  
 Test Item : General Radiated Emission  
 Test Site : No.3 OATS  
 Test date : 2020/01/02  
 Test Mode : Mode 1: Bluetooth 1Mbps (2441MHz)

Horizontal

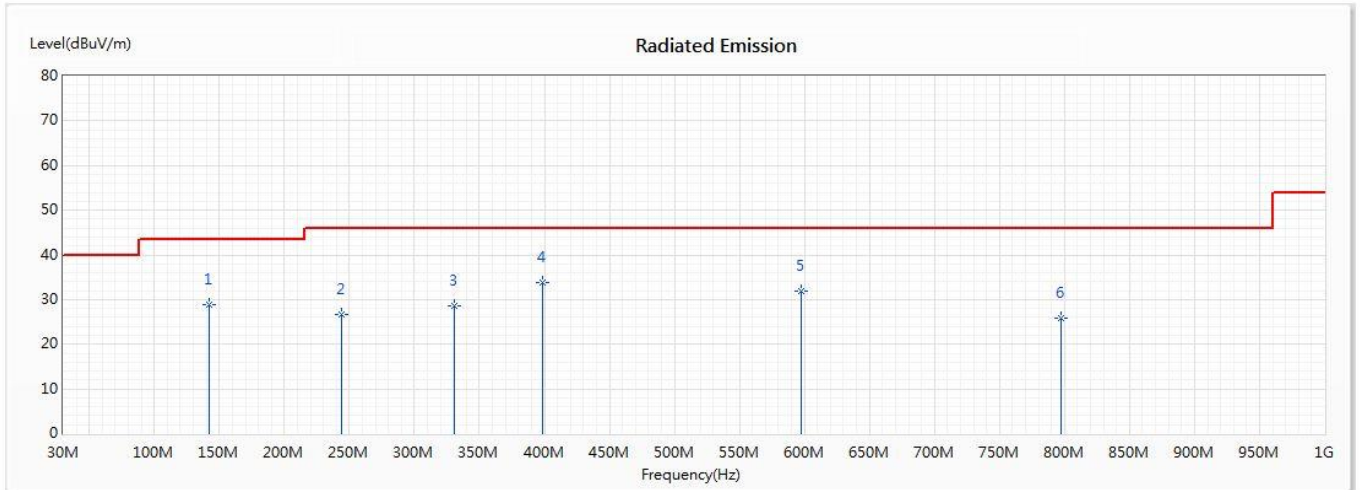

No	Frequency (MHz)	Emission Level (dBuV/m)	Limit (dBuV/m)	Margin (dB)	Reading Level (dBuV)	Correct Factor (dB/m)	Detector Type
1	142.464	28.81	43.50	-14.69	46.98	-18.17	QP
2	243.681	26.63	46.00	-19.37	44.97	-18.34	QP
3	330.841	28.67	46.00	-17.33	42.68	-14.01	QP
* 4	398.319	33.81	46.00	-12.19	47.36	-13.55	QP
5	597.942	31.84	46.00	-14.16	38.54	-6.70	QP
6	797.565	25.86	46.00	-20.14	34.75	-8.89	QP

Note:

1. All Readings below 1GHz are Quasi-Peak, above 1GHz are performed with peak and/or average measurements as necessary.
2. Peak measurements: RBW = 1MHz, VBW = 3 MHz, Sweep: Auto.
3. Average measurements: RBW = 1MHz, VBW = 10 Hz, Sweep: Auto.
4. Measurement Level = Reading Level + Correct Factor.
5. Correct Factor = Antenna factor + Cable loss – Amplifier gain.
6. The average measurement was not performed when the peak measured data under the limit of average detection.
7. The emission levels of other frequencies are very lower than the limit and not show in test report.

Product : WiFi SOM Module  
 Test Item : General Radiated Emission  
 Test Site : No.3 OATS  
 Test date : 2020/01/02  
 Test Mode : Mode 1: Bluetooth 1Mbps (2441MHz)

Vertical

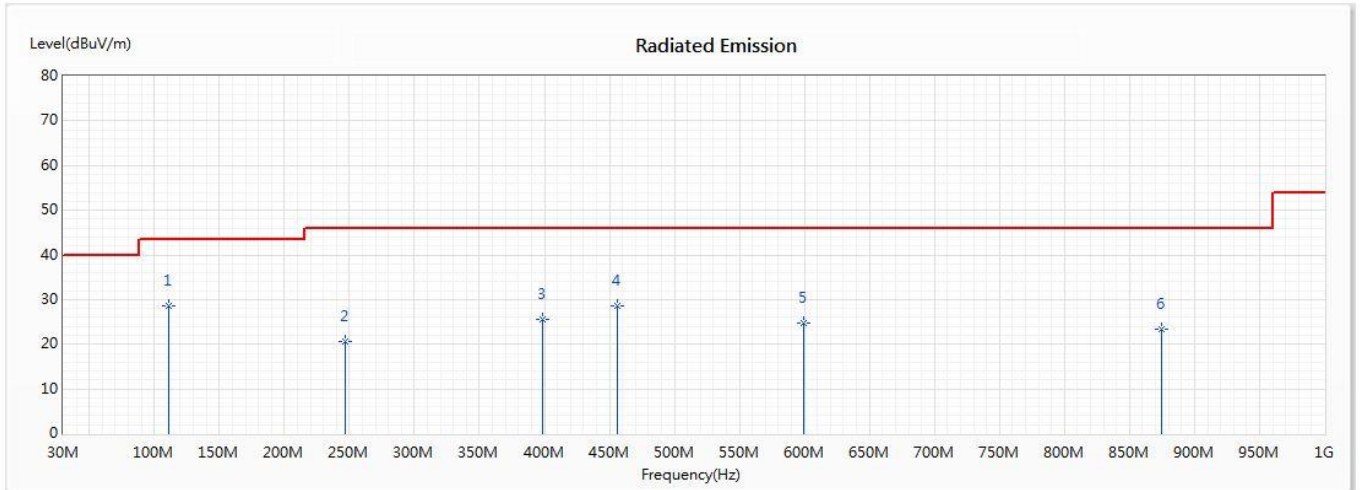

No	Frequency (MHz)	Emission Level (dBuV/m)	Limit (dBuV/m)	Margin (dB)	Reading Level (dBuV)	Correct Factor (dB/m)	Detector Type
* 1	111.536	28.61	43.50	-14.89	45.43	-16.82	QP
2	246.493	20.73	46.00	-25.27	38.88	-18.15	QP
3	398.319	25.68	46.00	-20.32	39.23	-13.55	QP
4	455.957	28.55	46.00	-17.45	38.90	-10.35	QP
5	599.348	24.75	46.00	-21.25	31.38	-6.63	QP
6	874.884	23.37	46.00	-22.63	31.77	-8.40	QP

Note:

1. All Readings below 1GHz are Quasi-Peak, above 1GHz are performed with peak and/or average measurements as necessary.
2. Peak measurements: RBW = 1MHz, VBW = 3 MHz, Sweep: Auto.
3. Average measurements: RBW = 1MHz, VBW = 10 Hz, Sweep: Auto.
4. Measurement Level = Reading Level + Correct Factor.
5. Correct Factor = Antenna factor + Cable loss – Amplifier gain.
6. The average measurement was not performed when the peak measured data under the limit of average detection.
7. The emission levels of other frequencies are very lower than the limit and not show in test report.

Product : WiFi SOM Module  
 Test Item : General Radiated Emission  
 Test Site : No.3 OATS  
 Test date : 2020/01/02  
 Test Mode : Mode 2: Bluetooth 2Mbps (2441MHz)

Horizontal

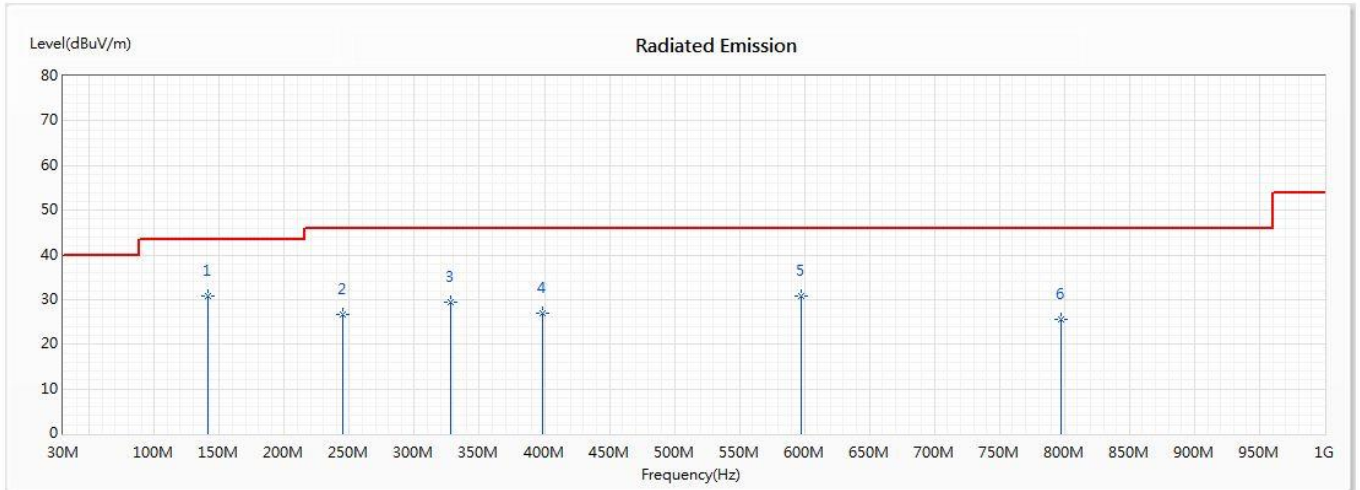

No	Frequency (MHz)	Emission Level (dBuV/m)	Limit (dBuV/m)	Margin (dB)	Reading Level (dBuV)	Correct Factor (dB/m)	Detector Type
* 1	141.058	30.70	43.50	-12.80	48.55	-17.85	QP
2	245.087	26.59	46.00	-19.41	44.83	-18.24	QP
3	328.029	29.49	46.00	-16.51	43.51	-14.02	QP
4	398.319	26.95	46.00	-19.05	40.50	-13.55	QP
5	597.942	30.80	46.00	-15.20	37.50	-6.70	QP
6	797.565	25.52	46.00	-20.48	34.41	-8.89	QP

Note:

1. All Readings below 1GHz are Quasi-Peak, above 1GHz are performed with peak and/or average measurements as necessary.
2. Peak measurements: RBW = 1MHz, VBW = 3 MHz, Sweep: Auto.
3. Average measurements: RBW = 1MHz, VBW = 10 Hz, Sweep: Auto.
4. Measurement Level = Reading Level + Correct Factor.
5. Correct Factor = Antenna factor + Cable loss – Amplifier gain.
6. The average measurement was not performed when the peak measured data under the limit of average detection.
7. The emission levels of other frequencies are very lower than the limit and not show in test report.

Product : WiFi SOM Module  
 Test Item : General Radiated Emission  
 Test Site : No.3 OATS  
 Test date : 2020/01/02  
 Test Mode : Mode 2: Bluetooth 2Mbps (2441MHz)

Vertical

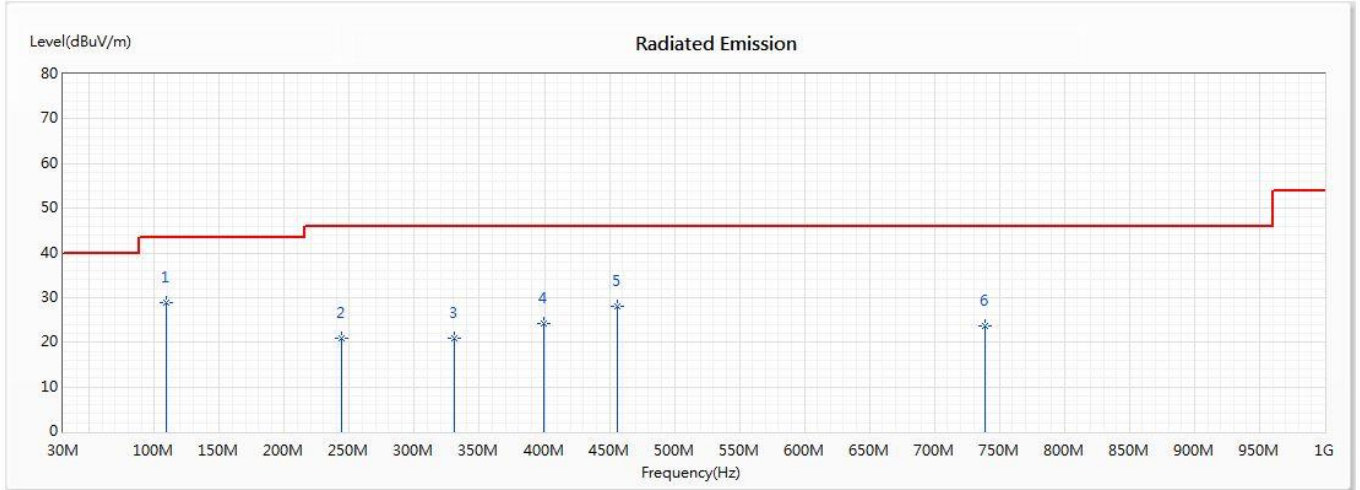

No	Frequency (MHz)	Emission Level (dBuV/m)	Limit (dBuV/m)	Margin (dB)	Reading Level (dBuV)	Correct Factor (dB/m)	Detector Type
* 1	108.725	28.91	43.50	-14.59	45.61	-16.70	QP
2	243.681	20.78	46.00	-25.22	39.12	-18.34	QP
3	330.841	20.99	46.00	-25.01	35.00	-14.01	QP
4	399.725	24.17	46.00	-21.83	37.84	-13.67	QP
5	455.957	28.17	46.00	-17.83	38.52	-10.35	QP
6	738.522	23.56	46.00	-22.44	29.31	-5.75	QP

Note:

1. All Readings below 1GHz are Quasi-Peak, above 1GHz are performed with peak and/or average measurements as necessary.
2. Peak measurements: RBW = 1MHz, VBW = 3 MHz, Sweep: Auto.
3. Average measurements: RBW = 1MHz, VBW = 10 Hz, Sweep: Auto.
4. Measurement Level = Reading Level + Correct Factor.
5. Correct Factor = Antenna factor + Cable loss – Amplifier gain.
6. The average measurement was not performed when the peak measured data under the limit of average detection.
7. The emission levels of other frequencies are very lower than the limit and not show in test report.



Product : WiFi SOM Module  
 Test Item : General Radiated Emission  
 Test Site : No.3 OATS  
 Test date : 2020/01/02  
 Test Mode : Mode 3: Bluetooth 3Mbps (2441MHz)

Horizontal

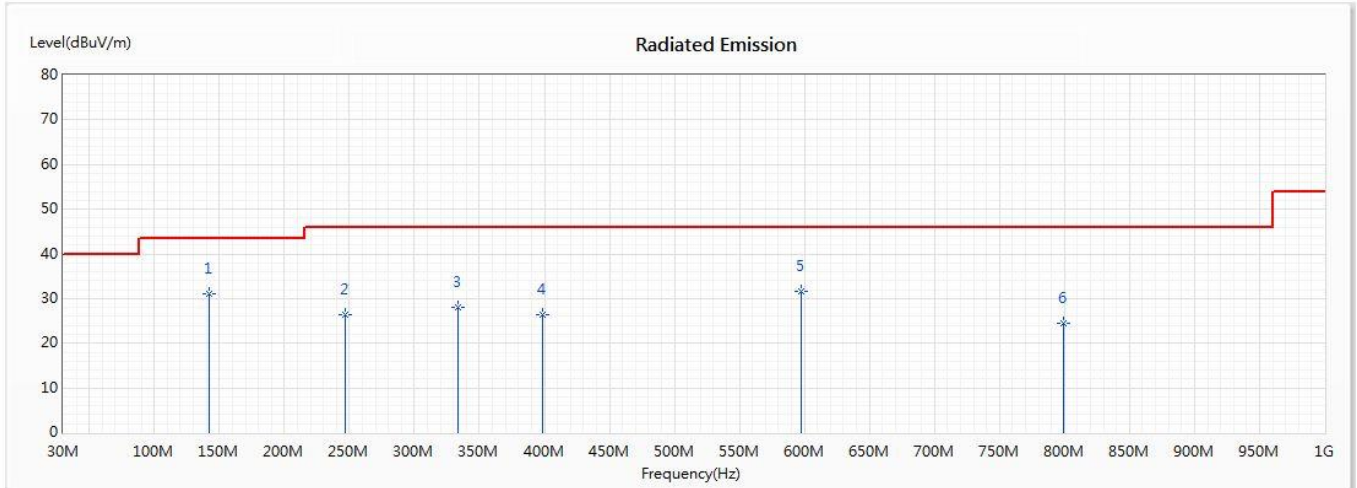

No	Frequency (MHz)	Emission Level (dBuV/m)	Limit (dBuV/m)	Margin (dB)	Reading Level (dBuV)	Correct Factor (dB/m)	Detector Type
* 1	142.464	30.93	43.50	-12.57	49.10	-18.17	QP
2	246.493	26.29	46.00	-19.71	44.44	-18.15	QP
3	333.652	27.94	46.00	-18.06	41.93	-13.99	QP
4	398.319	26.35	46.00	-19.65	39.90	-13.55	QP
5	597.942	31.50	46.00	-14.50	38.20	-6.70	QP
6	798.971	24.39	46.00	-21.61	33.30	-8.91	QP

Note:

1. All Readings below 1GHz are Quasi-Peak, above 1GHz are performed with peak and/or average measurements as necessary.
2. Peak measurements: RBW = 1MHz, VBW = 3 MHz, Sweep: Auto.
3. Average measurements: RBW = 1MHz, VBW = 10 Hz, Sweep: Auto.
4. Measurement Level = Reading Level + Correct Factor.
5. Correct Factor = Antenna factor + Cable loss – Amplifier gain.
6. The average measurement was not performed when the peak measured data under the limit of average detection.
7. The emission levels of other frequencies are very lower than the limit and not show in test report.

Product : WiFi SOM Module  
 Test Item : General Radiated Emission  
 Test Site : No.3 OATS  
 Test date : 2020/01/02  
 Test Mode : Mode 3: Bluetooth 3Mbps (2441MHz)

Vertical

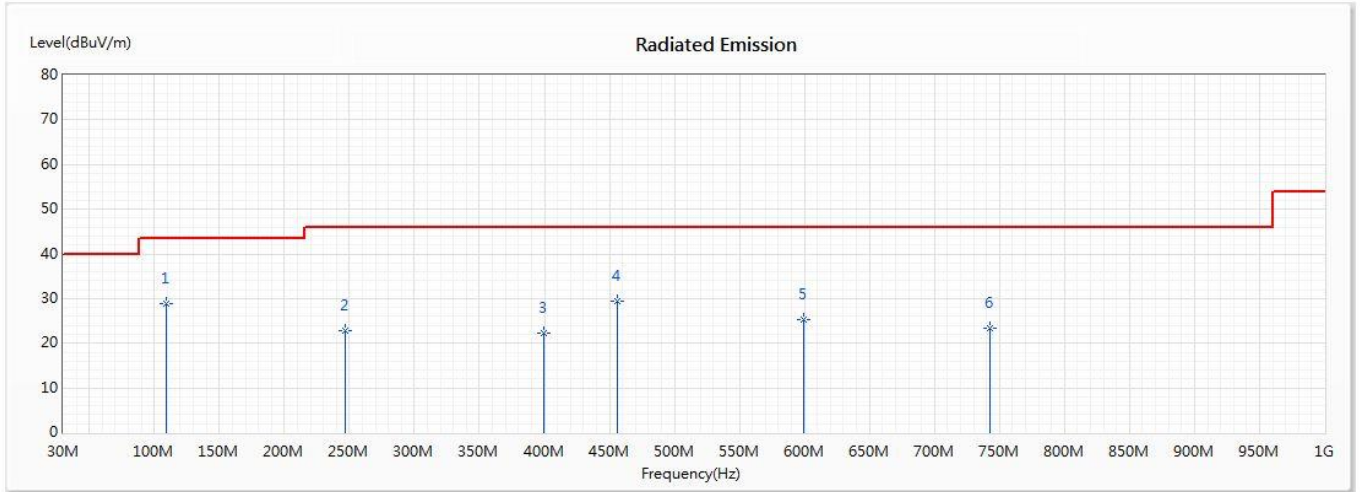

No	Frequency (MHz)	Emission Level (dBuV/m)	Limit (dBuV/m)	Margin (dB)	Reading Level (dBuV)	Correct Factor (dB/m)	Detector Type
* 1	108.725	29.00	43.50	-14.50	45.70	-16.70	QP
2	246.493	22.71	46.00	-23.29	40.86	-18.15	QP
3	399.725	22.24	46.00	-23.76	35.91	-13.67	QP
4	455.957	29.42	46.00	-16.58	39.77	-10.35	QP
5	599.348	25.36	46.00	-20.64	31.99	-6.63	QP
6	742.739	23.46	46.00	-22.54	29.28	-5.82	QP

Note:

1. All Readings below 1GHz are Quasi-Peak, above 1GHz are performed with peak and/or average measurements as necessary.
2. Peak measurements: RBW = 1MHz, VBW = 3 MHz, Sweep: Auto.
3. Average measurements: RBW = 1MHz, VBW = 10 Hz, Sweep: Auto.
4. Measurement Level = Reading Level + Correct Factor.
5. Correct Factor = Antenna factor + Cable loss – Amplifier gain.
6. The average measurement was not performed when the peak measured data under the limit of average detection.
7. The emission levels of other frequencies are very lower than the limit and not show in test report.



## 4. Band Edge

### 4.1. Test Setup

#### RF Conducted Measurement

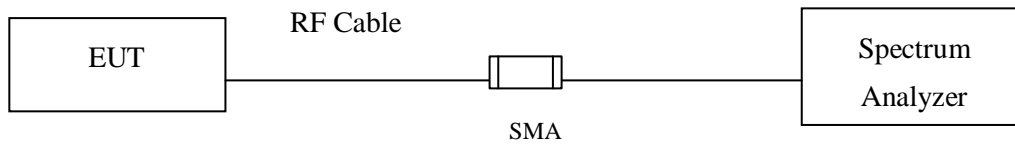

#### RF Radiated Measurement:

Above 1GHz

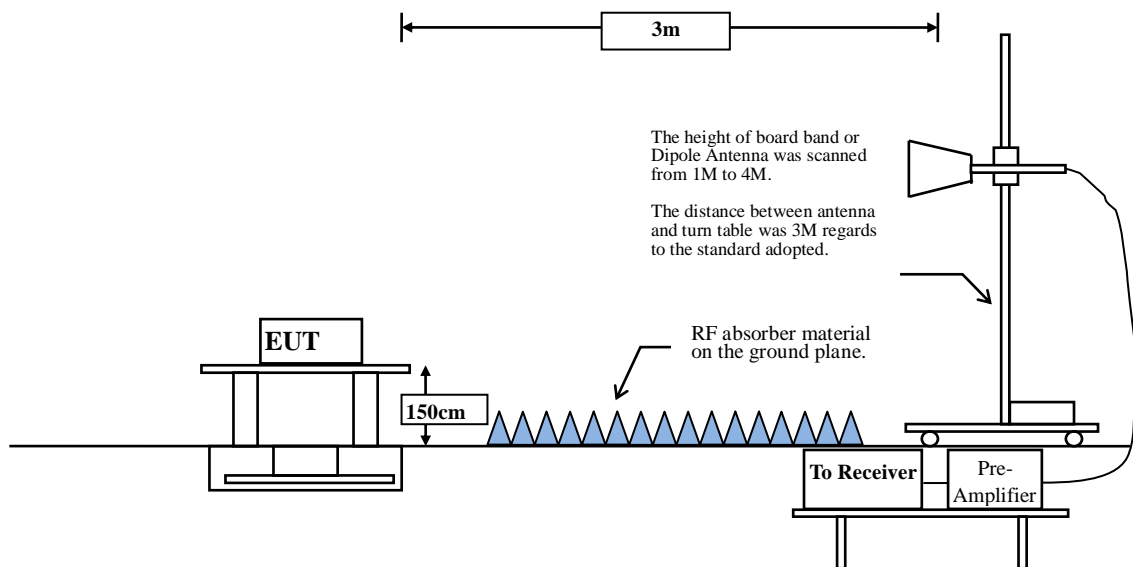

## 4.2. Limit

In any 100 kHz bandwidth outside the frequency band in which the spread spectrum intentional radiator is operating, the radio frequency power that is produced by the intentional radiator shall be at least 20 dB below that in the 100 kHz bandwidth within the band that contains the highest level of the desired power, based on either an RF conducted or a radiated measurement. Attenuation below the general limits specified in Section 15.209(a) is not required. In addition, radiated emissions which fall in the restricted bands, as defined in Section 15.205(a), must also comply with the radiated emission limits specified in Section 15.209(a) (see Section 15.205(c)).

## 4.3. Test Procedure

The EUT is placed on a turn table which is 1.5 meter above ground. The turn table is rotated 360 degrees to determine the position of the maximum emission level. The EUT was positioned such that the distance from antenna to the EUT was 3 meters.

The antenna can move up and down between 1 meter and 4 meters to find out the maximum emission level.

Both horizontal and vertical polarization of the antenna are set on measurement. In order to find the maximum emission, all of the interface cables must be manipulated according to ANSI C63.10: 2013 on radiated measurement.

The bandwidth setting below 1GHz and above 1GHz on the field strength meter is 120 kHz and 1MHz, respectively.

## 4.4. Uncertainty

± 4.08 dB above 1GHz

± 4.22 dB below 1GHz

### 4.5. Test Result of Band Edge

Product : WiFi SOM Module  
 Test Item : Band Edge  
 Test Site : No.3 OATS  
 Test date : 2019/12/27  
 Test Mode : Mode 1: Bluetooth 1Mbps (2402MHz)

Horizontal

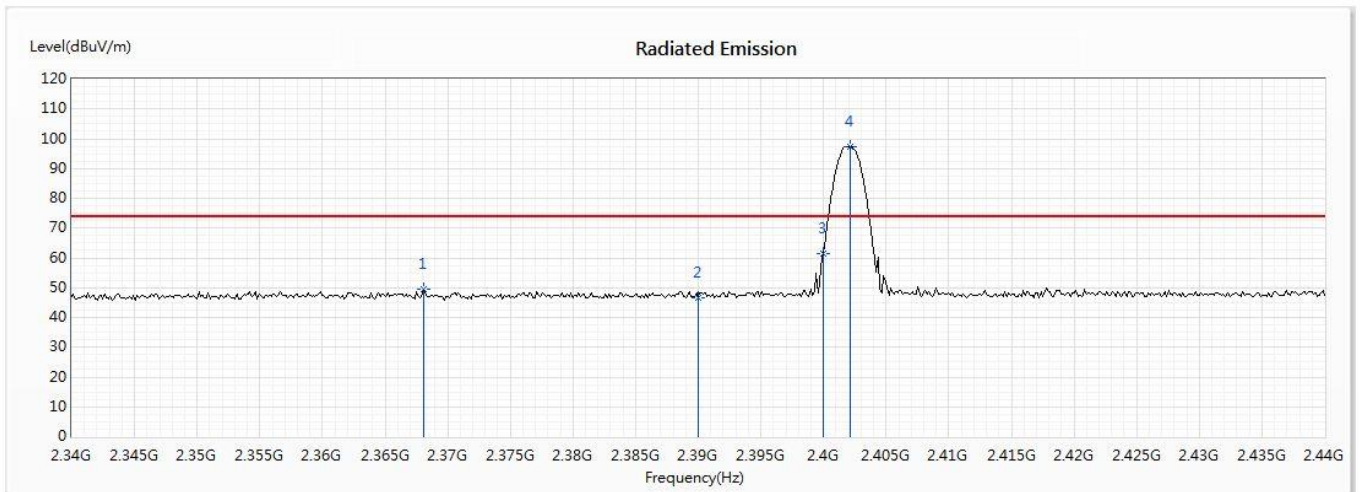

No	Frequency (MHz)	Emission Level (dBuV/m)	Limit (dBuV/m)	Margin (dB)	Reading Level (dBuV)	Correct Factor (dB/m)	Detector Type
1	2368.116	49.56	74.00	-24.44	36.78	12.78	PK
2	2390	46.80	74.00	-27.20	33.91	12.89	PK
3	2400	61.54	--	--	48.58	12.96	PK
! 4	2402.174	97.33	--	--	84.36	12.97	PK

Note:

1. All readings above 1GHz are performed with peak and/or average measurements as necessary.
2. Peak measurements: RBW = 1MHz, VBW = 3 MHz, Sweep: Auto.
3. Measurement Level = Reading Level + Correct Factor.
4. The average measurement was not performed when the peak measured data under the limit of average detection.

Channel No.	Frequency (MHz)	Peak Measurement (dBμV/m)	Duty Cycle Factor (dB)	Average Measurement (dBμV/m)	Average Limit (dBμV/m)	Result
00 (Average)	2368.116	49.56	-30.755	18.805	54.000	Pass
00 (Average)	2390	46.8	-30.755	16.045	54.000	Pass
00 (Average)	2400	61.54	-30.755	30.785	--	Pass
00 (Average)	2402.174	97.33	-30.755	66.575	--	Pass

Note:

1. Average Measurement=Peak Measurement + Duty Cycle Factor
2. The Duty Cycle is refer to section 5.

Product : WiFi SOM Module  
 Test Item : Band Edge  
 Test Site : No.3 OATS  
 Test date : 2019/12/27  
 Test Mode : Mode 1: Bluetooth 1Mbps (2402MHz)

VERTICAL

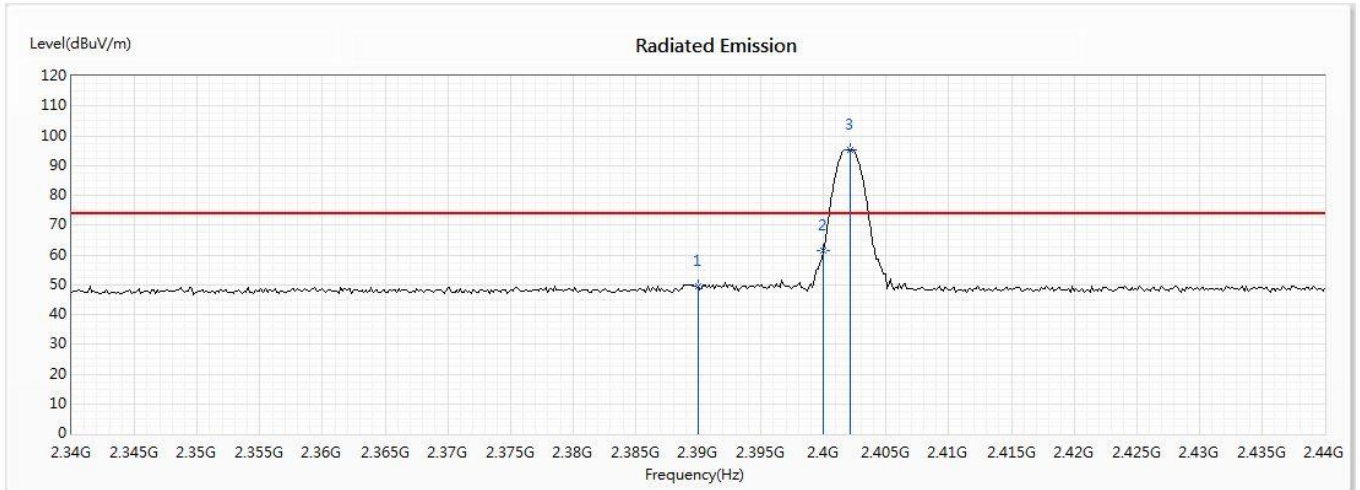

No	Frequency (MHz)	Emission Level (dBuV/m)	Limit (dBuV/m)	Margin (dB)	Reading Level (dBuV)	Correct Factor (dB/m)	Detector Type
1	2390	49.53	74.00	-24.47	36.64	12.89	PK
2	2400	61.41	--	--	48.45	12.96	PK
! 3	2402.174	95.43	--	--	82.46	12.97	PK

Note:

1. All readings above 1GHz are performed with peak and/or average measurements as necessary.
2. Peak measurements: RBW = 1MHz, VBW = 3 MHz, Sweep: Auto.
3. Measurement Level = Reading Level + Correct Factor.
4. The average measurement was not performed when the peak measured data under the limit of average detection.

Channel No.	Frequency (MHz)	Peak Measurement (dBuV/m)	Duty Cycle Factor (dB)	Average Measurement (dBuV/m)	Average Limit (dBuV/m)	Result
00 (Average)	2390	49.53	-30.755	18.775	54.000	Pass
00 (Average)	2400	61.41	-30.755	30.655	--	Pass
00 (Average)	2402.174	95.43	-30.755	64.675	--	Pass

Note:

1. Average Measurement=Peak Measurement + Duty Cycle Factor
2. The Duty Cycle is refer to section 5.

Product : WiFi SOM Module  
 Test Item : Band Edge  
 Test Site : No.3 OATS  
 Test date : 2019/12/27  
 Test Mode : Mode 1: Bluetooth 1Mbps (2480MHz)

Horizontal

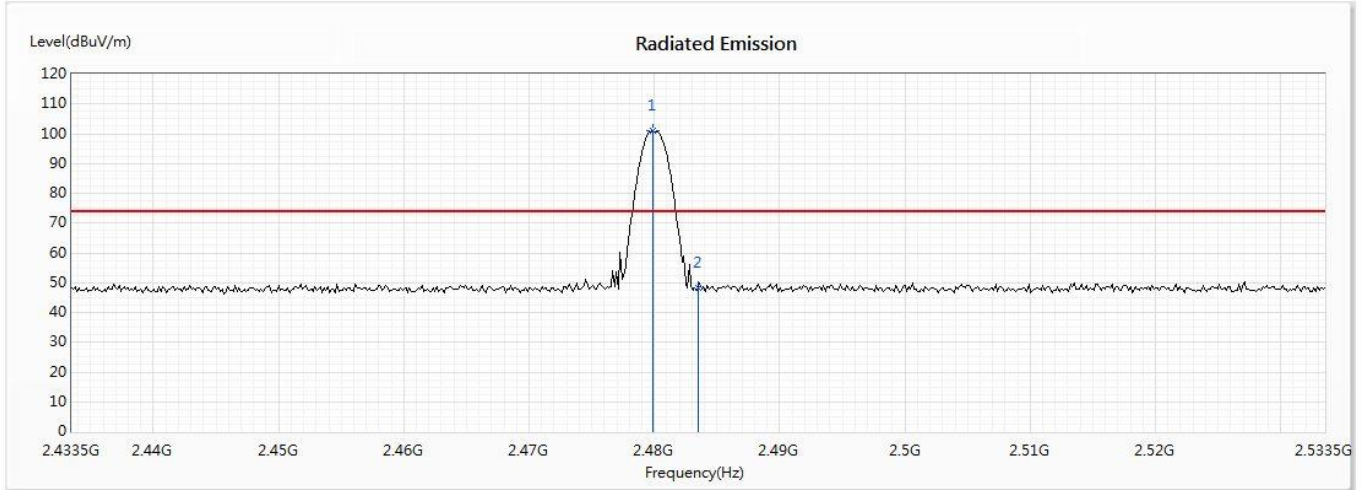

No	Frequency (MHz)	Emission Level (dBuV/m)	Limit (dBuV/m)	Margin (dB)	Reading Level (dBuV)	Correct Factor (dB/m)	Detector Type
! 1	2479.877	100.83	--	--	87.46	13.37	PK
2	2483.5	48.06	74.00	-25.94	34.68	13.38	PK

Note:

1. All readings above 1GHz are performed with peak and/or average measurements as necessary.
2. Peak measurements: RBW = 1MHz, VBW = 3 MHz, Sweep: Auto.
3. Measurement Level = Reading Level + Correct Factor.
4. The average measurement was not performed when the peak measured data under the limit of average detection.

Channel No.	Frequency (MHz)	Peak Measurement (dBμV/m)	Duty Cycle Factor (dB)	Average Measurement (dBμV/m)	Average Limit (dBμV/m)	Result
78 (Average)	2479.877	100.83	-30.755	100.976	--	Pass
78 (Average)	2483.5	48.06	-30.755	51.714	54.000	Pass

Note:

1. Average Measurement=Peak Measurement + Duty Cycle Factor
2. The Duty Cycle is refer to section 5.

Product : WiFi SOM Module  
 Test Item : Band Edge  
 Test Site : No.3 OATS  
 Test date : 2019/12/27  
 Test Mode : Mode 1: Bluetooth 1Mbps (2480MHz)

VERTICAL

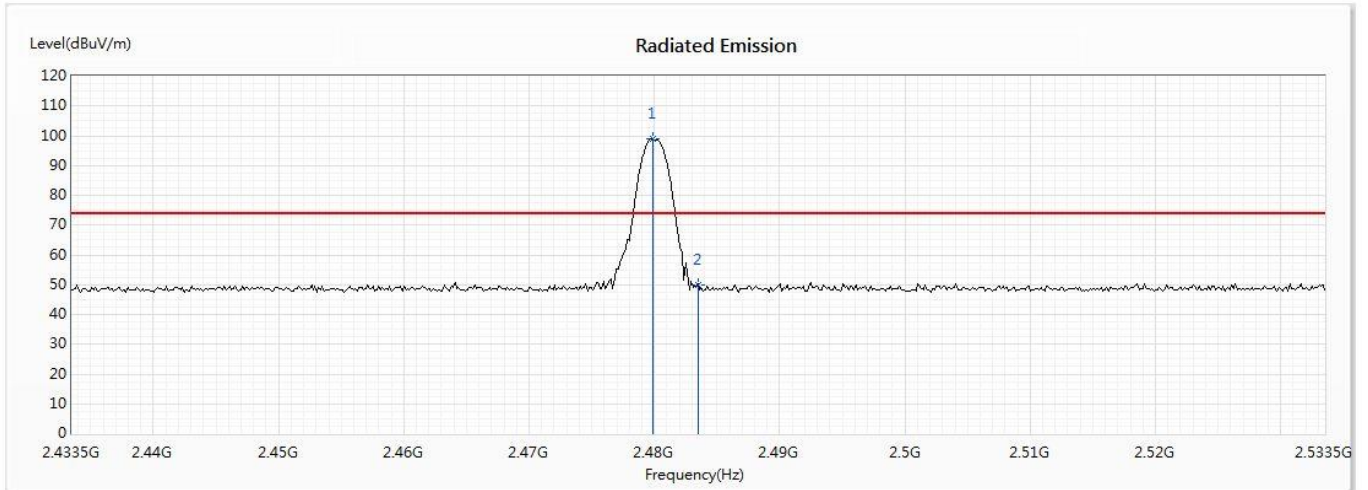

No	Frequency (MHz)	Emission Level (dBuV/m)	Limit (dBuV/m)	Margin (dB)	Reading Level (dBuV)	Correct Factor (dB/m)	Detector Type
! 1	2479.877	98.87	--	--	85.50	13.37	PK
2	2483.5	50.10	74.00	-23.90	36.72	13.38	PK

Note:

1. All readings above 1GHz are performed with peak and/or average measurements as necessary.
2. Peak measurements: RBW = 1MHz, VBW = 3 MHz, Sweep: Auto.
3. Measurement Level = Reading Level + Correct Factor.
4. The average measurement was not performed when the peak measured data under the limit of average detection.

Channel No.	Frequency (MHz)	Peak Measurement (dBuV/m)	Duty Cycle Factor (dB)	Average Measurement (dBuV/m)	Average Limit (dBuV/m)	Result
78 (Average)	2479.877	98.87	-30.755	100.976	--	Pass
78 (Average)	2483.5	50.1	-30.755	51.714	54.000	Pass

Note:

1. Average Measurement=Peak Measurement + Duty Cycle Factor
2. The Duty Cycle is refer to section 5.

Product : WiFi SOM Module  
 Test Item : Band Edge  
 Test Site : No.3 OATS  
 Test date : 2019/12/27  
 Test Mode : Mode 2: Bluetooth 2Mbps (2402MHz)

Horizontal

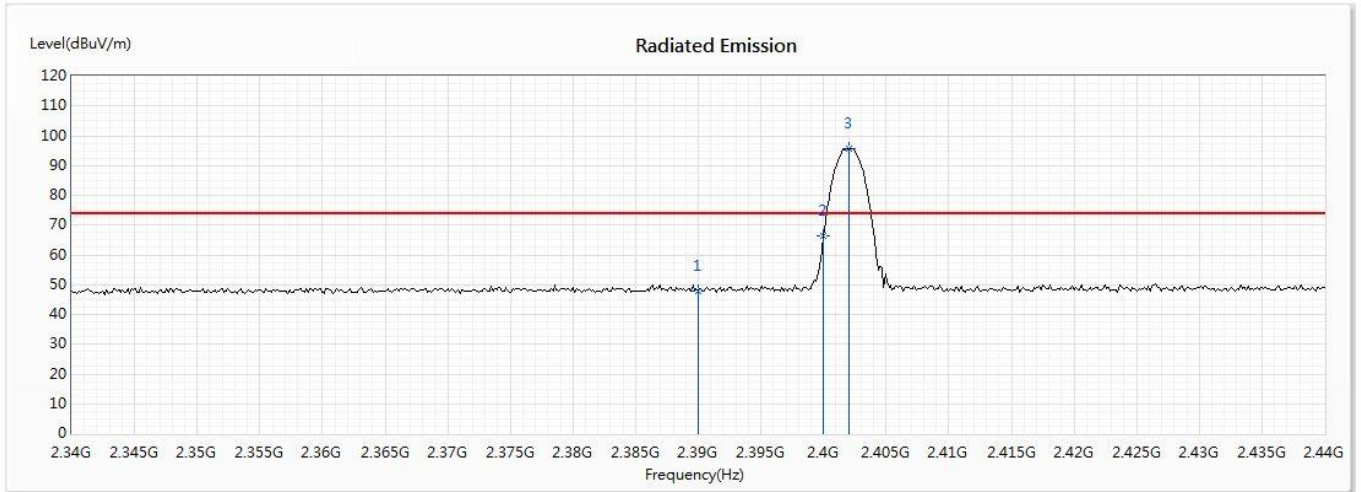

No	Frequency (MHz)	Emission Level (dBuV/m)	Limit (dBuV/m)	Margin (dB)	Reading Level (dBuV)	Correct Factor (dB/m)	Detector Type
1	2390	47.99	74.00	-26.01	35.10	12.89	PK
2	2400	66.33	--	--	53.37	12.96	PK
! 3	2402.029	95.68	--	--	82.71	12.97	PK

Note:

1. All readings above 1GHz are performed with peak and/or average measurements as necessary.
2. Peak measurements: RBW = 1MHz, VBW = 3 MHz, Sweep: Auto.
3. Measurement Level = Reading Level + Correct Factor.
4. The average measurement was not performed when the peak measured data under the limit of average detection.

Channel No.	Frequency (MHz)	Peak Measurement (dBμV/m)	Duty Cycle Factor (dB)	Average Measurement (dBμV/m)	Average Limit (dBμV/m)	Result
00 (Average)	2390	47.99	-30.755	17.235	54.000	Pass
00 (Average)	2400	66.33	-30.755	35.575	--	Pass
00 (Average)	2402.029	95.68	-30.755	64.925	--	Pass

Note:

1. Average Measurement=Peak Measurement + Duty Cycle Factor
2. The Duty Cycle is refer to section 5.



Product : WiFi SOM Module  
 Test Item : Band Edge  
 Test Site : No.3 OATS  
 Test date : 2019/12/27  
 Test Mode : Mode 2: Bluetooth 2Mbps (2402MHz)

VERTICAL

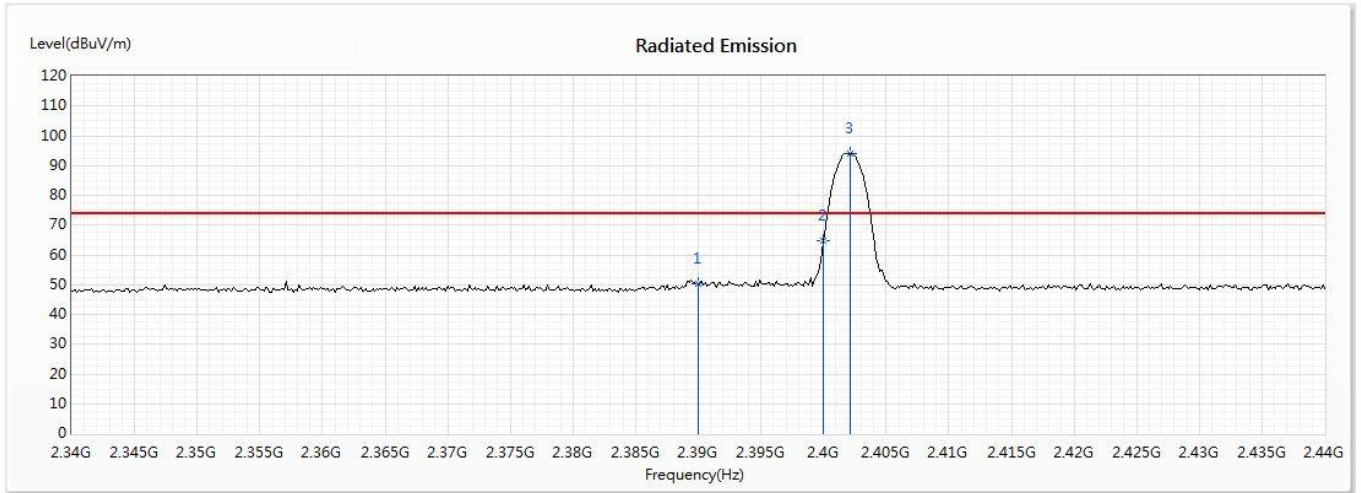

No	Frequency (MHz)	Emission Level (dBuV/m)	Limit (dBuV/m)	Margin (dB)	Reading Level (dBuV)	Correct Factor (dB/m)	Detector Type
1	2390	50.40	74.00	-23.60	37.51	12.89	PK
2	2400	64.57	--	--	51.61	12.96	PK
! 3	2402.174	94.13	--	--	81.16	12.97	PK

Note:

1. All readings above 1GHz are performed with peak and/or average measurements as necessary.
2. Peak measurements: RBW = 1MHz, VBW = 3 MHz, Sweep: Auto.
3. Measurement Level = Reading Level + Correct Factor.
4. The average measurement was not performed when the peak measured data under the limit of average detection.

Channel No.	Frequency (MHz)	Peak Measurement (dBμV/m)	Duty Cycle Factor (dB)	Average Measurement (dBμV/m)	Average Limit (dBμV/m)	Result
00 (Average)	2390	50.4	-30.755	19.645	54.000	Pass
00 (Average)	2400	64.57	-30.755	33.815	--	Pass
00 (Average)	2402.174	94.13	-30.755	63.375	--	Pass

Note:

1. Average Measurement=Peak Measurement + Duty Cycle Factor
2. The Duty Cycle is refer to section 5.



Product : WiFi SOM Module  
 Test Item : Band Edge  
 Test Site : No.3 OATS  
 Test date : 2019/12/27  
 Test Mode : Mode 2: Bluetooth 2Mbps (2480MHz)

Horizontal

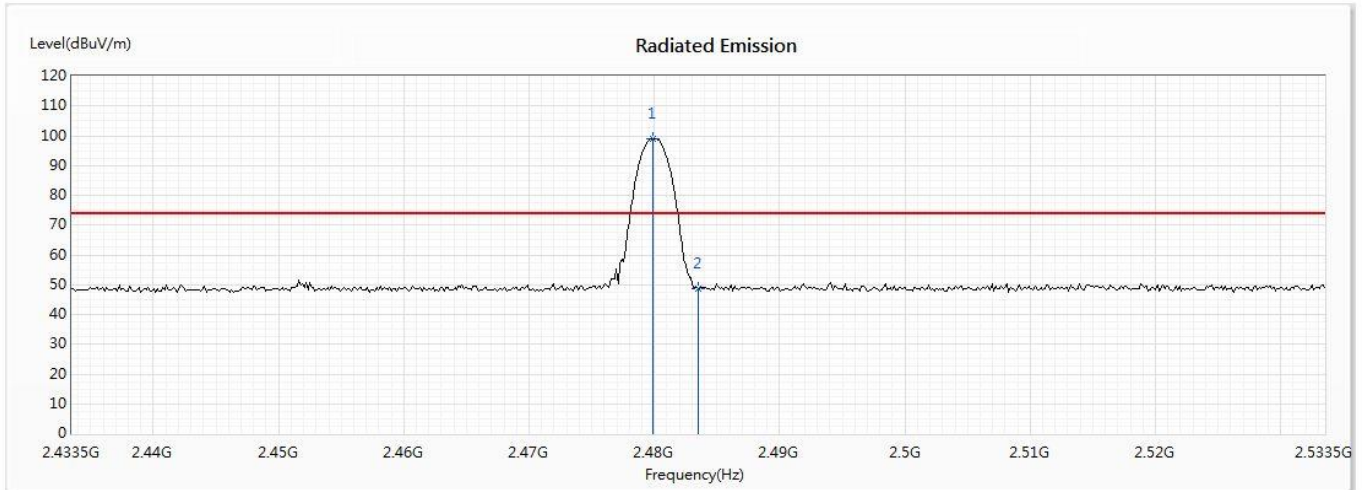

No	Frequency (MHz)	Emission Level (dBuV/m)	Limit (dBuV/m)	Margin (dB)	Reading Level (dBuV)	Correct Factor (dB/m)	Detector Type
! 1	2479.877	99.00	--	--	85.63	13.37	PK
2	2483.5	48.53	74.00	-25.47	35.15	13.38	PK

Note:

1. All readings above 1GHz are performed with peak and/or average measurements as necessary.
2. Peak measurements: RBW = 1MHz, VBW = 3 MHz, Sweep: Auto.
3. Measurement Level = Reading Level + Correct Factor.
4. The average measurement was not performed when the peak measured data under the limit of average detection.

Channel No.	Frequency (MHz)	Peak Measurement (dBμV/m)	Duty Cycle Factor (dB)	Average Measurement (dBμV/m)	Average Limit (dBμV/m)	Result
78 (Average)	2479.877	99	-30.755	100.976	--	Pass
78 (Average)	2483.5	48.53	-30.755	51.714	54.000	Pass

Note:

1. Average Measurement=Peak Measurement + Duty Cycle Factor
2. The Duty Cycle is refer to section 5.

Product : WiFi SOM Module  
 Test Item : Band Edge  
 Test Site : No.3 OATS  
 Test date : 2019/12/27  
 Test Mode : Mode 2: Bluetooth 2Mbps (2480MHz)

VERTICAL

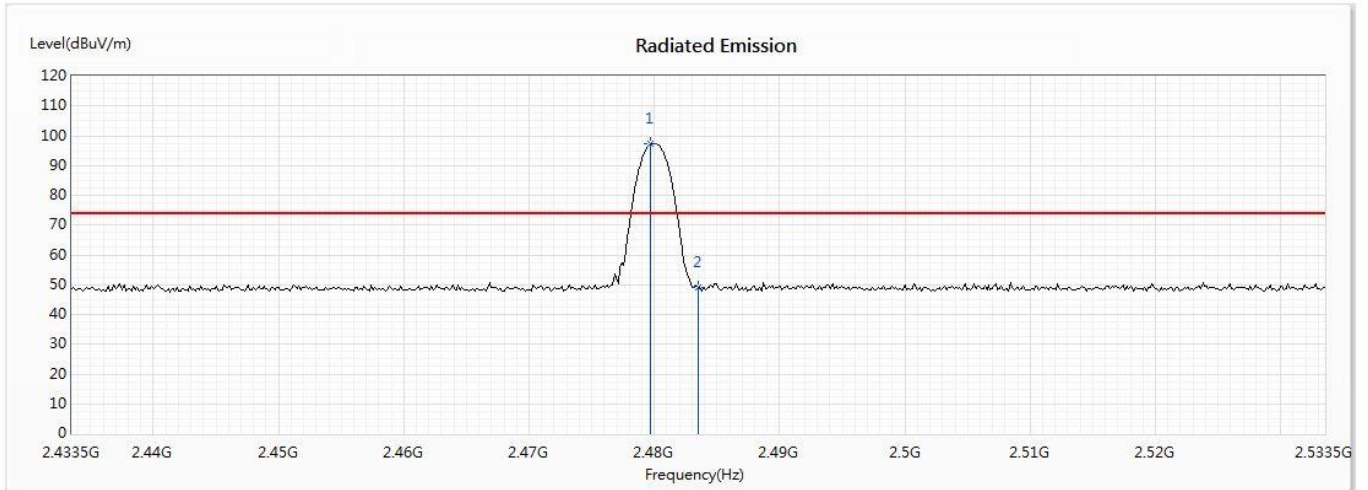

No	Frequency (MHz)	Emission Level (dBuV/m)	Limit (dBuV/m)	Margin (dB)	Reading Level (dBuV)	Correct Factor (dB/m)	Detector Type
! 1	2479.732	97.40	--	--	84.03	13.37	PK
2	2483.5	48.97	74.00	-25.03	35.59	13.38	PK

Note:

1. All readings above 1GHz are performed with peak and/or average measurements as necessary.
2. Peak measurements: RBW = 1MHz, VBW = 3 MHz, Sweep: Auto.
3. Measurement Level = Reading Level + Correct Factor.
4. The average measurement was not performed when the peak measured data under the limit of average detection.

Channel No.	Frequency (MHz)	Peak Measurement (dBμV/m)	Duty Cycle Factor (dB)	Average Measurement (dBμV/m)	Average Limit (dBμV/m)	Result
78 (Average)	2479.732	97.4	-30.755	100.976	--	Pass
78 (Average)	2483.5	48.97	-30.755	51.714	54.000	Pass

Note:

1. Average Measurement=Peak Measurement + Duty Cycle Factor
2. The Duty Cycle is refer to section 5.

Product : WiFi SOM Module  
 Test Item : Band Edge  
 Test Site : No.3 OATS  
 Test date : 2019/12/27  
 Test Mode : Mode 3: Bluetooth 3Mbps (2402MHz)

Horizontal

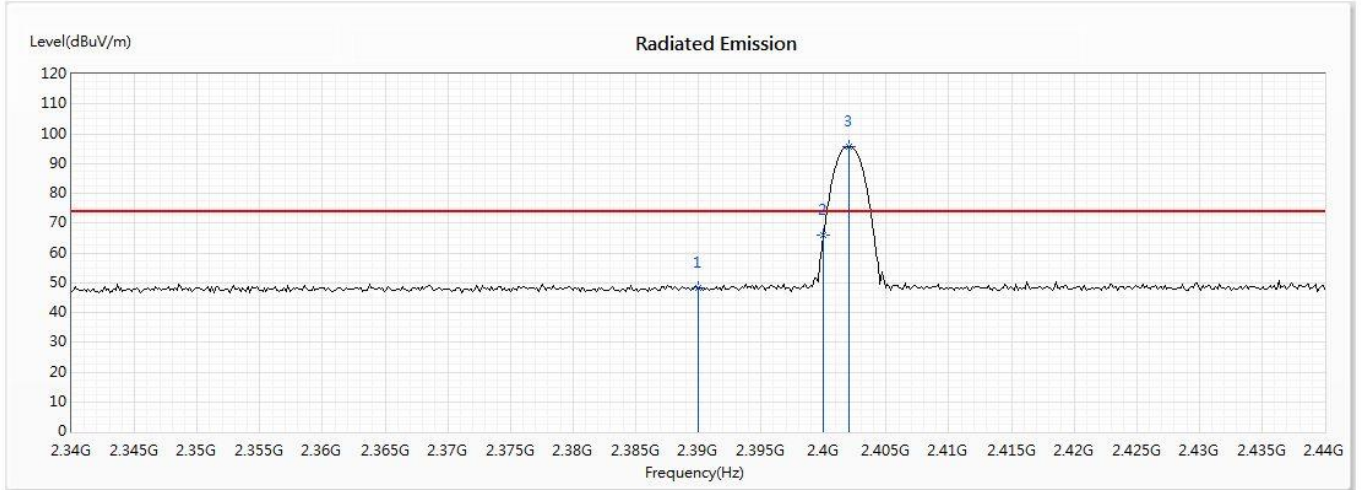

No	Frequency (MHz)	Emission Level (dBuV/m)	Limit (dBuV/m)	Margin (dB)	Reading Level (dBuV)	Correct Factor (dB/m)	Detector Type
1	2390	48.15	74.00	-25.85	35.26	12.89	PK
2	2400	65.89	--	--	52.93	12.96	PK
! 3	2402.029	95.74	--	--	82.77	12.97	PK

Note:

1. All readings above 1GHz are performed with peak and/or average measurements as necessary.
2. Peak measurements: RBW = 1MHz, VBW = 3 MHz, Sweep: Auto.
3. Measurement Level = Reading Level + Correct Factor.
4. The average measurement was not performed when the peak measured data under the limit of average detection.

Channel No.	Frequency (MHz)	Peak Measurement (dBμV/m)	Duty Cycle Factor (dB)	Average Measurement (dBμV/m)	Average Limit (dBμV/m)	Result
00 (Average)	2390	48.15	-30.755	17.395	54.000	Pass
00 (Average)	2400	65.89	-30.755	35.135	--	Pass
00 (Average)	2402.029	95.74	-30.755	64.985	--	Pass

Note:

1. Average Measurement=Peak Measurement + Duty Cycle Factor
2. The Duty Cycle is refer to section 5.

Product : WiFi SOM Module  
 Test Item : Band Edge  
 Test Site : No.3 OATS  
 Test date : 2019/12/27  
 Test Mode : Mode 3: Bluetooth 3Mbps (2402MHz)

VERTICAL

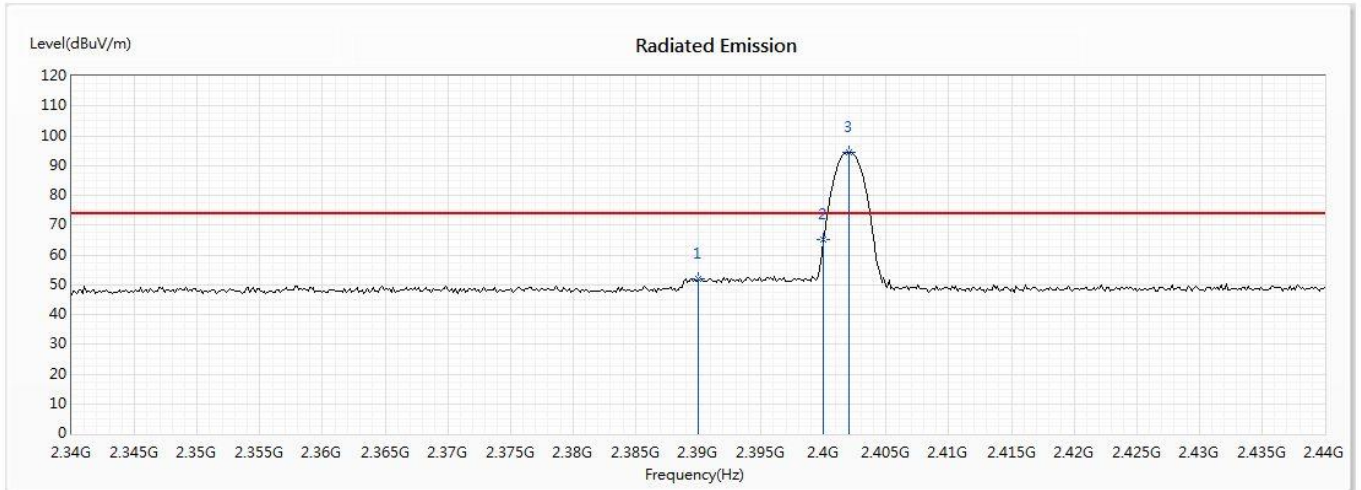

No	Frequency (MHz)	Emission Level (dBuV/m)	Limit (dBuV/m)	Margin (dB)	Reading Level (dBuV)	Correct Factor (dB/m)	Detector Type
1	2390	52.13	74.00	-21.87	39.24	12.89	PK
2	2400	65.08	--	--	52.12	12.96	PK
! 3	2402.029	94.36	--	--	81.39	12.97	PK

Note:

1. All readings above 1GHz are performed with peak and/or average measurements as necessary.
2. Peak measurements: RBW = 1MHz, VBW = 3 MHz, Sweep: Auto.
3. Measurement Level = Reading Level + Correct Factor.
4. The average measurement was not performed when the peak measured data under the limit of average detection.

Channel No.	Frequency (MHz)	Peak Measurement (dBμV/m)	Duty Cycle Factor (dB)	Average Measurement (dBμV/m)	Average Limit (dBμV/m)	Result
00 (Average)	2390	52.13	-30.755	21.375	54.000	Pass
00 (Average)	2400	65.08	-30.755	34.325	--	Pass
00 (Average)	2402.029	94.36	-30.755	63.605	--	Pass

Note:

1. Average Measurement=Peak Measurement + Duty Cycle Factor
2. The Duty Cycle is refer to section 5.

Product : WiFi SOM Module  
 Test Item : Band Edge  
 Test Site : No.3 OATS  
 Test date : 2019/12/27  
 Test Mode : Mode 3: Bluetooth 3Mbps (2480MHz)

Horizontal

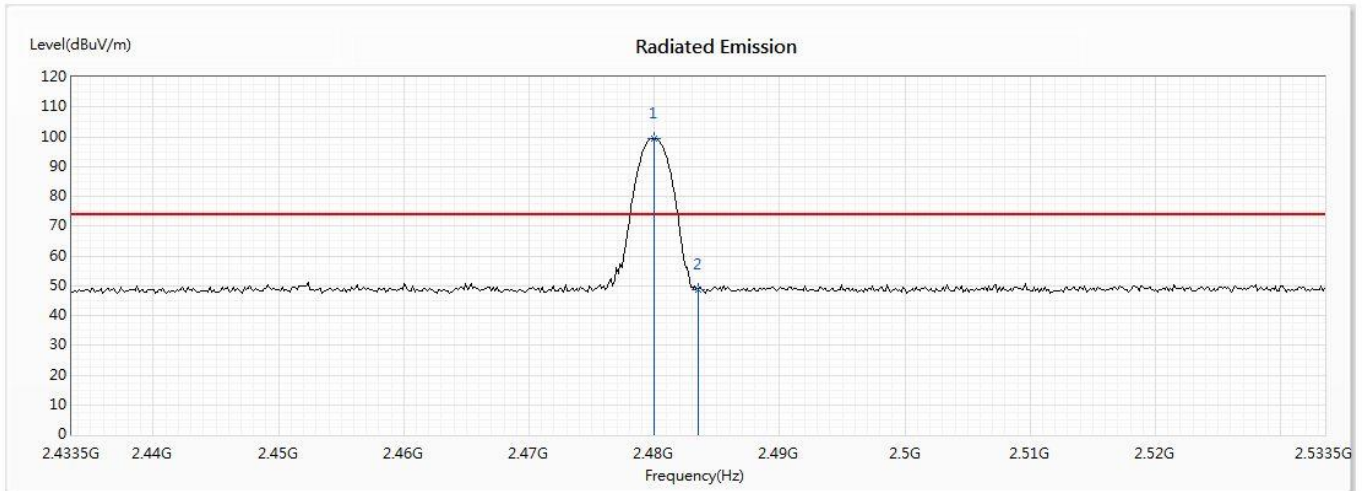

No	Frequency (MHz)	Emission Level (dBuV/m)	Limit (dBuV/m)	Margin (dB)	Reading Level (dBuV)	Correct Factor (dB/m)	Detector Type
! 1	2480.022	99.39	--	--	86.02	13.37	PK
2	2483.5	48.54	74.00	-25.46	35.16	13.38	PK

Note:

1. All readings above 1GHz are performed with peak and/or average measurements as necessary.
2. Peak measurements: RBW = 1MHz, VBW = 3 MHz, Sweep: Auto.
3. Measurement Level = Reading Level + Correct Factor.
4. The average measurement was not performed when the peak measured data under the limit of average detection.

Channel No.	Frequency (MHz)	Peak Measurement (dBμV/m)	Duty Cycle Factor (dB)	Average Measurement (dBμV/m)	Average Limit (dBμV/m)	Result
78 (Average)	2480.022	99.39	-30.755	100.976	--	Pass
78 (Average)	2483.5	48.54	-30.755	51.714	54.000	Pass

Note:

1. Average Measurement=Peak Measurement + Duty Cycle Factor
2. The Duty Cycle is refer to section 5.



Product : WiFi SOM Module  
 Test Item : Band Edge  
 Test Site : No.3 OATS  
 Test date : 2019/12/27  
 Test Mode : Mode 3: Bluetooth 3Mbps (2480MHz)

VERTICAL

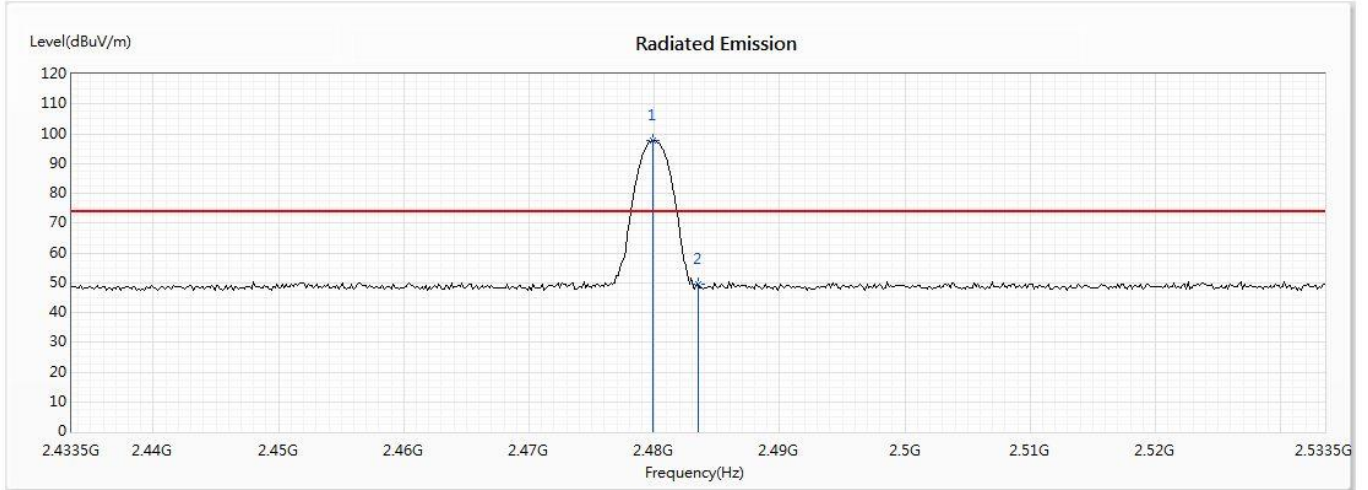

No	Frequency (MHz)	Emission Level (dBuV/m)	Limit (dBuV/m)	Margin (dB)	Reading Level (dBuV)	Correct Factor (dB/m)	Detector Type
! 1	2479.877	97.66	--	--	84.29	13.37	PK
2	2483.5	49.49	74.00	-24.51	36.11	13.38	PK

Note:

1. All readings above 1GHz are performed with peak and/or average measurements as necessary.
2. Peak measurements: RBW = 1MHz, VBW = 3 MHz, Sweep: Auto.
3. Measurement Level = Reading Level + Correct Factor.
4. The average measurement was not performed when the peak measured data under the limit of average detection.

Channel No.	Frequency (MHz)	Peak Measurement (dBμV/m)	Duty Cycle Factor (dB)	Average Measurement (dBμV/m)	Average Limit (dBμV/m)	Result
78 (Average)	2479.877	97.66	-30.755	100.976	--	Pass
78 (Average)	2483.5	49.49	-30.755	51.714	54.000	Pass

Note:

1. Average Measurement=Peak Measurement + Duty Cycle Factor
2. The Duty Cycle is refer to section 5.

## 5. Duty Cycle

### 5.1. Test Setup

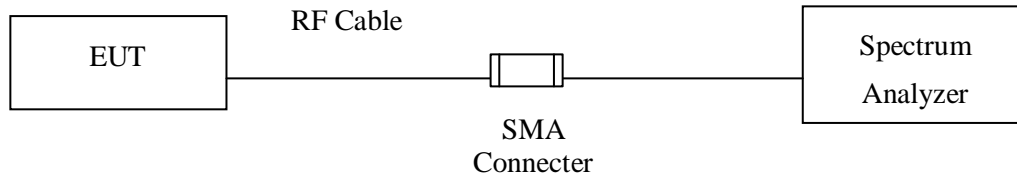

### 5.2. Uncertainty

± 25msec

### 5.3. Test Result of Duty Cycle

Product : WiFi SOM Module  
 Test Item : Duty Cycle  
 Test Site : No.3 OATS  
 Test Mode : Mode 1: Bluetooth 1Mbps

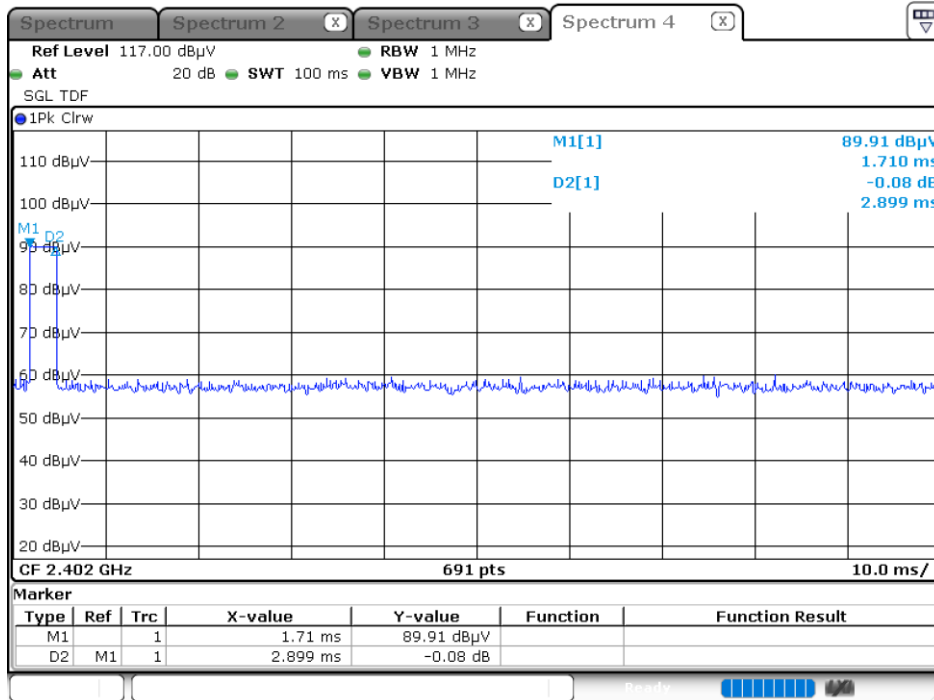

Date: 27.DEC.2019 01:52:50

Time on of 100ms= 2.899ms

Duty Cycle=2.899ms / 100ms= 0.02899

Duty Cycle correction factor= 20 LOG 0.02899= -30.755 dB

<b>Duty Cycle correction factor</b>	<b>-30.755</b>	<b>dB</b>
-------------------------------------	----------------	-----------



Product : WiFi SOM Module  
 Test Item : Duty Cycle  
 Test Site : No.3 OATS  
 Test Mode : Mode 2: Bluetooth 2Mbps

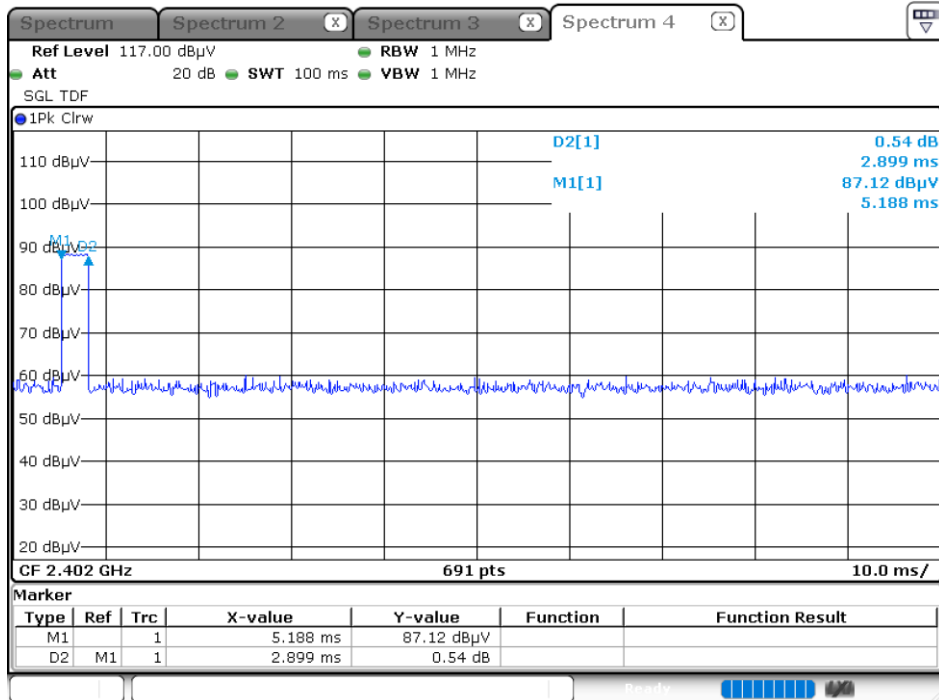

Date: 27.DEC.2019 01:53:27

Time on of 100ms= 2.899ms

Duty Cycle=2.899ms / 100ms= 0.02899

Duty Cycle correction factor= 20 LOG 0.02899= -30.755 dB

<b>Duty Cycle correction factor</b>	<b>-30.755</b>	<b>dB</b>
-------------------------------------	----------------	-----------

Product : WiFi SOM Module  
 Test Item : Duty Cycle  
 Test Site : No.3 OATS  
 Test Mode : Mode 3: Bluetooth 3Mbps

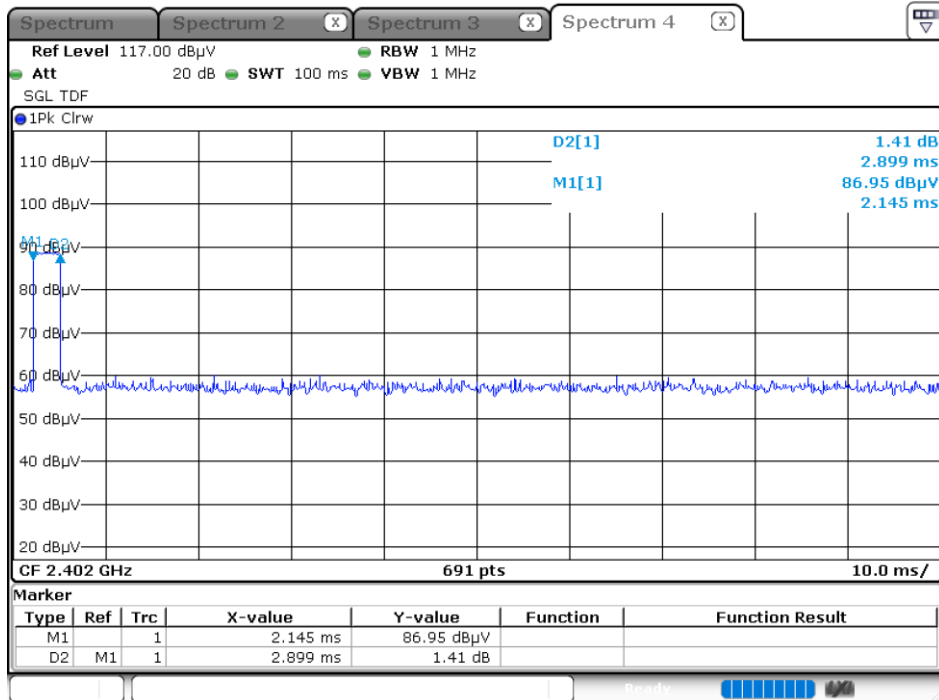

Date: 27.DEC.2019 01:54:13

Time on of 100ms= 2.899ms

Duty Cycle= $2.899\text{ms} / 100\text{ms} = 0.02899$

Duty Cycle correction factor= $20 \text{ LOG } 0.02899 = -30.755 \text{ dB}$

<b>Duty Cycle correction factor</b>	<b>-30.755</b>	<b>dB</b>
-------------------------------------	----------------	-----------

## **6. EMI Reduction Method During Compliance Testing**

No modification was made during testing.