

## FCC Test Report (WLAN)

**Report No.:** RF161031E01

**FCC ID:** 2ABTEIPSTB1200

**Test Model:** IPSTB1200

**Received Date:** Oct. 31, 2016

**Test Date:** Nov. 16 to 22, 2016

**Issued Date:** Nov. 24, 2016

**Applicant:** Verizon Online LLC

**Address:** 1300 I Street NW, Room 400W, Washington, District of Columbia, 20005, United State

**Issued By:** Bureau Veritas Consumer Products Services (H.K.) Ltd., Taoyuan Branch Hsin Chu Laboratory

**Lab Address:** E-2, No.1, Li Hsin 1st Road, Hsinchu Science Park, Hsinchu City 300, Taiwan R.O.C.

**Test Location (1):** E-2, No.1, Li Hsin 1st Road, Hsinchu Science Park, Hsinchu City 300, Taiwan R.O.C.

**Test Location (2):** No. 49, Ln. 206, Wende Rd., Shangshan Tsuen, Chiung Lin Hsiang, Hsin Chu Hsien 307, Taiwan R.O.C.



This report is for your exclusive use. Any copying or replication of this report to or for any other person or entity, or use of our name or trademark, is permitted only with our prior written permission. This report sets forth our findings solely with respect to the test samples identified herein. The results set forth in this report are not indicative or representative of the quality or characteristics of the lot from which a test sample was taken or any similar or identical product unless specifically and expressly noted. Our report includes all of the tests requested by you and the results thereof based upon the information that you provided to us. You have 60 days from date of issuance of this report to notify us of any material error or omission caused by our negligence, provided, however, that such notice shall be in writing and shall specifically address the issue you wish to raise. A failure to raise such issue within the prescribed time shall constitute your unqualified acceptance of the completeness of this report, the tests conducted and the correctness of the report contents. Unless specific mention, the uncertainty of measurement has been explicitly taken into account to declare the compliance or non-compliance to the specification. The report must not be used by the client to claim product certification, approval, or endorsement by TAF or any government agencies.

## Table of Contents

<b>Release Control Record</b> .....	<b>4</b>
<b>1 Certificate of Conformity</b> .....	<b>5</b>
<b>2 Summary of Test Results</b> .....	<b>6</b>
2.1 Measurement Uncertainty .....	6
2.2 Modification Record .....	6
<b>3 General Information</b> .....	<b>7</b>
3.1 General Description of EUT .....	7
3.2 Description of Test Modes .....	10
3.2.1 Test Mode Applicability and Tested Channel Detail .....	12
3.3 Duty Cycle of Test Signal .....	15
3.4 Description of Support Units .....	16
3.4.1 Configuration of System under Test .....	17
3.5 General Description of Applied Standard .....	18
<b>4 Test Types and Results</b> .....	<b>19</b>
4.1 Radiated Emission and Bandedge Measurement .....	19
4.1.1 Limits of Radiated Emission and Bandedge Measurement .....	19
4.1.2 Test Instruments .....	20
4.1.3 Test Procedure .....	22
4.1.4 Deviation from Test Standard .....	22
4.1.5 Test Setup .....	23
4.1.6 EUT Operating Condition .....	24
4.1.7 Test Results .....	25
4.2 Conducted Emission Measurement .....	68
4.2.1 Limits of Conducted Emission Measurement .....	68
4.2.2 Test Instruments .....	68
4.2.3 Test Procedure .....	69
4.2.4 Deviation from Test Standard .....	69
4.2.5 Test Setup .....	69
4.2.6 EUT Operating Condition .....	69
4.2.7 Test Results .....	70
4.3 Transmit Power Measurement .....	72
4.3.1 Limits of Transmit Power Measurement .....	72
4.3.2 Test Setup .....	73
4.3.3 Test Instruments .....	73
4.3.4 Test Procedure .....	74
4.3.5 Deviation from Test Standard .....	74
4.3.6 EUT Operating Condition .....	74
4.3.7 Test Result .....	75
4.4 Occupied Bandwidth Measurement .....	84
4.4.1 Test Setup .....	84
4.4.2 Test Instruments .....	84
4.4.3 Test Procedure .....	84
4.4.4 Test Results .....	85
4.5 Peak Power Spectral Density Measurement .....	90
4.5.1 Limits of Peak Power Spectral Density Measurement .....	90
4.5.2 Test Setup .....	90
4.5.3 Test Instruments .....	90
4.5.4 Test Procedure .....	91
4.5.5 Deviation from Test Standard .....	91
4.5.6 EUT Operating Condition .....	91
4.5.7 Test Results .....	92
4.6 Frequency Stability Measurement .....	99
4.6.1 Limits of Frequency Stability Measurement .....	99

4.6.2	Test Setup.....	99
4.6.3	Test Instruments .....	99
4.6.4	Test Procedure .....	99
4.6.5	Deviation from Test Standard .....	99
4.6.6	EUT Operating Condition .....	99
4.6.7	Test Results .....	100
4.7	6dB Bandwidth Measurement .....	101
4.7.1	Limits of 6dB Bandwidth Measurement.....	101
4.7.2	Test Setup.....	101
4.7.3	Test Instruments .....	101
4.7.4	Test Procedure .....	101
4.7.5	Deviation from Test Standard .....	101
4.7.6	EUT Operating Condition .....	101
4.7.7	Test Results .....	102
<b>5</b>	<b>Pictures of Test Arrangements.....</b>	<b>104</b>
	<b>Annex A- Radiated Out of Band Emission (OOBE) Measurement (For U-NII-3 band) .....</b>	<b>105</b>
	<b>Appendix – Information on the Testing Laboratories .....</b>	<b>108</b>

### Release Control Record

Issue No.	Description	Date Issued
RF161031E01	Original release.	Nov. 24, 2016

## 1 Certificate of Conformity

**Product:** IPSTB1200 tv box

**Brand:** Verizon

**Test Model:** IPSTB1200

**Sample Status:** ENGINEERING SAMPLE

**Applicant:** Verizon Online LLC

**Test Date:** Nov. 16 to 22, 2016

**Standard:** 47 CFR FCC Part 15, Subpart E (Section 15.407)  
ANSI C63.10: 2013

The above equipment has been tested by **Bureau Veritas Consumer Products Services (H.K.) Ltd., Taoyuan Branch**, and found compliance with the requirement of the above standards. The test record, data evaluation & Equipment Under Test (EUT) configurations represented herein are true and accurate accounts of the measurements of the sample's EMC characteristics under the conditions specified in this report.

**Prepared by :**  , **Date:** Nov. 24, 2016  
Claire Kuan / Specialist

**Approved by :**  , **Date:** Nov. 24, 2016  
May Chen / Manager

## 2 Summary of Test Results

47 CFR FCC Part 15, Subpart E (Section 15.407)			
FCC Clause	Test Item	Result	Remarks
15.407(b)(6)	AC Power Conducted Emissions	Pass	Meet the requirement of limit. Minimum passing margin is -15.47dB at 0.38828MHz.
15.407(b)(1/2/3/4(i/ii)/6)	Radiated Emissions & Band Edge Measurement*	Pass	Meet the requirement of limit. Minimum passing margin is -0.1dB at 5350.00MHz & 5725.00MHz.
15.407(a)(1/2/3)	Max Average Transmit Power	Pass	Meet the requirement of limit.
---	Occupied Bandwidth Measurement	-	Reference only.
15.407(a)(1/2/3)	Peak Power Spectral Density	Pass	Meet the requirement of limit.
15.407(e)	6dB bandwidth	Pass	Meet the requirement of limit. (U-NII-3 Band only)
15.407(g)	Frequency Stability	Pass	Meet the requirement of limit.
15.203	Antenna Requirement	Pass	Antenna connector is i-pex(MHF) not a standard connector.

\*For U-NII-3 band compliance with rule part 15.407(b)(4)(i), the OOB test plots were recorded in Annex A.

### 2.1 Measurement Uncertainty

Where relevant, the following measurement uncertainty levels have been estimated for tests performed on the EUT as specified in CISPR 16-4-2:

Measurement	Frequency	Expanded Uncertainty (k=2) (±)
Conducted Emissions at mains ports	150kHz ~ 30MHz	1.83 dB
Radiated Emissions up to 1 GHz	30MHz ~ 1GHz	5.36 dB
Radiated Emissions above 1 GHz	1GHz ~ 6GHz	3.47 dB
	6GHz ~ 18GHz	3.75 dB
	18GHz ~ 40GHz	3.30 dB

### 2.2 Modification Record

There were no modifications required for compliance.

### 3 General Information

#### 3.1 General Description of EUT

Product	IPSTB1200 tv box
Brand	Verizon
Test Model	IPSTB1200
Status of EUT	ENGINEERING SAMPLE
Power Supply Rating	DC 12V from power adapter
Modulation Type	64QAM, 16QAM, QPSK, BPSK for OFDM 256QAM for OFDM in 11ac mode
Modulation Technology	DSSS,OFDM
Transfer Rate	802.11a: up to 54Mbps 802.11n: up to 600Mbps 802.11ac: up to 866.7Mbps
Operating Frequency	5.18~5.24GHz, 5.26~5.32GHz, 5.50~5.72GHz, 5.745~5.825GHz
Number of Channel	802.11a, 802.11n (HT20), 802.11ac (VHT20): 25 802.11n (HT40), 802.11ac (VHT40): 12 802.11ac (VHT80): 6
Output Power	<b>CDD Mode :</b> 5180-5240MHz : 248.906mW 5260-5320MHz : 246.622mW 5500-5700MHz : 242.212mW 5745-5825MHz : 260.097mW <b>beamforming Mode :</b> 5180-5240MHz : 246.339mW 5260-5320MHz : 247.19mW 5500-5700MHz : 248.022mW 5745-5825MHz : 267.205mW
Antenna Type	Refer to Note
Antenna Connector	Refer to Note
Accessory Device	Adapter x 1 Remote Control (Brand: Verizon, Model: IPRC1000) x 1
Data Cable Supplied	HDMI cable (Shielded, 1.5m) x 1

Note:

1. Simultaneously transmission condition.

Condition	Technology	
1	WLAN (5GHz)	Bluetooth

**Note:** The emission of the simultaneous operation has been evaluated and no non-compliance was found.

2. The EUT must be supplied with a power adapter as following table:

Brand	Model No.	Spec.
Delta	IPSTB1000-PS	Input: 100-120Vac, 60Hz, 0.6A Output: 12Vdc, 2.0A DC output cable (Unshielded, 1.2m)

3. The antennas provided to the EUT, please refer to the following table:

5GHz						
Antenna No	Brand	Antenna Net Gain(dBi)	Frequency range (GHz~GHz)	Antenna Type	Connector type	Cable Length (mm)
Antenna 1 (TX/RX)	WNC	4.1	5.15~5.25	Dipole	i-pex(MHF)	100
		4.84	5.25~5.35			
		5.4	5.47~5.725			
		5	5.725~5.85			
Antenna 2 (TX/RX)	WNC	3.39	5.15~5.25	Dipole	i-pex(MHF)	65
		3.41	5.25~5.35			
		3.75	5.47~5.725			
		3.92	5.725~5.85			
Antenna 3 (RX)	WNC	2.77	5.15~5.25	Dipole	i-pex(MHF)	116
		3.71	5.25~5.35			
		3.94	5.47~5.725			
		3.94	5.725~5.85			
Antenna 4 (RX)	WNC	6.54	5.15~5.25	PIFA	i-pex(MHF)	155.5
		5.49	5.25~5.35			
		4.8	5.47~5.725			
		4.78	5.725~5.85			
Bluetooth						
Antenna No	Brand	Antenna Net Gain(dBi)	Frequency range (GHz~GHz)	Antenna Type	Connector type	
Antenna 1	WNC	3.62	2.4~2.4835	Monopole	NA	

4. The directional gain as below table:

Frequency	Max Gain (dBi)
5GHz	4.93

Note:

1. Non-TxBF mode & TxBF mode antenna gain refer to KDB 662911 F 2) f) (ii)

$$DirectionalGain = 10 \cdot \log \left[ \frac{\sum_{j=1}^{N_{SS}} \left\{ \sum_{k=1}^{N_{ANT}} g_{j,k} \right\}^2}{N_{ANT}} \right]$$

where

Each antenna is driven by no more than one spatial stream;

$N_{SS}$  = the number of independent spatial streams of data;

$N_{ANT}$  = the total number of antennas

$g_{j,k} = 10^{G_k / 20}$  if the  $k$ th antenna is being fed by spatial stream  $j$ , or zero if it is not;

$G_k$  is the gain in dBi of the  $k$ th antenna.



5. The EUT incorporates a MIMO function:

<b>WLAN 5GHz</b>			
<b>MODULATION MODE</b>	<b>DATA RATE (MCS)</b>	<b>TX &amp; RX CONFIGURATION</b>	
<b>802.11a</b>	6 ~ 54Mbps	2TX	4RX
<b>802.11n (HT20)</b>	MCS 0~7	2TX	4RX
	MCS 8~15	2TX	4RX
	MCS 16~23	2TX	4RX
	MCS 24~31	2TX	4RX
<b>802.11n (HT40)</b>	MCS 0~7	2TX	4RX
	MCS 8~15	2TX	4RX
	MCS 16~23	2TX	4RX
	MCS 24~31	2TX	4RX
<b>802.11ac (VHT20)</b>	MCS0~8 Nss=1	2TX	4RX
	MCS0~8 Nss=2	2TX	4RX
	MCS0~9 Nss=3	2TX	4RX
	MCS0~8 Nss=4	2TX	4RX
<b>802.11ac (VHT40)</b>	MCS0~9 Nss=1	2TX	4RX
	MCS0~9 Nss=2	2TX	4RX
	MCS0~9 Nss=3	2TX	4RX
	MCS0~9 Nss=4	2TX	4RX
<b>802.11ac (VHT80)</b>	MCS0~9 Nss=1	2TX	4RX
	MCS0~9 Nss=2	2TX	4RX
	MCS0~9 Nss=3	2TX	4RX
	MCS0~9 Nss=4	2TX	4RX

Note:

1. All of modulation mode support beamforming function except 802.11a modulation mode.
2. The modulation and bandwidth are similar for 802.11n mode for 20MHz (40MHz) and 802.11ac mode for 20MHz (40MHz), therefore investigated worst case to representative mode in test report. (Final test mode refer section 3.2.1)

6. The above EUT information is declared by manufacturer and for more detailed features description, please refer to the manufacturer's specifications or user's manual.

### 3.2 Description of Test Modes

#### FOR 5180 ~ 5240MHz

4 channels are provided for 802.11a, 802.11n (HT20), 802.11ac (VHT20):

Channel	Frequency	Channel	Frequency
36	5180 MHz	44	5220 MHz
40	5200 MHz	48	5240 MHz

2 channels are provided for 802.11n (HT40), 802.11ac (VHT40):

Channel	Frequency	Channel	Frequency
38	5190 MHz	46	5230 MHz

1 channel is provided for 802.11ac (VHT80):

Channel	Frequency
42	5210MHz

#### FOR 5260 ~ 5320MHz

4 channels are provided for 802.11a, 802.11n (HT20), 802.11ac (VHT20):

Channel	Frequency	Channel	Frequency
52	5260 MHz	60	5300 MHz
56	5280 MHz	64	5320 MHz

2 channels are provided for 802.11n (HT40), 802.11ac (VHT40):

Channel	Frequency	Channel	Frequency
54	5270 MHz	62	5310 MHz

1 channel is provided for 802.11ac (VHT80):

Channel	Frequency
58	5290 MHz

### FOR 5500 ~ 5720MHz

12 channels are provided for 802.11a, 802.11n (HT20), 802.11ac (VHT20):

Channel	Frequency	Channel	Frequency
100	5500 MHz	124	5620 MHz
104	5520 MHz	128	5640 MHz
108	5540 MHz	132	5660 MHz
112	5560 MHz	136	5680 MHz
116	5580 MHz	140	5700 MHz
120	5600 MHz	144	5720 MHz

6 channels are provided for 802.11n (HT40), 802.11ac (VHT40):

Channel	Frequency	Channel	Frequency
102	5510 MHz	126	5630 MHz
110	5550 MHz	134	5670 MHz
118	5590 MHz	142	5710 MHz

3 channels are provided for 802.11ac (VHT80):

Channel	Frequency	Channel	Frequency
106	5530 MHz	138	5690 MHz
122	5610 MHz		

### FOR 5745 ~ 5825MHz:

5 channels are provided for 802.11a, 802.11n (HT20), 802.11ac (VHT20):

Channel	Frequency	Channel	Frequency
149	5745 MHz	161	5805 MHz
153	5765 MHz	165	5825 MHz
157	5785 MHz		

2 channels are provided for 802.11n (HT40), 802.11ac (VHT40):

Channel	Frequency	Channel	Frequency
151	5755 MHz	159	5795 MHz

1 channel is provided for 802.11ac (VHT80):

Channel	Frequency
155	5775 MHz

### 3.2.1 Test Mode Applicability and Tested Channel Detail

EUT Configure Mode	Applicable To				Description
	RE≥1G	RE<1G	PLC	APCM	
	√	√	√	√	

Where **RE≥1G**: Radiated Emission above 1GHz      **RE<1G**: Radiated Emission below 1GHz  
**PLC**: Power Line Conducted Emission      **APCM**: Antenna Port Conducted Measurement

#### **Radiated Emission Test (Above 1GHz):**

- Pre-Scan has been conducted to determine the worst-case mode from all possible combinations between available modulations, data rates and antenna ports (if EUT with antenna diversity architecture).
- Following channel(s) was (were) selected for the final test as listed below.

CDD Mode						
MODE	Freq. BAND (MHz)	AVAILABLE CHANNEL	TESTED CHANNEL	MODULATION TECHNOLOGY	MODULATION TYPE	DATA RATE (Mbps)
802.11a	5180-5240	36 to 48	36, 40, 48	OFDM	BPSK	6
802.11a	5260-5320	52 to 64	52, 60, 64	OFDM	BPSK	6
802.11a	5500-5720	100 to 144	100, 116, 140, 144	OFDM	BPSK	6
802.11a	5745-5825	149 to 165	149, 157, 165	OFDM	BPSK	6
Beamforming Mode						
MODE	Freq. BAND (MHz)	AVAILABLE CHANNEL	TESTED CHANNEL	MODULATION TECHNOLOGY	MODULATION TYPE	DATA RATE (Mbps)
802.11ac (VHT20)	5180-5240	36 to 48	36, 40, 48	OFDM	BPSK	6.5
802.11ac (VHT40)		38 to 46	38, 46	OFDM	BPSK	13.5
802.11ac (VHT80)		42	42	OFDM	BPSK	29.3
802.11ac (VHT20)	5260-5320	52 to 64	52, 60, 64	OFDM	BPSK	6.5
802.11ac (VHT40)		54 to 62	54, 62	OFDM	BPSK	13.5
802.11ac (VHT80)		58	58	OFDM	BPSK	29.3
802.11ac (VHT20)	5500-5720	100 to 144	100, 116, 140, 144	OFDM	BPSK	6.5
802.11ac (VHT40)		102 to 142	102, 110, 134, 142	OFDM	BPSK	13.5
802.11ac (VHT80)		106 to 138	106, 122, 138	OFDM	BPSK	29.3
802.11ac (VHT20)	5745-5825	149 to 165	149, 157, 165	OFDM	BPSK	6.5
802.11ac (VHT40)		151 to 159	151, 159	OFDM	BPSK	13.5
802.11ac (VHT80)		155	155	OFDM	BPSK	29.3

**Radiated Emission Test (Below 1GHz):**

- Pre-Scan has been conducted to determine the worst-case mode from all possible combinations between available modulations, data rates and antenna ports (if EUT with antenna diversity architecture).
- Following channel(s) was (were) selected for the final test as listed below.

<b>Beamforming Mode</b>						
MODE	Freq. BAND (MHz)	AVAILABLE CHANNEL	TESTED CHANNEL	MODULATION TECHNOLOGY	MODULATION TYPE	DATA RATE (Mbps)
802.11ac (VHT40)	5180-5240	38 to 46	151	OFDM	BPSK	13.5
	5260-5320	54 to 62				
	5500-5720	102 to 142				
	5745-5825	151 to 159				

**Power Line Conducted Emission Test:**

- Pre-Scan has been conducted to determine the worst-case mode from all possible combinations between available modulations, data rates and antenna ports (if EUT with antenna diversity architecture).
- Following channel(s) was (were) selected for the final test as listed below.

<b>Beamforming Mode</b>						
MODE	Freq. BAND (MHz)	AVAILABLE CHANNEL	TESTED CHANNEL	MODULATION TECHNOLOGY	MODULATION TYPE	DATA RATE (Mbps)
802.11ac (VHT40)	5180-5240	38 to 46	151	OFDM	BPSK	13.5
	5260-5320	54 to 62				
	5500-5720	102 to 142				
	5745-5825	151 to 159				

### Antenna Port Conducted Measurement:

- This item includes all test value of each mode, but only includes spectrum plot of worst value of each mode.
- Pre-Scan has been conducted to determine the worst-case mode from all possible combinations between available modulations, data rates and antenna ports (if EUT with antenna diversity architecture).
- Following channel(s) was (were) selected for the final test as listed below.

CDD Mode						
MODE	Freq. BAND (MHz)	AVAILABLE CHANNEL	TESTED CHANNEL	MODULATION TECHNOLOGY	MODULATION TYPE	DATA RATE (Mbps)
802.11a	5180-5240	36 to 48	36, 40, 48	OFDM	BPSK	6
	5260-5320	52 to 64	52, 60, 64			
	5500-5720	100 to 144	100, 116, 140, 144			
	5745-5825	149 to 165	149, 157, 165			
Beamforming Mode						
MODE	Freq. BAND (MHz)	AVAILABLE CHANNEL	TESTED CHANNEL	MODULATION TECHNOLOGY	MODULATION TYPE	DATA RATE (Mbps)
802.11ac (VHT20)	5180-5240	36 to 48	36, 40, 48	OFDM	BPSK	6.5
802.11ac (VHT40)		38 to 46	38, 46	OFDM	BPSK	13.5
802.11ac (VHT80)		42	42	OFDM	BPSK	29.3
802.11ac (VHT20)	5260-5320	52 to 64	52, 60, 64	OFDM	BPSK	6.5
802.11ac (VHT40)		54 to 62	54, 62	OFDM	BPSK	13.5
802.11ac (VHT80)		58	58	OFDM	BPSK	29.3
802.11ac (VHT20)	5500-5720	100 to 144	100, 116, 140, 144	OFDM	BPSK	6.5
802.11ac (VHT40)		102 to 142	102, 110, 134, 142	OFDM	BPSK	13.5
802.11ac (VHT80)		106 to 138	106, 122, 138	OFDM	BPSK	29.3
802.11ac (VHT20)	5745-5825	149 to 165	149, 157, 165	OFDM	BPSK	6.5
802.11ac (VHT40)		151 to 159	151, 159	OFDM	BPSK	13.5
802.11ac (VHT80)		155	155	OFDM	BPSK	29.3

### Test Condition:

Applicable To	Environmental Conditions	Input Power	Tested By
RE $\geq$ 1G	25deg. C, 65%RH	120Vac, 60Hz	Robert Cheng
RE $<$ 1G	25deg. C, 68%RH	120Vac, 60Hz	Jyunchun Lin
PLC	25deg. C, 75%RH	120Vac, 60Hz	Andy Ho
APCM	24deg. C, 61%RH	120Vac, 60Hz	Robert Cheng

### 3.3 Duty Cycle of Test Signal

Duty cycle of test signal is  $\geq 98\%$ , duty factor is not required.

**802.11a:** Duty cycle =  $2.695 \text{ ms} / 2.739 \text{ ms} = 0.984$

**802.11ac (VHT20):** Duty cycle =  $12.356 \text{ ms} / 12.408 \text{ ms} = 0.996$

**802.11ac (VHT40):** Duty cycle =  $5.968 \text{ ms} / 6.028 \text{ ms} = 0.99$

**802.11ac (VHT80):** Duty cycle =  $2.78 \text{ ms} / 2.83 \text{ ms} = 0.982$

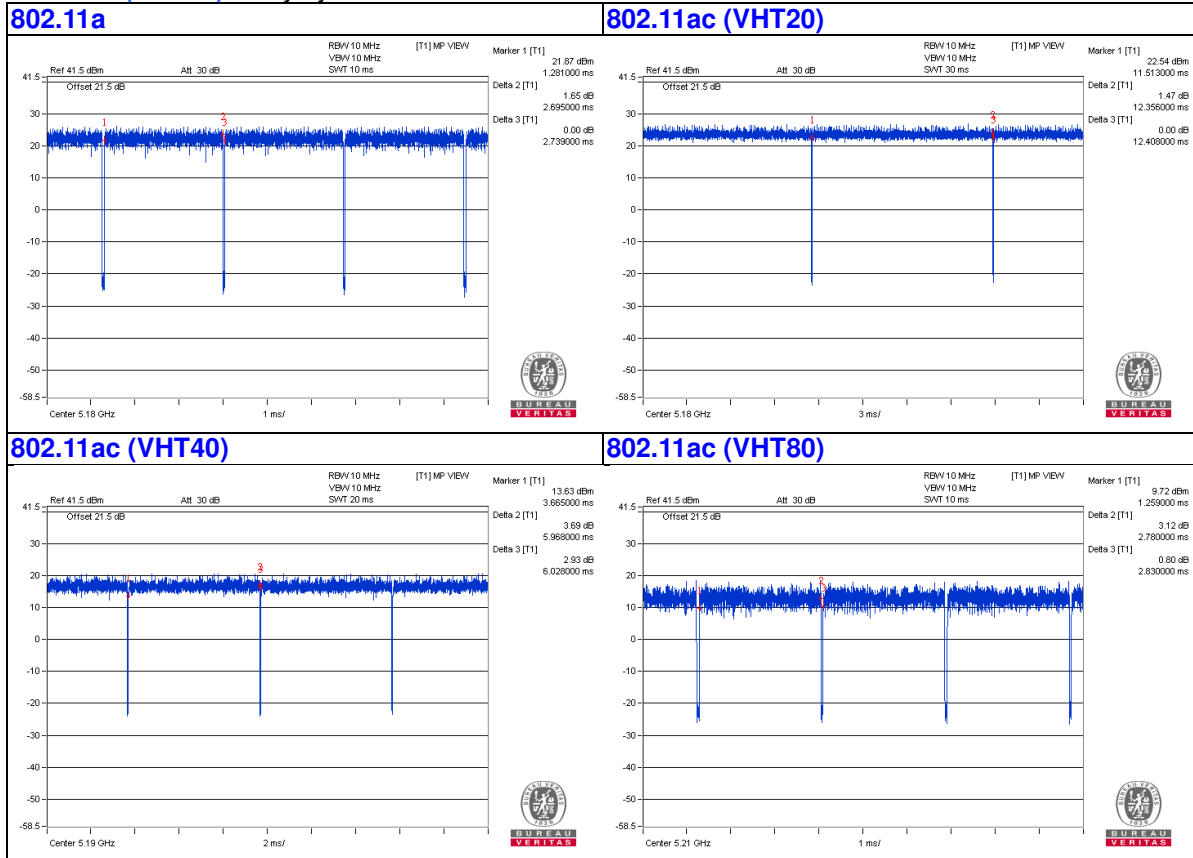

### 3.4 Description of Support Units

The EUT has been tested as an independent unit together with other necessary accessories or support units. The following support units or accessories were used to form a representative test configuration during the tests.

ID	Product	Brand	Model No.	Serial No.	FCC ID	Remarks
A.	Laptop	DELL	E5430	HYV4VY1	FCC DoC	Provided by Lab
B.	iPod	Apple	MD778TA/A	MD778TA/A	NA	Provided by Lab
C.	TV	TATUNG	DK-2410	NA	NA	Provided by Lab
D.	Digital to Analogue Audio Converter	LINDA	70468	201407290025	NA	Provided by Lab

Note:

1. All power cords of the above support units are non-shielded (1.8m).

ID	Descriptions	Qty.	Length (m)	Shielding (Yes/No)	Cores (Qty.)	Remarks
1.	USB Cable	1	0.1	Yes	0	Provided by Lab
2.	IR Cable	1	1	Yes	0	Supplied by client
3.	Fiber Cable	1	1.5	No	0	Supplied by client
4.	Coaxial Cable	1	10	Yes	0	Provided by Lab
5.	RJ-45 Cable	1	10	No	0	Provided by Lab
6.	DC Cable	1	1.5	No	0	Supplied by client
7.	Vedio Cable	1	2	Yes	0	Supplied by client
8.	Video to Y/Pb/Pr Cable	1	0.2	Yes	0	Supplied by client
9.	Vedio Cable	1	2	Yes	0	Supplied by client
10.	HDMI Cable	1	1.5	Yes	0	Supplied by client



### 3.4.1 Configuration of System under Test

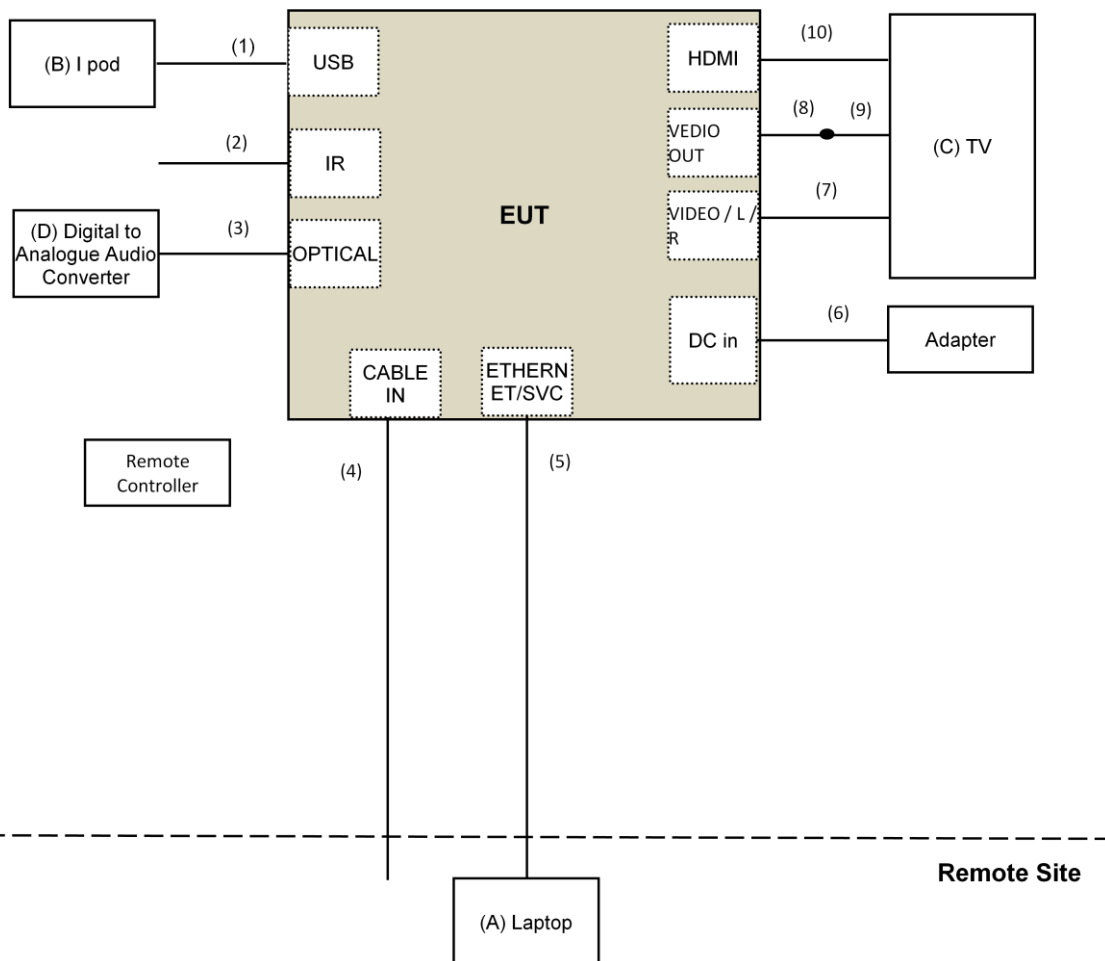

### 3.5 General Description of Applied Standard

The EUT is a RF Product. According to the specifications of the manufacturer, it must comply with the requirements of the following standards:

**FCC Part 15, Subpart E (15.407)**  
**KDB 789033 D02 General UNII Test Procedure New Rules v01r03**  
**KDB 662911 D01 Multiple Transmitter Output v02r01**  
**ANSI C63.10-2013**

All test items have been performed and recorded as per the above standards.

**NOTE:** The EUT has been verified to comply with the requirements of FCC Part 15, Subpart B, Class B (DoC). The test report has been issued separately.

## 4 Test Types and Results

### 4.1 Radiated Emission and Bandedge Measurement

#### 4.1.1 Limits of Radiated Emission and Bandedge Measurement

Radiated emissions which fall in the restricted bands must comply with the radiated emission limits specified as below table.

Frequencies (MHz)	Field Strength (microvolts/meter)	Measurement Distance (meters)
0.009 ~ 0.490	2400/F(kHz)	300
0.490 ~ 1.705	24000/F(kHz)	30
1.705 ~ 30.0	30	30
30 ~ 88	100	3
88 ~ 216	150	3
216 ~ 960	200	3
Above 960	500	3

#### NOTE:

1. The lower limit shall apply at the transition frequencies.
2. Emission level (dBuV/m) = 20 log Emission level (uV/m).
3. For frequencies above 1000MHz, the field strength limits are based on average detector, however, the peak field strength of any emission shall not exceed the maximum permitted average limits, specified above by more than 20dB under any condition of modulation.

Limits of unwanted emission out of the restricted bands

Applicable To		Limit	
KDB 789033 D02 General UNII Test Procedure New Rules v01r03		Field Strength at 3m	
		PK:74 (dBμV/m)	AV:54 (dBμV/m)
Frequency Band	Applicable To	EIRP Limit	Equivalent Field Strength at 3m
5150~5250 MHz	15.407(b)(1)	PK:-27 (dBm/MHz)	PK:68.2(dBμV/m)
5250~5350 MHz	15.407(b)(2)		
5470~5725 MHz	15.407(b)(3)		
5725~5850 MHz	<input checked="" type="checkbox"/> 15.407(b)(4)(i)	PK:-27 (dBm/MHz) <sup>*1</sup> PK:10 (dBm/MHz) <sup>*2</sup> PK:15.6 (dBm/MHz) <sup>*3</sup> PK:27 (dBm/MHz) <sup>*4</sup>	PK: 68.2(dBμV/m) <sup>*1</sup> PK:105.2 (dBμV/m) <sup>*2</sup> PK: 110.8(dBμV/m) <sup>*3</sup> PK:122.2 (dBμV/m) <sup>*4</sup>
	<input type="checkbox"/> 15.407(b)(4)(ii)	Emission limits in section 15.247(d)	
<sup>*1</sup> beyond 75 MHz or more above of the band edge.		<sup>*2</sup> below the band edge increasing linearly to 10 dBm/MHz at 25 MHz above.	
<sup>*3</sup> below the band edge increasing linearly to a level of 15.6 dBm/MHz at 5 MHz above.		<sup>*4</sup> from 5 MHz above or below the band edge increasing linearly to a level of 27 dBm/MHz at the band edge.	

#### Note:

The following formula is used to convert the equipment isotropic radiated power (eirp) to field strength:

$$E = \frac{1000000\sqrt{30P}}{3} \mu\text{V/m, where } P \text{ is the eirp (Watts).}$$

## 4.1.2 Test Instruments

DESCRIPTION & MANUFACTURER	MODEL NO.	SERIAL NO.	CALIBRATED DATE	CALIBRATED UNTIL
Test Receiver Agilent	N9038A	MY50010156	Aug. 18, 2016	Aug. 17, 2017
Pre-Amplifier <sup>(*)</sup> EMCI	EMC001340	980142	Jan. 20, 2016	Jan. 19, 2018
Loop Antenna <sup>(*)</sup> Electro-Metrics	EM-6879	264	Dec. 16, 2014	Dec. 15, 2016
RF Cable	NA	LOOPCAB-001 LOOPCAB-002	Jan. 18, 2016	Jan. 17, 2017
Pre-Amplifier Mini-Circuits	ZFL-1000VH2 B	AMP-ZFL-05	May 07, 2016	May 06, 2017
Trilog Broadband Antenna SCHWARZBECK	VULB 9168	9168-156	Jan. 04, 2016	Jan. 03, 2017
RF Cable	8D	966-3-1 966-3-2 966-3-3	Apr. 02, 2016	Apr. 01, 2017
Fixed attenuator Mini-Circuits	UNAT-5+	PAD-3m-3-01	Oct. 05, 2016	Oct. 04, 2017
Horn_Antenna SCHWARZBECK	BBHA9120-D	9120D-406	Jan. 20, 2016	Jan. 19, 2017
Pre-Amplifier Agilent	8449B	3008A02465	Apr. 05, 2016	Apr. 04, 2017
RF Cable	EMC104-SM- SM-2000 EMC104-SM- SM-5000 EMC104-SM- SM-5000	150317 150321 150322	Mar. 30, 2016	Mar. 29, 2017
Spectrum Analyzer Keysight	N9030A	MY54490520	July 29, 2016	July 28, 2017
Pre-Amplifier EMCI	EMC184045	980143	Jan. 15, 2016	Jan. 14, 2017
Horn_Antenna SCHWARZBECK	BBHA 9170	BBHA9170608	Jan. 08, 2016	Jan. 07, 2017
RF Cable	SUCOFLEX 102	36432/2 36441/2	Jan. 16, 2016	Jan. 15, 2017
Software	ADT_Radiated _V8.7.08	NA	NA	NA
Antenna Tower & Turn Table Max-Full	MF-7802	MF780208406	NA	NA
Boresight Antenna Fixture	FBA-01	FBA-SIP01	NA	NA
Spectrum Analyzer R&S	FSP40	100036	Jan. 27, 2016	Jan. 26, 2017
AC Power Source Extech Electronics	6502	1140503	NA	NA
Temperature & Humidity Chamber TERCHY	MHU-225AU	911033	Dec. 03, 2015	Dec. 02, 2016
Power meter Anritsu	ML2495A	0824006	May 26, 2016	May 25, 2017

**Note:**

1. The calibration interval of the above test instruments is 12 months and the calibrations are traceable to NML/ROC and NIST/USA.
2. \*The calibration interval of the above test instruments is 24 months and the calibrations are traceable to NML/ROC and NIST/USA.
3. The horn antenna, preamplifier (model: 8449B) are used only for the measurement of emission frequency above 1GHz if tested.
4. The test was performed in 966 Chamber No. 3.
5. The FCC Site Registration No. is 147459
6. The CANADA Site Registration No. is 20331-1
7. Tested Date: Nov. 16 to 22, 2016

#### 4.1.3 Test Procedure

##### **For Radiated emission below 30MHz**

- a. The EUT was placed on the top of a rotating table 0.8 meters above the ground at a 3 meter chamber room. The table was rotated 360 degrees to determine the position of the highest radiation.
- b. The EUT was set 3 meters away from the interference-receiving antenna, which was mounted on the top of a variable-height antenna tower.
- c. Both X and Y axes of the antenna are set to make the measurement.
- d. For each suspected emission, the EUT was arranged to its worst case and the rotatable table was turned from 0 degrees to 360 degrees to find the maximum reading.
- e. The test-receiver system was set to Quasi-Peak Detect Function and Specified Bandwidth with Maximum Hold Mode.

##### **NOTE:**

1. The resolution bandwidth and video bandwidth of test receiver/spectrum analyzer is 9kHz at frequency below 30MHz.

##### **For Radiated emission above 30MHz**

- a. The EUT was placed on the top of a rotating table 0.8 meters (for 30MHz ~ 1GHz) / 1.5 meters (for above 1GHz) above the ground at 3 meter chamber room for test. The table was rotated 360 degrees to determine the position of the highest radiation.
- b. The EUT was set 3 meters away from the interference-receiving antenna, which was mounted on the top of a variable-height antenna tower.
- c. The height of antenna is varied from one meter to four meters above the ground to determine the maximum value of the field strength. Both horizontal and vertical polarizations of the antenna are set to make the measurement.
- d. For each suspected emission, the EUT was arranged to its worst case and then the antenna was tuned to heights from 1 meter to 4 meters and the rotatable table was turned from 0 degrees to 360 degrees to find the maximum reading.
- e. The test-receiver system was set to quasi-peak detect function and specified bandwidth with maximum hold mode when the test frequency is below 1 GHz.
- f. The test-receiver system was set to peak and average detect function and specified bandwidth with maximum hold mode when the test frequency is above 1 GHz. If the peak reading value also meets average limit, measurement with the average detector is unnecessary.

##### **Note:**

1. The resolution bandwidth and video bandwidth of test receiver/spectrum analyzer is 120kHz for Quasi-peak detection (QP) at frequency below 1GHz.
2. The resolution bandwidth of test receiver/spectrum analyzer is 1 MHz and the video bandwidth is 3 MHz for Peak detection (PK) at frequency above 1GHz.
3. The resolution bandwidth of test receiver/spectrum analyzer is 1MHz and the video bandwidth is  $\geq 1/T$  (Duty cycle < 98%) or 10Hz (Duty cycle  $\geq 98\%$ ) for Average detection (AV) at frequency above 1GHz.
4. All modes of operation were investigated and the worst-case emissions are reported.

#### 4.1.4 Deviation from Test Standard

No deviation.

#### 4.1.5 Test Setup

##### For Radiated emission below 30MHz

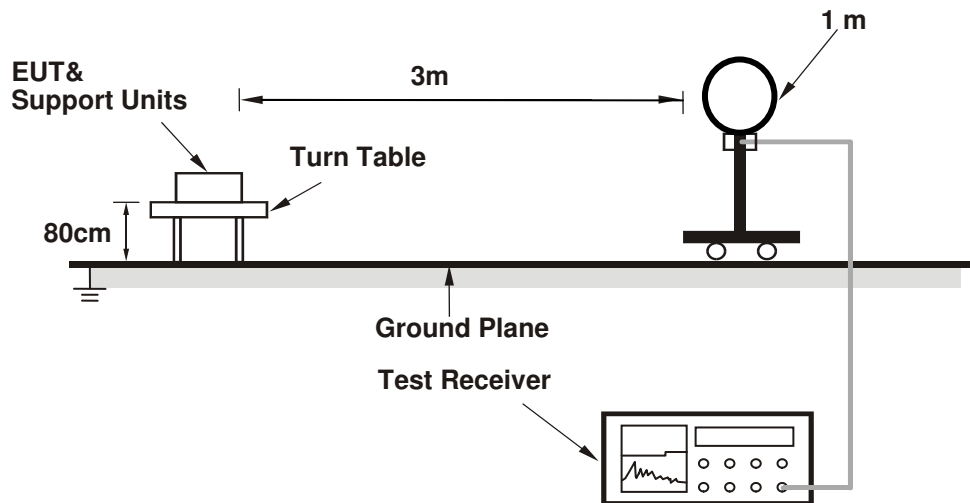

##### For Radiated emission 30MHz to 1GHz

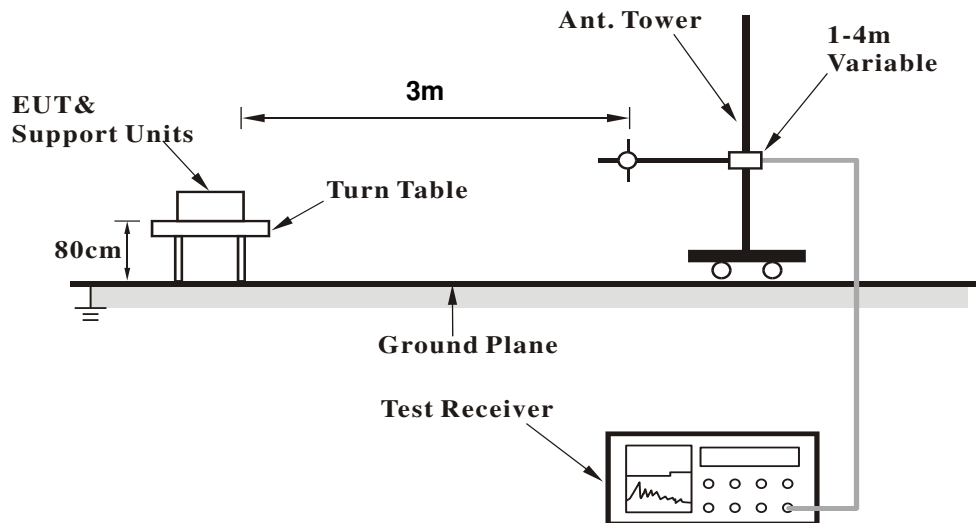

### For Radiated emission above 1GHz

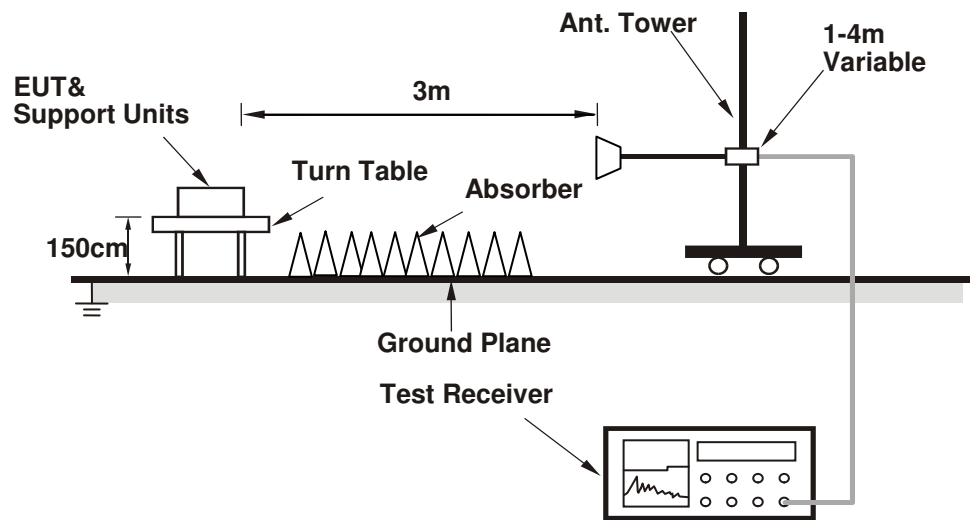

For the actual test configuration, please refer to the attached file (Test Setup Photo).

#### 4.1.6 EUT Operating Condition

- a. Connected the EUT with the Laptop which is placed on remote site.
- b. Controlling software (Telnet paste "JS72 5G WiFi CDD command .txt") has been activated to set the EUT on specific status.



4.1.7 Test Results

Above 1GHz Data:

802.11a

<b>CHANNEL</b>	TX Channel 36	<b>DETECTOR FUNCTION</b>	Peak (PK)
<b>FREQUENCY RANGE</b>	1GHz ~ 40GHz		Average (AV)

ANTENNA POLARITY & TEST DISTANCE: HORIZONTAL AT 3 M								
NO.	FREQ. (MHz)	EMISSION LEVEL (dBuV/m)	LIMIT (dBuV/m)	MARGIN (dB)	ANTENNA HEIGHT (m)	TABLE ANGLE (Degree)	RAW VALUE (dBuV)	CORRECTION FACTOR (dB/m)
1	5150.00	67.2 PK	74.0	-6.8	1.00 H	196	64.2	3.0
2	5150.00	50.9 AV	54.0	-3.1	1.00 H	196	47.9	3.0
3	*5180.00	116.6 PK			1.00 H	196	113.5	3.1
4	*5180.00	106.2 AV			1.00 H	196	103.1	3.1
5	#10360.00	54.9 PK	74.0	-19.1	1.09 H	205	41.3	13.6
6	#10360.00	41.3 AV	54.0	-12.7	1.09 H	205	27.7	13.6
7	15540.00	52.4 PK	74.0	-21.6	1.42 H	177	36.7	15.7
8	15540.00	40.0 AV	54.0	-14.0	1.42 H	177	24.3	15.7

ANTENNA POLARITY & TEST DISTANCE: VERTICAL AT 3 M								
NO.	FREQ. (MHz)	EMISSION LEVEL (dBuV/m)	LIMIT (dBuV/m)	MARGIN (dB)	ANTENNA HEIGHT (m)	TABLE ANGLE (Degree)	RAW VALUE (dBuV)	CORRECTION FACTOR (dB/m)
1	5150.00	64.5 PK	74.0	-9.5	2.86 V	300	61.5	3.0
2	5150.00	49.0 AV	54.0	-5.0	2.86 V	300	46.0	3.0
3	*5180.00	112.2 PK			2.86 V	300	109.1	3.1
4	*5180.00	101.1 AV			2.86 V	300	98.0	3.1
5	#10360.00	50.2 PK	74.0	-23.8	1.62 V	176	36.6	13.6
6	#10360.00	38.7 AV	54.0	-15.3	1.62 V	176	25.1	13.6
7	15540.00	53.0 PK	74.0	-21.0	2.15 V	301	37.3	15.7
8	15540.00	40.7 AV	54.0	-13.3	2.15 V	301	25.0	15.7

REMARKS:

1. Emission Level(dBuV/m) = Raw Value(dBuV) + Correction Factor(dB/m)
2. Correction Factor(dB/m) = Antenna Factor(dB/m) + Cable Factor(dB) – Pre-Amplifier Factor(dB)
3. The other emission levels were very low against the limit.
4. Margin value = Emission Level – Limit value
5. " \* ": Fundamental frequency.
6. " # ": The radiated frequency is out of the restricted band.

<b>CHANNEL</b>	TX Channel 40	<b>DETECTOR FUNCTION</b>	Peak (PK)
<b>FREQUENCY RANGE</b>	1GHz ~ 40GHz		Average (AV)

**ANTENNA POLARITY & TEST DISTANCE: HORIZONTAL AT 3 M**

NO.	FREQ. (MHz)	EMISSION LEVEL (dBuV/m)	LIMIT (dBuV/m)	MARGIN (dB)	ANTENNA HEIGHT (m)	TABLE ANGLE (Degree)	RAW VALUE (dBuV)	CORRECTION FACTOR (dB/m)
1	*5200.00	116.5 PK			1.00 H	211	113.4	3.1
2	*5200.00	106.3 AV			1.00 H	211	103.2	3.1
3	#10400.00	54.9 PK	74.0	-19.1	1.05 H	197	41.3	13.6
4	#10400.00	41.6 AV	54.0	-12.4	1.05 H	197	28.0	13.6
5	15600.00	51.7 PK	74.0	-22.3	1.40 H	160	36.0	15.7
6	15600.00	39.6 AV	54.0	-14.4	1.40 H	160	23.9	15.7

**ANTENNA POLARITY & TEST DISTANCE: VERTICAL AT 3 M**

NO.	FREQ. (MHz)	EMISSION LEVEL (dBuV/m)	LIMIT (dBuV/m)	MARGIN (dB)	ANTENNA HEIGHT (m)	TABLE ANGLE (Degree)	RAW VALUE (dBuV)	CORRECTION FACTOR (dB/m)
1	*5200.00	111.8 PK			2.89 V	306	108.7	3.1
2	*5200.00	100.7 AV			2.89 V	306	97.6	3.1
3	#10400.00	50.3 PK	74.0	-23.7	1.62 V	191	36.7	13.6
4	#10400.00	38.7 AV	54.0	-15.3	1.62 V	191	25.1	13.6
5	15600.00	52.6 PK	74.0	-21.4	2.16 V	313	36.9	15.7
6	15600.00	40.6 AV	54.0	-13.4	2.16 V	313	24.9	15.7

**REMARKS:**

1. Emission Level(dBuV/m) = Raw Value(dBuV) + Correction Factor(dB/m)
2. Correction Factor(dB/m) = Antenna Factor(dB/m) + Cable Factor(dB) – Pre-Amplifier Factor(dB)
3. The other emission levels were very low against the limit.
4. Margin value = Emission Level – Limit value
5. " \* ": Fundamental frequency.
6. " # ": The radiated frequency is out of the restricted band.

<b>CHANNEL</b>	TX Channel 48	<b>DETECTOR FUNCTION</b>	Peak (PK)
<b>FREQUENCY RANGE</b>	1GHz ~ 40GHz		Average (AV)

**ANTENNA POLARITY & TEST DISTANCE: HORIZONTAL AT 3 M**

NO.	FREQ. (MHz)	EMISSION LEVEL (dBuV/m)	LIMIT (dBuV/m)	MARGIN (dB)	ANTENNA HEIGHT (m)	TABLE ANGLE (Degree)	RAW VALUE (dBuV)	CORRECTION FACTOR (dB/m)
1	*5240.00	117.4 PK			1.03 H	185	114.2	3.2
2	*5240.00	106.7 AV			1.03 H	185	103.5	3.2
3	5350.00	62.8 PK	74.0	-11.2	1.03 H	185	59.3	3.5
4	5350.00	47.2 AV	54.0	-6.8	1.03 H	185	43.7	3.5
5	#10480.00	55.1 PK	74.0	-18.9	1.04 H	200	41.1	14.0
6	#10480.00	41.6 AV	54.0	-12.4	1.04 H	200	27.6	14.0
7	15720.00	51.7 PK	74.0	-22.3	1.45 H	165	36.3	15.4
8	15720.00	39.6 AV	54.0	-14.4	1.45 H	165	24.2	15.4

**ANTENNA POLARITY & TEST DISTANCE: VERTICAL AT 3 M**

NO.	FREQ. (MHz)	EMISSION LEVEL (dBuV/m)	LIMIT (dBuV/m)	MARGIN (dB)	ANTENNA HEIGHT (m)	TABLE ANGLE (Degree)	RAW VALUE (dBuV)	CORRECTION FACTOR (dB/m)
1	*5240.00	112.2 PK			2.91 V	310	109.0	3.2
2	*5240.00	100.8 AV			2.91 V	310	97.6	3.2
3	5350.00	62.2 PK	74.0	-11.8	2.91 V	310	58.7	3.5
4	5350.00	46.8 AV	54.0	-7.2	2.91 V	310	43.3	3.5
5	#10480.00	50.0 PK	74.0	-24.0	1.63 V	161	36.0	14.0
6	#10480.00	38.6 AV	54.0	-15.4	1.63 V	161	24.6	14.0
7	15720.00	52.9 PK	74.0	-21.1	2.20 V	288	37.5	15.4
8	15720.00	40.7 AV	54.0	-13.3	2.20 V	288	25.3	15.4

**REMARKS:**

1. Emission Level(dBuV/m) = Raw Value(dBuV) + Correction Factor(dB/m)
2. Correction Factor(dB/m) = Antenna Factor(dB/m) + Cable Factor(dB) – Pre-Amplifier Factor(dB)
3. The other emission levels were very low against the limit.
4. Margin value = Emission Level – Limit value
5. " \* ": Fundamental frequency.
6. " # ": The radiated frequency is out of the restricted band.

<b>CHANNEL</b>	TX Channel 52	<b>DETECTOR FUNCTION</b>	Peak (PK)
<b>FREQUENCY RANGE</b>	1GHz ~ 40GHz		Average (AV)

**ANTENNA POLARITY & TEST DISTANCE: HORIZONTAL AT 3 M**

NO.	FREQ. (MHz)	EMISSION LEVEL (dBuV/m)	LIMIT (dBuV/m)	MARGIN (dB)	ANTENNA HEIGHT (m)	TABLE ANGLE (Degree)	RAW VALUE (dBuV)	CORRECTION FACTOR (dB/m)
1	5150.00	62.0 PK	74.0	-12.0	1.06 H	187	59.0	3.0
2	5150.00	46.4 AV	54.0	-7.6	1.06 H	187	43.4	3.0
3	*5260.00	116.6 PK			1.06 H	187	113.3	3.3
4	*5260.00	106.5 AV			1.06 H	187	103.2	3.3
5	#10520.00	54.5 PK	74.0	-19.5	1.08 H	197	40.4	14.1
6	#10520.00	41.2 AV	54.0	-12.8	1.08 H	197	27.1	14.1
7	15780.00	51.9 PK	74.0	-22.1	1.43 H	173	36.7	15.2
8	15780.00	39.6 AV	54.0	-14.4	1.43 H	173	24.4	15.2

**ANTENNA POLARITY & TEST DISTANCE: VERTICAL AT 3 M**

NO.	FREQ. (MHz)	EMISSION LEVEL (dBuV/m)	LIMIT (dBuV/m)	MARGIN (dB)	ANTENNA HEIGHT (m)	TABLE ANGLE (Degree)	RAW VALUE (dBuV)	CORRECTION FACTOR (dB/m)
1	5150.00	61.8 PK	74.0	-12.2	2.81 V	308	58.8	3.0
2	5150.00	46.4 AV	54.0	-7.6	2.81 V	308	43.4	3.0
3	*5260.00	112.3 PK			2.81 V	308	109.0	3.3
4	*5260.00	101.0 AV			2.81 V	308	97.7	3.3
5	#10520.00	50.4 PK	74.0	-23.6	1.58 V	169	36.3	14.1
6	#10520.00	38.8 AV	54.0	-15.2	1.58 V	169	24.7	14.1
7	15780.00	52.6 PK	74.0	-21.4	2.10 V	308	37.4	15.2
8	15780.00	40.5 AV	54.0	-13.5	2.10 V	308	25.3	15.2

**REMARKS:**

1. Emission Level(dBuV/m) = Raw Value(dBuV) + Correction Factor(dB/m)
2. Correction Factor(dB/m) = Antenna Factor(dB/m) + Cable Factor(dB) – Pre-Amplifier Factor(dB)
3. The other emission levels were very low against the limit.
4. Margin value = Emission Level – Limit value
5. " \* ": Fundamental frequency.
6. " # ": The radiated frequency is out of the restricted band.

<b>CHANNEL</b>	TX Channel 60	<b>DETECTOR FUNCTION</b>	Peak (PK)
<b>FREQUENCY RANGE</b>	1GHz ~ 40GHz		Average (AV)

**ANTENNA POLARITY & TEST DISTANCE: HORIZONTAL AT 3 M**

NO.	FREQ. (MHz)	EMISSION LEVEL (dBuV/m)	LIMIT (dBuV/m)	MARGIN (dB)	ANTENNA HEIGHT (m)	TABLE ANGLE (Degree)	RAW VALUE (dBuV)	CORRECTION FACTOR (dB/m)
1	*5300.00	116.8 PK			1.00 H	189	113.5	3.3
2	*5300.00	106.6 AV			1.00 H	189	103.3	3.3
3	10600.00	55.4 PK	74.0	-18.6	1.02 H	197	41.1	14.3
4	10600.00	41.9 AV	54.0	-12.1	1.02 H	197	27.6	14.3
5	15900.00	51.3 PK	74.0	-22.7	1.45 H	167	36.2	15.1
6	15900.00	39.2 AV	54.0	-14.8	1.45 H	167	24.1	15.1

**ANTENNA POLARITY & TEST DISTANCE: VERTICAL AT 3 M**

NO.	FREQ. (MHz)	EMISSION LEVEL (dBuV/m)	LIMIT (dBuV/m)	MARGIN (dB)	ANTENNA HEIGHT (m)	TABLE ANGLE (Degree)	RAW VALUE (dBuV)	CORRECTION FACTOR (dB/m)
1	*5300.00	112.8 PK			2.87 V	287	109.5	3.3
2	*5300.00	101.6 AV			2.87 V	287	98.3	3.3
3	10600.00	50.1 PK	74.0	-23.9	1.66 V	164	35.8	14.3
4	10600.00	38.7 AV	54.0	-15.3	1.66 V	164	24.4	14.3
5	15900.00	52.6 PK	74.0	-21.4	2.18 V	297	37.5	15.1
6	15900.00	40.4 AV	54.0	-13.6	2.18 V	297	25.3	15.1

**REMARKS:**

1. Emission Level(dBuV/m) = Raw Value(dBuV) + Correction Factor(dB/m)
2. Correction Factor(dB/m) = Antenna Factor(dB/m) + Cable Factor(dB) – Pre-Amplifier Factor(dB)
3. The other emission levels were very low against the limit.
4. Margin value = Emission Level – Limit value
5. " \* ": Fundamental frequency.

<b>CHANNEL</b>	TX Channel 64	<b>DETECTOR FUNCTION</b>	Peak (PK)
<b>FREQUENCY RANGE</b>	1GHz ~ 40GHz		Average (AV)

**ANTENNA POLARITY & TEST DISTANCE: HORIZONTAL AT 3 M**

NO.	FREQ. (MHz)	EMISSION LEVEL (dBuV/m)	LIMIT (dBuV/m)	MARGIN (dB)	ANTENNA HEIGHT (m)	TABLE ANGLE (Degree)	RAW VALUE (dBuV)	CORRECTION FACTOR (dB/m)
1	*5320.00	116.7 PK			1.03 H	207	113.2	3.5
2	*5320.00	106.1 AV			1.03 H	207	102.6	3.5
3	5350.00	66.2 PK	74.0	-7.8	1.03 H	207	62.7	3.5
4	5350.00	52.4 AV	54.0	-1.6	1.03 H	207	48.9	3.5
5	10640.00	55.1 PK	74.0	-18.9	1.04 H	205	40.8	14.3
6	10640.00	41.6 AV	54.0	-12.4	1.04 H	205	27.3	14.3
7	15960.00	52.1 PK	74.0	-21.9	1.42 H	178	37.0	15.1
8	15960.00	39.7 AV	54.0	-14.3	1.42 H	178	24.6	15.1

**ANTENNA POLARITY & TEST DISTANCE: VERTICAL AT 3 M**

NO.	FREQ. (MHz)	EMISSION LEVEL (dBuV/m)	LIMIT (dBuV/m)	MARGIN (dB)	ANTENNA HEIGHT (m)	TABLE ANGLE (Degree)	RAW VALUE (dBuV)	CORRECTION FACTOR (dB/m)
1	*5320.00	112.2 PK			2.85 V	288	108.7	3.5
2	*5320.00	101.1 AV			2.85 V	288	97.6	3.5
3	5350.00	64.1 PK	74.0	-9.9	2.85 V	288	60.6	3.5
4	5350.00	48.6 AV	54.0	-5.4	2.85 V	288	45.1	3.5
5	10640.00	50.2 PK	74.0	-23.8	1.62 V	166	35.9	14.3
6	10640.00	38.6 AV	54.0	-15.4	1.62 V	166	24.3	14.3
7	15960.00	52.8 PK	74.0	-21.2	2.15 V	311	37.7	15.1
8	15960.00	40.5 AV	54.0	-13.5	2.15 V	311	25.4	15.1

**REMARKS:**

1. Emission Level(dBuV/m) = Raw Value(dBuV) + Correction Factor(dB/m)
2. Correction Factor(dB/m) = Antenna Factor(dB/m) + Cable Factor(dB) – Pre-Amplifier Factor(dB)
3. The other emission levels were very low against the limit.
4. Margin value = Emission Level – Limit value
5. " \* ": Fundamental frequency.

<b>CHANNEL</b>	TX Channel 100	<b>DETECTOR FUNCTION</b>	Peak (PK)
<b>FREQUENCY RANGE</b>	1GHz ~ 40GHz		Average (AV)

**ANTENNA POLARITY & TEST DISTANCE: HORIZONTAL AT 3 M**

NO.	FREQ. (MHz)	EMISSION LEVEL (dBuV/m)	LIMIT (dBuV/m)	MARGIN (dB)	ANTENNA HEIGHT (m)	TABLE ANGLE (Degree)	RAW VALUE (dBuV)	CORRECTION FACTOR (dB/m)
1	#5470.00	69.4 PK	74.0	-4.6	1.00 H	194	65.7	3.7
2	#5470.00	53.4 AV	54.0	-0.6	1.00 H	194	49.7	3.7
3	*5500.00	115.1 PK			1.00 H	194	111.3	3.8
4	*5500.00	103.6 AV			1.00 H	194	99.8	3.8
5	11000.00	53.2 PK	74.0	-20.8	1.03 H	206	38.0	15.2
6	11000.00	39.4 AV	54.0	-14.6	1.03 H	206	24.2	15.2
7	#16500.00	51.2 PK	74.0	-22.8	1.48 H	164	33.8	17.4
8	#16500.00	39.2 AV	54.0	-14.8	1.48 H	164	21.8	17.4

**ANTENNA POLARITY & TEST DISTANCE: VERTICAL AT 3 M**

NO.	FREQ. (MHz)	EMISSION LEVEL (dBuV/m)	LIMIT (dBuV/m)	MARGIN (dB)	ANTENNA HEIGHT (m)	TABLE ANGLE (Degree)	RAW VALUE (dBuV)	CORRECTION FACTOR (dB/m)
1	#5470.00	67.1 PK	74.0	-6.9	2.90 V	179	63.4	3.7
2	#5470.00	51.1 AV	54.0	-2.9	2.90 V	179	47.4	3.7
3	*5500.00	112.1 PK			2.90 V	179	108.3	3.8
4	*5500.00	101.0 AV			2.90 V	179	97.2	3.8
5	11000.00	50.6 PK	74.0	-23.4	1.62 V	189	35.4	15.2
6	11000.00	39.0 AV	54.0	-15.0	1.62 V	189	23.8	15.2
7	#16500.00	52.6 PK	74.0	-21.4	2.13 V	298	35.2	17.4
8	#16500.00	40.3 AV	54.0	-13.7	2.13 V	298	22.9	17.4

**REMARKS:**

1. Emission Level(dBuV/m) = Raw Value(dBuV) + Correction Factor(dB/m)
2. Correction Factor(dB/m) = Antenna Factor(dB/m) + Cable Factor(dB) – Pre-Amplifier Factor(dB)
3. The other emission levels were very low against the limit.
4. Margin value = Emission Level – Limit value
5. " \* ": Fundamental frequency.
6. " # ": The radiated frequency is out of the restricted band.

<b>CHANNEL</b>	TX Channel 116	<b>DETECTOR FUNCTION</b>	Peak (PK)
<b>FREQUENCY RANGE</b>	1GHz ~ 40GHz		Average (AV)

**ANTENNA POLARITY & TEST DISTANCE: HORIZONTAL AT 3 M**

NO.	FREQ. (MHz)	EMISSION LEVEL (dBuV/m)	LIMIT (dBuV/m)	MARGIN (dB)	ANTENNA HEIGHT (m)	TABLE ANGLE (Degree)	RAW VALUE (dBuV)	CORRECTION FACTOR (dB/m)
1	*5580.00	115.4 PK			1.01 H	207	111.5	3.9
2	*5580.00	103.6 AV			1.01 H	207	99.7	3.9
3	11160.00	54.5 PK	74.0	-19.5	1.09 H	189	39.3	15.2
4	11160.00	40.6 AV	54.0	-13.4	1.09 H	189	25.4	15.2
5	#16740.00	51.4 PK	74.0	-22.6	1.38 H	156	33.1	18.3
6	#16740.00	38.9 AV	54.0	-15.1	1.38 H	156	20.6	18.3

**ANTENNA POLARITY & TEST DISTANCE: VERTICAL AT 3 M**

NO.	FREQ. (MHz)	EMISSION LEVEL (dBuV/m)	LIMIT (dBuV/m)	MARGIN (dB)	ANTENNA HEIGHT (m)	TABLE ANGLE (Degree)	RAW VALUE (dBuV)	CORRECTION FACTOR (dB/m)
1	*5580.00	112.4 PK			2.94 V	192	108.5	3.9
2	*5580.00	101.1 AV			2.94 V	192	97.2	3.9
3	11160.00	49.8 PK	74.0	-24.2	1.58 V	191	34.6	15.2
4	11160.00	38.4 AV	54.0	-15.6	1.58 V	191	23.2	15.2
5	#16740.00	53.1 PK	74.0	-20.9	2.14 V	289	34.8	18.3
6	#16740.00	40.7 AV	54.0	-13.3	2.14 V	289	22.4	18.3

**REMARKS:**

1. Emission Level(dBuV/m) = Raw Value(dBuV) + Correction Factor(dB/m)
2. Correction Factor(dB/m) = Antenna Factor(dB/m) + Cable Factor(dB) – Pre-Amplifier Factor(dB)
3. The other emission levels were very low against the limit.
4. Margin value = Emission Level – Limit value
5. " \* ": Fundamental frequency.
6. " # ": The radiated frequency is out of the restricted band.



<b>CHANNEL</b>	TX Channel 140	<b>DETECTOR FUNCTION</b>	Peak (PK)
<b>FREQUENCY RANGE</b>	1GHz ~ 40GHz		Average (AV)

**ANTENNA POLARITY & TEST DISTANCE: HORIZONTAL AT 3 M**

NO.	FREQ. (MHz)	EMISSION LEVEL (dBuV/m)	LIMIT (dBuV/m)	MARGIN (dB)	ANTENNA HEIGHT (m)	TABLE ANGLE (Degree)	RAW VALUE (dBuV)	CORRECTION FACTOR (dB/m)
1	*5700.00	113.2 PK			1.01 H	206	109.0	4.2
2	*5700.00	102.1 AV			1.01 H	206	97.9	4.2
3	#5725.00	70.5 PK	74.0	-3.5	1.01 H	206	66.3	4.2
4	#5725.00	52.9 AV	54.0	-1.1	1.01 H	206	48.7	4.2
5	11400.00	52.9 PK	74.0	-21.1	1.03 H	203	37.4	15.5
6	11400.00	39.4 AV	54.0	-14.6	1.03 H	203	23.9	15.5
7	#17100.00	51.3 PK	74.0	-22.7	1.47 H	179	31.2	20.1
8	#17100.00	39.4 AV	54.0	-14.6	1.47 H	179	19.3	20.1

**ANTENNA POLARITY & TEST DISTANCE: VERTICAL AT 3 M**

NO.	FREQ. (MHz)	EMISSION LEVEL (dBuV/m)	LIMIT (dBuV/m)	MARGIN (dB)	ANTENNA HEIGHT (m)	TABLE ANGLE (Degree)	RAW VALUE (dBuV)	CORRECTION FACTOR (dB/m)
1	*5700.00	110.1 PK			2.61 V	154	105.9	4.2
2	*5700.00	99.0 AV			2.61 V	154	94.8	4.2
3	#5725.00	67.3 PK	74.0	-6.7	2.61 V	154	63.1	4.2
4	#5725.00	50.0 AV	54.0	-4.0	2.61 V	154	45.8	4.2
5	11400.00	50.4 PK	74.0	-23.6	1.64 V	169	34.9	15.5
6	11400.00	38.8 AV	54.0	-15.2	1.64 V	169	23.3	15.5
7	#17100.00	53.0 PK	74.0	-21.0	2.19 V	292	32.9	20.1
8	#17100.00	40.8 AV	54.0	-13.2	2.19 V	292	20.7	20.1

**REMARKS:**

1. Emission Level(dBuV/m) = Raw Value(dBuV) + Correction Factor(dB/m)
2. Correction Factor(dB/m) = Antenna Factor(dB/m) + Cable Factor(dB) – Pre-Amplifier Factor(dB)
3. The other emission levels were very low against the limit.
4. Margin value = Emission Level – Limit value
5. " \* ": Fundamental frequency.
6. " # ": The radiated frequency is out of the restricted band.

<b>CHANNEL</b>	TX Channel 144	<b>DETECTOR FUNCTION</b>	Peak (PK)
<b>FREQUENCY RANGE</b>	1GHz ~ 40GHz		Average (AV)

**ANTENNA POLARITY & TEST DISTANCE: HORIZONTAL AT 3 M**

NO.	FREQ. (MHz)	EMISSION LEVEL (dBuV/m)	LIMIT (dBuV/m)	MARGIN (dB)	ANTENNA HEIGHT (m)	TABLE ANGLE (Degree)	RAW VALUE (dBuV)	CORRECTION FACTOR (dB/m)
1	*5720.00	113.9 PK			1.00 H	208	109.7	4.2
2	*5720.00	103.0 AV			1.00 H	208	98.8	4.2
3	#5850.00	56.8 PK	74.0	-17.2	1.00 H	208	52.6	4.2
4	#5850.00	44.4 AV	54.0	-9.6	1.00 H	208	40.2	4.2
5	11440.00	50.1 PK	74.0	-23.9	1.64 H	180	34.8	15.3
6	11440.00	38.4 AV	54.0	-15.6	1.64 H	180	23.1	15.3
7	#17160.00	51.9 PK	74.0	-22.1	1.36 H	174	32.1	19.8
8	#17160.00	39.5 AV	54.0	-14.5	1.36 H	174	19.7	19.8

**ANTENNA POLARITY & TEST DISTANCE: VERTICAL AT 3 M**

NO.	FREQ. (MHz)	EMISSION LEVEL (dBuV/m)	LIMIT (dBuV/m)	MARGIN (dB)	ANTENNA HEIGHT (m)	TABLE ANGLE (Degree)	RAW VALUE (dBuV)	CORRECTION FACTOR (dB/m)
1	*5720.00	110.3 PK			2.59 V	142	106.1	4.2
2	*5720.00	99.2 AV			2.59 V	142	95.0	4.2
3	#5850.00	54.7 PK	74.0	-19.3	2.59 V	142	50.5	4.2
4	#5850.00	42.1 AV	54.0	-11.9	2.59 V	142	37.9	4.2
5	11440.00	50.3 PK	74.0	-23.7	1.68 V	191	35.0	15.3
6	11440.00	39.1 AV	54.0	-14.9	1.68 V	191	23.8	15.3
7	#17160.00	53.1 PK	74.0	-20.9	2.14 V	286	33.3	19.8
8	#17160.00	40.8 AV	54.0	-13.2	2.14 V	286	21.0	19.8

**REMARKS:**

1. Emission Level(dBuV/m) = Raw Value(dBuV) + Correction Factor(dB/m)
2. Correction Factor(dB/m) = Antenna Factor(dB/m) + Cable Factor(dB) – Pre-Amplifier Factor(dB)
3. The other emission levels were very low against the limit.
4. Margin value = Emission Level – Limit value
5. " \* ": Fundamental frequency.
6. " # ": The radiated frequency is out of the restricted band.

<b>CHANNEL</b>	TX Channel 149	<b>DETECTOR FUNCTION</b>	Peak (PK)
<b>FREQUENCY RANGE</b>	1GHz ~ 40GHz		Average (AV)

**ANTENNA POLARITY & TEST DISTANCE: HORIZONTAL AT 3 M**

NO.	FREQ. (MHz)	EMISSION LEVEL (dBuV/m)	LIMIT (dBuV/m)	MARGIN (dB)	ANTENNA HEIGHT (m)	TABLE ANGLE (Degree)	RAW VALUE (dBuV)	CORRECTION FACTOR (dB/m)
1	#5640.18	60.6 PK	68.2	-7.6	1.06 H	206	56.6	4.0
2	*5745.00	117.1 PK			1.06 H	206	112.9	4.2
3	*5745.00	106.3 AV			1.06 H	206	102.1	4.2
4	#5957.99	60.9 PK	68.2	-7.3	1.06 H	206	56.4	4.5
5	11490.00	50.3 PK	74.0	-23.7	1.65 H	175	35.1	15.2
6	11490.00	38.8 AV	54.0	-15.2	1.65 H	175	23.6	15.2
7	#17235.00	52.2 PK	74.0	-21.8	1.48 H	174	32.2	20.0
8	#17235.00	39.8 AV	54.0	-14.2	1.48 H	174	19.8	20.0

**ANTENNA POLARITY & TEST DISTANCE: VERTICAL AT 3 M**

NO.	FREQ. (MHz)	EMISSION LEVEL (dBuV/m)	LIMIT (dBuV/m)	MARGIN (dB)	ANTENNA HEIGHT (m)	TABLE ANGLE (Degree)	RAW VALUE (dBuV)	CORRECTION FACTOR (dB/m)
1	#5613.74	59.8 PK	68.2	-8.4	2.27 V	164	55.9	3.9
2	*5745.00	112.2 PK			2.27 V	164	108.0	4.2
3	*5745.00	101.4 AV			2.27 V	164	97.2	4.2
4	#5930.25	60.0 PK	68.2	-8.2	2.27 V	164	55.6	4.4
5	11490.00	50.8 PK	74.0	-23.2	1.66 V	168	35.6	15.2
6	11490.00	39.2 AV	54.0	-14.8	1.66 V	168	24.0	15.2
7	#17235.00	52.5 PK	74.0	-21.5	2.14 V	301	32.5	20.0
8	#17235.00	40.5 AV	54.0	-13.5	2.14 V	301	20.5	20.0

**REMARKS:**

1. Emission Level(dBuV/m) = Raw Value(dBuV) + Correction Factor(dB/m)
2. Correction Factor(dB/m) = Antenna Factor(dB/m) + Cable Factor(dB) – Pre-Amplifier Factor(dB)
3. The other emission levels were very low against the limit.
4. Margin value = Emission Level – Limit value
5. " \* ": Fundamental frequency.
6. " # ": The radiated frequency is out of the restricted band.

<b>CHANNEL</b>	TX Channel 157	<b>DETECTOR FUNCTION</b>	Peak (PK)
<b>FREQUENCY RANGE</b>	1GHz ~ 40GHz		Average (AV)

**ANTENNA POLARITY & TEST DISTANCE: HORIZONTAL AT 3 M**

NO.	FREQ. (MHz)	EMISSION LEVEL (dBuV/m)	LIMIT (dBuV/m)	MARGIN (dB)	ANTENNA HEIGHT (m)	TABLE ANGLE (Degree)	RAW VALUE (dBuV)	CORRECTION FACTOR (dB/m)
1	#5638.11	59.8 PK	68.2	-8.4	1.07 H	213	55.8	4.0
2	*5785.00	116.7 PK			1.07 H	213	112.6	4.1
3	*5785.00	105.9 AV			1.07 H	213	101.8	4.1
4	#5930.93	60.9 PK	68.2	-7.3	1.07 H	213	56.5	4.4
5	11570.00	50.8 PK	74.0	-23.2	1.63 H	168	35.7	15.1
6	11570.00	39.1 AV	54.0	-14.9	1.63 H	168	24.0	15.1
7	#17355.00	51.9 PK	74.0	-22.1	1.46 H	177	31.4	20.5
8	#17355.00	39.6 AV	54.0	-14.4	1.46 H	177	19.1	20.5

**ANTENNA POLARITY & TEST DISTANCE: VERTICAL AT 3 M**

NO.	FREQ. (MHz)	EMISSION LEVEL (dBuV/m)	LIMIT (dBuV/m)	MARGIN (dB)	ANTENNA HEIGHT (m)	TABLE ANGLE (Degree)	RAW VALUE (dBuV)	CORRECTION FACTOR (dB/m)
1	#5613.02	59.7 PK	68.2	-8.5	2.23 V	164	55.8	3.9
2	*5785.00	111.6 PK			2.23 V	164	107.5	4.1
3	*5785.00	100.6 AV			2.23 V	164	96.5	4.1
4	#5948.35	59.6 PK	68.2	-8.6	2.23 V	164	55.2	4.4
5	11570.00	49.9 PK	74.0	-24.1	1.65 V	190	34.8	15.1
6	11570.00	38.5 AV	54.0	-15.5	1.65 V	190	23.4	15.1
7	#17355.00	52.6 PK	74.0	-21.4	2.10 V	288	32.1	20.5
8	#17355.00	40.2 AV	54.0	-13.8	2.10 V	288	19.7	20.5

**REMARKS:**

1. Emission Level(dBuV/m) = Raw Value(dBuV) + Correction Factor(dB/m)
2. Correction Factor(dB/m) = Antenna Factor(dB/m) + Cable Factor(dB) – Pre-Amplifier Factor(dB)
3. The other emission levels were very low against the limit.
4. Margin value = Emission Level – Limit value
5. " \* ": Fundamental frequency.
6. " # ": The radiated frequency is out of the restricted band.

<b>CHANNEL</b>	TX Channel 165	<b>DETECTOR FUNCTION</b>	Peak (PK)
<b>FREQUENCY RANGE</b>	1GHz ~ 40GHz		Average (AV)

**ANTENNA POLARITY & TEST DISTANCE: HORIZONTAL AT 3 M**

NO.	FREQ. (MHz)	EMISSION LEVEL (dBuV/m)	LIMIT (dBuV/m)	MARGIN (dB)	ANTENNA HEIGHT (m)	TABLE ANGLE (Degree)	RAW VALUE (dBuV)	CORRECTION FACTOR (dB/m)
1	#5623.41	60.2 PK	68.2	-8.0	1.09 H	219	56.2	4.0
2	*5825.00	117.0 PK			1.09 H	219	112.8	4.2
3	*5825.00	106.1 AV			1.09 H	219	101.9	4.2
4	#6014.24	61.0 PK	68.2	-7.2	1.09 H	219	56.5	4.5
5	11650.00	50.2 PK	74.0	-23.8	1.69 H	181	35.2	15.0
6	11650.00	38.7 AV	54.0	-15.3	1.69 H	181	23.7	15.0
7	#17475.00	51.9 PK	74.0	-22.1	1.36 H	173	30.8	21.1
8	#17475.00	39.7 AV	54.0	-14.3	1.36 H	173	18.6	21.1

**ANTENNA POLARITY & TEST DISTANCE: VERTICAL AT 3 M**

NO.	FREQ. (MHz)	EMISSION LEVEL (dBuV/m)	LIMIT (dBuV/m)	MARGIN (dB)	ANTENNA HEIGHT (m)	TABLE ANGLE (Degree)	RAW VALUE (dBuV)	CORRECTION FACTOR (dB/m)
1	#5559.44	59.9 PK	68.2	-8.3	2.21 V	149	56.0	3.9
2	*5825.00	111.5 PK			2.21 V	149	107.3	4.2
3	*5825.00	100.4 AV			2.21 V	149	96.2	4.2
4	#5952.59	60.4 PK	68.2	-7.8	2.21 V	149	56.0	4.4
5	11650.00	50.1 PK	74.0	-23.9	1.64 V	184	35.1	15.0
6	11650.00	38.7 AV	54.0	-15.3	1.64 V	184	23.7	15.0
7	#17475.00	53.0 PK	74.0	-21.0	2.14 V	307	31.9	21.1
8	#17475.00	40.8 AV	54.0	-13.2	2.14 V	307	19.7	21.1

**REMARKS:**

1. Emission Level(dBuV/m) = Raw Value(dBuV) + Correction Factor(dB/m)
2. Correction Factor(dB/m) = Antenna Factor(dB/m) + Cable Factor(dB) – Pre-Amplifier Factor(dB)
3. The other emission levels were very low against the limit.
4. Margin value = Emission Level – Limit value
5. " \* ": Fundamental frequency.
6. " # ": The radiated frequency is out of the restricted band.

**802.11ac (VHT20)**

<b>CHANNEL</b>	TX Channel 36	<b>DETECTOR FUNCTION</b>	Peak (PK)
<b>FREQUENCY RANGE</b>	1GHz ~ 40GHz		Average (AV)

**ANTENNA POLARITY & TEST DISTANCE: HORIZONTAL AT 3 M**

NO.	FREQ. (MHz)	EMISSION LEVEL (dBuV/m)	LIMIT (dBuV/m)	MARGIN (dB)	ANTENNA HEIGHT (m)	TABLE ANGLE (Degree)	RAW VALUE (dBuV)	CORRECTION FACTOR (dB/m)
1	5150.00	68.7 PK	74.0	-5.3	1.00 H	201	65.7	3.0
2	5150.00	51.3 AV	54.0	-2.7	1.00 H	201	48.3	3.0
3	*5180.00	115.4 PK			1.00 H	201	112.3	3.1
4	*5180.00	106.1 AV			1.00 H	201	103.0	3.1
5	#10360.00	55.4 PK	74.0	-18.6	1.02 H	190	41.8	13.6
6	#10360.00	41.7 AV	54.0	-12.3	1.02 H	190	28.1	13.6
7	15540.00	52.4 PK	74.0	-21.6	1.46 H	180	36.7	15.7
8	15540.00	40.1 AV	54.0	-13.9	1.46 H	180	24.4	15.7

**ANTENNA POLARITY & TEST DISTANCE: VERTICAL AT 3 M**

NO.	FREQ. (MHz)	EMISSION LEVEL (dBuV/m)	LIMIT (dBuV/m)	MARGIN (dB)	ANTENNA HEIGHT (m)	TABLE ANGLE (Degree)	RAW VALUE (dBuV)	CORRECTION FACTOR (dB/m)
1	5150.00	64.1 PK	74.0	-9.9	2.90 V	308	61.1	3.0
2	5150.00	48.7 AV	54.0	-5.3	2.90 V	308	45.7	3.0
3	*5180.00	112.2 PK			2.90 V	308	109.1	3.1
4	*5180.00	100.9 AV			2.90 V	308	97.8	3.1
5	#10360.00	49.9 PK	74.0	-24.1	1.62 V	187	36.3	13.6
6	#10360.00	38.6 AV	54.0	-15.4	1.62 V	187	25.0	13.6
7	15540.00	52.5 PK	74.0	-21.5	2.19 V	292	36.8	15.7
8	15540.00	40.4 AV	54.0	-13.6	2.19 V	292	24.7	15.7

**REMARKS:**

- Emission Level(dBuV/m) = Raw Value(dBuV) + Correction Factor(dB/m)
- Correction Factor(dB/m) = Antenna Factor(dB/m) + Cable Factor(dB) – Pre-Amplifier Factor(dB)
- The other emission levels were very low against the limit.
- Margin value = Emission Level – Limit value
- " \* ": Fundamental frequency.
- " # ": The radiated frequency is out of the restricted band.

<b>CHANNEL</b>	TX Channel 40	<b>DETECTOR FUNCTION</b>	Peak (PK)
<b>FREQUENCY RANGE</b>	1GHz ~ 40GHz		Average (AV)

**ANTENNA POLARITY & TEST DISTANCE: HORIZONTAL AT 3 M**

NO.	FREQ. (MHz)	EMISSION LEVEL (dBuV/m)	LIMIT (dBuV/m)	MARGIN (dB)	ANTENNA HEIGHT (m)	TABLE ANGLE (Degree)	RAW VALUE (dBuV)	CORRECTION FACTOR (dB/m)
1	*5200.00	115.9 PK			1.00 H	187	112.8	3.1
2	*5200.00	106.3 AV			1.00 H	187	103.2	3.1
3	#10400.00	55.2 PK	74.0	-18.8	1.10 H	206	41.6	13.6
4	#10400.00	41.4 AV	54.0	-12.6	1.10 H	206	27.8	13.6
5	15600.00	51.7 PK	74.0	-22.3	1.49 H	179	36.0	15.7
6	15600.00	39.6 AV	54.0	-14.4	1.49 H	179	23.9	15.7

**ANTENNA POLARITY & TEST DISTANCE: VERTICAL AT 3 M**

NO.	FREQ. (MHz)	EMISSION LEVEL (dBuV/m)	LIMIT (dBuV/m)	MARGIN (dB)	ANTENNA HEIGHT (m)	TABLE ANGLE (Degree)	RAW VALUE (dBuV)	CORRECTION FACTOR (dB/m)
1	*5200.00	112.3 PK			2.89 V	306	109.2	3.1
2	*5200.00	101.4 AV			2.89 V	306	98.3	3.1
3	#10400.00	49.8 PK	74.0	-24.2	1.63 V	175	36.2	13.6
4	#10400.00	38.2 AV	54.0	-15.8	1.63 V	175	24.6	13.6
5	15600.00	53.1 PK	74.0	-20.9	2.18 V	291	37.4	15.7
6	15600.00	40.8 AV	54.0	-13.2	2.18 V	291	25.1	15.7

**REMARKS:**

1. Emission Level(dBuV/m) = Raw Value(dBuV) + Correction Factor(dB/m)
2. Correction Factor(dB/m) = Antenna Factor(dB/m) + Cable Factor(dB) – Pre-Amplifier Factor(dB)
3. The other emission levels were very low against the limit.
4. Margin value = Emission Level – Limit value
5. " \* ": Fundamental frequency.
6. " # ": The radiated frequency is out of the restricted band.

<b>CHANNEL</b>	TX Channel 48	<b>DETECTOR FUNCTION</b>	Peak (PK)
<b>FREQUENCY RANGE</b>	1GHz ~ 40GHz		Average (AV)

**ANTENNA POLARITY & TEST DISTANCE: HORIZONTAL AT 3 M**

NO.	FREQ. (MHz)	EMISSION LEVEL (dBuV/m)	LIMIT (dBuV/m)	MARGIN (dB)	ANTENNA HEIGHT (m)	TABLE ANGLE (Degree)	RAW VALUE (dBuV)	CORRECTION FACTOR (dB/m)
1	*5240.00	115.7 PK			1.03 H	190	112.5	3.2
2	*5240.00	106.1 AV			1.03 H	190	102.9	3.2
3	#10480.00	55.1 PK	74.0	-18.9	1.00 H	213	41.1	14.0
4	#10480.00	41.6 AV	54.0	-12.4	1.00 H	213	27.6	14.0
5	15720.00	51.8 PK	74.0	-22.2	1.41 H	162	36.4	15.4
6	15720.00	39.6 AV	54.0	-14.4	1.41 H	162	24.2	15.4

**ANTENNA POLARITY & TEST DISTANCE: VERTICAL AT 3 M**

NO.	FREQ. (MHz)	EMISSION LEVEL (dBuV/m)	LIMIT (dBuV/m)	MARGIN (dB)	ANTENNA HEIGHT (m)	TABLE ANGLE (Degree)	RAW VALUE (dBuV)	CORRECTION FACTOR (dB/m)
1	*5240.00	111.8 PK			2.89 V	300	108.6	3.2
2	*5240.00	101.0 AV			2.89 V	300	97.8	3.2
3	#10480.00	50.2 PK	74.0	-23.8	1.59 V	188	36.2	14.0
4	#10480.00	38.9 AV	54.0	-15.1	1.59 V	188	24.9	14.0
5	15720.00	53.0 PK	74.0	-21.0	2.12 V	287	37.6	15.4
6	15720.00	40.7 AV	54.0	-13.3	2.12 V	287	25.3	15.4

**REMARKS:**

1. Emission Level(dBuV/m) = Raw Value(dBuV) + Correction Factor(dB/m)
2. Correction Factor(dB/m) = Antenna Factor(dB/m) + Cable Factor(dB) – Pre-Amplifier Factor(dB)
3. The other emission levels were very low against the limit.
4. Margin value = Emission Level – Limit value
5. " \* ": Fundamental frequency.
6. " # ": The radiated frequency is out of the restricted band.



<b>CHANNEL</b>	TX Channel 52	<b>DETECTOR FUNCTION</b>	Peak (PK)
<b>FREQUENCY RANGE</b>	1GHz ~ 40GHz		Average (AV)

**ANTENNA POLARITY & TEST DISTANCE: HORIZONTAL AT 3 M**

NO.	FREQ. (MHz)	EMISSION LEVEL (dBuV/m)	LIMIT (dBuV/m)	MARGIN (dB)	ANTENNA HEIGHT (m)	TABLE ANGLE (Degree)	RAW VALUE (dBuV)	CORRECTION FACTOR (dB/m)
1	*5260.00	116.4 PK			1.02 H	192	113.1	3.3
2	*5260.00	106.8 AV			1.02 H	192	103.5	3.3
3	#10520.00	55.5 PK	74.0	-18.5	1.08 H	199	41.4	14.1
4	#10520.00	42.1 AV	54.0	-11.9	1.08 H	199	28.0	14.1
5	15780.00	51.9 PK	74.0	-22.1	1.41 H	162	36.7	15.2
6	15780.00	39.7 AV	54.0	-14.3	1.41 H	162	24.5	15.2

**ANTENNA POLARITY & TEST DISTANCE: VERTICAL AT 3 M**

NO.	FREQ. (MHz)	EMISSION LEVEL (dBuV/m)	LIMIT (dBuV/m)	MARGIN (dB)	ANTENNA HEIGHT (m)	TABLE ANGLE (Degree)	RAW VALUE (dBuV)	CORRECTION FACTOR (dB/m)
1	*5260.00	112.8 PK			2.81 V	303	109.5	3.3
2	*5260.00	101.5 AV			2.81 V	303	98.2	3.3
3	#10520.00	50.2 PK	74.0	-23.8	1.57 V	160	36.1	14.1
4	#10520.00	39.0 AV	54.0	-15.0	1.57 V	160	24.9	14.1
5	15780.00	53.5 PK	74.0	-20.5	2.19 V	295	38.3	15.2
6	15780.00	41.0 AV	54.0	-13.0	2.19 V	295	25.8	15.2

**REMARKS:**

1. Emission Level(dBuV/m) = Raw Value(dBuV) + Correction Factor(dB/m)
2. Correction Factor(dB/m) = Antenna Factor(dB/m) + Cable Factor(dB) – Pre-Amplifier Factor(dB)
3. The other emission levels were very low against the limit.
4. Margin value = Emission Level – Limit value
5. " \* ": Fundamental frequency.
6. " # ": The radiated frequency is out of the restricted band.

<b>CHANNEL</b>	TX Channel 60	<b>DETECTOR FUNCTION</b>	Peak (PK)
<b>FREQUENCY RANGE</b>	1GHz ~ 40GHz		Average (AV)

**ANTENNA POLARITY & TEST DISTANCE: HORIZONTAL AT 3 M**

NO.	FREQ. (MHz)	EMISSION LEVEL (dBuV/m)	LIMIT (dBuV/m)	MARGIN (dB)	ANTENNA HEIGHT (m)	TABLE ANGLE (Degree)	RAW VALUE (dBuV)	CORRECTION FACTOR (dB/m)
1	*5300.00	116.4 PK			1.00 H	193	113.1	3.3
2	*5300.00	107.2 AV			1.00 H	193	103.9	3.3
3	10600.00	55.1 PK	74.0	-18.9	1.10 H	188	40.8	14.3
4	10600.00	41.4 AV	54.0	-12.6	1.10 H	188	27.1	14.3
5	15900.00	51.8 PK	74.0	-22.2	1.48 H	168	36.7	15.1
6	15900.00	39.9 AV	54.0	-14.1	1.48 H	168	24.8	15.1

**ANTENNA POLARITY & TEST DISTANCE: VERTICAL AT 3 M**

NO.	FREQ. (MHz)	EMISSION LEVEL (dBuV/m)	LIMIT (dBuV/m)	MARGIN (dB)	ANTENNA HEIGHT (m)	TABLE ANGLE (Degree)	RAW VALUE (dBuV)	CORRECTION FACTOR (dB/m)
1	*5300.00	112.2 PK			2.90 V	300	108.9	3.3
2	*5300.00	101.1 AV			2.90 V	300	97.8	3.3
3	10600.00	50.5 PK	74.0	-23.5	1.58 V	180	36.2	14.3
4	10600.00	38.9 AV	54.0	-15.1	1.58 V	180	24.6	14.3
5	15900.00	52.3 PK	74.0	-21.7	2.21 V	308	37.2	15.1
6	15900.00	40.3 AV	54.0	-13.7	2.21 V	308	25.2	15.1

**REMARKS:**

1. Emission Level(dBuV/m) = Raw Value(dBuV) + Correction Factor(dB/m)
2. Correction Factor(dB/m) = Antenna Factor(dB/m) + Cable Factor(dB) – Pre-Amplifier Factor(dB)
3. The other emission levels were very low against the limit.
4. Margin value = Emission Level – Limit value
5. " \* ": Fundamental frequency.

<b>CHANNEL</b>	TX Channel 64	<b>DETECTOR FUNCTION</b>	Peak (PK)
<b>FREQUENCY RANGE</b>	1GHz ~ 40GHz		Average (AV)

**ANTENNA POLARITY & TEST DISTANCE: HORIZONTAL AT 3 M**

NO.	FREQ. (MHz)	EMISSION LEVEL (dBuV/m)	LIMIT (dBuV/m)	MARGIN (dB)	ANTENNA HEIGHT (m)	TABLE ANGLE (Degree)	RAW VALUE (dBuV)	CORRECTION FACTOR (dB/m)
1	*5320.00	117.1 PK			1.00 H	194	113.6	3.5
2	*5320.00	107.5 AV			1.00 H	194	104.0	3.5
3	5350.00	72.4 PK	74.0	-1.6	1.00 H	194	68.9	3.5
4	5350.00	53.4 AV	54.0	-0.6	1.00 H	194	49.9	3.5
5	10640.00	55.3 PK	74.0	-18.7	1.07 H	185	41.0	14.3
6	10640.00	41.6 AV	54.0	-12.4	1.07 H	185	27.3	14.3
7	15960.00	51.5 PK	74.0	-22.5	1.41 H	162	36.4	15.1
8	15960.00	39.3 AV	54.0	-14.7	1.41 H	162	24.2	15.1

**ANTENNA POLARITY & TEST DISTANCE: VERTICAL AT 3 M**

NO.	FREQ. (MHz)	EMISSION LEVEL (dBuV/m)	LIMIT (dBuV/m)	MARGIN (dB)	ANTENNA HEIGHT (m)	TABLE ANGLE (Degree)	RAW VALUE (dBuV)	CORRECTION FACTOR (dB/m)
1	*5320.00	112.5 PK			2.86 V	296	109.0	3.5
2	*5320.00	101.3 AV			2.86 V	296	97.8	3.5
3	5350.00	64.8 PK	74.0	-9.2	2.86 V	296	61.3	3.5
4	5350.00	49.3 AV	54.0	-4.7	2.86 V	296	45.8	3.5
5	10640.00	49.6 PK	74.0	-24.4	1.66 V	179	35.3	14.3
6	10640.00	38.4 AV	54.0	-15.6	1.66 V	179	24.1	14.3
7	15960.00	52.7 PK	74.0	-21.3	2.13 V	291	37.6	15.1
8	15960.00	40.5 AV	54.0	-13.5	2.13 V	291	25.4	15.1

**REMARKS:**

1. Emission Level(dBuV/m) = Raw Value(dBuV) + Correction Factor(dB/m)
2. Correction Factor(dB/m) = Antenna Factor(dB/m) + Cable Factor(dB) – Pre-Amplifier Factor(dB)
3. The other emission levels were very low against the limit.
4. Margin value = Emission Level – Limit value
5. " \* ": Fundamental frequency.

<b>CHANNEL</b>	TX Channel 100	<b>DETECTOR FUNCTION</b>	Peak (PK)
<b>FREQUENCY RANGE</b>	1GHz ~ 40GHz		Average (AV)

**ANTENNA POLARITY & TEST DISTANCE: HORIZONTAL AT 3 M**

NO.	FREQ. (MHz)	EMISSION LEVEL (dBuV/m)	LIMIT (dBuV/m)	MARGIN (dB)	ANTENNA HEIGHT (m)	TABLE ANGLE (Degree)	RAW VALUE (dBuV)	CORRECTION FACTOR (dB/m)
1	#5470.00	71.7 PK	74.0	-2.3	1.00 H	192	68.0	3.7
2	#5470.00	53.7 AV	54.0	-0.3	1.00 H	192	50.0	3.7
3	*5500.00	114.6 PK			1.00 H	192	110.8	3.8
4	*5500.00	104.4 AV			1.00 H	192	100.6	3.8
5	11000.00	53.4 PK	74.0	-20.6	1.07 H	215	38.2	15.2
6	11000.00	39.4 AV	54.0	-14.6	1.07 H	215	24.2	15.2
7	#16500.00	50.8 PK	74.0	-23.2	1.45 H	175	33.4	17.4
8	#16500.00	38.8 AV	54.0	-15.2	1.45 H	175	21.4	17.4

**ANTENNA POLARITY & TEST DISTANCE: VERTICAL AT 3 M**

NO.	FREQ. (MHz)	EMISSION LEVEL (dBuV/m)	LIMIT (dBuV/m)	MARGIN (dB)	ANTENNA HEIGHT (m)	TABLE ANGLE (Degree)	RAW VALUE (dBuV)	CORRECTION FACTOR (dB/m)
1	#5470.00	67.1 PK	74.0	-6.9	2.95 V	193	63.4	3.7
2	#5470.00	51.1 AV	54.0	-2.9	2.95 V	193	47.4	3.7
3	*5500.00	111.6 PK			2.95 V	193	107.8	3.8
4	*5500.00	100.8 AV			2.95 V	193	97.0	3.8
5	11000.00	50.6 PK	74.0	-23.4	1.67 V	171	35.4	15.2
6	11000.00	39.1 AV	54.0	-14.9	1.67 V	171	23.9	15.2
7	#16500.00	53.4 PK	74.0	-20.6	2.21 V	317	36.0	17.4
8	#16500.00	41.1 AV	54.0	-12.9	2.21 V	317	23.7	17.4

**REMARKS:**

1. Emission Level(dBuV/m) = Raw Value(dBuV) + Correction Factor(dB/m)
2. Correction Factor(dB/m) = Antenna Factor(dB/m) + Cable Factor(dB) – Pre-Amplifier Factor(dB)
3. The other emission levels were very low against the limit.
4. Margin value = Emission Level – Limit value
5. " \* ": Fundamental frequency.
6. " # ": The radiated frequency is out of the restricted band.

<b>CHANNEL</b>	TX Channel 116	<b>DETECTOR FUNCTION</b>	Peak (PK)
<b>FREQUENCY RANGE</b>	1GHz ~ 40GHz		Average (AV)

**ANTENNA POLARITY & TEST DISTANCE: HORIZONTAL AT 3 M**

NO.	FREQ. (MHz)	EMISSION LEVEL (dBuV/m)	LIMIT (dBuV/m)	MARGIN (dB)	ANTENNA HEIGHT (m)	TABLE ANGLE (Degree)	RAW VALUE (dBuV)	CORRECTION FACTOR (dB/m)
1	*5580.00	115.2 PK			1.04 H	196	111.3	3.9
2	*5580.00	103.4 AV			1.04 H	196	99.5	3.9
3	11160.00	54.2 PK	74.0	-19.8	1.13 H	177	39.0	15.2
4	11160.00	40.3 AV	54.0	-13.7	1.13 H	177	25.1	15.2
5	#16740.00	51.6 PK	74.0	-22.4	1.43 H	152	33.3	18.3
6	#16740.00	39.2 AV	54.0	-14.8	1.43 H	152	20.9	18.3

**ANTENNA POLARITY & TEST DISTANCE: VERTICAL AT 3 M**

NO.	FREQ. (MHz)	EMISSION LEVEL (dBuV/m)	LIMIT (dBuV/m)	MARGIN (dB)	ANTENNA HEIGHT (m)	TABLE ANGLE (Degree)	RAW VALUE (dBuV)	CORRECTION FACTOR (dB/m)
1	*5580.00	112.2 PK			2.86 V	185	108.3	3.9
2	*5580.00	100.8 AV			2.86 V	185	96.9	3.9
3	11160.00	50.1 PK	74.0	-23.9	1.64 V	173	34.9	15.2
4	11160.00	38.5 AV	54.0	-15.5	1.64 V	173	23.3	15.2
5	#16740.00	52.7 PK	74.0	-21.3	2.16 V	296	34.4	18.3
6	#16740.00	40.6 AV	54.0	-13.4	2.16 V	296	22.3	18.3

**REMARKS:**

1. Emission Level(dBuV/m) = Raw Value(dBuV) + Correction Factor(dB/m)
2. Correction Factor(dB/m) = Antenna Factor(dB/m) + Cable Factor(dB) – Pre-Amplifier Factor(dB)
3. The other emission levels were very low against the limit.
4. Margin value = Emission Level – Limit value
5. " \* ": Fundamental frequency.
6. " # ": The radiated frequency is out of the restricted band.

<b>CHANNEL</b>	TX Channel 140	<b>DETECTOR FUNCTION</b>	Peak (PK)
<b>FREQUENCY RANGE</b>	1GHz ~ 40GHz		Average (AV)

**ANTENNA POLARITY & TEST DISTANCE: HORIZONTAL AT 3 M**

NO.	FREQ. (MHz)	EMISSION LEVEL (dBuV/m)	LIMIT (dBuV/m)	MARGIN (dB)	ANTENNA HEIGHT (m)	TABLE ANGLE (Degree)	RAW VALUE (dBuV)	CORRECTION FACTOR (dB/m)
1	*5700.00	113.7 PK			1.06 H	203	109.5	4.2
2	*5700.00	103.3 AV			1.06 H	203	99.1	4.2
3	#5725.00	71.5 PK	74.0	-2.5	1.06 H	203	67.3	4.2
4	#5725.00	52.7 AV	54.0	-1.3	1.06 H	203	48.5	4.2
5	11400.00	50.1 PK	74.0	-23.9	1.56 H	149	34.6	15.5
6	11400.00	38.4 AV	54.0	-15.6	1.56 H	149	22.9	15.5
7	#17100.00	56.1 PK	74.0	-17.9	2.19 H	317	36.0	20.1
8	#17100.00	43.3 AV	54.0	-10.7	2.19 H	317	23.2	20.1

**ANTENNA POLARITY & TEST DISTANCE: VERTICAL AT 3 M**

NO.	FREQ. (MHz)	EMISSION LEVEL (dBuV/m)	LIMIT (dBuV/m)	MARGIN (dB)	ANTENNA HEIGHT (m)	TABLE ANGLE (Degree)	RAW VALUE (dBuV)	CORRECTION FACTOR (dB/m)
1	*5700.00	112.0 PK			2.95 V	192	107.8	4.2
2	*5700.00	100.6 AV			2.95 V	192	96.4	4.2
3	#5725.00	67.1 PK	74.0	-6.9	2.95 V	192	62.9	4.2
4	#5725.00	49.7 AV	54.0	-4.3	2.95 V	192	45.5	4.2
5	11400.00	50.5 PK	74.0	-23.5	1.65 V	187	35.0	15.5
6	11400.00	39.1 AV	54.0	-14.9	1.65 V	187	23.6	15.5
7	#17100.00	53.1 PK	74.0	-20.9	2.14 V	309	33.0	20.1
8	#17100.00	40.8 AV	54.0	-13.2	2.14 V	309	20.7	20.1

**REMARKS:**

1. Emission Level(dBuV/m) = Raw Value(dBuV) + Correction Factor(dB/m)
2. Correction Factor(dB/m) = Antenna Factor(dB/m) + Cable Factor(dB) – Pre-Amplifier Factor(dB)
3. The other emission levels were very low against the limit.
4. Margin value = Emission Level – Limit value
5. " \* ": Fundamental frequency.
6. " # ": The radiated frequency is out of the restricted band.

<b>CHANNEL</b>	TX Channel 144	<b>DETECTOR FUNCTION</b>	Peak (PK)
<b>FREQUENCY RANGE</b>	1GHz ~ 40GHz		Average (AV)

**ANTENNA POLARITY & TEST DISTANCE: HORIZONTAL AT 3 M**

NO.	FREQ. (MHz)	EMISSION LEVEL (dBUV/m)	LIMIT (dBUV/m)	MARGIN (dB)	ANTENNA HEIGHT (m)	TABLE ANGLE (Degree)	RAW VALUE (dBUV)	CORRECTION FACTOR (dB/m)
1	*5720.00	113.8 PK			1.00 H	196	109.6	4.2
2	*5720.00	104.1 AV			1.00 H	196	99.9	4.2
3	#5850.00	56.6 PK	74.0	-17.4	1.00 H	196	52.4	4.2
4	#5850.00	44.4 AV	54.0	-9.6	1.00 H	196	40.2	4.2
5	11440.00	50.2 PK	74.0	-23.8	1.60 H	159	34.9	15.3
6	11440.00	38.6 AV	54.0	-15.4	1.60 H	159	23.3	15.3
7	#17160.00	52.2 PK	74.0	-21.8	1.46 H	187	32.4	19.8
8	#17160.00	39.6 AV	54.0	-14.4	1.46 H	187	19.8	19.8

**ANTENNA POLARITY & TEST DISTANCE: VERTICAL AT 3 M**

NO.	FREQ. (MHz)	EMISSION LEVEL (dBUV/m)	LIMIT (dBUV/m)	MARGIN (dB)	ANTENNA HEIGHT (m)	TABLE ANGLE (Degree)	RAW VALUE (dBUV)	CORRECTION FACTOR (dB/m)
1	*5720.00	112.4 PK			2.85 V	195	108.2	4.2
2	*5720.00	101.1 AV			2.85 V	195	96.9	4.2
3	#5850.00	67.2 PK	74.0	-6.8	2.85 V	195	63.0	4.2
4	#5850.00	41.2 AV	54.0	-12.8	2.85 V	195	37.0	4.2
5	11440.00	50.3 PK	74.0	-23.7	1.68 V	191	35.0	15.3
6	11440.00	38.8 AV	54.0	-15.2	1.68 V	191	23.5	15.3
7	#17160.00	52.8 PK	74.0	-21.2	2.11 V	312	33.0	19.8
8	#17160.00	40.4 AV	54.0	-13.6	2.11 V	312	20.6	19.8

**REMARKS:**

1. Emission Level(dBUV/m) = Raw Value(dBUV) + Correction Factor(dB/m)
2. Correction Factor(dB/m) = Antenna Factor(dB/m) + Cable Factor(dB) – Pre-Amplifier Factor(dB)
3. The other emission levels were very low against the limit.
4. Margin value = Emission Level – Limit value
5. " \* ": Fundamental frequency.
6. " # ": The radiated frequency is out of the restricted band.

<b>CHANNEL</b>	TX Channel 149	<b>DETECTOR FUNCTION</b>	Peak (PK)
<b>FREQUENCY RANGE</b>	1GHz ~ 40GHz		Average (AV)

**ANTENNA POLARITY & TEST DISTANCE: HORIZONTAL AT 3 M**

NO.	FREQ. (MHz)	EMISSION LEVEL (dBuV/m)	LIMIT (dBuV/m)	MARGIN (dB)	ANTENNA HEIGHT (m)	TABLE ANGLE (Degree)	RAW VALUE (dBuV)	CORRECTION FACTOR (dB/m)
1	#5583.82	60.8 PK	68.2	-7.4	1.06 H	205	56.9	3.9
2	*5745.00	117.6 PK			1.06 H	205	113.4	4.2
3	*5745.00	107.6 AV			1.06 H	205	103.4	4.2
4	#5949.94	60.7 PK	68.2	-7.5	1.06 H	205	56.3	4.4
5	11490.00	49.9 PK	74.0	-24.1	1.67 H	185	34.7	15.2
6	11490.00	38.7 AV	54.0	-15.3	1.67 H	185	23.5	15.2
7	#17235.00	52.3 PK	74.0	-21.7	1.41 H	189	32.3	20.0
8	#17235.00	40.0 AV	54.0	-14.0	1.41 H	189	20.0	20.0

**ANTENNA POLARITY & TEST DISTANCE: VERTICAL AT 3 M**

NO.	FREQ. (MHz)	EMISSION LEVEL (dBuV/m)	LIMIT (dBuV/m)	MARGIN (dB)	ANTENNA HEIGHT (m)	TABLE ANGLE (Degree)	RAW VALUE (dBuV)	CORRECTION FACTOR (dB/m)
1	#5628.76	59.1 PK	68.2	-9.1	2.65 V	154	55.1	4.0
2	*5745.00	111.7 PK			2.65 V	154	107.5	4.2
3	*5745.00	101.8 AV			2.65 V	154	97.6	4.2
4	#5951.64	59.7 PK	68.2	-8.5	2.65 V	154	55.3	4.4
5	11490.00	50.5 PK	74.0	-23.5	1.60 V	175	35.3	15.2
6	11490.00	39.1 AV	54.0	-14.9	1.60 V	175	23.9	15.2
7	#17235.00	52.6 PK	74.0	-21.4	2.15 V	289	32.6	20.0
8	#17235.00	40.4 AV	54.0	-13.6	2.15 V	289	20.4	20.0

**REMARKS:**

1. Emission Level(dBuV/m) = Raw Value(dBuV) + Correction Factor(dB/m)
2. Correction Factor(dB/m) = Antenna Factor(dB/m) + Cable Factor(dB) – Pre-Amplifier Factor(dB)
3. The other emission levels were very low against the limit.
4. Margin value = Emission Level – Limit value
5. " \* ": Fundamental frequency.
6. " # ": The radiated frequency is out of the restricted band.



<b>CHANNEL</b>	TX Channel 157	<b>DETECTOR FUNCTION</b>	Peak (PK)
<b>FREQUENCY RANGE</b>	1GHz ~ 40GHz		Average (AV)

**ANTENNA POLARITY & TEST DISTANCE: HORIZONTAL AT 3 M**

NO.	FREQ. (MHz)	EMISSION LEVEL (dBuV/m)	LIMIT (dBuV/m)	MARGIN (dB)	ANTENNA HEIGHT (m)	TABLE ANGLE (Degree)	RAW VALUE (dBuV)	CORRECTION FACTOR (dB/m)
1	#5597.93	60.4 PK	68.2	-7.8	1.02 H	197	56.5	3.9
2	*5785.00	116.9 PK			1.02 H	197	112.8	4.1
3	*5785.00	106.9 AV			1.02 H	197	102.8	4.1
4	#5969.69	60.9 PK	68.2	-7.3	1.02 H	197	56.4	4.5
5	11570.00	50.7 PK	74.0	-23.3	1.64 H	184	35.6	15.1
6	11570.00	39.2 AV	54.0	-14.8	1.64 H	184	24.1	15.1
7	#17355.00	51.7 PK	74.0	-22.3	1.42 H	188	31.2	20.5
8	#17355.00	39.6 AV	54.0	-14.4	1.42 H	188	19.1	20.5

**ANTENNA POLARITY & TEST DISTANCE: VERTICAL AT 3 M**

NO.	FREQ. (MHz)	EMISSION LEVEL (dBuV/m)	LIMIT (dBuV/m)	MARGIN (dB)	ANTENNA HEIGHT (m)	TABLE ANGLE (Degree)	RAW VALUE (dBuV)	CORRECTION FACTOR (dB/m)
1	#5589.52	59.7 PK	68.2	-8.5	2.69 V	155	55.8	3.9
2	*5785.00	110.8 PK			2.69 V	156	106.7	4.1
3	*5785.00	101.0 AV			2.69 V	156	96.9	4.1
4	#5931.85	60.0 PK	68.2	-8.2	2.69 V	155	55.6	4.4
5	11570.00	49.7 PK	74.0	-24.3	1.66 V	180	34.6	15.1
6	11570.00	38.3 AV	54.0	-15.7	1.66 V	180	23.2	15.1
7	#17355.00	52.8 PK	74.0	-21.2	2.20 V	293	32.3	20.5
8	#17355.00	40.6 AV	54.0	-13.4	2.20 V	293	20.1	20.5

**REMARKS:**

1. Emission Level(dBuV/m) = Raw Value(dBuV) + Correction Factor(dB/m)
2. Correction Factor(dB/m) = Antenna Factor(dB/m) + Cable Factor(dB) – Pre-Amplifier Factor(dB)
3. The other emission levels were very low against the limit.
4. Margin value = Emission Level – Limit value
5. " \* ": Fundamental frequency.
6. " # ": The radiated frequency is out of the restricted band.

<b>CHANNEL</b>	TX Channel 165	<b>DETECTOR FUNCTION</b>	Peak (PK)
<b>FREQUENCY RANGE</b>	1GHz ~ 40GHz		Average (AV)

**ANTENNA POLARITY & TEST DISTANCE: HORIZONTAL AT 3 M**

NO.	FREQ. (MHz)	EMISSION LEVEL (dBuV/m)	LIMIT (dBuV/m)	MARGIN (dB)	ANTENNA HEIGHT (m)	TABLE ANGLE (Degree)	RAW VALUE (dBuV)	CORRECTION FACTOR (dB/m)
1	#5648.62	60.1 PK	68.2	-8.1	1.11 H	189	56.1	4.0
2	*5825.00	117.5 PK			1.11 H	189	113.3	4.2
3	*5825.00	107.3 AV			1.11 H	189	103.1	4.2
4	#5932.62	60.5 PK	68.2	-7.7	1.11 H	189	56.1	4.4
5	11650.00	49.9 PK	74.0	-24.1	1.62 H	178	34.9	15.0
6	11650.00	38.4 AV	54.0	-15.6	1.62 H	178	23.4	15.0
7	#17475.00	51.8 PK	74.0	-22.2	1.44 H	192	30.7	21.1
8	#17475.00	39.6 AV	54.0	-14.4	1.44 H	192	18.5	21.1

**ANTENNA POLARITY & TEST DISTANCE: VERTICAL AT 3 M**

NO.	FREQ. (MHz)	EMISSION LEVEL (dBuV/m)	LIMIT (dBuV/m)	MARGIN (dB)	ANTENNA HEIGHT (m)	TABLE ANGLE (Degree)	RAW VALUE (dBuV)	CORRECTION FACTOR (dB/m)
1	#5582.12	59.5 PK	68.2	-8.7	2.66 V	149	55.6	3.9
2	*5825.00	111.3 PK			2.66 V	149	107.1	4.2
3	*5825.00	101.4 AV			2.66 V	149	97.2	4.2
4	#5930.43	59.9 PK	68.2	-8.3	2.66 V	149	55.5	4.4
5	11650.00	49.8 PK	74.0	-24.2	1.59 V	165	34.8	15.0
6	11650.00	38.3 AV	54.0	-15.7	1.59 V	165	23.3	15.0
7	#17475.00	53.0 PK	74.0	-21.0	2.15 V	285	31.9	21.1
8	#17475.00	40.6 AV	54.0	-13.4	2.15 V	285	19.5	21.1

**REMARKS:**

1. Emission Level(dBuV/m) = Raw Value(dBuV) + Correction Factor(dB/m)
2. Correction Factor(dB/m) = Antenna Factor(dB/m) + Cable Factor(dB) – Pre-Amplifier Factor(dB)
3. The other emission levels were very low against the limit.
4. Margin value = Emission Level – Limit value
5. " \* ": Fundamental frequency.
6. " # ": The radiated frequency is out of the restricted band.

802.11ac (VHT40)

<b>CHANNEL</b>	TX Channel 38	<b>DETECTOR FUNCTION</b>	Peak (PK)
<b>FREQUENCY RANGE</b>	1GHz ~ 40GHz		Average (AV)

ANTENNA POLARITY & TEST DISTANCE: HORIZONTAL AT 3 M								
NO.	FREQ. (MHz)	EMISSION LEVEL (dBuV/m)	LIMIT (dBuV/m)	MARGIN (dB)	ANTENNA HEIGHT (m)	TABLE ANGLE (Degree)	RAW VALUE (dBuV)	CORRECTION FACTOR (dB/m)
1	5150.00	72.7 PK	74.0	-1.3	1.19 H	201	69.7	3.0
2	5150.00	53.4 AV	54.0	-0.6	1.19 H	201	50.4	3.0
3	*5190.00	109.5 PK			1.19 H	201	106.4	3.1
4	*5190.00	100.1 AV			1.19 H	201	97.0	3.1
5	#10380.00	53.4 PK	74.0	-20.6	1.00 H	218	39.7	13.7
6	#10380.00	39.6 AV	54.0	-14.4	1.00 H	218	25.9	13.7
7	15570.00	51.6 PK	74.0	-22.4	1.51 H	150	36.0	15.6
8	15570.00	39.4 AV	54.0	-14.6	1.51 H	150	23.8	15.6

ANTENNA POLARITY & TEST DISTANCE: VERTICAL AT 3 M								
NO.	FREQ. (MHz)	EMISSION LEVEL (dBuV/m)	LIMIT (dBuV/m)	MARGIN (dB)	ANTENNA HEIGHT (m)	TABLE ANGLE (Degree)	RAW VALUE (dBuV)	CORRECTION FACTOR (dB/m)
1	5150.00	64.3 PK	74.0	-9.7	2.60 V	174	61.3	3.0
2	5150.00	48.6 AV	54.0	-5.4	2.60 V	174	45.6	3.0
3	*5190.00	103.6 PK			2.60 V	174	100.5	3.1
4	*5190.00	94.3 AV			2.60 V	174	91.2	3.1
5	#10380.00	50.7 PK	74.0	-23.3	1.63 V	169	37.0	13.7
6	#10380.00	39.1 AV	54.0	-14.9	1.63 V	169	25.4	13.7
7	15570.00	53.1 PK	74.0	-20.9	2.10 V	311	37.5	15.6
8	15570.00	40.6 AV	54.0	-13.4	2.10 V	311	25.0	15.6

**REMARKS:**

1. Emission Level(dBuV/m) = Raw Value(dBuV) + Correction Factor(dB/m)
2. Correction Factor(dB/m) = Antenna Factor(dB/m) + Cable Factor(dB) – Pre-Amplifier Factor(dB)
3. The other emission levels were very low against the limit.
4. Margin value = Emission Level – Limit value
5. " \* ": Fundamental frequency.
6. " # ": The radiated frequency is out of the restricted band.

<b>CHANNEL</b>	TX Channel 46	<b>DETECTOR FUNCTION</b>	Peak (PK)
<b>FREQUENCY RANGE</b>	1GHz ~ 40GHz		Average (AV)

**ANTENNA POLARITY & TEST DISTANCE: HORIZONTAL AT 3 M**

NO.	FREQ. (MHz)	EMISSION LEVEL (dBuV/m)	LIMIT (dBuV/m)	MARGIN (dB)	ANTENNA HEIGHT (m)	TABLE ANGLE (Degree)	RAW VALUE (dBuV)	CORRECTION FACTOR (dB/m)
1	*5230.00	112.5 PK			1.17 H	199	109.3	3.2
2	*5230.00	103.0 AV			1.17 H	199	99.8	3.2
3	#10460.00	53.5 PK	74.0	-20.5	1.04 H	208	39.6	13.9
4	#10460.00	39.6 AV	54.0	-14.4	1.04 H	208	25.7	13.9
5	15690.00	51.3 PK	74.0	-22.7	1.51 H	178	35.7	15.6
6	15690.00	39.1 AV	54.0	-14.9	1.51 H	178	23.5	15.6

**ANTENNA POLARITY & TEST DISTANCE: VERTICAL AT 3 M**

NO.	FREQ. (MHz)	EMISSION LEVEL (dBuV/m)	LIMIT (dBuV/m)	MARGIN (dB)	ANTENNA HEIGHT (m)	TABLE ANGLE (Degree)	RAW VALUE (dBuV)	CORRECTION FACTOR (dB/m)
1	*5230.00	106.9 PK			2.61 V	170	103.7	3.2
2	*5230.00	97.5 AV			2.61 V	170	94.3	3.2
3	#10460.00	49.7 PK	74.0	-24.3	1.65 V	173	35.8	13.9
4	#10460.00	38.3 AV	54.0	-15.7	1.65 V	173	24.4	13.9
5	15690.00	52.8 PK	74.0	-21.2	2.16 V	309	37.2	15.6
6	15690.00	40.4 AV	54.0	-13.6	2.16 V	309	24.8	15.6

**REMARKS:**

1. Emission Level(dBuV/m) = Raw Value(dBuV) + Correction Factor(dB/m)
2. Correction Factor(dB/m) = Antenna Factor(dB/m) + Cable Factor(dB) – Pre-Amplifier Factor(dB)
3. The other emission levels were very low against the limit.
4. Margin value = Emission Level – Limit value
5. " \* ": Fundamental frequency.
6. " # ": The radiated frequency is out of the restricted band.

<b>CHANNEL</b>	TX Channel 54	<b>DETECTOR FUNCTION</b>	Peak (PK)
<b>FREQUENCY RANGE</b>	1GHz ~ 40GHz		Average (AV)

**ANTENNA POLARITY & TEST DISTANCE: HORIZONTAL AT 3 M**

NO.	FREQ. (MHz)	EMISSION LEVEL (dBuV/m)	LIMIT (dBuV/m)	MARGIN (dB)	ANTENNA HEIGHT (m)	TABLE ANGLE (Degree)	RAW VALUE (dBuV)	CORRECTION FACTOR (dB/m)
1	*5270.00	112.5 PK			1.14 H	209	109.2	3.3
2	*5270.00	103.1 AV			1.14 H	209	99.8	3.3
3	#10540.00	53.1 PK	74.0	-20.9	1.00 H	190	38.9	14.2
4	#10540.00	39.6 AV	54.0	-14.4	1.00 H	190	25.4	14.2
5	15810.00	50.8 PK	74.0	-23.2	1.53 H	171	35.8	15.0
6	15810.00	38.8 AV	54.0	-15.2	1.53 H	171	23.8	15.0

**ANTENNA POLARITY & TEST DISTANCE: VERTICAL AT 3 M**

NO.	FREQ. (MHz)	EMISSION LEVEL (dBuV/m)	LIMIT (dBuV/m)	MARGIN (dB)	ANTENNA HEIGHT (m)	TABLE ANGLE (Degree)	RAW VALUE (dBuV)	CORRECTION FACTOR (dB/m)
1	*5270.00	106.9 PK			2.57 V	162	103.6	3.3
2	*5270.00	97.3 AV			2.57 V	162	94.0	3.3
3	#10540.00	50.3 PK	74.0	-23.7	1.62 V	186	36.1	14.2
4	#10540.00	39.0 AV	54.0	-15.0	1.62 V	186	24.8	14.2
5	15810.00	53.0 PK	74.0	-21.0	2.12 V	313	38.0	15.0
6	15810.00	40.7 AV	54.0	-13.3	2.12 V	313	25.7	15.0

**REMARKS:**

1. Emission Level(dBuV/m) = Raw Value(dBuV) + Correction Factor(dB/m)
2. Correction Factor(dB/m) = Antenna Factor(dB/m) + Cable Factor(dB) – Pre-Amplifier Factor(dB)
3. The other emission levels were very low against the limit.
4. Margin value = Emission Level – Limit value
5. " \* ": Fundamental frequency.
6. " # ": The radiated frequency is out of the restricted band.

<b>CHANNEL</b>	TX Channel 62	<b>DETECTOR FUNCTION</b>	Peak (PK)
<b>FREQUENCY RANGE</b>	1GHz ~ 40GHz		Average (AV)

**ANTENNA POLARITY & TEST DISTANCE: HORIZONTAL AT 3 M**

NO.	FREQ. (MHz)	EMISSION LEVEL (dBuV/m)	LIMIT (dBuV/m)	MARGIN (dB)	ANTENNA HEIGHT (m)	TABLE ANGLE (Degree)	RAW VALUE (dBuV)	CORRECTION FACTOR (dB/m)
1	*5310.00	110.1 PK			1.01 H	199	106.7	3.4
2	*5310.00	100.7 AV			1.01 H	199	97.3	3.4
3	5350.00	71.3 PK	74.0	-2.7	1.01 H	199	67.8	3.5
4	5350.00	53.6 AV	54.0	-0.4	1.01 H	199	50.1	3.5
5	10620.00	53.0 PK	74.0	-21.0	1.02 H	191	38.7	14.3
6	10620.00	39.2 AV	54.0	-14.8	1.02 H	191	24.9	14.3
7	15930.00	51.8 PK	74.0	-22.2	1.50 H	165	36.7	15.1
8	15930.00	39.7 AV	54.0	-14.3	1.50 H	165	24.6	15.1

**ANTENNA POLARITY & TEST DISTANCE: VERTICAL AT 3 M**

NO.	FREQ. (MHz)	EMISSION LEVEL (dBuV/m)	LIMIT (dBuV/m)	MARGIN (dB)	ANTENNA HEIGHT (m)	TABLE ANGLE (Degree)	RAW VALUE (dBuV)	CORRECTION FACTOR (dB/m)
1	*5310.00	103.7 PK			2.62 V	168	100.3	3.4
2	*5310.00	94.1 AV			2.62 V	168	90.7	3.4
3	5350.00	65.0 PK	74.0	-9.0	2.62 V	168	61.5	3.5
4	5350.00	49.0 AV	54.0	-5.0	2.62 V	168	45.5	3.5
5	10620.00	50.1 PK	74.0	-23.9	1.62 V	161	35.8	14.3
6	10620.00	38.8 AV	54.0	-15.2	1.62 V	161	24.5	14.3
7	15930.00	52.7 PK	74.0	-21.3	2.14 V	298	37.6	15.1
8	15930.00	40.6 AV	54.0	-13.4	2.14 V	298	25.5	15.1

**REMARKS:**

1. Emission Level(dBuV/m) = Raw Value(dBuV) + Correction Factor(dB/m)
2. Correction Factor(dB/m) = Antenna Factor(dB/m) + Cable Factor(dB) – Pre-Amplifier Factor(dB)
3. The other emission levels were very low against the limit.
4. Margin value = Emission Level – Limit value
5. " \* ": Fundamental frequency.

<b>CHANNEL</b>	TX Channel 102	<b>DETECTOR FUNCTION</b>	Peak (PK)
<b>FREQUENCY RANGE</b>	1GHz ~ 40GHz		Average (AV)

**ANTENNA POLARITY & TEST DISTANCE: HORIZONTAL AT 3 M**

NO.	FREQ. (MHz)	EMISSION LEVEL (dBuV/m)	LIMIT (dBuV/m)	MARGIN (dB)	ANTENNA HEIGHT (m)	TABLE ANGLE (Degree)	RAW VALUE (dBuV)	CORRECTION FACTOR (dB/m)
1	#5470.00	71.6 PK	74.0	-2.4	1.06 H	196	67.9	3.7
2	#5470.00	53.8 AV	54.0	-0.2	1.06 H	196	50.1	3.7
3	*5510.00	108.2 PK			1.06 H	196	104.4	3.8
4	*5510.00	98.3 AV			1.06 H	196	94.5	3.8
5	11020.00	52.7 PK	74.0	-21.3	1.00 H	208	37.6	15.1
6	11020.00	38.9 AV	54.0	-15.1	1.00 H	208	23.8	15.1
7	#16530.00	51.3 PK	74.0	-22.7	1.49 H	177	33.8	17.5
8	#16530.00	39.0 AV	54.0	-15.0	1.49 H	177	21.5	17.5

**ANTENNA POLARITY & TEST DISTANCE: VERTICAL AT 3 M**

NO.	FREQ. (MHz)	EMISSION LEVEL (dBuV/m)	LIMIT (dBuV/m)	MARGIN (dB)	ANTENNA HEIGHT (m)	TABLE ANGLE (Degree)	RAW VALUE (dBuV)	CORRECTION FACTOR (dB/m)
1	#5470.00	68.1 PK	74.0	-5.9	2.60 V	176	64.4	3.7
2	#5470.00	49.0 AV	54.0	-5.0	2.60 V	176	45.3	3.7
3	*5510.00	105.3 PK			2.60 V	176	101.5	3.8
4	*5510.00	95.8 AV			2.60 V	176	92.0	3.8
5	11020.00	50.5 PK	74.0	-23.5	1.66 V	180	35.4	15.1
6	11020.00	39.0 AV	54.0	-15.0	1.66 V	180	23.9	15.1
7	#16530.00	52.9 PK	74.0	-21.1	2.17 V	302	35.4	17.5
8	#16530.00	40.3 AV	54.0	-13.7	2.17 V	302	22.8	17.5

**REMARKS:**

1. Emission Level(dBuV/m) = Raw Value(dBuV) + Correction Factor(dB/m)
2. Correction Factor(dB/m) = Antenna Factor(dB/m) + Cable Factor(dB) – Pre-Amplifier Factor(dB)
3. The other emission levels were very low against the limit.
4. Margin value = Emission Level – Limit value
5. " \* ": Fundamental frequency.
6. " # ": The radiated frequency is out of the restricted band.

<b>CHANNEL</b>	TX Channel 110	<b>DETECTOR FUNCTION</b>	Peak (PK)
<b>FREQUENCY RANGE</b>	1GHz ~ 40GHz		Average (AV)

**ANTENNA POLARITY & TEST DISTANCE: HORIZONTAL AT 3 M**

NO.	FREQ. (MHz)	EMISSION LEVEL (dBuV/m)	LIMIT (dBuV/m)	MARGIN (dB)	ANTENNA HEIGHT (m)	TABLE ANGLE (Degree)	RAW VALUE (dBuV)	CORRECTION FACTOR (dB/m)
1	*5550.00	112.1 PK			1.00 H	198	108.2	3.9
2	*5550.00	102.2 AV			1.00 H	198	98.3	3.9
3	11100.00	52.7 PK	74.0	-21.3	1.00 H	200	37.6	15.1
4	11100.00	39.1 AV	54.0	-14.9	1.00 H	200	24.0	15.1
5	#16650.00	51.1 PK	74.0	-22.9	1.53 H	177	33.1	18.0
6	#16650.00	38.9 AV	54.0	-15.1	1.53 H	177	20.9	18.0

**ANTENNA POLARITY & TEST DISTANCE: VERTICAL AT 3 M**

NO.	FREQ. (MHz)	EMISSION LEVEL (dBuV/m)	LIMIT (dBuV/m)	MARGIN (dB)	ANTENNA HEIGHT (m)	TABLE ANGLE (Degree)	RAW VALUE (dBuV)	CORRECTION FACTOR (dB/m)
1	*5550.00	109.1 PK			2.63 V	181	105.2	3.9
2	*5550.00	99.6 AV			2.63 V	181	95.7	3.9
3	11100.00	50.7 PK	74.0	-23.3	1.56 V	180	35.6	15.1
4	11100.00	39.2 AV	54.0	-14.8	1.56 V	180	24.1	15.1
5	#16650.00	53.0 PK	74.0	-21.0	2.12 V	288	35.0	18.0
6	#16650.00	40.9 AV	54.0	-13.1	2.12 V	288	22.9	18.0

**REMARKS:**

1. Emission Level(dBuV/m) = Raw Value(dBuV) + Correction Factor(dB/m)
2. Correction Factor(dB/m) = Antenna Factor(dB/m) + Cable Factor(dB) – Pre-Amplifier Factor(dB)
3. The other emission levels were very low against the limit.
4. Margin value = Emission Level – Limit value
5. " \* ": Fundamental frequency.
6. " # ": The radiated frequency is out of the restricted band.



<b>CHANNEL</b>	TX Channel 134	<b>DETECTOR FUNCTION</b>	Peak (PK)
<b>FREQUENCY RANGE</b>	1GHz ~ 40GHz		Average (AV)

**ANTENNA POLARITY & TEST DISTANCE: HORIZONTAL AT 3 M**

NO.	FREQ. (MHz)	EMISSION LEVEL (dBuV/m)	LIMIT (dBuV/m)	MARGIN (dB)	ANTENNA HEIGHT (m)	TABLE ANGLE (Degree)	RAW VALUE (dBuV)	CORRECTION FACTOR (dB/m)
1	*5670.00	111.0 PK			1.01 H	203	107.0	4.0
2	*5670.00	101.6 AV			1.01 H	203	97.6	4.0
3	#5725.00	69.2 PK	74.0	-4.8	1.01 H	203	65.0	4.2
4	<b>#5725.00</b>	<b>53.9 AV</b>	<b>54.0</b>	<b>-0.1</b>	<b>1.01 H</b>	<b>203</b>	<b>49.7</b>	<b>4.2</b>
5	11340.00	49.9 PK	74.0	-24.1	1.71 H	195	34.6	15.3
6	11340.00	38.4 AV	54.0	-15.6	1.71 H	195	23.1	15.3
7	#17010.00	52.3 PK	74.0	-21.7	1.38 H	170	32.4	19.9
8	#17010.00	39.6 AV	54.0	-14.4	1.38 H	170	19.7	19.9

**ANTENNA POLARITY & TEST DISTANCE: VERTICAL AT 3 M**

NO.	FREQ. (MHz)	EMISSION LEVEL (dBuV/m)	LIMIT (dBuV/m)	MARGIN (dB)	ANTENNA HEIGHT (m)	TABLE ANGLE (Degree)	RAW VALUE (dBuV)	CORRECTION FACTOR (dB/m)
1	*5670.00	109.2 PK			2.58 V	196	105.2	4.0
2	*5670.00	99.8 AV			2.58 V	196	95.8	4.0
3	#5725.00	67.5 PK	74.0	-6.5	2.58 V	196	63.3	4.2
4	#5725.00	51.2 AV	54.0	-2.8	2.58 V	196	47.0	4.2
5	11340.00	50.0 PK	74.0	-24.0	1.63 V	160	34.7	15.3
6	11340.00	38.5 AV	54.0	-15.5	1.63 V	160	23.2	15.3
7	#17010.00	53.6 PK	74.0	-20.4	2.10 V	298	33.7	19.9
8	#17010.00	41.0 AV	54.0	-13.0	2.10 V	298	21.1	19.9

**REMARKS:**

1. Emission Level(dBuV/m) = Raw Value(dBuV) + Correction Factor(dB/m)
2. Correction Factor(dB/m) = Antenna Factor(dB/m) + Cable Factor(dB) – Pre-Amplifier Factor(dB)
3. The other emission levels were very low against the limit.
4. Margin value = Emission Level – Limit value
5. " \* ": Fundamental frequency.
6. " # ": The radiated frequency is out of the restricted band.

<b>CHANNEL</b>	TX Channel 142	<b>DETECTOR FUNCTION</b>	Peak (PK)
<b>FREQUENCY RANGE</b>	1GHz ~ 40GHz		Average (AV)

**ANTENNA POLARITY & TEST DISTANCE: HORIZONTAL AT 3 M**

NO.	FREQ. (MHz)	EMISSION LEVEL (dBuV/m)	LIMIT (dBuV/m)	MARGIN (dB)	ANTENNA HEIGHT (m)	TABLE ANGLE (Degree)	RAW VALUE (dBuV)	CORRECTION FACTOR (dB/m)
1	*5710.00	110.6 PK			1.00 H	207	106.4	4.2
2	*5710.00	101.4 AV			1.00 H	207	97.2	4.2
3	#5850.00	57.1 PK	74.0	-16.9	1.00 H	207	52.9	4.2
4	#5850.00	44.3 AV	54.0	-9.7	1.00 H	207	40.1	4.2
5	11420.00	50.6 PK	74.0	-23.4	1.75 H	197	35.2	15.4
6	11420.00	38.9 AV	54.0	-15.1	1.75 H	197	23.5	15.4
7	#17130.00	52.1 PK	74.0	-21.9	1.42 H	187	32.1	20.0
8	#17130.00	39.6 AV	54.0	-14.4	1.42 H	187	19.6	20.0

**ANTENNA POLARITY & TEST DISTANCE: VERTICAL AT 3 M**

NO.	FREQ. (MHz)	EMISSION LEVEL (dBuV/m)	LIMIT (dBuV/m)	MARGIN (dB)	ANTENNA HEIGHT (m)	TABLE ANGLE (Degree)	RAW VALUE (dBuV)	CORRECTION FACTOR (dB/m)
1	*5710.00	109.2 PK			2.63 V	183	105.0	4.2
2	*5710.00	99.8 AV			2.63 V	183	95.6	4.2
3	#5850.00	67.2 PK	74.0	-6.8	2.63 V	183	63.0	4.2
4	#5850.00	41.0 AV	54.0	-13.0	2.63 V	183	36.8	4.2
5	11420.00	50.3 PK	74.0	-23.7	1.67 V	177	34.9	15.4
6	11420.00	39.0 AV	54.0	-15.0	1.67 V	177	23.6	15.4
7	#17130.00	53.5 PK	74.0	-20.5	2.15 V	290	33.5	20.0
8	#17130.00	41.0 AV	54.0	-13.0	2.15 V	290	21.0	20.0

**REMARKS:**

1. Emission Level(dBuV/m) = Raw Value(dBuV) + Correction Factor(dB/m)
2. Correction Factor(dB/m) = Antenna Factor(dB/m) + Cable Factor(dB) – Pre-Amplifier Factor(dB)
3. The other emission levels were very low against the limit.
4. Margin value = Emission Level – Limit value
5. " \* ": Fundamental frequency.
6. " # ": The radiated frequency is out of the restricted band.

<b>CHANNEL</b>	TX Channel 151	<b>DETECTOR FUNCTION</b>	Peak (PK)
<b>FREQUENCY RANGE</b>	1GHz ~ 40GHz		Average (AV)

**ANTENNA POLARITY & TEST DISTANCE: HORIZONTAL AT 3 M**

NO.	FREQ. (MHz)	EMISSION LEVEL (dBuV/m)	LIMIT (dBuV/m)	MARGIN (dB)	ANTENNA HEIGHT (m)	TABLE ANGLE (Degree)	RAW VALUE (dBuV)	CORRECTION FACTOR (dB/m)
1	#5583.06	61.0 PK	68.2	-7.2	1.05 H	205	57.1	3.9
2	*5755.00	114.2 PK			1.05 H	205	110.0	4.2
3	*5755.00	104.1 AV			1.05 H	205	99.9	4.2
4	#5954.09	61.0 PK	68.2	-7.2	1.05 H	205	56.6	4.4
5	11510.00	50.4 PK	74.0	-23.6	1.69 H	188	35.3	15.1
6	11510.00	38.8 AV	54.0	-15.2	1.69 H	188	23.7	15.1
7	#17265.00	52.5 PK	74.0	-21.5	1.40 H	182	32.6	19.9
8	#17265.00	39.9 AV	54.0	-14.1	1.40 H	182	20.0	19.9

**ANTENNA POLARITY & TEST DISTANCE: VERTICAL AT 3 M**

NO.	FREQ. (MHz)	EMISSION LEVEL (dBuV/m)	LIMIT (dBuV/m)	MARGIN (dB)	ANTENNA HEIGHT (m)	TABLE ANGLE (Degree)	RAW VALUE (dBuV)	CORRECTION FACTOR (dB/m)
1	#5647.65	61.0 PK	68.2	-7.2	2.44 V	152	57.0	4.0
2	*5755.00	109.4 PK			2.44 V	152	105.2	4.2
3	*5755.00	99.4 AV			2.44 V	152	95.2	4.2
4	#6016.73	60.0 PK	68.2	-8.2	2.44 V	152	55.5	4.5
5	11510.00	50.1 PK	74.0	-23.9	1.61 V	164	35.0	15.1
6	11510.00	38.3 AV	54.0	-15.7	1.61 V	164	23.2	15.1
7	#17265.00	52.9 PK	74.0	-21.1	2.13 V	289	33.0	19.9
8	#17265.00	40.7 AV	54.0	-13.3	2.13 V	289	20.8	19.9

**REMARKS:**

1. Emission Level(dBuV/m) = Raw Value(dBuV) + Correction Factor(dB/m)
2. Correction Factor(dB/m) = Antenna Factor(dB/m) + Cable Factor(dB) – Pre-Amplifier Factor(dB)
3. The other emission levels were very low against the limit.
4. Margin value = Emission Level – Limit value
5. " \* ": Fundamental frequency.
6. " # ": The radiated frequency is out of the restricted band.

<b>CHANNEL</b>	TX Channel 159	<b>DETECTOR FUNCTION</b>	Peak (PK)
<b>FREQUENCY RANGE</b>	1GHz ~ 40GHz		Average (AV)

**ANTENNA POLARITY & TEST DISTANCE: HORIZONTAL AT 3 M**

NO.	FREQ. (MHz)	EMISSION LEVEL (dBuV/m)	LIMIT (dBuV/m)	MARGIN (dB)	ANTENNA HEIGHT (m)	TABLE ANGLE (Degree)	RAW VALUE (dBuV)	CORRECTION FACTOR (dB/m)
1	#5631.87	60.2 PK	68.2	-8.0	1.10 H	210	56.2	4.0
2	*5795.00	113.8 PK			1.10 H	210	109.7	4.1
3	*5795.00	103.9 AV			1.10 H	210	99.8	4.1
4	#5932.23	63.4 PK	68.2	-4.8	1.10 H	210	59.0	4.4
5	11590.00	49.9 PK	74.0	-24.1	1.65 H	165	34.8	15.1
6	11590.00	38.3 AV	54.0	-15.7	1.65 H	165	23.2	15.1
7	#17385.00	51.8 PK	74.0	-22.2	1.40 H	179	31.2	20.6
8	#17385.00	39.7 AV	54.0	-14.3	1.40 H	179	19.1	20.6

**ANTENNA POLARITY & TEST DISTANCE: VERTICAL AT 3 M**

NO.	FREQ. (MHz)	EMISSION LEVEL (dBuV/m)	LIMIT (dBuV/m)	MARGIN (dB)	ANTENNA HEIGHT (m)	TABLE ANGLE (Degree)	RAW VALUE (dBuV)	CORRECTION FACTOR (dB/m)
1	#5571.20	59.6 PK	68.2	-8.6	2.49 V	143	55.7	3.9
2	*5795.00	108.5 PK			2.49 V	143	104.4	4.1
3	*5795.00	98.4 AV			2.49 V	143	94.3	4.1
4	#5948.82	60.1 PK	68.2	-8.1	2.49 V	143	55.7	4.4
5	11590.00	50.4 PK	74.0	-23.6	1.64 V	183	35.3	15.1
6	11590.00	38.7 AV	54.0	-15.3	1.64 V	183	23.6	15.1
7	#17385.00	53.1 PK	74.0	-20.9	2.18 V	291	32.5	20.6
8	#17385.00	40.9 AV	54.0	-13.1	2.18 V	291	20.3	20.6

**REMARKS:**

1. Emission Level(dBuV/m) = Raw Value(dBuV) + Correction Factor(dB/m)
2. Correction Factor(dB/m) = Antenna Factor(dB/m) + Cable Factor(dB) – Pre-Amplifier Factor(dB)
3. The other emission levels were very low against the limit.
4. Margin value = Emission Level – Limit value
5. " \* ": Fundamental frequency.
6. " # ": The radiated frequency is out of the restricted band.

**802.11ac (VHT80)**

<b>CHANNEL</b>	TX Channel 42	<b>DETECTOR FUNCTION</b>	Peak (PK)
<b>FREQUENCY RANGE</b>	1GHz ~ 40GHz		Average (AV)

**ANTENNA POLARITY & TEST DISTANCE: HORIZONTAL AT 3 M**

NO.	FREQ. (MHz)	EMISSION LEVEL (dBuV/m)	LIMIT (dBuV/m)	MARGIN (dB)	ANTENNA HEIGHT (m)	TABLE ANGLE (Degree)	RAW VALUE (dBuV)	CORRECTION FACTOR (dB/m)
1	5150.00	67.3 PK	74.0	-6.7	1.01 H	198	64.3	3.0
2	5150.00	53.1 AV	54.0	-0.9	1.01 H	198	50.1	3.0
3	*5210.00	106.9 PK			1.01 H	198	103.7	3.2
4	*5210.00	96.7 AV			1.01 H	198	93.5	3.2
5	#10420.00	53.4 PK	74.0	-20.6	1.07 H	193	39.6	13.8
6	#10420.00	39.4 AV	54.0	-14.6	1.07 H	193	25.6	13.8
7	15630.00	51.5 PK	74.0	-22.5	1.53 H	176	35.8	15.7
8	15630.00	39.5 AV	54.0	-14.5	1.53 H	176	23.8	15.7

**ANTENNA POLARITY & TEST DISTANCE: VERTICAL AT 3 M**

NO.	FREQ. (MHz)	EMISSION LEVEL (dBuV/m)	LIMIT (dBuV/m)	MARGIN (dB)	ANTENNA HEIGHT (m)	TABLE ANGLE (Degree)	RAW VALUE (dBuV)	CORRECTION FACTOR (dB/m)
1	5150.00	65.1 PK	74.0	-8.9	2.60 V	177	62.1	3.0
2	5150.00	48.8 AV	54.0	-5.2	2.60 V	177	45.8	3.0
3	*5210.00	102.1 PK			2.60 V	177	98.9	3.2
4	*5210.00	92.3 AV			2.60 V	177	89.1	3.2
5	#10420.00	50.3 PK	74.0	-23.7	1.60 V	163	36.5	13.8
6	#10420.00	38.7 AV	54.0	-15.3	1.60 V	163	24.9	13.8
7	15630.00	52.5 PK	74.0	-21.5	2.20 V	310	36.8	15.7
8	15630.00	40.3 AV	54.0	-13.7	2.20 V	310	24.6	15.7

**REMARKS:**

- Emission Level(dBuV/m) = Raw Value(dBuV) + Correction Factor(dB/m)
- Correction Factor(dB/m) = Antenna Factor(dB/m) + Cable Factor(dB) – Pre-Amplifier Factor(dB)
- The other emission levels were very low against the limit.
- Margin value = Emission Level – Limit value
- " \* ": Fundamental frequency.
- " # ": The radiated frequency is out of the restricted band.

<b>CHANNEL</b>	TX Channel 58	<b>DETECTOR FUNCTION</b>	Peak (PK)
<b>FREQUENCY RANGE</b>	1GHz ~ 40GHz		Average (AV)

**ANTENNA POLARITY & TEST DISTANCE: HORIZONTAL AT 3 M**

NO.	FREQ. (MHz)	EMISSION LEVEL (dBuV/m)	LIMIT (dBuV/m)	MARGIN (dB)	ANTENNA HEIGHT (m)	TABLE ANGLE (Degree)	RAW VALUE (dBuV)	CORRECTION FACTOR (dB/m)
1	*5290.00	107.8 PK			1.00 H	200	104.5	3.3
2	*5290.00	97.4 AV			1.00 H	200	94.1	3.3
3	5350.00	69.3 PK	74.0	-4.7	1.00 H	200	65.8	3.5
4	<b>5350.00</b>	<b>53.9 AV</b>	<b>54.0</b>	<b>-0.1</b>	<b>1.00 H</b>	<b>200</b>	<b>50.4</b>	<b>3.5</b>
5	#10580.00	53.3 PK	74.0	-20.7	1.01 H	193	39.0	14.3
6	#10580.00	39.7 AV	54.0	-14.3	1.01 H	193	25.4	14.3
7	15870.00	51.5 PK	74.0	-22.5	1.52 H	163	36.5	15.0
8	15870.00	39.5 AV	54.0	-14.5	1.52 H	163	24.5	15.0

**ANTENNA POLARITY & TEST DISTANCE: VERTICAL AT 3 M**

NO.	FREQ. (MHz)	EMISSION LEVEL (dBuV/m)	LIMIT (dBuV/m)	MARGIN (dB)	ANTENNA HEIGHT (m)	TABLE ANGLE (Degree)	RAW VALUE (dBuV)	CORRECTION FACTOR (dB/m)
1	*5290.00	101.9 PK			2.64 V	176	98.6	3.3
2	*5290.00	92.0 AV			2.64 V	176	88.7	3.3
3	5350.00	65.7 PK	74.0	-8.3	2.64 V	176	62.2	3.5
4	5350.00	49.6 AV	54.0	-4.4	2.64 V	176	46.1	3.5
5	#10580.00	50.4 PK	74.0	-23.6	1.67 V	185	36.1	14.3
6	#10580.00	38.7 AV	54.0	-15.3	1.67 V	185	24.4	14.3
7	15870.00	53.3 PK	74.0	-20.7	2.11 V	304	38.3	15.0
8	15870.00	41.0 AV	54.0	-13.0	2.11 V	304	26.0	15.0

**REMARKS:**

1. Emission Level(dBuV/m) = Raw Value(dBuV) + Correction Factor(dB/m)
2. Correction Factor(dB/m) = Antenna Factor(dB/m) + Cable Factor(dB) – Pre-Amplifier Factor(dB)
3. The other emission levels were very low against the limit.
4. Margin value = Emission Level – Limit value
5. " \* ": Fundamental frequency.
6. " # ": The radiated frequency is out of the restricted band.

<b>CHANNEL</b>	TX Channel 106	<b>DETECTOR FUNCTION</b>	Peak (PK)
<b>FREQUENCY RANGE</b>	1GHz ~ 40GHz		Average (AV)

**ANTENNA POLARITY & TEST DISTANCE: HORIZONTAL AT 3 M**

NO.	FREQ. (MHz)	EMISSION LEVEL (dBuV/m)	LIMIT (dBuV/m)	MARGIN (dB)	ANTENNA HEIGHT (m)	TABLE ANGLE (Degree)	RAW VALUE (dBuV)	CORRECTION FACTOR (dB/m)
1	#5470.00	71.6 PK	74.0	-2.4	1.01 H	202	67.9	3.7
2	#5470.00	53.2 AV	54.0	-0.8	1.01 H	202	49.5	3.7
3	*5530.00	105.2 PK			1.01 H	202	101.3	3.9
4	*5530.00	94.9 AV			1.01 H	202	91.0	3.9
5	11060.00	53.0 PK	74.0	-21.0	1.07 H	220	37.9	15.1
6	11060.00	39.3 AV	54.0	-14.7	1.07 H	220	24.2	15.1
7	#16590.00	50.7 PK	74.0	-23.3	1.43 H	173	33.0	17.7
8	#16590.00	38.8 AV	54.0	-15.2	1.43 H	173	21.1	17.7

**ANTENNA POLARITY & TEST DISTANCE: VERTICAL AT 3 M**

NO.	FREQ. (MHz)	EMISSION LEVEL (dBuV/m)	LIMIT (dBuV/m)	MARGIN (dB)	ANTENNA HEIGHT (m)	TABLE ANGLE (Degree)	RAW VALUE (dBuV)	CORRECTION FACTOR (dB/m)
1	#5470.00	68.1 PK	74.0	-5.9	2.60 V	155	64.4	3.7
2	#5470.00	50.1 AV	54.0	-3.9	2.60 V	155	46.4	3.7
3	*5530.00	103.4 PK			2.60 V	155	99.5	3.9
4	*5530.00	93.5 AV			2.60 V	155	89.6	3.9
5	11060.00	50.5 PK	74.0	-23.5	1.61 V	179	35.4	15.1
6	11060.00	38.9 AV	54.0	-15.1	1.61 V	179	23.8	15.1
7	#16590.00	52.6 PK	74.0	-21.4	2.19 V	307	34.9	17.7
8	#16590.00	40.5 AV	54.0	-13.5	2.19 V	307	22.8	17.7

**REMARKS:**

1. Emission Level(dBuV/m) = Raw Value(dBuV) + Correction Factor(dB/m)
2. Correction Factor(dB/m) = Antenna Factor(dB/m) + Cable Factor(dB) – Pre-Amplifier Factor(dB)
3. The other emission levels were very low against the limit.
4. Margin value = Emission Level – Limit value
5. " \* ": Fundamental frequency.
6. " # ": The radiated frequency is out of the restricted band.

<b>CHANNEL</b>	TX Channel 122	<b>DETECTOR FUNCTION</b>	Peak (PK)
<b>FREQUENCY RANGE</b>	1GHz ~ 40GHz		Average (AV)

**ANTENNA POLARITY & TEST DISTANCE: HORIZONTAL AT 3 M**

NO.	FREQ. (MHz)	EMISSION LEVEL (dBuV/m)	LIMIT (dBuV/m)	MARGIN (dB)	ANTENNA HEIGHT (m)	TABLE ANGLE (Degree)	RAW VALUE (dBuV)	CORRECTION FACTOR (dB/m)
1	*5610.00	109.5 PK			1.08 H	203	105.6	3.9
2	*5610.00	98.3 AV			1.08 H	203	94.4	3.9
3	#5725.00	68.5 PK	74.0	-5.5	1.08 H	203	64.3	4.2
4	#5725.00	53.1 AV	54.0	-0.9	1.08 H	203	48.9	4.2
5	11220.00	49.9 PK	74.0	-24.1	1.64 H	153	34.7	15.2
6	11220.00	38.3 AV	54.0	-15.7	1.64 H	153	23.1	15.2
7	#16830.00	53.0 PK	74.0	-21.0	1.45 H	179	34.5	18.5
8	#16830.00	40.5 AV	54.0	-13.5	1.45 H	179	22.0	18.5

**ANTENNA POLARITY & TEST DISTANCE: VERTICAL AT 3 M**

NO.	FREQ. (MHz)	EMISSION LEVEL (dBuV/m)	LIMIT (dBuV/m)	MARGIN (dB)	ANTENNA HEIGHT (m)	TABLE ANGLE (Degree)	RAW VALUE (dBuV)	CORRECTION FACTOR (dB/m)
1	*5610.00	106.2 PK			2.59 V	151	102.3	3.9
2	*5610.00	95.2 AV			2.59 V	151	91.3	3.9
3	#5725.00	65.8 PK	74.0	-8.2	2.59 V	151	61.6	4.2
4	#5725.00	50.1 AV	54.0	-3.9	2.59 V	151	45.9	4.2
5	11220.00	50.4 PK	74.0	-23.6	1.62 V	172	35.2	15.2
6	11220.00	38.8 AV	54.0	-15.2	1.62 V	172	23.6	15.2
7	#16830.00	53.1 PK	74.0	-20.9	2.21 V	296	34.6	18.5
8	#16830.00	40.9 AV	54.0	-13.1	2.21 V	296	22.4	18.5

**REMARKS:**

1. Emission Level(dBuV/m) = Raw Value(dBuV) + Correction Factor(dB/m)
2. Correction Factor(dB/m) = Antenna Factor(dB/m) + Cable Factor(dB) – Pre-Amplifier Factor(dB)
3. The other emission levels were very low against the limit.
4. Margin value = Emission Level – Limit value
5. " \* ": Fundamental frequency.
6. " # ": The radiated frequency is out of the restricted band.



<b>CHANNEL</b>	TX Channel 138	<b>DETECTOR FUNCTION</b>	Peak (PK)
<b>FREQUENCY RANGE</b>	1GHz ~ 40GHz		Average (AV)

**ANTENNA POLARITY & TEST DISTANCE: HORIZONTAL AT 3 M**

NO.	FREQ. (MHz)	EMISSION LEVEL (dBuV/m)	LIMIT (dBuV/m)	MARGIN (dB)	ANTENNA HEIGHT (m)	TABLE ANGLE (Degree)	RAW VALUE (dBuV)	CORRECTION FACTOR (dB/m)
1	*5690.00	109.1 PK			1.07 H	204	104.9	4.2
2	*5690.00	98.1 AV			1.07 H	204	93.9	4.2
3	#5850.00	63.1 PK	74.0	-10.9	1.07 H	204	58.9	4.2
4	#5850.00	47.3 AV	54.0	-6.7	1.07 H	204	43.1	4.2
5	11380.00	50.2 PK	74.0	-23.8	1.57 H	152	34.8	15.4
6	11380.00	38.7 AV	54.0	-15.3	1.57 H	152	23.3	15.4
7	#17070.00	52.4 PK	74.0	-21.6	1.42 H	181	32.4	20.0
8	#17070.00	39.9 AV	54.0	-14.1	1.42 H	181	19.9	20.0

**ANTENNA POLARITY & TEST DISTANCE: VERTICAL AT 3 M**

NO.	FREQ. (MHz)	EMISSION LEVEL (dBuV/m)	LIMIT (dBuV/m)	MARGIN (dB)	ANTENNA HEIGHT (m)	TABLE ANGLE (Degree)	RAW VALUE (dBuV)	CORRECTION FACTOR (dB/m)
1	*5690.00	105.7 PK			2.59 V	170	101.5	4.2
2	*5690.00	94.8 AV			2.59 V	170	90.6	4.2
3	#5850.00	67.1 PK	74.0	-6.9	2.59 V	170	62.9	4.2
4	#5850.00	41.1 AV	54.0	-12.9	2.59 V	170	36.9	4.2
5	11380.00	50.6 PK	74.0	-23.4	1.61 V	179	35.2	15.4
6	11380.00	39.1 AV	54.0	-14.9	1.61 V	179	23.7	15.4
7	#17070.00	52.4 PK	74.0	-21.6	2.12 V	315	32.4	20.0
8	#17070.00	40.3 AV	54.0	-13.7	2.12 V	315	20.3	20.0

**REMARKS:**

1. Emission Level(dBuV/m) = Raw Value(dBuV) + Correction Factor(dB/m)
2. Correction Factor(dB/m) = Antenna Factor(dB/m) + Cable Factor(dB) – Pre-Amplifier Factor(dB)
3. The other emission levels were very low against the limit.
4. Margin value = Emission Level – Limit value
5. " \* ": Fundamental frequency.
6. " # ": The radiated frequency is out of the restricted band.

<b>CHANNEL</b>	TX Channel 155	<b>DETECTOR FUNCTION</b>	Peak (PK)
<b>FREQUENCY RANGE</b>	1GHz ~ 40GHz		Average (AV)

**ANTENNA POLARITY & TEST DISTANCE: HORIZONTAL AT 3 M**

NO.	FREQ. (MHz)	EMISSION LEVEL (dBuV/m)	LIMIT (dBuV/m)	MARGIN (dB)	ANTENNA HEIGHT (m)	TABLE ANGLE (Degree)	RAW VALUE (dBuV)	CORRECTION FACTOR (dB/m)
1	#5650.83	67.8 PK	68.8	-1.0	1.09 H	202	63.8	4.0
2	*5775.00	111.3 PK			1.09 H	202	107.1	4.2
3	*5775.00	101.1 AV			1.09 H	202	96.9	4.2
4	#5926.56	65.3 PK	68.2	-2.9	1.09 H	202	60.9	4.4
5	11550.00	50.2 PK	74.0	-23.8	1.67 H	189	35.0	15.2
6	11550.00	38.5 AV	54.0	-15.5	1.67 H	189	23.3	15.2
7	#17325.00	52.5 PK	74.0	-21.5	1.37 H	183	32.2	20.3
8	#17325.00	40.3 AV	54.0	-13.7	1.37 H	183	20.0	20.3

**ANTENNA POLARITY & TEST DISTANCE: VERTICAL AT 3 M**

NO.	FREQ. (MHz)	EMISSION LEVEL (dBuV/m)	LIMIT (dBuV/m)	MARGIN (dB)	ANTENNA HEIGHT (m)	TABLE ANGLE (Degree)	RAW VALUE (dBuV)	CORRECTION FACTOR (dB/m)
1	#5646.75	63.4 PK	68.2	-4.8	2.45 V	176	59.4	4.0
2	*5775.00	105.6 PK			2.45 V	176	101.4	4.2
3	*5775.00	95.0 AV			2.45 V	176	90.8	4.2
4	#5931.52	59.9 PK	68.2	-8.3	2.45 V	176	55.5	4.4
5	11550.00	49.5 PK	74.0	-24.5	1.65 V	177	34.3	15.2
6	11550.00	38.3 AV	54.0	-15.7	1.65 V	177	23.1	15.2
7	#17325.00	52.8 PK	74.0	-21.2	2.10 V	298	32.5	20.3
8	#17325.00	40.7 AV	54.0	-13.3	2.10 V	298	20.4	20.3

**REMARKS:**

1. Emission Level(dBuV/m) = Raw Value(dBuV) + Correction Factor(dB/m)
2. Correction Factor(dB/m) = Antenna Factor(dB/m) + Cable Factor(dB) – Pre-Amplifier Factor(dB)
3. The other emission levels were very low against the limit.
4. Margin value = Emission Level – Limit value
5. " \* ": Fundamental frequency.
6. " # ": The radiated frequency is out of the restricted band.

**Below 1GHz Data:**

**802.11ac (VHT40)**

<b>CHANNEL</b>	TX Channel 151	<b>DETECTOR FUNCTION</b>	Quasi-Peak (QP)
<b>FREQUENCY RANGE</b>	9kHz ~ 1GHz		

**ANTENNA POLARITY & TEST DISTANCE: HORIZONTAL AT 3 M**

NO.	FREQ. (MHz)	EMISSION LEVEL (dBuV/m)	LIMIT (dBuV/m)	MARGIN (dB)	ANTENNA HEIGHT (m)	TABLE ANGLE (Degree)	RAW VALUE (dBuV)	CORRECTION FACTOR (dB/m)
1	98.70	30.6 QP	43.5	-12.9	2.00 H	101	43.5	-12.9
2	125.01	34.5 QP	43.5	-9.0	1.50 H	198	44.7	-10.2
3	320.01	24.0 QP	46.0	-22.0	1.50 H	319	30.7	-6.7
4	375.00	40.9 QP	46.0	-5.1	1.00 H	345	46.4	-5.5
5	468.12	30.6 QP	46.0	-15.4	2.00 H	173	33.7	-3.1
6	625.02	39.8 QP	46.0	-6.2	1.50 H	356	39.3	0.5

**ANTENNA POLARITY & TEST DISTANCE: VERTICAL AT 3 M**

NO.	FREQ. (MHz)	EMISSION LEVEL (dBuV/m)	LIMIT (dBuV/m)	MARGIN (dB)	ANTENNA HEIGHT (m)	TABLE ANGLE (Degree)	RAW VALUE (dBuV)	CORRECTION FACTOR (dB/m)
1	39.26	36.4 QP	40.0	-3.6	1.00 V	114	44.8	-8.4
2	117.37	29.2 QP	43.5	-14.3	2.00 V	0	40.0	-10.8
3	165.58	26.9 QP	43.5	-16.6	1.00 V	2	34.8	-7.9
4	375.00	36.7 QP	46.0	-9.3	1.00 V	360	42.2	-5.5
5	465.14	26.7 QP	46.0	-19.3	2.00 V	286	29.7	-3.0
6	625.02	37.8 QP	46.0	-8.2	1.50 V	300	37.3	0.5

**REMARKS:**

1. Emission Level(dBuV/m) = Raw Value(dBuV) + Correction Factor(dB/m)
2. Correction Factor(dB/m) = Antenna Factor(dB/m) + Cable Factor(dB) – Pre-Amplifier Factor(dB)
3. The other emission levels were very low against the limit.
4. Margin value = Emission Level – Limit value

## 4.2 Conducted Emission Measurement

### 4.2.1 Limits of Conducted Emission Measurement

Frequency (MHz)	Conducted Limit (dBuV)	
	Quasi-peak	Average
0.15 - 0.5	66 - 56	56 - 46
0.50 - 5.0	56	46
5.0 - 30.0	60	50

Note: 1. The lower limit shall apply at the transition frequencies.

2. The limit decreases in line with the logarithm of the frequency in the range of 0.15 to 0.50MHz.

### 4.2.2 Test Instruments

DESCRIPTION & MANUFACTURER	MODEL NO.	SERIAL NO.	CALIBRATED DATE	CALIBRATED UNTIL
Test Receiver R&S	ESCS 30	847124/029	Oct. 24, 2016	Oct. 23, 2017
Line-Impedance Stabilization Network (for EUT) R&S	ESH3-Z5	848773/004	Oct. 26, 2016	Oct. 25, 2017
RF Cable	5D-FB	COCCAB-001	Sep. 30, 2016	Sep. 29, 2017
10 dB PAD Mini-Circuits	HAT-10+	CONATT-004	June 20, 2016	June 19, 2017
Software BVADT	BVADT_Cond_ V7.3.7.4	NA	NA	NA

**Note:**

1. The calibration interval of the above test instruments are 12 months and the calibrations are traceable to NML/ROC and NIST/USA.
2. The test was performed in Shielded Room No. 1.
- 3 Tested Date: Nov. 22, 2016

#### 4.2.3 Test Procedure

- The EUT was placed 0.4 meters from the conducting wall of the shielded room with EUT being connected to the power mains through a line impedance stabilization network (LISN). Other support units were connected to the power mains through another LISN. The two LISNs provide 50 ohm/ 50uH of coupling impedance for the measuring instrument.
- Both lines of the power mains connected to the EUT were checked for maximum conducted interference.
- The frequency range from 150kHz to 30MHz was searched. Emission levels under (Limit - 20dB) was not recorded.

**NOTE:** All modes of operation were investigated and the worst-case emissions are reported.

#### 4.2.4 Deviation from Test Standard

No deviation.

#### 4.2.5 Test Setup

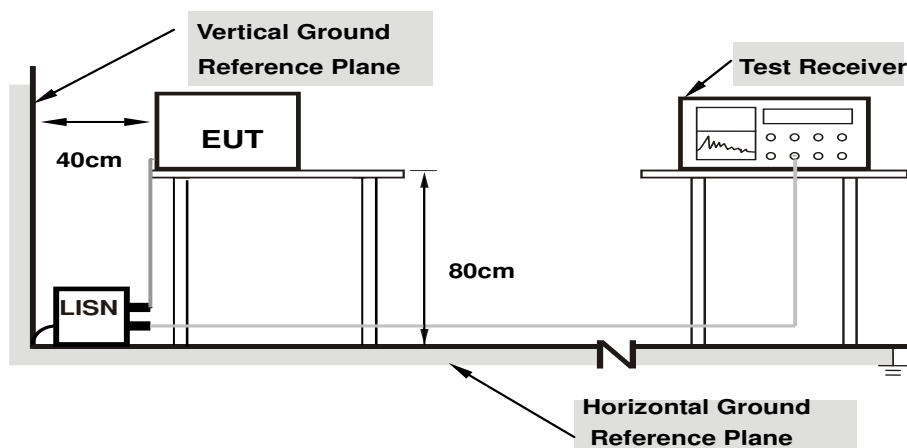

**Note: 1.Support units were connected to second LISN.**

**2.Both of LISNs (AMN) are 80 cm from EUT and at least 80 from other units and other metal planes**

For the actual test configuration, please refer to the attached file (Test Setup Photo).

#### 4.2.6 EUT Operating Condition

Same as 4.1.6.

#### 4.2.7 Test Results

Phase	Line (L)	Detector Function	Quasi-Peak (QP) / Average (AV)
-------	----------	-------------------	--------------------------------

Phase Of Power : Line (L)										
No	Frequency (MHz)	Correction Factor (dB)	Reading Value (dBuV)		Emission Level (dBuV)		Limit (dBuV)		Margin (dB)	
			Q.P.	AV.	Q.P.	AV.	Q.P.	AV.	Q.P.	AV.
1	0.15391	10.20	35.92	17.62	46.12	27.82	65.79	55.79	-19.67	-27.97
2	0.27109	10.21	28.53	8.04	38.74	18.25	61.08	51.08	-22.34	-32.83
3	0.35703	10.23	30.17	15.36	40.40	25.59	58.80	48.80	-18.40	-23.21
4	1.48047	10.30	20.51	7.29	30.81	17.59	56.00	46.00	-25.19	-28.41
5	9.42188	10.69	21.70	14.64	32.39	25.33	60.00	50.00	-27.61	-24.67
6	15.32031	11.33	28.19	21.48	39.52	32.81	60.00	50.00	-20.48	-17.19

**Remarks:**

1. Q.P. and AV. are abbreviations of quasi-peak and average individually.
2. The emission levels of other frequencies were very low against the limit.
3. Margin value = Emission level – Limit value
4. Correction factor = Insertion loss + Cable loss
5. Emission Level = Correction Factor + Reading Value

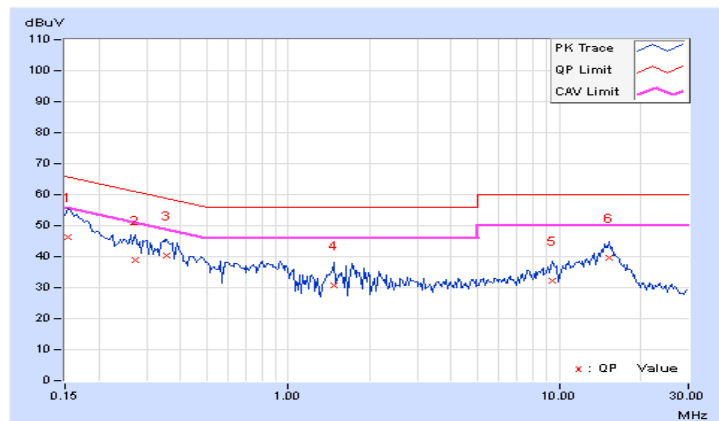

Phase	Neutral (N)	Detector Function	Quasi-Peak (QP) / Average (AV)
-------	-------------	-------------------	--------------------------------

Phase Of Power : Neutral (N)										
No	Frequency (MHz)	Correction Factor (dB)	Reading Value (dBuV)		Emission Level (dBuV)		Limit (dBuV)		Margin (dB)	
			Q.P.	AV.	Q.P.	AV.	Q.P.	AV.	Q.P.	AV.
1	0.16172	10.19	38.84	26.81	49.03	37.00	65.38	55.38	-16.35	-18.38
2	0.18125	10.18	31.10	12.79	41.28	22.97	64.43	54.43	-23.15	-31.46
<b>3</b>	<b>0.38828</b>	<b>10.24</b>	<b>32.39</b>	<b>21.63</b>	<b>42.63</b>	<b>31.87</b>	<b>58.10</b>	<b>48.10</b>	<b>-15.47</b>	<b>-16.23</b>
4	0.43906	10.24	29.04	18.62	39.28	28.86	57.08	47.08	-17.80	-18.22
5	1.77344	10.30	26.51	17.49	36.81	27.79	56.00	46.00	-19.19	-18.21
6	15.51172	11.12	28.00	21.21	39.12	32.33	60.00	50.00	-20.88	-17.67

**Remarks:**

1. Q.P. and AV. are abbreviations of quasi-peak and average individually.
2. The emission levels of other frequencies were very low against the limit.
3. Margin value = Emission level – Limit value
4. Correction factor = Insertion loss + Cable loss
5. Emission Level = Correction Factor + Reading Value

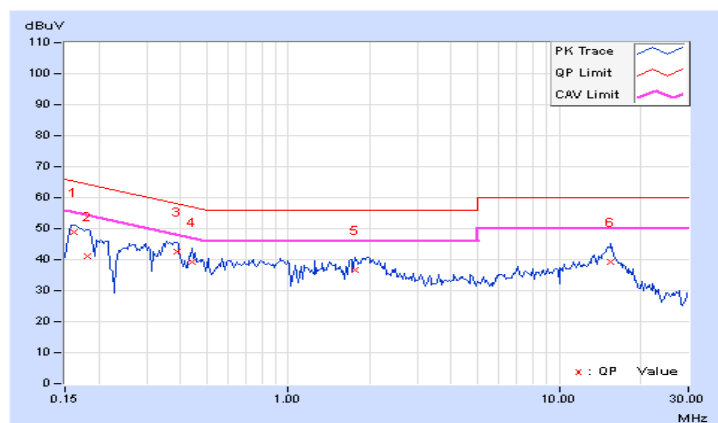

### 4.3 Transmit Power Measurement

#### 4.3.1 Limits of Transmit Power Measurement

Operation Band	EUT Category		Limit
U-NII-1		Outdoor Access Point	1 Watt (30 dBm) (Max. e.i.r.p $\leq$ 125mW(21 dBm) at any elevation angle above 30 degrees as measured from the horizon)
		Fixed point-to-point Access Point	1 Watt (30 dBm)
		Indoor Access Point	1 Watt (30 dBm)
	√	Mobile and Portable client device	250mW (24 dBm)
U-NII-2A		√	250mW (24 dBm) or 11 dBm+10 log B*
U-NII-2C		√	250mW (24 dBm) or 11 dBm+10 log B*
U-NII-3		√	1 Watt (30 dBm)

\*B is the 26 dB emission bandwidth in megahertz

Per KDB 662911 Method of conducted output power measurement on IEEE 802.11 devices,

Array Gain = 0 dB (i.e., no array gain) for  $N_{ANT} \leq 4$ ;

Array Gain = 0 dB (i.e., no array gain) for channel widths  $\geq 40$  MHz for any  $N_{ANT}$ ;

Array Gain =  $5 \log(N_{ANT}/N_{SS})$  dB or 3 dB, whichever is less for 20-MHz channel widths with  $N_{ANT} \geq 5$ .

For power measurements on all other devices: Array Gain =  $10 \log(N_{ANT}/N_{SS})$  dB.



#### 4.3.2 Test Setup

##### FOR POWER OUTPUT MEASUREMENT

For channel straddling 5725MHz:

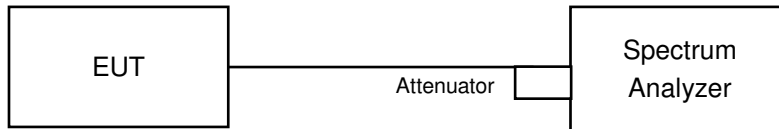

For other channels:

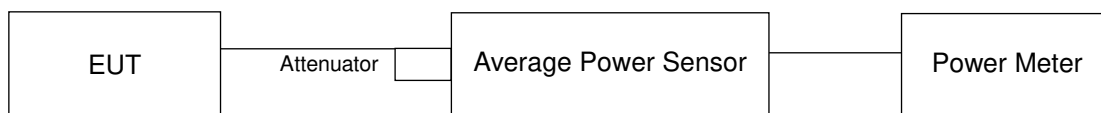

##### FOR 26dB OCCUPIED BANDWIDTH

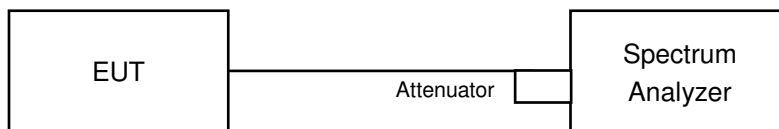

#### 4.3.3 Test Instruments

Refer to section 4.1.2 to get information of above instrument.

#### 4.3.4 Test Procedure

##### FOR AVERAGE POWER MEASUREMENT

###### For channel straddling 5725MHz:

Method SA-1

1. Set span to encompass the entire emission bandwidth (EBW) of the signal.
2. Set RBW =1MHz.
3. Set the VBW  $\geq 3 \times$  RBW.
4. Number of points in sweep  $\geq 2$  Span / RBW.
5. Sweep time = auto.
6. Set trigger to free run (duty cycle  $\geq 98$  percent)
7. Detector = RMS.
8. Trace average at least 100 traces in power averaging mode
9. Compute power by integrating the spectrum across the 26 dB EBW of the signal.

###### For other channels:

Method PM is used to perform output power measurement, trigger and gating function of wide band power meter is enabled to measure max output power of TX on burst. Duty factor is not added to measured value.

##### FOR 26dB OCCUPIED BANDWIDTH

1. Set RBW = approximately 1% of the emission bandwidth.
2. Set the VBW  $>$  RBW.
3. Detector = Peak.
4. Trace mode = max hold.
5. Measure the maximum width of the emission that is 26 dB down from the peak of the emission. Compare this with the RBW setting of the analyzer. Readjust RBW and repeat measurement as needed until the RBW/EBW ratio is approximately 1%.

#### 4.3.5 Deviation from Test Standard

No deviation.

#### 4.3.6 EUT Operating Condition

The software provided by client to enable the EUT under transmission condition continuously at lowest, middle and highest channel frequencies individually.

#### 4.3.7 Test Result

#### CDD Mode

#### 802.11a

Chan.	Chan. Freq. (MHz)	Average Power (dBm)		Total Power (mW)	Total Power (dBm)	Limit (dBm)	Pass / Fail
		Chain 0	Chain 1				
36	5180	20.93	20.96	248.618	23.96	24.00	Pass
40	5200	20.91	20.95	247.761	23.94	24.00	Pass
48	5240	20.93	20.97	248.906	23.96	24.00	Pass
52	5260	20.47	20.53	224.409	23.51	24.00	Pass
60	5300	20.89	20.91	246.054	23.91	24.00	Pass
64	5320	20.90	20.92	246.622	23.92	24.00	Pass
100	5500	19.38	19.98	186.237	22.70	24.00	Pass
116	5580	20.71	20.95	242.212	23.84	24.00	Pass
140	5700	20.03	19.57	191.266	22.82	24.00	Pass
*144 (UNII-2C Band)	5720	16.72	16.68	93.548	19.71	23.31	Pass
*144 (UNII-3 Band)	5720	10.55	9.94	21.213	13.27	30.00	Pass
149	5745	21.44	20.82	260.097	24.15	30.00	Pass
157	5785	21.01	20.33	234.078	23.69	30.00	Pass
165	5825	20.52	20.13	215.759	23.34	30.00	Pass

Note: \* Test was performed in accordance with Measurement follow FCC KDB 789033 UNII test procedure Method SA-1 and use spectrum analyzer test.

The Total Power for the straddle channel:

Chan.	Chan. Freq. (MHz)	Average Power (mW)	Average Power (dBm)
144	5720	114.761	20.6

Note: The total power was calculated through formula and record the value for reference only.

### 26dB OCCUPIED BANDWIDTH

Channel	Frequency (MHz)	26dBc Bandwidth (MHz)	
		Chain 0	Chain 1
52	5260	23.89	25.03
60	5300	23.41	24.94
64	5320	23.22	24.22
100	5500	23.48	23.71
116	5580	23.37	23.53
140	5700	23.46	23.62
*144 (UNII-2C Band)	5720	17.27	17.06

**Note: For U-NII-2A Band output power limitation is determined based on 26dBc bandwidth.**

Power Limit = 11dBm + 10logB < U-NII-2A, U-NII-2C >			
Channel Number	Freq.(MHz)	Min. B(MHz)	Determined Conducted Limit (dBm)
52	5260	23.89	24.78 > 24
60	5300	23.41	24.69 > 24
64	5320	23.22	24.65 > 24
100	5500	23.48	24.7 > 24
116	5580	23.37	24.68 > 24
140	5700	23.46	24.7 > 24
144 (UNII-2C Band)	5720	17.06	23.31 < 24

**BF Mode**
**802.11ac (VHT20)**

Chan.	Chan. Freq. (MHz)	Average Power (dBm)		Total Power (mW)	Total Power (dBm)	Limit (dBm)	Pass / Fail
		Chain 0	Chain 1				
36	5180	20.89	20.92	246.339	23.92	24.00	Pass
40	5200	20.83	20.93	244.94	23.89	24.00	Pass
48	5240	20.66	20.82	237.194	23.75	24.00	Pass
52	5260	20.69	20.41	227.121	23.56	24.00	Pass
60	5300	20.93	20.91	247.19	23.93	24.00	Pass
64	5320	20.91	20.89	246.054	23.91	24.00	Pass
100	5500	19.49	19.96	188.003	22.74	24.00	Pass
116	5580	20.72	20.92	241.627	23.83	24.00	Pass
140	5700	19.47	19.53	178.255	22.51	24.00	Pass
*144 (UNII-2C Band)	5720	17.58	17.39	112.108	20.50	23.38	Pass
*144 (UNII-3 Band)	5720	11.90	11.32	29.04	14.63	30.00	Pass
149	5745	21.32	20.89	258.263	24.12	30.00	Pass
157	5785	20.82	20.45	231.698	23.65	30.00	Pass
165	5825	20.57	20.03	214.718	23.32	30.00	Pass

Note: 1.\*Test was performed in accordance with Measurement follow FCC KDB 789033 UNII test procedure Method SA-1 and use spectrum analyzer test.

2. Directional gain =4.93dBi < 6dBi, so the power limit shall not be reduced.

The Total Power for the straddle channel:

Chan.	Chan. Freq. (MHz)	Average Power (mW)	Average Power (dBm)
144	5720	143.297	21.56

Note: The total power was calculated through formula and record the value for reference only.

## 26dB OCCUPIED BANDWIDTH

Channel	Frequency (MHz)	26dBc Bandwidth (MHz)	
		Chain 0	Chain 1
52	5260	26.06	25.88
60	5300	25.56	25.66
64	5320	25.55	25.72
100	5500	25.47	25.14
116	5580	25.08	24.79
140	5700	24.68	24.99
*144 (UNII-2C Band)	5720	17.30	18.14

**Note: For U-NII-2A Band output power limitation is determined based on 26dBc bandwidth.**

Power Limit = 11dBm + 10logB < U-NII-2A, U-NII-2C >			
Channel Number	Freq.(MHz)	Min. B(MHz)	Determined Conducted Limit (dBm)
52	5260	25.88	25.12 > 24
60	5300	25.56	25.07 > 24
64	5320	25.55	25.07 > 24
100	5500	25.14	25.00 > 24
116	5580	24.79	24.94 > 24
140	5700	24.68	24.92 > 24
144 (UNII-2C Band)	5720	17.30	23.38 < 24

**802.11ac (VHT40)**

Chan.	Chan. Freq. (MHz)	Average Power (dBm)		Total Power (mW)	Total Power (dBm)	Limit (dBm)	Pass / Fail
		Chain 0	Chain 1				
38	5190	17.42	17.40	110.162	20.42	24.00	Pass
46	5230	20.81	20.80	240.73	23.82	24.00	Pass
54	5270	20.63	20.68	232.561	23.67	24.00	Pass
62	5310	17.53	17.56	113.64	20.56	24.00	Pass
102	5510	16.81	17.41	103.054	20.13	24.00	Pass
110	5550	20.73	21.13	248.022	23.94	24.00	Pass
134	5670	20.69	20.27	223.634	23.50	24.00	Pass
*142 (UNII-2C Band)	5710	17.53	17.42	111.832	20.49	24.00	Pass
*142 (UNII-3 Band)	5710	8.05	8.09	12.825	11.08	30.00	Pass
151	5755	21.42	21.09	267.205	24.27	30.00	Pass
159	5795	21.17	20.84	252.257	24.02	30.00	Pass

Note: 1.\*Test was performed in accordance with Measurement follow FCC KDB 789033 UNII test procedure Method SA-1 and use spectrum analyzer test.

2. Directional gain =4.93dBi < 6dBi i, so the power limit shall not be reduced limit.

The Total Power for the straddle channel:

Chan.	Chan. Freq. (MHz)	Average Power (mW)	Average Power (dBm)
142	5710	124.657	20.96

Note: The total power was calculated through formula and record the value for reference only.

## 26dB OCCUPIED BANDWIDTH

Channel	Frequency (MHz)	26dBc Bandwidth (MHz)	
		Chain 0	Chain 1
54	5270	45.82	61.24
62	5310	44.34	44.08
102	5510	44.38	43.83
110	5550	44.61	44.23
134	5670	49.01	53.11
*142 (UNII-2C Band)	5710	39.61	37.10

**Note: For U-NII-2A Band output power limitation is determined based on 26dBc bandwidth.**

Power Limit = 11dBm + 10logB < U-NII-2A, U-NII-2C >			
Channel Number	Freq.(MHz)	Min. B(MHz)	Determined Conducted Limit (dBm)
54	5270	45.82	27.61 > 24
62	5310	44.08	27.44 > 24
102	5510	43.83	27.41 > 24
110	5550	44.23	27.45 > 24
134	5670	49.01	27.90 > 24
142 (UNII-2C Band)	5710	37.10	26.69 > 24



**802.11ac (VHT80)**

Chan.	Chan. Freq. (MHz)	Average Power (dBm)		Total Power (mW)	Total Power (dBm)	Limit (dBm)	Pass / Fail
		Chain 0	Chain 1				
42	5210	16.86	16.96	98.188	19.92	24.00	Pass
58	5290	17.41	17.55	111.966	20.49	24.00	Pass
106	5530	16.74	17.01	97.44	19.89	24.00	Pass
122	5610	20.64	20.72	233.91	23.69	24.00	Pass
*138 (UNII-2C Band)	5690	17.96	17.33	116.592	20.67	24.00	Pass
*138 (UNII-3 Band)	5690	4.67	4.58	5.802	7.64	30.00	Pass
155	5775	21.08	20.66	244.646	23.89	30.00	Pass

Note: 1.\*Test was performed in accordance with Measurement follow FCC KDB 789033 UNII test procedure Method SA-1 and use spectrum analyzer test.

2. Directional gain =4.93dBi < 6dBi i, so the power limit shall not be reduced limit.

The Total Power for the straddle channel:

Chan.	Chan. Freq. (MHz)	Average Power (mW)	Average Power (dBm)
138	5690	122.394	20.88

Note: The total power was calculated through formula and record the value for reference only.

### 26dB OCCUPIED BANDWIDTH

Channel	Frequency (MHz)	26dBc Bandwidth (MHz)	
		Chain 0	Chain 1
58	5290	84.06	81.90
106	5530	83.42	82.31
122	5610	99.42	91.34
*138 (UNII-2C Band)	5690	78.69	76.18

**Note: For U-NII-2A Band output power limitation is determined based on 26dBc bandwidth.**

Power Limit = 11dBm + 10logB < U-NII-2A, U-NII-2C >			
Channel Number	Freq.(MHz)	Min. B(MHz)	Determined Conducted Limit (dBm)
58	5290	81.90	30.13 > 24
106	5530	82.31	30.15 > 24
122	5610	91.34	30.60 > 24
138 (UNII-2C Band)	5690	76.18	29.81 > 24

Spectrum Plot of Worst Value

802.11a / Chain 1 - CH144 (UNII-2C Band)

802.11ac (VHT20) / Chain 0 - CH144 (UNII-2C Band)

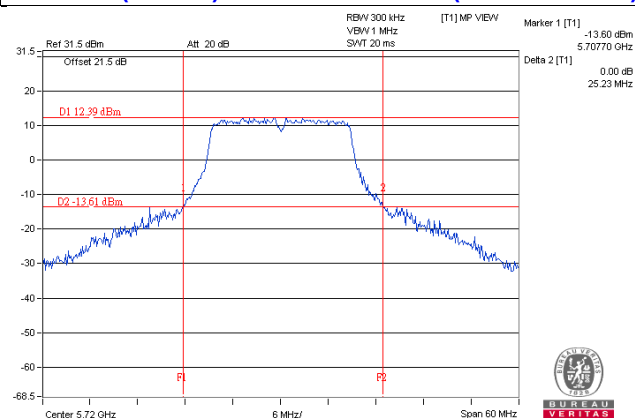
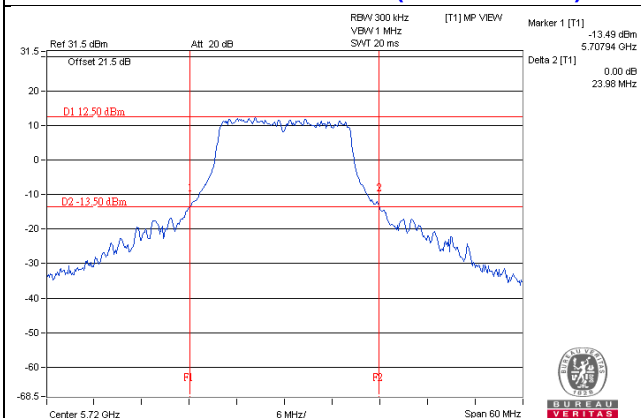

802.11ac (VHT40) / Chain 1 - CH142 (UNII-2C Band)

802.11ac (VHT80) / Chain 1 - CH138 (UNII-2C Band)

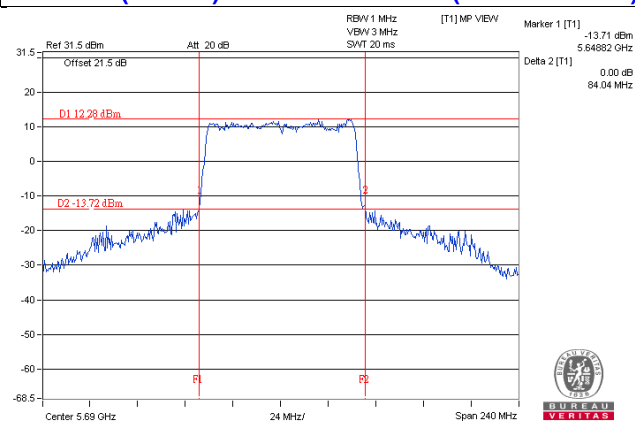
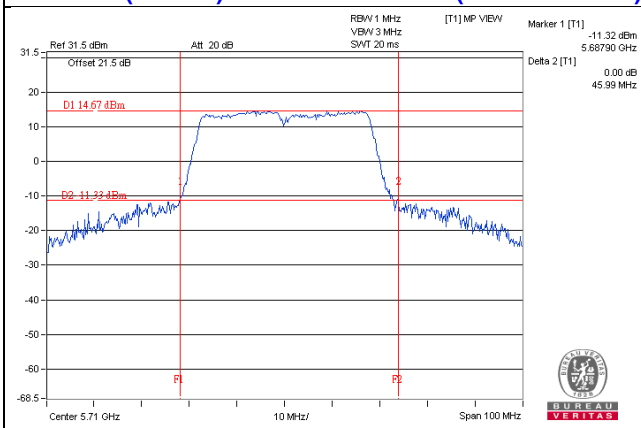

**NOTE:**

- For CH144 (UNII-2C Band) = 5725MHz - Marker 1
- For CH142 (UNII-2C Band) = 5725MHz - Marker 1
- For CH138 (UNII-2C Band) = 5725MHz - Marker 1

## 4.4 Occupied Bandwidth Measurement

### 4.4.1 Test Setup

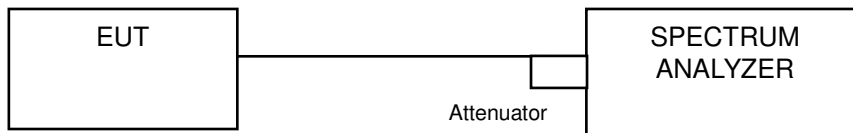

### 4.4.2 Test Instruments

Refer to section 4.1.2 to get information of above instrument.

### 4.4.3 Test Procedure

The transmitter output was connected to the spectrum analyzer through an attenuator. The bandwidth of the fundamental frequency was measured by spectrum analyzer with resolution bandwidth in the range of 1% to 5% of the anticipated emission bandwidth, and a video bandwidth at least 3x the resolution bandwidth and set the detector to SAMPLE. The width of a frequency band such that, below the lower and above the upper frequency limits, the mean powers emitted are each equal to a specified percentage 0.5 %of the total mean power of a given emission.

## 4.4.4 Test Results

## 802.11a

Channel	Channel Frequency (MHz)	Occupied Bandwidth (MHz)	
		Chain 0	Chain 1
36	5180	17.76	18.12
40	5200	18.12	18.36
48	5240	16.92	16.80
52	5260	18.00	18.24
60	5300	17.88	18.24
64	5320	18.12	18.24
100	5500	18.12	18.12
116	5580	17.04	16.80
140	5700	17.88	18.24
*144 (UNII-2C Band)	5720	13.52	13.64
*144 (UNII-3 Band)	5720	3.40	3.40
149	5745	16.92	17.04
157	5785	18.12	18.12
165	5825	18.00	18.36

## 802.11ac (VHT20)

Channel	Channel Frequency (MHz)	Occupied Bandwidth (MHz)	
		Chain 0	Chain 1
36	5180	19.08	19.44
40	5200	19.20	19.20
48	5240	18.24	18.24
52	5260	18.84	19.32
60	5300	19.20	19.20
64	5320	19.08	19.08
100	5500	18.96	18.96
116	5580	18.12	18.12
140	5700	19.20	19.32
*144 (UNII-2C Band)	5720	14.12	14.24
*144 (UNII-3 Band)	5720	4.12	4.00
149	5745	18.36	18.12
157	5785	19.08	19.08
165	5825	19.20	19.20

**802.11ac (VHT40)**

Channel	Channel Frequency (MHz)	Occupied Bandwidth (MHz)	
		Chain 0	Chain 1
38	5190	36.96	36.96
46	5230	36.96	37.44
54	5270	37.20	36.96
62	5310	36.72	36.96
102	5510	36.72	36.72
110	5550	36.72	36.72
134	5670	36.72	36.96
*142 (UNII-2C Band)	5710	33.40	33.40
*142 (UNII-3 Band)	5710	3.40	3.40
151	5755	36.96	36.96
159	5795	37.20	37.20

**802.11ac (VHT80)**

Channel	Channel Frequency (MHz)	Occupied Bandwidth (MHz)	
		Chain 0	Chain 1
42	5210	75.84	75.36
58	5290	75.36	75.36
106	5530	75.36	75.84
122	5610	75.84	75.36
*138 (UNII-2C Band)	5690	72.92	72.92
*138 (UNII-3 Band)	5690	2.92	2.44
155	5775	75.36	75.84

Spectrum Plot of Worst Value

802.11a / Chain 1 – CH40

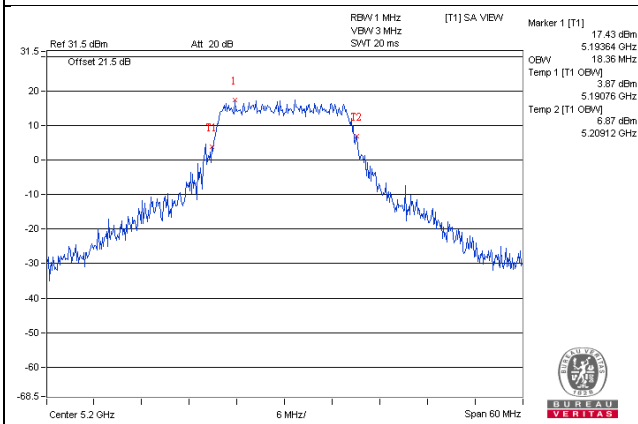

802.11ac (VHT20) / Chain 1 – CH36

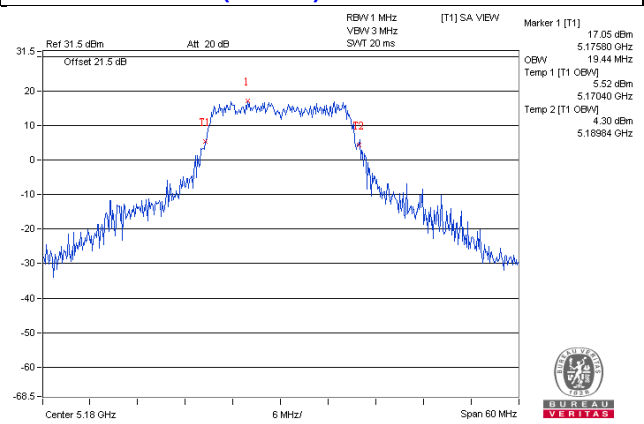

802.11ac (VHT40) / Chain 1 – CH46

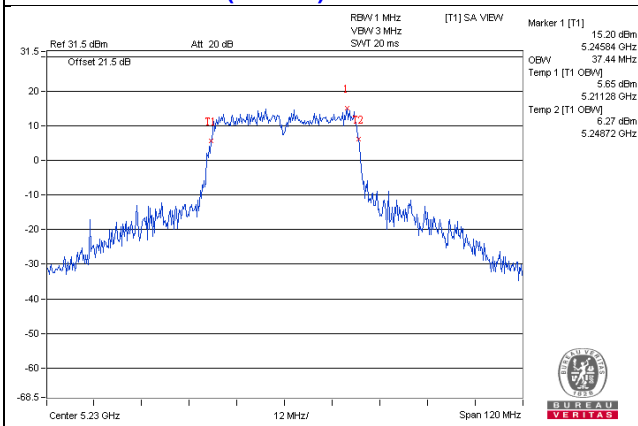

802.11ac (VHT80) / Chain 0 – CH42

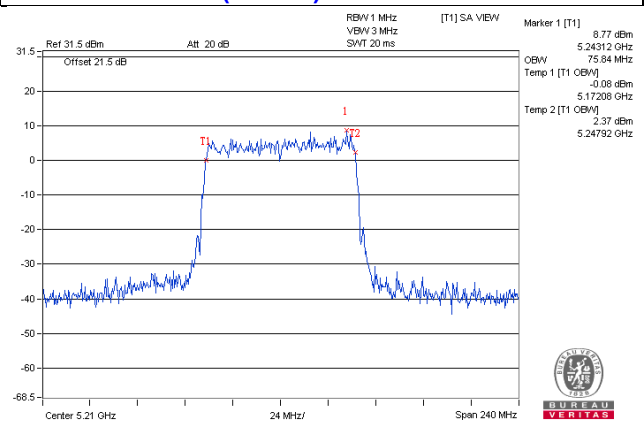

**Spectrum Plot for near by DFS band  
(DFS is required, if 99% OCP straddle into U-NII-2A band)**

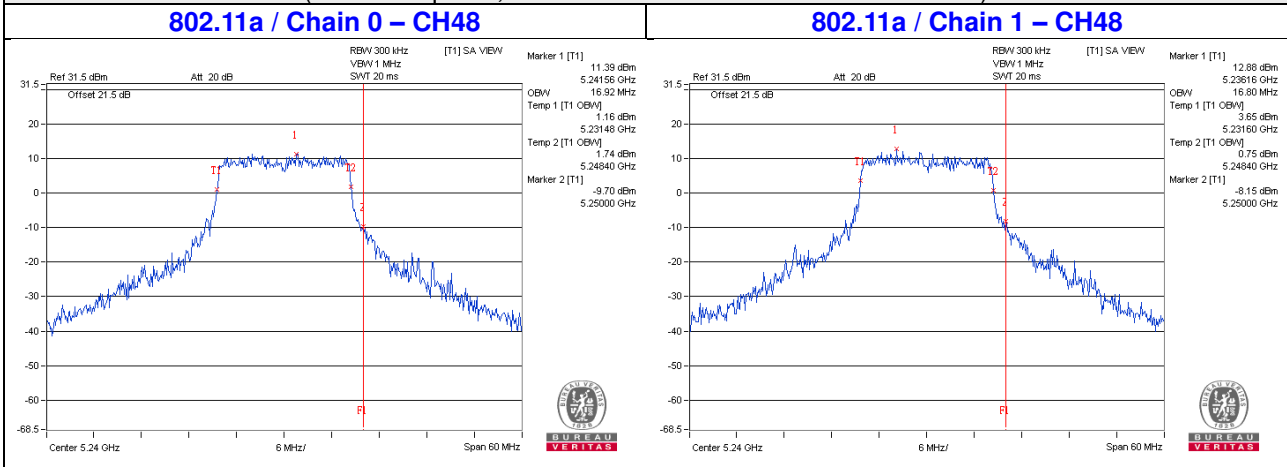

**Spectrum Plot for near by DFS band  
(DFS is required, if 99% OCP straddle into U-NII-2A band)**

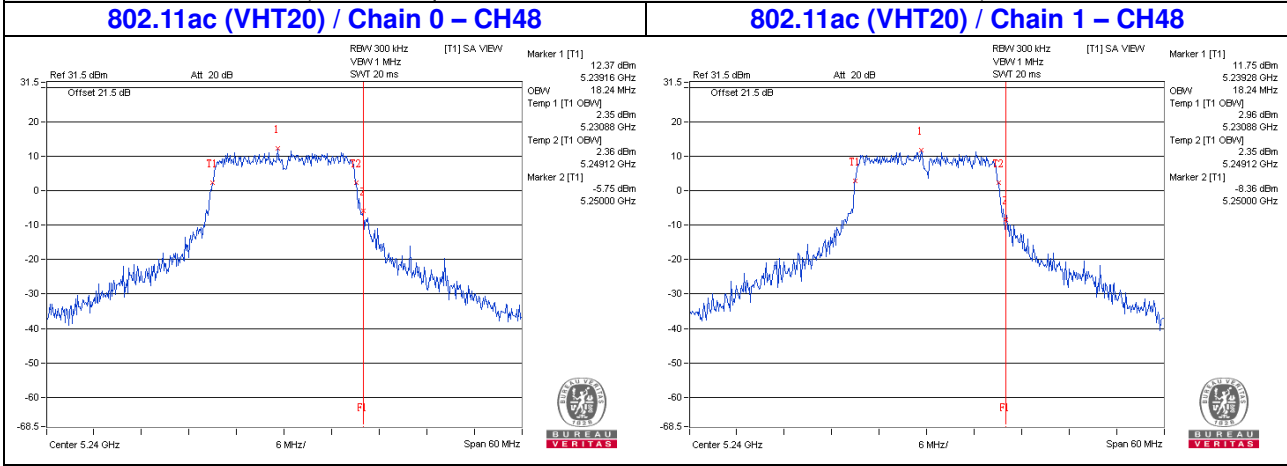



**Spectrum Plot for near by DFS band  
(DFS is required, if 99% OCP straddle into U-NII-2A band)**

**802.11ac (VHT40) / Chain 0 – CH46**

**802.11ac (VHT40) / Chain 1 – CH46**

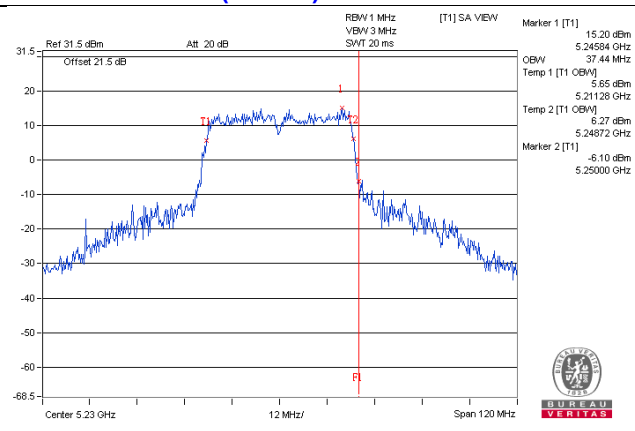
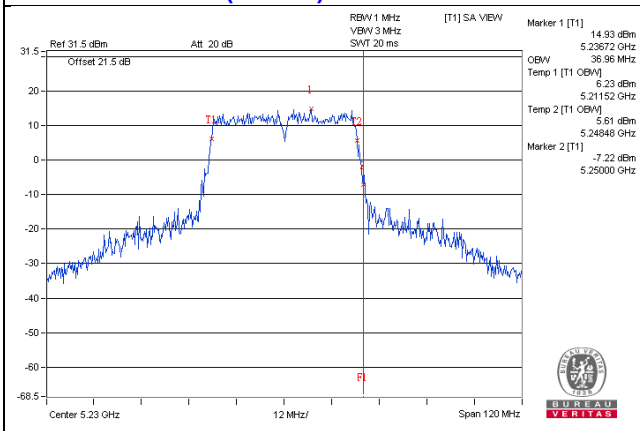

**Spectrum Plot for near by DFS band  
(DFS is required, if 99% OCP straddle into U-NII-2A band)**

**802.11ac (VHT80) / Chain 0 – CH42**

**802.11ac (VHT80) / Chain 1 – CH42**

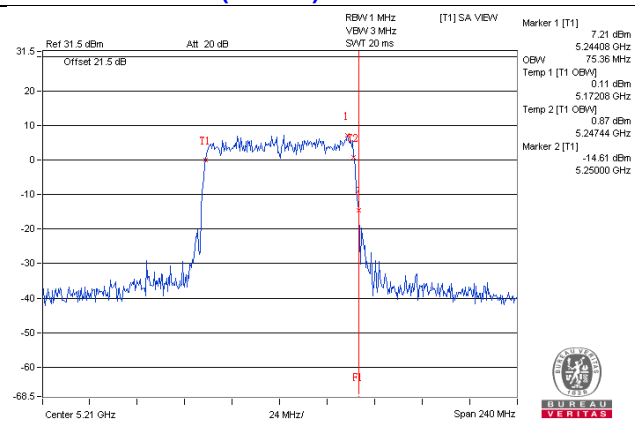
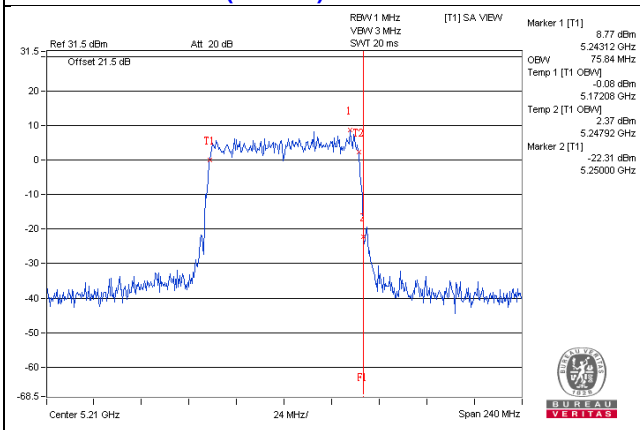

## 4.5 Peak Power Spectral Density Measurement

### 4.5.1 Limits of Peak Power Spectral Density Measurement

Operation Band	EUT Category		Limit
U-NII-1		Outdoor Access Point	17dBm/ MHz
		Fixed point-to-point Access Point	
		Indoor Access Point	
	√	Mobile and Portable client device	11dBm/ MHz
U-NII-2A		√	11dBm/ MHz
U-NII-2C		√	11dBm/ MHz
U-NII-3		√	30dBm/ 500kHz

Note: This device can support different category application which switched to master mode or client mode by software.

### 4.5.2 Test Setup

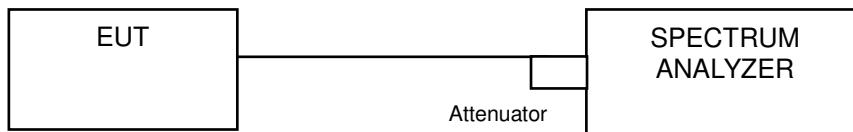

### 4.5.3 Test Instruments

Refer to section 4.1.2 to get information of above instrument.

#### 4.5.4 Test Procedure

##### **For U-NII-1, U-NII-2A, U-NII-2C band:**

Using method SA-1

1. Set span to encompass the entire emission bandwidth (EBW) of the signal.
2. Set RBW = 1 MHz, Set VBW  $\geq$  3 MHz, Detector = RMS
3. Sweep time = auto, trigger set to "free run".
4. Trace average at least 100 traces in power averaging mode.
5. Record the max value

##### **For U-NII-3:**

1. Set span to encompass the entire emission bandwidth (EBW) of the signal.
2. Set RBW = 300 kHz, Set VBW  $\geq$  1 MHz, Detector = RMS
3. Use the peak marker function to determine the maximum power level in any 300 kHz band segment within the fundamental EBW.
4. Scale the observed power level to an equivalent value in 500 kHz by adjusting (reducing) the measured power by a bandwidth correction factor (BWCF) where  $BWCF = 10\log(500 \text{ kHz}/300\text{kHz})$
5. Sweep time = auto, trigger set to "free run".
6. Trace average at least 100 traces in power averaging mode.
7. Record the max value

#### 4.5.5 Deviation from Test Standard

No deviation.

#### 4.5.6 EUT Operating Condition

Same as Item 4.3.6.

#### 4.5.7 Test Results

#### For U-NII-1, U-NII 2A, U-NII-2C

#### 802.11a

Chan.	Chan. Freq. (MHz)	PSD (dBm/MHz)		Total Power Density (dBm/MHz)	MAX. Limit (dBm/MHz)	Pass / Fail
		Chain 0	Chain 1			
36	5180	7.04	7.48	10.28	11.00	Pass
40	5200	6.52	6.73	9.64	11.00	Pass
48	5240	7.54	7.61	10.59	11.00	Pass
52	5260	7.38	7.46	10.43	11.00	Pass
60	5300	6.88	7.41	10.16	11.00	Pass
64	5320	7.15	7.36	10.27	11.00	Pass
100	5500	7.17	7.22	10.21	11.00	Pass
116	5580	7.36	7.84	10.62	11.00	Pass
140	5700	6.20	6.52	9.37	11.00	Pass
144 (UNII-2C Band)	5720	6.75	7.24	10.01	11.00	Pass

- Note:**
- Method a) of power density measurement of KDB 662911 is using for calculating total power density. Total power density is summing entire spectra across corresponding frequency bins on the various outputs by computer.
  - Directional gain = 4.93dBi < 6dBi, so the power density limit shall not be reduced.

**802.11ac (VHT20)**

Chan.	Chan. Freq. (MHz)	PSD (dBm/MHz)		Total Power Density (dBm/MHz)	MAX. Limit (dBm/MHz)	Pass / Fail
		Chain 0	Chain 1			
36	5180	7.09	7.48	10.30	11.00	Pass
40	5200	7.20	7.11	10.17	11.00	Pass
48	5240	7.37	7.47	10.43	11.00	Pass
52	5260	7.22	7.45	10.35	11.00	Pass
60	5300	7.10	7.40	10.26	11.00	Pass
64	5320	6.75	7.28	10.03	11.00	Pass
100	5500	6.74	7.82	10.32	11.00	Pass
116	5580	7.17	7.74	10.47	11.00	Pass
140	5700	5.84	6.58	9.24	11.00	Pass
144 (UNII-2C Band)	5720	7.03	7.29	10.17	11.00	Pass

- Note:** 1. Method a) of power density measurement of KDB 662911 is using for calculating total power density. Total power density is summing entire spectra across corresponding frequency bins on the various outputs by computer.
2. Directional gain = 4.93dBi < 6dBi, so the power density limit shall not be reduced.

### 802.11ac (VHT40)

Chan.	Chan. Freq. (MHz)	PSD (dBm/MHz)		Total Power Density (dBm/MHz)	MAX. Limit (dBm/MHz)	Pass / Fail
		Chain 0	Chain 1			
38	5190	0.80	1.24	4.04	11.00	Pass
46	5230	4.73	5.26	8.01	11.00	Pass
54	5270	4.28	5.12	7.73	11.00	Pass
62	5310	1.52	1.83	4.69	11.00	Pass
102	5510	1.50	2.20	4.87	11.00	Pass
110	5550	4.71	4.87	7.80	11.00	Pass
134	5670	3.80	4.45	7.15	11.00	Pass
142 (UNII-2C Band)	5710	3.68	3.76	6.73	11.00	Pass

**Note:** 1. Method a) of power density measurement of KDB 662911 is using for calculating total power density. Total power density is summing entire spectra across corresponding frequency bins on the various outputs by computer.

2. Directional gain = 4.93dBi < 6dBi, so the power density limit shall not be reduced.

### 802.11ac (VHT80)

Chan.	Chan. Freq. (MHz)	PSD (dBm/MHz)		Total Power Density (dBm/MHz)	MAX. Limit (dBm/MHz)	Pass / Fail
		Chain 0	Chain 1			
42	5210	-1.72	-1.37	1.47	11.00	Pass
58	5290	-0.85	-0.22	2.49	11.00	Pass
106	5530	-0.54	-0.55	2.47	11.00	Pass
122	5610	1.91	2.19	5.06	11.00	Pass
138 (UNII-2C Band)	5690	1.30	1.45	4.39	11.00	Pass

**Note:** 1. Method a) of power density measurement of KDB 662911 is using for calculating total power density. Total power density is summing entire spectra across corresponding frequency bins on the various outputs by computer.

2. Directional gain = 4.93dBi < 6dBi, so the power density limit shall not be reduced.

Spectrum Plot of Worst Value

802.11a / Chain 1 – CH116

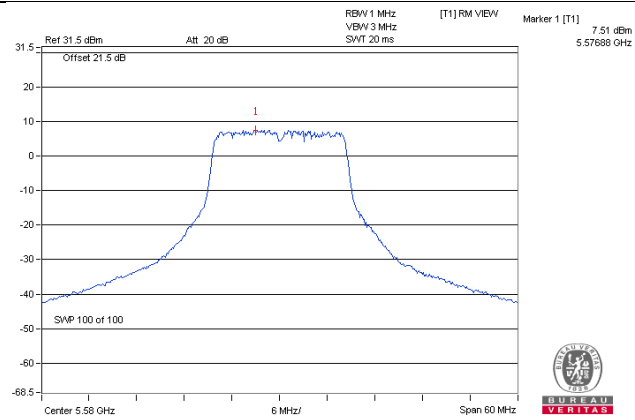

802.11ac (VHT20) / Chain 1 – CH100

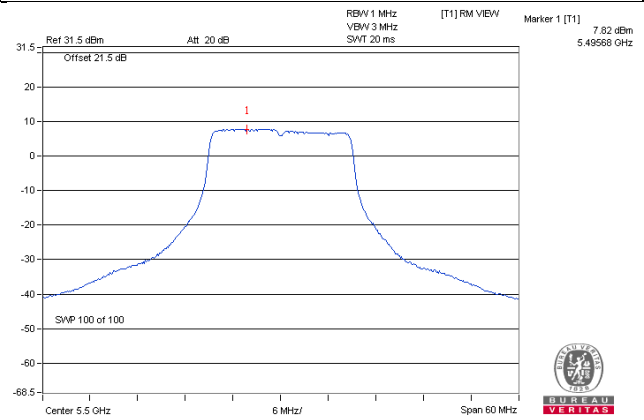

802.11ac (VHT40) / Chain 1 – CH46

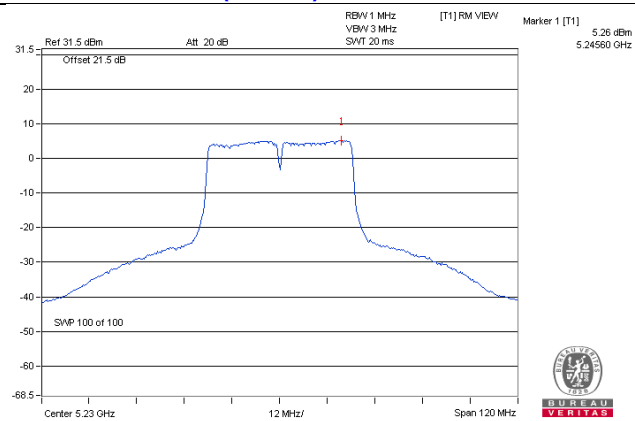

802.11ac (VHT80) / Chain 1 – CH122

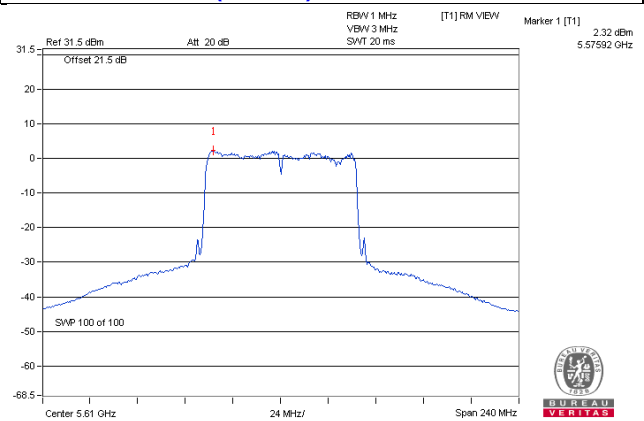

**For U-NII-3:  
802.11a**

TX chain	Channel	Freq. (MHz)	PSD (dBm/300kHz)	PSD (dBm/500kHz)	10 log (N=2) dB	Total PSD (dBm/500kHz)	Limit (dBm/500kHz)	Pass /Fail
0	144 (UNII-3 Band)	5720	-1.04	1.18	3.01	4.19	30.00	Pass
	149	5745	-0.15	2.07	3.01	5.08	30.00	Pass
	157	5785	-0.47	1.75	3.01	4.76	30.00	Pass
	165	5825	-0.86	1.36	3.01	4.37	30.00	Pass
1	144 (UNII-3 Band)	5720	-2.28	-0.06	3.01	2.95	30.00	Pass
	149	5745	-0.54	1.68	3.01	4.69	30.00	Pass
	157	5785	-0.71	1.51	3.01	4.52	30.00	Pass
	165	5825	-1.20	1.02	3.01	4.03	30.00	Pass

Note: 1. For U-NII-3 band: Directional gain = 4.88dBi < 6dBi, so the power density limit shall not be reduced.

**802.11ac (VHT20)**

TX chain	Channel	Freq. (MHz)	PSD (dBm/300kHz)	PSD (dBm/500kHz)	10 log (N=2) dB	Total PSD (dBm/500kHz)	Limit (dBm/500kHz)	Pass /Fail
0	144 (UNII-3 Band)	5720	-1.03	1.19	3.01	4.20	30.00	Pass
	149	5745	-0.28	1.94	3.01	4.95	30.00	Pass
	157	5785	-0.34	1.88	3.01	4.89	30.00	Pass
	165	5825	-0.96	1.26	3.01	4.27	30.00	Pass
1	144 (UNII-3 Band)	5720	-1.61	0.61	3.01	3.62	30.00	Pass
	149	5745	-0.18	2.04	3.01	5.05	30.00	Pass
	157	5785	-0.67	1.55	3.01	4.56	30.00	Pass
	165	5825	-1.14	1.08	3.01	4.09	30.00	Pass

Note: 1. For U-NII-3 band: Directional gain = 4.88dBi < 6dBi, so the power density limit shall not be reduced.



### 802.11ac (VHT40)

TX chain	Channel	Freq. (MHz)	PSD (dBm/300kHz)	PSD (dBm/500kHz)	10 log (N=2) dB	Total PSD (dBm/500kHz)	Limit (dBm/500kHz)	Pass /Fail
0	142 (UNII-3 Band)	5710	-4.53	-2.31	3.01	0.70	30.00	Pass
	151	5755	-3.23	-1.01	3.01	2.00	30.00	Pass
	159	5795	-3.94	-1.72	3.01	1.29	30.00	Pass
1	142 (UNII-3 Band)	5710	-4.51	-2.29	3.01	0.72	30.00	Pass
	151	5755	-2.93	-0.71	3.01	2.30	30.00	Pass
	159	5795	-3.86	-1.64	3.01	1.37	30.00	Pass

Note: 1. For U-NII-3 band: Directional gain = 4.88dBi < 6dBi, so the power density limit shall not be reduced.

### 802.11ac (VHT80)

TX chain	Channel	Freq. (MHz)	PSD (dBm/300kHz)	PSD (dBm/500kHz)	10 log (N=2) dB	Total PSD (dBm/500kHz)	Limit (dBm/500kHz)	Pass /Fail
0	138 (UNII-3 Band)	5690	-7.23	-5.01	3.01	-2.00	30.00	Pass
	155	5775	-6.81	-4.59	3.01	-1.58	30.00	Pass
1	138 (UNII-3 Band)	5690	-7.51	-5.29	3.01	-2.28	30.00	Pass
	155	5775	-8.61	-6.39	3.01	-3.38	30.00	Pass

Note: 1. For U-NII-3 band: Directional gain = 4.88dBi < 6dBi, so the power density limit shall not be reduced.

Spectrum Plot of Worst Value

802.11a – Chain 0: CH 149

802.11ac (VHT20) – Chain 1: CH 149

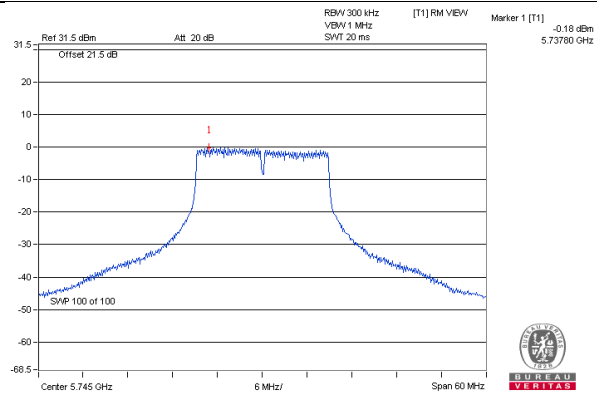
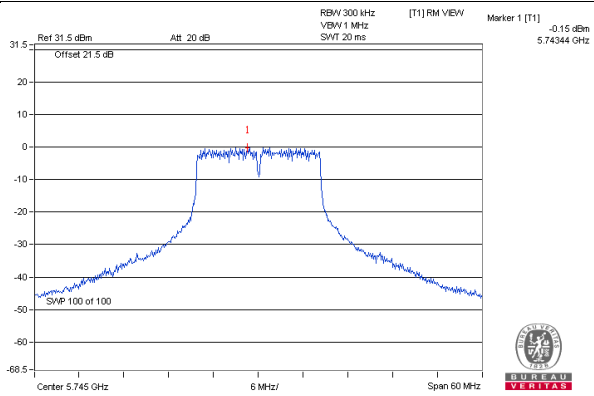

802.11ac (VHT40) – Chain 1: CH 151

802.11ac (VHT80) – Chain 0: CH 155

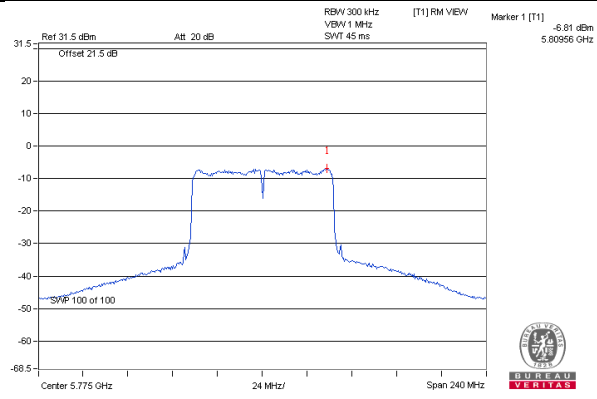
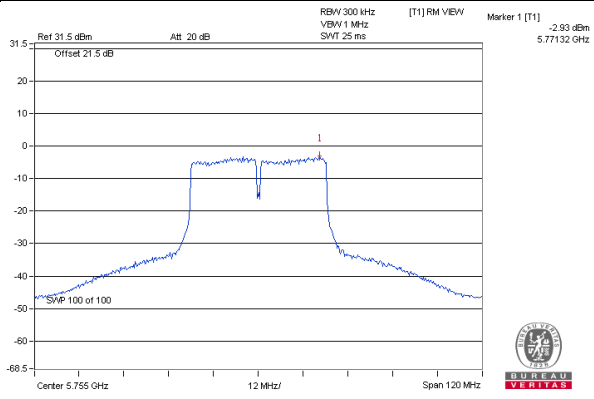

## 4.6 Frequency Stability Measurement

### 4.6.1 Limits of Frequency Stability Measurement

The frequency of the carrier signal shall be maintained within band of operation

### 4.6.2 Test Setup

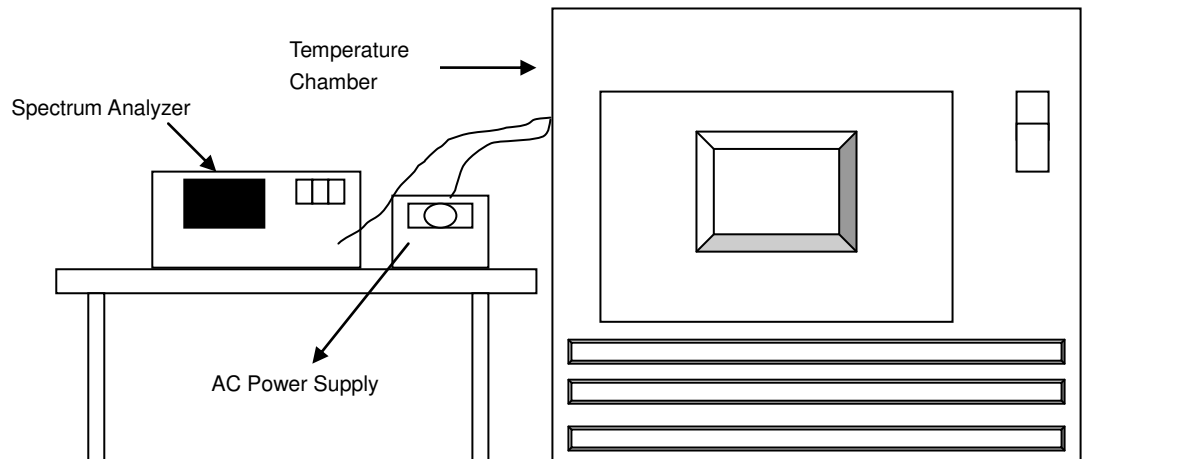

### 4.6.3 Test Instruments

Refer to section 4.1.2 to get information of above instrument.

### 4.6.4 Test Procedure

- The EUT was placed inside the environmental test chamber and powered by nominal AC voltage.
- Turn the EUT on and couple its output to a spectrum analyzer.
- Turn the EUT off and set the chamber to the highest temperature specified.
- Allow sufficient time (approximately 30 min) for the temperature of the chamber to stabilize, turn the EUT on and measure the operating frequency after 2, 5, and 10 Minutes.
- Repeat step 2 and 3 with the temperature chamber set to the lowest temperature.
- The test chamber was allowed to stabilize at +20 degree C for a minimum of 30 Minutes. The supply voltage was then adjusted on the EUT from 85% to 115% and the frequency record.

### 4.6.5 Deviation from Test Standard

No deviation.

### 4.6.6 EUT Operating Condition

Set the EUT transmit at un-modulation mode to test frequency stability.

#### 4.6.7 Test Results

<b>Frequency Stability Versus Temp.</b>									
<b>Operating Frequency: 5180 MHz</b>									
<b>TEMP.</b> <b>(°C)</b>	<b>Power</b> <b>Supply</b> <b>(Vac)</b>	<b>0 Minute</b>		<b>2 Minute</b>		<b>5 Minute</b>		<b>10 Minute</b>	
		<b>Measured</b> <b>Frequency</b> <b>(MHz)</b>	<b>Pass/Fail</b>	<b>Measured</b> <b>Frequency</b> <b>(MHz)</b>	<b>Pass/Fail</b>	<b>Measured</b> <b>Frequency</b> <b>(MHz)</b>	<b>Pass/Fail</b>	<b>Measured</b> <b>Frequency</b> <b>(MHz)</b>	<b>Pass/Fail</b>
50	120	5180.0115	PASS	5180.0129	PASS	5180.0131	PASS	5180.0132	Pass
40	120	5179.9881	PASS	5179.9863	PASS	5179.9882	PASS	5179.9879	Pass
30	120	5180.0094	PASS	5180.0098	PASS	5180.01	PASS	5180.0113	Pass
20	120	5179.9979	PASS	5179.9998	PASS	5179.9965	PASS	5179.9965	Pass
10	120	5180.0005	PASS	5179.9983	PASS	5179.9967	PASS	5179.9989	Pass
0	120	5180.0126	PASS	5180.0164	PASS	5180.0138	PASS	5180.0158	Pass
-10	120	5179.9878	PASS	5179.9876	PASS	5179.9867	PASS	5179.99	Pass
-20	120	5179.9771	PASS	5179.9811	PASS	5179.9801	PASS	5179.9784	Pass
-30	120	5180.0096	PASS	5180.0097	PASS	5180.0112	PASS	5180.0096	Pass

<b>Frequency Stability Versus Voltage</b>									
<b>Operating Frequency: 5180 MHz</b>									
<b>TEMP.</b> <b>(°C)</b>	<b>Power</b> <b>Supply</b> <b>(Vac)</b>	<b>0 Minute</b>		<b>2 Minute</b>		<b>5 Minute</b>		<b>10 Minute</b>	
		<b>Measured</b> <b>Frequency</b> <b>(MHz)</b>	<b>Pass/Fail</b>	<b>Measured</b> <b>Frequency</b> <b>(MHz)</b>	<b>Pass/Fail</b>	<b>Measured</b> <b>Frequency</b> <b>(MHz)</b>	<b>Pass/Fail</b>	<b>Measured</b> <b>Frequency</b> <b>(MHz)</b>	<b>Pass/Fail</b>
20	138	5179.9975	PASS	5180.0002	PASS	5179.9956	PASS	5179.9964	Pass
	120	5179.9979	PASS	5179.9998	PASS	5179.9965	PASS	5179.9965	Pass
	102	5179.9978	PASS	5180	PASS	5179.996	PASS	5179.9957	Pass

## 4.7 6dB Bandwidth Measurement

### 4.7.1 Limits of 6dB Bandwidth Measurement

The minimum of 6dB Bandwidth Measurement is 0.5MHz.

### 4.7.2 Test Setup

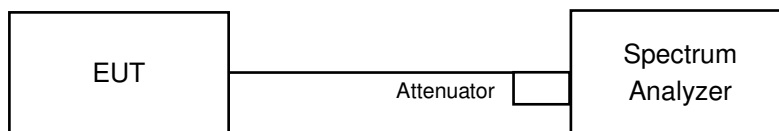

### 4.7.3 Test Instruments

Refer to section 4.1.2 to get information of above instrument.

### 4.7.4 Test Procedure

#### MEASUREMENT PROCEDURE REF

- a. Set resolution bandwidth (RBW) = 100kHz
- b. Set the video bandwidth (VBW)  $\geq 3 \times$  RBW, Detector = Peak.
- c. Trace mode = max hold.
- d. Sweep = auto couple.
- e. Measure the maximum width of the emission that is constrained by the frequencies associated with the two amplitude points (upper and lower) that are attenuated by 6 dB relative to the maximum level measured in the fundamental emission

### 4.7.5 Deviation from Test Standard

No deviation.

### 4.7.6 EUT Operating Condition

The software provided by client to enable the EUT under transmission condition continuously at lowest, middle and highest channel frequencies individually.

#### 4.7.7 Test Results

##### 802.11a

Channel	Frequency (MHz)	6dB Bandwidth (MHz)		Minimum Limit (MHz)	Pass / Fail
		Chain 0	Chain 1		
*144 (UNII-3 Band)	5720	3.19	3.17	0.5	Pass
149	5745	16.42	16.41	0.5	Pass
157	5785	16.42	16.40	0.5	Pass
165	5825	16.43	16.42	0.5	Pass

Note: \*The 6dB bandwidth above 5725MHz = Marker 1 + Delta 2 - 5725MHz

##### 802.11ac (VHT20)

Channel	Frequency (MHz)	6dB Bandwidth (MHz)		Minimum Limit (MHz)	Pass / Fail
		Chain 0	Chain 1		
*144 (UNII-3 Band)	5720	3.81	3.82	0.5	Pass
149	5745	17.67	17.65	0.5	Pass
157	5785	17.67	17.66	0.5	Pass
165	5825	17.64	17.67	0.5	Pass

Note: \*The 6dB bandwidth above 5725MHz = Marker 1 + Delta 2 - 5725MHz

##### 802.11ac (VHT40)

Channel	Frequency (MHz)	6dB Bandwidth (MHz)		Minimum Limit (MHz)	Pass / Fail
		Chain 0	Chain 1		
*142 (UNII-3 Band)	5710	3.27	3.22	0.5	Pass
151	5755	36.49	36.45	0.5	Pass
159	5795	36.50	36.44	0.5	Pass

Note: \*The 6dB bandwidth above 5725MHz = Marker 1 + Delta 2 - 5725MHz

### 802.11ac (VHT80)

Channel	Frequency (MHz)	6dB Bandwidth (MHz)		Minimum Limit (MHz)	Pass / Fail
		Chain 0	Chain 1		
*138 (UNII-3 Band)	5690	2.73	2.77	0.5	Pass
155	5775	75.59	75.61	0.5	Pass

Note: \*The 6dB bandwidth above 5725MHz = Marker 1 + Delta 2 - 5725MHz

#### Spectrum Plot of Worst Value

802.11a / Chain 1 - CH144 (UNII-3 Band)

802.11ac (VHT20) / Chain 0 - CH144 (UNII-3 Band)

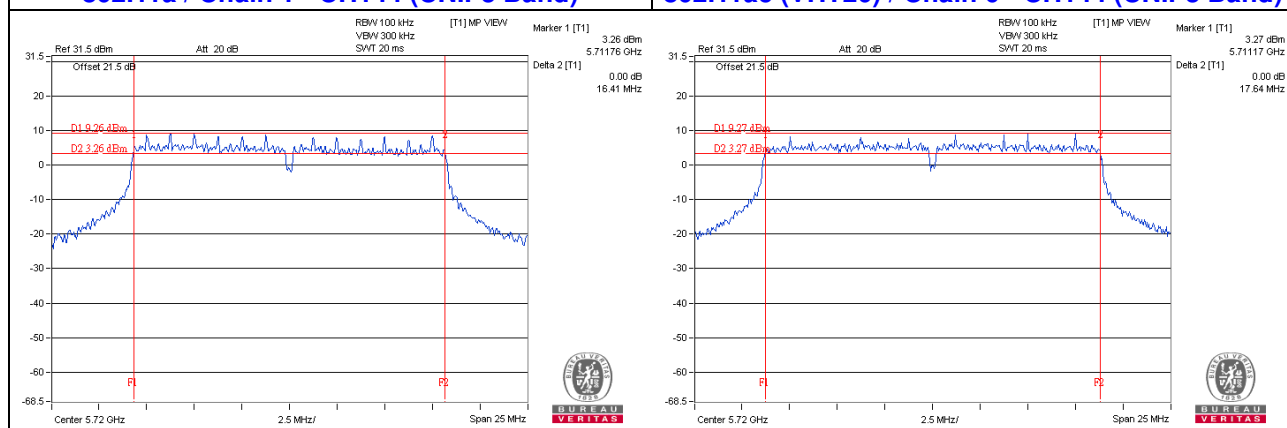

802.11ac (VHT40) / Chain 1 - CH142 (UNII-3 Band)

802.11ac (VHT80) / Chain 0 - CH138 (UNII-3 Band)

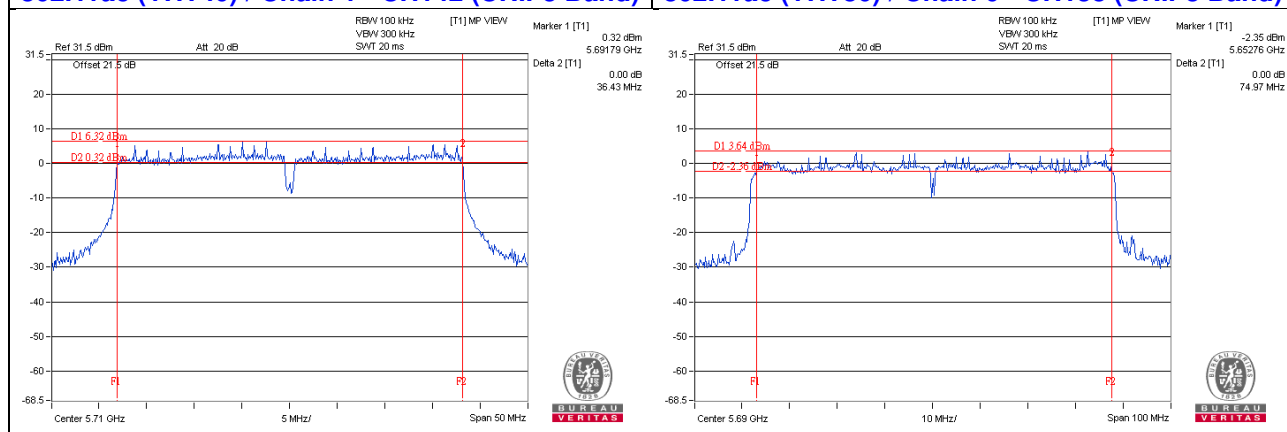

## 5 Pictures of Test Arrangements

Please refer to the attached file (Test Setup Photo).



### Annex A- Radiated Out of Band Emission (OOBE) Measurement (For U-NII-3 band)

802.11a

**CH 149 5745 MHz**

**Horizontal**

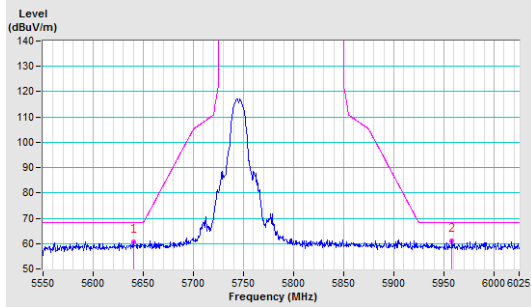

**Vertical**

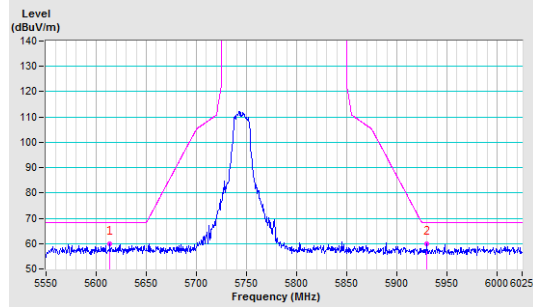

**CH 157 5785 MHz**

**Horizontal**

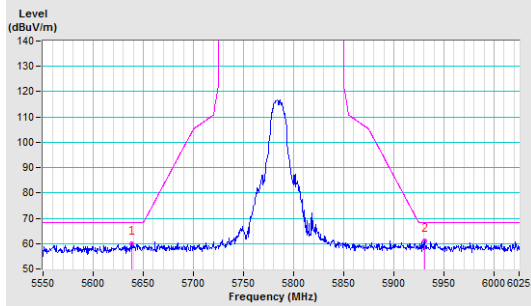

**Vertical**

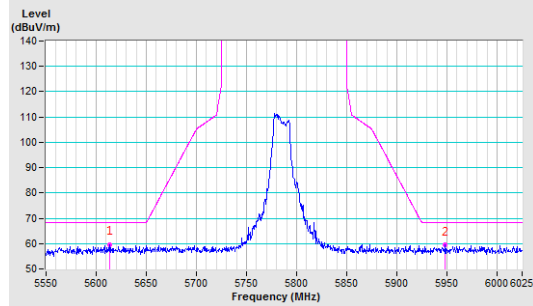

**CH 165 5825 MHz**

**Horizontal**

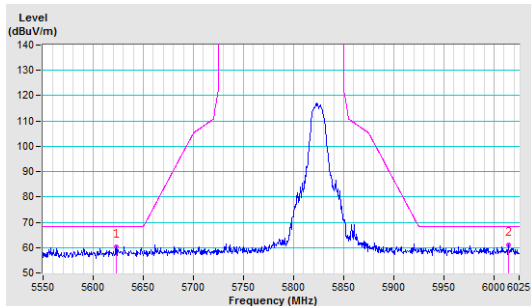

**Vertical**

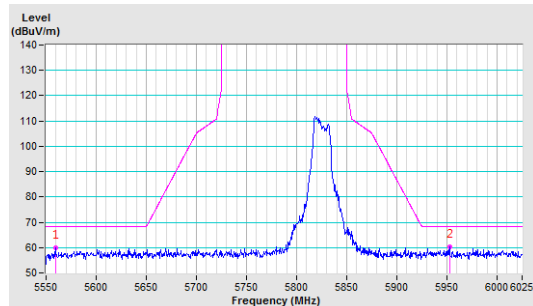

802.11ac (VHT20)

CH 149 5745 MHz

Horizontal

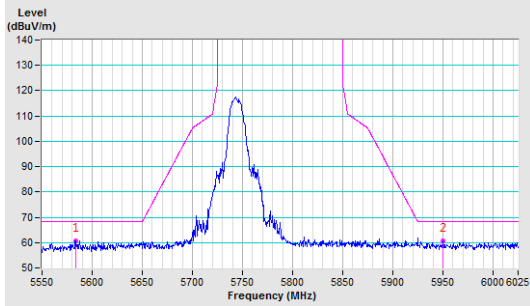

Vertical

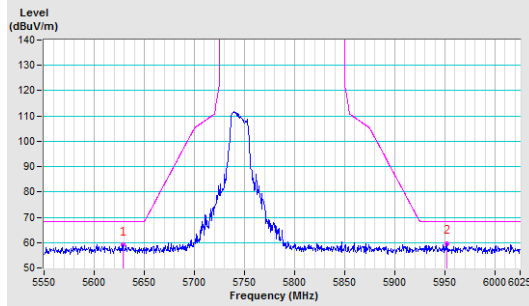

CH 157 5785 MHz

Horizontal

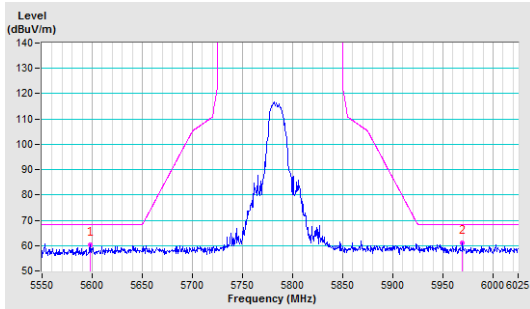

Vertical

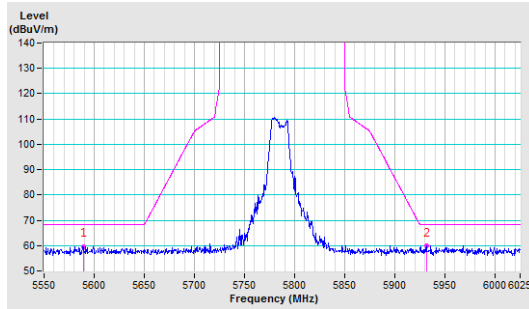

CH 165 5825 MHz

Horizontal

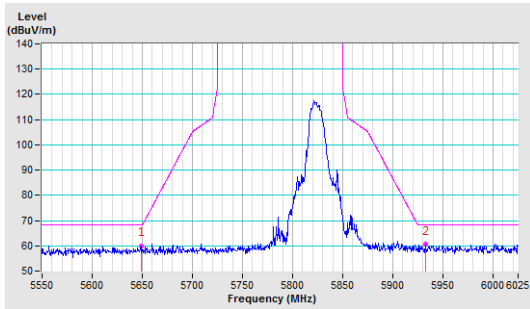

Vertical

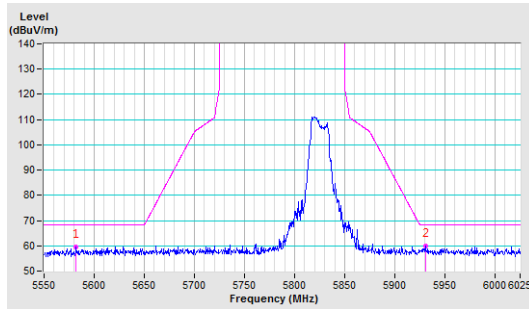

### 802.11ac (VHT40)

**CH 151 5755 MHz**

**Horizontal**

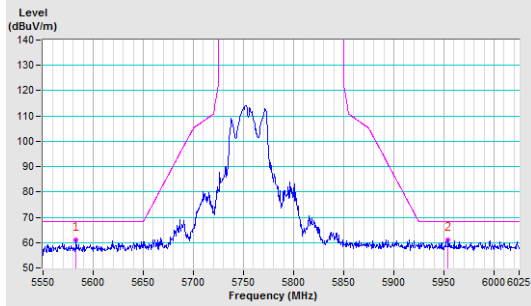

**Vertical**

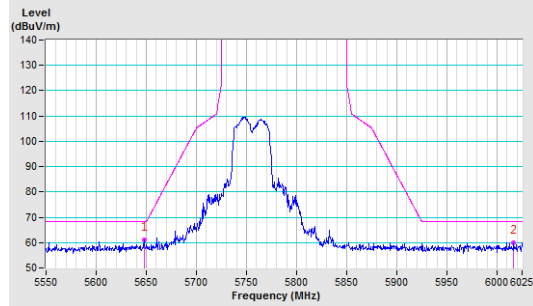

**CH 159 5795 MHz**

**Horizontal**

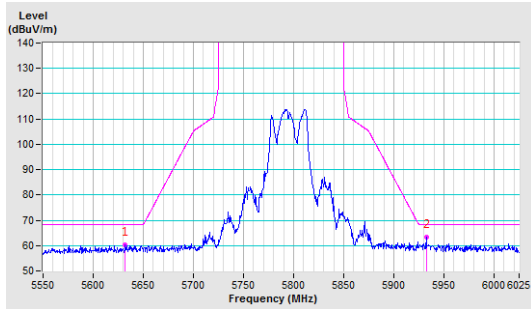

**Vertical**

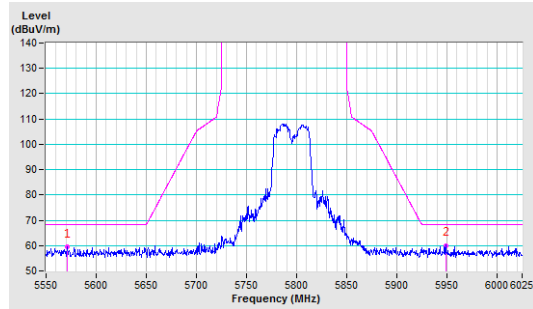

### 802.11ac (VHT80)

**CH 155 5775 MHz**

**Horizontal**

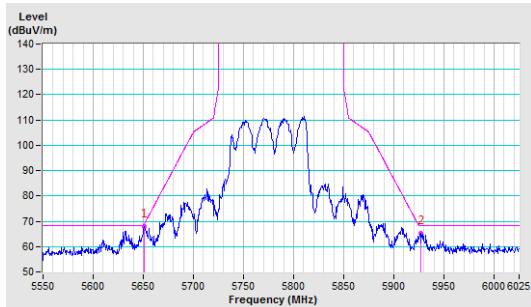

**Vertical**

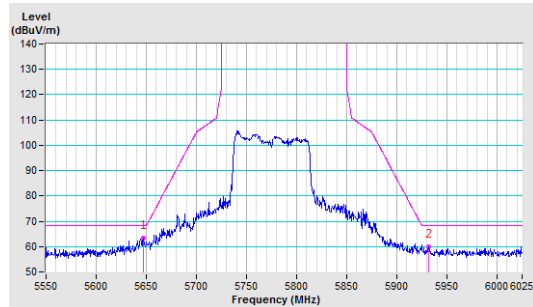

## Appendix – Information on the Testing Laboratories

We, Bureau Veritas Consumer Products Services (H.K.) Ltd., Taoyuan Branch, were founded in 1988 to provide our best service in EMC, Radio, Telecom and Safety consultation. Our laboratories are accredited and approved according to ISO/IEC 17025.

If you have any comments, please feel free to contact us at the following:

**Linko EMC/RF Lab**

Tel: 886-2-26052180

Fax: 886-2-26051924

**Hsin Chu EMC/RF/Telecom Lab**

Tel: 886-3-6668565

Fax: 886-3-6668323

**Hwa Ya EMC/RF/Safety Lab**

Tel: 886-3-3183232

Fax: 886-3-3270892

**Email:** [service.adt@tw.bureauveritas.com](mailto:service.adt@tw.bureauveritas.com)

**Web Site:** [www.bureauveritas-adt.com](http://www.bureauveritas-adt.com)

The address and road map of all our labs can be found in our web site also.

--- END ---