

FCC Test Report (DFS Band)

Report No.: RF180625E05A-1

FCC ID: 2ABTEG1500

Test Model: Fios-G1500

Received Date: July 30, 2018

Test Date: Aug. 09 to 27, 2018

Issued Date: Nov. 27, 2018

Applicant: Verizon Online LLC

Address: 1300 I Street NW, Room 400W, Washington, District of Columbia, 20005
United State

Issued By: Bureau Veritas Consumer Products Services (H.K.) Ltd., Taoyuan Branch
Hsin Chu Laboratory

Lab Address: E-2, No.1, Li Hsin 1st Road, Hsinchu Science Park, Hsinchu City 300,
Taiwan R.O.C.

Test Location: E-2, No.1, Li Hsin 1st Road, Hsinchu Science Park, Hsinchu City 300,
Taiwan R.O.C.

**FCC Registration /
Designation Number:** 723255 / TW2022



This report is for your exclusive use. Any copying or replication of this report to or for any other person or entity, or use of our name or trademark, is permitted only with our prior written permission. This report sets forth our findings solely with respect to the test samples identified herein. The results set forth in this report are not indicative or representative of the quality or characteristics of the lot from which a test sample was taken or any similar or identical product unless specifically and expressly noted. Our report includes all of the tests requested by you and the results thereof based upon the information that you provided to us. You have 60 days from date of issuance of this report to notify us of any material error or omission caused by our negligence, provided, however, that such notice shall be in writing and shall specifically address the issue you wish to raise. A failure to raise such issue within the prescribed time shall constitute your unqualified acceptance of the completeness of this report, the tests conducted and the correctness of the report contents. Unless specific mention, the uncertainty of measurement has been explicitly taken into account to declare the compliance or non-compliance to the specification. The report must not be used by the client to claim product certification, approval, or endorsement by TAF or any government agencies.

Table of Contents

Release Control Record	4
1 Certificate of Conformity	5
2 Summary of Test Results	6
2.1 Measurement Uncertainty	6
2.2 Modification Record	6
3 General Information	7
3.1 General Description of EUT (DFS Band)	7
3.2 Description of Test Modes	10
3.2.1 Test Mode Applicability and Tested Channel Detail	11
3.3 Duty Cycle of Test Signal	13
3.4 Description of Support Units	14
3.4.1 Configuration of System under Test	15
3.5 General Description of Applied Standard	16
4 Test Types and Results	17
4.1 Radiated Emission and Bandedge Measurement	17
4.1.1 Limits of Radiated Emission and Bandedge Measurement	17
4.1.2 Test Instruments	18
4.1.3 Test Procedure	19
4.1.4 Deviation from Test Standard	19
4.1.5 Test Setup	20
4.1.6 EUT Operating Condition	21
4.1.7 Test Results	22
4.2 Conducted Emission Measurement	48
4.2.1 Limits of Conducted Emission Measurement	48
4.2.2 Test Instruments	48
4.2.3 Test Procedure	49
4.2.4 Deviation from Test Standard	49
4.2.5 Test Setup	49
4.2.6 EUT Operating Condition	49
4.2.7 Test Results (Mode 1)	50
4.2.8 Test Results (Mode 2)	52
4.3 Transmit Power Measurement	54
4.3.1 Limits of Transmit Power Measurement	54
4.3.2 Test Setup	55
4.3.3 Test Instruments	55
4.3.4 Test Procedure	55
4.3.5 Deviation from Test Standard	56
4.3.6 EUT Operating Condition	56
4.3.7 Test Results	57
4.4 Occupied Bandwidth Measurement	75
4.4.1 Test Setup	75
4.4.2 Test Instruments	75
4.4.3 Test Procedure	75
4.4.4 Test Results	76
4.5 Peak Power Spectral Density Measurement	79
4.5.1 Limits of Peak Power Spectral Density Measurement	79
4.5.2 Test Setup	79
4.5.3 Test Instruments	79
4.5.4 Test Procedure	79
4.5.5 Deviation from Test Standard	79
4.5.6 EUT Operating Condition	79
4.5.7 Test Results	80
4.6 Frequency Stability Measurement	86

4.6.1	Limits of Frequency Stability Measurement	86
4.6.2	Test Setup.....	86
4.6.3	Test Instruments	86
4.6.4	Test Procedure	86
4.6.5	Deviation from Test Standard	86
4.6.6	EUT Operating Condition	86
4.6.7	Test Results	87
4.7	6dB Bandwidth Measurement	88
4.7.1	Limits of 6dB Bandwidth Measurement.....	88
4.7.2	Test Setup.....	88
4.7.3	Test Instruments	88
4.7.4	Test Procedure	88
4.7.5	Deviation from Test Standard	88
4.7.6	EUT Operating Condition	88
4.7.7	Test Results	89
5	Pictures of Test Arrangements.....	91
	Appendix – Information on the Testing Laboratories	92

Release Control Record

Issue No.	Description	Date Issued
RF180625E05A-1	Original release.	Nov. 27, 2018

1 Certificate of Conformity

Product: Fios-G1500

Brand: Verizon

Test Model: Fios-G1500

Sample Status: ENGINEERING SAMPLE

Applicant: Verizon Online LLC

Test Date: Aug. 09 to 27, 2018

Standard: 47 CFR FCC Part 15, Subpart E (Section 15.407)
ANSI C63.10: 2013

The above equipment has been tested by **Bureau Veritas Consumer Products Services (H.K.) Ltd., Taoyuan Branch**, and found compliance with the requirement of the above standards. The test record, data evaluation & Equipment Under Test (EUT) configurations represented herein are true and accurate accounts of the measurements of the sample's EMC characteristics under the conditions specified in this report.

Prepared by :

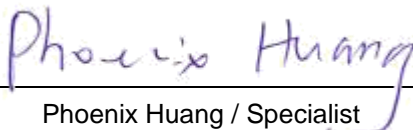
Phoenix Huang / Specialist

Date:

Nov. 27, 2018

Approved by :

May Chen / Manager

Date:

Nov. 27, 2018

2 Summary of Test Results

47 CFR FCC Part 15, Subpart E (Section 15.407)			
FCC Clause	Test Item	Result	Remarks
15.407(b)(6)	AC Power Conducted Emissions	Pass	Meet the requirement of limit. Minimum passing margin is -3.90dB at 0.36484MHz.
15.407(b) (1/2/3/4(i/ii)/6)	Radiated Emissions & Band Edge Measurement	Pass	Meet the requirement of limit. Minimum passing margin is -0.1dB at 5353.80MHz, 5470.00MHz and 5725.00MHz.
15.407(a)(1/2/3)	Max Average Transmit Power	Pass	Meet the requirement of limit.
---	Occupied Bandwidth Measurement	-	Reference only.
15.407(a)(1/2/3)	Peak Power Spectral Density	Pass	Meet the requirement of limit.
15.407(e)	6dB bandwidth	Pass	Meet the requirement of limit. (U-NII-3 Band only)
15.407(g)	Frequency Stability	Pass	Meet the requirement of limit.
15.203	Antenna Requirement	Pass	Antenna connector is i-pex(MHF) not a standard connector.

2.1 Measurement Uncertainty

Where relevant, the following measurement uncertainty levels have been estimated for tests performed on the EUT as specified in CISPR 16-4-2:

Measurement	Frequency	Expanded Uncertainty (k=2) (±)
Conducted Emissions at mains ports	150kHz ~ 30MHz	1.84 dB
Radiated Emissions up to 1 GHz	30MHz ~ 1GHz	5.53 dB
Radiated Emissions above 1 GHz	1GHz ~ 6GHz	5.08 dB
	6GHz ~ 18GHz	4.98 dB
	18GHz ~ 40GHz	5.19 dB

2.2 Modification Record

There were no modifications required for compliance.

3 General Information

3.1 General Description of EUT (DFS Band)

Product	Fios-G1500
Brand	Verizon
Test Model	Fios-G1500
Status of EUT	ENGINEERING SAMPLE
Power Supply Rating	12Vdc from power adapter
Modulation Type	64QAM, 16QAM, QPSK, BPSK for OFDM 256QAM for OFDM in 11ac mode and VHT (20/40) mode in 2.4GHz
Modulation Technology	DSSS,OFDM
Transfer Rate	802.11a: up to 54Mbps 802.11n: up to 600Mbps 802.11ac: up to 1733.3Mbps
Operating Frequency	5.26GHz ~ 5.32GHz, 5.5GHz ~ 5.72GHz
Number of Channel	802.11a, 802.11n (HT20), 802.11ac (VHT20): 16 802.11n (HT40), 802.11ac (VHT40): 8 802.11ac (VHT80): 4
Output Power	CDD Mode: 5.26 ~ 5.32GHz: 247.878mW 5.5 ~ 5.72GHz: 247.392mW Beamforming Mode: 5.26 ~ 5.32GHz: 247.878mW 5.5 ~ 5.72GHz: 247.392mW SDM Mode: 5.26 ~ 5.32GHz: 247.878mW 5.5 ~ 5.72GHz: 247.392mW
Antenna Type	Refer to Note
Antenna Connector	Refer to Note
Accessory Device	Adapter x 1
Data Cable Supplied	NA

Note:

1. This report is prepared for FCC class II change. The difference compared with the Report No.: RF180625E05-1 as the following:

- ◆ Add DFS band <5.26GHz ~ 5.32GHz, 5.50GHz ~ 5.72GHz>

2. According to above condition, all test items need to be performed. And all data were verified to meet the requirements.

3. There are WLAN and Z-Wave technology used for the EUT. The EUT has below radios as following table:

Radio 1	Radio 2	Radio 3
WLAN (2.4GHz)	WLAN (5GHz)	Z-Wave

4. Simultaneously transmission condition.

Condition	Technology		
1	WLAN 2.4GHz	WLAN 5GHz	Z-Wave

Note: The emission of the simultaneous operation has been evaluated and no non-compliance was found.

5. The USB port of the EUT, it can't connect a WiFi/WWAN dongle and transmit simultaneously.

6. The EUT must be supplied with a power adapter as following table:

No.	Brand	Model No.	Spec.
1	Ktec	KSA20C1200300HU	Input: 100-240Vac, 1A, 50-60Hz Output: 12V, 3A DC output cable: Unshielded, 1.5m
2	LEI	MU36-D120300-A1	Input: 100-240Vac, 1.5A, 50-60Hz Output: 12V, 3A DC output cable: Unshielded, 1.5m

Note: In original report, from the above adapters, the radiated emissions worse case was found in **Adapter No. 2**. Therefore only the test data of the mode was recorded in this report.

7. The antennas provided to the EUT, please refer to the following table:

WLAN Directional gain table			
Frequency range (GHz)	Directional Antenna Gain (dBi)	Antenna Type	Antenna Connector
2.4 ~ 2.4835	2.94	Dipole	i-pex(MHF)
5.15 ~ 5.25	3.56		
5.25 ~ 5.35	3.56		
5.47 ~ 5.725	3.56		
5.725 ~ 5.85	3.56		

Z-Wave antenna spec.

Antenna Net Gain (dBi)	Frequency range (MHz)	Antenna Type	Antenna Connector
1.73	902~928	Dipole	None

Note: More detailed information, please refer to operating description.

8. The EUT incorporates a MIMO function:

2.4GHz Band			
MODULATION MODE	DATA RATE (MCS)	TX & RX CONFIGURATION	
802.11b	1 ~ 11Mbps	3TX	3RX
802.11g	6 ~ 54Mbps	3TX	3RX
802.11n (HT20)	MCS 0~7	3TX	3RX
	MCS 8~15	3TX	3RX
	MCS 16~23	3TX	3RX
802.11n (HT40)	MCS 0~7	3TX	3RX
	MCS 8~15	3TX	3RX
	MCS 16~23	3TX	3RX
VHT20	MCS0~8 Nss=1	3TX	3RX
	MCS0~8 Nss=2	3TX	3RX
	MCS0~9 Nss=3	3TX	3RX
VHT40	MCS0~9 Nss=1	3TX	3RX
	MCS0~9 Nss=2	3TX	3RX
	MCS0~9 Nss=3	3TX	3RX
5GHz Band			
MODULATION MODE	DATA RATE (MCS)	TX & RX CONFIGURATION	
802.11a	6 ~ 54Mbps	4TX	4RX
802.11n (HT20)	MCS 0~7	4TX	4RX
	MCS 8~15	4TX	4RX
	MCS 16~23	4TX	4RX
	MCS 24~31	4TX	4RX
802.11n (HT40)	MCS 0~7	4TX	4RX
	MCS 8~15	4TX	4RX
	MCS 16~23	4TX	4RX
	MCS 24~31	4TX	4RX
802.11ac (VHT20)	MCS0~8 Nss=1	4TX	4RX
	MCS0~8 Nss=2	4TX	4RX
	MCS0~9 Nss=3	4TX	4RX
	MCS0~8 Nss=4	4TX	4RX
802.11ac (VHT40)	MCS0~9 Nss=1	4TX	4RX
	MCS0~9 Nss=2	4TX	4RX
	MCS0~9 Nss=3	4TX	4RX
	MCS0~9 Nss=4	4TX	4RX
802.11ac (VHT80)	MCS0~9 Nss=1	4TX	4RX
	MCS0~9 Nss=2	4TX	4RX
	MCS0~9 Nss=3	4TX	4RX
	MCS0~9 Nss=4	4TX	4RX

Note:

- All of modulation mode support beamforming function except 2.4GHz & 802.11a modulation mode.
- The EUT support Beamforming and CDD mode, therefore both mode were investigated and the worst case scenario was identified. The worst case data were presented in test report.
- The modulation and bandwidth are similar for 802.11n mode for 20MHz (40MHz) and 802.11ac mode for 20MHz (40MHz), therefore investigated worst case to representative mode in test report. (Final test mode refer section 3.2.1)

9. The above EUT information is declared by manufacturer and for more detailed features description, please refers to the manufacturer's specifications or user's manual.

3.2 Description of Test Modes

FOR 5260 ~ 5320MHz

4 channels are provided for 802.11a, 802.11n (HT20), 802.11ac (VHT20):

Channel	Frequency	Channel	Frequency
52	5260 MHz	60	5300 MHz
56	5280 MHz	64	5320 MHz

2 channels are provided for 802.11n (HT40), 802.11ac (VHT40):

Channel	Frequency	Channel	Frequency
54	5270 MHz	62	5310 MHz

1 channel is provided for 802.11ac (VHT80):

Channel	Frequency
58	5290 MHz

FOR 5500 ~ 5720MHz

12 channels are provided for 802.11a, 802.11n (HT20), 802.11ac (VHT20):

Channel	Frequency	Channel	Frequency
100	5500 MHz	124	5620 MHz
104	5520 MHz	128	5640 MHz
108	5540 MHz	132	5660 MHz
112	5560 MHz	136	5680 MHz
116	5580 MHz	140	5700 MHz
120	5600 MHz	144	5720 MHz

6 channels are provided for 802.11n (HT40), 802.11ac (VHT40):

Channel	Frequency	Channel	Frequency
102	5510 MHz	126	5630 MHz
110	5550 MHz	134	5670 MHz
118	5590 MHz	142	5710 MHz

3 channels are provided for 802.11ac (VHT80):

Channel	Frequency	Channel	Frequency
106	5530 MHz	138	5690 MHz
122	5610 MHz		

3.2.1 Test Mode Applicability and Tested Channel Detail

EUT Configure Mode	Applicable To				Description
	RE \geq 1G	RE<1G	PLC	APCM	
1	√	√	√	√	Adapter No. 2
2	-	-	√	-	Adapter No. 1

Where **RE \geq 1G**: Radiated Emission above 1GHz

RE<1G: Radiated Emission below 1GHz

PLC: Power Line Conducted Emission

APCM: Antenna Port Conducted Measurement

Note: "-" means no effect.

Radiated Emission Test (Above 1GHz):

- Pre-Scan has been conducted to determine the worst-case mode from all possible combinations between available modulations, data rates and antenna ports (if EUT with antenna diversity architecture).
- Following channel(s) was (were) selected for the final test as listed below.

CDD Mode						
Mode	FREQ. Band (MHz)	Available Channel	Tested Channel	Modulation Technology	Modulation Type	Data Rate (Mbps)
802.11a	5260-5320	52 to 64	52, 60, 64	OFDM	BPSK	6
802.11ac (VHT20)		52 to 64	52, 60, 64	OFDM	BPSK	6.5
802.11ac (VHT40)		54 to 62	54, 62	OFDM	BPSK	13.5
802.11ac (VHT80)		58	58	OFDM	BPSK	29.3
802.11a	5500-5720	100 to 144	100, 116, 140, 144	OFDM	BPSK	6
802.11ac (VHT20)		100 to 144	100, 116, 140, 144	OFDM	BPSK	6.5
802.11ac (VHT40)		102 to 142	102, 110, 134, 142	OFDM	BPSK	13.5
802.11ac (VHT80)		106 to 138	106, 122, 138	OFDM	BPSK	29.3

Radiated Emission Test (Below 1GHz):

- Pre-Scan has been conducted to determine the worst-case mode from all possible combinations between available modulations, data rates and antenna ports (if EUT with antenna diversity architecture).
- Following channel(s) was (were) selected for the final test as listed below.

CDD Mode						
Mode	FREQ. Band (MHz)	Available Channel	Tested Channel	Modulation Technology	Modulation Type	Data Rate (Mbps)
802.11ac (VHT40)	5260-5320, 5500-5720	54 to 62, 102 to 142	54	OFDM	BPSK	13.5

Power Line Conducted Emission Test:

- Pre-Scan has been conducted to determine the worst-case mode from all possible combinations between available modulations, data rates and antenna ports (if EUT with antenna diversity architecture).
- Following channel(s) was (were) selected for the final test as listed below.

CDD Mode						
Mode	FREQ. Band (MHz)	Available Channel	Tested Channel	Modulation Technology	Modulation Type	Data Rate (Mbps)
802.11ac (VHT40)	5260-5320, 5500-5720	54 to 62, 102 to 142	54	OFDM	BPSK	13.5

Antenna Port Conducted Measurement:

- This item includes all test value of each mode, but only includes spectrum plot of worst value of each mode.
- Pre-Scan has been conducted to determine the worst-case mode from all possible combinations between available modulations, data rates and antenna ports (if EUT with antenna diversity architecture).
- Following channel(s) was (were) selected for the final test as listed below.

CDD Mode						
Mode	FREQ. Band (MHz)	Available Channel	Tested Channel	Modulation Technology	Modulation Type	Data Rate (Mbps)
802.11a	5260-5320	52 to 64	52, 60, 64	OFDM	BPSK	6
802.11ac (VHT20)		52 to 64	52, 60, 64	OFDM	BPSK	6.5
802.11ac (VHT40)		54 to 62	54, 62	OFDM	BPSK	13.5
802.11ac (VHT80)		58	58	OFDM	BPSK	29.3
802.11a	5500-5720	100 to 144	100, 116, 140, 144	OFDM	BPSK	6
802.11ac (VHT20)		100 to 144	100, 116, 140, 144	OFDM	BPSK	6.5
802.11ac (VHT40)		102 to 142	102, 110, 134, 142	OFDM	BPSK	13.5
802.11ac (VHT80)		106 to 138	106, 122, 138	OFDM	BPSK	29.3
Beamforming Mode (output power only) / SDM Mode (output power only)						
Mode	FREQ. Band (MHz)	Available Channel	Tested Channel	Modulation Technology	Modulation Type	Data Rate (Mbps)
802.11ac (VHT20)	5260-5320	52 to 64	52, 60, 64	OFDM	BPSK	6.5
802.11ac (VHT40)		54 to 62	54, 62	OFDM	BPSK	13.5
802.11ac (VHT80)		58	58	OFDM	BPSK	29.3
802.11ac (VHT20)	5500-5720	100 to 144	100, 116, 140, 144	OFDM	BPSK	6.5
802.11ac (VHT40)		102 to 142	102, 110, 134, 142	OFDM	BPSK	13.5
802.11ac (VHT80)		106 to 138	106, 122, 138	OFDM	BPSK	29.3

Test Condition:

Applicable To	Environmental Conditions	Input Power	Tested By
RE \geq 1G	23deg. C, 63%RH	120Vac, 60Hz	Frank Chuang
RE<1G	21deg. C, 67%RH	120Vac, 60Hz	Eason Tseng
PLC	25deg. C, 75%RH	120Vac, 60Hz	Frank Chuang
APCM	21deg. C, 60%RH	120Vac, 60Hz	Jyunchun Lin

3.3 Duty Cycle of Test Signal

If duty cycle of test signal is $\geq 98\%$, duty factor is not required.

If duty cycle of test signal is $< 98\%$, duty factor shall be considered.

802.11a: Duty cycle = $0.561 \text{ ms} / 0.615 \text{ ms} = 0.912$, Duty factor = $10 * \log(1/\text{Duty cycle}) = 0.4$

802.11ac (VHT20): Duty cycle = $4.97 \text{ ms} / 5.065 \text{ ms} = 0.981$

802.11ac (VHT40): Duty cycle = $2.415 \text{ ms} / 2.492 \text{ ms} = 0.969$, Duty factor = $10 * \log(1/\text{Duty cycle}) = 0.14$

802.11ac (VHT80): Duty cycle = $1.139 \text{ ms} / 1.201 \text{ ms} = 0.948$, Duty factor = $10 * \log(1/\text{Duty cycle}) = 0.23$

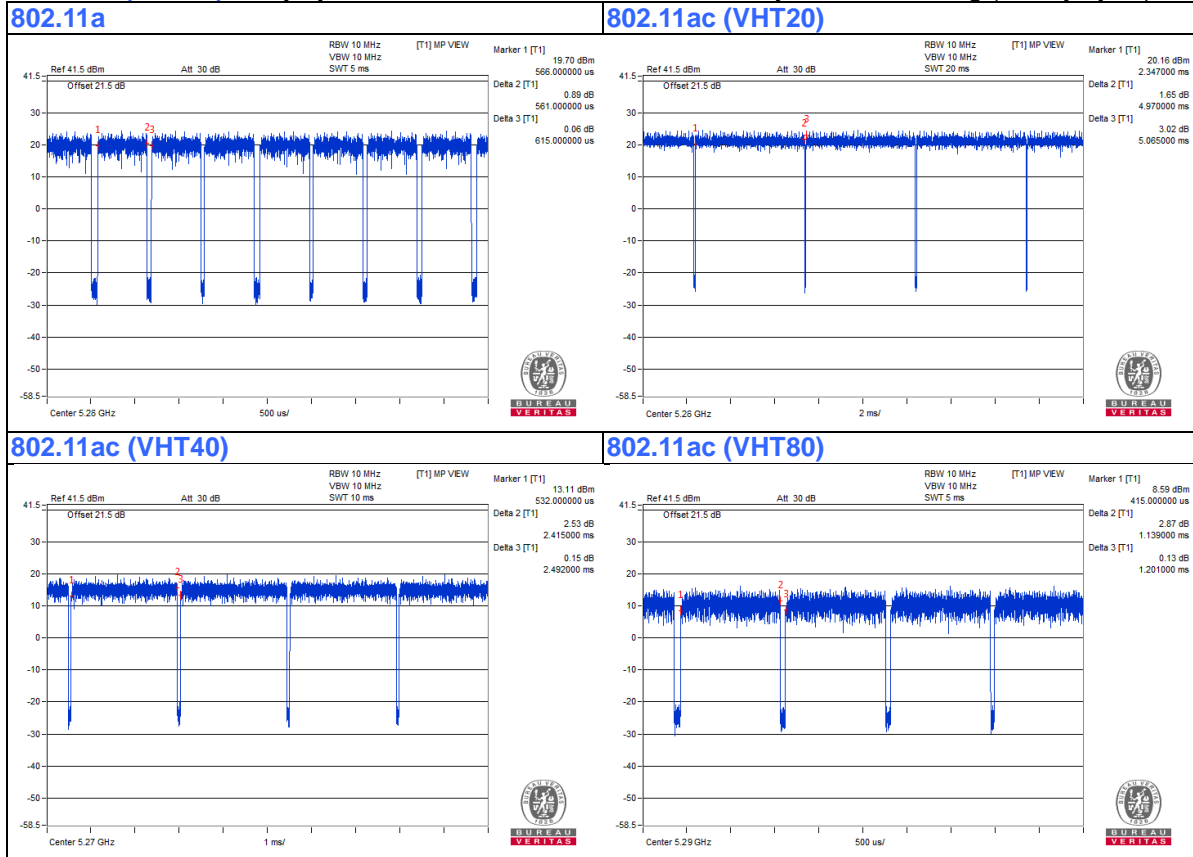

3.4 Description of Support Units

The EUT has been tested as an independent unit together with other necessary accessories or support units. The following support units or accessories were used to form a representative test configuration during the tests.

ID	Product	Brand	Model No.	Serial No.	FCC ID	Remarks
A.	iPod	Apple	MC749TA/A	CC4DMFKUDFDM	NA	Provided by Lab
B.	iPod	Apple	MD778TA/A	CC4JMH7LF4T1	NA	Provided by Lab
C.	Laptop	DELL	E5430	HYV4VY1	FCC DoC	Provided by Lab
D.	Laptop	DELL	E6420	B92T3R1	FCC DoC	Provided by Lab

Note:

1. All power cords of the above support units are non-shielded (1.8m).

ID	Descriptions	Qty.	Length (m)	Shielding (Yes/No)	Cores (Qty.)	Remarks
1.	USB Cable	1	0.1	Yes	0	Provided by Lab
2.	USB Cable	1	0.1	Yes	0	Provided by Lab
3.	RJ-45 Cable	1	10	No	0	Provided by Lab
4.	RJ-45 Cable	1	10	No	0	Provided by Lab
5.	Coaxial Cable	1	10	Yes	0	Provided by Lab
6.	DC Cable	1	1.5	No	0	Supplied by client

3.4.1 Configuration of System under Test

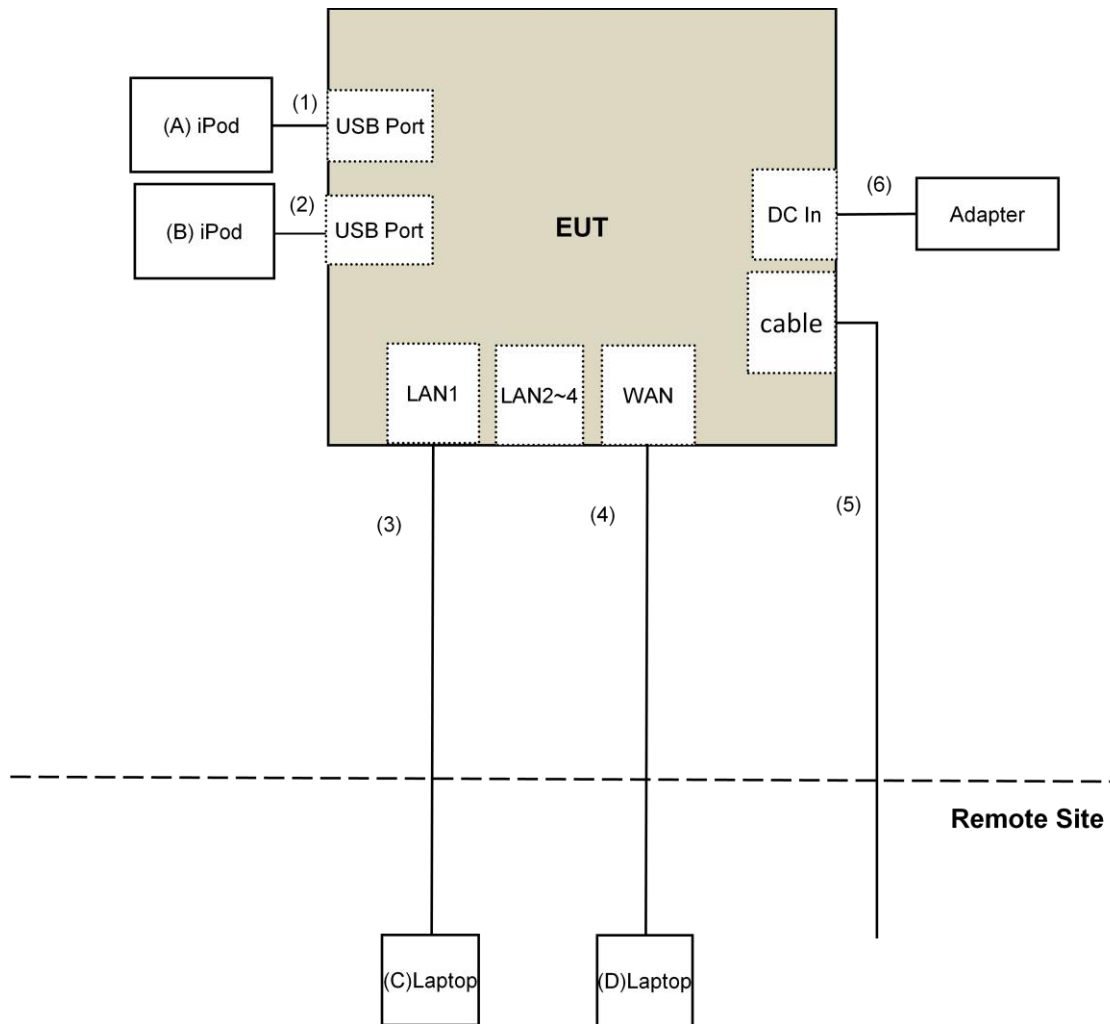

3.5 General Description of Applied Standard

The EUT is a RF Product. According to the specifications of the manufacturer, it must comply with the requirements of the following standards:

FCC Part 15, Subpart E (15.407)

KDB 789033 D02 General UNII Test Procedure New Rules v02r01

KDB 662911 D01 Multiple Transmitter Output v02r01

ANSI C63.10-2013

All test items have been performed and recorded as per the above standards.

4 Test Types and Results

4.1 Radiated Emission and Bandedge Measurement

4.1.1 Limits of Radiated Emission and Bandedge Measurement

Radiated emissions which fall in the restricted bands must comply with the radiated emission limits specified as below table.

Frequencies (MHz)	Field Strength (microvolts/meter)	Measurement Distance (meters)
0.009 ~ 0.490	2400/F(kHz)	300
0.490 ~ 1.705	24000/F(kHz)	30
1.705 ~ 30.0	30	30
30 ~ 88	100	3
88 ~ 216	150	3
216 ~ 960	200	3
Above 960	500	3

NOTE:

- The lower limit shall apply at the transition frequencies.
- Emission level (dBuV/m) = 20 log Emission level (uV/m).
- For frequencies above 1000MHz, the field strength limits are based on average detector, however, the peak field strength of any emission shall not exceed the maximum permitted average limits, specified above by more than 20dB under any condition of modulation.

Limits of unwanted emission out of the restricted bands

Applicable To		Limit	
789033 D02 General UNII Test Procedure New Rules v02r01		Field Strength at 3m	
		PK:74 (dBuV/m)	AV:54 (dBuV/m)
Frequency Band	Applicable To	EIRP Limit	Equivalent Field Strength at 3m
5150~5250 MHz	15.407(b)(1)	PK:-27 (dBm/MHz)	PK:68.2(dBuV/m)
5250~5350 MHz	15.407(b)(2)		
5470~5725 MHz	15.407(b)(3)		
5725~5850 MHz	<input checked="" type="checkbox"/> 15.407(b)(4)(i)	PK:-27 (dBm/MHz) ^{*1} PK:10 (dBm/MHz) ^{*2} PK:15.6 (dBm/MHz) ^{*3} PK:27 (dBm/MHz) ^{*4}	PK: 68.2(dBuV/m) ^{*1} PK:105.2 (dBuV/m) ^{*2} PK: 110.8(dBuV/m) ^{*3} PK:122.2 (dBuV/m) ^{*4}
	<input type="checkbox"/> 15.407(b)(4)(ii)	Emission limits in section 15.247(d)	
^{*1} beyond 75 MHz or more above of the band edge.		^{*2} below the band edge increasing linearly to 10 dBm/MHz at 25 MHz above.	
^{*3} below the band edge increasing linearly to a level of 15.6 dBm/MHz at 5 MHz above.		^{*4} from 5 MHz above or below the band edge increasing linearly to a level of 27 dBm/MHz at the band edge.	

Note:

The following formula is used to convert the equipment isotropic radiated power (eirp) to field strength:

$$E = \frac{1000000\sqrt{30P}}{3} \mu\text{V/m, where P is the eirp (Watts).}$$

4.1.2 Test Instruments

DESCRIPTION & MANUFACTURER	MODEL NO.	SERIAL NO.	CALIBRATED DATE	CALIBRATED UNTIL
Test Receiver Agilent	N9038A	MY50010156	July 12, 2018	July 11, 2019
Pre-Amplifier EMCI	EMC001340	980142	Feb. 09, 2018	Feb. 08, 2019
Loop Antenna(*) Electro-Metrics	EM-6879	264	Dec. 16, 2016	Dec. 15, 2018
RF Cable	NA	LOOPCAB-001	Jan. 15, 2018	Jan. 14, 2019
RF Cable	NA	LOOPCAB-002	Jan. 15, 2018	Jan. 14, 2019
Pre-Amplifier Mini-Circuits	ZFL-1000VH2B	AMP-ZFL-05	May 05, 2018	May 04, 2019
Trilog Broadband Antenna SCHWARZBECK	VULB 9168	9168-361	Nov. 29, 2017	Nov. 28, 2018
RF Cable	8D	966-3-1	Mar. 20, 2018	Mar. 19, 2019
RF Cable	8D	966-3-2	Mar. 20, 2018	Mar. 19, 2019
RF Cable	8D	966-3-3	Mar. 20, 2018	Mar. 19, 2019
Fixed attenuator Mini-Circuits	UNAT-5+	PAD-3m-3-01	Oct. 03, 2017	Oct. 02, 2018
Horn_Antenna SCHWARZBECK	BBHA9120-D	9120D-406	Dec. 12, 2017	Dec. 11, 2018
Pre-Amplifier EMCI	EMC12630SE	980384	Jan. 29, 2018	Jan. 28, 2019
RF Cable	EMC104-SM-SM-1200	160922	Jan. 29, 2018	Jan. 28, 2019
RF Cable	EMC104-SM-SM-2000	150317	Jan. 29, 2018	Jan. 28, 2019
RF Cable	EMC104-SM-SM-5000	150322	Jan. 29, 2018	Jan. 28, 2019
Spectrum Analyzer Keysight	N9030A	MY54490679	July 23, 2018	July 22, 2019
Pre-Amplifier EMCI	EMC184045SE	980386	Jan. 29, 2018	Jan. 28, 2019
Horn_Antenna SCHWARZBECK	BBHA 9170	BBHA9170608	Dec. 14, 2017	Dec. 13, 2018
RF Cable	EMC102-KM-KM-1200	160924	Jan. 29, 2018	Jan. 28, 2019
Software	ADT_Radiated_V8.7.08	NA	NA	NA
Antenna Tower & Turn Table Max-Full	MF-7802	MF780208406	NA	NA
Boresight Antenna Fixture	FBA-01	FBA-SIP01	NA	NA
Spectrum Analyzer R&S	FSV40	100964	June 20, 2018	June 19, 2019
Power meter Anritsu	ML2495A	1014008	May 09, 2018	May 08, 2019
Power sensor Anritsu	MA2411B	0917122	May 09, 2018	May 08, 2019
AC Power Source Extech Electronics	6205	1440452	NA	NA
Temperature & Humidity Chamber Giant Force	GTH-150-40-SP-AR	MAA0812-008	Jan. 10, 2018	Jan. 09, 2019
True RMS Clamp Meter FLUKE	325	31130711WS	May 22, 2018	May 21, 2019

Note:

1. The calibration interval of the above test instruments is 12 months and the calibrations are traceable to NML/ROC and NIST/USA.
2. *The calibration interval of the above test instruments is 24 months and the calibrations are traceable to NML/ROC and NIST/USA.
3. The test was performed in 966 Chamber No. 3.
4. The CANADA Site Registration No. is 20331-1
5. Loop antenna was used for all emissions below 30 MHz.
6. Tested Date: Aug. 09 to 27, 2018

4.1.3 Test Procedure

For Radiated emission below 30MHz

- a. The EUT was placed on the top of a rotating table 0.8 meters above the ground at a 3 meter chamber room. The table was rotated 360 degrees to determine the position of the highest radiation.
- b. The EUT was set 3 meters away from the interference-receiving antenna, which was mounted on the top of a variable-height antenna tower.
- c. Parallel, perpendicular, and ground-parallel orientations of the antenna are set to make the measurement.
- d. For each suspected emission, the EUT was arranged to its worst case and the rotatable table was turned from 0 degrees to 360 degrees to find the maximum reading.
- e. The test-receiver system was set to Quasi-Peak Detect Function and Specified Bandwidth with Maximum Hold Mode.

Note:

1. The resolution bandwidth and video bandwidth of test receiver/spectrum analyzer is 9kHz at frequency below 30MHz.

For Radiated emission above 30MHz

- a. The EUT was placed on the top of a rotating table 0.8 meters (for 30MHz ~ 1GHz) / 1.5 meters (for above 1GHz) above the ground at 3 meter chamber room for test. The table was rotated 360 degrees to determine the position of the highest radiation.
- b. The EUT was set 3 meters away from the interference-receiving antenna, which was mounted on the top of a variable-height antenna tower.
- c. The height of antenna is varied from one meter to four meters above the ground to determine the maximum value of the field strength. Both horizontal and vertical polarizations of the antenna are set to make the measurement.
- d. For each suspected emission, the EUT was arranged to its worst case and then the antenna was tuned to heights from 1 meter to 4 meters and the rotatable table was turned from 0 degrees to 360 degrees to find the maximum reading.
- e. The test-receiver system was set to quasi-peak detect function and specified bandwidth with maximum hold mode when the test frequency is below 1 GHz.
- f. The test-receiver system was set to peak and average detects function and specified bandwidth with maximum hold mode when the test frequency is above 1 GHz. If the peak reading value also meets average limit, measurement with the average detector is unnecessary.

Note:

1. The resolution bandwidth and video bandwidth of test receiver/spectrum analyzer is 120kHz for Quasi-peak detection (QP) at frequency below 1GHz.
2. The resolution bandwidth of test receiver/spectrum analyzer is 1 MHz and the video bandwidth is 3 MHz for Peak detection (PK) at frequency above 1GHz.
3. The resolution bandwidth of test receiver/spectrum analyzer is 1MHz and the video bandwidth is $\geq 1/T$ (Duty cycle < 98%) or 10Hz (Duty cycle $\geq 98\%$) for Average detection (AV) at frequency above 1GHz.
4. All modes of operation were investigated and the worst-case emissions are reported.

4.1.4 Deviation from Test Standard

No deviation.

4.1.5 Test Setup

For Radiated emission below 30MHz

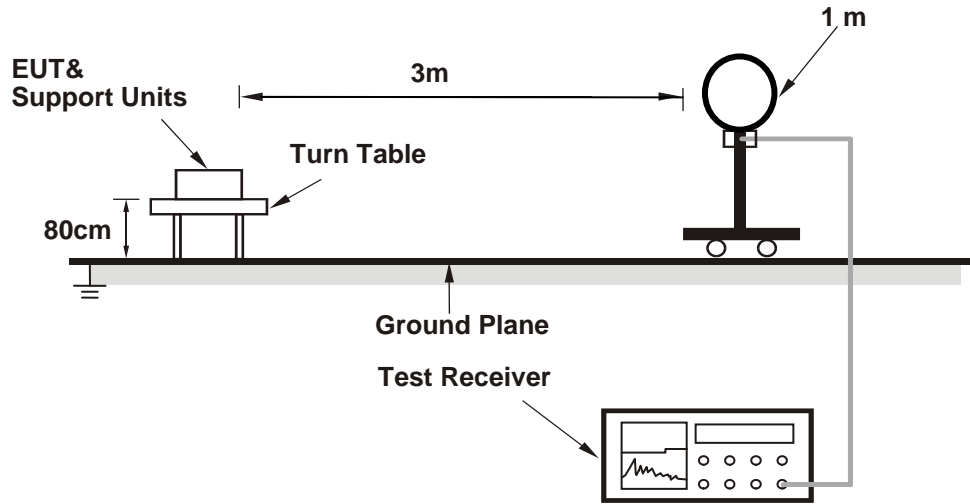

For Radiated emission 30MHz to 1GHz

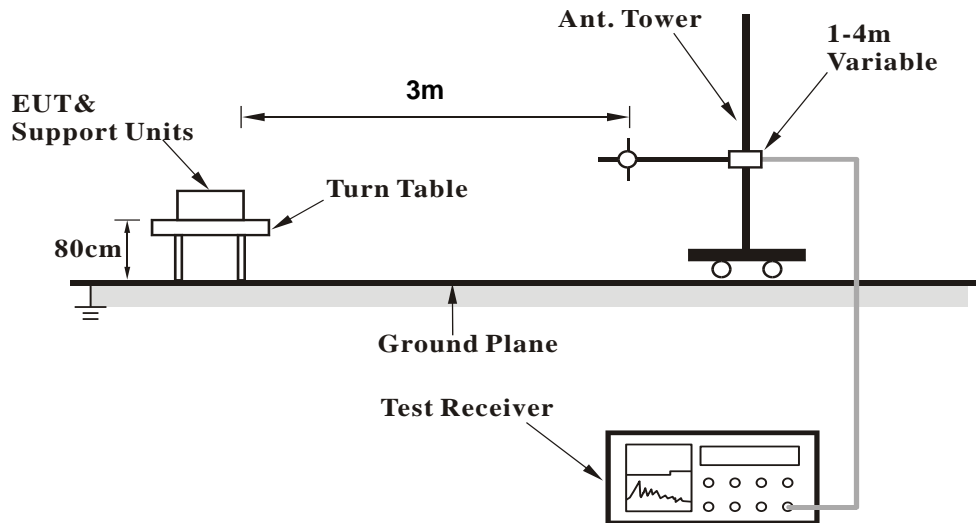

For Radiated emission above 1GHz

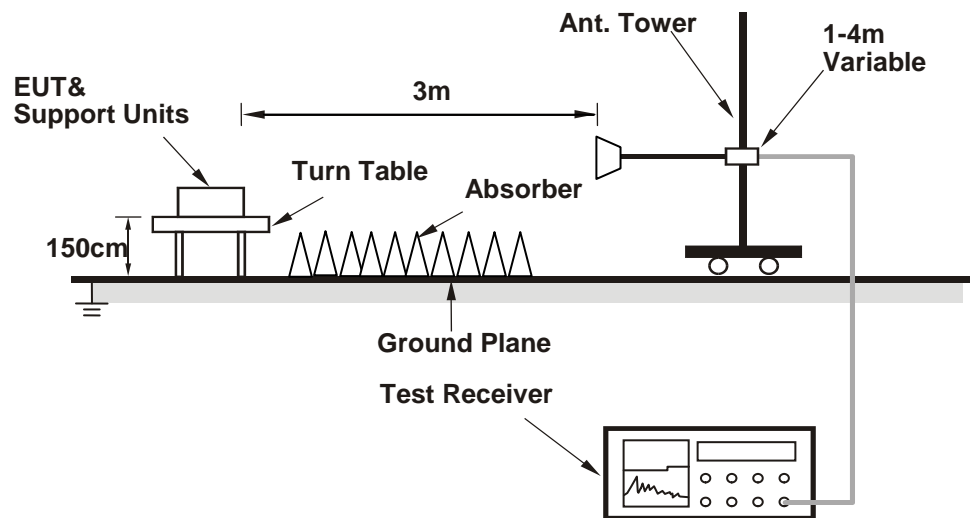

For the actual test configuration, please refer to the attached file (Test Setup Photo).

4.1.6 EUT Operating Condition

- Connected the EUT with the Laptop which is placed on remote site.
- Controlling software (Telnet paste command) has been activated to set the EUT on specific status.

4.1.7 Test Results

CDD Mode

Above 1GHz Data:

802.11a

CHANNEL	TX Channel 52	DETECTOR FUNCTION	Peak (PK)
FREQUENCY RANGE	1GHz ~ 40GHz		Average (AV)

ANTENNA POLARITY & TEST DISTANCE: HORIZONTAL AT 3 M

NO.	FREQ. (MHz)	EMISSION LEVEL (dBuV/m)	LIMIT (dBuV/m)	MARGIN (dB)	ANTENNA HEIGHT (m)	TABLE ANGLE (Degree)	RAW VALUE (dBuV)	CORRECTION FACTOR (dB/m)
1	5150.00	50.4 PK	74.0	-23.6	1.54 H	309	47.8	2.6
2	5150.00	39.8 AV	54.0	-14.2	1.54 H	309	37.2	2.6
3	*5260.00	113.5 PK			1.54 H	309	111.4	2.1
4	*5260.00	103.4 AV			1.54 H	309	101.3	2.1
5	#10520.00	54.1 PK	68.2	-14.1	1.46 H	154	41.7	12.4
6	15780.00	63.2 PK	74.0	-10.8	1.38 H	318	51.7	11.5
7	15780.00	48.0 AV	54.0	-6.0	1.38 H	318	36.5	11.5

ANTENNA POLARITY & TEST DISTANCE: VERTICAL AT 3 M

NO.	FREQ. (MHz)	EMISSION LEVEL (dBuV/m)	LIMIT (dBuV/m)	MARGIN (dB)	ANTENNA HEIGHT (m)	TABLE ANGLE (Degree)	RAW VALUE (dBuV)	CORRECTION FACTOR (dB/m)
1	5150.00	53.4 PK	74.0	-20.6	2.26 V	262	50.8	2.6
2	5150.00	42.9 AV	54.0	-11.1	2.26 V	262	40.3	2.6
3	*5260.00	113.6 PK			2.26 V	262	111.5	2.1
4	*5260.00	105.0 AV			2.26 V	262	102.9	2.1
5	#10520.00	56.4 PK	68.2	-11.8	3.90 V	103	44.0	12.4
6	15780.00	64.6 PK	74.0	-9.4	1.53 V	98	53.1	11.5
7	15780.00	50.1 AV	54.0	-3.9	1.53 V	98	38.6	11.5

REMARKS:

1. Emission Level(dBuV/m) = Raw Value(dBuV) + Correction Factor(dB/m)
2. Correction Factor(dB/m) = Antenna Factor(dB/m) + Cable Factor(dB) – Pre-Amplifier Factor(dB)
3. The other emission levels were very low against the limit.
4. Margin value = Emission Level – Limit value
5. " * ": Fundamental frequency.
6. " # ": The radiated frequency is out of the restricted band.

CHANNEL	TX Channel 60	DETECTOR FUNCTION	Peak (PK)
FREQUENCY RANGE	1GHz ~ 40GHz		Average (AV)

ANTENNA POLARITY & TEST DISTANCE: HORIZONTAL AT 3 M

NO.	FREQ. (MHz)	EMISSION LEVEL (dBuV/m)	LIMIT (dBuV/m)	MARGIN (dB)	ANTENNA HEIGHT (m)	TABLE ANGLE (Degree)	RAW VALUE (dBuV)	CORRECTION FACTOR (dB/m)
1	*5300.00	113.5 PK			1.52 H	324	111.3	2.2
2	*5300.00	103.4 AV			1.52 H	324	101.2	2.2
3	5350.00	50.2 PK	74.0	-23.8	1.52 H	324	47.9	2.3
4	5350.00	39.7 AV	54.0	-14.3	1.52 H	324	37.4	2.3
5	10600.00	54.1 PK	74.0	-19.9	1.45 H	154	42.4	11.7
6	10600.00	40.2 AV	54.0	-13.8	1.45 H	154	28.5	11.7
7	15900.00	62.8 PK	74.0	-11.2	1.41 H	324	51.6	11.2
8	15900.00	47.5 AV	54.0	-6.5	1.41 H	324	36.3	11.2

ANTENNA POLARITY & TEST DISTANCE: VERTICAL AT 3 M

NO.	FREQ. (MHz)	EMISSION LEVEL (dBuV/m)	LIMIT (dBuV/m)	MARGIN (dB)	ANTENNA HEIGHT (m)	TABLE ANGLE (Degree)	RAW VALUE (dBuV)	CORRECTION FACTOR (dB/m)
1	*5300.00	114.5 PK			2.23 V	268	112.3	2.2
2	*5300.00	105.7 AV			2.23 V	268	103.5	2.2
3	5350.00	53.3 PK	74.0	-20.7	2.23 V	268	51.0	2.3
4	5350.00	42.9 AV	54.0	-11.1	2.23 V	268	40.6	2.3
5	10600.00	56.3 PK	74.0	-17.7	3.91 V	97	44.6	11.7
6	10600.00	42.8 AV	54.0	-11.2	3.91 V	97	31.1	11.7
7	15900.00	64.2 PK	74.0	-9.8	1.57 V	121	53.0	11.2
8	15900.00	49.8 AV	54.0	-4.2	1.57 V	121	38.6	11.2

REMARKS:

1. Emission Level(dBuV/m) = Raw Value(dBuV) + Correction Factor(dB/m)
2. Correction Factor(dB/m) = Antenna Factor(dB/m) + Cable Factor(dB) – Pre-Amplifier Factor(dB)
3. The other emission levels were very low against the limit.
4. Margin value = Emission Level – Limit value
5. " * ": Fundamental frequency.

CHANNEL	TX Channel 64	DETECTOR FUNCTION	Peak (PK)
FREQUENCY RANGE	1GHz ~ 40GHz		Average (AV)

ANTENNA POLARITY & TEST DISTANCE: HORIZONTAL AT 3 M

NO.	FREQ. (MHz)	EMISSION LEVEL (dBuV/m)	LIMIT (dBuV/m)	MARGIN (dB)	ANTENNA HEIGHT (m)	TABLE ANGLE (Degree)	RAW VALUE (dBuV)	CORRECTION FACTOR (dB/m)
1	*5320.00	113.3 PK			1.57 H	328	111.0	2.3
2	*5320.00	103.0 AV			1.57 H	328	100.7	2.3
3	5350.00	50.4 PK	74.0	-23.6	1.57 H	328	48.1	2.3
4	5350.00	39.9 AV	54.0	-14.1	1.57 H	328	37.6	2.3
5	10640.00	54.5 PK	74.0	-19.5	1.46 H	145	42.8	11.7
6	10640.00	40.4 AV	54.0	-13.6	1.46 H	145	28.7	11.7
7	15960.00	62.2 PK	74.0	-11.8	1.40 H	310	50.8	11.4
8	15960.00	47.0 AV	54.0	-7.0	1.40 H	310	35.6	11.4

ANTENNA POLARITY & TEST DISTANCE: VERTICAL AT 3 M

NO.	FREQ. (MHz)	EMISSION LEVEL (dBuV/m)	LIMIT (dBuV/m)	MARGIN (dB)	ANTENNA HEIGHT (m)	TABLE ANGLE (Degree)	RAW VALUE (dBuV)	CORRECTION FACTOR (dB/m)
1	*5320.00	114.7 PK			1.50 V	244	112.4	2.3
2	*5320.00	105.8 AV			1.50 V	244	103.5	2.3
3	5350.00	63.7 PK	74.0	-10.3	1.50 V	244	61.4	2.3
4	5350.00	50.6 AV	54.0	-3.4	1.50 V	244	48.3	2.3
5	10640.00	56.2 PK	74.0	-17.8	3.97 V	81	44.5	11.7
6	10640.00	42.4 AV	54.0	-11.6	3.97 V	81	30.7	11.7
7	15960.00	64.1 PK	74.0	-9.9	1.48 V	101	52.7	11.4
8	15960.00	49.5 AV	54.0	-4.5	1.48 V	101	38.1	11.4

REMARKS:

1. Emission Level(dBuV/m) = Raw Value(dBuV) + Correction Factor(dB/m)
2. Correction Factor(dB/m) = Antenna Factor(dB/m) + Cable Factor(dB) – Pre-Amplifier Factor(dB)
3. The other emission levels were very low against the limit.
4. Margin value = Emission Level – Limit value
5. " * ": Fundamental frequency.

CHANNEL	TX Channel 100	DETECTOR FUNCTION	Peak (PK)
FREQUENCY RANGE	1GHz ~ 40GHz		Average (AV)

ANTENNA POLARITY & TEST DISTANCE: HORIZONTAL AT 3 M

NO.	FREQ. (MHz)	EMISSION LEVEL (dBuV/m)	LIMIT (dBuV/m)	MARGIN (dB)	ANTENNA HEIGHT (m)	TABLE ANGLE (Degree)	RAW VALUE (dBuV)	CORRECTION FACTOR (dB/m)
1	5460.00	56.1 PK	74.0	-17.9	1.48 H	324	53.5	2.6
2	5460.00	45.7 AV	54.0	-8.3	1.48 H	324	43.1	2.6
3	#5470.00	64.8 PK	68.2	-3.4	1.48 H	324	62.2	2.6
4	*5500.00	113.0 PK			1.48 H	324	110.5	2.5
5	*5500.00	103.0 AV			1.48 H	324	100.5	2.5
6	11000.00	54.5 PK	74.0	-19.5	1.48 H	145	42.3	12.2
7	11000.00	40.4 AV	54.0	-13.6	1.48 H	145	28.2	12.2
8	#16500.00	51.5 PK	68.2	-16.7	1.46 H	317	37.8	13.7

ANTENNA POLARITY & TEST DISTANCE: VERTICAL AT 3 M

NO.	FREQ. (MHz)	EMISSION LEVEL (dBuV/m)	LIMIT (dBuV/m)	MARGIN (dB)	ANTENNA HEIGHT (m)	TABLE ANGLE (Degree)	RAW VALUE (dBuV)	CORRECTION FACTOR (dB/m)
1	5460.00	59.0 PK	74.0	-15.0	1.81 V	355	56.4	2.6
2	5460.00	48.8 AV	54.0	-5.2	1.81 V	355	46.2	2.6
3	#5470.00	67.9 PK	68.2	-0.3	1.81 V	355	65.3	2.6
4	*5500.00	114.3 PK			1.81 V	355	111.8	2.5
5	*5500.00	105.4 AV			1.81 V	355	102.9	2.5
6	11000.00	56.1 PK	74.0	-17.9	3.89 V	86	43.9	12.2
7	11000.00	42.1 AV	54.0	-11.9	3.89 V	86	29.9	12.2
8	#16500.00	53.9 PK	68.2	-14.3	1.50 V	102	40.2	13.7

REMARKS:

1. Emission Level(dBuV/m) = Raw Value(dBuV) + Correction Factor(dB/m)
2. Correction Factor(dB/m) = Antenna Factor(dB/m) + Cable Factor(dB) – Pre-Amplifier Factor(dB)
3. The other emission levels were very low against the limit.
4. Margin value = Emission Level – Limit value
5. " * ": Fundamental frequency.
6. " # ": The radiated frequency is out of the restricted band.

CHANNEL	TX Channel 116	DETECTOR FUNCTION	Peak (PK)
FREQUENCY RANGE	1GHz ~ 40GHz		Average (AV)

ANTENNA POLARITY & TEST DISTANCE: HORIZONTAL AT 3 M

NO.	FREQ. (MHz)	EMISSION LEVEL (dBuV/m)	LIMIT (dBuV/m)	MARGIN (dB)	ANTENNA HEIGHT (m)	TABLE ANGLE (Degree)	RAW VALUE (dBuV)	CORRECTION FACTOR (dB/m)
1	5460.00	55.9 PK	74.0	-18.1	1.53 H	339	53.3	2.6
2	5460.00	44.1 AV	54.0	-9.9	1.53 H	339	41.5	2.6
3	#5470.00	55.6 PK	68.2	-12.6	1.53 H	339	53.0	2.6
4	*5580.00	112.9 PK			1.53 H	339	110.1	2.8
5	*5580.00	102.9 AV			1.53 H	339	100.1	2.8
6	11160.00	54.2 PK	74.0	-19.8	1.49 H	132	42.2	12.0
7	11160.00	40.3 AV	54.0	-13.7	1.49 H	132	28.3	12.0
8	#16740.00	51.6 PK	68.2	-16.6	1.58 H	328	37.4	14.2

ANTENNA POLARITY & TEST DISTANCE: VERTICAL AT 3 M

NO.	FREQ. (MHz)	EMISSION LEVEL (dBuV/m)	LIMIT (dBuV/m)	MARGIN (dB)	ANTENNA HEIGHT (m)	TABLE ANGLE (Degree)	RAW VALUE (dBuV)	CORRECTION FACTOR (dB/m)
1	5460.00	58.9 PK	74.0	-15.1	1.50 V	355	56.3	2.6
2	5460.00	47.4 AV	54.0	-6.6	1.50 V	355	44.8	2.6
3	#5470.00	58.7 PK	68.2	-9.5	1.50 V	355	56.1	2.6
4	*5580.00	113.8 PK			1.50 V	355	111.0	2.8
5	*5580.00	105.0 AV			1.50 V	355	102.2	2.8
6	11160.00	56.3 PK	74.0	-17.7	3.91 V	77	44.3	12.0
7	11160.00	42.0 AV	54.0	-12.0	3.91 V	77	30.0	12.0
8	#16740.00	54.2 PK	68.2	-14.0	1.51 V	101	40.0	14.2

REMARKS:

1. Emission Level(dBuV/m) = Raw Value(dBuV) + Correction Factor(dB/m)
2. Correction Factor(dB/m) = Antenna Factor(dB/m) + Cable Factor(dB) – Pre-Amplifier Factor(dB)
3. The other emission levels were very low against the limit.
4. Margin value = Emission Level – Limit value
5. " * ": Fundamental frequency.
6. " # ": The radiated frequency is out of the restricted band.

CHANNEL	TX Channel 140	DETECTOR FUNCTION	Peak (PK)
FREQUENCY RANGE	1GHz ~ 40GHz		Average (AV)

ANTENNA POLARITY & TEST DISTANCE: HORIZONTAL AT 3 M

NO.	FREQ. (MHz)	EMISSION LEVEL (dBuV/m)	LIMIT (dBuV/m)	MARGIN (dB)	ANTENNA HEIGHT (m)	TABLE ANGLE (Degree)	RAW VALUE (dBuV)	CORRECTION FACTOR (dB/m)
1	*5700.00	113.1 PK			1.54 H	352	110.2	2.9
2	*5700.00	103.2 AV			1.54 H	352	100.3	2.9
3	#5725.00	64.1 PK	68.2	-4.1	1.54 H	352	61.2	2.9
4	11400.00	53.7 PK	74.0	-20.3	1.44 H	135	40.7	13.0
5	11400.00	40.0 AV	54.0	-14.0	1.44 H	135	27.0	13.0
6	#17100.00	51.8 PK	68.2	-16.4	1.59 H	323	35.7	16.1

ANTENNA POLARITY & TEST DISTANCE: VERTICAL AT 3 M

NO.	FREQ. (MHz)	EMISSION LEVEL (dBuV/m)	LIMIT (dBuV/m)	MARGIN (dB)	ANTENNA HEIGHT (m)	TABLE ANGLE (Degree)	RAW VALUE (dBuV)	CORRECTION FACTOR (dB/m)
1	*5700.00	112.7 PK			1.73 V	296	109.8	2.9
2	*5700.00	104.3 AV			1.73 V	296	101.4	2.9
3	#5725.00	68.1 PK	68.2	-0.1	1.73 V	296	65.2	2.9
4	11400.00	55.9 PK	74.0	-18.1	3.97 V	82	42.9	13.0
5	11400.00	41.8 AV	54.0	-12.2	3.97 V	82	28.8	13.0
6	#17100.00	53.8 PK	68.2	-14.4	1.58 V	107	37.7	16.1

REMARKS:

1. Emission Level(dBuV/m) = Raw Value(dBuV) + Correction Factor(dB/m)
2. Correction Factor(dB/m) = Antenna Factor(dB/m) + Cable Factor(dB) – Pre-Amplifier Factor(dB)
3. The other emission levels were very low against the limit.
4. Margin value = Emission Level – Limit value
5. " * ": Fundamental frequency.
6. " # ": The radiated frequency is out of the restricted band.

CHANNEL	TX Channel 144	DETECTOR FUNCTION	Peak (PK)
FREQUENCY RANGE	1GHz ~ 40GHz		Average (AV)

ANTENNA POLARITY & TEST DISTANCE: HORIZONTAL AT 3 M

NO.	FREQ. (MHz)	EMISSION LEVEL (dBuV/m)	LIMIT (dBuV/m)	MARGIN (dB)	ANTENNA HEIGHT (m)	TABLE ANGLE (Degree)	RAW VALUE (dBuV)	CORRECTION FACTOR (dB/m)
1	*5720.00	112.3 PK			1.48 H	324	109.4	2.9
2	*5720.00	102.5 AV			1.48 H	324	99.6	2.9
3	#5850.00	52.8 PK	68.2	-15.4	1.48 H	328	49.5	3.3
4	11440.00	53.7 PK	74.0	-20.3	1.51 H	136	41.0	12.7
5	11440.00	40.0 AV	54.0	-14.0	1.51 H	136	27.3	12.7
6	#17160.00	51.4 PK	68.2	-16.8	1.53 H	313	35.8	15.6

ANTENNA POLARITY & TEST DISTANCE: VERTICAL AT 3 M

NO.	FREQ. (MHz)	EMISSION LEVEL (dBuV/m)	LIMIT (dBuV/m)	MARGIN (dB)	ANTENNA HEIGHT (m)	TABLE ANGLE (Degree)	RAW VALUE (dBuV)	CORRECTION FACTOR (dB/m)
1	*5720.00	114.2 PK			1.50 V	284	111.3	2.9
2	*5720.00	105.5 AV			1.50 V	284	102.6	2.9
3	#5850.00	55.2 PK	68.2	-13.0	1.50 V	284	51.9	3.3
4	11440.00	56.2 PK	74.0	-17.8	3.96 V	92	43.5	12.7
5	11440.00	42.1 AV	54.0	-11.9	3.96 V	92	29.4	12.7
6	#17160.00	54.0 PK	68.2	-14.2	1.50 V	103	38.4	15.6

REMARKS:

1. Emission Level(dBuV/m) = Raw Value(dBuV) + Correction Factor(dB/m)
2. Correction Factor(dB/m) = Antenna Factor(dB/m) + Cable Factor(dB) – Pre-Amplifier Factor(dB)
3. The other emission levels were very low against the limit.
4. Margin value = Emission Level – Limit value
5. " * ": Fundamental frequency.
6. " # ": The radiated frequency is out of the restricted band.

802.11ac (VHT20)

CHANNEL	TX Channel 52	DETECTOR FUNCTION	Peak (PK)
FREQUENCY RANGE	1GHz ~ 40GHz		Average (AV)

ANTENNA POLARITY & TEST DISTANCE: HORIZONTAL AT 3 M

NO.	FREQ. (MHz)	EMISSION LEVEL (dBuV/m)	LIMIT (dBuV/m)	MARGIN (dB)	ANTENNA HEIGHT (m)	TABLE ANGLE (Degree)	RAW VALUE (dBuV)	CORRECTION FACTOR (dB/m)
1	5150.00	53.5 PK	74.0	-20.5	1.41 H	334	50.9	2.6
2	5150.00	41.6 AV	54.0	-12.4	1.41 H	334	39.0	2.6
3	*5260.00	110.5 PK			1.41 H	334	108.4	2.1
4	*5260.00	101.8 AV			1.41 H	334	99.7	2.1
5	#10520.00	53.0 PK	68.2	-15.2	1.53 H	177	40.6	12.4
6	15780.00	59.3 PK	74.0	-14.7	1.49 H	348	47.8	11.5
7	15780.00	46.9 AV	54.0	-7.1	1.49 H	348	35.4	11.5

ANTENNA POLARITY & TEST DISTANCE: VERTICAL AT 3 M

NO.	FREQ. (MHz)	EMISSION LEVEL (dBuV/m)	LIMIT (dBuV/m)	MARGIN (dB)	ANTENNA HEIGHT (m)	TABLE ANGLE (Degree)	RAW VALUE (dBuV)	CORRECTION FACTOR (dB/m)
1	5150.00	55.2 PK	74.0	-18.8	1.66 V	244	52.6	2.6
2	5150.00	43.2 AV	54.0	-10.8	1.66 V	244	40.6	2.6
3	*5260.00	112.2 PK			1.66 V	244	110.1	2.1
4	*5260.00	103.4 AV			1.66 V	244	101.3	2.1
5	#10520.00	55.9 PK	68.2	-12.3	3.85 V	79	43.5	12.4
6	15780.00	61.2 PK	74.0	-12.8	1.87 V	130	49.7	11.5
7	15780.00	48.3 AV	54.0	-5.7	1.87 V	130	36.8	11.5

REMARKS:

- Emission Level(dBuV/m) = Raw Value(dBuV) + Correction Factor(dB/m)
- Correction Factor(dB/m) = Antenna Factor(dB/m) + Cable Factor(dB) – Pre-Amplifier Factor(dB)
- The other emission levels were very low against the limit.
- Margin value = Emission Level – Limit value
- " * ": Fundamental frequency.
- " # ": The radiated frequency is out of the restricted band.

CHANNEL	TX Channel 60	DETECTOR FUNCTION	Peak (PK)
FREQUENCY RANGE	1GHz ~ 40GHz		Average (AV)

ANTENNA POLARITY & TEST DISTANCE: HORIZONTAL AT 3 M

NO.	FREQ. (MHz)	EMISSION LEVEL (dBuV/m)	LIMIT (dBuV/m)	MARGIN (dB)	ANTENNA HEIGHT (m)	TABLE ANGLE (Degree)	RAW VALUE (dBuV)	CORRECTION FACTOR (dB/m)
1	*5300.00	110.8 PK			1.45 H	331	108.6	2.2
2	*5300.00	101.9 AV			1.45 H	331	99.7	2.2
3	5350.00	58.2 PK	74.0	-15.8	1.45 H	331	55.9	2.3
4	5350.00	46.5 AV	54.0	-7.5	1.45 H	331	44.2	2.3
5	10600.00	54.0 PK	74.0	-20.0	1.44 H	192	42.3	11.7
6	10600.00	40.4 AV	54.0	-13.6	1.44 H	192	28.7	11.7
7	15900.00	58.7 PK	74.0	-15.3	1.53 H	360	47.5	11.2
8	15900.00	46.5 AV	54.0	-7.5	1.53 H	360	35.3	11.2

ANTENNA POLARITY & TEST DISTANCE: VERTICAL AT 3 M

NO.	FREQ. (MHz)	EMISSION LEVEL (dBuV/m)	LIMIT (dBuV/m)	MARGIN (dB)	ANTENNA HEIGHT (m)	TABLE ANGLE (Degree)	RAW VALUE (dBuV)	CORRECTION FACTOR (dB/m)
1	*5300.00	112.4 PK			2.46 V	217	110.2	2.2
2	*5300.00	103.5 AV			2.46 V	217	101.3	2.2
3	5350.00	60.7 PK	74.0	-13.3	2.46 V	217	58.4	2.3
4	5350.00	48.4 AV	54.0	-5.6	2.46 V	217	46.1	2.3
5	10600.00	55.6 PK	74.0	-18.4	3.84 V	94	43.9	11.7
6	10600.00	42.7 AV	54.0	-11.3	3.84 V	94	31.0	11.7
7	15900.00	60.5 PK	74.0	-13.5	1.93 V	132	49.3	11.2
8	15900.00	47.9 AV	54.0	-6.1	1.93 V	132	36.7	11.2

REMARKS:

1. Emission Level(dBuV/m) = Raw Value(dBuV) + Correction Factor(dB/m)
2. Correction Factor(dB/m) = Antenna Factor(dB/m) + Cable Factor(dB) – Pre-Amplifier Factor(dB)
3. The other emission levels were very low against the limit.
4. Margin value = Emission Level – Limit value
5. " * ": Fundamental frequency.

CHANNEL	TX Channel 64	DETECTOR FUNCTION	Peak (PK)
FREQUENCY RANGE	1GHz ~ 40GHz		Average (AV)

ANTENNA POLARITY & TEST DISTANCE: HORIZONTAL AT 3 M

NO.	FREQ. (MHz)	EMISSION LEVEL (dBuV/m)	LIMIT (dBuV/m)	MARGIN (dB)	ANTENNA HEIGHT (m)	TABLE ANGLE (Degree)	RAW VALUE (dBuV)	CORRECTION FACTOR (dB/m)
1	*5320.00	111.2 PK			1.40 H	324	108.9	2.3
2	*5320.00	102.1 AV			1.40 H	324	99.8	2.3
3	5350.00	56.8 PK	74.0	-17.2	1.40 H	324	54.5	2.3
4	5350.00	47.6 AV	54.0	-6.4	1.40 H	324	45.3	2.3
5	5352.60	66.5 PK	74.0	-7.5	1.40 H	324	64.2	2.3
6	5352.60	50.1 AV	54.0	-3.9	1.40 H	324	47.8	2.3
7	10640.00	53.6 PK	74.0	-20.4	1.47 H	177	41.9	11.7
8	10640.00	40.1 AV	54.0	-13.9	1.47 H	177	28.4	11.7
9	15960.00	58.7 PK	74.0	-15.3	1.51 H	349	47.3	11.4
10	15960.00	46.5 AV	54.0	-7.5	1.51 H	349	35.1	11.4

ANTENNA POLARITY & TEST DISTANCE: VERTICAL AT 3 M

NO.	FREQ. (MHz)	EMISSION LEVEL (dBuV/m)	LIMIT (dBuV/m)	MARGIN (dB)	ANTENNA HEIGHT (m)	TABLE ANGLE (Degree)	RAW VALUE (dBuV)	CORRECTION FACTOR (dB/m)
1	*5320.00	112.5 PK			2.24 V	255	110.2	2.3
2	*5320.00	103.7 AV			2.24 V	255	101.4	2.3
3	5350.00	59.2 PK	74.0	-14.8	2.24 V	255	56.9	2.3
4	5350.00	50.1 AV	54.0	-3.9	2.24 V	255	47.8	2.3
5	5352.60	68.2 PK	74.0	-5.8	2.24 V	255	65.9	2.3
6	5352.60	53.8 AV	54.0	-0.2	2.24 V	255	51.5	2.3
7	10640.00	55.4 PK	74.0	-18.6	3.88 V	93	43.7	11.7
8	10640.00	42.4 AV	54.0	-11.6	3.88 V	93	30.7	11.7
9	15960.00	60.8 PK	74.0	-13.2	1.81 V	124	49.4	11.4
10	15960.00	48.2 AV	54.0	-5.8	1.81 V	124	36.8	11.4

REMARKS:

1. Emission Level(dBuV/m) = Raw Value(dBuV) + Correction Factor(dB/m)
2. Correction Factor(dB/m) = Antenna Factor(dB/m) + Cable Factor(dB) – Pre-Amplifier Factor(dB)
3. The other emission levels were very low against the limit.
4. Margin value = Emission Level – Limit value
5. " * ": Fundamental frequency.

CHANNEL	TX Channel 100	DETECTOR FUNCTION	Peak (PK)
FREQUENCY RANGE	1GHz ~ 40GHz		Average (AV)

ANTENNA POLARITY & TEST DISTANCE: HORIZONTAL AT 3 M

NO.	FREQ. (MHz)	EMISSION LEVEL (dBuV/m)	LIMIT (dBuV/m)	MARGIN (dB)	ANTENNA HEIGHT (m)	TABLE ANGLE (Degree)	RAW VALUE (dBuV)	CORRECTION FACTOR (dB/m)
1	5460.00	56.1 PK	74.0	-17.9	1.36 H	337	53.5	2.6
2	5460.00	44.3 AV	54.0	-9.7	1.36 H	337	41.7	2.6
3	#5470.00	64.5 PK	68.2	-3.7	1.36 H	337	61.9	2.6
4	*5500.00	111.4 PK			1.36 H	337	108.9	2.5
5	*5500.00	102.5 AV			1.36 H	337	100.0	2.5
6	11000.00	54.2 PK	74.0	-19.8	1.45 H	163	42.0	12.2
7	11000.00	40.5 AV	54.0	-13.5	1.45 H	163	28.3	12.2
8	#16500.00	58.2 PK	68.2	-10.0	1.49 H	358	44.5	13.7

ANTENNA POLARITY & TEST DISTANCE: VERTICAL AT 3 M

NO.	FREQ. (MHz)	EMISSION LEVEL (dBuV/m)	LIMIT (dBuV/m)	MARGIN (dB)	ANTENNA HEIGHT (m)	TABLE ANGLE (Degree)	RAW VALUE (dBuV)	CORRECTION FACTOR (dB/m)
1	5460.00	59.2 PK	74.0	-14.8	1.00 V	360	56.6	2.6
2	5460.00	47.3 AV	54.0	-6.7	1.00 V	360	44.7	2.6
3	#5470.00	67.9 PK	68.2	-0.3	1.50 V	360	65.3	2.6
4	*5500.00	112.3 PK			1.50 V	360	109.8	2.5
5	*5500.00	103.2 AV			1.50 V	360	100.7	2.5
6	11000.00	55.1 PK	74.0	-18.9	3.85 V	94	42.9	12.2
7	11000.00	42.0 AV	54.0	-12.0	3.85 V	94	29.8	12.2
8	#16500.00	61.0 PK	68.2	-7.2	1.77 V	109	47.3	13.7

REMARKS:

1. Emission Level(dBuV/m) = Raw Value(dBuV) + Correction Factor(dB/m)
2. Correction Factor(dB/m) = Antenna Factor(dB/m) + Cable Factor(dB) – Pre-Amplifier Factor(dB)
3. The other emission levels were very low against the limit.
4. Margin value = Emission Level – Limit value
5. " * ": Fundamental frequency.
6. " # ": The radiated frequency is out of the restricted band.

CHANNEL	TX Channel 116	DETECTOR FUNCTION	Peak (PK)
FREQUENCY RANGE	1GHz ~ 40GHz		Average (AV)

ANTENNA POLARITY & TEST DISTANCE: HORIZONTAL AT 3 M

NO.	FREQ. (MHz)	EMISSION LEVEL (dBuV/m)	LIMIT (dBuV/m)	MARGIN (dB)	ANTENNA HEIGHT (m)	TABLE ANGLE (Degree)	RAW VALUE (dBuV)	CORRECTION FACTOR (dB/m)
1	5460.00	54.1 PK	74.0	-19.9	1.36 H	331	51.5	2.6
2	5460.00	44.1 AV	54.0	-9.9	1.36 H	331	41.5	2.6
3	#5470.00	56.7 PK	68.2	-11.5	1.36 H	331	54.1	2.6
4	*5580.00	111.0 PK			1.36 H	331	108.2	2.8
5	*5580.00	101.7 AV			1.36 H	331	98.9	2.8
6	11160.00	53.5 PK	74.0	-20.5	1.47 H	173	41.5	12.0
7	11160.00	39.8 AV	54.0	-14.2	1.47 H	173	27.8	12.0
8	#16740.00	59.0 PK	68.2	-9.2	1.51 H	359	44.8	14.2

ANTENNA POLARITY & TEST DISTANCE: VERTICAL AT 3 M

NO.	FREQ. (MHz)	EMISSION LEVEL (dBuV/m)	LIMIT (dBuV/m)	MARGIN (dB)	ANTENNA HEIGHT (m)	TABLE ANGLE (Degree)	RAW VALUE (dBuV)	CORRECTION FACTOR (dB/m)
1	5460.00	58.2 PK	74.0	-15.8	1.57 V	360	55.6	2.6
2	5460.00	46.2 AV	54.0	-7.8	1.57 V	360	43.6	2.6
3	#5470.00	58.3 PK	68.2	-9.9	1.57 V	360	55.7	2.6
4	*5580.00	112.1 PK			1.57 V	360	109.3	2.8
5	*5580.00	103.1 AV			1.57 V	360	100.3	2.8
6	11160.00	55.7 PK	74.0	-18.3	3.86 V	93	43.7	12.0
7	11160.00	42.6 AV	54.0	-11.4	3.86 V	93	30.6	12.0
8	#16740.00	60.2 PK	68.2	-8.0	1.76 V	137	46.0	14.2

REMARKS:

1. Emission Level(dBuV/m) = Raw Value(dBuV) + Correction Factor(dB/m)
2. Correction Factor(dB/m) = Antenna Factor(dB/m) + Cable Factor(dB) – Pre-Amplifier Factor(dB)
3. The other emission levels were very low against the limit.
4. Margin value = Emission Level – Limit value
5. " * ": Fundamental frequency.
6. " # ": The radiated frequency is out of the restricted band.

CHANNEL	TX Channel 140	DETECTOR FUNCTION	Peak (PK)
FREQUENCY RANGE	1GHz ~ 40GHz		Average (AV)

ANTENNA POLARITY & TEST DISTANCE: HORIZONTAL AT 3 M

NO.	FREQ. (MHz)	EMISSION LEVEL (dBuV/m)	LIMIT (dBuV/m)	MARGIN (dB)	ANTENNA HEIGHT (m)	TABLE ANGLE (Degree)	RAW VALUE (dBuV)	CORRECTION FACTOR (dB/m)
1	*5700.00	111.2 PK			1.38 H	318	108.3	2.9
2	*5700.00	102.1 AV			1.38 H	318	99.2	2.9
3	#5725.00	64.2 PK	68.2	-4.0	1.38 H	318	61.3	2.9
4	11400.00	53.3 PK	74.0	-20.7	1.52 H	188	40.3	13.0
5	11400.00	39.6 AV	54.0	-14.4	1.52 H	188	26.6	13.0
6	#17100.00	59.1 PK	68.2	-9.1	1.57 H	360	43.0	16.1

ANTENNA POLARITY & TEST DISTANCE: VERTICAL AT 3 M

NO.	FREQ. (MHz)	EMISSION LEVEL (dBuV/m)	LIMIT (dBuV/m)	MARGIN (dB)	ANTENNA HEIGHT (m)	TABLE ANGLE (Degree)	RAW VALUE (dBuV)	CORRECTION FACTOR (dB/m)
1	*5700.00	112.5 PK			1.87 V	295	109.6	2.9
2	*5700.00	103.4 AV			1.87 V	295	100.5	2.9
3	#5725.00	68.1 PK	68.2	-0.1	1.87 V	295	65.2	2.9
4	11400.00	55.4 PK	74.0	-18.6	3.86 V	93	42.4	13.0
5	11400.00	42.4 AV	54.0	-11.6	3.86 V	93	29.4	13.0
6	#17100.00	61.0 PK	68.2	-7.2	1.78 V	139	44.9	16.1

REMARKS:

- Emission Level(dBuV/m) = Raw Value(dBuV) + Correction Factor(dB/m)
- Correction Factor(dB/m) = Antenna Factor(dB/m) + Cable Factor(dB) – Pre-Amplifier Factor(dB)
- The other emission levels were very low against the limit.
- Margin value = Emission Level – Limit value
- " * ": Fundamental frequency.
- " # ": The radiated frequency is out of the restricted band.

CHANNEL	TX Channel 144	DETECTOR FUNCTION	Peak (PK)
FREQUENCY RANGE	1GHz ~ 40GHz		Average (AV)

ANTENNA POLARITY & TEST DISTANCE: HORIZONTAL AT 3 M

NO.	FREQ. (MHz)	EMISSION LEVEL (dBuV/m)	LIMIT (dBuV/m)	MARGIN (dB)	ANTENNA HEIGHT (m)	TABLE ANGLE (Degree)	RAW VALUE (dBuV)	CORRECTION FACTOR (dB/m)
1	5460.00	51.1 PK	74.0	-22.9	1.36 H	329	48.5	2.6
2	5460.00	39.8 AV	54.0	-14.2	1.36 H	329	37.2	2.6
3	#5470.00	49.8 PK	68.2	-18.4	1.36 H	329	47.2	2.6
4	*5720.00	111.5 PK			1.36 H	329	108.6	2.9
5	*5720.00	102.1 AV			1.36 H	329	99.2	2.9
6	#5850.00	56.4 PK	68.2	-11.8	1.36 H	329	53.1	3.3
7	11440.00	54.0 PK	74.0	-20.0	1.51 H	168	41.3	12.7
8	11440.00	40.4 AV	54.0	-13.6	1.51 H	168	27.7	12.7
9	#17160.00	58.6 PK	68.2	-9.6	1.54 H	340	43.0	15.6

ANTENNA POLARITY & TEST DISTANCE: VERTICAL AT 3 M

NO.	FREQ. (MHz)	EMISSION LEVEL (dBuV/m)	LIMIT (dBuV/m)	MARGIN (dB)	ANTENNA HEIGHT (m)	TABLE ANGLE (Degree)	RAW VALUE (dBuV)	CORRECTION FACTOR (dB/m)
1	5460.00	53.5 PK	74.0	-20.5	1.70 V	294	50.9	2.6
2	5460.00	42.5 AV	54.0	-11.5	1.70 V	294	39.9	2.6
3	#5470.00	52.5 PK	68.2	-15.7	1.70 V	294	49.9	2.6
4	*5720.00	112.8 PK			1.92 V	288	109.9	2.9
5	*5720.00	103.5 AV			1.92 V	288	100.6	2.9
6	#5850.00	58.7 PK	68.2	-9.5	1.70 V	294	55.4	3.3
7	11440.00	55.4 PK	74.0	-18.6	3.82 V	109	42.7	12.7
8	11440.00	42.6 AV	54.0	-11.4	3.82 V	109	29.9	12.7
9	#17160.00	60.7 PK	68.2	-7.5	1.80 V	149	45.1	15.6

REMARKS:

1. Emission Level(dBuV/m) = Raw Value(dBuV) + Correction Factor(dB/m)
2. Correction Factor(dB/m) = Antenna Factor(dB/m) + Cable Factor(dB) – Pre-Amplifier Factor(dB)
3. The other emission levels were very low against the limit.
4. Margin value = Emission Level – Limit value
5. " * ": Fundamental frequency.
6. " # ": The radiated frequency is out of the restricted band.

802.11ac (VHT40)

CHANNEL	TX Channel 54	DETECTOR FUNCTION	Peak (PK)
FREQUENCY RANGE	1GHz ~ 40GHz		Average (AV)

ANTENNA POLARITY & TEST DISTANCE: HORIZONTAL AT 3 M

NO.	FREQ. (MHz)	EMISSION LEVEL (dBuV/m)	LIMIT (dBuV/m)	MARGIN (dB)	ANTENNA HEIGHT (m)	TABLE ANGLE (Degree)	RAW VALUE (dBuV)	CORRECTION FACTOR (dB/m)
1	5150.00	55.8 PK	74.0	-18.2	1.66 H	304	53.2	2.6
2	5150.00	43.2 AV	54.0	-10.8	1.66 H	304	40.6	2.6
3	*5270.00	108.3 PK			1.66 H	304	106.2	2.1
4	*5270.00	98.2 AV			1.66 H	304	96.1	2.1
5	5350.00	61.2 PK	74.0	-12.8	1.66 H	304	58.9	2.3
6	5350.00	46.1 AV	54.0	-7.9	1.66 H	304	43.8	2.3
7	#10540.00	53.5 PK	68.2	-14.7	1.66 H	165	41.3	12.2
8	15810.00	60.1 PK	74.0	-13.9	1.56 H	176	48.8	11.3
9	15810.00	45.4 AV	54.0	-8.6	1.56 H	176	34.1	11.3

ANTENNA POLARITY & TEST DISTANCE: VERTICAL AT 3 M

NO.	FREQ. (MHz)	EMISSION LEVEL (dBuV/m)	LIMIT (dBuV/m)	MARGIN (dB)	ANTENNA HEIGHT (m)	TABLE ANGLE (Degree)	RAW VALUE (dBuV)	CORRECTION FACTOR (dB/m)
1	5150.00	58.1 PK	74.0	-15.9	2.26 V	264	55.5	2.6
2	5150.00	46.3 AV	54.0	-7.7	2.26 V	264	43.7	2.6
3	*5270.00	109.9 PK			2.50 V	220	107.8	2.1
4	*5270.00	100.4 AV			2.50 V	220	98.3	2.1
5	5350.00	63.2 PK	74.0	-10.8	2.26 V	264	60.9	2.3
6	5350.00	49.3 AV	54.0	-4.7	2.26 V	264	47.0	2.3
7	#10540.00	55.9 PK	68.2	-12.3	3.69 V	114	43.7	12.2
8	15810.00	62.4 PK	74.0	-11.6	2.01 V	132	51.1	11.3
9	15810.00	47.9 AV	54.0	-6.1	2.01 V	132	36.6	11.3

REMARKS:

1. Emission Level(dBuV/m) = Raw Value(dBuV) + Correction Factor(dB/m)
2. Correction Factor(dB/m) = Antenna Factor(dB/m) + Cable Factor(dB) – Pre-Amplifier Factor(dB)
3. The other emission levels were very low against the limit.
4. Margin value = Emission Level – Limit value
5. " * ": Fundamental frequency.
6. " # ": The radiated frequency is out of the restricted band.

CHANNEL	TX Channel 62	DETECTOR FUNCTION	Peak (PK)
FREQUENCY RANGE	1GHz ~ 40GHz		Average (AV)

ANTENNA POLARITY & TEST DISTANCE: HORIZONTAL AT 3 M

NO.	FREQ. (MHz)	EMISSION LEVEL (dBuV/m)	LIMIT (dBuV/m)	MARGIN (dB)	ANTENNA HEIGHT (m)	TABLE ANGLE (Degree)	RAW VALUE (dBuV)	CORRECTION FACTOR (dB/m)
1	*5310.00	108.2 PK			1.64 H	301	106.0	2.2
2	*5310.00	98.3 AV			1.64 H	301	96.1	2.2
3	5350.00	66.5 PK	74.0	-7.5	1.64 H	301	64.2	2.3
4	5350.00	48.1 AV	54.0	-5.9	1.64 H	301	45.8	2.3
5	5353.80	67.5 PK	74.0	-6.5	1.64 H	301	65.1	2.4
6	5353.80	50.4 AV	54.0	-3.6	1.64 H	301	48.0	2.4
7	10620.00	53.9 PK	74.0	-20.1	1.71 H	163	42.2	11.7
8	10620.00	39.6 AV	54.0	-14.4	1.71 H	163	27.9	11.7
9	15930.00	60.1 PK	74.0	-13.9	1.59 H	166	48.9	11.2
10	15930.00	45.4 AV	54.0	-8.6	1.59 H	166	34.2	11.2

ANTENNA POLARITY & TEST DISTANCE: VERTICAL AT 3 M

NO.	FREQ. (MHz)	EMISSION LEVEL (dBuV/m)	LIMIT (dBuV/m)	MARGIN (dB)	ANTENNA HEIGHT (m)	TABLE ANGLE (Degree)	RAW VALUE (dBuV)	CORRECTION FACTOR (dB/m)
1	*5310.00	110.1 PK			2.44 V	224	107.9	2.2
2	*5310.00	100.6 AV			2.44 V	224	98.4	2.2
3	5350.00	69.0 PK	74.0	-5.0	2.44 V	224	66.7	2.3
4	5350.00	51.6 AV	54.0	-2.4	2.44 V	224	49.3	2.3
5	5353.80	70.8 PK	74.0	-3.2	2.44 V	224	68.4	2.4
6	5353.80	53.9 AV	54.0	-0.1	2.44 V	224	51.5	2.4
7	10620.00	56.3 PK	74.0	-17.7	3.71 V	125	44.6	11.7
8	10620.00	42.1 AV	54.0	-11.9	3.71 V	125	30.4	11.7
9	15930.00	62.2 PK	74.0	-11.8	1.95 V	127	51.0	11.2
10	15930.00	48.4 AV	54.0	-5.6	1.95 V	127	37.2	11.2

REMARKS:

1. Emission Level(dBuV/m) = Raw Value(dBuV) + Correction Factor(dB/m)
2. Correction Factor(dB/m) = Antenna Factor(dB/m) + Cable Factor(dB) – Pre-Amplifier Factor(dB)
3. The other emission levels were very low against the limit.
4. Margin value = Emission Level – Limit value
5. " * ": Fundamental frequency.

CHANNEL	TX Channel 102	DETECTOR FUNCTION	Peak (PK)
FREQUENCY RANGE	1GHz ~ 40GHz		Average (AV)

ANTENNA POLARITY & TEST DISTANCE: HORIZONTAL AT 3 M

NO.	FREQ. (MHz)	EMISSION LEVEL (dBuV/m)	LIMIT (dBuV/m)	MARGIN (dB)	ANTENNA HEIGHT (m)	TABLE ANGLE (Degree)	RAW VALUE (dBuV)	CORRECTION FACTOR (dB/m)
1	5460.00	61.5 PK	74.0	-12.5	1.70 H	290	58.9	2.6
2	5460.00	45.6 AV	54.0	-8.4	1.70 H	290	43.0	2.6
3	#5470.00	64.3 PK	68.2	-3.9	1.70 H	290	61.7	2.6
4	*5510.00	108.3 PK			1.70 H	290	105.8	2.5
5	*5510.00	98.3 AV			1.70 H	290	95.8	2.5
6	11020.00	53.9 PK	74.0	-20.1	1.62 H	167	41.6	12.3
7	11020.00	39.2 AV	54.0	-14.8	1.62 H	167	26.9	12.3
8	#16530.00	60.0 PK	68.2	-8.2	1.60 H	183	46.1	13.9

ANTENNA POLARITY & TEST DISTANCE: VERTICAL AT 3 M

NO.	FREQ. (MHz)	EMISSION LEVEL (dBuV/m)	LIMIT (dBuV/m)	MARGIN (dB)	ANTENNA HEIGHT (m)	TABLE ANGLE (Degree)	RAW VALUE (dBuV)	CORRECTION FACTOR (dB/m)
1	5460.00	64.7 PK	74.0	-9.3	1.50 V	359	62.1	2.6
2	5460.00	48.6 AV	54.0	-5.4	1.50 V	359	46.0	2.6
3	#5470.00	68.0 PK	68.2	-0.2	1.50 V	359	65.4	2.6
4	*5510.00	109.5 PK			1.50 V	359	107.0	2.5
5	*5510.00	99.8 AV			1.50 V	359	97.3	2.5
6	11020.00	56.0 PK	74.0	-18.0	3.71 V	127	43.7	12.3
7	11020.00	41.8 AV	54.0	-12.2	3.71 V	127	29.5	12.3
8	#16530.00	62.5 PK	68.2	-5.7	1.92 V	130	48.6	13.9

REMARKS:

1. Emission Level(dBuV/m) = Raw Value(dBuV) + Correction Factor(dB/m)
2. Correction Factor(dB/m) = Antenna Factor(dB/m) + Cable Factor(dB) – Pre-Amplifier Factor(dB)
3. The other emission levels were very low against the limit.
4. Margin value = Emission Level – Limit value
5. " * ": Fundamental frequency.
6. " # ": The radiated frequency is out of the restricted band.

CHANNEL	TX Channel 110	DETECTOR FUNCTION	Peak (PK)
FREQUENCY RANGE	1GHz ~ 40GHz		Average (AV)

ANTENNA POLARITY & TEST DISTANCE: HORIZONTAL AT 3 M

NO.	FREQ. (MHz)	EMISSION LEVEL (dBuV/m)	LIMIT (dBuV/m)	MARGIN (dB)	ANTENNA HEIGHT (m)	TABLE ANGLE (Degree)	RAW VALUE (dBuV)	CORRECTION FACTOR (dB/m)
1	5460.00	58.2 PK	74.0	-15.8	1.60 H	297	55.6	2.6
2	5460.00	44.5 AV	54.0	-9.5	1.60 H	297	41.9	2.6
3	#5470.00	64.3 PK	68.2	-3.9	1.60 H	297	61.7	2.6
4	*5550.00	109.0 PK			1.60 H	297	106.3	2.7
5	*5550.00	98.6 AV			1.60 H	297	95.9	2.7
6	#5725.00	52.8 PK	68.2	-15.4	1.60 H	297	49.9	2.9
7	11100.00	53.8 PK	74.0	-20.2	1.70 H	176	41.7	12.1
8	11100.00	39.3 AV	54.0	-14.7	1.70 H	176	27.2	12.1
9	#16650.00	60.5 PK	68.2	-7.7	1.52 H	168	46.3	14.2

ANTENNA POLARITY & TEST DISTANCE: VERTICAL AT 3 M

NO.	FREQ. (MHz)	EMISSION LEVEL (dBuV/m)	LIMIT (dBuV/m)	MARGIN (dB)	ANTENNA HEIGHT (m)	TABLE ANGLE (Degree)	RAW VALUE (dBuV)	CORRECTION FACTOR (dB/m)
1	5460.00	61.2 PK	74.0	-12.8	1.50 V	360	58.6	2.6
2	5460.00	47.5 AV	54.0	-6.5	1.50 V	360	44.9	2.6
3	#5470.00	67.9 PK	68.2	-0.3	1.50 V	360	65.3	2.6
4	*5550.00	110.1 PK			2.44 V	217	107.4	2.7
5	*5550.00	100.5 AV			2.44 V	217	97.8	2.7
6	#5725.00	55.6 PK	68.2	-12.6	1.50 V	360	52.7	2.9
7	11100.00	56.1 PK	74.0	-17.9	3.73 V	129	44.0	12.1
8	11100.00	41.8 AV	54.0	-12.2	3.73 V	129	29.7	12.1
9	#16650.00	61.7 PK	68.2	-6.5	1.94 V	121	47.5	14.2

REMARKS:

1. Emission Level(dBuV/m) = Raw Value(dBuV) + Correction Factor(dB/m)
2. Correction Factor(dB/m) = Antenna Factor(dB/m) + Cable Factor(dB) – Pre-Amplifier Factor(dB)
3. The other emission levels were very low against the limit.
4. Margin value = Emission Level – Limit value
5. " * ": Fundamental frequency.
6. " # ": The radiated frequency is out of the restricted band.

CHANNEL	TX Channel 134	DETECTOR FUNCTION	Peak (PK)
FREQUENCY RANGE	1GHz ~ 40GHz		Average (AV)

ANTENNA POLARITY & TEST DISTANCE: HORIZONTAL AT 3 M

NO.	FREQ. (MHz)	EMISSION LEVEL (dBuV/m)	LIMIT (dBuV/m)	MARGIN (dB)	ANTENNA HEIGHT (m)	TABLE ANGLE (Degree)	RAW VALUE (dBuV)	CORRECTION FACTOR (dB/m)
1	*5670.00	107.8 PK			1.61 H	300	104.9	2.9
2	*5670.00	97.9 AV			1.61 H	300	95.0	2.9
3	#5725.00	63.2 PK	68.2	-5.0	1.61 H	300	60.3	2.9
4	11340.00	53.9 PK	74.0	-20.1	1.72 H	164	41.0	12.9
5	11340.00	39.8 AV	54.0	-14.2	1.72 H	164	26.9	12.9
6	#17010.00	60.3 PK	68.2	-7.9	1.60 H	171	44.5	15.8

ANTENNA POLARITY & TEST DISTANCE: VERTICAL AT 3 M

NO.	FREQ. (MHz)	EMISSION LEVEL (dBuV/m)	LIMIT (dBuV/m)	MARGIN (dB)	ANTENNA HEIGHT (m)	TABLE ANGLE (Degree)	RAW VALUE (dBuV)	CORRECTION FACTOR (dB/m)
1	*5670.00	110.1 PK			2.43 V	220	107.2	2.9
2	*5670.00	100.4 AV			2.43 V	220	97.5	2.9
3	#5725.00	66.2 PK	68.2	-2.0	1.39 V	360	63.3	2.9
4	11340.00	56.3 PK	74.0	-17.7	3.71 V	112	43.4	12.9
5	11340.00	42.2 AV	54.0	-11.8	3.71 V	112	29.3	12.9
6	#17010.00	61.9 PK	68.2	-6.3	1.89 V	112	46.1	15.8

REMARKS:

1. Emission Level(dBuV/m) = Raw Value(dBuV) + Correction Factor(dB/m)
2. Correction Factor(dB/m) = Antenna Factor(dB/m) + Cable Factor(dB) – Pre-Amplifier Factor(dB)
3. The other emission levels were very low against the limit.
4. Margin value = Emission Level – Limit value
5. " * ": Fundamental frequency.
6. " # ": The radiated frequency is out of the restricted band.

CHANNEL	TX Channel 142	DETECTOR FUNCTION	Peak (PK)
FREQUENCY RANGE	1GHz ~ 40GHz		Average (AV)

ANTENNA POLARITY & TEST DISTANCE: HORIZONTAL AT 3 M

NO.	FREQ. (MHz)	EMISSION LEVEL (dBuV/m)	LIMIT (dBuV/m)	MARGIN (dB)	ANTENNA HEIGHT (m)	TABLE ANGLE (Degree)	RAW VALUE (dBuV)	CORRECTION FACTOR (dB/m)
1	#5470.00	52.1 PK	68.2	-16.1	1.66 H	308	49.5	2.6
2	*5710.00	108.0 PK			1.66 H	308	105.0	3.0
3	*5710.00	98.2 AV			1.66 H	308	95.2	3.0
4	#5850.00	55.7 PK	68.2	-12.5	1.66 H	308	52.4	3.3
5	11420.00	53.8 PK	74.0	-20.2	1.67 H	168	40.9	12.9
6	11420.00	40.2 AV	54.0	-13.8	1.67 H	168	27.3	12.9
7	#17130.00	60.3 PK	68.2	-7.9	1.56 H	180	44.5	15.8

ANTENNA POLARITY & TEST DISTANCE: VERTICAL AT 3 M

NO.	FREQ. (MHz)	EMISSION LEVEL (dBuV/m)	LIMIT (dBuV/m)	MARGIN (dB)	ANTENNA HEIGHT (m)	TABLE ANGLE (Degree)	RAW VALUE (dBuV)	CORRECTION FACTOR (dB/m)
1	5460.00	52.8 PK	74.0	-21.2	1.65 V	304	50.2	2.6
2	5460.00	41.8 AV	54.0	-12.2	1.65 V	304	39.2	2.6
3	#5470.00	54.9 PK	68.2	-13.3	1.65 V	304	52.3	2.6
4	*5710.00	110.4 PK			2.50 V	218	107.4	3.0
5	*5710.00	100.6 AV			2.50 V	218	97.6	3.0
6	#5850.00	58.3 PK	68.2	-9.9	1.65 V	304	55.0	3.3
7	11420.00	56.5 PK	74.0	-17.5	3.73 V	138	43.6	12.9
8	11420.00	42.4 AV	54.0	-11.6	3.73 V	138	29.5	12.9
9	#17130.00	62.1 PK	68.2	-6.1	2.00 V	124	46.3	15.8

REMARKS:

1. Emission Level(dBuV/m) = Raw Value(dBuV) + Correction Factor(dB/m)
2. Correction Factor(dB/m) = Antenna Factor(dB/m) + Cable Factor(dB) – Pre-Amplifier Factor(dB)
3. The other emission levels were very low against the limit.
4. Margin value = Emission Level – Limit value
5. " * ": Fundamental frequency.
6. " # ": The radiated frequency is out of the restricted band.

802.11ac (VHT80)

CHANNEL	TX Channel 58	DETECTOR FUNCTION	Peak (PK)
FREQUENCY RANGE	1GHz ~ 40GHz		Average (AV)

ANTENNA POLARITY & TEST DISTANCE: HORIZONTAL AT 3 M

NO.	FREQ. (MHz)	EMISSION LEVEL (dBuV/m)	LIMIT (dBuV/m)	MARGIN (dB)	ANTENNA HEIGHT (m)	TABLE ANGLE (Degree)	RAW VALUE (dBuV)	CORRECTION FACTOR (dB/m)
1	5150.00	53.6 PK	74.0	-20.4	1.68 H	296	51.0	2.6
2	5150.00	38.2 AV	54.0	-15.8	1.68 H	296	35.6	2.6
3	*5290.00	103.7 PK			1.68 H	296	101.6	2.1
4	*5290.00	94.5 AV			1.68 H	296	92.4	2.1
5	5350.00	68.7 PK	74.0	-5.3	1.68 H	296	66.4	2.3
6	5350.00	48.6 AV	54.0	-5.4	1.68 H	296	46.3	2.3
7	#10580.00	52.6 PK	68.2	-15.6	1.61 H	195	40.8	11.8
8	15870.00	57.5 PK	74.0	-16.5	1.61 H	167	46.3	11.2
9	15870.00	44.7 AV	54.0	-9.3	1.61 H	167	33.5	11.2

ANTENNA POLARITY & TEST DISTANCE: VERTICAL AT 3 M

NO.	FREQ. (MHz)	EMISSION LEVEL (dBuV/m)	LIMIT (dBuV/m)	MARGIN (dB)	ANTENNA HEIGHT (m)	TABLE ANGLE (Degree)	RAW VALUE (dBuV)	CORRECTION FACTOR (dB/m)
1	5150.00	58.4 PK	74.0	-15.6	2.22 V	252	55.8	2.6
2	5150.00	43.5 AV	54.0	-10.5	2.22 V	252	40.9	2.6
3	*5290.00	105.8 PK			2.22 V	252	103.7	2.1
4	*5290.00	97.0 AV			2.22 V	252	94.9	2.1
5	5350.00	73.5 PK	74.0	-0.5	2.22 V	252	71.2	2.3
6	5350.00	53.2 AV	54.0	-0.8	2.22 V	252	50.9	2.3
7	#10580.00	55.3 PK	68.2	-12.9	3.75 V	99	43.5	11.8
8	15870.00	60.3 PK	74.0	-13.7	1.88 V	138	49.1	11.2
9	15870.00	46.9 AV	54.0	-7.1	1.88 V	138	35.7	11.2

REMARKS:

- Emission Level(dBuV/m) = Raw Value(dBuV) + Correction Factor(dB/m)
- Correction Factor(dB/m) = Antenna Factor(dB/m) + Cable Factor(dB) – Pre-Amplifier Factor(dB)
- The other emission levels were very low against the limit.
- Margin value = Emission Level – Limit value
- " * ": Fundamental frequency.
- " # ": The radiated frequency is out of the restricted band.

CHANNEL	TX Channel 106	DETECTOR FUNCTION	Peak (PK)
FREQUENCY RANGE	1GHz ~ 40GHz		Average (AV)

ANTENNA POLARITY & TEST DISTANCE: HORIZONTAL AT 3 M

NO.	FREQ. (MHz)	EMISSION LEVEL (dBuV/m)	LIMIT (dBuV/m)	MARGIN (dB)	ANTENNA HEIGHT (m)	TABLE ANGLE (Degree)	RAW VALUE (dBuV)	CORRECTION FACTOR (dB/m)
1	5460.00	61.2 PK	74.0	-12.8	1.64 H	282	58.6	2.6
2	5460.00	47.7 AV	54.0	-6.3	1.64 H	282	45.1	2.6
3	#5470.00	63.5 PK	68.2	-4.7	1.64 H	282	60.9	2.6
4	*5530.00	103.4 PK			1.64 H	282	100.8	2.6
5	*5530.00	94.4 AV			1.64 H	282	91.8	2.6
6	#5725.00	49.9 PK	68.2	-18.3	1.64 H	282	47.0	2.9
7	11060.00	52.6 PK	74.0	-21.4	1.55 H	194	40.5	12.1
8	11060.00	39.5 AV	54.0	-14.5	1.55 H	194	27.4	12.1
9	#16590.00	57.5 PK	68.2	-10.7	1.58 H	169	43.3	14.2

ANTENNA POLARITY & TEST DISTANCE: VERTICAL AT 3 M

NO.	FREQ. (MHz)	EMISSION LEVEL (dBuV/m)	LIMIT (dBuV/m)	MARGIN (dB)	ANTENNA HEIGHT (m)	TABLE ANGLE (Degree)	RAW VALUE (dBuV)	CORRECTION FACTOR (dB/m)
1	5460.00	66.0 PK	74.0	-8.0	1.50 V	356	63.4	2.6
2	5460.00	52.9 AV	54.0	-1.1	1.50 V	356	50.3	2.6
3	#5470.00	68.1 PK	68.2	-0.1	1.50 V	356	65.5	2.6
4	*5530.00	105.1 PK			1.50 V	356	102.5	2.6
5	*5530.00	96.1 AV			1.50 V	356	93.5	2.6
6	#5725.00	54.1 PK	68.2	-14.1	1.50 V	356	51.2	2.9
7	11060.00	55.1 PK	74.0	-18.9	3.79 V	107	43.0	12.1
8	11060.00	42.5 AV	54.0	-11.5	3.79 V	107	30.4	12.1
9	#16590.00	61.1 PK	68.2	-7.1	1.93 V	118	46.9	14.2

REMARKS:

1. Emission Level(dBuV/m) = Raw Value(dBuV) + Correction Factor(dB/m)
2. Correction Factor(dB/m) = Antenna Factor(dB/m) + Cable Factor(dB) – Pre-Amplifier Factor(dB)
3. The other emission levels were very low against the limit.
4. Margin value = Emission Level – Limit value
5. " * ": Fundamental frequency.
6. " # ": The radiated frequency is out of the restricted band.

CHANNEL	TX Channel 122	DETECTOR FUNCTION	Peak (PK)
FREQUENCY RANGE	1GHz ~ 40GHz		Average (AV)

ANTENNA POLARITY & TEST DISTANCE: HORIZONTAL AT 3 M

NO.	FREQ. (MHz)	EMISSION LEVEL (dBuV/m)	LIMIT (dBuV/m)	MARGIN (dB)	ANTENNA HEIGHT (m)	TABLE ANGLE (Degree)	RAW VALUE (dBuV)	CORRECTION FACTOR (dB/m)
1	5460.00	59.4 PK	74.0	-14.6	1.68 H	288	56.8	2.6
2	5460.00	46.8 AV	54.0	-7.2	1.68 H	288	44.2	2.6
3	#5470.00	60.2 PK	68.2	-8.0	1.68 H	288	57.6	2.6
4	*5610.00	105.2 PK			1.68 H	288	102.4	2.8
5	*5610.00	96.5 AV			1.68 H	288	93.7	2.8
6	#5725.00	61.2 PK	68.2	-7.0	1.68 H	288	58.3	2.9
7	11220.00	52.7 PK	74.0	-21.3	1.53 H	202	40.4	12.3
8	11220.00	39.7 AV	54.0	-14.3	1.53 H	202	27.4	12.3
9	#16830.00	57.9 PK	68.2	-10.3	1.62 H	157	43.3	14.6

ANTENNA POLARITY & TEST DISTANCE: VERTICAL AT 3 M

NO.	FREQ. (MHz)	EMISSION LEVEL (dBuV/m)	LIMIT (dBuV/m)	MARGIN (dB)	ANTENNA HEIGHT (m)	TABLE ANGLE (Degree)	RAW VALUE (dBuV)	CORRECTION FACTOR (dB/m)
1	5460.00	64.8 PK	74.0	-9.2	1.50 V	356	62.2	2.6
2	5460.00	51.1 AV	54.0	-2.9	1.50 V	356	48.5	2.6
3	#5470.00	65.2 PK	68.2	-3.0	1.00 V	356	62.6	2.6
4	*5610.00	107.6 PK			1.50 V	356	104.8	2.8
5	*5610.00	98.4 AV			1.50 V	356	95.6	2.8
6	#5725.00	66.4 PK	68.2	-1.8	1.50 V	356	63.5	2.9
7	11220.00	55.2 PK	74.0	-18.8	3.78 V	103	42.9	12.3
8	11220.00	42.4 AV	54.0	-11.6	3.78 V	103	30.1	12.3
9	#16830.00	61.0 PK	68.2	-7.2	1.94 V	111	46.4	14.6

REMARKS:

1. Emission Level(dBuV/m) = Raw Value(dBuV) + Correction Factor(dB/m)
2. Correction Factor(dB/m) = Antenna Factor(dB/m) + Cable Factor(dB) – Pre-Amplifier Factor(dB)
3. The other emission levels were very low against the limit.
4. Margin value = Emission Level – Limit value
5. " * ": Fundamental frequency.
6. " # ": The radiated frequency is out of the restricted band.

CHANNEL	TX Channel 138	DETECTOR FUNCTION	Peak (PK)
FREQUENCY RANGE	1GHz ~ 40GHz		Average (AV)

ANTENNA POLARITY & TEST DISTANCE: HORIZONTAL AT 3 M

NO.	FREQ. (MHz)	EMISSION LEVEL (dBuV/m)	LIMIT (dBuV/m)	MARGIN (dB)	ANTENNA HEIGHT (m)	TABLE ANGLE (Degree)	RAW VALUE (dBuV)	CORRECTION FACTOR (dB/m)
1	5460.00	59.6 PK	74.0	-14.4	1.64 H	291	57.0	2.6
2	5460.00	47.2 AV	54.0	-6.8	1.64 H	291	44.6	2.6
3	#5470.00	61.4 PK	68.2	-6.8	1.64 H	291	58.8	2.6
4	*5690.00	105.2 PK			1.64 H	291	102.3	2.9
5	*5690.00	96.6 AV			1.64 H	291	93.7	2.9
6	#5850.00	60.6 PK	68.2	-7.6	1.64 H	291	57.3	3.3
7	11380.00	52.6 PK	74.0	-21.4	1.57 H	210	39.7	12.9
8	11380.00	39.9 AV	54.0	-14.1	1.57 H	210	27.0	12.9
9	#17070.00	58.1 PK	68.2	-10.1	1.57 H	172	42.0	16.1

ANTENNA POLARITY & TEST DISTANCE: VERTICAL AT 3 M

NO.	FREQ. (MHz)	EMISSION LEVEL (dBuV/m)	LIMIT (dBuV/m)	MARGIN (dB)	ANTENNA HEIGHT (m)	TABLE ANGLE (Degree)	RAW VALUE (dBuV)	CORRECTION FACTOR (dB/m)
1	5460.00	65.3 PK	74.0	-8.7	1.48 V	349	62.7	2.6
2	5460.00	51.5 AV	54.0	-2.5	1.48 V	349	48.9	2.6
3	#5470.00	66.2 PK	68.2	-2.0	1.49 V	346	63.6	2.6
4	*5690.00	107.8 PK			1.52 V	344	104.9	2.9
5	*5690.00	98.7 AV			1.52 V	344	95.8	2.9
6	#5850.00	65.6 PK	68.2	-2.6	1.00 V	346	62.3	3.3
7	11380.00	54.7 PK	74.0	-19.3	3.83 V	103	41.8	12.9
8	11380.00	42.0 AV	54.0	-12.0	3.83 V	103	29.1	12.9
9	#17070.00	60.6 PK	68.2	-7.6	1.91 V	122	44.5	16.1

REMARKS:

1. Emission Level(dBuV/m) = Raw Value(dBuV) + Correction Factor(dB/m)
2. Correction Factor(dB/m) = Antenna Factor(dB/m) + Cable Factor(dB) – Pre-Amplifier Factor(dB)
3. The other emission levels were very low against the limit.
4. Margin value = Emission Level – Limit value
5. " * ": Fundamental frequency.
6. " # ": The radiated frequency is out of the restricted band.

Below 1GHz Data:
802.11ac (VHT40)

CHANNEL	TX Channel 54	DETECTOR FUNCTION	Quasi-Peak (QP)
FREQUENCY RANGE	9kHz ~ 1GHz		

ANTENNA POLARITY & TEST DISTANCE: HORIZONTAL AT 3 M

NO.	FREQ. (MHz)	EMISSION LEVEL (dBuV/m)	LIMIT (dBuV/m)	MARGIN (dB)	ANTENNA HEIGHT (m)	TABLE ANGLE (Degree)	RAW VALUE (dBuV)	CORRECTION FACTOR (dB/m)
1	83.37	35.8 QP	40.0	-4.2	2.00 H	122	49.1	-13.3
2	203.28	38.4 QP	43.5	-5.1	2.00 H	263	49.3	-10.9
3	281.19	39.7 QP	46.0	-6.3	1.00 H	64	47.3	-7.6
4	625.02	38.7 QP	46.0	-7.3	1.00 H	146	37.8	0.9
5	750.12	40.8 QP	46.0	-5.2	1.00 H	164	37.5	3.3
6	874.46	39.7 QP	46.0	-6.3	1.50 H	322	35.2	4.5

REMARKS:

1. Emission Level(dBuV/m) = Raw Value(dBuV) + Correction Factor(dB/m)
2. Correction Factor(dB/m) = Antenna Factor(dB/m) + Cable Factor(dB) – Pre-Amplifier Factor(dB)
3. Margin value = Emission Level – Limit value
4. The emission levels were very low against the limit of frequency range 9kHz~30MHz: the amplitude of spurious emissions attenuated more than 20 dB below the permissible value to be report.

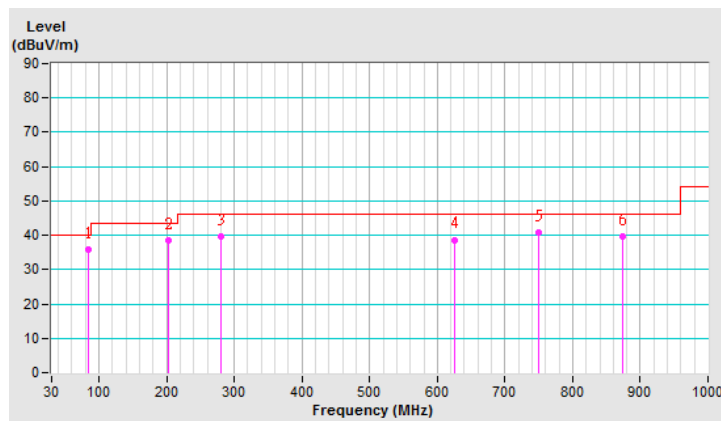

CHANNEL	TX Channel 54	DETECTOR FUNCTION	Quasi-Peak (QP)
FREQUENCY RANGE	9kHz ~ 1GHz		

ANTENNA POLARITY & TEST DISTANCE: VERTICAL AT 3 M

NO.	FREQ. (MHz)	EMISSION LEVEL (dBuV/m)	LIMIT (dBuV/m)	MARGIN (dB)	ANTENNA HEIGHT (m)	TABLE ANGLE (Degree)	RAW VALUE (dBuV)	CORRECTION FACTOR (dB/m)
1	30.29	34.9 QP	40.0	-5.1	1.00 V	265	44.0	-9.1
2	60.46	36.2 QP	40.0	-3.8	1.00 V	208	44.7	-8.5
3	82.96	35.1 QP	40.0	-4.9	1.50 V	266	48.4	-13.3
4	279.83	39.8 QP	46.0	-6.2	1.00 V	218	47.5	-7.7
5	746.09	38.6 QP	46.0	-7.4	1.50 V	88	35.4	3.2
6	873.57	40.9 QP	46.0	-5.1	1.00 V	191	36.4	4.5

REMARKS:

1. Emission Level(dBuV/m) = Raw Value(dBuV) + Correction Factor(dB/m)
2. Correction Factor(dB/m) = Antenna Factor(dB/m) + Cable Factor(dB) – Pre-Amplifier Factor(dB)
3. Margin value = Emission Level – Limit value
4. The emission levels were very low against the limit of frequency range 9kHz~30MHz: the amplitude of spurious emissions attenuated more than 20 dB below the permissible value to be report.

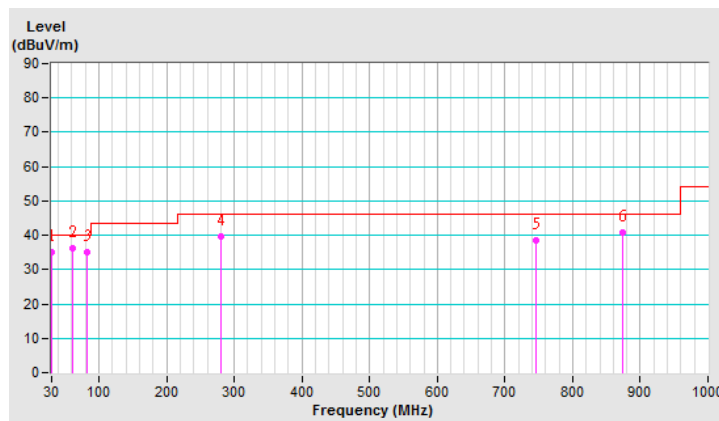

4.2 Conducted Emission Measurement

4.2.1 Limits of Conducted Emission Measurement

Frequency (MHz)	Conducted Limit (dBuV)	
	Quasi-peak	Average
0.15 - 0.5	66 - 56	56 - 46
0.50 - 5.0	56	46
5.0 - 30.0	60	50

Note: 1. The lower limit shall apply at the transition frequencies.

2. The limit decreases in line with the logarithm of the frequency in the range of 0.15 to 0.50MHz.

4.2.2 Test Instruments

DESCRIPTION & MANUFACTURER	MODEL NO.	SERIAL NO.	CALIBRATED DATE	CALIBRATED UNTIL
Test Receiver R&S	ESCS 30	847124/029	Nov. 01, 2017	Oct. 31, 2018
Line-Impedance Stabilization Network (for EUT) R&S	ESH3-Z5	848773/004	Nov. 15, 2017	Nov. 14, 2018
Line-Impedance Stabilization Network (for Peripheral) R&S	ENV216	100072	June 04, 2018	June 03, 2019
50 ohms Terminator	N/A	EMC-02	Sep. 22, 2017	Sep. 21, 2018
RF Cable	5D-FB	COCCAB-001	Sep. 29, 2017	Sep. 28, 2018
Fixed attenuator EMCI	STI02-2200-10	003	Mar. 16, 2018	Mar. 15, 2019
Software BVADT	BVADT_Cond_ V7.3.7.4	NA	NA	NA

Note:

1. The calibration interval of the above test instruments are 12 months and the calibrations are traceable to NML/ROC and NIST/USA.
2. The test was performed in Conduction 1.
- 3 Tested Date: Aug. 23, 2018

4.2.3 Test Procedure

- The EUT was placed 0.4 meters from the conducting wall of the shielded room with EUT being connected to the power mains through a line impedance stabilization network (LISN). Other support units were connected to the power mains through another LISN. The two LISNs provide 50 ohm/ 50uH of coupling impedance for the measuring instrument.
- Both lines of the power mains connected to the EUT were checked for maximum conducted interference.
- The frequency range from 150kHz to 30MHz was searched. Emission levels under (Limit - 20dB) was not recorded.

Note: All modes of operation were investigated and the worst-case emissions are reported.

4.2.4 Deviation from Test Standard

No deviation.

4.2.5 Test Setup

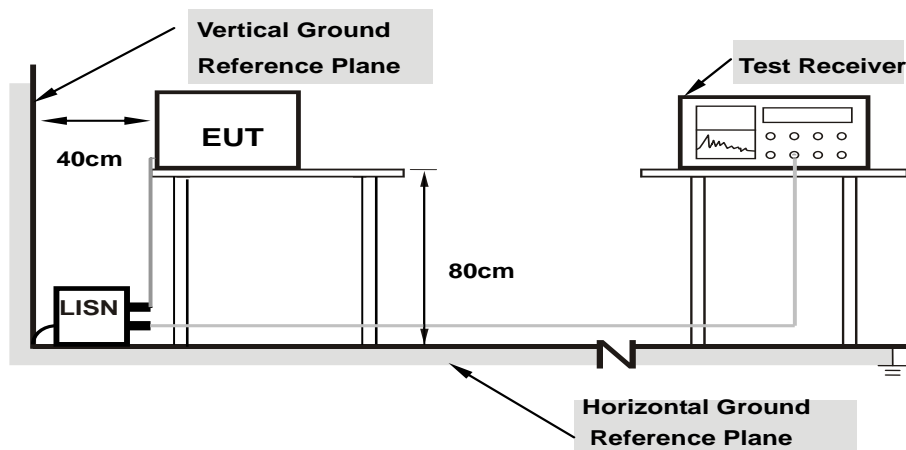

Note: 1.Support units were connected to second LISN.

For the actual test configuration, please refer to the attached file (Test Setup Photo).

4.2.6 EUT Operating Condition

Same as 4.1.6.

4.2.7 Test Results (Mode 1)

CDD Mode

Phase	Line (L)	Detector Function	Quasi-Peak (QP) / Average (AV)
-------	----------	-------------------	--------------------------------

No	Freq. [MHz]	Corr.	Reading Value		Emission Level		Limit		Margin	
		Factor (dB)	[dB (uV)]		[dB (uV)]		[dB (uV)]		(dB)	
		Q.P.	AV.	Q.P.	AV.	Q.P.	AV.	Q.P.	AV.	
1	0.15000	10.05	38.07	29.97	48.12	40.02	66.00	56.00	-17.88	-15.98
2	0.23984	10.08	38.97	36.31	49.05	46.39	62.10	52.10	-13.05	-5.71
3	0.96641	10.17	22.43	15.08	32.60	25.25	56.00	46.00	-23.40	-20.75
4	3.38672	10.30	25.07	18.05	35.37	28.35	56.00	46.00	-20.63	-17.65
5	10.06250	10.71	14.50	8.85	25.21	19.56	60.00	50.00	-34.79	-30.44
6	14.44922	11.02	12.09	4.11	23.11	15.13	60.00	50.00	-36.89	-34.87

Remarks:

1. Q.P. and AV. are abbreviations of quasi-peak and average individually.
2. The emission levels of other frequencies were very low against the limit.
3. Margin value = Emission level – Limit value
4. Correction factor = Insertion loss + Cable loss
5. Emission Level = Correction Factor + Reading Value

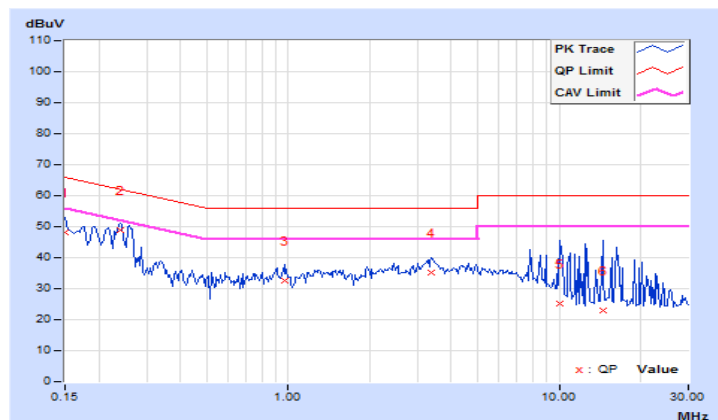

Phase	Neutral (N)	Detector Function	Quasi-Peak (QP) / Average (AV)
-------	-------------	-------------------	--------------------------------

No	Freq.	Corr.	Reading Value		Emission Level		Limit		Margin	
	[MHz]	Factor	[dB (uV)]		[dB (uV)]		[dB (uV)]		(dB)	
		(dB)	Q.P.	AV.	Q.P.	AV.	Q.P.	AV.	Q.P.	AV.
1	0.15000	9.95	38.26	29.46	48.21	39.41	66.00	56.00	-17.79	-16.59
2	0.24375	9.98	35.17	27.99	45.15	37.97	61.97	51.97	-16.82	-14.00
3	0.53672	10.02	19.92	13.08	29.94	23.10	56.00	46.00	-26.06	-22.90
4	3.27734	10.16	26.10	18.76	36.26	28.92	56.00	46.00	-19.74	-17.08
5	8.37891	10.45	19.20	13.84	29.65	24.29	60.00	50.00	-30.35	-25.71
6	13.44531	10.76	13.95	3.40	24.71	14.16	60.00	50.00	-35.29	-35.84

Remarks:

1. Q.P. and AV. are abbreviations of quasi-peak and average individually.
2. The emission levels of other frequencies were very low against the limit.
3. Margin value = Emission level – Limit value
4. Correction factor = Insertion loss + Cable loss
5. Emission Level = Correction Factor + Reading Value

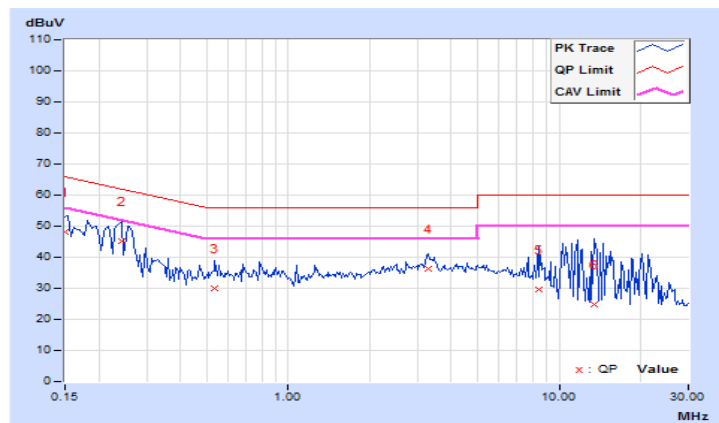

4.2.8 Test Results (Mode 2)

CDD Mode

Phase	Line (L)	Detector Function	Quasi-Peak (QP) / Average (AV)
-------	----------	-------------------	--------------------------------

No	Freq. [MHz]	Corr.	Reading Value		Emission Level		Limit		Margin	
		Factor (dB)	[dB (uV)]		[dB (uV)]		[dB (uV)]		(dB)	
			Q.P.	AV.	Q.P.	AV.	Q.P.	AV.	Q.P.	AV.
1	0.15000	10.05	42.64	26.58	52.69	36.63	66.00	56.00	-13.31	-19.37
2	0.36484	10.11	44.61	29.59	54.72	39.70	58.62	48.62	-3.90	-8.92
3	0.50000	10.13	35.37	17.89	45.50	28.02	56.00	46.00	-10.50	-17.98
4	0.58359	10.14	31.24	14.58	41.38	24.72	56.00	46.00	-14.62	-21.28
5	2.30859	10.24	12.86	6.79	23.10	17.03	56.00	46.00	-32.90	-28.97
6	7.13672	10.53	11.75	7.19	22.28	17.72	60.00	50.00	-37.72	-32.28

Remarks:

1. Q.P. and AV. are abbreviations of quasi-peak and average individually.
2. The emission levels of other frequencies were very low against the limit.
3. Margin value = Emission level – Limit value
4. Correction factor = Insertion loss + Cable loss
5. Emission Level = Correction Factor + Reading Value

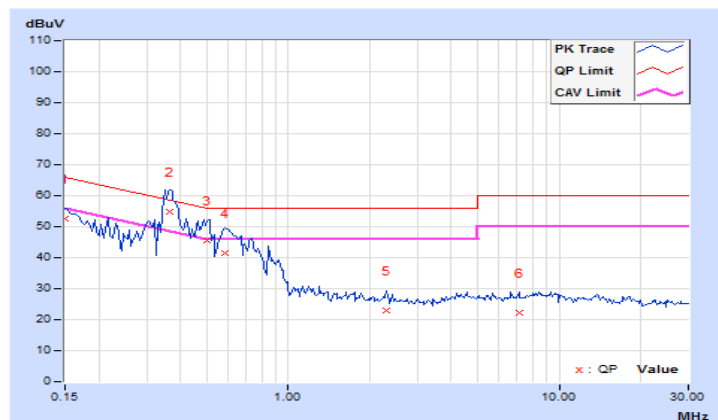

Phase	Neutral (N)	Detector Function	Quasi-Peak (QP) / Average (AV)
-------	-------------	-------------------	--------------------------------

No	Freq. [MHz]	Corr. Factor	Reading Value [dB (uV)]		Emission Level [dB (uV)]		Limit [dB (uV)]		Margin (dB)	
		(dB)	Q.P.	AV.	Q.P.	AV.	Q.P.	AV.	Q.P.	AV.
	1	0.15000	9.95	42.64	26.58	52.59	36.53	66.00	56.00	-13.41
2	0.36484	10.01	44.61	29.59	54.62	39.60	58.62	48.62	-4.00	-9.02
3	0.50000	10.02	35.37	17.89	45.39	27.91	56.00	46.00	-10.61	-18.09
4	0.58359	10.03	31.24	14.58	41.27	24.61	56.00	46.00	-14.73	-21.39
5	2.30859	10.11	12.86	6.79	22.97	16.90	56.00	46.00	-33.03	-29.10
6	7.13672	10.37	11.75	7.19	22.12	17.56	60.00	50.00	-37.88	-32.44

Remarks:

1. Q.P. and AV. are abbreviations of quasi-peak and average individually.
2. The emission levels of other frequencies were very low against the limit.
3. Margin value = Emission level – Limit value
4. Correction factor = Insertion loss + Cable loss
5. Emission Level = Correction Factor + Reading Value

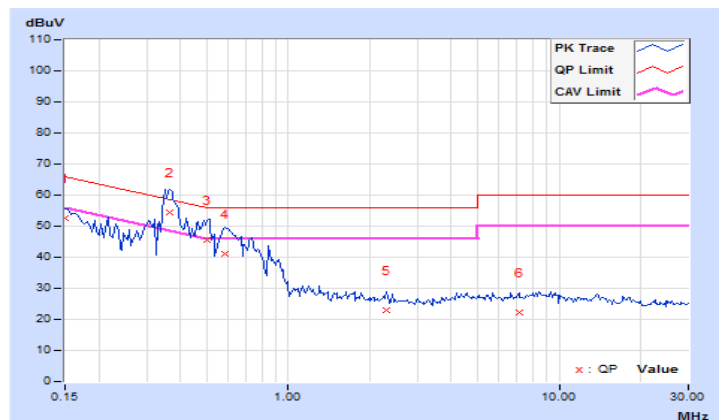

4.3 Transmit Power Measurement

4.3.1 Limits of Transmit Power Measurement

Operation Band	EUT Category		Limit
U-NII-1		Outdoor Access Point	1 Watt (30 dBm) (Max. e.i.r.p \leq 125mW(21 dBm) at any elevation angle above 30 degrees as measured from the horizon)
		Fixed point-to-point Access Point	1 Watt (30 dBm)
		Indoor Access Point	1 Watt (30 dBm)
		Client device	250mW (24 dBm)
U-NII-2A		√	250mW (24 dBm) or 11 dBm+10 log B*
U-NII-2C		√	250mW (24 dBm) or 11 dBm+10 log B*
U-NII-3		√	1 Watt (30 dBm)

*B is the 26 dB emission bandwidth in megahertz

Per KDB 662911 Method of conducted output power measurement on IEEE 802.11 devices,

Array Gain = 0 dB (i.e., no array gain) for $N_{ANT} \leq 4$;

Array Gain = 0 dB (i.e., no array gain) for channel widths ≥ 40 MHz for any N_{ANT} ;

Array Gain = $5 \log(N_{ANT}/N_{SS})$ dB or 3 dB, whichever is less for 20-MHz channel widths with $N_{ANT} \geq 5$.

For power measurements on all other devices: Array Gain = $10 \log(N_{ANT}/N_{SS})$ dB.

4.3.2 Test Setup

FOR POWER OUTPUT MEASUREMENT

For channel straddling 5725MHz:

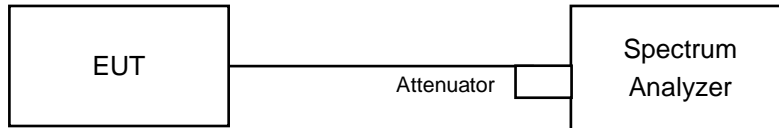

For other channels:

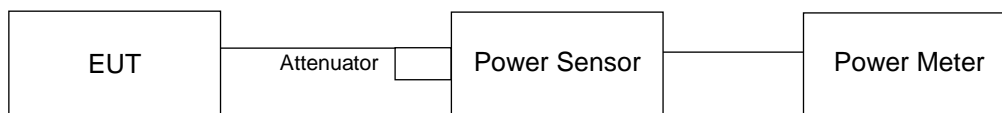

FOR 26dB OCCUPIED BANDWIDTH

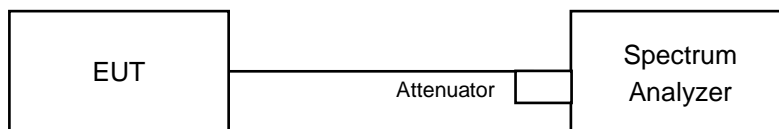

4.3.3 Test Instruments

Refer to section 4.1.2 to get information of above instrument.

4.3.4 Test Procedure

FOR POWER OUTPUT MEASUREMENT

For other channels:

Method PM is used to perform output power measurement, trigger and gating function of wide band power meter is enabled to measure max output power of TX on burst. Duty factor is not added to measured value.

For channel straddling 5725MHz:

For 802.11ac (VHT20)

Follow FCC KDB 789033 UNII test procedure:

Method SA-1

1. Set span to encompass the entire emission bandwidth (EBW) of the signal.
2. Set RBW =1MHz.
3. Set the VBW $\geq 3 \times$ RBW.
4. Number of points in sweep ≥ 2 Span / RBW.
5. Sweep time = auto.
6. Set trigger to free run (duty cycle ≥ 98 percent)
7. Detector = RMS.
8. Trace average at least 100 traces in power averaging mode
9. Compute power by integrating the spectrum across the 26 dB EBW of the signal.

For 802.11a, 802.11ac (VHT40), 802.11ac (VHT80)

Follow FCC KDB 789033 UNII test procedure:

Method SA-2

1. Set span to encompass the emission bandwidth (EBW) of the signal.
2. Set RBW =1MHz.
3. Set the VBW $\geq 3 \times$ RBW.
4. Number of points in sweep ≥ 2 Span / RBW.
5. Sweep time = auto.
6. Detector = RMS.
7. Trace average at least 100 traces in power averaging mode
8. Compute power by integrating the spectrum across the 26 dB EBW of the signal.
9. Duty factor need added to measured value (duty cycle < 98 percent).

FOR 26dB OCCUPIED BANDWIDTH

1. Set RBW = approximately 1% of the emission bandwidth.
2. Set the VBW > RBW.
3. Detector = Peak.
4. Trace mode = max hold.
5. Measure the maximum width of the emission that is 26 dB down from the peak of the emission. Compare this with the RBW setting of the analyzer. Readjust RBW and repeat measurement as needed until the RBW/EBW ratio is approximately 1%.

4.3.5 Deviation from Test Standard

No deviation.

4.3.6 EUT Operating Condition

The software provided by client to enable the EUT under transmission condition continuously at lowest, middle and highest channel frequencies individually.

4.3.7 Test Results

CDD Mode

802.11a

POWER OUTPUT

Chan.	Chan. Freq. (MHz)	Maximum Conducted Power (dBm)				Total Power (mW)	Total Power (dBm)	Limit (dBm)	Pass / Fail
		Chain 0	Chain 1	Chain 2	Chain 3				
52	5260	17.56	17.46	17.97	17.99	238.347	23.77	24.00	Pass
60	5300	17.69	17.38	18.01	17.96	239.209	23.79	24.00	Pass
64	5320	17.56	17.18	17.64	17.69	226.081	23.54	24.00	Pass
100	5500	17.25	17.19	17.02	17.36	210.248	23.23	24.00	Pass
116	5580	17.28	17.11	17.23	17.52	214.199	23.31	24.00	Pass
140	5700	17.32	17.15	17.18	17.43	213.406	23.29	24.00	Pass
*144 (U-NII-2C Band)	5720	12.13	12.09	12.99	11.78	73.981	18.69	23.19	Pass
*144 (U-NII-3 Band)	5720	6.09	5.51	7.44	6.13	18.93	12.77	30.00	Pass

Note: * Test was performed in accordance with Measurement follow FCC KDB 789033 UNII test procedure Method SA-2 and use spectrum analyzer test.

The Total Power for the straddle channel:

Chan.	Chan. Freq. (MHz)	Average Power (mW)	Average Power (dBm)
144	5720	92.911	19.68

Note: The total power was calculated through formula and record the value for reference only.

26dB OCCUPIED BANDWIDTH

Channel	Frequency (MHz)	26dBc Bandwidth (MHz)			
		Chain 0	Chain 1	Chain 2	Chain 3
52	5260	22.92	23.63	23.35	23.47
60	5300	23.08	23.56	23.58	23.41
64	5320	23.01	23.47	23.44	23.49
100	5500	23.35	23.66	23.82	23.46
116	5580	23.27	23.62	23.68	23.57
140	5700	23.13	23.51	23.35	23.60
144 (U-NII-2C Band)	5720	16.87	16.93	16.64	16.57

Note: For U-NII-2A, U-NII-2C Band output power limitation is determined based on 26dBc bandwidth

Power Limit = 11dBm + 10logB < U-NII-2A, U-NII-2C >			
Channel Number	Freq.(MHz)	Min. B(MHz)	Determined Conducted Limit (dBm)
52	5260	22.92	24.6 > 24
60	5300	23.08	24.63 > 24
64	5320	23.01	24.61 > 24
100	5500	23.35	24.68 > 24
116	5580	23.27	24.66 > 24
140	5700	23.13	24.64 > 24
144 (U-NII-2C Band)	5720	16.57	23.19 < 24

802.11ac (VHT20)
POWER OUTPUT

Chan.	Chan. Freq. (MHz)	Maximum Conducted Power (dBm)				Total Power (mW)	Total Power (dBm)	Limit (dBm)	Pass / Fail
		Chain 0	Chain 1	Chain 2	Chain 3				
52	5260	17.49	17.41	17.76	17.89	232.408	23.66	24.00	Pass
60	5300	17.49	17.21	17.48	17.87	225.918	23.54	24.00	Pass
64	5320	17.48	17.19	17.56	17.87	226.587	23.55	24.00	Pass
100	5500	17.89	17.99	17.79	17.98	247.392	23.93	24.00	Pass
116	5580	17.32	17.42	17.36	17.29	217.189	23.37	24.00	Pass
140	5700	17.45	17.52	17.56	17.48	225.076	23.52	24.00	Pass
*144 (U-NII-2C Band)	5720	14.58	13.77	14.56	13.58	103.91	20.17	23.36	Pass
*144 (U-NII-3 Band)	5720	9.15	7.85	9.47	7.88	29.306	14.67	30.00	Pass

Note: * Test was performed in accordance with Measurement follow FCC KDB 789033 UNII test procedure Method SA-1 and use spectrum analyzer test.

The Total Power for the straddle channel:

Chan.	Chan. Freq. (MHz)	Average Power (mW)	Average Power (dBm)
144	5720	133.216	21.25

Note: The total power was calculated through formula and record the value for reference only.

26dB OCCUPIED BANDWIDTH

Channel	Frequency (MHz)	26dBc Bandwidth (MHz)			
		Chain 0	Chain 1	Chain 2	Chain 3
52	5260	24.79	25.02	24.28	24.00
60	5300	24.97	25.12	24.32	24.00
64	5320	24.82	25.15	24.17	24.05
100	5500	24.64	25.05	24.19	24.28
116	5580	24.92	25.08	24.53	23.96
140	5700	24.90	25.16	23.97	24.06
144 (U-NII-2C Band)	5720	17.70	17.78	17.52	17.24

Note: For U-NII-2A, U-NII-2C Band output power limitation is determined based on 26dBc bandwidth

Power Limit = 11dBm + 10logB < U-NII-2A, U-NII-2C >			
Channel Number	Freq.(MHz)	Min. B(MHz)	Determined Conducted Limit (dBm)
52	5260	24.00	24.8 > 24
60	5300	24.00	24.8 > 24
64	5320	24.05	24.81 > 24
100	5500	24.19	24.83 > 24
116	5580	23.96	24.79 > 24
140	5700	23.97	24.79 > 24
144 (U-NII-2C Band)	5720	17.24	23.36 < 24

802.11ac (VHT40)
POWER OUTPUT

Chan.	Chan. Freq. (MHz)	Maximum Conducted Power (dBm)				Total Power (mW)	Total Power (dBm)	Limit (dBm)	Pass / Fail
		Chain 0	Chain 1	Chain 2	Chain 3				
54	5270	17.86	17.74	17.83	18.24	247.878	23.94	24.00	Pass
62	5310	17.84	17.38	17.89	17.77	236.875	23.75	24.00	Pass
102	5510	17.78	17.81	17.62	17.94	240.414	23.81	24.00	Pass
110	5550	17.38	17.53	17.59	17.89	230.256	23.62	24.00	Pass
134	5670	17.93	18.02	17.69	17.65	242.433	23.85	24.00	Pass
*142 (U-NII-2C Band)	5710	14.37	14.59	14.42	13.23	108.177	20.34	24.00	Pass
*142 (U-NII-3 Band)	5710	4.57	5.26	5.08	3.72	12.173	10.85	30.00	Pass

Note: * Test was performed in accordance with Measurement follow FCC KDB 789033 UNII test procedure Method SA-2 and use spectrum analyzer test.

The Total Power for the straddle channel:

Chan.	Chan. Freq. (MHz)	Average Power (mW)	Average Power (dBm)
142	5710	120.35	20.8

Note: The total power was calculated through formula and record the value for reference only.

26dB OCCUPIED BANDWIDTH

Channel	Frequency (MHz)	26dBc Bandwidth (MHz)			
		Chain 0	Chain 1	Chain 2	Chain 3
54	5270	44.62	44.41	44.51	46.87
62	5310	44.47	44.20	44.39	44.15
102	5510	46.74	45.00	44.46	43.85
110	5550	44.39	44.34	44.48	43.95
134	5670	48.01	44.98	46.17	44.15
142 (U-NII-2C Band)	5710	37.31	37.29	37.13	37.08

Note: For U-NII-2A, U-NII-2C Band output power limitation is determined based on 26dBc bandwidth

Power Limit = 11dBm + 10logB < U-NII-2A, U-NII-2C >			
Channel Number	Freq.(MHz)	Min. B(MHz)	Determined Conducted Limit (dBm)
54	5270	44.41	27.47 > 24
62	5310	44.15	27.44 > 24
102	5510	43.85	27.41 > 24
110	5550	43.95	27.42 > 24
134	5670	44.15	27.44 > 24
142 (U-NII-2C Band)	5710	37.08	26.69 > 24

802.11ac (VHT80)

POWER OUTPUT

Chan.	Chan. Freq. (MHz)	Maximum Conducted Power (dBm)				Total Power (mW)	Total Power (dBm)	Limit (dBm)	Pass / Fail
		Chain 0	Chain 1	Chain 2	Chain 3				
58	5290	15.66	15.52	15.90	16.03	151.45	21.80	24.00	Pass
106	5530	15.78	15.79	15.96	16.18	156.716	21.95	24.00	Pass
122	5610	17.87	17.81	17.67	17.87	241.344	23.83	24.00	Pass
*138 (U-NII-2C Band)	5690	14.27	13.82	14.56	14.38	112.636	20.52	24.00	Pass
*138 (U-NII-3 Band)	5690	0.42	0.73	1.46	1.00	5.213	7.17	30.00	Pass

Note: * Test was performed in accordance with Measurement follow FCC KDB 789033 UNII test procedure Method SA-2 and use spectrum analyzer test.

The Total Power for the straddle channel:

Chan.	Chan. Freq. (MHz)	Average Power (mW)	Average Power (dBm)
138	5690	117.849	20.71

Note: The total power was calculated through formula and record the value for reference only.

26dB OCCUPIED BANDWIDTH

Channel	Frequency (MHz)	26dBc Bandwidth (MHz)			
		Chain 0	Chain 1	Chain 2	Chain 3
58	5290	83.73	81.43	83.76	83.47
106	5530	84.10	81.15	83.62	83.82
122	5610	94.97	84.87	96.10	87.10
138 (U-NII-2C Band)	5690	78.83	76.29	87.81	76.39

Note: For U-NII-2A, U-NII-2C Band output power limitation is determined based on 26dBc bandwidth

Power Limit = 11dBm + 10logB < U-NII-2A, U-NII-2C >			
Channel Number	Freq.(MHz)	Min. B(MHz)	Determined Conducted Limit (dBm)
58	5290	81.43	30.1 > 24
106	5530	81.15	30.09 > 24
122	5610	84.87	30.28 > 24
138 (U-NII-2C Band)	5690	76.29	29.82 > 24

Beamforming Mode

802.11ac (VHT20)

POWER OUTPUT

Chan.	Chan. Freq. (MHz)	Maximum Conducted Power (dBm)				Total Power (mW)	Total Power (dBm)	Limit (dBm)	Pass / Fail
		Chain 0	Chain 1	Chain 2	Chain 3				
52	5260	17.49	17.41	17.76	17.89	232.408	23.66	24.00	Pass
60	5300	17.49	17.21	17.48	17.87	225.918	23.54	24.00	Pass
64	5320	17.48	17.19	17.56	17.87	226.587	23.55	24.00	Pass
100	5500	17.89	17.99	17.79	17.98	247.392	23.93	24.00	Pass
116	5580	17.32	17.42	17.36	17.29	217.189	23.37	24.00	Pass
140	5700	17.45	17.52	17.56	17.48	225.076	23.52	24.00	Pass
*144 (U-NII-2C Band)	5720	14.58	13.77	14.56	13.58	103.91	20.17	23.36	Pass
*144 (U-NII-3 Band)	5720	9.15	7.85	9.47	7.88	29.306	14.67	30.00	Pass

Note: * Test was performed in accordance with Measurement follow FCC KDB 789033 UNII test procedure Method SA-1 and use spectrum analyzer test.

1. The directional gain is 3.56dBi < 6dBi, so the power limit shall not be reduced.

The Total Power for the straddle channel:

Chan.	Chan. Freq. (MHz)	Average Power (mW)	Average Power (dBm)
144	5720	133.216	21.25

Note: The total power was calculated through formula and record the value for reference only.

26dB OCCUPIED BANDWIDTH

Channel	Frequency (MHz)	26dBc Bandwidth (MHz)			
		Chain 0	Chain 1	Chain 2	Chain 3
52	5260	24.79	25.02	24.28	24.00
60	5300	24.97	25.12	24.32	24.00
64	5320	24.82	25.15	24.17	24.05
100	5500	24.64	25.05	24.19	24.28
116	5580	24.92	25.08	24.53	23.96
140	5700	24.90	25.16	23.97	24.06
144 (U-NII-2C Band)	5720	17.70	17.78	17.52	17.24

Note: For U-NII-2A, U-NII-2C Band output power limitation is determined based on 26dBc bandwidth

Power Limit = 11dBm + 10logB < U-NII-2A, U-NII-2C >			
Channel Number	Freq.(MHz)	Min. B(MHz)	Determined Conducted Limit (dBm)
52	5260	24.00	24.8 > 24
60	5300	24.00	24.8 > 24
64	5320	24.05	24.81 > 24
100	5500	24.19	24.83 > 24
116	5580	23.96	24.79 > 24
140	5700	23.97	24.79 > 24
144 (U-NII-2C Band)	5720	17.24	23.36 < 24

802.11ac (VHT40)
POWER OUTPUT

Chan.	Chan. Freq. (MHz)	Maximum Conducted Power (dBm)				Total Power (mW)	Total Power (dBm)	Limit (dBm)	Pass / Fail
		Chain 0	Chain 1	Chain 2	Chain 3				
54	5270	17.86	17.74	17.83	18.24	247.878	23.94	24.00	Pass
62	5310	17.84	17.38	17.89	17.77	236.875	23.75	24.00	Pass
102	5510	17.78	17.81	17.62	17.94	240.414	23.81	24.00	Pass
110	5550	17.38	17.53	17.59	17.89	230.256	23.62	24.00	Pass
134	5670	17.93	18.02	17.69	17.65	242.433	23.85	24.00	Pass
*142 (U-NII-2C Band)	5710	14.37	14.59	14.42	13.23	108.177	20.34	24.00	Pass
*142 (U-NII-3 Band)	5710	4.57	5.26	5.08	3.72	12.173	10.85	30.00	Pass

Note: * Test was performed in accordance with Measurement follow FCC KDB 789033 UNII test procedure Method SA-2 and use spectrum analyzer test.

1. The directional gain is 3.56dBi < 6dBi, so the power limit shall not be reduced.

The Total Power for the straddle channel:

Chan.	Chan. Freq. (MHz)	Average Power (mW)	Average Power (dBm)
142	5710	120.35	20.8

Note: The total power was calculated through formula and record the value for reference only.

26dB OCCUPIED BANDWIDTH

Channel	Frequency (MHz)	26dBc Bandwidth (MHz)			
		Chain 0	Chain 1	Chain 2	Chain 3
54	5270	44.62	44.41	44.51	46.87
62	5310	44.47	44.20	44.39	44.15
102	5510	46.74	45.00	44.46	43.85
110	5550	44.39	44.34	44.48	43.95
134	5670	48.01	44.98	46.17	44.15
142 (U-NII-2C Band)	5710	37.31	37.29	37.13	37.08

Note: For U-NII-2A, U-NII-2C Band output power limitation is determined based on 26dBc bandwidth

Power Limit = 11dBm + 10logB < U-NII-2A, U-NII-2C >			
Channel Number	Freq.(MHz)	Min. B(MHz)	Determined Conducted Limit (dBm)
54	5270	44.41	27.47 > 24
62	5310	44.15	27.44 > 24
102	5510	43.85	27.41 > 24
110	5550	43.95	27.42 > 24
134	5670	44.15	27.44 > 24
142 (U-NII-2C Band)	5710	37.08	26.69 > 24

802.11ac (VHT80)

POWER OUTPUT

Chan.	Chan. Freq. (MHz)	Maximum Conducted Power (dBm)				Total Power (mW)	Total Power (dBm)	Limit (dBm)	Pass / Fail
		Chain 0	Chain 1	Chain 2	Chain 3				
58	5290	15.66	15.52	15.90	16.03	151.45	21.80	24.00	Pass
106	5530	15.78	15.79	15.96	16.18	156.716	21.95	24.00	Pass
122	5610	17.87	17.81	17.67	17.87	241.344	23.83	24.00	Pass
*138 (U-NII-2C Band)	5690	14.27	13.82	14.56	14.38	112.636	20.52	24.00	Pass
*138 (U-NII-3 Band)	5690	0.42	0.73	1.46	1.00	5.213	7.17	30.00	Pass

Note: * Test was performed in accordance with Measurement follow FCC KDB 789033 UNII test procedure Method SA-2 and use spectrum analyzer test.

1. The directional gain is 3.56dBi < 6dBi, so the power limit shall not be reduced.

The Total Power for the straddle channel:

Chan.	Chan. Freq. (MHz)	Average Power (mW)	Average Power (dBm)
138	5690	117.849	20.71

Note: The total power was calculated through formula and record the value for reference only.

26dB OCCUPIED BANDWIDTH

Channel	Frequency (MHz)	26dBc Bandwidth (MHz)			
		Chain 0	Chain 1	Chain 2	Chain 3
58	5290	83.73	81.43	83.76	83.47
106	5530	84.10	81.15	83.62	83.82
122	5610	94.97	84.87	96.10	87.10
138 (U-NII-2C Band)	5690	78.83	76.29	87.81	76.39

Note: For U-NII-2A, U-NII-2C Band output power limitation is determined based on 26dBc bandwidth

Power Limit = 11dBm + 10logB < U-NII-2A, U-NII-2C >			
Channel Number	Freq.(MHz)	Min. B(MHz)	Determined Conducted Limit (dBm)
58	5290	81.43	30.1 > 24
106	5530	81.15	30.09 > 24
122	5610	84.87	30.28 > 24
138 (U-NII-2C Band)	5690	76.29	29.82 > 24

SDM Mode

802.11ac (VHT20)

POWER OUTPUT

Chan.	Chan. Freq. (MHz)	Maximum Conducted Power (dBm)				Total Power (mW)	Total Power (dBm)	Limit (dBm)	Pass / Fail
		Chain 0	Chain 1	Chain 2	Chain 3				
52	5260	17.49	17.41	17.76	17.89	232.408	23.66	24.00	Pass
60	5300	17.49	17.21	17.48	17.87	225.918	23.54	24.00	Pass
64	5320	17.48	17.19	17.56	17.87	226.587	23.55	24.00	Pass
100	5500	17.89	17.99	17.79	17.98	247.392	23.93	24.00	Pass
116	5580	17.32	17.42	17.36	17.29	217.189	23.37	24.00	Pass
140	5700	17.45	17.52	17.56	17.48	225.076	23.52	24.00	Pass
*144 (U-NII-2C Band)	5720	14.58	13.77	14.56	13.58	103.91	20.17	23.36	Pass
*144 (U-NII-3 Band)	5720	9.15	7.85	9.47	7.88	29.306	14.67	30.00	Pass

Note: * Test was performed in accordance with Measurement follow FCC KDB 789033 UNII test procedure Method SA-1 and use spectrum analyzer test.

The Total Power for the straddle channel:

Chan.	Chan. Freq. (MHz)	Average Power (mW)	Average Power (dBm)
144	5720	133.216	21.25

Note: The total power was calculated through formula and record the value for reference only.

26dB OCCUPIED BANDWIDTH

Channel	Frequency (MHz)	26dBc Bandwidth (MHz)			
		Chain 0	Chain 1	Chain 2	Chain 3
52	5260	24.79	25.02	24.28	24.00
60	5300	24.97	25.12	24.32	24.00
64	5320	24.82	25.15	24.17	24.05
100	5500	24.64	25.05	24.19	24.28
116	5580	24.92	25.08	24.53	23.96
140	5700	24.90	25.16	23.97	24.06
144 (U-NII-2C Band)	5720	17.70	17.78	17.52	17.24

Note: For U-NII-2A, U-NII-2C Band output power limitation is determined based on 26dBc bandwidth

Power Limit = 11dBm + 10logB < U-NII-2A, U-NII-2C >			
Channel Number	Freq.(MHz)	Min. B(MHz)	Determined Conducted Limit (dBm)
52	5260	24.00	24.8 > 24
60	5300	24.00	24.8 > 24
64	5320	24.05	24.81 > 24
100	5500	24.19	24.83 > 24
116	5580	23.96	24.79 > 24
140	5700	23.97	24.79 > 24
144 (U-NII-2C Band)	5720	17.24	23.36 < 24

802.11ac (VHT40)
POWER OUTPUT

Chan.	Chan. Freq. (MHz)	Maximum Conducted Power (dBm)				Total Power (mW)	Total Power (dBm)	Limit (dBm)	Pass / Fail
		Chain 0	Chain 1	Chain 2	Chain 3				
54	5270	17.86	17.74	17.83	18.24	247.878	23.94	24.00	Pass
62	5310	17.84	17.38	17.89	17.77	236.875	23.75	24.00	Pass
102	5510	17.78	17.81	17.62	17.94	240.414	23.81	24.00	Pass
110	5550	17.38	17.53	17.59	17.89	230.256	23.62	24.00	Pass
134	5670	17.93	18.02	17.69	17.65	242.433	23.85	24.00	Pass
*142 (U-NII-2C Band)	5710	14.37	14.59	14.42	13.23	108.177	20.34	24.00	Pass
*142 (U-NII-3 Band)	5710	4.57	5.26	5.08	3.72	12.173	10.85	30.00	Pass

Note: * Test was performed in accordance with Measurement follow FCC KDB 789033 UNII test procedure Method SA-2 and use spectrum analyzer test.

The Total Power for the straddle channel:

Chan.	Chan. Freq. (MHz)	Average Power (mW)	Average Power (dBm)
142	5710	120.35	20.8

Note: The total power was calculated through formula and record the value for reference only.

26dB OCCUPIED BANDWIDTH

Channel	Frequency (MHz)	26dBc Bandwidth (MHz)			
		Chain 0	Chain 1	Chain 2	Chain 3
54	5270	44.62	44.41	44.51	46.87
62	5310	44.47	44.20	44.39	44.15
102	5510	46.74	45.00	44.46	43.85
110	5550	44.39	44.34	44.48	43.95
134	5670	48.01	44.98	46.17	44.15
142 (U-NII-2C Band)	5710	37.31	37.29	37.13	37.08

Note: For U-NII-2A, U-NII-2C Band output power limitation is determined based on 26dBc bandwidth

Power Limit = 11dBm + 10logB < U-NII-2A, U-NII-2C >			
Channel Number	Freq.(MHz)	Min. B(MHz)	Determined Conducted Limit (dBm)
54	5270	44.41	27.47 > 24
62	5310	44.15	27.44 > 24
102	5510	43.85	27.41 > 24
110	5550	43.95	27.42 > 24
134	5670	44.15	27.44 > 24
142 (U-NII-2C Band)	5710	37.08	26.69 > 24

802.11ac (VHT80)

POWER OUTPUT

Chan.	Chan. Freq. (MHz)	Maximum Conducted Power (dBm)				Total Power (mW)	Total Power (dBm)	Limit (dBm)	Pass / Fail
		Chain 0	Chain 1	Chain 2	Chain 3				
58	5290	16.65	16.62	16.78	17.02	190.151	22.79	24.00	Pass
106	5530	15.78	15.79	15.96	16.18	156.716	21.95	24.00	Pass
122	5610	17.87	17.81	17.67	17.87	241.344	23.83	24.00	Pass
*138 (U-NII-2C Band)	5690	14.27	13.82	14.56	14.38	112.636	20.52	24.00	Pass
*138 (U-NII-3 Band)	5690	0.42	0.73	1.46	1.00	5.213	7.17	30.00	Pass

Note: * Test was performed in accordance with Measurement follow FCC KDB 789033 UNII test procedure Method SA-2 and use spectrum analyzer test.

The Total Power for the straddle channel:

Chan.	Chan. Freq. (MHz)	Average Power (mW)	Average Power (dBm)
138	5690	117.849	20.71

Note: The total power was calculated through formula and record the value for reference only.

26dB OCCUPIED BANDWIDTH

Channel	Frequency (MHz)	26dBc Bandwidth (MHz)			
		Chain 0	Chain 1	Chain 2	Chain 3
58	5290	83.73	81.43	83.76	83.47
106	5530	84.10	81.15	83.62	83.82
122	5610	94.97	84.87	96.10	87.10
138 (U-NII-2C Band)	5690	78.83	76.29	87.81	76.39

Note: For U-NII-2A, U-NII-2C Band output power limitation is determined based on 26dBc bandwidth

Power Limit = 11dBm + 10logB < U-NII-2A, U-NII-2C >			
Channel Number	Freq.(MHz)	Min. B(MHz)	Determined Conducted Limit (dBm)
58	5290	81.43	30.1 > 24
106	5530	81.15	30.09 > 24
122	5610	84.87	30.28 > 24
138 (U-NII-2C Band)	5690	76.29	29.82 > 24

Spectrum Plot of Worst Value

802.11a_Chain 3 / CH144 (U-NII-2C)

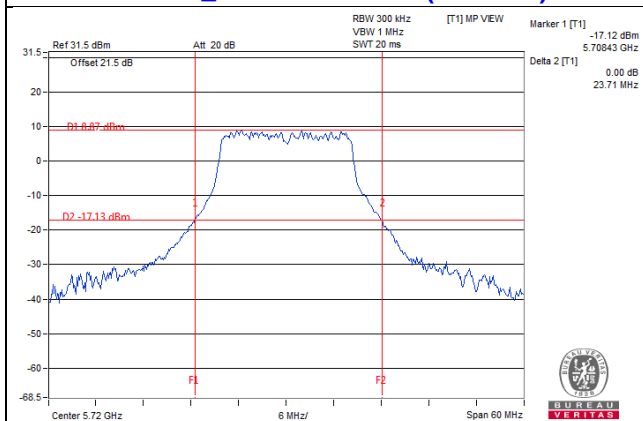

802.11ac (VHT20)_Chain 3 / CH144 (U-NII-2C)

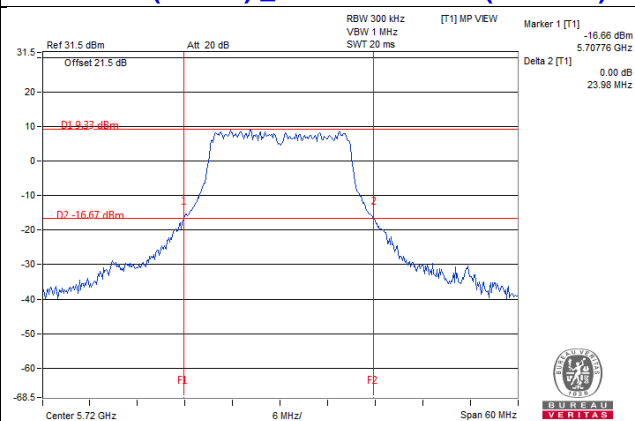

802.11ac (VHT40)_Chain 3 / CH142 (U-NII-2C)

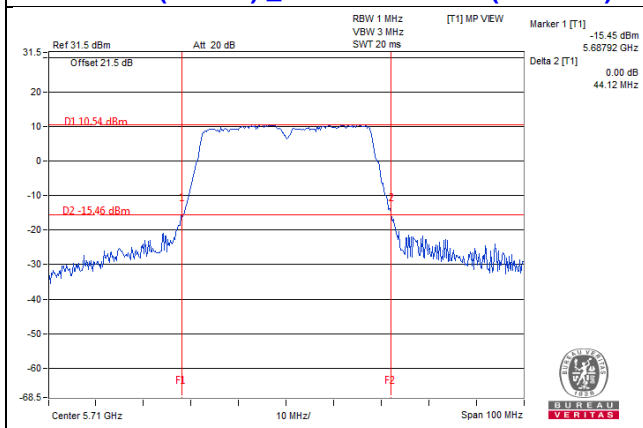

802.11ac (VHT80)_Chain 1 / CH138 (U-NII-2C)

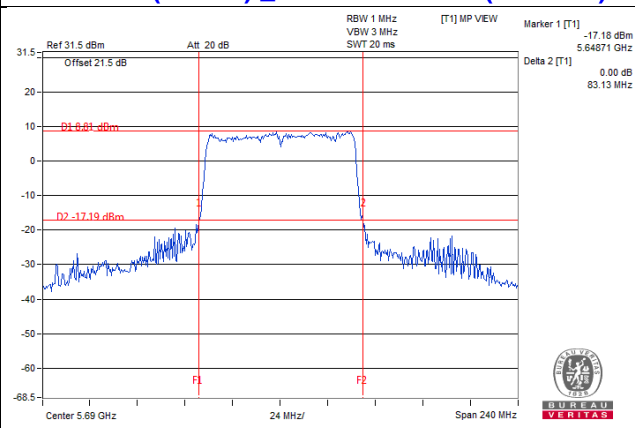

Note:

- For CH144 (U-NII-2C) = 5725MHz - Marker 1
- For CH142 (U-NII-2C) = 5725MHz - Marker 1
- For CH138 (U-NII-2C) = 5725MHz - Marker 1

4.4 Occupied Bandwidth Measurement

4.4.1 Test Setup

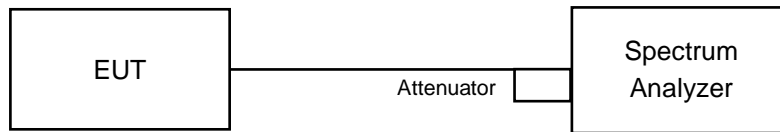

4.4.2 Test Instruments

Refer to section 4.1.2 to get information of above instrument.

4.4.3 Test Procedure

The transmitter output was connected to the spectrum analyzer through an attenuator. The bandwidth of the fundamental frequency was measured by spectrum analyzer with resolution bandwidth in the range of 1% to 5% of the anticipated emission bandwidth, and a video bandwidth at least 3x the resolution bandwidth and set the detector to SAMPLE. The width of a frequency band such that, below the lower and above the upper frequency limits, the mean powers emitted are each equal to a specified percentage 0.5 %of the total mean power of a given emission.

4.4.4 Test Results

CDD Mode

802.11a

Channel	Channel Frequency (MHz)	Occupied Bandwidth (MHz)			
		Chain 0	Chain 1	Chain 2	Chain 3
52	5260	16.92	16.92	17.04	17.04
60	5300	17.04	16.92	16.92	16.92
64	5320	16.92	16.92	16.80	17.04
100	5500	16.92	17.04	16.92	17.04
116	5580	16.80	17.04	16.80	17.04
140	5700	16.80	16.92	16.80	17.04
144 (U-NII-2C Band)	5720	13.52	13.64	13.52	13.52
144 (U-NII-3 Band)	5720	3.40	3.40	3.40	3.40

802.11ac (VHT20)

Channel	Channel Frequency (MHz)	Occupied Bandwidth (MHz)			
		Chain 0	Chain 1	Chain 2	Chain 3
52	5260	18.12	18.00	18.12	18.12
60	5300	18.12	18.24	18.00	18.00
64	5320	18.24	18.12	17.88	18.00
100	5500	18.24	18.00	18.12	18.12
116	5580	18.24	18.12	18.12	18.00
140	5700	18.00	18.24	18.12	18.12
144 (U-NII-2C Band)	5720	14.12	14.24	14.00	14.12
144 (U-NII-3 Band)	5720	4.00	3.88	4.00	4.00

802.11ac (VHT40)

Channel	Channel Frequency (MHz)	Occupied Bandwidth (MHz)			
		Chain 0	Chain 1	Chain 2	Chain 3
54	5270	36.96	36.96	36.72	36.72
62	5310	36.96	36.72	36.72	36.72
102	5510	36.96	36.72	37.20	36.96
110	5550	36.96	36.72	36.72	36.72
134	5670	36.72	36.96	36.72	36.72
142 (U-NII-2C Band)	5710	33.60	33.40	33.40	33.40
142 (U-NII-3 Band)	5710	3.20	3.40	3.40	3.40

802.11ac (VHT80)

Channel	Channel Frequency (MHz)	Occupied Bandwidth (MHz)			
		Chain 0	Chain 1	Chain 2	Chain 3
58	5290	75.36	75.36	75.36	75.84
106	5530	75.36	75.36	75.84	75.84
122	5610	75.84	75.36	75.36	75.36
138 (U-NII-2C Band)	5690	72.92	72.44	72.92	72.92
138 (U-NII-3 Band)	5690	2.44	2.92	2.44	2.44

Spectrum Plot of Max Value

802.11a_Chain 0 / CH60

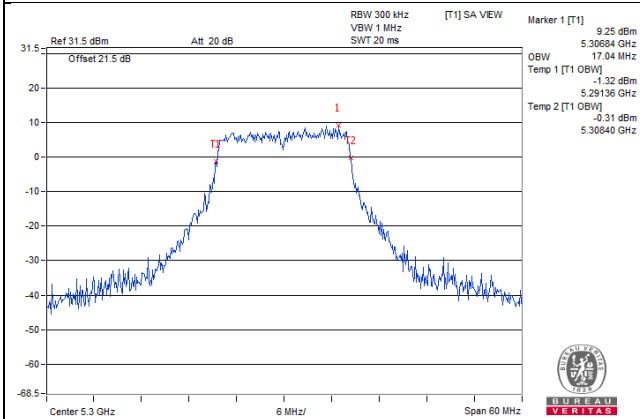

802.11ac (VHT20)_Chain 0 / CH64

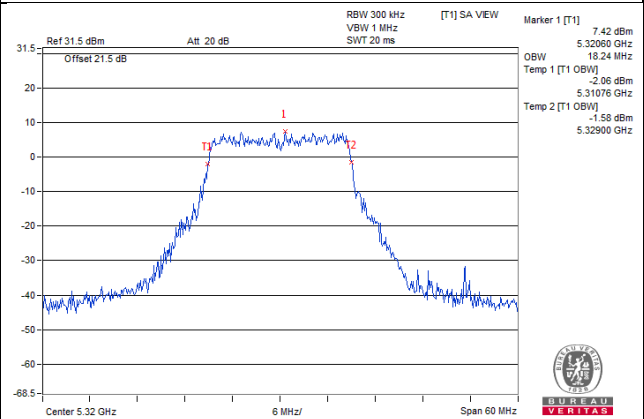

802.11ac (VHT40)_Chain 2 / CH102

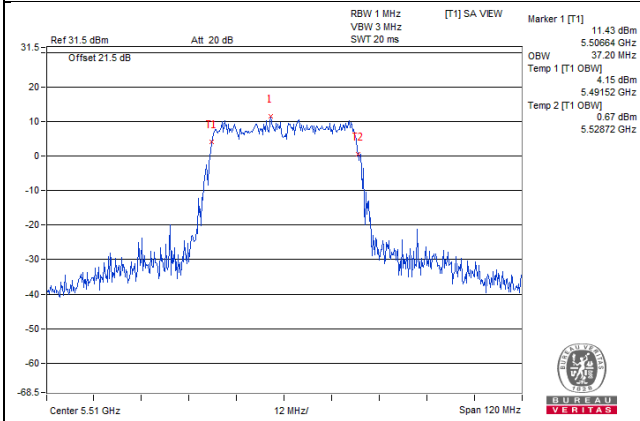

802.11ac (VHT80)_Chain 0 / CH122

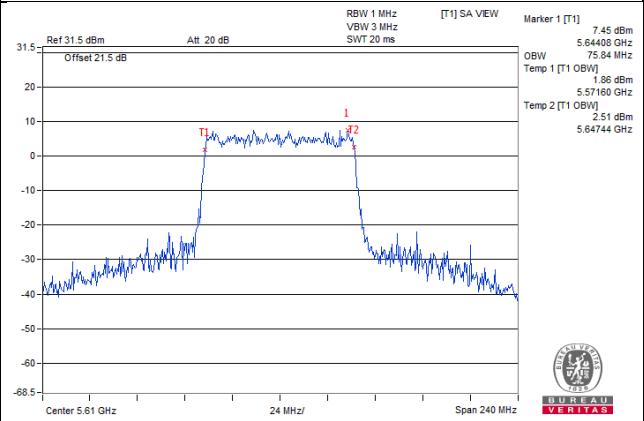

4.5 Peak Power Spectral Density Measurement

4.5.1 Limits of Peak Power Spectral Density Measurement

Operation Band	EUT Category		Limit
U-NII-1		Outdoor Access Point	17dBm/ MHz
		Fixed point-to-point Access Point	
		Indoor Access Point	
		Client device	11dBm/ MHz
U-NII-2A		√	11dBm/ MHz
U-NII-2C		√	11dBm/ MHz
U-NII-3		√	30dBm/ 500kHz

4.5.2 Test Setup

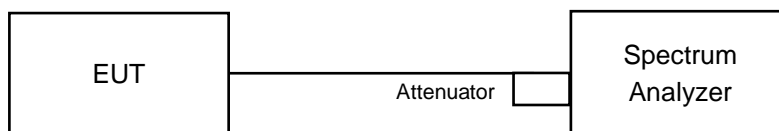

4.5.3 Test Instruments

Refer to section 4.1.2 to get information of above instrument.

4.5.4 Test Procedure

For 802.11ac (VHT20)

Using method SA-1

1. Set span to encompass the entire emission bandwidth (EBW) of the signal.
2. Set RBW = 1 MHz, Set VBW ≥ 3 MHz, Detector = RMS
3. Sweep time = auto, trigger set to “free run”.
4. Trace average at least 100 traces in power averaging mode.
5. Record the max value

For 802.11a, 802.11ac (VHT40), 802.11ac (VHT80)

Using method SA-2

1. Set span to encompass the entire emission bandwidth (EBW) of the signal.
2. Set RBW = 1 MHz, Set VBW ≥ 3 MHz, Detector = RMS
3. Sweep time = auto, trigger set to “free run”.
4. Trace average at least 100 traces in power averaging mode.
5. Record the max value and add 10 log (1/duty cycle)

4.5.5 Deviation from Test Standard

No deviation.

4.5.6 EUT Operating Condition

Same as Item 4.3.6.

4.5.7 Test Results

CDD Mode

For U-NII-2A, U-NII-2C:

802.11a

Chan.	Chan. Freq. (MHz)	PSD W/O Duty Factor (dBm/MHz)				Duty Factor (dB)	Total PSD With Duty Factor (dBm/MHz)	MAX. Limit (dBm/MHz)	Pass / Fail
		Chain 0	Chain 1	Chain 2	Chain 3				
52	5260	3.87	4.18	3.81	3.99	0.40	10.38	11	Pass
60	5300	4.09	3.82	3.62	4.31	0.40	10.39	11	Pass
64	5320	3.46	3.09	2.51	3.97	0.40	9.71	11	Pass
100	5500	-1.87	3.14	2.57	3.69	0.40	8.76	11	Pass
116	5580	3.80	3.41	3.75	4.01	0.40	10.17	11	Pass
140	5700	2.72	2.99	2.90	3.26	0.40	9.39	11	Pass
144 (U-NII-2C Band)	5720	1.62	3.44	3.13	2.57	0.40	9.16	11	Pass

- Note: 1. Method a) of power density measurement of KDB 662911 is using for calculating total power density. Total power density is summing entire spectra across corresponding frequency bins on the various outputs by computer.
2. The directional gain = 3.56dBi < 6dBi, so the power density limit shall not be reduced.
3. Refer to section 3.3 for duty cycle spectrum plot.

802.11ac (VHT20)

Chan.	Chan. Freq. (MHz)	PSD (dBm/MHz)				Total Power Density (dBm/MHz)	MAX. Limit (dBm/MHz)	Pass / Fail
		Chain 0	Chain 1	Chain 2	Chain 3			
52	5260	4.35	3.10	4.11	3.72	9.87	11	Pass
60	5300	4.10	3.35	3.33	3.80	9.68	11	Pass
64	5320	3.16	3.34	3.23	4.12	9.50	11	Pass
100	5500	3.43	3.67	4.75	4.32	10.09	11	Pass
116	5580	4.01	2.93	4.32	3.13	9.66	11	Pass
140	5700	2.93	4.03	3.33	3.74	9.55	11	Pass
144 (U-NII-2C Band)	5720	4.18	3.77	4.16	3.47	9.93	11	Pass

- Note: 1. Method a) of power density measurement of KDB 662911 is using for calculating total power density. Total power density is summing entire spectra across corresponding frequency bins on the various outputs by computer.
2. The directional gain = 3.56dBi < 6dBi, so the power density limit shall not be reduced.

802.11ac (VHT40)

Chan.	Chan. Freq. (MHz)	PSD W/O Duty Factor (dBm/MHz)				Duty Factor (dB)	Total PSD With Duty Factor (dBm/MHz)	MAX. Limit (dBm/MHz)	Pass / Fail
		Chain 0	Chain 1	Chain 2	Chain 3				
54	5270	-0.03	-0.04	1.68	1.76	0.14	7.09	11	Pass
62	5310	0.60	0.65	0.47	0.95	0.14	6.83	11	Pass
102	5510	1.33	1.10	1.06	1.28	0.14	7.35	11	Pass
110	5550	0.33	0.68	0.64	0.47	0.14	6.69	11	Pass
134	5670	0.99	1.05	1.38	1.57	0.14	7.41	11	Pass
142 (U-NII-2C Band)	5710	0.35	1.09	0.78	-0.06	0.14	6.72	11	Pass

- Note: 1. Method a) of power density measurement of KDB 662911 is using for calculating total power density. Total power density is summing entire spectra across corresponding frequency bins on the various outputs by computer.
2. The directional gain = 3.56dBi < 6dBi, so the power density limit shall not be reduced.
3. Refer to section 3.3 for duty cycle spectrum plot.

802.11ac (VHT80)

Chan.	Chan. Freq. (MHz)	PSD W/O Duty Factor (dBm/MHz)				Duty Factor (dB)	Total PSD With Duty Factor (dBm/MHz)	MAX. Limit (dBm/MHz)	Pass / Fail
		Chain 0	Chain 1	Chain 2	Chain 3				
58	5290	-3.33	-4.13	-4.10	-3.18	0.23	2.59	11	Pass
106	5530	-4.11	-3.83	-2.65	-3.68	0.23	2.72	11	Pass
122	5610	-1.65	-1.72	-1.75	-1.07	0.23	4.71	11	Pass
138 (U-NII-2C Band)	5690	-2.88	-2.01	-1.34	-1.23	0.23	4.43	11	Pass

- Note: 1. Method a) of power density measurement of KDB 662911 is using for calculating total power density. Total power density is summing entire spectra across corresponding frequency bins on the various outputs by computer.
2. The directional gain = 3.56dBi < 6dBi, so the power density limit shall not be reduced.
3. Refer to section 3.3 for duty cycle spectrum plot.

Spectrum Plot of Worst Value

802.11a_Chain 3 / CH60

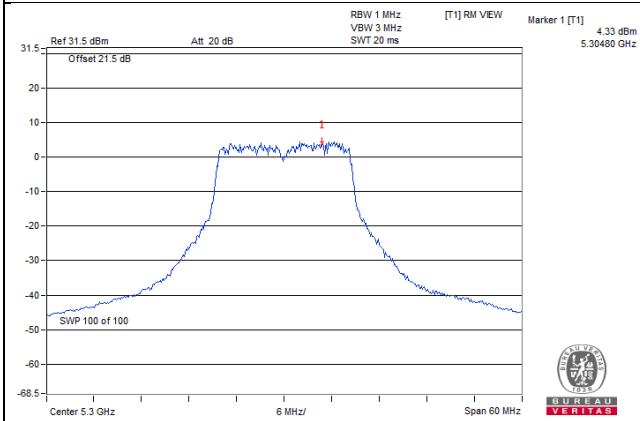

802.11ac (VHT20)_Chain 2 / CH100

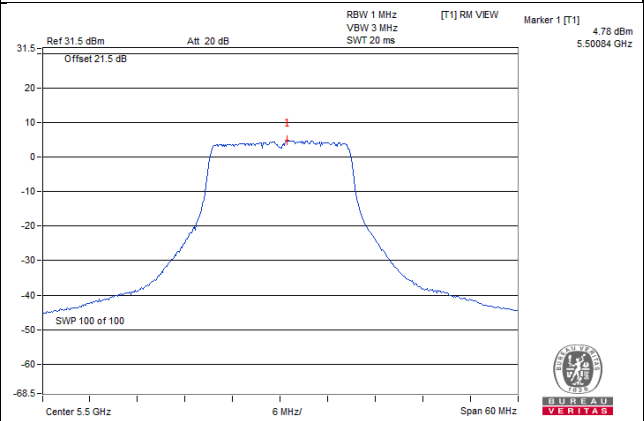

802.11ac (VHT40)_Chain 3 / CH54

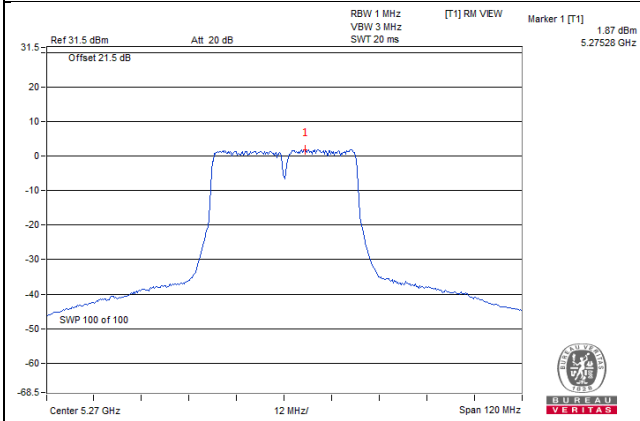

802.11ac (VHT80)_Chain 3 / CH122

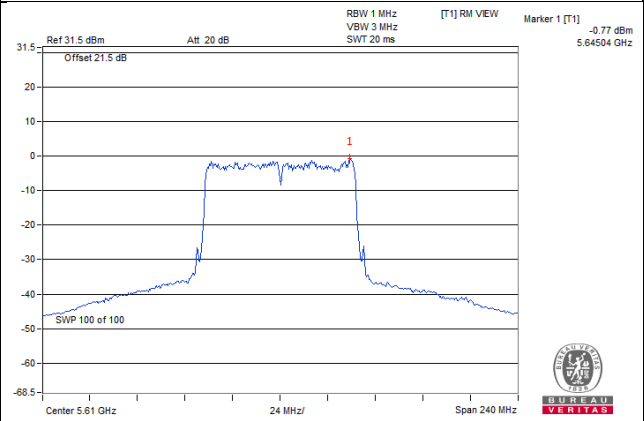

For U-NII-3:
802.11a

TX chain	Chan.	Chan. Freq. (MHz)	PSD W/O Duty Factor		10 log (N=4) dB	Duty Factor (dB)	Total PSD With Duty Factor (dBm/500kHz)	Limit (dBm/500kHz)	Pass /Fail
			(dBm/300kHz)	(dBm/500kHz)					
0	144 (U-NII-3 Band)	5720	-5.25	-3.03	6.02	0.4	3.39	30	Pass
1	144 (U-NII-3 Band)	5720	-6.19	-3.97	6.02	0.4	2.45	30	Pass
2	144 (U-NII-3 Band)	5720	-4.45	-2.23	6.02	0.4	4.19	30	Pass
3	144 (U-NII-3 Band)	5720	-5.72	-3.50	6.02	0.4	2.92	30	Pass

Note: 1. The directional gain = 3.56dBi < 6dBi, so the power density limit shall not be reduced.
 2. Refer to section 3.3 for duty cycle spectrum plot.

802.11ac (VHT20)

TX chain	Chan.	Chan. Freq. (MHz)	PSD		10 log (N=4) dB	Total PSD (dBm/500kHz)	Limit (dBm/500kHz)	Pass /Fail
			(dBm/300kHz)	(dBm/500kHz)				
0	144 (U-NII-3 Band)	5720	-4.12	-1.90	6.02	4.12	30	Pass
1	144 (U-NII-3 Band)	5720	-4.99	-2.77	6.02	3.25	30	Pass
2	144 (U-NII-3 Band)	5720	-3.45	-1.23	6.02	4.79	30	Pass
3	144 (U-NII-3 Band)	5720	-4.80	-2.58	6.02	3.44	30	Pass

Note: 1. The directional gain = 3.56dBi < 6dBi, so the power density limit shall not be reduced.

802.11ac (VHT40)

TX chain	Chan.	Chan. Freq. (MHz)	PSD W/O Duty Factor		10 log (N=4) dB	Duty Factor (dB)	Total PSD With Duty Factor (dBm/500kHz)	Limit (dBm/500kHz)	Pass /Fail
			(dBm/300kHz)	(dBm/500kHz)					
0	142 (U-NII-3 Band)	5710	-7.90	-5.68	6.02	0.14	0.48	30	Pass
1	142 (U-NII-3 Band)	5710	-7.19	-4.97	6.02	0.14	1.19	30	Pass
2	142 (U-NII-3 Band)	5710	-7.54	-5.32	6.02	0.14	0.84	30	Pass
3	142 (U-NII-3 Band)	5710	-8.37	-6.15	6.02	0.14	0.01	30	Pass

Note: 1. The directional gain = 3.56dBi < 6dBi, so the power density limit shall not be reduced.
 2. Refer to section 3.3 for duty cycle spectrum plot.

802.11ac (VHT80)

TX chain	Chan.	Chan. Freq. (MHz)	PSD W/O Duty Factor		10 log (N=4) dB	Duty Factor (dB)	Total PSD With Duty Factor (dBm/500kHz)	Limit (dBm/500kHz)	Pass /Fail
			(dBm/300kHz)	(dBm/500kHz)					
0	138 (U-NII-3 Band)	5690	-11.04	-8.82	6.02	0.23	-2.57	30	Pass
1	138 (U-NII-3 Band)	5690	-11.11	-8.89	6.02	0.23	-2.64	30	Pass
2	138 (U-NII-3 Band)	5690	-10.22	-8.00	6.02	0.23	-1.75	30	Pass
3	138 (U-NII-3 Band)	5690	-10.19	-7.97	6.02	0.23	-1.72	30	Pass

Note: 1. The directional gain = 3.56dBi < 6dBi, so the power density limit shall not be reduced.
 2. Refer to section 3.3 for duty cycle spectrum plot.

Spectrum Plot of Worst Value

802.11a_Chain 2 / 144 (U-NII-3)

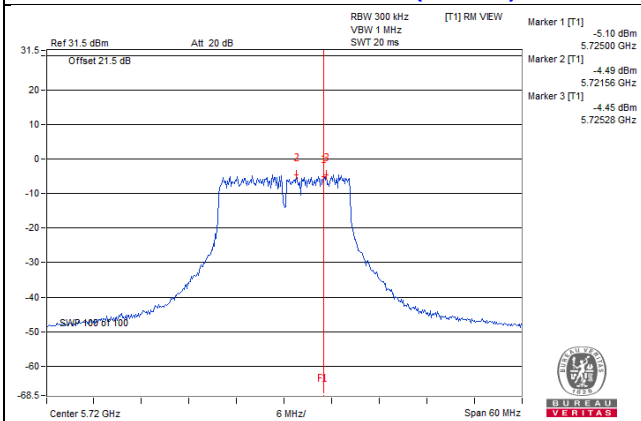

802.11ac (VHT20)_Chain 2 / 144 (U-NII-3)

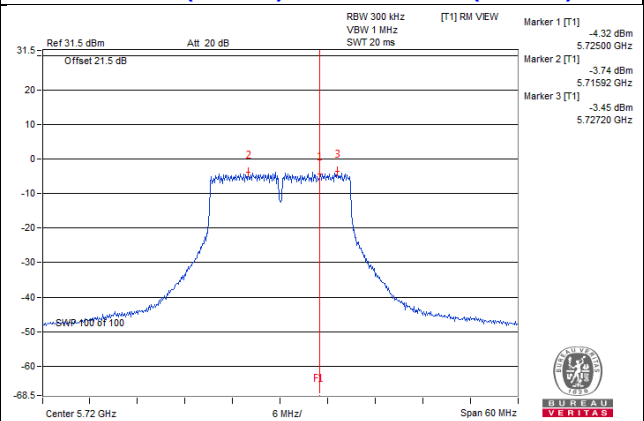

802.11ac (VHT40)_Chain 1 / 142 (U-NII-3)

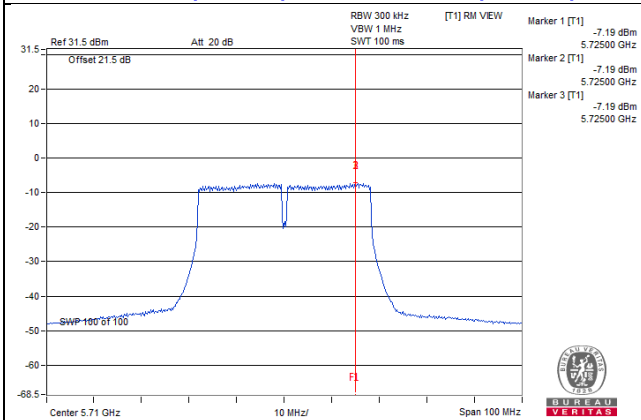

802.11ac (VHT80)_Chain 3 / 138 (U-NII-3)

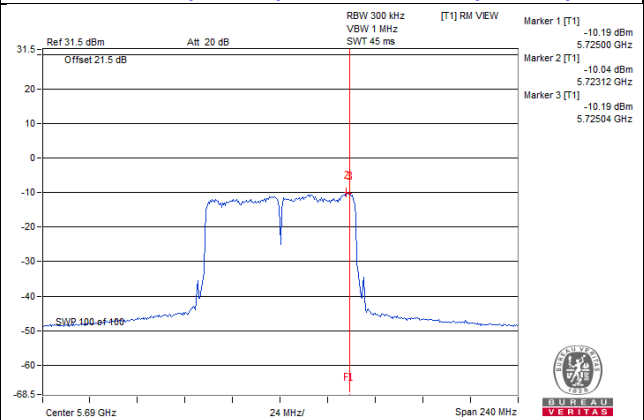

4.6 Frequency Stability Measurement

4.6.1 Limits of Frequency Stability Measurement

The frequency of the carrier signal shall be maintained within band of operation

4.6.2 Test Setup

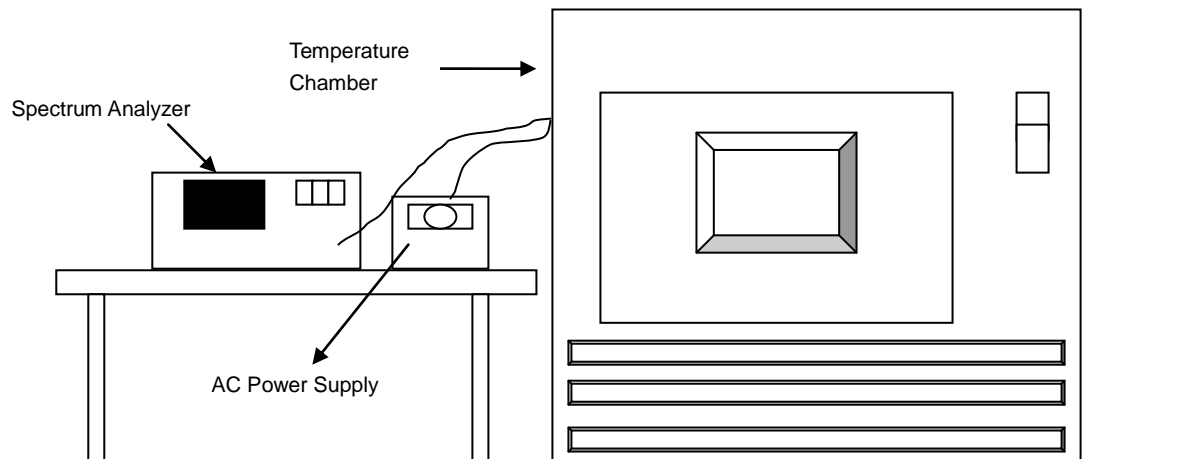

4.6.3 Test Instruments

Refer to section 4.1.2 to get information of above instrument.

4.6.4 Test Procedure

- The EUT was placed inside the environmental test chamber and powered by nominal AC voltage.
- Turn the EUT on and couple its output to a spectrum analyzer.
- Turn the EUT off and set the chamber to the highest temperature specified.
- Allow sufficient time (approximately 30 min) for the temperature of the chamber to stabilize, turn the EUT on and measure the operating frequency after 2, 5, and 10 Minutes.
- Repeat step 2 and 3 with the temperature chamber set to the lowest temperature.
- The test chamber was allowed to stabilize at +20 degree C for a minimum of 30 Minutes. The supply voltage was then adjusted on the EUT from 85% to 115% and the frequency record.

4.6.5 Deviation from Test Standard

No deviation.

4.6.6 EUT Operating Condition

Set the EUT transmit at un-modulation mode to test frequency stability.

4.6.7 Test Results

Frequency Stability Versus Temp.									
Operating Frequency: 5260 MHz									
TEMP. (°C)	Power Supply (Vac)	0 Minute		2 Minutes		5 Minutes		10 Minutes	
		Measured Frequency (MHz)	Pass/Fail	Measured Frequency (MHz)	Pass/Fail	Measured Frequency (MHz)	Pass/Fail	Measured Frequency (MHz)	Pass/Fail
50	120	5259.9764	Pass	5259.975	Pass	5259.9744	Pass	5259.9783	Pass
40	120	5259.9914	Pass	5259.9923	Pass	5259.9925	Pass	5259.9933	Pass
30	120	5260.0135	Pass	5260.0112	Pass	5260.0105	Pass	5260.0104	Pass
20	120	5260.0217	Pass	5260.0186	Pass	5260.0211	Pass	5260.0206	Pass
10	120	5260.0013	Pass	5259.998	Pass	5260.0008	Pass	5260.0016	Pass
0	120	5259.9792	Pass	5259.9822	Pass	5259.9781	Pass	5259.9804	Pass
-10	120	5259.9806	Pass	5259.9834	Pass	5259.9798	Pass	5259.9819	Pass
-20	120	5260.0133	Pass	5260.0096	Pass	5260.0122	Pass	5260.0115	Pass
-30	120	5260.0078	Pass	5260.0077	Pass	5260.0114	Pass	5260.0098	Pass

Frequency Stability Versus Voltage									
Operating Frequency: 5260 MHz									
TEMP. (°C)	Power Supply (Vac)	0 Minute		2 Minutes		5 Minutes		10 Minutes	
		Measured Frequency (MHz)	Pass/Fail	Measured Frequency (MHz)	Pass/Fail	Measured Frequency (MHz)	Pass/Fail	Measured Frequency (MHz)	Pass/Fail
20	138	5260.0227	Pass	5260.0188	Pass	5260.0201	Pass	5260.0214	Pass
	120	5260.0217	Pass	5260.0186	Pass	5260.0211	Pass	5260.0206	Pass
	102	5260.022	Pass	5260.0188	Pass	5260.0213	Pass	5260.0207	Pass

4.7 6dB Bandwidth Measurement

4.7.1 Limits of 6dB Bandwidth Measurement

The minimum of 6dB Bandwidth Measurement is 0.5MHz.

4.7.2 Test Setup

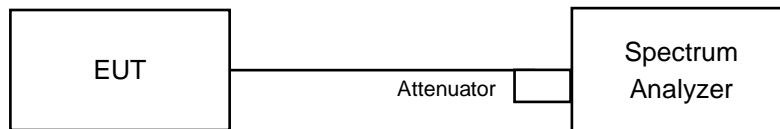

4.7.3 Test Instruments

Refer to section 4.1.2 to get information of above instrument.

4.7.4 Test Procedure

MEASUREMENT PROCEDURE REF

- Set resolution bandwidth (RBW) = 100kHz
- Set the video bandwidth (VBW) $\geq 3 \times$ RBW, Detector = Peak.
- Trace mode = max hold.
- Sweep = auto couple.
- Measure the maximum width of the emission that is constrained by the frequencies associated with the two amplitude points (upper and lower) that are attenuated by 6 dB relative to the maximum level measured in the fundamental emission

4.7.5 Deviation from Test Standard

No deviation.

4.7.6 EUT Operating Condition

The software provided by client to enable the EUT under transmission condition continuously at lowest, middle and highest channel frequencies individually.

4.7.7 Test Results

CDD Mode

802.11a

Channel	Frequency (MHz)	6dB Bandwidth (MHz)				Minimum Limit (MHz)	Pass / Fail
		Chain 0	Chain 1	Chain 2	Chain 3		
144 (U-NII-3 Band)	5720	3.18	3.17	3.18	3.20	0.5	Pass

Note: The 6dB bandwidth above 5725MHz = Marker 1 + Delta 2 - 5725MHz

802.11ac (VHT20)

Channel	Frequency (MHz)	6dB Bandwidth (MHz)				Minimum Limit (MHz)	Pass / Fail
		Chain 0	Chain 1	Chain 2	Chain 3		
144 (U-NII-3 Band)	5720	3.80	3.81	3.82	3.82	0.5	Pass

Note: The 6dB bandwidth above 5725MHz = Marker 1 + Delta 2 - 5725MHz

802.11ac (VHT40)

Channel	Frequency (MHz)	6dB Bandwidth (MHz)				Minimum Limit (MHz)	Pass / Fail
		Chain 0	Chain 1	Chain 2	Chain 3		
142 (U-NII-3 Band)	5710	3.22	3.23	3.23	3.23	0.5	Pass

Note: The 6dB bandwidth above 5725MHz = Marker 1 + Delta 2 - 5725MHz

802.11ac (VHT80)

Channel	Frequency (MHz)	6dB Bandwidth (MHz)				Minimum Limit (MHz)	Pass / Fail
		Chain 0	Chain 1	Chain 2	Chain 3		
138 (U-NII-3 Band)	5690	2.76	2.76	2.72	2.72	0.5	Pass

Note: The 6dB bandwidth above 5725MHz = Marker 1 + Delta 2 - 5725MHz

Spectrum Plot of Worst Value

802.11a_Chain 1 / CH144 (U-NII-3)

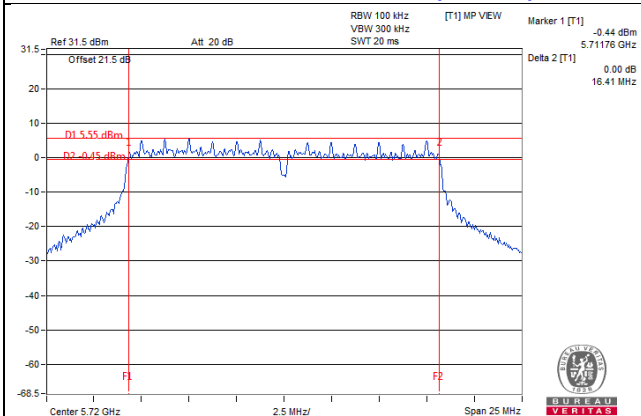

802.11ac (VHT20)_Chain 0 / CH144 (U-NII-3)

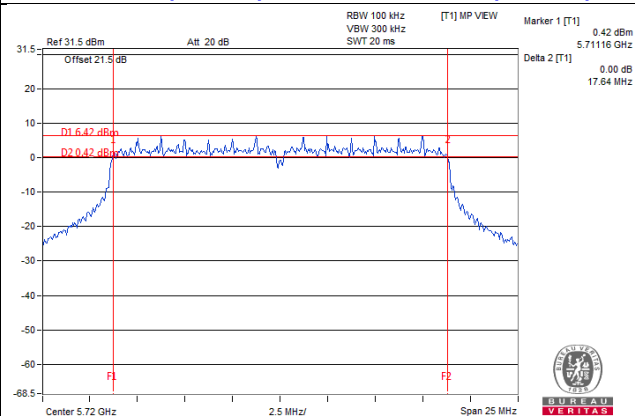

802.11ac (VHT40)_Chain 0 / CH142 (U-NII-3)

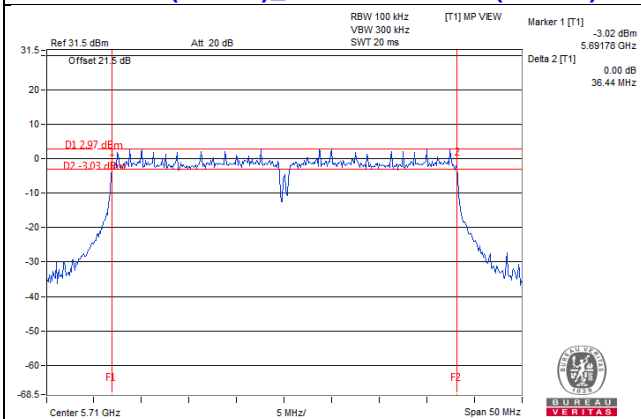

802.11ac (VHT80)_Chain 2 / CH138 (U-NII-3)

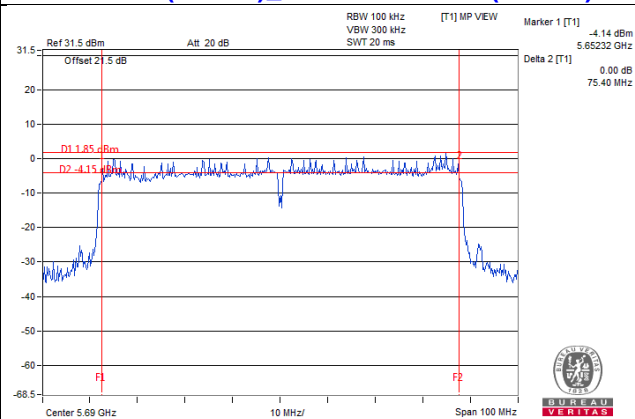

5 Pictures of Test Arrangements

Please refer to the attached file (Test Setup Photo).

Appendix – Information on the Testing Laboratories

We, Bureau Veritas Consumer Products Services (H.K.) Ltd., Taoyuan Branch, were founded in 1988 to provide our best service in EMC, Radio, Telecom and Safety consultation. Our laboratories are FCC recognized accredited test firms and accredited according to ISO/IEC 17025.

If you have any comments, please feel free to contact us at the following:

Linkou EMC/RF Lab

Tel: 886-2-26052180

Fax: 886-2-26051924

Hsin Chu EMC/RF/Telecom Lab

Tel: 886-3-6668565

Fax: 886-3-6668323

Hwa Ya EMC/RF/Safety Lab

Tel: 886-3-3183232

Fax: 886-3-3270892

Email: service.adt@tw.bureauveritas.com

Web Site: www.bureauveritas-adt.com

The address and road map of all our labs can be found in our web site also.

--- END ---