



A D T

FCC TEST REPORT (15.407)

REPORT NO.: RF130927E08D-1

MODEL NO.: FiOS-G1100

FCC ID: 2ABTEG1100

RECEIVED: Dec. 25, 2013

TESTED: Dec. 27, 2013 to May 06, 2014

ISSUED: Sep. 16, 2014

APPLICANT: Verizon Online LLC

ADDRESS: 1300 I Street NW, Room 400W,
Washington, District of Columbia, 20005
United State

ISSUED BY: Bureau Veritas Consumer Products Services
(H.K.) Ltd., Taoyuan Branch Hsin Chu Laboratory

LAB ADDRESS : No. 81-1, Lu Liao Keng, 9th Ling, Wu Lung Tsuen,
Chiung Lin Hsiang, Hsin Chu Hsien 307, Taiwan,
R.O.C.

TEST LOCATION (1): No. 81-1, Lu Liao Keng, 9th Ling, Wu Lung Tsuen,
Chiung Lin Hsiang, Hsin Chu Hsien 307, Taiwan,
R.O.C.

TEST LOCATION (2): No. 49, Ln. 206, Wende Rd., Shangshan Tsuen,
Chiung Lin Hsiang, Hsin Chu Hsien 307, Taiwan,
R.O.C.

This report should not be used by the client to claim product certification, approval, or endorsement by TAF or any government agencies.



This report is for your exclusive use. Any copying or replication of this report to or for any other person or entity, or use of our name or trademark, is permitted only with our prior written permission. This report sets forth our findings solely with respect to the test samples identified herein. The results set forth in this report are not indicative or representative of the quality or characteristics of the lot from which a test sample was taken or any similar or identical product unless specifically and expressly noted. Our report includes all of the tests requested by you and the results thereof based upon the information that you provided to us. You have 60 days from date of issuance of this report to notify us of any material error or omission caused by our negligence, provided, however, that such notice shall be in writing and shall specifically address the issue you wish to raise. A failure to raise such issue within the prescribed time shall constitute your unqualified acceptance of the completeness of this report, the tests conducted and the correctness of the report contents. Unless specific mention, the uncertainty of measurement has been explicitly taken into account to declare the compliance or non-compliance to the specification



A D T

Table of Contents

RELEASE CONTROL RECORD	4
1. CERTIFICATION	5
2. SUMMARY OF TEST RESULTS	6
2.1 MEASUREMENT UNCERTAINTY	7
3. GENERAL INFORMATION.....	8
3.1 GENERAL DESCRIPTION OF EUT	8
3.2 DESCRIPTION OF TEST MODES	12
3.2.1 TEST MODE APPLICABILITY AND TESTED CHANNEL DETAIL	14
3.3 GENERAL DESCRIPTION OF APPLIED STANDARDS	18
3.4 DUTY CYCLE OF TEST SIGNAL.....	19
3.5 DESCRIPTION OF SUPPORT UNITS	23
3.6 CONFIGURATION OF SYSTEM UNDER TEST	24
4. TEST TYPES AND RESULTS	26
4.1 CONDUCTED EMISSION MEASUREMENT	26
4.1.1 LIMITS OF CONDUCTED EMISSION MEASUREMENT	26
4.1.2 TEST INSTRUMENTS	26
4.1.3 TEST PROCEDURES	27
4.1.4 DEVIATION FROM TEST STANDARD	28
4.1.5 TEST SETUP	28
4.1.6 EUT OPERATING CONDITIONS	28
4.1.7 TEST RESULTS (MODE 1)	29
4.1.8 TEST RESULTS (MODE 2)	31
4.2 RADIATED EMISSION AND BANDEDGE MEASUREMENT	33
4.2.1 LIMITS OF RADIATED EMISSION AND BANDEDGE MEASUREMENT	33
4.2.2 LIMITS OF UNWANTED EMISSION OUT OF THE RESTRICTED BANDS	33
4.2.3 TEST INSTRUMENTS	34
4.2.4 TEST PROCEDURES	36
4.2.5 DEVIATION FROM TEST STANDARD	36
4.2.6 TEST SETUP	37
4.2.7 EUT OPERATING CONDITION	37
4.2.8 TEST RESULTS (MODE 1)	38
4.2.9 TEST RESULTS (MODE 2)	72
4.2.10 TEST RESULTS (MODE 3)	107
4.3 TRANSMIT POWER MEASUREMENT	115
4.3.1 LIMITS OF TRANSMIT POWER MEASUREMENT	115
4.3.2 TEST INSTRUMENTS	115
4.3.3 TEST PROCEDURE	116
4.3.4 DEVIATION FROM TEST STANDARD	117
4.3.5 TEST SETUP	118



A D T

4.3.6	EUT OPERATING CONDITIONS	118
4.3.7	TEST RESULTS (MODE 1).....	119
4.3.8	TEST RESULTS (MODE 2).....	181
4.3.9	TEST RESULTS (MODE 3).....	215
4.4	PEAK POWER SPECTRAL DENSITY MEASUREMENT	219
4.4.1	LIMITS OF PEAK POWER SPECTRAL DENSITY MEASUREMENT.....	219
4.4.2	TEST INSTRUMENTS	219
4.4.3	TEST PROCEDURES	219
4.4.4	DEVIATION FROM TEST STANDARD	219
4.4.5	TEST SETUP	220
4.4.6	EUT OPERATING CONDITIONS	220
4.4.7	TEST RESULTS (MODE 1).....	221
4.4.8	TEST RESULTS (MODE 2).....	233
4.4.9	TEST RESULTS (MODE 3).....	240
4.5	PEAK POWER EXCURSION MEASUREMENT	241
4.5.1	LIMITS OF PEAK POWER EXCURSION MEASUREMENT.....	241
4.5.2	TEST INSTRUMENTS	241
4.5.3	TEST PROCEDURE	241
4.5.4	DEVIATION FROM TEST STANDARD	241
4.5.5	TEST SETUP	241
4.5.6	EUT OPERATING CONDITIONS	242
4.5.7	TEST RESULTS (MODE 1).....	243
4.5.8	TEST RESULTS (MODE 3).....	245
4.6	FREQUENCY STABILITY	246
4.6.1	LIMITS OF FREQUENCY STABILITY MEASUREMENT	246
4.6.2	TEST INSTRUMENTS	246
4.6.3	TEST PROCEDURE	246
4.6.4	DEVIATION FROM TEST STANDARD	247
4.6.5	TEST SETUP	247
4.6.6	EUT OPERATING CONDITION	247
4.6.7	TEST RESULTS	248
5.	PHOTOGRAPHS OF THE TEST CONFIGURATION.....	249
6.	INFORMATION ON THE TESTING LABORATORIES	250
7.	APPENDIX A - MODIFICATIONS RECORDERS FOR ENGINEERING CHANGES TO THE EUT BY THE LAB.....	251



A D T

RELEASE CONTROL RECORD

ISSUE NO.	REASON FOR CHANGE	DATE ISSUED
RF130927E08D-1	Original release	Sep. 16, 2014



A D T

1. CERTIFICATION

PRODUCT: FiOS Quantum Gateway
BRAND NAME: Verizon
MODEL NO.: FiOS-G1100
TEST SAMPLE: ENGINEERING SAMPLE
APPLICANT: Verizon Online LLC
TESTED: Dec. 27, 2013 to May 06, 2014
STANDARDS: FCC Part 15, Subpart E (Section 15.407)
ANSI C63.10-2009

The above equipment (Model: FiOS-G1100) has been tested by **Bureau Veritas Consumer Products Services (H.K.) Ltd., Taoyuan Branch**, and found compliance with the requirement of the above standards. The test record, data evaluation & Equipment Under Test (EUT) configurations represented herein are true and accurate accounts of the measurements of the sample's EMC characteristics under the conditions specified in this report.

PREPARED BY :  , **DATE:** Sep. 16, 2014
(Lori Chung, Specialist)

APPROVED BY :  , **DATE:** Sep. 16, 2014
(May Chen, Manager)



A D T

2. SUMMARY OF TEST RESULTS

The EUT has been tested according to the following specifications:

For 5GHz, 5260~5320MHz, 5500~5580MHz & 5660~5700MHz

APPLIED STANDARD: FCC PART 15, SUBPART E (SECTION 15.407)			
STANDARD SECTION	TEST TYPE	RESULT	REMARK
15.407(b)(6)	AC Power Conducted Emission	PASS	Meet the requirement of limit. Minimum passing margin is -14.46dB at 0.49800MHz
15.407(b/1/2/3) (b)(5)	Spurious Emissions	PASS	Meet the requirement of limit. Minimum passing margin is -0.2dB at 5378.00MHz, 5394.00MHz, 5400.00MHz, 5420.00MHz, 5425.00MHz, 5470.00MHz, 5733.00MHz, 5780.00MHz, 5833.00MHz, 5859.00MHz, 5865.00MHz, 5881.00MHz & 5882.00MHz
15.407(a/1/2/3)	Transmit Power	PASS	Meet the requirement of limit.
15.407(a)(6)	Peak Power Excursion	PASS	Meet the requirement of limit.
15.407(a/1/2/3)	Peak Power Spectral Density	PASS	Meet the requirement of limit.
15.407(g)	Frequency Stability	PASS	Meet the requirement of limit.
15.203	Antenna Requirement	PASS	No antenna connector is used.

NOTE:

1. This report is prepared for FCC class II change. (Add DFS band: 5250~5350MHz & 5470~5725MHz).
2. The DFS report was recorded in another test report.



A D T

2.1 MEASUREMENT UNCERTAINTY

Where relevant, the following measurement uncertainty levels have been estimated for tests performed on the EUT as specified in CISPR 16-4-2:

This uncertainty represents an expanded uncertainty expressed at approximately the 95% confidence level using a coverage factor of $k=2$.

Measurement	Value
Conducted emissions	2.86dB
Radiated emissions (30MHz-1GHz)	5.37 dB
Radiated emissions (1GHz -6GHz)	3.72 dB
Radiated emissions (6GHz -18GHz)	4.00 dB
Radiated emissions (18GHz -40GHz)	4.11 dB



A D T

3. GENERAL INFORMATION

3.1 GENERAL DESCRIPTION OF EUT (FOR DFS BAND)

PRODUCT	FiOS Quantum Gateway
MODEL NO.	FiOS-G1100
POWER SUPPLY	DC 12V from power adapter
MODULATION TYPE	64QAM, 16QAM, QPSK, BPSK for OFDM 256QAM for OFDM in 11ac mode only.
MODULATION TECHNOLOGY	OFDM
TRANSFER RATE	802.11a: up to 54Mbps 802.11n: up to 450Mbps 802.11ac: up to 1300Mbps
OPERATING FREQUENCY	5.26 ~ 5.32GHz, 5.50 ~ 5.58GHz & 5.66GHz ~ 5.72GHz
NUMBER OF CHANNEL	13 for 802.11a, 802.11n (HT20), 802.11ac (VHT20) 6 for 802.11n (HT40), 802.11ac (VHT40) 3 for 802.11ac (VHT80)
MAXIMUM OUTPUT POWER	Please see NOTE
ANTENNA TYPE	Please see NOTE
DATA CABLE	NA
I/O PORTS	Refer to user's manual
ASSOCIATED DEVICES	Adapter x1 Zigbee module (option) x1

NOTE:

1. This report is prepared for FCC class II permissive change. The difference compared with the original report design is as the following information:
 - ◆ Add DFS band <5250~5350MHz & 5470~5725MHz>



- There are Z-Wave technology and WLAN (2.4GHz & 5GHz) technology used for the EUT.
- The EUT inside has one Zigbee technology module (option).

Zigbee module (test only)		
Product Name	Brand	FCC ID
Zigbee Wireless Module	Verizon	Z3M-ZBMOD1

- The emission of the simultaneous operation (Z-Wave, Zigbee & WLAN) has been evaluated and no non-compliance was found.
- The DUT will not transmit simultaneously in U_NII 2C band and DTS frequency band in the same time.
- The maximum output power table as below table:

MAXIMUM OUTPUT POWER (mW)							
15.407							
Test Mode	802.11a	802.11ac (VHT20)		802.11ac (VHT40)		802.11ac (VHT80)	
1Tx	14.028						
2Tx		CDD, SDM, Beamforming	STBC	CDD, SDM, Beamforming	STBC	CDD, SDM, Beamforming	STBC
		55.855	63.341	80.528	93.307	96.912	96.912
3Tx		CDD, SDM, Beamforming	STBC	CDD, SDM, Beamforming	STBC	CDD, SDM, Beamforming	STBC
		67.047	51.213	52.930	82.107	52.37	83.069

- The antennas provided to the EUT, please refer to the following table:

WLAN Antenna Spec.				
Transmitter Circuit	Gain (dBi) (Include cable loss)	Antenna Type	Connector Type	Frequency range (GHz to GHz)
Chain (0)	3.97	Metal	NA	2.4~2.4835
	3.56			5.15~5.25
	3.86			5.25~5.35
	4.05			5.47~5.725
	4.05			5.725~5.85
Chain (1)	4.1	Metal	NA	2.4~2.4835
	5.3			5.15~5.25
	5.75			5.25~5.35
	5.75			5.47~5.725
	5.71			5.725~5.85
Chain (2)	3.36	Metal	NA	2.4~2.4835
	4.6			5.15~5.25
	4.35			5.25~5.35
	4.35			5.47~5.725
	4.21			5.725~5.85



Z-Wave Antenna Spec.			
Gain (dBi) (Include cable loss)	Antenna Type	Connector Type	Frequency range (MHz to MHz)
1.73	Metal	NA	902~928
Note: 1. For 1Tx mode will fix transmission on Chain (0). 2. For 2Tx mode will fix transmission on Chain (0) and Chain (1)			

8. The EUT must be supplied with a power adapter and following two different model names could be chosen:

No.	Brand	Model No.	Spec.
1	Ktec	KSAS0361200300HU	AC Input : 100-240V, 1.0A, 50/60Hz DC Output : 12V, 3.0A DC output cable(unshielded ,1.8m)
2	LEI	MU36-8120300-A1	AC Input : 100-240V, 1.0A, 50/60Hz DC Output : 12V, 3.0A DC output cable(unshielded ,1.8m)

For the original test report: the above adapters, the worst radiated emission was found in **Adapter 1**. Therefore only the test data of the modes were recorded in this report.

9. The specifications of EUT listed as below:

MODULATION MODE	TX/RX FUNCTION
802.11b	1TX/3RX
	2TX/3RX(CDD Mode)
	3TX/3RX(CDD Mode)
802.11g	1TX/3RX
802.11n (HT20) & 802.11n (HT40)	1TX/3RX
	2TX/3RX (SDM Mode)
	3TX/3RX (CDD Mode)
	3TX/3RX (STBC Mode)
	3TX/3RX (SDM Mode)
	2TX/3RX (Beamforming Mode, only 5GHz band)
	3TX/3RX (Beamforming Mode, only 5GHz band)
802.11a	1TX/3RX
802.11ac (VHT20) & 802.11ac (VHT40) & 802.11ac (VHT80)	2TX/3RX (Beamforming Mode)
	2TX/3RX (CDD Mode)
	2TX/3RX (STBC Mode)
	2TX/3RX (SDM Mode)
	3TX/3RX (Beamforming Mode)
	3TX/3RX (CDD Mode)
	3TX/3RX (STBC Mode)
	3TX/3RX (SDM Mode)

Note: The modulation and bandwidth are similar for 802.11n mode for 20MHz (40MHz) and 802.11ac mode for 20MHz (40MHz), therefore investigated worst case to representative mode in test report. (Final test mode refer section 3.2.1)



A D T

10. When the EUT operating in 802.11n, the software operation, which is defined by manufacturer, MCS (Modulation and Coding Schemes) from 0 to 23.
11. When the EUT operating in 802.11ac, the software operation, which is defined by manufacturer, MCS (Modulation and Coding Schemes) from 0 to 9.
12. The above EUT information was declared by the manufacturer and for more detailed features description, please refer to the manufacturer's specifications or User's Manual.



A D T

3.2 DESCRIPTION OF TEST MODES

Operated in 5260 ~ 5320MHz band:

4 channels are provided for 802.11a, 802.11n (HT20), 802.11ac (VHT20):

CHANNEL	FREQUENCY	CHANNEL	FREQUENCY
52	5260 MHz	60	5300 MHz
56	5280 MHz	64	5320 MHz

2 channels are provided for 802.11n (HT40), 802.11ac (VHT40):

CHANNEL	FREQUENCY
54	5270 MHz
62	5310 MHz

1 channel is provided for 802.11ac (VHT80):

CHANNEL	FREQUENCY
58	5290 MHz



Operated in 5470MHz ~ 5600MHz & 5650MHz ~ 5725MHz bands:

9 channels are provided for 802.11a, 802.11n (HT20), 802.11ac (VHT20):

CHANNEL	FREQUENCY	CHANNEL	FREQUENCY
100	5500 MHz	132	5660 MHz
104	5520 MHz	136	5680 MHz
108	5540 MHz	140	5700 MHz
112	5560 MHz	144	5720 MHz
116	5580 MHz		

4 channels are provided for 802.11n (HT40), 802.11ac (VHT40):

CHANNEL	FREQUENCY
102	5510 MHz
110	5550 MHz
134	5670 MHz
142	5710 MHz

2 channel is provided for 802.11ac (VHT80):

CHANNEL	FREQUENCY
106	5530 MHz
138	5690 MHz



3.2.1 TEST MODE APPLICABILITY AND TESTED CHANNEL DETAIL

EUT CONFIGURE MODE	APPLICABLE TO				DESCRIPTION
	PLC	RE < 1G	RE ≥ 1G	APCM	
1	√	√	√	√	3TX configuration (with Adapter 1)
2	√	-	-	-	3TX configuration (with Adapter 2)
	-	√	√	√	2TX configuration (with Adapter 1)
3	-	-	√	√	1TX configuration (with Adapter 1)

Where **PLC**: Power Line Conducted Emission **RE < 1G**: Radiated Emission below 1GHz
RE ≥ 1G: Radiated Emission above 1GHz **APCM**: Antenna Port Conducted Measurement

Notes:

1. The Peak Power Excursion test item is test 3TX configuration mode and 2TX configuration mode and Frequency Stability is only test **3Tx configuration mode**.
2. For the original test report: for 5GHz: radiated emissions above 1GHz test, the EUT's Beamforming, SDM and CDD mode had been pre-tested. The worst case was found when **CDD mode**. Therefore only the test data was recorded in this report.

POWER LINE CONDUCTED EMISSION TEST:

- Pre-Scan has been conducted to determine the worst-case mode from all possible combinations between available modulations, data rates and antenna ports (if EUT with antenna diversity architecture).
- Following channel(s) was (were) selected for the final test as listed below.

3TX CONFIGURATION					
CDD_MODE	AVAILABLE CHANNEL	TESTED CHANNEL	MODULATION TECHNOLOGY	MODULATION TYPE	DATA RATE (Mbps)
802.11ac (VHT20)	52 to 144	144	OFDM	BPSK	6.5

RADIATED EMISSION TEST (BELOW 1 GHz):

- Pre-Scan has been conducted to determine the worst-case mode from all possible combinations between available modulations, data rates and antenna ports (if EUT with antenna diversity architecture).
- Following channel(s) was (were) selected for the final test as listed below.

3TX CONFIGURATION					
CDD_MODE	AVAILABLE CHANNEL	TESTED CHANNEL	MODULATION TECHNOLOGY	MODULATION TYPE	DATA RATE (Mbps)
802.11ac (VHT20)	52 to 144	144	OFDM	BPSK	6.5

RADIATED EMISSION TEST (ABOVE 1 GHz):

- Pre-Scan has been conducted to determine the worst-case mode from all possible combinations between available modulations, data rates and antenna ports (if EUT with antenna diversity architecture).
- Following channel(s) was (were) selected for the final test as listed below.

3TX CONFIGURATION					
CDD & STBC_MODE	AVAILABLE CHANNEL	TESTED CHANNEL	MODULATION TECHNOLOGY	MODULATION TYPE	DATA RATE (Mbps)
802.11ac (VHT20)	52 to 144	52, 60, 64, 100, 116, 132, 140, 144	OFDM	BPSK	6.5
802.11ac (VHT40)	54 to 142	54, 62, 102, 110, 134, 142	OFDM	BPSK	13.5
802.11ac (VHT80)	58 to 138	58, 106, 138	OFDM	BPSK	29.3
2TX CONFIGURATION					
CDD & STBC_MODE	AVAILABLE CHANNEL	TESTED CHANNEL	MODULATION TECHNOLOGY	MODULATION TYPE	DATA RATE (Mbps)
802.11ac (VHT20)	52 to 144	52, 60, 64, 100, 116, 132, 140, 144	OFDM	BPSK	6.5
802.11ac (VHT40)	54 to 142	54, 62, 102, 110, 134, 142	OFDM	BPSK	13.5
802.11ac (VHT80)	58 to 138	58, 106, 138	OFDM	BPSK	29.3
1TX CONFIGURATION					
MODE	AVAILABLE CHANNEL	TESTED CHANNEL	MODULATION TECHNOLOGY	MODULATION TYPE	DATA RATE (Mbps)
802.11a	52 to 144	52, 60, 64, 100, 116, 132, 140, 144	OFDM	BPSK	6

ANTENNA PORT CONDUCTED MEASUREMENT:

- Pre-Scan has been conducted to determine the worst-case mode from all possible combinations between available modulations, data rates and antenna ports (if EUT with antenna diversity architecture).
- Following channel(s) was (were) selected for the final test as listed below.

3TX CONFIGURATION						
CDD & STBC_MODE	AVAILABLE CHANNEL	TESTED CHANNEL	MODULATION TECHNOLOGY	MODULATION TYPE	DATA RATE (Mbps)	
802.11ac (VHT20)	52 to 144	52, 60, 64, 100, 116, 132, 140, 144	OFDM	BPSK	6.5	
802.11ac (VHT40)	54 to 142	54, 62, 102, 110, 134, 142	OFDM	BPSK	13.5	
802.11ac (VHT80)	58 to 138	58, 106, 138	OFDM	BPSK	29.3	
SDM_MODE	AVAILABLE CHANNEL	TESTED CHANNEL	MODULATION TECHNOLOGY	MODULATION TYPE	DATA RATE (Mbps)	
802.11ac (VHT20)	52 to 144	52, 60, 64, 100, 116, 132, 140, 144	OFDM	BPSK	19.5	
802.11ac (VHT40)	54 to 142	54, 62, 102, 110, 134, 142	OFDM	BPSK	40.5	
802.11ac (VHT80)	58 to 138	58, 106, 138	OFDM	BPSK	87.8	
Beamforming_MODE	AVAILABLE CHANNEL	TESTED CHANNEL	MODULATION TECHNOLOGY	MODULATION TYPE	DATA RATE (Mbps)	NSS
802.11ac (VHT20)	52 to 144	52, 60, 64, 100, 116, 132, 140, 144	OFDM	BPSK	6.5	1
					13	2
					19.5	3
802.11ac (VHT40)	54 to 142	54, 62, 102, 110, 134, 142	OFDM	BPSK	13.5	1
					27	2
					40.5	3
802.11ac (VHT80)	58 to 138	58, 106, 138	OFDM	BPSK	29.3	1
					58.5	2
					87.8	3



2TX CONFIGURATION						
CDD & STBC_MODE	AVAILABLE CHANNEL	TESTED CHANNEL	MODULATION TECHNOLOGY	MODULATION TYPE	DATA RATE (Mbps)	
802.11ac (VHT20)	52 to 144	52, 60, 64, 100, 116, 132, 140, 144	OFDM	BPSK	6.5	
802.11ac (VHT40)	54 to 142	54, 62, 102, 110, 134, 142	OFDM	BPSK	13.5	
802.11ac (VHT80)	58 to 138	58, 106, 138	OFDM	BPSK	29.3	
SDM_MODE	AVAILABLE CHANNEL	TESTED CHANNEL	MODULATION TECHNOLOGY	MODULATION TYPE	DATA RATE (Mbps)	
802.11ac (VHT20)	52 to 144	52, 60, 64, 100, 116, 132, 140, 144	OFDM	BPSK	13	
802.11ac (VHT40)	54 to 142	54, 62, 102, 110, 134, 142	OFDM	BPSK	27	
802.11ac (VHT80)	58 to 138	58, 106, 138	OFDM	BPSK	58.5	
Beamforming_MODE	AVAILABLE CHANNEL	TESTED CHANNEL	MODULATION TECHNOLOGY	MODULATION TYPE	DATA RATE (Mbps)	NSS
802.11ac (VHT20)	52 to 144	52, 60, 64, 100, 116, 132, 140, 144	OFDM	BPSK	6.5	1
					13	2
802.11ac (VHT40)	54 to 142	54, 62, 102, 110, 134, 142	OFDM	BPSK	13.5	1
					27	2
802.11ac (VHT80)	58 to 138	58, 106, 138	OFDM	BPSK	29.3	1
					58.5	2
1TX CONFIGURATION						
MODE	AVAILABLE CHANNEL	TESTED CHANNEL	MODULATION TECHNOLOGY	MODULATION TYPE	DATA RATE (Mbps)	
802.11a	52 to 144	52, 60, 64, 100, 116, 132, 140, 144	OFDM	BPSK	6	

TEST CONDITION:

APPLICABLE TO	ENVIRONMENTAL CONDITIONS	INPUT POWER	TESTED BY
PLC	23deg. C, 62%RH	120Vac, 60Hz	Barry Lee
RE<1G	24deg. C, 70%RH	120Vac, 60Hz	Gary Cheng
RE≥1G	25deg. C, 72%RH	120Vac, 60Hz	Robert Cheng
APCM	25deg. C, 60%RH	120Vac, 60Hz	Chilin Lee

3.3 GENERAL DESCRIPTION OF APPLIED STANDARDS

The EUT is a RF product. According to the specifications of the manufacturer, it must comply with the requirements of the following standards:

FCC Part 15, Subpart E (15.407)

789033 D01 General UNII Test Procedures Old Rules v01r04

662911 D01 Multiple Transmitter Output v02r01

ANSI C63.10-2009

All test items have been performed and recorded as per the above standards.

Note: The EUT has been verified to comply with the requirements of FCC Part 15, Subpart B, Class B (DoC). The test report has been issued separately.

3.4 DUTY CYCLE OF TEST SIGNAL

If duty cycle of test signal is $\geq 98\%$, duty factor is not required.

If duty cycle of test signal is $< 98\%$, duty factor shall be considered.

802.11a

BPSK: Duty cycle = 2.06 ms/2.08 ms = 0.99

QPSK: Duty cycle = 1.04 ms/1.05875 ms = 0.982

16QAM: Duty cycle = 0.533 ms/0.5495 ms = 0.97, Duty factor = $10 * \log(1/0.97) = 0.13$

64QAM: Duty cycle = 0.278 ms/0.29325 ms = 0.948, Duty factor = $10 * \log(1/0.948) = 0.23$

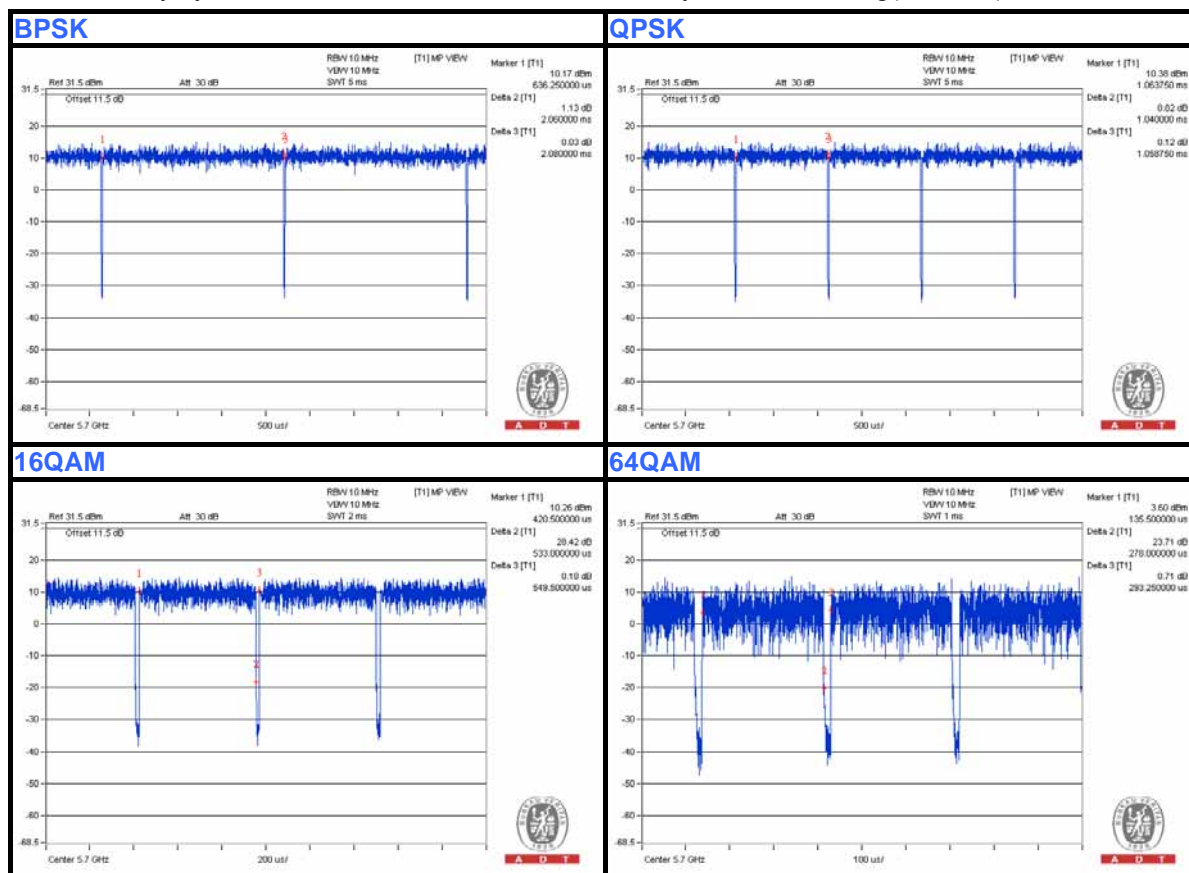



A D T

802.11ac (VHT20)

BPSK: Duty cycle = 1.925 ms/1.94625 ms = 0.989

QPSK: Duty cycle = 0.9775 ms/1.00375 ms = 0.974, Duty factor = $10 * \log(1/0.974) = 0.12$

16QAM: Duty cycle = 0.513 ms/0.53 ms = 0.968, Duty factor = $10 * \log(1/0.968) = 0.14$

64QAM: Duty cycle = 0.27825 ms/0.29325 ms = 0.949, Duty factor = $10 * \log(1/0.949) = 0.23$

256QAM: Duty cycle = 0.202 ms/0.2175 ms = 0.929, Duty factor = $10 * \log(1/0.929) = 0.32$

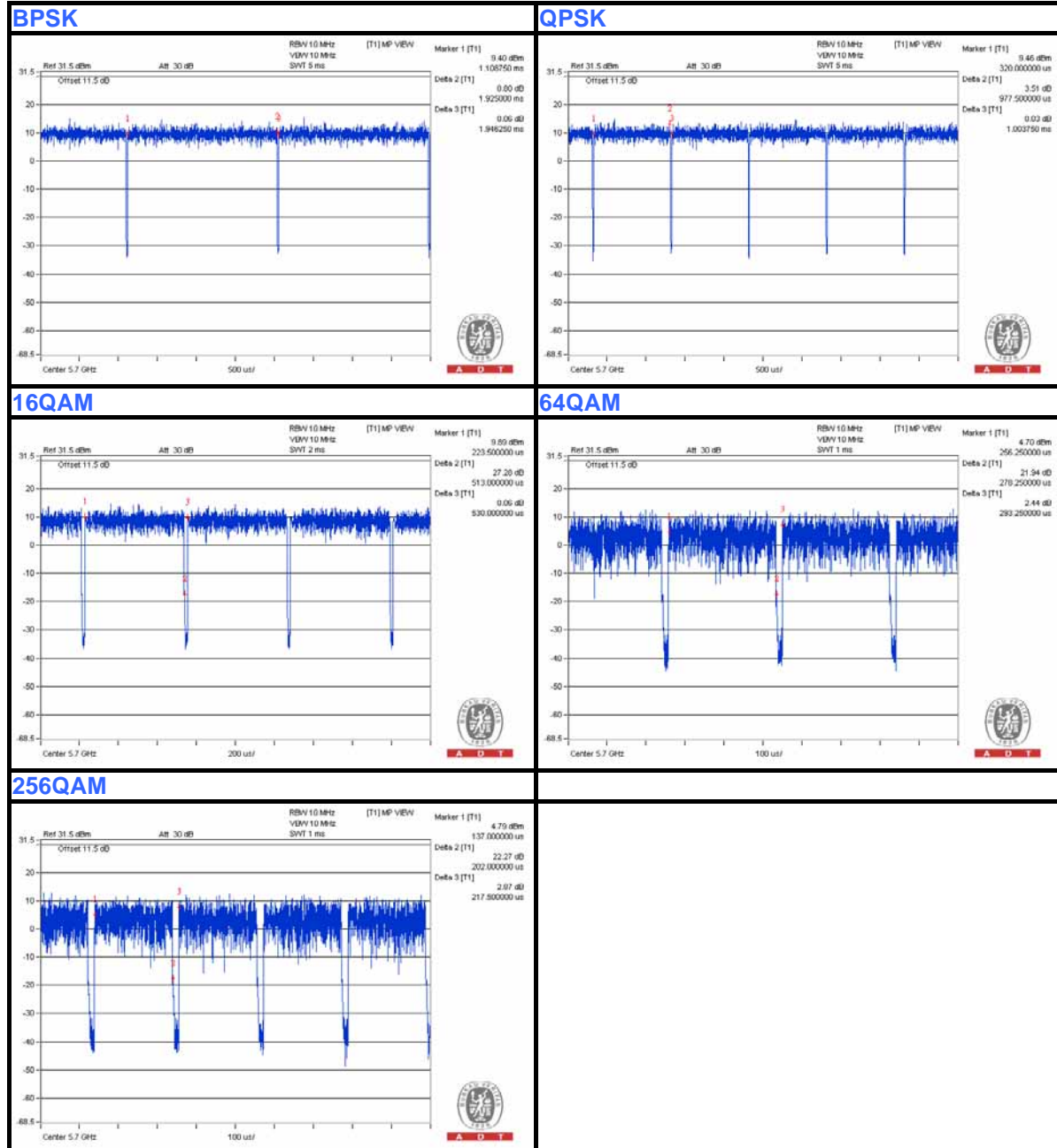



A D T

802.11ac (VHT40)

BPSK: Duty cycle = 0.954 ms/0.9695 ms = 0.984

QPSK: Duty cycle = 0.498 ms/0.5135 ms = 0.97, Duty factor = $10 * \log(1/0.97) = 0.13$

16QAM: Duty cycle = 0.2705 ms/0.2855 ms = 0.947, Duty factor = $10 * \log(1/0.947) = 0.23$

64QAM: Duty cycle = 0.15587 ms/0.173 ms = 0.901, Duty factor = $10 * \log(1/0.901) = 0.45$

256QAM: Duty cycle = 0.1155 ms/0.1335 ms = 0.865, Duty factor = $10 * \log(1/0.865) = 0.63$

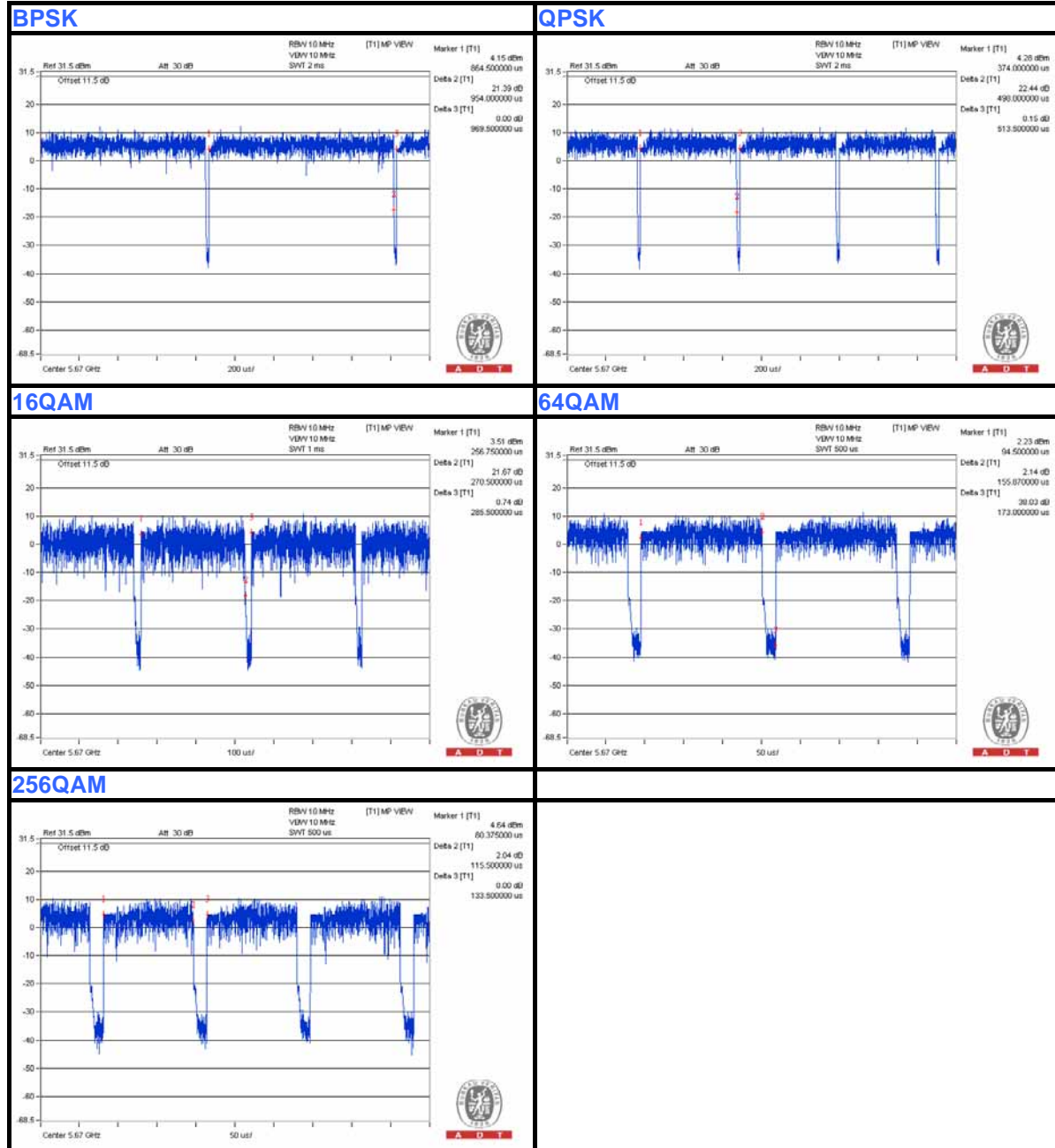



A D T

802.11ac (VHT80)

BPSK: Duty cycle = 0.461 ms/0.477 ms = 0.966, Duty factor = $10 * \log(1/0.966) = 0.15$

QPSK: Duty cycle = 0.25425 ms/0.2695 ms = 0.943, Duty factor = $10 * \log(1/0.943) = 0.25$

16QAM: Duty cycle = 0.15062 ms/0.16525 ms = 0.911, Duty factor = $10 * \log(1/0.911) = 0.4$

64QAM: Duty cycle = 0.09862 ms/0.11312 ms = 0.872, Duty factor = $10 * \log(1/0.872) = 0.6$

256QAM: Duty cycle = 0.07862 ms/0.09337 ms = 0.842, Duty factor = $10 * \log(1/0.842) = 0.75$

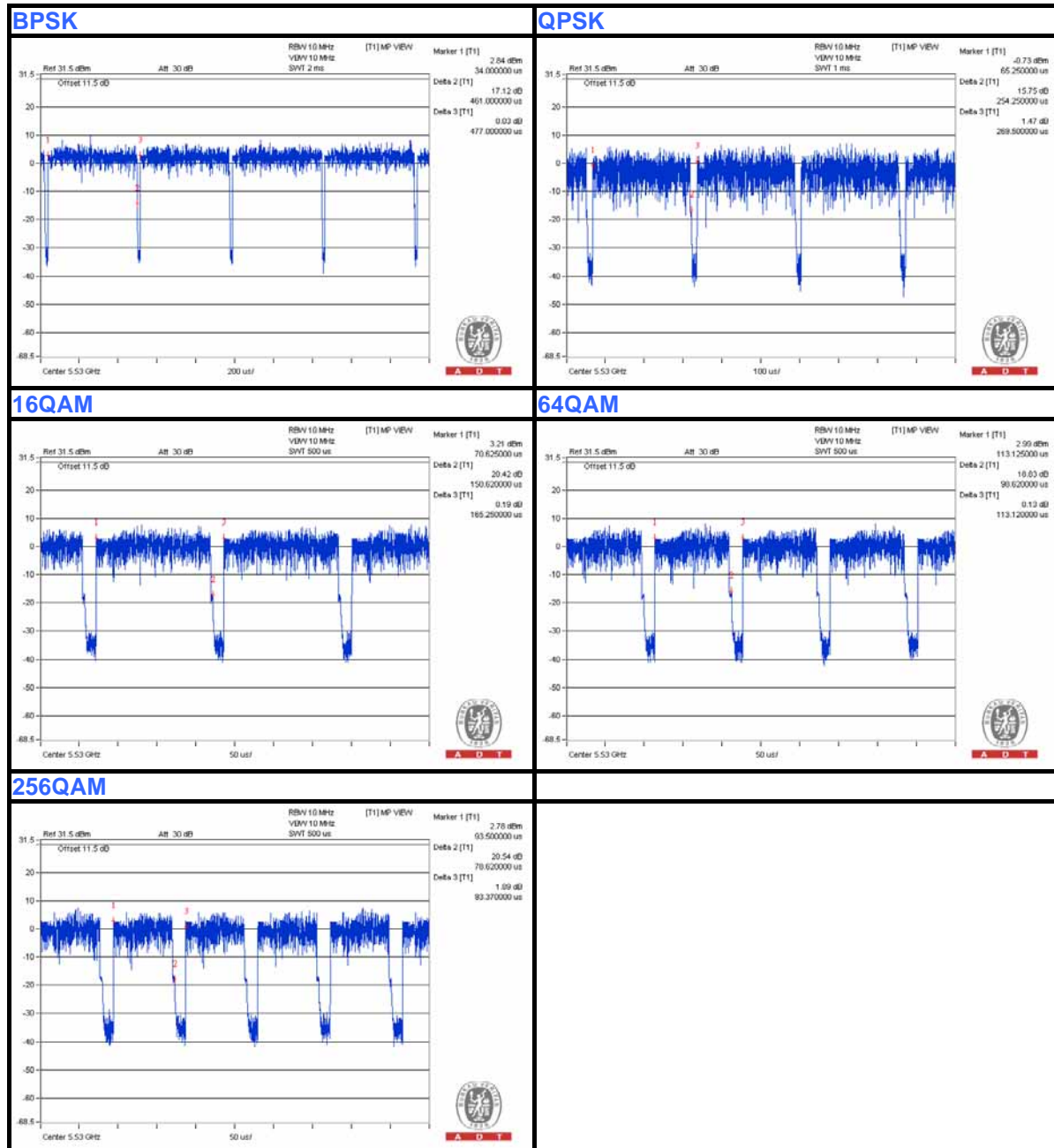



3.5 DESCRIPTION OF SUPPORT UNITS

The EUT has been tested as an independent unit together with other necessary accessories or support units. The following support units or accessories were used to form a representative test configuration during the tests.

NO.	PRODUCT	BRAND	MODEL NO.	SERIAL NO.	FCC ID
1	NOTEBOOK COMPUTER	DELL	PP32LA	FSLB32S	FCC DoC
2	NOTEBOOK COMPUTER	DELL	PP32LA	HSLB32S	FCC DoC
3	HUB	Linksys	SD028	NA	NA
4	USB FLASH DISK (for other test items)	SanDisk	SDCZ33	NA	FCC DoC
	iPod shuffle (for conducted test)	Apple	MC749TA/A	CC4DMFJUDFDM	NA
5	USB FLASH DISK (for other test items)	SanDisk	SDCZ33	NA	FCC DoC
	iPod shuffle (for conducted test)	Apple	MC749TA/A	CC4DN25WDFDM	NA
6	SPLITTER	DIRECTV	SWS-2-WNC	NA	NA
7	BROADBAND HOME ROUTER	NA	JG101	NA	NA
8	BROADBAND HOME ROUTER	NA	JG101	NA	NA

NO.	SIGNAL CABLE DESCRIPTION OF THE ABOVE SUPPORT UNITS
1	UTP Cable, 10m
2	UTP Cable, 10m
3	UTP Cable, 10m
4	NA (for other test items)
	USB Cable, 0.1m (for Conducted test)
5	NA (for other test items)
	USB Cable, 0.1m (for Conducted test)
6	Coaxial Cable, 10m
7	Coaxial Cable, 3m
8	Coaxial Cable, 3m

NOTE: All power cords of the above support units are non shielded (1.8m).

3.6 CONFIGURATION OF SYSTEM UNDER TEST

For Conducted Emission Test:

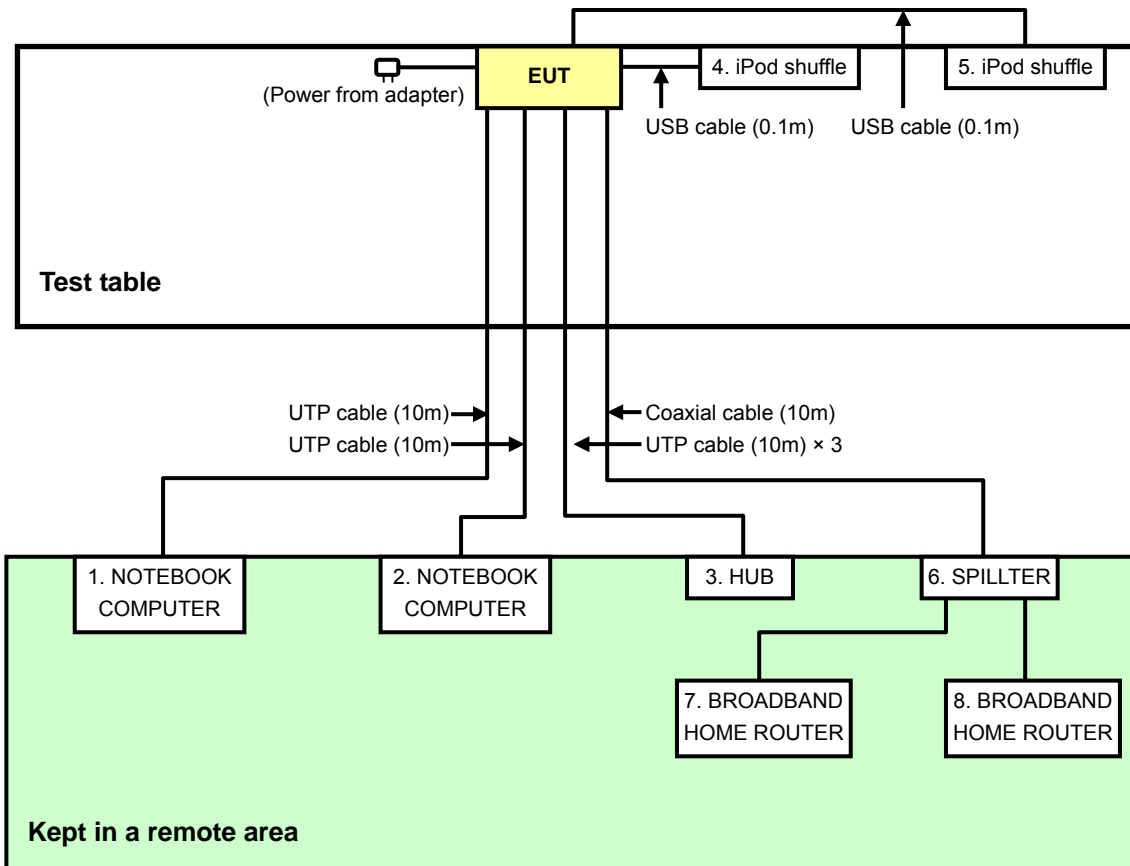

For Other test items:

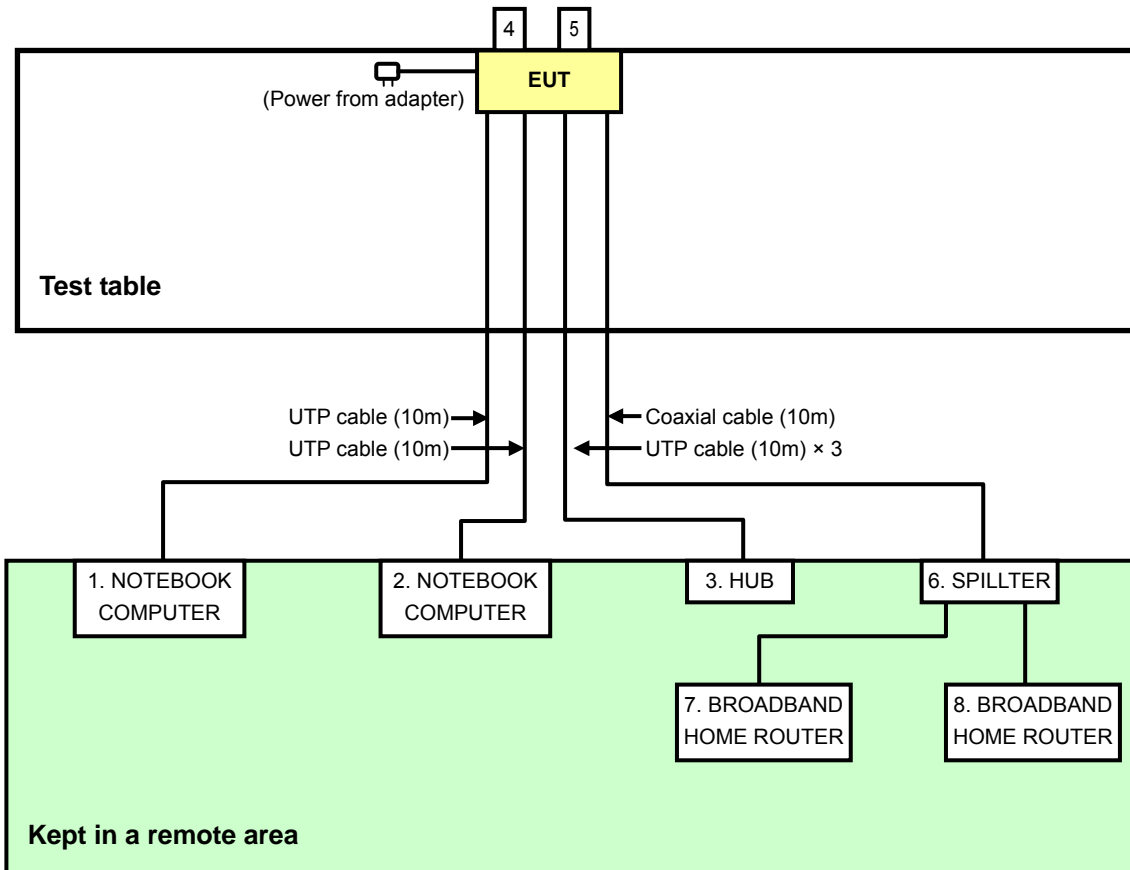

Note: Support units 4 & 5 are USB FLASH DISK.



A D T

4. TEST TYPES AND RESULTS

4.1 CONDUCTED EMISSION MEASUREMENT

4.1.1 LIMITS OF CONDUCTED EMISSION MEASUREMENT

FREQUENCY OF EMISSION (MHz)	CONDUCTED LIMIT (dB μ V)	
	Quasi-peak	Average
0.15-0.5	66 to 56	56 to 46
0.5-5	56	46
5-30	60	50

- NOTE:** 1. The lower limit shall apply at the transition frequencies.
2. The limit decreases in line with the logarithm of the frequency in the range of 0.15 to 0.50 MHz.

4.1.2 TEST INSTRUMENTS

DESCRIPTION & MANUFACTURER	MODEL NO.	SERIAL NO.	CALIBRATED DATE	CALIBRATED UNTIL
Test Receiver ROHDE & SCHWARZ	ESCS 30	100375	Mar. 08, 2013	Mar. 07, 2014
Line-Impedance Stabilization Network (for EUT) SCHWARZBECK	NSLK8127	8127-522	Sep. 05, 2013	Sep. 04, 2014
Line-Impedance Stabilization Network (for Peripheral)	ENV216	100072	June 06, 2013	June 05, 2014
RF Cable (JYEBAO)	5DFB	COCCAB-001	Mar. 11, 2013	Mar. 10, 2014
50 ohms Terminator	50	EMC-03	Sep. 24, 2013	Sep. 23, 2014
Software ADT	BV ADT_Cond_V7.3.7. 3	NA	NA	NA

Note:

1. The calibration interval of the above test instruments is 12 months and the calibrations are traceable to NML/ROC and NIST/USA.
2. The test was performed in Shielded Room No. C.
3. The VCCI Con C Registration No. is C-3611.
4. Tested Date: Dec. 27, 2013



A D T

4.1.3 TEST PROCEDURES

- a. The EUT was placed 0.4 meters from the conducting wall of the shielded room with EUT being connected to the power mains through a line impedance stabilization network (LISN). Other support units were connected to the power mains through another LISN.
- b. The two LISNs provide 50 ohm/ 50uH of coupling impedance for the measuring instrument.
- c. Both lines of the power mains connected to the EUT were checked for maximum conducted interference.
- d. The frequency range from 150kHz to 30MHz was searched. Emission level under (Limit – 20dB) was not recorded.

NOTE:

1. The resolution bandwidth of test receiver is 9kHz for Quasi-peak detection (QP) & Average detection (AV).

4.1.4 DEVIATION FROM TEST STANDARD

No deviation

4.1.5 TEST SETUP

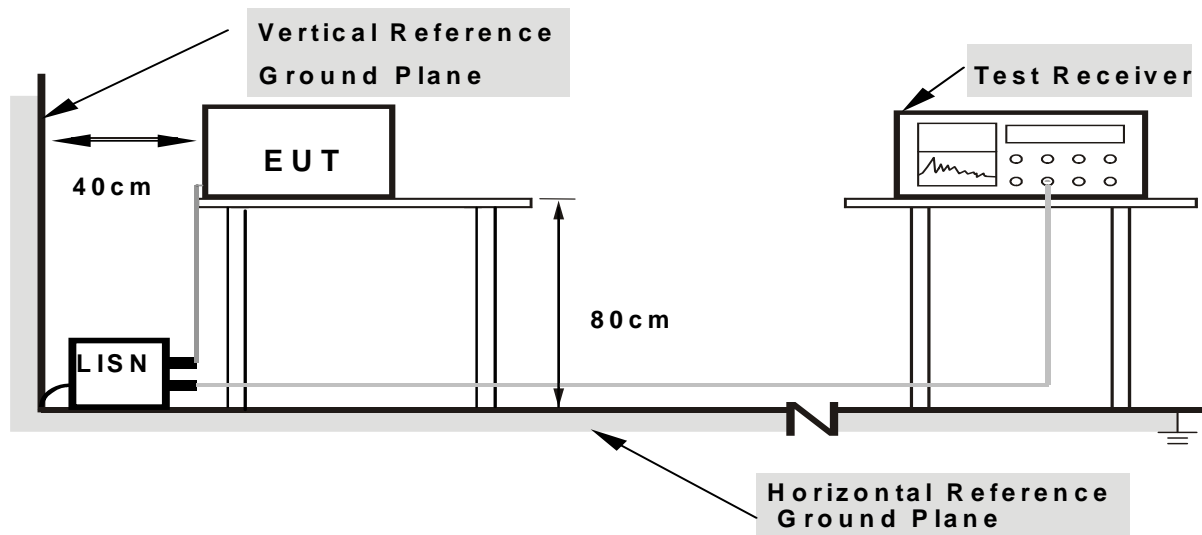

Note: 1.Support units were connected to second LISN.

For the actual test configuration, please refer to the related item – Photographs of the Test Configuration.

4.1.6 EUT OPERATING CONDITIONS

1. Placed the EUT on testing table.
2. Prepared computer system (support unit 1) to act as communication partner.
3. The communication partner run test program "BCMTool_BHR4_Greenwave.exe[v 1.0.11]" to enable EUT under transmission/receiving condition continuously at specific channel frequency.

4.1.7 TEST RESULTS (MODE 1)

PHASE	Line (L)	DETECTOR FUNCTION	Quasi-Peak (QP) / Average (AV)
--------------	----------	--------------------------	--------------------------------

No	Freq. [MHz]	Corr. Factor (dB)	Reading Value [dB (uV)]		Emission Level [dB (uV)]		Limit [dB (uV)]		Margin (dB)	
			Q.P.	AV.	Q.P.	AV.	Q.P.	AV.	Q.P.	AV.
1	0.16031	0.09	46.33	26.16	46.42	26.25	65.45	55.45	-19.02	-29.19
2	0.17127	0.10	40.52	18.74	40.62	18.84	64.90	54.90	-24.28	-36.06
3	0.21254	0.11	37.12	19.45	37.23	19.56	63.11	53.11	-25.87	-33.54
4	0.58385	0.17	35.54	23.02	35.71	23.19	56.00	46.00	-20.29	-22.81
5	0.98102	0.20	23.77	12.27	23.97	12.47	56.00	46.00	-32.03	-33.53
6	14.31457	0.92	37.26	29.84	38.18	30.76	60.00	50.00	-21.82	-19.24

REMARKS:

1. Q.P. and AV. are abbreviations of quasi-peak and average individually.
2. The emission levels of other frequencies were very low against the limit.
3. Margin value = Emission Level – Limit value
4. Correction Factor = Insertion loss + Cable loss
5. Emission Level = Correction Factor + Reading Value

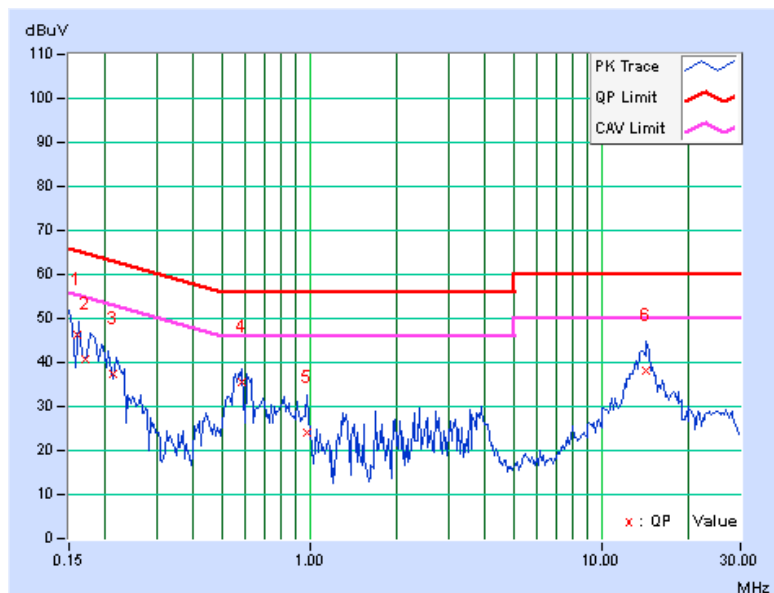

PHASE	Neutral (N)	DETECTOR FUNCTION	Quasi-Peak (QP) / Average (AV)
--------------	-------------	--------------------------	--------------------------------

No	Freq. [MHz]	Corr. Factor [dB]	Reading Value [dB (uV)]		Emission Level [dB (uV)]		Limit [dB (uV)]		Margin (dB)	
			Q.P.	AV.	Q.P.	AV.	Q.P.	AV.	Q.P.	AV.
1	0.15003	0.10	49.25	34.54	49.35	34.64	66.00	56.00	-16.65	-21.36
2	0.18526	0.11	42.02	26.12	42.13	26.23	64.25	54.25	-22.12	-28.02
3	0.22012	0.12	34.45	18.78	34.57	18.90	62.81	52.81	-28.25	-33.92
4	0.56457	0.17	34.71	27.45	34.88	27.62	56.00	46.00	-21.12	-18.38
5	13.33212	0.85	34.26	27.16	35.11	28.01	60.00	50.00	-24.89	-21.99
6	14.10358	0.88	38.38	31.44	39.26	32.32	60.00	50.00	-20.74	-17.68

REMARKS:

1. Q.P. and AV. are abbreviations of quasi-peak and average individually.
2. The emission levels of other frequencies were very low against the limit.
3. Margin value = Emission Level – Limit value
4. Correction Factor = Insertion loss + Cable loss
5. Emission Level = Correction Factor + Reading Value

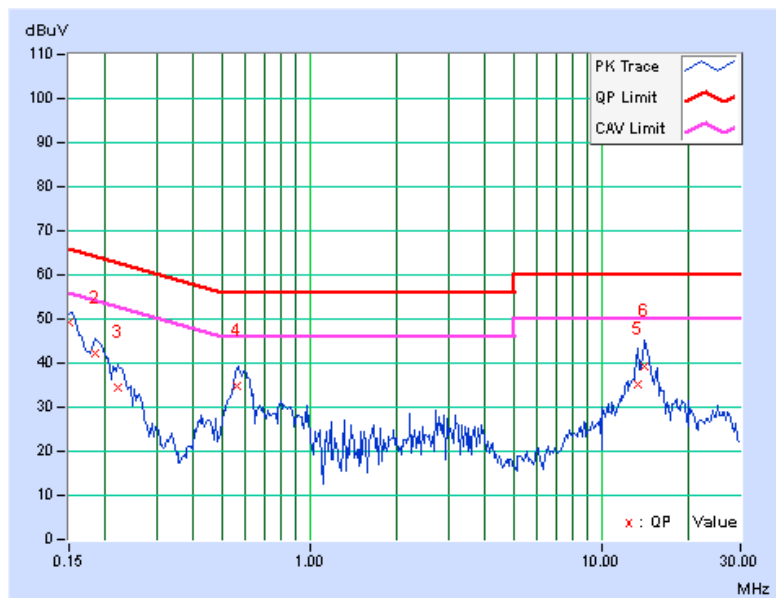

4.1.8 TEST RESULTS (MODE 2)

PHASE	Line (L)	DETECTOR FUNCTION	Quasi-Peak (QP) / Average (AV)
-------	----------	-------------------	--------------------------------

No	Freq. [MHz]	Corr. Factor [dB]	Reading Value [dB (uV)]		Emission Level [dB (uV)]		Limit [dB (uV)]		Margin [dB]	
			Q.P.	AV.	Q.P.	AV.	Q.P.	AV.	Q.P.	AV.
1	0.15011	0.10	51.12	38.45	51.22	38.55	65.99	55.99	-14.77	-17.44
2	0.18027	0.11	47.55	34.70	47.66	34.81	64.47	54.47	-16.82	-19.67
3	0.20102	0.11	43.21	27.45	43.32	27.56	63.57	53.57	-20.25	-26.01
4	0.21235	0.11	43.29	28.84	43.40	28.95	63.11	53.11	-19.71	-24.16
5	0.56659	0.17	32.20	27.74	32.37	27.91	56.00	46.00	-23.63	-18.09
6	8.71025	0.62	31.25	26.02	31.87	26.64	60.00	50.00	-28.13	-23.36

REMARKS:

1. Q.P. and AV. are abbreviations of quasi-peak and average individually.
2. The emission levels of other frequencies were very low against the limit.
3. Margin value = Emission Level – Limit value
4. Correction Factor = Insertion loss + Cable loss
5. Emission Level = Correction Factor + Reading Value

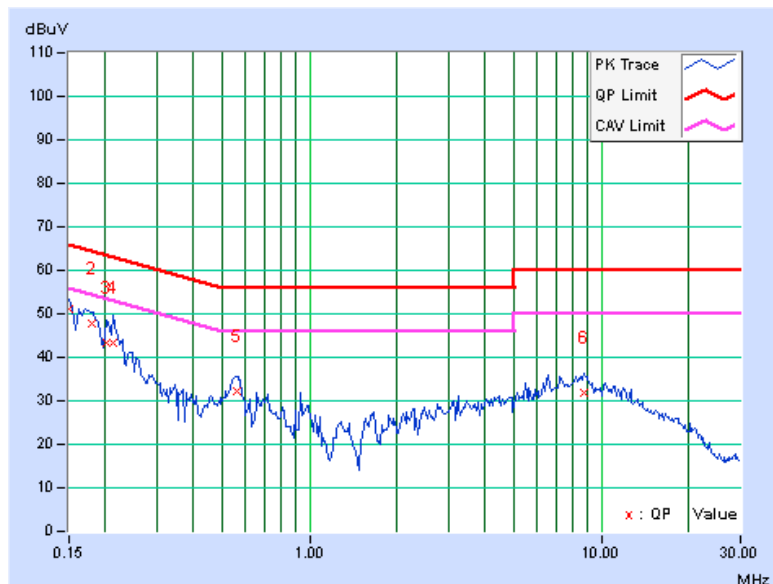

PHASE	Neutral (N)	DETECTOR FUNCTION	Quasi-Peak (QP) / Average (AV)
-------	-------------	-------------------	--------------------------------

No	Freq. [MHz]	Corr. Factor (dB)	Reading Value [dB (uV)]		Emission Level [dB (uV)]		Limit [dB (uV)]		Margin (dB)	
			Q.P.	AV.	Q.P.	AV.	Q.P.	AV.	Q.P.	AV.
1	0.15002	0.10	51.44	36.45	51.54	36.55	66.00	56.00	-14.46	-19.45
2	0.16869	0.10	47.12	31.38	47.22	31.48	65.02	55.02	-17.80	-23.54
3	0.18103	0.11	47.25	33.74	47.36	33.85	64.44	54.44	-17.08	-20.59
4	0.21226	0.11	42.54	29.15	42.65	29.26	63.12	53.12	-20.46	-23.85
5	0.55249	0.17	33.25	27.84	33.42	28.01	56.00	46.00	-22.58	-17.99
6	8.83659	0.63	31.68	26.22	32.31	26.85	60.00	50.00	-27.69	-23.15

REMARKS:

1. Q.P. and AV. are abbreviations of quasi-peak and average individually.
2. The emission levels of other frequencies were very low against the limit.
3. Margin value = Emission Level – Limit value
4. Correction Factor = Insertion loss + Cable loss
5. Emission Level = Correction Factor + Reading Value

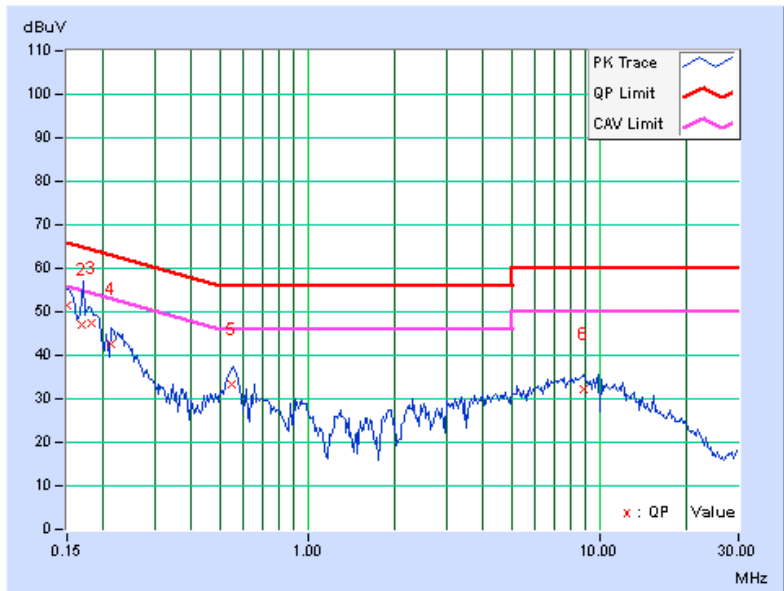

4.2 RADIATED EMISSION AND BANDEDGE MEASUREMENT

4.2.1 LIMITS OF RADIATED EMISSION AND BANDEDGE MEASUREMENT

Radiated emissions which fall in the restricted bands must comply with the radiated emission limits specified as below table:

Frequencies (MHz)	Field strength (microvolts/meter)	Measurement distance (meters)
0.009-0.490	2400/F(kHz)	300
0.490-1.705	24000/F(kHz)	30
1.705-30.0	30	30
30-88	100	3
88-216	150	3
216-960	200	3
Above 960	500	3

NOTE:

1. The lower limit shall apply at the transition frequencies.
2. Emission level (dBuV/m) = 20 log Emission level (uV/m).
3. For frequencies above 1000MHz, the field strength limits are based on average detector, however, the peak field strength of any emission shall not exceed the maximum permitted average limits, specified above by more than 20dB under any condition of modulation.

4.2.2 LIMITS OF UNWANTED EMISSION OUT OF THE RESTRICTED BANDS

APPLICABLE TO	LIMIT	
-	FIELD STRENGTH AT 3m (dBµV/m)	
	PK	AV
	74	54
√	EIRP LIMIT (dBm)	EQUIVALENT FIELD STRENGTH AT 3m (dBµV/m)
	PK	PK
	-27	68.3

NOTE:

1. The following formula is used to convert the equipment isotropic radiated power (eirp) to field strength:

$$E = \frac{1000000\sqrt{30P}}{3} \mu\text{V/m, where P is the eirp (Watts).}$$



A D T

4.2.3 TEST INSTRUMENTS

For below 1GHz:

DESCRIPTION & MANUFACTURER	MODEL NO.	SERIAL NO.	CALIBRATED DATE	CALIBRATED UNTIL
MXE EMI Receiver Agilent	N9038A	MY51210105	Jan. 21,2014	Jan. 20,2015
Pre-Amplifier Mini-Circuits	ZFL-1000VH2 B	AMP-ZFL-03	Nov. 13, 2013	Nov. 12, 2014
Trilog Broadband Antenna SCHWARZBECK	VULB 9168	9168-360	Mar. 19, 2013	Mar. 18, 2014
RF Cable	NA	CHGCAB_001	Oct. 05, 2013	Oct. 04, 2014
Spectrum Analyzer R&S	FSV40	100964	July 15, 2013	July 14, 2014
Horn_Antenna AISI	AIH.8018	0000320091110	Nov. 18, 2013	Nov. 17, 2014
Pre-Amplifier Agilent	8449B	3008A02578	June 25, 2013	June 24, 2014
RF Cable	NA	RF104-201 RF104-203 RF104-204	Dec. 12, 2013	Dec. 11, 2014
Spectrum Analyzer Agilent	E4446A	MY48250253	Aug. 28, 2013	Aug. 27, 2014
Pre-Amplifier SPACEK LABS	SLKKa-48-6	9K16	Nov. 13, 2013	Nov. 12, 2014
Horn_Antenna SCHWARZBECK	BBHA 9170	9170-424	Oct. 08, 2013	Oct. 07, 2014
Software	ADT_Radiated _V8.7.07	NA	NA	NA
Antenna Tower & Turn Table CT	NA	NA	NA	NA

Note:

1. The calibration interval of the above test instruments is 12 months and the calibrations are traceable to NML/ROC and NIST/USA.
2. The horn antenna, preamplifier (model: 8449B) are used only for the measurement of emission frequency above 1GHz if tested.
- 3 The test was performed in 966 Chamber No. G.
4. The FCC Site Registration No. is 966073.
- 5 The VCCI Site Registration No. is G-137.
- 6 The CANADA Site Registration No. is IC 7450H-2.
- 7 Tested Date: Feb. 20, 2014



A D T

For Above 1GHz:

DESCRIPTION & MANUFACTURER	MODEL NO.	SERIAL NO.	CALIBRATED DATE	CALIBRATED UNTIL
MXE EMI Receiver Agilent	N9038A	MY50010156	Jan. 15, 2014	Jan. 14, 2015
Pre-Amplifier Mini-Circuits	ZFL-1000VH2 B	AMP-ZFL-04	Nov. 13, 2013	Nov. 12, 2014
Trilog Broadband Antenna SCHWARZBECK	VULB 9168	9168-361	Feb. 27, 2014	Feb. 26, 2015
RF Cable	NA	CHHCAB_001	Oct. 06, 2013	Oct. 05, 2014
Spectrum Analyzer R&S	FSV40	100964	July 15, 2013	July 14, 2014
Horn_Antenna AISl	AIH.8018	0000220091110	Dec. 06, 2013	Dec. 05, 2014
Pre-Amplifier Agilent	8449B	3008A01923	Oct. 29, 2013	Oct. 28, 2014
RF Cable	NA	RF104-205 RF104-207 RF104-202	Dec. 12, 2013	Dec. 11, 2014
Spectrum Analyzer Agilent	E4446A	MY48250253	Aug. 28, 2013	Aug. 27, 2014
Pre-Amplifier SPACEK LABS	SLKKa-48-6	9K16	Nov. 13, 2013	Nov. 12, 2014
Horn_Antenna SCHWARZBECK	BBHA 9170	9170-424	Oct. 08, 2013	Oct. 07, 2014
Software	ADT_Radiated _V8.7.07	NA	NA	NA
Antenna Tower & Turn Table CT	NA	NA	NA	NA

Note:

1. The calibration interval of the above test instruments is 12 months and the calibrations are traceable to NML/ROC and NIST/USA.
2. The horn antenna, preamplifier (model: 8449B) are used only for the measurement of emission frequency above 1GHz if tested.
3. The test was performed in 966 Chamber No. H.
4. The FCC Site Registration No. is 797305.
5. The CANADA Site Registration No. is IC 7450H-3.
6. Tested Date: Apr. 23 to May 06, 2014



A D T

4.2.4 TEST PROCEDURES

- a. The EUT was placed on the top of a rotating table 0.8 meters above the ground at 3 meter chamber room for test. The table was rotated 360 degrees to determine the position of the highest radiation.
- b. The EUT was set 3 meters away from the interference-receiving antenna, which was mounted on the top of a variable-height antenna tower.
- c. The height of antenna is varied from one meter to four meters above the ground to determine the maximum value of the field strength. Both horizontal and vertical polarizations of the antenna are set to make the measurement.
- d. For each suspected emission, the EUT was arranged to its worst case and then the antenna was tuned to heights from 1 meter to 4 meters and the rotatable table was turned from 0 degrees to 360 degrees to find the maximum reading.
- e. The test-receiver system was set to quasi-peak detect function and specified bandwidth with maximum hold mode when the test frequency is below 1 GHz.
- f. The test-receiver system was set to peak and average detect function and specified bandwidth with maximum hold mode when the test frequency is above 1 GHz. If the peak reading value also meets average limit, measurement with the average detector is unnecessary.

NOTE:

1. The resolution bandwidth and video bandwidth of test receiver/spectrum analyzer is 120kHz for Quasi-peak detection (QP) at frequency below 1GHz.
2. The resolution bandwidth of test receiver/spectrum analyzer is 1 MHz and the video bandwidth is 3 MHz for Peak detection (PK) at frequency above 1GHz.
3. The resolution bandwidth of test receiver/spectrum analyzer is 1MHz and the video bandwidth is 3MHz for RMS Average (Duty cycle < 98%) for Average detection (AV) at frequency above 1GHz, then the measurement results was added to a correction factor ($10 \log(1/\text{duty cycle})$).
4. The resolution bandwidth of test receiver/spectrum analyzer is 1MHz and the video bandwidth is 10Hz (Duty cycle $\geq 98\%$) for Average detection (AV) at frequency above 1GHz.
5. All modes of operation were investigated and the worst-case emissions are reported.

4.2.5 DEVIATION FROM TEST STANDARD

No deviation

4.2.6 TEST SETUP

<Frequency Range below 1GHz>

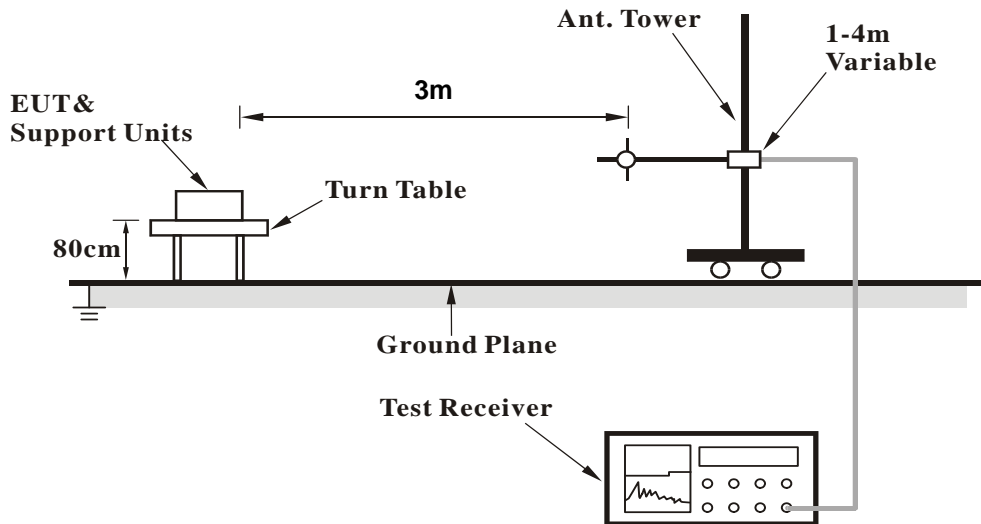

<Frequency Range above 1GHz>

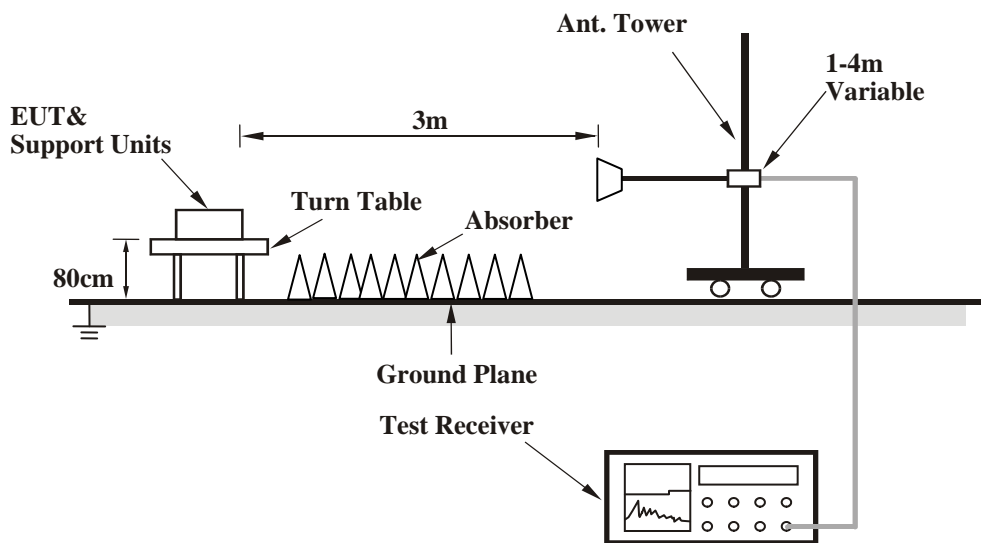

For the actual test configuration, please refer to the related item – Photographs of the Test Configuration.

4.2.7 EUT OPERATING CONDITION

Same as 4.1.6



A D T

4.2.8 TEST RESULTS (MODE 1)

CDD_MODE

ABOVE 1GHz DATA

802.11ac (VHT20)

CHANNEL	TX Channel 52	DETECTOR FUNCTION	Peak (PK)
FREQUENCY RANGE	1GHz ~ 40GHz		Average (AV)

ANTENNA POLARITY & TEST DISTANCE: HORIZONTAL AT 3 M

NO.	FREQ. (MHz)	EMISSION LEVEL (dBuV/m)	LIMIT (dBuV/m)	MARGIN (dB)	ANTENNA HEIGHT (m)	TABLE ANGLE (Degree)	RAW VALUE (dBuV)	CORRECTION FACTOR (dB/m)
1	*5260.00	103.1 PK			1.02 H	0	98.70	4.40
2	*5260.00	92.5 AV			1.02 H	0	88.10	4.40
3	5380.00	57.9 PK	74.0	-16.1	1.09 H	360	53.20	4.70
4	5380.00	45.1 AV	54.0	-8.9	1.09 H	360	40.40	4.70
5	5420.00	60.0 PK	74.0	-14.0	1.09 H	0	55.40	4.60
6	5420.00	47.7 AV	54.0	-6.3	1.09 H	0	43.10	4.60
7	#5670.00	60.5 PK	68.3	-7.8	1.03 H	0	55.60	4.90
8	#10520.00	56.3 PK	68.3	-12.0	1.11 H	247	45.90	10.40
9	15780.00	60.3 PK	74.0	-13.7	1.03 H	108	45.60	14.70
10	15780.00	47.9 AV	54.0	-6.1	1.03 H	108	33.20	14.70

ANTENNA POLARITY & TEST DISTANCE: VERTICAL AT 3 M

NO.	FREQ. (MHz)	EMISSION LEVEL (dBuV/m)	LIMIT (dBuV/m)	MARGIN (dB)	ANTENNA HEIGHT (m)	TABLE ANGLE (Degree)	RAW VALUE (dBuV)	CORRECTION FACTOR (dB/m)
1	*5260.00	107.4 PK			1.19 V	269	103.00	4.40
2	*5260.00	97.1 AV			1.19 V	269	92.70	4.40
3	5380.00	59.4 PK	74.0	-14.6	1.08 V	211	54.70	4.70
4	5380.00	47.4 AV	54.0	-6.6	1.08 V	211	42.70	4.70
5	5420.00	63.5 PK	74.0	-10.5	1.07 V	211	58.90	4.60
6	5420.00	53.6 AV	54.0	-0.4	1.07 V	211	49.00	4.60
7	#5670.00	58.7 PK	68.3	-9.6	1.00 V	125	53.80	4.90
8	#10520.00	58.3 PK	68.3	-10.0	1.05 V	291	47.90	10.40
9	15780.00	58.8 PK	74.0	-15.2	1.05 V	217	44.10	14.70
10	15780.00	43.0 AV	54.0	-11.0	1.05 V	217	28.30	14.70

REMARKS:

1. Emission Level(dBuV/m) = Raw Value(dBuV) + Correction Factor(dB/m)
2. Correction Factor(dB/m) = Antenna Factor(dB/m) + Cable Factor(dB) – Pre-Amplifier Factor(dB)
3. The other emission levels were very low against the limit.
4. Margin value = Emission Level – Limit value
5. " * ": Fundamental frequency.
6. " # ": The radiated frequency is out of the restricted band.



A D T

CHANNEL	TX Channel 60	DETECTOR FUNCTION	Peak (PK)
FREQUENCY RANGE	1GHz ~ 40GHz		Average (AV)

ANTENNA POLARITY & TEST DISTANCE: HORIZONTAL AT 3 M

NO.	FREQ. (MHz)	EMISSION LEVEL (dBuV/m)	LIMIT (dBuV/m)	MARGIN (dB)	ANTENNA HEIGHT (m)	TABLE ANGLE (Degree)	RAW VALUE (dBuV)	CORRECTION FACTOR (dB/m)
1	*5300.00	103.5 PK			1.40 H	185	99.10	4.40
2	*5300.00	92.4 AV			1.40 H	185	88.00	4.40
3	5380.00	61.1 PK	74.0	-12.9	1.27 H	190	56.40	4.70
4	5380.00	50.2 AV	54.0	-3.8	1.27 H	190	45.50	4.70
5	10600.00	56.4 PK	74.0	-17.6	1.09 H	262	45.80	10.60
6	10600.00	42.8 AV	54.0	-11.2	1.09 H	262	32.20	10.60
7	15900.00	60.7 PK	74.0	-13.3	1.00 H	121	45.60	15.10
8	15900.00	48.0 AV	54.0	-6.0	1.00 H	121	32.90	15.10

ANTENNA POLARITY & TEST DISTANCE: VERTICAL AT 3 M

NO.	FREQ. (MHz)	EMISSION LEVEL (dBuV/m)	LIMIT (dBuV/m)	MARGIN (dB)	ANTENNA HEIGHT (m)	TABLE ANGLE (Degree)	RAW VALUE (dBuV)	CORRECTION FACTOR (dB/m)
1	*5300.00	106.3 PK			1.44 V	190	101.90	4.40
2	*5300.00	96.5 AV			1.44 V	190	92.10	4.40
3	5380.00	64.0 PK	74.0	-10.0	1.42 V	191	59.30	4.70
4	5380.00	53.4 AV	54.0	-0.6	1.42 V	191	48.70	4.70
5	10600.00	58.4 PK	74.0	-15.6	1.08 V	301	47.80	10.60
6	10600.00	42.7 AV	54.0	-11.3	1.08 V	301	32.10	10.60
7	15900.00	58.6 PK	74.0	-15.4	1.07 V	216	43.50	15.10
8	15900.00	43.1 AV	54.0	-10.9	1.07 V	216	28.00	15.10

REMARKS:

1. Emission Level(dBuV/m) = Raw Value(dBuV) + Correction Factor(dB/m)
2. Correction Factor(dB/m) = Antenna Factor(dB/m) + Cable Factor(dB) – Pre-Amplifier Factor(dB)
3. The other emission levels were very low against the limit.
4. Margin value = Emission Level – Limit value
5. " * ": Fundamental frequency.



A D T

CHANNEL	TX Channel 64	DETECTOR FUNCTION	Peak (PK)
FREQUENCY RANGE	1GHz ~ 40GHz		Average (AV)

ANTENNA POLARITY & TEST DISTANCE: HORIZONTAL AT 3 M

NO.	FREQ. (MHz)	EMISSION LEVEL (dBuV/m)	LIMIT (dBuV/m)	MARGIN (dB)	ANTENNA HEIGHT (m)	TABLE ANGLE (Degree)	RAW VALUE (dBuV)	CORRECTION FACTOR (dB/m)
1	*5320.00	102.8 PK			1.00 H	357	98.40	4.40
2	*5320.00	92.4 AV			1.00 H	357	88.00	4.40
3	5400.00	63.7 PK	74.0	-10.3	1.10 H	357	59.00	4.70
4	5400.00	52.0 AV	54.0	-2.0	1.10 H	357	47.30	4.70
5	10640.00	56.7 PK	74.0	-17.3	1.05 H	247	46.10	10.60
6	10640.00	43.0 AV	54.0	-11.0	1.05 H	247	32.40	10.60
7	15960.00	60.3 PK	74.0	-13.7	1.00 H	135	45.40	14.90
8	15960.00	47.8 AV	54.0	-6.2	1.00 H	135	32.90	14.90

ANTENNA POLARITY & TEST DISTANCE: VERTICAL AT 3 M

NO.	FREQ. (MHz)	EMISSION LEVEL (dBuV/m)	LIMIT (dBuV/m)	MARGIN (dB)	ANTENNA HEIGHT (m)	TABLE ANGLE (Degree)	RAW VALUE (dBuV)	CORRECTION FACTOR (dB/m)
1	*5320.00	106.8 PK			1.20 V	172	102.40	4.40
2	*5320.00	96.9 AV			1.20 V	172	92.50	4.40
3	5400.00	65.0 PK	74.0	-9.0	1.18 V	198	60.30	4.70
4	5400.00	53.5 AV	54.0	-0.5	1.18 V	198	48.80	4.70
5	10640.00	58.4 PK	74.0	-15.6	1.08 V	293	47.80	10.60
6	10640.00	42.8 AV	54.0	-11.2	1.08 V	293	32.20	10.60
7	15960.00	59.2 PK	74.0	-14.8	1.11 V	203	44.30	14.90
8	15960.00	43.5 AV	54.0	-10.5	1.11 V	203	28.60	14.90

REMARKS:

1. Emission Level(dBuV/m) = Raw Value(dBuV) + Correction Factor(dB/m)
2. Correction Factor(dB/m) = Antenna Factor(dB/m) + Cable Factor(dB) – Pre-Amplifier Factor(dB)
3. The other emission levels were very low against the limit.
4. Margin value = Emission Level – Limit value
5. " * ": Fundamental frequency.



A D T

CHANNEL	TX Channel 100	DETECTOR FUNCTION	Peak (PK)
FREQUENCY RANGE	1GHz ~ 40GHz		Average (AV)

ANTENNA POLARITY & TEST DISTANCE: HORIZONTAL AT 3 M

NO.	FREQ. (MHz)	EMISSION LEVEL (dBuV/m)	LIMIT (dBuV/m)	MARGIN (dB)	ANTENNA HEIGHT (m)	TABLE ANGLE (Degree)	RAW VALUE (dBuV)	CORRECTION FACTOR (dB/m)
1	5420.00	64.3 PK	74.0	-9.7	1.08 H	1	59.70	4.60
2	5420.00	52.8 AV	54.0	-1.2	1.08 H	1	48.20	4.60
3	*5500.00	103.1 PK			1.07 H	355	98.50	4.60
4	*5500.00	93.1 AV			1.07 H	355	88.50	4.60
5	11000.00	56.3 PK	74.0	-17.7	1.04 H	248	45.50	10.80
6	11000.00	42.7 AV	54.0	-11.3	1.04 H	248	31.90	10.80
7	#16500.00	60.6 PK	68.3	-7.7	1.00 H	135	43.60	17.00

ANTENNA POLARITY & TEST DISTANCE: VERTICAL AT 3 M

NO.	FREQ. (MHz)	EMISSION LEVEL (dBuV/m)	LIMIT (dBuV/m)	MARGIN (dB)	ANTENNA HEIGHT (m)	TABLE ANGLE (Degree)	RAW VALUE (dBuV)	CORRECTION FACTOR (dB/m)
1	5420.00	63.9 PK	74.0	-10.1	1.17 V	204	59.30	4.60
2	5420.00	53.3 AV	54.0	-0.7	1.17 V	204	48.70	4.60
3	*5500.00	109.5 PK			1.16 V	208	104.90	4.60
4	*5500.00	98.8 AV			1.16 V	208	94.20	4.60
5	11000.00	58.7 PK	74.0	-15.3	1.11 V	281	47.90	10.80
6	11000.00	42.9 AV	54.0	-11.1	1.11 V	281	32.10	10.80
7	#16500.00	59.3 PK	68.3	-9.0	1.14 V	198	42.30	17.00

REMARKS:

1. Emission Level(dBuV/m) = Raw Value(dBuV) + Correction Factor(dB/m)
2. Correction Factor(dB/m) = Antenna Factor(dB/m) + Cable Factor(dB) – Pre-Amplifier Factor(dB)
3. The other emission levels were very low against the limit.
4. Margin value = Emission Level – Limit value
5. " * ": Fundamental frequency.
6. " # ": The radiated frequency is out of the restricted band.



A D T

CHANNEL	TX Channel 116	DETECTOR FUNCTION	Peak (PK)
FREQUENCY RANGE	1GHz ~ 40GHz		Average (AV)

ANTENNA POLARITY & TEST DISTANCE: HORIZONTAL AT 3 M

NO.	FREQ. (MHz)	EMISSION LEVEL (dBuV/m)	LIMIT (dBuV/m)	MARGIN (dB)	ANTENNA HEIGHT (m)	TABLE ANGLE (Degree)	RAW VALUE (dBuV)	CORRECTION FACTOR (dB/m)
1	#5347.00	53.8 PK	68.3	-14.5	1.00 H	335	49.40	4.40
2	5420.00	56.7 PK	74.0	-17.3	1.09 H	329	52.10	4.60
3	5420.00	45.6 AV	54.0	-8.4	1.09 H	329	41.00	4.60
4	*5580.00	106.0 PK			1.00 H	284	101.10	4.90
5	*5580.00	96.6 AV			1.00 H	284	91.70	4.90
6	#5740.00	59.5 PK	68.3	-8.8	1.00 H	348	54.60	4.90
7	11160.00	56.7 PK	74.0	-17.3	1.34 H	138	46.00	10.70
8	11160.00	43.5 AV	54.0	-10.5	1.34 H	138	32.80	10.70
9	#16740.00	61.0 PK	68.3	-7.3	1.00 H	140	43.10	17.90

ANTENNA POLARITY & TEST DISTANCE: VERTICAL AT 3 M

NO.	FREQ. (MHz)	EMISSION LEVEL (dBuV/m)	LIMIT (dBuV/m)	MARGIN (dB)	ANTENNA HEIGHT (m)	TABLE ANGLE (Degree)	RAW VALUE (dBuV)	CORRECTION FACTOR (dB/m)
1	#5347.00	61.1 PK	68.3	-7.2	1.31 V	99	56.70	4.40
2	5420.00	62.7 PK	74.0	-11.3	1.28 V	94	58.10	4.60
3	5420.00	51.3 AV	54.0	-2.7	1.28 V	94	46.70	4.60
4	*5580.00	111.7 PK			1.00 V	274	106.80	4.90
5	*5580.00	102.1 AV			1.00 V	274	97.20	4.90
6	#5740.00	68.0 PK	68.3	-0.3	1.31 V	95	63.10	4.90
7	11160.00	55.3 PK	74.0	-18.7	1.28 V	89	44.60	10.70
8	11160.00	42.7 AV	54.0	-11.3	1.28 V	89	32.00	10.70
9	#16740.00	59.4 PK	68.3	-8.9	1.08 V	193	41.50	17.90

REMARKS:

1. Emission Level(dBuV/m) = Raw Value(dBuV) + Correction Factor(dB/m)
2. Correction Factor(dB/m) = Antenna Factor(dB/m) + Cable Factor(dB) – Pre-Amplifier Factor(dB)
3. The other emission levels were very low against the limit.
4. Margin value = Emission Level – Limit value
5. " * " : Fundamental frequency.
6. " # " : The radiated frequency is out of the restricted band.



A D T

CHANNEL	TX Channel 132	DETECTOR FUNCTION	Peak (PK)
FREQUENCY RANGE	1GHz ~ 40GHz		Average (AV)

ANTENNA POLARITY & TEST DISTANCE: HORIZONTAL AT 3 M

NO.	FREQ. (MHz)	EMISSION LEVEL (dBuV/m)	LIMIT (dBuV/m)	MARGIN (dB)	ANTENNA HEIGHT (m)	TABLE ANGLE (Degree)	RAW VALUE (dBuV)	CORRECTION FACTOR (dB/m)
1	*5660.00	114.2 PK			1.00 H	279	109.30	4.90
2	*5660.00	94.3 AV			1.00 H	279	89.40	4.90
3	#5740.00	63.5 PK	68.3	-4.8	1.01 H	355	58.60	4.90
4	11320.00	56.3 PK	74.0	-17.7	1.29 H	146	45.50	10.80
5	11320.00	43.2 AV	54.0	-10.8	1.29 H	146	32.40	10.80
6	#16980.00	60.4 PK	68.3	-7.9	1.03 H	137	42.00	18.40

ANTENNA POLARITY & TEST DISTANCE: VERTICAL AT 3 M

NO.	FREQ. (MHz)	EMISSION LEVEL (dBuV/m)	LIMIT (dBuV/m)	MARGIN (dB)	ANTENNA HEIGHT (m)	TABLE ANGLE (Degree)	RAW VALUE (dBuV)	CORRECTION FACTOR (dB/m)
1	*5660.00	110.6 PK			1.14 V	169	105.70	4.90
2	*5660.00	100.3 AV			1.14 V	169	95.40	4.90
3	#5740.00	68.0 PK	68.3	-0.3	1.33 V	175	63.10	4.90
4	11320.00	55.1 PK	74.0	-18.9	1.31 V	86	44.30	10.80
5	11320.00	42.6 AV	54.0	-11.4	1.31 V	86	31.80	10.80
6	#16980.00	59.6 PK	68.3	-8.7	1.04 V	182	41.20	18.40

REMARKS:

1. Emission Level(dBuV/m) = Raw Value(dBuV) + Correction Factor(dB/m)
2. Correction Factor(dB/m) = Antenna Factor(dB/m) + Cable Factor(dB) – Pre-Amplifier Factor(dB)
3. The other emission levels were very low against the limit.
4. Margin value = Emission Level – Limit value
5. " * ": Fundamental frequency.
6. " # ": The radiated frequency is out of the restricted band.



A D T

CHANNEL	TX Channel 140	DETECTOR FUNCTION	Peak (PK)
FREQUENCY RANGE	1GHz ~ 40GHz		Average (AV)

ANTENNA POLARITY & TEST DISTANCE: HORIZONTAL AT 3 M

NO.	FREQ. (MHz)	EMISSION LEVEL (dBuV/m)	LIMIT (dBuV/m)	MARGIN (dB)	ANTENNA HEIGHT (m)	TABLE ANGLE (Degree)	RAW VALUE (dBuV)	CORRECTION FACTOR (dB/m)
1	*5700.00	112.4 PK			1.02 H	284	107.50	4.90
2	*5700.00	93.1 AV			1.02 H	284	88.20	4.90
3	#5780.00	61.5 PK	68.3	-6.8	1.18 H	358	56.60	4.90
4	#5860.00	56.5 PK	68.3	-11.8	1.13 H	68	51.40	5.10
5	11400.00	56.0 PK	74.0	-18.0	1.28 H	159	45.30	10.70
6	11400.00	43.2 AV	54.0	-10.8	1.28 H	159	32.50	10.70
7	#17100.00	60.0 PK	68.3	-8.3	1.06 H	122	41.40	18.60

ANTENNA POLARITY & TEST DISTANCE: VERTICAL AT 3 M

NO.	FREQ. (MHz)	EMISSION LEVEL (dBuV/m)	LIMIT (dBuV/m)	MARGIN (dB)	ANTENNA HEIGHT (m)	TABLE ANGLE (Degree)	RAW VALUE (dBuV)	CORRECTION FACTOR (dB/m)
1	*5700.00	108.6 PK			1.03 V	151	103.70	4.90
2	*5700.00	98.9 AV			1.03 V	151	94.00	4.90
3	#5780.00	67.9 PK	68.3	-0.4	1.10 V	199	63.00	4.90
4	#5860.00	65.0 PK	68.3	-3.3	1.18 V	206	59.90	5.10
5	11400.00	55.0 PK	74.0	-19.0	1.25 V	82	44.30	10.70
6	11400.00	42.3 AV	54.0	-11.7	1.25 V	82	31.60	10.70
7	#17100.00	59.3 PK	68.3	-9.0	1.02 V	167	40.70	18.60

REMARKS:

1. Emission Level(dBuV/m) = Raw Value(dBuV) + Correction Factor(dB/m)
2. Correction Factor(dB/m) = Antenna Factor(dB/m) + Cable Factor(dB) – Pre-Amplifier Factor(dB)
3. The other emission levels were very low against the limit.
4. Margin value = Emission Level – Limit value
5. " * ": Fundamental frequency.
6. " # ": The radiated frequency is out of the restricted band.



A D T

CHANNEL	TX Channel 144	DETECTOR FUNCTION	Peak (PK)
FREQUENCY RANGE	1GHz ~ 40GHz		Average (AV)

ANTENNA POLARITY & TEST DISTANCE: HORIZONTAL AT 3 M

NO.	FREQ. (MHz)	EMISSION LEVEL (dBuV/m)	LIMIT (dBuV/m)	MARGIN (dB)	ANTENNA HEIGHT (m)	TABLE ANGLE (Degree)	RAW VALUE (dBuV)	CORRECTION FACTOR (dB/m)
1	*5720.00	113.1 PK			1.00 H	354	108.20	4.90
2	*5720.00	103.0 AV			1.00 H	354	98.10	4.90
3	#5881.00	61.1 PK	68.3	-7.2	1.00 H	56	56.00	5.10
4	11440.00	60.0 PK	74.0	-14.0	1.00 H	136	49.40	10.60
5	11440.00	47.4 AV	54.0	-6.6	1.00 H	136	36.80	10.60
6	#17160.00	59.5 PK	68.3	-8.8	1.04 H	133	40.40	19.10

ANTENNA POLARITY & TEST DISTANCE: VERTICAL AT 3 M

NO.	FREQ. (MHz)	EMISSION LEVEL (dBuV/m)	LIMIT (dBuV/m)	MARGIN (dB)	ANTENNA HEIGHT (m)	TABLE ANGLE (Degree)	RAW VALUE (dBuV)	CORRECTION FACTOR (dB/m)
1	*5720.00	113.5 PK			1.00 V	252	108.60	4.90
2	*5720.00	104.5 AV			1.00 V	252	99.60	4.90
3	#5881.00	68.1 PK	68.3	-0.2	1.11 V	95	63.00	5.10
4	11440.00	56.5 PK	74.0	-17.5	1.24 V	91	45.90	10.60
5	11440.00	43.7 AV	54.0	-10.3	1.24 V	91	33.10	10.60
6	#17160.00	59.5 PK	68.3	-8.8	1.04 V	174	40.40	19.10

REMARKS:

1. Emission Level(dBuV/m) = Raw Value(dBuV) + Correction Factor(dB/m)
2. Correction Factor(dB/m) = Antenna Factor(dB/m) + Cable Factor(dB) – Pre-Amplifier Factor(dB)
3. The other emission levels were very low against the limit.
4. Margin value = Emission Level – Limit value
5. " * ": Fundamental frequency.
6. " # ": The radiated frequency is out of the restricted band.



A D T

802.11ac (VHT40)

CHANNEL	TX Channel 54	DETECTOR FUNCTION	Peak (PK)
FREQUENCY RANGE	1GHz ~ 40GHz		Average (AV)

ANTENNA POLARITY & TEST DISTANCE: HORIZONTAL AT 3 M

NO.	FREQ. (MHz)	EMISSION LEVEL (dBuV/m)	LIMIT (dBuV/m)	MARGIN (dB)	ANTENNA HEIGHT (m)	TABLE ANGLE (Degree)	RAW VALUE (dBuV)	CORRECTION FACTOR (dB/m)
1	*5270.00	106.2 PK			1.11 H	348	101.90	4.30
2	*5270.00	95.5 AV			1.11 H	348	91.20	4.30
3	5360.00	63.4 PK	74.0	-10.6	1.00 H	360	58.90	4.50
4	5360.00	52.5 AV	54.0	-1.5	1.00 H	360	48.00	4.50
5	5430.00	58.4 PK	74.0	-15.6	1.19 H	14	53.70	4.70
6	5430.00	45.1 AV	54.0	-8.9	1.19 H	14	40.40	4.70
7	#10540.00	55.9 PK	68.3	-12.4	1.24 H	157	45.50	10.40
8	15810.00	60.5 PK	74.0	-13.5	1.07 H	135	45.70	14.80
9	15810.00	47.8 AV	54.0	-6.2	1.07 H	135	33.00	14.80

ANTENNA POLARITY & TEST DISTANCE: VERTICAL AT 3 M

NO.	FREQ. (MHz)	EMISSION LEVEL (dBuV/m)	LIMIT (dBuV/m)	MARGIN (dB)	ANTENNA HEIGHT (m)	TABLE ANGLE (Degree)	RAW VALUE (dBuV)	CORRECTION FACTOR (dB/m)
1	*5270.00	108.3 PK			1.02 V	135	104.00	4.30
2	*5270.00	97.9 AV			1.02 V	135	93.60	4.30
3	5360.00	64.3 PK	74.0	-9.7	1.01 V	134	59.80	4.50
4	5360.00	53.1 AV	54.0	-0.9	1.01 V	134	48.60	4.50
5	5430.00	62.5 PK	74.0	-11.5	1.00 V	134	57.80	4.70
6	5430.00	52.0 AV	54.0	-2.0	1.00 V	134	47.30	4.70
7	#10540.00	55.9 PK	68.3	-12.4	1.23 V	85	45.50	10.40
8	15810.00	59.9 PK	74.0	-14.1	1.00 V	161	45.10	14.80
9	15810.00	43.8 AV	54.0	-10.2	1.00 V	161	29.00	14.80

REMARKS:

1. Emission Level(dBuV/m) = Raw Value(dBuV) + Correction Factor(dB/m)
2. Correction Factor(dB/m) = Antenna Factor(dB/m) + Cable Factor(dB) – Pre-Amplifier Factor(dB)
3. The other emission levels were very low against the limit.
4. Margin value = Emission Level – Limit value
5. " * ": Fundamental frequency.
6. " # ": The radiated frequency is out of the restricted band.



A D T

CHANNEL	TX Channel 62	DETECTOR FUNCTION	Peak (PK)
FREQUENCY RANGE	1GHz ~ 40GHz		Average (AV)

ANTENNA POLARITY & TEST DISTANCE: HORIZONTAL AT 3 M

NO.	FREQ. (MHz)	EMISSION LEVEL (dBuV/m)	LIMIT (dBuV/m)	MARGIN (dB)	ANTENNA HEIGHT (m)	TABLE ANGLE (Degree)	RAW VALUE (dBuV)	CORRECTION FACTOR (dB/m)
1	*5310.00	105.6 PK			1.10 H	335	101.20	4.40
2	*5310.00	95.8 AV			1.10 H	335	91.40	4.40
3	5350.00	64.3 PK	74.0	-9.7	1.06 H	358	59.90	4.40
4	5350.00	49.2 AV	54.0	-4.8	1.06 H	358	44.80	4.40
5	#5470.00	56.5 PK	68.3	-11.8	1.05 H	360	51.90	4.60
6	10620.00	56.0 PK	74.0	-18.0	1.20 H	162	45.40	10.60
7	10620.00	43.3 AV	54.0	-10.7	1.20 H	162	32.70	10.60
8	15930.00	60.0 PK	74.0	-14.0	1.11 H	145	45.10	14.90
9	15930.00	47.6 AV	54.0	-6.4	1.11 H	145	32.70	14.90

ANTENNA POLARITY & TEST DISTANCE: VERTICAL AT 3 M

NO.	FREQ. (MHz)	EMISSION LEVEL (dBuV/m)	LIMIT (dBuV/m)	MARGIN (dB)	ANTENNA HEIGHT (m)	TABLE ANGLE (Degree)	RAW VALUE (dBuV)	CORRECTION FACTOR (dB/m)
1	*5310.00	107.9 PK			1.00 V	136	103.50	4.40
2	*5310.00	98.0 AV			1.00 V	136	93.60	4.40
3	5350.00	66.5 PK	74.0	-7.5	1.00 V	134	62.10	4.40
4	5350.00	53.5 AV	54.0	-0.5	1.00 V	134	49.10	4.40
5	#5470.00	64.4 PK	68.3	-3.9	1.07 V	146	59.80	4.60
6	10620.00	56.2 PK	74.0	-17.8	1.25 V	94	45.60	10.60
7	10620.00	43.5 AV	54.0	-10.5	1.25 V	94	32.90	10.60
8	15930.00	59.8 PK	74.0	-14.2	1.00 V	157	44.90	14.90
9	15930.00	43.6 AV	54.0	-10.4	1.00 V	157	28.70	14.90

REMARKS:

1. Emission Level(dBuV/m) = Raw Value(dBuV) + Correction Factor(dB/m)
2. Correction Factor(dB/m) = Antenna Factor(dB/m) + Cable Factor(dB) – Pre-Amplifier Factor(dB)
3. The other emission levels were very low against the limit.
4. Margin value = Emission Level – Limit value
5. " * " : Fundamental frequency.
6. " # " : The radiated frequency is out of the restricted band.



A D T

CHANNEL	TX Channel 102	DETECTOR FUNCTION	Peak (PK)
FREQUENCY RANGE	1GHz ~ 40GHz		Average (AV)

ANTENNA POLARITY & TEST DISTANCE: HORIZONTAL AT 3 M

NO.	FREQ. (MHz)	EMISSION LEVEL (dBuV/m)	LIMIT (dBuV/m)	MARGIN (dB)	ANTENNA HEIGHT (m)	TABLE ANGLE (Degree)	RAW VALUE (dBuV)	CORRECTION FACTOR (dB/m)
1	5050.00	52.2 PK	74.0	-21.8	1.00 H	105	48.20	4.00
2	5050.00	42.5 AV	54.0	-11.5	1.00 H	105	38.50	4.00
3	5350.00	61.1 PK	74.0	-12.9	1.07 H	2	56.70	4.40
4	5350.00	44.0 AV	54.0	-10.0	1.07 H	2	39.60	4.40
5	5430.00	67.2 PK	74.0	-6.8	1.06 H	353	62.50	4.70
6	5430.00	50.0 AV	54.0	-4.0	1.06 H	353	45.30	4.70
7	*5510.00	105.4 PK			1.08 H	343	100.80	4.60
8	*5510.00	95.7 AV			1.08 H	343	91.10	4.60
9	11020.00	55.8 PK	74.0	-18.2	1.19 H	151	45.00	10.80
10	11020.00	42.9 AV	54.0	-11.1	1.19 H	151	32.10	10.80
11	#16530.00	59.7 PK	68.3	-8.6	1.11 H	130	42.60	17.10

ANTENNA POLARITY & TEST DISTANCE: VERTICAL AT 3 M

NO.	FREQ. (MHz)	EMISSION LEVEL (dBuV/m)	LIMIT (dBuV/m)	MARGIN (dB)	ANTENNA HEIGHT (m)	TABLE ANGLE (Degree)	RAW VALUE (dBuV)	CORRECTION FACTOR (dB/m)
1	5050.00	59.2 PK	74.0	-14.8	1.05 V	205	55.20	4.00
2	5050.00	51.7 AV	54.0	-2.3	1.05 V	205	47.70	4.00
3	5350.00	61.7 PK	74.0	-12.3	1.00 V	134	57.30	4.40
4	5350.00	48.6 AV	54.0	-5.4	1.00 V	134	44.20	4.40
5	5430.00	64.3 PK	74.0	-9.7	1.29 V	206	59.60	4.70
6	5430.00	53.7 AV	54.0	-0.3	1.29 V	206	49.00	4.70
7	*5510.00	107.9 PK			1.35 V	270	103.30	4.60
8	*5510.00	97.8 AV			1.35 V	270	93.20	4.60
9	11020.00	56.2 PK	74.0	-17.8	1.29 V	101	45.40	10.80
10	11020.00	43.4 AV	54.0	-10.6	1.29 V	101	32.60	10.80
11	#16530.00	60.1 PK	68.3	-8.2	1.00 V	141	43.00	17.10

REMARKS:

1. Emission Level(dBuV/m) = Raw Value(dBuV) + Correction Factor(dB/m)
2. Correction Factor(dB/m) = Antenna Factor(dB/m) + Cable Factor(dB) – Pre-Amplifier Factor(dB)
3. The other emission levels were very low against the limit.
4. Margin value = Emission Level – Limit value
5. " * ": Fundamental frequency.
6. " # ": The radiated frequency is out of the restricted band.



A D T

CHANNEL	TX Channel 110	DETECTOR FUNCTION	Peak (PK)
FREQUENCY RANGE	1GHz ~ 40GHz		Average (AV)

ANTENNA POLARITY & TEST DISTANCE: HORIZONTAL AT 3 M

NO.	FREQ. (MHz)	EMISSION LEVEL (dBuV/m)	LIMIT (dBuV/m)	MARGIN (dB)	ANTENNA HEIGHT (m)	TABLE ANGLE (Degree)	RAW VALUE (dBuV)	CORRECTION FACTOR (dB/m)
1	5390.00	61.4 PK	74.0	-12.6	1.00 H	327	56.70	4.70
2	5390.00	47.7 AV	54.0	-6.3	1.00 H	327	43.00	4.70
3	#5470.00	64.8 PK	68.3	-3.5	1.01 H	280	60.20	4.60
4	*5550.00	106.7 PK			1.04 H	354	102.00	4.70
5	*5550.00	96.2 AV			1.04 H	354	91.50	4.70
6	#5725.00	56.2 PK	68.3	-12.1	1.01 H	350	51.30	4.90
7	11100.00	56.0 PK	74.0	-18.0	1.19 H	138	45.30	10.70
8	11100.00	43.2 AV	54.0	-10.8	1.19 H	138	32.50	10.70
9	#16650.00	59.6 PK	68.3	-8.7	1.15 H	130	42.10	17.50

ANTENNA POLARITY & TEST DISTANCE: VERTICAL AT 3 M

NO.	FREQ. (MHz)	EMISSION LEVEL (dBuV/m)	LIMIT (dBuV/m)	MARGIN (dB)	ANTENNA HEIGHT (m)	TABLE ANGLE (Degree)	RAW VALUE (dBuV)	CORRECTION FACTOR (dB/m)
1	5390.00	62.2 PK	74.0	-11.8	1.30 V	194	57.50	4.70
2	5390.00	48.4 AV	54.0	-5.6	1.30 V	194	43.70	4.70
3	#5470.00	67.9 PK	68.3	-0.4	1.00 V	247	63.30	4.60
4	*5550.00	108.7 PK			1.00 V	275	104.00	4.70
5	*5550.00	99.1 AV			1.00 V	275	94.40	4.70
6	#5725.00	64.7 PK	68.3	-3.6	1.00 V	148	59.80	4.90
7	11100.00	56.4 PK	74.0	-17.6	1.23 V	114	45.70	10.70
8	11100.00	43.3 AV	54.0	-10.7	1.23 V	114	32.60	10.70
9	#16650.00	60.6 PK	68.3	-7.7	1.00 V	125	43.10	17.50

REMARKS:

1. Emission Level(dBuV/m) = Raw Value(dBuV) + Correction Factor(dB/m)
2. Correction Factor(dB/m) = Antenna Factor(dB/m) + Cable Factor(dB) – Pre-Amplifier Factor(dB)
3. The other emission levels were very low against the limit.
4. Margin value = Emission Level – Limit value
5. " * " : Fundamental frequency.
6. " # " : The radiated frequency is out of the restricted band.



A D T

CHANNEL	TX Channel 134	DETECTOR FUNCTION	Peak (PK)
FREQUENCY RANGE	1GHz ~ 40GHz		Average (AV)

ANTENNA POLARITY & TEST DISTANCE: HORIZONTAL AT 3 M

NO.	FREQ. (MHz)	EMISSION LEVEL (dBuV/m)	LIMIT (dBuV/m)	MARGIN (dB)	ANTENNA HEIGHT (m)	TABLE ANGLE (Degree)	RAW VALUE (dBuV)	CORRECTION FACTOR (dB/m)
1	*5670.00	104.7 PK			1.00 H	284	99.80	4.90
2	*5670.00	94.4 AV			1.00 H	284	89.50	4.90
3	#5750.00	61.7 PK	68.3	-6.6	1.19 H	2	56.80	4.90
4	#5830.00	55.8 PK	68.3	-12.5	1.18 H	360	50.70	5.10
5	11340.00	55.7 PK	74.0	-18.3	1.23 H	166	44.90	10.80
6	11340.00	42.8 AV	54.0	-11.2	1.23 H	166	32.00	10.80
7	#17010.00	59.9 PK	68.3	-8.4	1.08 H	126	41.50	18.40

ANTENNA POLARITY & TEST DISTANCE: VERTICAL AT 3 M

NO.	FREQ. (MHz)	EMISSION LEVEL (dBuV/m)	LIMIT (dBuV/m)	MARGIN (dB)	ANTENNA HEIGHT (m)	TABLE ANGLE (Degree)	RAW VALUE (dBuV)	CORRECTION FACTOR (dB/m)
1	*5670.00	109.0 PK			1.34 V	79	104.10	4.90
2	*5670.00	98.1 AV			1.34 V	79	93.20	4.90
3	#5750.00	67.9 PK	68.3	-0.4	1.32 V	80	63.00	4.90
4	#5830.00	63.8 PK	68.3	-4.5	1.00 V	216	58.70	5.10
5	11340.00	56.7 PK	74.0	-17.3	1.17 V	125	45.90	10.80
6	11340.00	43.4 AV	54.0	-10.6	1.17 V	125	32.60	10.80
7	#17010.00	60.4 PK	68.3	-7.9	1.05 V	132	42.00	18.40

REMARKS:

1. Emission Level(dBuV/m) = Raw Value(dBuV) + Correction Factor(dB/m)
2. Correction Factor(dB/m) = Antenna Factor(dB/m) + Cable Factor(dB) – Pre-Amplifier Factor(dB)
3. The other emission levels were very low against the limit.
4. Margin value = Emission Level – Limit value
5. " * " : Fundamental frequency.
6. " # " : The radiated frequency is out of the restricted band.



A D T

CHANNEL	TX Channel 142	DETECTOR FUNCTION	Peak (PK)
FREQUENCY RANGE	1GHz ~ 40GHz		Average (AV)

ANTENNA POLARITY & TEST DISTANCE: HORIZONTAL AT 3 M

NO.	FREQ. (MHz)	EMISSION LEVEL (dBuV/m)	LIMIT (dBuV/m)	MARGIN (dB)	ANTENNA HEIGHT (m)	TABLE ANGLE (Degree)	RAW VALUE (dBuV)	CORRECTION FACTOR (dB/m)
1	*5710.00	107.4 PK			1.01 H	279	102.50	4.90
2	*5710.00	97.6 AV			1.01 H	279	92.70	4.90
3	11420.00	55.2 PK	74.0	-18.8	1.17 H	160	44.60	10.60
4	11420.00	42.5 AV	54.0	-11.5	1.17 H	160	31.90	10.60
5	#17130.00	59.6 PK	68.3	-8.7	1.13 H	127	40.70	18.90

ANTENNA POLARITY & TEST DISTANCE: VERTICAL AT 3 M

NO.	FREQ. (MHz)	EMISSION LEVEL (dBuV/m)	LIMIT (dBuV/m)	MARGIN (dB)	ANTENNA HEIGHT (m)	TABLE ANGLE (Degree)	RAW VALUE (dBuV)	CORRECTION FACTOR (dB/m)
1	*5710.00	110.9 PK			1.11 V	269	106.00	4.90
2	*5710.00	101.2 AV			1.11 V	269	96.30	4.90
3	11420.00	56.9 PK	74.0	-17.1	1.14 V	140	46.30	10.60
4	11420.00	43.6 AV	54.0	-10.4	1.14 V	140	33.00	10.60
5	#17130.00	60.5 PK	68.3	-7.8	1.00 V	139	41.60	18.90

REMARKS:

1. Emission Level(dBuV/m) = Raw Value(dBuV) + Correction Factor(dB/m)
2. Correction Factor(dB/m) = Antenna Factor(dB/m) + Cable Factor(dB) – Pre-Amplifier Factor(dB)
3. The other emission levels were very low against the limit.
4. Margin value = Emission Level – Limit value
5. " * ": Fundamental frequency.
6. " # ": The radiated frequency is out of the restricted band.



A D T

802.11ac (VHT80)

CHANNEL	TX Channel 58	DETECTOR FUNCTION	Peak (PK)
FREQUENCY RANGE	1GHz ~ 40GHz		Average (AV)

ANTENNA POLARITY & TEST DISTANCE: HORIZONTAL AT 3 M

NO.	FREQ. (MHz)	EMISSION LEVEL (dBuV/m)	LIMIT (dBuV/m)	MARGIN (dB)	ANTENNA HEIGHT (m)	TABLE ANGLE (Degree)	RAW VALUE (dBuV)	CORRECTION FACTOR (dB/m)
1	*5290.00	103.1 PK			1.04 H	360	98.80	4.30
2	*5290.00	91.7 AV			1.04 H	360	87.40	4.30
3	5374.00	60.6 PK	74.0	-13.4	1.07 H	355	56.00	4.60
4	5374.00	48.8 AV	54.0	-5.2	1.07 H	355	44.20	4.60
5	#10580.00	55.4 PK	68.3	-12.9	1.19 H	157	44.80	10.60
6	15870.00	59.6 PK	74.0	-14.4	1.18 H	142	44.70	14.90
7	15870.00	46.9 AV	54.0	-7.1	1.18 H	142	32.00	14.90

ANTENNA POLARITY & TEST DISTANCE: VERTICAL AT 3 M

NO.	FREQ. (MHz)	EMISSION LEVEL (dBuV/m)	LIMIT (dBuV/m)	MARGIN (dB)	ANTENNA HEIGHT (m)	TABLE ANGLE (Degree)	RAW VALUE (dBuV)	CORRECTION FACTOR (dB/m)
1	*5290.00	105.5 PK			1.21 V	197	101.20	4.30
2	*5290.00	95.4 AV			1.21 V	197	91.10	4.30
3	5374.00	65.9 PK	74.0	-8.1	1.19 V	193	61.30	4.60
4	5374.00	53.6 AV	54.0	-0.4	1.19 V	193	49.00	4.60
5	#10580.00	57.4 PK	68.3	-10.9	1.12 V	128	46.80	10.60
6	15870.00	60.6 PK	74.0	-13.4	1.02 V	134	45.70	14.90
7	15870.00	44.1 AV	54.0	-9.9	1.02 V	134	29.20	14.90

REMARKS:

1. Emission Level(dBuV/m) = Raw Value(dBuV) + Correction Factor(dB/m)
2. Correction Factor(dB/m) = Antenna Factor(dB/m) + Cable Factor(dB) – Pre-Amplifier Factor(dB)
3. The other emission levels were very low against the limit.
4. Margin value = Emission Level – Limit value
5. " * ": Fundamental frequency.
6. " # ": The radiated frequency is out of the restricted band.



A D T

CHANNEL	TX Channel 106	DETECTOR FUNCTION	Peak (PK)
FREQUENCY RANGE	1GHz ~ 40GHz		Average (AV)

ANTENNA POLARITY & TEST DISTANCE: HORIZONTAL AT 3 M

NO.	FREQ. (MHz)	EMISSION LEVEL (dBuV/m)	LIMIT (dBuV/m)	MARGIN (dB)	ANTENNA HEIGHT (m)	TABLE ANGLE (Degree)	RAW VALUE (dBuV)	CORRECTION FACTOR (dB/m)
1	#5470.00	65.8 PK	68.3	-2.5	1.25 H	192	61.20	4.60
2	*5530.00	102.2 PK			1.00 H	346	97.60	4.60
3	*5530.00	90.2 AV			1.00 H	346	85.60	4.60
4	#5725.00	53.4 PK	68.3	-14.9	1.00 H	2	48.50	4.90
5	11060.00	55.0 PK	74.0	-19.0	1.14 H	152	44.30	10.70
6	11060.00	42.5 AV	54.0	-11.5	1.14 H	152	31.80	10.70
7	#16590.00	59.5 PK	68.3	-8.8	1.18 H	128	42.40	17.10

ANTENNA POLARITY & TEST DISTANCE: VERTICAL AT 3 M

NO.	FREQ. (MHz)	EMISSION LEVEL (dBuV/m)	LIMIT (dBuV/m)	MARGIN (dB)	ANTENNA HEIGHT (m)	TABLE ANGLE (Degree)	RAW VALUE (dBuV)	CORRECTION FACTOR (dB/m)
1	#5470.00	68.1 PK	68.3	-0.2	1.26 V	89	63.50	4.60
2	*5530.00	104.0 PK			1.26 V	98	99.40	4.60
3	*5530.00	94.2 AV			1.26 V	98	89.60	4.60
4	#5725.00	61.5 PK	68.3	-6.8	1.21 V	100	56.60	4.90
5	11060.00	57.1 PK	74.0	-16.9	1.15 V	132	46.40	10.70
6	11060.00	43.6 AV	54.0	-10.4	1.15 V	132	32.90	10.70
7	#16590.00	60.7 PK	68.3	-7.6	1.07 V	138	43.60	17.10

REMARKS:

1. Emission Level(dBuV/m) = Raw Value(dBuV) + Correction Factor(dB/m)
2. Correction Factor(dB/m) = Antenna Factor(dB/m) + Cable Factor(dB) – Pre-Amplifier Factor(dB)
3. The other emission levels were very low against the limit.
4. Margin value = Emission Level – Limit value
5. " * ": Fundamental frequency.
6. " # ": The radiated frequency is out of the restricted band.



A D T

CHANNEL	TX Channel 138	DETECTOR FUNCTION	Peak (PK)
FREQUENCY RANGE	1GHz ~ 40GHz		Average (AV)

ANTENNA POLARITY & TEST DISTANCE: HORIZONTAL AT 3 M

NO.	FREQ. (MHz)	EMISSION LEVEL (dBuV/m)	LIMIT (dBuV/m)	MARGIN (dB)	ANTENNA HEIGHT (m)	TABLE ANGLE (Degree)	RAW VALUE (dBuV)	CORRECTION FACTOR (dB/m)
1	5060.00	54.2 PK	74.0	-19.8	1.15 H	356	50.20	4.00
2	5060.00	48.4 AV	54.0	-5.6	1.15 H	356	44.40	4.00
3	*5690.00	105.2 PK			1.01 H	352	100.20	5.00
4	*5690.00	95.0 AV			1.01 H	352	90.00	5.00
5	#5850.00	62.3 PK	68.3	-6.0	1.00 H	350	57.20	5.10
6	11380.00	54.4 PK	74.0	-19.6	1.15 H	142	43.70	10.70
7	11380.00	42.1 AV	54.0	-11.9	1.15 H	142	31.40	10.70
8	#17070.00	59.3 PK	68.3	-9.0	1.21 H	141	40.80	18.50

ANTENNA POLARITY & TEST DISTANCE: VERTICAL AT 3 M

NO.	FREQ. (MHz)	EMISSION LEVEL (dBuV/m)	LIMIT (dBuV/m)	MARGIN (dB)	ANTENNA HEIGHT (m)	TABLE ANGLE (Degree)	RAW VALUE (dBuV)	CORRECTION FACTOR (dB/m)
1	5060.00	58.2 PK	74.0	-15.8	1.00 V	172	54.20	4.00
2	5060.00	48.8 AV	54.0	-5.2	1.00 V	172	44.80	4.00
3	*5690.00	110.8 PK			1.10 V	150	105.80	5.00
4	*5690.00	101.5 AV			1.10 V	150	96.50	5.00
5	#5850.00	67.1 PK	68.3	-1.2	1.00 V	268	62.00	5.10
6	11380.00	56.9 PK	74.0	-17.1	1.11 V	132	46.20	10.70
7	11380.00	43.4 AV	54.0	-10.6	1.11 V	132	32.70	10.70
8	#17070.00	60.9 PK	68.3	-7.4	1.13 V	138	42.40	18.50

REMARKS:

1. Emission Level(dBuV/m) = Raw Value(dBuV) + Correction Factor(dB/m)
2. Correction Factor(dB/m) = Antenna Factor(dB/m) + Cable Factor(dB) – Pre-Amplifier Factor(dB)
3. The other emission levels were very low against the limit.
4. Margin value = Emission Level – Limit value
5. " * ": Fundamental frequency.
6. " # ": The radiated frequency is out of the restricted band.



A D T

STBC_MODE

ABOVE 1GHz DATA

802.11ac (VHT20)

CHANNEL	TX Channel 52	DETECTOR FUNCTION	Peak (PK)
FREQUENCY RANGE	1GHz ~ 40GHz		Average (AV)

ANTENNA POLARITY & TEST DISTANCE: HORIZONTAL AT 3 M

NO.	FREQ. (MHz)	EMISSION LEVEL (dBuV/m)	LIMIT (dBuV/m)	MARGIN (dB)	ANTENNA HEIGHT (m)	TABLE ANGLE (Degree)	RAW VALUE (dBuV)	CORRECTION FACTOR (dB/m)
1	*5260.00	106.8 PK			1.00 H	360	102.40	4.40
2	*5260.00	95.1 AV			1.00 H	360	90.70	4.40
3	5420.00	59.1 PK	74.0	-14.9	1.18 H	19	54.50	4.60
4	5420.00	46.7 AV	54.0	-7.3	1.18 H	19	42.10	4.60
5	#10520.00	55.8 PK	68.3	-12.5	1.20 H	159	45.40	10.40
6	15780.00	60.6 PK	74.0	-13.4	1.18 H	143	45.90	14.70
7	15780.00	47.8 AV	54.0	-6.2	1.18 H	143	33.10	14.70

ANTENNA POLARITY & TEST DISTANCE: VERTICAL AT 3 M

NO.	FREQ. (MHz)	EMISSION LEVEL (dBuV/m)	LIMIT (dBuV/m)	MARGIN (dB)	ANTENNA HEIGHT (m)	TABLE ANGLE (Degree)	RAW VALUE (dBuV)	CORRECTION FACTOR (dB/m)
1	*5260.00	106.0 PK			1.12 V	202	101.60	4.40
2	*5260.00	95.3 AV			1.12 V	202	90.90	4.40
3	5420.00	65.2 PK	74.0	-8.8	1.07 V	204	60.60	4.60
4	5420.00	53.1 AV	54.0	-0.9	1.07 V	204	48.50	4.60
5	#10520.00	55.2 PK	68.3	-13.1	1.43 V	83	44.80	10.40
6	15780.00	58.8 PK	74.0	-15.2	1.14 V	128	44.10	14.70
7	15780.00	46.4 AV	54.0	-7.6	1.14 V	128	31.70	14.70

REMARKS:

1. Emission Level(dBuV/m) = Raw Value(dBuV) + Correction Factor(dB/m)
2. Correction Factor(dB/m) = Antenna Factor(dB/m) + Cable Factor(dB) – Pre-Amplifier Factor(dB)
3. The other emission levels were very low against the limit.
4. Margin value = Emission Level – Limit value
5. " * ": Fundamental frequency.
6. " # ": The radiated frequency is out of the restricted band.



A D T

CHANNEL	TX Channel 60	DETECTOR FUNCTION	Peak (PK)
FREQUENCY RANGE	1GHz ~ 40GHz		Average (AV)

ANTENNA POLARITY & TEST DISTANCE: HORIZONTAL AT 3 M

NO.	FREQ. (MHz)	EMISSION LEVEL (dBuV/m)	LIMIT (dBuV/m)	MARGIN (dB)	ANTENNA HEIGHT (m)	TABLE ANGLE (Degree)	RAW VALUE (dBuV)	CORRECTION FACTOR (dB/m)
1	5080.00	59.3 PK	74.0	-14.7	1.04 H	168	55.20	4.10
2	5080.00	46.8 AV	54.0	-7.2	1.04 H	168	42.70	4.10
3	*5300.00	106.4 PK			1.00 H	192	102.00	4.40
4	*5300.00	95.2 AV			1.00 H	192	90.80	4.40
5	5381.00	59.2 PK	74.0	-14.8	1.23 H	10	54.50	4.70
6	5381.00	47.0 AV	54.0	-7.0	1.23 H	10	42.30	4.70
7	10600.00	55.9 PK	74.0	-18.1	1.21 H	160	45.30	10.60
8	10600.00	43.5 AV	54.0	-10.5	1.21 H	160	32.90	10.60
9	15900.00	60.9 PK	74.0	-13.1	1.12 H	157	45.80	15.10
10	15900.00	48.0 AV	54.0	-6.0	1.12 H	157	32.90	15.10

ANTENNA POLARITY & TEST DISTANCE: VERTICAL AT 3 M

NO.	FREQ. (MHz)	EMISSION LEVEL (dBuV/m)	LIMIT (dBuV/m)	MARGIN (dB)	ANTENNA HEIGHT (m)	TABLE ANGLE (Degree)	RAW VALUE (dBuV)	CORRECTION FACTOR (dB/m)
1	5080.00	59.3 PK	74.0	-14.7	1.05 V	194	55.20	4.10
2	5080.00	50.0 AV	54.0	-4.0	1.05 V	194	45.90	4.10
3	*5300.00	106.4 PK			1.21 V	182	102.00	4.40
4	*5300.00	95.8 AV			1.21 V	182	91.40	4.40
5	5381.00	64.4 PK	74.0	-9.6	1.08 V	203	59.70	4.70
6	5381.00	53.7 AV	54.0	-0.3	1.08 V	203	49.00	4.70
7	10600.00	55.2 PK	74.0	-18.8	1.38 V	81	44.60	10.60
8	10600.00	42.6 AV	54.0	-11.4	1.38 V	81	32.00	10.60
9	15900.00	58.4 PK	74.0	-15.6	1.13 V	121	43.30	15.10
10	15900.00	46.3 AV	54.0	-7.7	1.13 V	121	31.20	15.10

REMARKS:

1. Emission Level(dBuV/m) = Raw Value(dBuV) + Correction Factor(dB/m)
2. Correction Factor(dB/m) = Antenna Factor(dB/m) + Cable Factor(dB) – Pre-Amplifier Factor(dB)
3. The other emission levels were very low against the limit.
4. Margin value = Emission Level – Limit value
5. " * ": Fundamental frequency.



A D T

CHANNEL	TX Channel 64	DETECTOR FUNCTION	Peak (PK)
FREQUENCY RANGE	1GHz ~ 40GHz		Average (AV)

ANTENNA POLARITY & TEST DISTANCE: HORIZONTAL AT 3 M

NO.	FREQ. (MHz)	EMISSION LEVEL (dBuV/m)	LIMIT (dBuV/m)	MARGIN (dB)	ANTENNA HEIGHT (m)	TABLE ANGLE (Degree)	RAW VALUE (dBuV)	CORRECTION FACTOR (dB/m)
1	*5320.00	105.5 PK			1.08 H	184	101.10	4.40
2	*5320.00	94.2 AV			1.08 H	184	89.80	4.40
3	5400.00	58.9 PK	74.0	-15.1	1.06 H	179	54.20	4.70
4	5400.00	46.6 AV	54.0	-7.4	1.06 H	179	41.90	4.70
5	10640.00	55.8 PK	74.0	-18.2	1.18 H	162	45.20	10.60
6	10640.00	43.3 AV	54.0	-10.7	1.18 H	162	32.70	10.60
7	15960.00	61.4 PK	74.0	-12.6	1.17 H	166	46.50	14.90
8	15960.00	48.3 AV	54.0	-5.7	1.17 H	166	33.40	14.90

ANTENNA POLARITY & TEST DISTANCE: VERTICAL AT 3 M

NO.	FREQ. (MHz)	EMISSION LEVEL (dBuV/m)	LIMIT (dBuV/m)	MARGIN (dB)	ANTENNA HEIGHT (m)	TABLE ANGLE (Degree)	RAW VALUE (dBuV)	CORRECTION FACTOR (dB/m)
1	*5320.00	106.1 PK			1.00 V	202	101.70	4.40
2	*5320.00	95.4 AV			1.00 V	202	91.00	4.40
3	5400.00	64.6 PK	74.0	-9.4	1.05 V	204	59.90	4.70
4	5400.00	53.8 AV	54.0	-0.2	1.05 V	204	49.10	4.70
5	10640.00	54.7 PK	74.0	-19.3	1.34 V	75	44.10	10.60
6	10640.00	42.3 AV	54.0	-11.7	1.34 V	75	31.70	10.60
7	15960.00	57.9 PK	74.0	-16.1	1.18 V	130	43.00	14.90
8	15960.00	45.8 AV	54.0	-8.2	1.18 V	130	30.90	14.90

REMARKS:

1. Emission Level(dBuV/m) = Raw Value(dBuV) + Correction Factor(dB/m)
2. Correction Factor(dB/m) = Antenna Factor(dB/m) + Cable Factor(dB) – Pre-Amplifier Factor(dB)
3. The other emission levels were very low against the limit.
4. Margin value = Emission Level – Limit value
5. " * ": Fundamental frequency.



A D T

CHANNEL	TX Channel 100	DETECTOR FUNCTION	Peak (PK)
FREQUENCY RANGE	1GHz ~ 40GHz		Average (AV)

ANTENNA POLARITY & TEST DISTANCE: HORIZONTAL AT 3 M

NO.	FREQ. (MHz)	EMISSION LEVEL (dBuV/m)	LIMIT (dBuV/m)	MARGIN (dB)	ANTENNA HEIGHT (m)	TABLE ANGLE (Degree)	RAW VALUE (dBuV)	CORRECTION FACTOR (dB/m)
1	#5340.00	54.8 PK	68.3	-13.5	1.26 H	273	50.40	4.40
2	5420.00	63.0 PK	74.0	-11.0	1.17 H	196	58.40	4.60
3	5420.00	51.7 AV	54.0	-2.3	1.17 H	196	47.10	4.60
4	*5500.00	107.1 PK			1.04 H	196	102.50	4.60
5	*5500.00	97.4 AV			1.04 H	196	92.80	4.60
6	11000.00	55.5 PK	74.0	-18.5	1.20 H	147	44.70	10.80
7	11000.00	42.9 AV	54.0	-11.1	1.20 H	147	32.10	10.80
8	#16500.00	61.4 PK	68.3	-6.9	1.12 H	158	44.40	17.00

ANTENNA POLARITY & TEST DISTANCE: VERTICAL AT 3 M

NO.	FREQ. (MHz)	EMISSION LEVEL (dBuV/m)	LIMIT (dBuV/m)	MARGIN (dB)	ANTENNA HEIGHT (m)	TABLE ANGLE (Degree)	RAW VALUE (dBuV)	CORRECTION FACTOR (dB/m)
1	#5340.00	61.1 PK	68.3	-7.2	1.00 V	136	56.70	4.40
2	5420.00	64.0 PK	74.0	-10.0	1.08 V	202	59.40	4.60
3	5420.00	53.0 AV	54.0	-1.0	1.08 V	202	48.40	4.60
4	*5500.00	110.0 PK			1.05 V	204	105.40	4.60
5	*5500.00	99.4 AV			1.05 V	204	94.80	4.60
6	11000.00	55.2 PK	74.0	-18.8	1.33 V	83	44.40	10.80
7	11000.00	42.8 AV	54.0	-11.2	1.33 V	83	32.00	10.80
8	#16500.00	57.9 PK	68.3	-10.4	1.17 V	145	40.90	17.00

REMARKS:

1. Emission Level(dBuV/m) = Raw Value(dBuV) + Correction Factor(dB/m)
2. Correction Factor(dB/m) = Antenna Factor(dB/m) + Cable Factor(dB) – Pre-Amplifier Factor(dB)
3. The other emission levels were very low against the limit.
4. Margin value = Emission Level – Limit value
5. " * ": Fundamental frequency.
6. " # ": The radiated frequency is out of the restricted band.



A D T

CHANNEL	TX Channel 116	DETECTOR FUNCTION	Peak (PK)
FREQUENCY RANGE	1GHz ~ 40GHz		Average (AV)

ANTENNA POLARITY & TEST DISTANCE: HORIZONTAL AT 3 M

NO.	FREQ. (MHz)	EMISSION LEVEL (dBuV/m)	LIMIT (dBuV/m)	MARGIN (dB)	ANTENNA HEIGHT (m)	TABLE ANGLE (Degree)	RAW VALUE (dBuV)	CORRECTION FACTOR (dB/m)
1	5420.00	52.5 PK	74.0	-21.5	1.03 H	83	47.90	4.60
2	5420.00	41.0 AV	54.0	-13.0	1.03 H	83	36.40	4.60
3	*5580.00	110.5 PK			1.02 H	194	105.60	4.90
4	*5580.00	100.1 AV			1.02 H	194	95.20	4.90
5	#5740.00	57.5 PK	68.3	-10.8	1.23 H	273	52.60	4.90
6	11160.00	56.0 PK	74.0	-18.0	1.16 H	143	45.30	10.70
7	11160.00	43.3 AV	54.0	-10.7	1.16 H	143	32.60	10.70
8	#16740.00	61.2 PK	68.3	-7.1	1.06 H	146	43.30	17.90

ANTENNA POLARITY & TEST DISTANCE: VERTICAL AT 3 M

NO.	FREQ. (MHz)	EMISSION LEVEL (dBuV/m)	LIMIT (dBuV/m)	MARGIN (dB)	ANTENNA HEIGHT (m)	TABLE ANGLE (Degree)	RAW VALUE (dBuV)	CORRECTION FACTOR (dB/m)
1	5420.00	64.1 PK	74.0	-9.9	1.00 V	136	59.50	4.60
2	5420.00	51.7 AV	54.0	-2.3	1.00 V	136	47.10	4.60
3	*5580.00	112.5 PK			1.04 V	205	107.60	4.90
4	*5580.00	102.0 AV			1.04 V	205	97.10	4.90
5	#5740.00	67.9 PK	68.3	-0.4	1.00 V	213	63.00	4.90
6	11160.00	55.5 PK	74.0	-18.5	1.36 V	95	44.80	10.70
7	11160.00	42.9 AV	54.0	-11.1	1.36 V	95	32.20	10.70
8	#16740.00	58.3 PK	68.3	-10.0	1.14 V	130	40.40	17.90

REMARKS:

1. Emission Level(dBuV/m) = Raw Value(dBuV) + Correction Factor(dB/m)
2. Correction Factor(dB/m) = Antenna Factor(dB/m) + Cable Factor(dB) – Pre-Amplifier Factor(dB)
3. The other emission levels were very low against the limit.
4. Margin value = Emission Level – Limit value
5. " * ": Fundamental frequency.
6. " # ": The radiated frequency is out of the restricted band.



A D T

CHANNEL	TX Channel 132	DETECTOR FUNCTION	Peak (PK)
FREQUENCY RANGE	1GHz ~ 40GHz		Average (AV)

ANTENNA POLARITY & TEST DISTANCE: HORIZONTAL AT 3 M

NO.	FREQ. (MHz)	EMISSION LEVEL (dBuV/m)	LIMIT (dBuV/m)	MARGIN (dB)	ANTENNA HEIGHT (m)	TABLE ANGLE (Degree)	RAW VALUE (dBuV)	CORRECTION FACTOR (dB/m)
1	*5660.00	109.4 PK			1.08 H	200	104.50	4.90
2	*5660.00	97.3 AV			1.08 H	200	92.40	4.90
3	#5740.00	58.8 PK	68.3	-9.5	1.02 H	77	53.90	4.90
4	11320.00	56.3 PK	74.0	-17.7	1.16 H	154	45.50	10.80
5	11320.00	43.4 AV	54.0	-10.6	1.16 H	154	32.60	10.80
6	#16980.00	61.6 PK	68.3	-6.7	1.03 H	132	43.20	18.40

ANTENNA POLARITY & TEST DISTANCE: VERTICAL AT 3 M

NO.	FREQ. (MHz)	EMISSION LEVEL (dBuV/m)	LIMIT (dBuV/m)	MARGIN (dB)	ANTENNA HEIGHT (m)	TABLE ANGLE (Degree)	RAW VALUE (dBuV)	CORRECTION FACTOR (dB/m)
1	*5660.00	110.8 PK			1.22 V	100	105.90	4.90
2	*5660.00	99.2 AV			1.22 V	100	94.30	4.90
3	#5740.00	67.9 PK	68.3	-0.4	1.00 V	208	63.00	4.90
4	11320.00	54.9 PK	74.0	-19.1	1.42 V	99	44.10	10.80
5	11320.00	42.5 AV	54.0	-11.5	1.42 V	99	31.70	10.80
6	#16980.00	58.4 PK	68.3	-9.9	1.16 V	146	40.00	18.40

REMARKS:

1. Emission Level(dBuV/m) = Raw Value(dBuV) + Correction Factor(dB/m)
2. Correction Factor(dB/m) = Antenna Factor(dB/m) + Cable Factor(dB) – Pre-Amplifier Factor(dB)
3. The other emission levels were very low against the limit.
4. Margin value = Emission Level – Limit value
5. " * ": Fundamental frequency.
6. " # ": The radiated frequency is out of the restricted band.



A D T

CHANNEL	TX Channel 140	DETECTOR FUNCTION	Peak (PK)
FREQUENCY RANGE	1GHz ~ 40GHz		Average (AV)

ANTENNA POLARITY & TEST DISTANCE: HORIZONTAL AT 3 M

NO.	FREQ. (MHz)	EMISSION LEVEL (dBuV/m)	LIMIT (dBuV/m)	MARGIN (dB)	ANTENNA HEIGHT (m)	TABLE ANGLE (Degree)	RAW VALUE (dBuV)	CORRECTION FACTOR (dB/m)
1	*5700.00	108.9 PK			1.00 H	4	104.00	4.90
2	*5700.00	97.9 AV			1.00 H	4	93.00	4.90
3	#5780.00	61.3 PK	68.3	-7.0	1.06 H	270	56.40	4.90
4	11400.00	56.1 PK	74.0	-17.9	1.19 H	151	45.40	10.70
5	11400.00	43.1 AV	54.0	-10.9	1.19 H	151	32.40	10.70
6	#17100.00	61.8 PK	68.3	-6.5	1.00 H	133	43.20	18.60

ANTENNA POLARITY & TEST DISTANCE: VERTICAL AT 3 M

NO.	FREQ. (MHz)	EMISSION LEVEL (dBuV/m)	LIMIT (dBuV/m)	MARGIN (dB)	ANTENNA HEIGHT (m)	TABLE ANGLE (Degree)	RAW VALUE (dBuV)	CORRECTION FACTOR (dB/m)
1	*5700.00	110.6 PK			1.00 V	206	105.70	4.90
2	*5700.00	100.0 AV			1.00 V	206	95.10	4.90
3	#5780.00	68.1 PK	68.3	-0.2	1.00 V	213	63.20	4.90
4	11400.00	54.5 PK	74.0	-19.5	1.36 V	91	43.80	10.70
5	11400.00	42.0 AV	54.0	-12.0	1.36 V	91	31.30	10.70
6	#17100.00	58.4 PK	68.3	-9.9	1.19 V	136	39.80	18.60

REMARKS:

1. Emission Level(dBuV/m) = Raw Value(dBuV) + Correction Factor(dB/m)
2. Correction Factor(dB/m) = Antenna Factor(dB/m) + Cable Factor(dB) – Pre-Amplifier Factor(dB)
3. The other emission levels were very low against the limit.
4. Margin value = Emission Level – Limit value
5. " * ": Fundamental frequency.
6. " # ": The radiated frequency is out of the restricted band.



A D T

CHANNEL	TX Channel 144	DETECTOR FUNCTION	Peak (PK)
FREQUENCY RANGE	1GHz ~ 40GHz		Average (AV)

ANTENNA POLARITY & TEST DISTANCE: HORIZONTAL AT 3 M

NO.	FREQ. (MHz)	EMISSION LEVEL (dBuV/m)	LIMIT (dBuV/m)	MARGIN (dB)	ANTENNA HEIGHT (m)	TABLE ANGLE (Degree)	RAW VALUE (dBuV)	CORRECTION FACTOR (dB/m)
1	*5720.00	110.2 PK			1.00 H	10	105.30	4.90
2	*5720.00	101.4 AV			1.00 H	10	96.50	4.90
3	#5882.00	59.7 PK	68.3	-8.6	1.12 H	90	54.50	5.20
4	11440.00	55.9 PK	74.0	-18.1	1.23 H	160	45.30	10.60
5	11440.00	43.0 AV	54.0	-11.0	1.23 H	160	32.40	10.60
6	#17160.00	61.5 PK	68.3	-6.8	1.00 H	142	42.40	19.10

ANTENNA POLARITY & TEST DISTANCE: VERTICAL AT 3 M

NO.	FREQ. (MHz)	EMISSION LEVEL (dBuV/m)	LIMIT (dBuV/m)	MARGIN (dB)	ANTENNA HEIGHT (m)	TABLE ANGLE (Degree)	RAW VALUE (dBuV)	CORRECTION FACTOR (dB/m)
1	*5720.00	112.8 PK			1.06 V	165	107.90	4.90
2	*5720.00	103.2 AV			1.06 V	165	98.30	4.90
3	#5882.00	68.1 PK	68.3	-0.2	1.13 V	159	62.90	5.20
4	11440.00	54.9 PK	74.0	-19.1	1.30 V	84	44.30	10.60
5	11440.00	42.5 AV	54.0	-11.5	1.30 V	84	31.90	10.60
6	#17160.00	58.2 PK	68.3	-10.1	1.13 V	123	39.10	19.10

REMARKS:

1. Emission Level(dBuV/m) = Raw Value(dBuV) + Correction Factor(dB/m)
2. Correction Factor(dB/m) = Antenna Factor(dB/m) + Cable Factor(dB) – Pre-Amplifier Factor(dB)
3. The other emission levels were very low against the limit.
4. Margin value = Emission Level – Limit value
5. " * ": Fundamental frequency.
6. " # ": The radiated frequency is out of the restricted band.



A D T

802.11ac (VHT40)

CHANNEL	TX Channel 54	DETECTOR FUNCTION	Peak (PK)
FREQUENCY RANGE	1GHz ~ 40GHz		Average (AV)

ANTENNA POLARITY & TEST DISTANCE: HORIZONTAL AT 3 M

NO.	FREQ. (MHz)	EMISSION LEVEL (dBuV/m)	LIMIT (dBuV/m)	MARGIN (dB)	ANTENNA HEIGHT (m)	TABLE ANGLE (Degree)	RAW VALUE (dBuV)	CORRECTION FACTOR (dB/m)
1	*5270.00	105.4 PK			1.10 H	342	101.10	4.30
2	*5270.00	94.6 AV			1.10 H	342	90.30	4.30
3	5360.00	63.3 PK	74.0	-10.7	1.00 H	360	58.80	4.50
4	5360.00	52.7 AV	54.0	-1.3	1.00 H	360	48.20	4.50
5	#10540.00	55.9 PK	68.3	-12.4	1.23 H	158	45.50	10.40
6	15810.00	61.7 PK	74.0	-12.3	1.01 H	152	46.90	14.80
7	15810.00	48.6 AV	54.0	-5.4	1.01 H	152	33.80	14.80

ANTENNA POLARITY & TEST DISTANCE: VERTICAL AT 3 M

NO.	FREQ. (MHz)	EMISSION LEVEL (dBuV/m)	LIMIT (dBuV/m)	MARGIN (dB)	ANTENNA HEIGHT (m)	TABLE ANGLE (Degree)	RAW VALUE (dBuV)	CORRECTION FACTOR (dB/m)
1	*5270.00	107.8 PK			1.45 V	279	103.50	4.30
2	*5270.00	96.7 AV			1.45 V	279	92.40	4.30
3	5360.00	63.7 PK	74.0	-10.3	1.41 V	265	59.20	4.50
4	5360.00	53.1 AV	54.0	-0.9	1.41 V	265	48.60	4.50
5	#10540.00	54.4 PK	68.3	-13.9	1.29 V	93	44.00	10.40
6	15810.00	58.2 PK	74.0	-15.8	1.12 V	123	43.40	14.80
7	15810.00	46.0 AV	54.0	-8.0	1.12 V	123	31.20	14.80

REMARKS:

1. Emission Level(dBuV/m) = Raw Value(dBuV) + Correction Factor(dB/m)
2. Correction Factor(dB/m) = Antenna Factor(dB/m) + Cable Factor(dB) – Pre-Amplifier Factor(dB)
3. The other emission levels were very low against the limit.
4. Margin value = Emission Level – Limit value
5. " * ": Fundamental frequency.
6. " # ": The radiated frequency is out of the restricted band.



A D T

CHANNEL	TX Channel 62	DETECTOR FUNCTION	Peak (PK)
FREQUENCY RANGE	1GHz ~ 40GHz		Average (AV)

ANTENNA POLARITY & TEST DISTANCE: HORIZONTAL AT 3 M

NO.	FREQ. (MHz)	EMISSION LEVEL (dBuV/m)	LIMIT (dBuV/m)	MARGIN (dB)	ANTENNA HEIGHT (m)	TABLE ANGLE (Degree)	RAW VALUE (dBuV)	CORRECTION FACTOR (dB/m)
1	*5310.00	104.1 PK			1.06 H	338	99.70	4.40
2	*5310.00	92.7 AV			1.06 H	338	88.30	4.40
3	5386.00	64.4 PK	74.0	-9.6	1.10 H	13	59.70	4.70
4	5386.00	49.1 AV	54.0	-4.9	1.10 H	13	44.40	4.70
5	5460.00	59.6 PK	74.0	-14.4	1.21 H	19	55.00	4.60
6	5460.00	46.9 AV	54.0	-7.1	1.21 H	19	42.30	4.60
7	10620.00	56.2 PK	74.0	-17.8	1.20 H	144	45.60	10.60
8	10620.00	43.0 AV	54.0	-11.0	1.20 H	144	32.40	10.60
9	15930.00	61.4 PK	74.0	-12.6	1.04 H	143	46.50	14.90
10	15930.00	48.5 AV	54.0	-5.5	1.04 H	143	33.60	14.90

ANTENNA POLARITY & TEST DISTANCE: VERTICAL AT 3 M

NO.	FREQ. (MHz)	EMISSION LEVEL (dBuV/m)	LIMIT (dBuV/m)	MARGIN (dB)	ANTENNA HEIGHT (m)	TABLE ANGLE (Degree)	RAW VALUE (dBuV)	CORRECTION FACTOR (dB/m)
1	*5310.00	106.1 PK			1.44 V	278	101.70	4.40
2	*5310.00	95.1 AV			1.44 V	278	90.70	4.40
3	5386.00	64.3 PK	74.0	-9.7	1.41 V	264	59.60	4.70
4	5386.00	53.7 AV	54.0	-0.3	1.41 V	264	49.00	4.70
5	5460.00	62.6 PK	74.0	-11.4	1.39 V	184	58.00	4.60
6	5460.00	51.6 AV	54.0	-2.4	1.39 V	184	47.00	4.60
7	10620.00	54.4 PK	74.0	-19.6	1.29 V	100	43.80	10.60
8	10620.00	42.3 AV	54.0	-11.7	1.29 V	100	31.70	10.60
9	15930.00	57.9 PK	74.0	-16.1	1.10 V	125	43.00	14.90
10	15930.00	45.9 AV	54.0	-8.1	1.10 V	125	31.00	14.90

REMARKS:

1. Emission Level(dBuV/m) = Raw Value(dBuV) + Correction Factor(dB/m)
2. Correction Factor(dB/m) = Antenna Factor(dB/m) + Cable Factor(dB) – Pre-Amplifier Factor(dB)
3. The other emission levels were very low against the limit.
4. Margin value = Emission Level – Limit value
5. " * ": Fundamental frequency.



A D T

CHANNEL	TX Channel 102	DETECTOR FUNCTION	Peak (PK)
FREQUENCY RANGE	1GHz ~ 40GHz		Average (AV)

ANTENNA POLARITY & TEST DISTANCE: HORIZONTAL AT 3 M

NO.	FREQ. (MHz)	EMISSION LEVEL (dBuV/m)	LIMIT (dBuV/m)	MARGIN (dB)	ANTENNA HEIGHT (m)	TABLE ANGLE (Degree)	RAW VALUE (dBuV)	CORRECTION FACTOR (dB/m)
1	5430.00	67.6 PK	74.0	-6.4	1.11 H	350	62.90	4.70
2	5430.00	50.4 AV	54.0	-3.6	1.11 H	350	45.70	4.70
3	#5470.00	61.4 PK	68.3	-6.9	1.00 H	105	56.80	4.60
4	*5510.00	106.2 PK			1.10 H	348	101.60	4.60
5	*5510.00	96.3 AV			1.10 H	348	91.70	4.60
6	11020.00	56.1 PK	74.0	-17.9	1.20 H	132	45.30	10.80
7	11020.00	42.7 AV	54.0	-11.3	1.20 H	132	31.90	10.80
8	#16530.00	61.8 PK	68.3	-6.5	1.02 H	147	44.70	17.10

ANTENNA POLARITY & TEST DISTANCE: VERTICAL AT 3 M

NO.	FREQ. (MHz)	EMISSION LEVEL (dBuV/m)	LIMIT (dBuV/m)	MARGIN (dB)	ANTENNA HEIGHT (m)	TABLE ANGLE (Degree)	RAW VALUE (dBuV)	CORRECTION FACTOR (dB/m)
1	5430.00	67.5 PK	74.0	-6.5	1.39 V	265	62.80	4.70
2	5430.00	53.4 AV	54.0	-0.6	1.39 V	265	48.70	4.70
3	#5470.00	68.1 PK	68.3	-0.2	1.02 V	174	63.50	4.60
4	*5510.00	109.7 PK			1.16 V	185	105.10	4.60
5	*5510.00	98.5 AV			1.16 V	185	93.90	4.60
6	11020.00	54.6 PK	74.0	-19.4	1.24 V	92	43.80	10.80
7	11020.00	42.4 AV	54.0	-11.6	1.24 V	92	31.60	10.80
8	#16530.00	57.5 PK	68.3	-10.8	1.05 V	131	40.40	17.10

REMARKS:

1. Emission Level(dBuV/m) = Raw Value(dBuV) + Correction Factor(dB/m)
2. Correction Factor(dB/m) = Antenna Factor(dB/m) + Cable Factor(dB) – Pre-Amplifier Factor(dB)
3. The other emission levels were very low against the limit.
4. Margin value = Emission Level – Limit value
5. " * ": Fundamental frequency.
6. " # ": The radiated frequency is out of the restricted band.



A D T

CHANNEL	TX Channel 110	DETECTOR FUNCTION	Peak (PK)
FREQUENCY RANGE	1GHz ~ 40GHz		Average (AV)

ANTENNA POLARITY & TEST DISTANCE: HORIZONTAL AT 3 M

NO.	FREQ. (MHz)	EMISSION LEVEL (dBuV/m)	LIMIT (dBuV/m)	MARGIN (dB)	ANTENNA HEIGHT (m)	TABLE ANGLE (Degree)	RAW VALUE (dBuV)	CORRECTION FACTOR (dB/m)
1	5457.00	61.5 PK	74.0	-12.5	1.04 H	331	56.90	4.60
2	5457.00	48.1 AV	54.0	-5.9	1.04 H	331	43.50	4.60
3	#5470.00	64.8 PK	68.3	-3.5	1.04 H	264	60.20	4.60
4	*5550.00	108.7 PK			1.01 H	352	104.00	4.70
5	*5550.00	97.2 AV			1.01 H	352	92.50	4.70
6	#5725.00	56.3 PK	68.3	-12.0	1.00 H	343	51.40	4.90
7	11100.00	56.7 PK	74.0	-17.3	1.17 H	146	46.00	10.70
8	11100.00	43.0 AV	54.0	-11.0	1.17 H	146	32.30	10.70
9	#16650.00	61.8 PK	68.3	-6.5	1.03 H	145	44.30	17.50

ANTENNA POLARITY & TEST DISTANCE: VERTICAL AT 3 M

NO.	FREQ. (MHz)	EMISSION LEVEL (dBuV/m)	LIMIT (dBuV/m)	MARGIN (dB)	ANTENNA HEIGHT (m)	TABLE ANGLE (Degree)	RAW VALUE (dBuV)	CORRECTION FACTOR (dB/m)
1	5457.00	64.6 PK	74.0	-9.4	1.02 V	153	60.00	4.60
2	5457.00	53.6 AV	54.0	-0.4	1.02 V	153	49.00	4.60
3	#5470.00	67.9 PK	68.3	-0.4	1.37 V	262	63.30	4.60
4	*5550.00	110.6 PK			1.35 V	264	105.90	4.70
5	*5550.00	99.9 AV			1.35 V	264	95.20	4.70
6	#5725.00	64.1 PK	68.3	-4.2	1.05 V	163	59.20	4.90
7	11100.00	54.0 PK	74.0	-20.0	1.25 V	92	43.30	10.70
8	11100.00	42.0 AV	54.0	-12.0	1.25 V	92	31.30	10.70
9	#16650.00	57.6 PK	68.3	-10.7	1.10 V	138	40.10	17.50

REMARKS:

1. Emission Level(dBuV/m) = Raw Value(dBuV) + Correction Factor(dB/m)
2. Correction Factor(dB/m) = Antenna Factor(dB/m) + Cable Factor(dB) – Pre-Amplifier Factor(dB)
3. The other emission levels were very low against the limit.
4. Margin value = Emission Level – Limit value
5. " * " : Fundamental frequency.
6. " # " : The radiated frequency is out of the restricted band.



A D T

CHANNEL	TX Channel 134	DETECTOR FUNCTION	Peak (PK)
FREQUENCY RANGE	1GHz ~ 40GHz		Average (AV)

ANTENNA POLARITY & TEST DISTANCE: HORIZONTAL AT 3 M

NO.	FREQ. (MHz)	EMISSION LEVEL (dBuV/m)	LIMIT (dBuV/m)	MARGIN (dB)	ANTENNA HEIGHT (m)	TABLE ANGLE (Degree)	RAW VALUE (dBuV)	CORRECTION FACTOR (dB/m)
1	*5670.00	105.6 PK			1.00 H	287	100.70	4.90
2	*5670.00	95.1 AV			1.00 H	287	90.20	4.90
3	#5750.00	62.0 PK	68.3	-6.3	1.14 H	8	57.10	4.90
4	11340.00	56.6 PK	74.0	-17.4	1.17 H	131	45.80	10.80
5	11340.00	42.8 AV	54.0	-11.2	1.17 H	131	32.00	10.80
6	#17010.00	62.4 PK	68.3	-5.9	1.02 H	154	44.00	18.40

ANTENNA POLARITY & TEST DISTANCE: VERTICAL AT 3 M

NO.	FREQ. (MHz)	EMISSION LEVEL (dBuV/m)	LIMIT (dBuV/m)	MARGIN (dB)	ANTENNA HEIGHT (m)	TABLE ANGLE (Degree)	RAW VALUE (dBuV)	CORRECTION FACTOR (dB/m)
1	*5670.00	109.8 PK			1.11 V	187	104.90	4.90
2	*5670.00	99.0 AV			1.11 V	187	94.10	4.90
3	#5750.00	67.9 PK	68.3	-0.4	1.10 V	200	63.00	4.90
4	11340.00	54.2 PK	74.0	-19.8	1.24 V	93	43.40	10.80
5	11340.00	42.1 AV	54.0	-11.9	1.24 V	93	31.30	10.80
6	#17010.00	58.0 PK	68.3	-10.3	1.15 V	139	39.60	18.40

REMARKS:

1. Emission Level(dBuV/m) = Raw Value(dBuV) + Correction Factor(dB/m)
2. Correction Factor(dB/m) = Antenna Factor(dB/m) + Cable Factor(dB) – Pre-Amplifier Factor(dB)
3. The other emission levels were very low against the limit.
4. Margin value = Emission Level – Limit value
5. " * ": Fundamental frequency.
6. " # ": The radiated frequency is out of the restricted band.



A D T

CHANNEL	TX Channel 142	DETECTOR FUNCTION	Peak (PK)
FREQUENCY RANGE	1GHz ~ 40GHz		Average (AV)

ANTENNA POLARITY & TEST DISTANCE: HORIZONTAL AT 3 M

NO.	FREQ. (MHz)	EMISSION LEVEL (dBuV/m)	LIMIT (dBuV/m)	MARGIN (dB)	ANTENNA HEIGHT (m)	TABLE ANGLE (Degree)	RAW VALUE (dBuV)	CORRECTION FACTOR (dB/m)
1	*5710.00	106.8 PK			1.02 H	266	101.90	4.90
2	*5710.00	97.3 AV			1.02 H	266	92.40	4.90
3	#5865.00	62.1 PK	68.3	-6.2	1.22 H	12	57.00	5.10
4	11420.00	56.4 PK	74.0	-17.6	1.12 H	132	45.80	10.60
5	11420.00	42.8 AV	54.0	-11.2	1.12 H	132	32.20	10.60
6	#17130.00	61.8 PK	68.3	-6.5	1.00 H	152	42.90	18.90

ANTENNA POLARITY & TEST DISTANCE: VERTICAL AT 3 M

NO.	FREQ. (MHz)	EMISSION LEVEL (dBuV/m)	LIMIT (dBuV/m)	MARGIN (dB)	ANTENNA HEIGHT (m)	TABLE ANGLE (Degree)	RAW VALUE (dBuV)	CORRECTION FACTOR (dB/m)
1	*5710.00	112.4 PK			1.05 V	164	107.50	4.90
2	*5710.00	101.0 AV			1.05 V	164	96.10	4.90
3	#5865.00	67.6 PK	68.3	-0.7	1.13 V	151	62.50	5.10
4	11420.00	54.5 PK	74.0	-19.5	1.25 V	96	43.90	10.60
5	11420.00	42.5 AV	54.0	-11.5	1.25 V	96	31.90	10.60
6	#17130.00	58.3 PK	68.3	-10.0	1.13 V	133	39.40	18.90

REMARKS:

1. Emission Level(dBuV/m) = Raw Value(dBuV) + Correction Factor(dB/m)
2. Correction Factor(dB/m) = Antenna Factor(dB/m) + Cable Factor(dB) – Pre-Amplifier Factor(dB)
3. The other emission levels were very low against the limit.
4. Margin value = Emission Level – Limit value
5. " * ": Fundamental frequency.
6. " # ": The radiated frequency is out of the restricted band.



A D T

802.11ac (VHT80)

CHANNEL	TX Channel 58	DETECTOR FUNCTION	Peak (PK)
FREQUENCY RANGE	1GHz ~ 40GHz		Average (AV)

ANTENNA POLARITY & TEST DISTANCE: HORIZONTAL AT 3 M

NO.	FREQ. (MHz)	EMISSION LEVEL (dBuV/m)	LIMIT (dBuV/m)	MARGIN (dB)	ANTENNA HEIGHT (m)	TABLE ANGLE (Degree)	RAW VALUE (dBuV)	CORRECTION FACTOR (dB/m)
1	5150.00	58.9 PK	74.0	-15.1	1.02 H	176	54.60	4.30
2	5150.00	46.6 AV	54.0	-7.4	1.02 H	176	42.30	4.30
3	*5290.00	105.4 PK			1.11 H	360	101.10	4.30
4	*5290.00	93.5 AV			1.11 H	360	89.20	4.30
5	5382.00	63.5 PK	74.0	-10.5	1.07 H	193	58.80	4.70
6	5382.00	50.4 AV	54.0	-3.6	1.07 H	193	45.70	4.70
7	#10580.00	57.0 PK	68.3	-11.3	1.21 H	152	46.40	10.60
8	15870.00	62.2 PK	74.0	-11.8	1.00 H	175	47.30	14.90
9	15870.00	49.2 AV	54.0	-4.8	1.00 H	175	34.30	14.90

ANTENNA POLARITY & TEST DISTANCE: VERTICAL AT 3 M

NO.	FREQ. (MHz)	EMISSION LEVEL (dBuV/m)	LIMIT (dBuV/m)	MARGIN (dB)	ANTENNA HEIGHT (m)	TABLE ANGLE (Degree)	RAW VALUE (dBuV)	CORRECTION FACTOR (dB/m)
1	5150.00	62.1 PK	74.0	-11.9	1.02 V	203	57.80	4.30
2	5150.00	45.4 AV	54.0	-8.6	1.02 V	203	41.10	4.30
3	*5290.00	106.3 PK			1.22 V	189	102.00	4.30
4	*5290.00	95.0 AV			1.22 V	189	90.70	4.30
5	5382.00	66.2 PK	74.0	-7.8	1.20 V	187	61.50	4.70
6	5382.00	53.6 AV	54.0	-0.4	1.20 V	187	48.90	4.70
7	#10580.00	54.2 PK	68.3	-14.1	1.25 V	78	43.60	10.60
8	15870.00	57.8 PK	74.0	-16.2	1.10 V	150	42.90	14.90
9	15870.00	45.3 AV	54.0	-8.7	1.10 V	150	30.40	14.90

REMARKS:

1. Emission Level(dBuV/m) = Raw Value(dBuV) + Correction Factor(dB/m)
2. Correction Factor(dB/m) = Antenna Factor(dB/m) + Cable Factor(dB) – Pre-Amplifier Factor(dB)
3. The other emission levels were very low against the limit.
4. Margin value = Emission Level – Limit value
5. " * ": Fundamental frequency.
6. " # ": The radiated frequency is out of the restricted band.



A D T

CHANNEL	TX Channel 106	DETECTOR FUNCTION	Peak (PK)
FREQUENCY RANGE	1GHz ~ 40GHz		Average (AV)

ANTENNA POLARITY & TEST DISTANCE: HORIZONTAL AT 3 M								
NO.	FREQ. (MHz)	EMISSION LEVEL (dBuV/m)	LIMIT (dBuV/m)	MARGIN (dB)	ANTENNA HEIGHT (m)	TABLE ANGLE (Degree)	RAW VALUE (dBuV)	CORRECTION FACTOR (dB/m)
1	5460.00	61.4 PK	74.0	-12.6	1.08 H	345	56.80	4.60
2	5460.00	48.0 AV	54.0	-6.0	1.08 H	345	43.40	4.60
3	#5470.00	67.6 PK	68.3	-0.7	1.06 H	193	63.00	4.60
4	*5530.00	104.3 PK			1.03 H	197	99.70	4.60
5	*5530.00	92.4 AV			1.03 H	197	87.80	4.60
6	#5725.00	53.7 PK	68.3	-14.6	1.00 H	15	48.80	4.90
7	11060.00	56.9 PK	74.0	-17.1	1.16 H	146	46.20	10.70
8	11060.00	43.3 AV	54.0	-10.7	1.16 H	146	32.60	10.70
9	#16590.00	62.6 PK	68.3	-5.7	1.03 H	169	45.50	17.10

ANTENNA POLARITY & TEST DISTANCE: VERTICAL AT 3 M								
NO.	FREQ. (MHz)	EMISSION LEVEL (dBuV/m)	LIMIT (dBuV/m)	MARGIN (dB)	ANTENNA HEIGHT (m)	TABLE ANGLE (Degree)	RAW VALUE (dBuV)	CORRECTION FACTOR (dB/m)
1	5460.00	65.9 PK	74.0	-8.1	1.13 V	180	61.30	4.60
2	5460.00	49.9 AV	54.0	-4.1	1.13 V	180	45.30	4.60
3	#5470.00	67.9 PK	68.3	-0.4	1.16 V	100	63.30	4.60
4	*5530.00	104.7 PK			1.15 V	99	100.10	4.60
5	*5530.00	93.7 AV			1.15 V	99	89.10	4.60
6	#5725.00	62.7 PK	68.3	-5.6	1.11 V	196	57.80	4.90
7	11060.00	54.2 PK	74.0	-19.8	1.22 V	67	43.50	10.70
8	11060.00	41.9 AV	54.0	-12.1	1.22 V	67	31.20	10.70
9	#16590.00	57.4 PK	68.3	-10.9	1.16 V	142	40.30	17.10

REMARKS:

1. Emission Level(dBuV/m) = Raw Value(dBuV) + Correction Factor(dB/m)
2. Correction Factor(dB/m) = Antenna Factor(dB/m) + Cable Factor(dB) – Pre-Amplifier Factor(dB)
3. The other emission levels were very low against the limit.
4. Margin value = Emission Level – Limit value
5. " * " : Fundamental frequency.
6. " # " : The radiated frequency is out of the restricted band.



A D T

CHANNEL	TX Channel 138	DETECTOR FUNCTION	Peak (PK)
FREQUENCY RANGE	1GHz ~ 40GHz		Average (AV)

ANTENNA POLARITY & TEST DISTANCE: HORIZONTAL AT 3 M

NO.	FREQ. (MHz)	EMISSION LEVEL (dBuV/m)	LIMIT (dBuV/m)	MARGIN (dB)	ANTENNA HEIGHT (m)	TABLE ANGLE (Degree)	RAW VALUE (dBuV)	CORRECTION FACTOR (dB/m)
1	*5690.00	105.2 PK			1.00 H	360	100.20	5.00
2	*5690.00	94.4 AV			1.00 H	360	89.40	5.00
3	#5837.00	64.5 PK	68.3	-3.8	1.15 H	184	59.40	5.10
4	11380.00	57.0 PK	74.0	-17.0	1.16 H	130	46.30	10.70
5	11380.00	43.3 AV	54.0	-10.7	1.16 H	130	32.60	10.70
6	#17070.00	62.2 PK	68.3	-6.1	1.00 H	163	43.70	18.50

ANTENNA POLARITY & TEST DISTANCE: VERTICAL AT 3 M

NO.	FREQ. (MHz)	EMISSION LEVEL (dBuV/m)	LIMIT (dBuV/m)	MARGIN (dB)	ANTENNA HEIGHT (m)	TABLE ANGLE (Degree)	RAW VALUE (dBuV)	CORRECTION FACTOR (dB/m)
1	*5690.00	110.5 PK			1.07 V	170	105.50	5.00
2	*5690.00	100.1 AV			1.07 V	170	95.10	5.00
3	#5837.00	67.8 PK	68.3	-0.5	1.04 V	159	62.70	5.10
4	11380.00	54.6 PK	74.0	-19.4	1.27 V	64	43.90	10.70
5	11380.00	42.1 AV	54.0	-11.9	1.27 V	64	31.40	10.70
6	#17070.00	57.4 PK	68.3	-10.9	1.15 V	138	38.90	18.50

REMARKS:

1. Emission Level(dBuV/m) = Raw Value(dBuV) + Correction Factor(dB/m)
2. Correction Factor(dB/m) = Antenna Factor(dB/m) + Cable Factor(dB) – Pre-Amplifier Factor(dB)
3. The other emission levels were very low against the limit.
4. Margin value = Emission Level – Limit value
5. " * ": Fundamental frequency.
6. " # ": The radiated frequency is out of the restricted band.



A D T

4.2.9 TEST RESULTS (MODE 2)

CDD_MODE

BELOW 1GHz WORST-CASE DATA

802.11ac (VHT20)

CHANNEL	TX Channel 144	DETECTOR FUNCTION	Quasi-Peak (QP)
FREQUENCY RANGE	30MHz ~ 1GHz		

ANTENNA POLARITY & TEST DISTANCE: HORIZONTAL AT 3 M								
NO.	FREQ. (MHz)	EMISSION LEVEL (dBuV/m)	LIMIT (dBuV/m)	MARGIN (dB)	ANTENNA HEIGHT (m)	TABLE ANGLE (Degree)	RAW VALUE (dBuV)	CORRECTION FACTOR (dB/m)
1	56.09	33.6 QP	40.0	-6.4	2.00 H	0	47.59	-13.96
2	125.01	39.7 QP	43.5	-3.8	1.50 H	77	54.52	-14.83
3	375.03	42.7 QP	46.0	-3.3	1.00 H	129	53.18	-10.51
4	625.01	42.2 QP	46.0	-3.8	1.50 H	360	46.67	-4.44
5	750.03	41.5 QP	46.0	-4.5	1.00 H	40	43.50	-2.01
6	875.02	42.9 QP	46.0	-3.2	1.50 H	245	43.33	-0.48

ANTENNA POLARITY & TEST DISTANCE: VERTICAL AT 3 M								
NO.	FREQ. (MHz)	EMISSION LEVEL (dBuV/m)	LIMIT (dBuV/m)	MARGIN (dB)	ANTENNA HEIGHT (m)	TABLE ANGLE (Degree)	RAW VALUE (dBuV)	CORRECTION FACTOR (dB/m)
1	49.82	37.8 QP	40.0	-2.2	1.00 V	200	51.56	-13.73
2	64.92	37.7 QP	40.0	-2.3	1.50 V	360	52.45	-14.79
3	375.00	44.9 QP	46.0	-1.1	1.50 V	132	55.44	-10.52
4	625.00	41.0 QP	46.0	-5.0	1.00 V	304	45.47	-4.45
5	749.98	39.3 QP	46.0	-6.8	1.50 V	67	41.26	-2.01
6	875.02	41.8 QP	46.0	-4.2	1.00 V	88	42.26	-0.48

REMARKS:

1. Emission Level(dBuV/m) = Raw Value(dBuV) + Correction Factor(dB/m)
2. Correction Factor(dB/m) = Antenna Factor(dB/m) + Cable Factor(dB) – Pre-Amplifier Factor(dB)
3. The other emission levels were very low against the limit.
4. Margin value = Emission Level – Limit value



A D T

ABOVE 1GHz DATA

802.11ac (VHT20)

CHANNEL	TX Channel 52	DETECTOR FUNCTION	Peak (PK)
FREQUENCY RANGE	1GHz ~ 40GHz		Average (AV)

ANTENNA POLARITY & TEST DISTANCE: HORIZONTAL AT 3 M

NO.	FREQ. (MHz)	EMISSION LEVEL (dBuV/m)	LIMIT (dBuV/m)	MARGIN (dB)	ANTENNA HEIGHT (m)	TABLE ANGLE (Degree)	RAW VALUE (dBuV)	CORRECTION FACTOR (dB/m)
1	*5260.00	103.2 PK			1.19 H	8	98.80	4.40
2	*5260.00	91.9 AV			1.19 H	8	87.50	4.40
3	5422.00	56.3 PK	74.0	-17.7	1.03 H	192	51.70	4.60
4	5422.00	45.0 AV	54.0	-9.0	1.03 H	192	40.40	4.60
5	#10520.00	56.8 PK	68.3	-11.5	1.21 H	126	46.40	10.40
6	15780.00	60.0 PK	74.0	-14.0	1.14 H	141	45.30	14.70
7	15780.00	47.8 AV	54.0	-6.2	1.14 H	141	33.10	14.70

ANTENNA POLARITY & TEST DISTANCE: VERTICAL AT 3 M

NO.	FREQ. (MHz)	EMISSION LEVEL (dBuV/m)	LIMIT (dBuV/m)	MARGIN (dB)	ANTENNA HEIGHT (m)	TABLE ANGLE (Degree)	RAW VALUE (dBuV)	CORRECTION FACTOR (dB/m)
1	*5260.00	107.2 PK			1.06 V	160	102.80	4.40
2	*5260.00	97.4 AV			1.06 V	160	93.00	4.40
3	5422.00	67.3 PK	74.0	-6.7	1.03 V	154	62.70	4.60
4	5422.00	53.7 AV	54.0	-0.3	1.03 V	154	49.10	4.60
5	#10520.00	54.4 PK	68.3	-13.9	1.09 V	89	44.00	10.40
6	15780.00	57.1 PK	74.0	-16.9	1.26 V	75	42.40	14.70
7	15780.00	45.7 AV	54.0	-8.3	1.26 V	75	31.00	14.70

REMARKS:

1. Emission Level(dBuV/m) = Raw Value(dBuV) + Correction Factor(dB/m)
2. Correction Factor(dB/m) = Antenna Factor(dB/m) + Cable Factor(dB) – Pre-Amplifier Factor(dB)
3. The other emission levels were very low against the limit.
4. Margin value = Emission Level – Limit value
5. " * ": Fundamental frequency.
6. " # ": The radiated frequency is out of the restricted band.



A D T

CHANNEL	TX Channel 60	DETECTOR FUNCTION	Peak (PK)
FREQUENCY RANGE	1GHz ~ 40GHz		Average (AV)

ANTENNA POLARITY & TEST DISTANCE: HORIZONTAL AT 3 M

NO.	FREQ. (MHz)	EMISSION LEVEL (dBuV/m)	LIMIT (dBuV/m)	MARGIN (dB)	ANTENNA HEIGHT (m)	TABLE ANGLE (Degree)	RAW VALUE (dBuV)	CORRECTION FACTOR (dB/m)
1	*5300.00	103.5 PK			1.16 H	12	99.10	4.40
2	*5300.00	92.2 AV			1.16 H	12	87.80	4.40
3	5378.00	61.7 PK	74.0	-12.3	1.06 H	360	57.00	4.70
4	5378.00	50.8 AV	54.0	-3.2	1.06 H	360	46.10	4.70
5	#5461.00	56.2 PK	68.3	-12.1	1.06 H	10	51.60	4.60
6	10600.00	56.5 PK	74.0	-17.5	1.25 H	120	45.90	10.60
7	10600.00	43.6 AV	54.0	-10.4	1.25 H	120	33.00	10.60
8	15900.00	60.3 PK	74.0	-13.7	1.09 H	155	45.20	15.10
9	15900.00	48.2 AV	54.0	-5.8	1.09 H	155	33.10	15.10

ANTENNA POLARITY & TEST DISTANCE: VERTICAL AT 3 M

NO.	FREQ. (MHz)	EMISSION LEVEL (dBuV/m)	LIMIT (dBuV/m)	MARGIN (dB)	ANTENNA HEIGHT (m)	TABLE ANGLE (Degree)	RAW VALUE (dBuV)	CORRECTION FACTOR (dB/m)
1	*5300.00	107.8 PK			1.05 V	156	103.40	4.40
2	*5300.00	97.5 AV			1.05 V	156	93.10	4.40
3	5378.00	63.9 PK	74.0	-10.1	1.04 V	158	59.20	4.70
4	5378.00	53.7 AV	54.0	-0.3	1.04 V	158	49.00	4.70
5	#5461.00	63.6 PK	68.3	-4.7	1.22 V	161	59.00	4.60
6	10600.00	54.3 PK	74.0	-19.7	1.13 V	96	43.70	10.60
7	10600.00	41.8 AV	54.0	-12.2	1.13 V	96	31.20	10.60
8	15900.00	57.6 PK	74.0	-16.4	1.23 V	72	42.50	15.10
9	15900.00	46.0 AV	54.0	-8.0	1.23 V	72	30.90	15.10

REMARKS:

1. Emission Level(dBuV/m) = Raw Value(dBuV) + Correction Factor(dB/m)
2. Correction Factor(dB/m) = Antenna Factor(dB/m) + Cable Factor(dB) – Pre-Amplifier Factor(dB)
3. The other emission levels were very low against the limit.
4. Margin value = Emission Level – Limit value
5. " * ": Fundamental frequency.
6. " # ": The radiated frequency is out of the restricted band.



A D T

CHANNEL	TX Channel 64	DETECTOR FUNCTION	Peak (PK)
FREQUENCY RANGE	1GHz ~ 40GHz		Average (AV)

ANTENNA POLARITY & TEST DISTANCE: HORIZONTAL AT 3 M

NO.	FREQ. (MHz)	EMISSION LEVEL (dBuV/m)	LIMIT (dBuV/m)	MARGIN (dB)	ANTENNA HEIGHT (m)	TABLE ANGLE (Degree)	RAW VALUE (dBuV)	CORRECTION FACTOR (dB/m)
1	*5320.00	103.7 PK			1.12 H	6	99.30	4.40
2	*5320.00	92.3 AV			1.12 H	6	87.90	4.40
3	5400.00	62.0 PK	74.0	-12.0	1.06 H	5	57.30	4.70
4	5400.00	51.2 AV	54.0	-2.8	1.06 H	5	46.50	4.70
5	10640.00	56.0 PK	74.0	-18.0	1.23 H	127	45.40	10.60
6	10640.00	43.3 AV	54.0	-10.7	1.23 H	127	32.70	10.60
7	15960.00	59.7 PK	74.0	-14.3	1.05 H	147	44.80	14.90
8	15960.00	47.8 AV	54.0	-6.2	1.05 H	147	32.90	14.90

ANTENNA POLARITY & TEST DISTANCE: VERTICAL AT 3 M

NO.	FREQ. (MHz)	EMISSION LEVEL (dBuV/m)	LIMIT (dBuV/m)	MARGIN (dB)	ANTENNA HEIGHT (m)	TABLE ANGLE (Degree)	RAW VALUE (dBuV)	CORRECTION FACTOR (dB/m)
1	*5320.00	106.9 PK			1.05 V	154	102.50	4.40
2	*5320.00	97.3 AV			1.05 V	154	92.90	4.40
3	5400.00	63.7 PK	74.0	-10.3	1.02 V	151	59.00	4.70
4	5400.00	53.6 AV	54.0	-0.4	1.02 V	151	48.90	4.70
5	10640.00	54.3 PK	74.0	-19.7	1.17 V	81	43.70	10.60
6	10640.00	41.7 AV	54.0	-12.3	1.17 V	81	31.10	10.60
7	15960.00	57.5 PK	74.0	-16.5	1.22 V	77	42.60	14.90
8	15960.00	45.9 AV	54.0	-8.1	1.22 V	77	31.00	14.90

REMARKS:

1. Emission Level(dBuV/m) = Raw Value(dBuV) + Correction Factor(dB/m)
2. Correction Factor(dB/m) = Antenna Factor(dB/m) + Cable Factor(dB) – Pre-Amplifier Factor(dB)
3. The other emission levels were very low against the limit.
4. Margin value = Emission Level – Limit value
5. " * ": Fundamental frequency.



A D T

CHANNEL	TX Channel 100	DETECTOR FUNCTION	Peak (PK)
FREQUENCY RANGE	1GHz ~ 40GHz		Average (AV)

ANTENNA POLARITY & TEST DISTANCE: HORIZONTAL AT 3 M

NO.	FREQ. (MHz)	EMISSION LEVEL (dBuV/m)	LIMIT (dBuV/m)	MARGIN (dB)	ANTENNA HEIGHT (m)	TABLE ANGLE (Degree)	RAW VALUE (dBuV)	CORRECTION FACTOR (dB/m)
1	5421.00	64.8 PK	74.0	-9.2	1.04 H	182	60.20	4.60
2	5421.00	53.0 AV	54.0	-1.0	1.04 H	182	48.40	4.60
3	*5500.00	103.9 PK			1.11 H	6	99.30	4.60
4	*5500.00	93.4 AV			1.11 H	6	88.80	4.60
5	11000.00	55.5 PK	74.0	-18.5	1.22 H	122	44.70	10.80
6	11000.00	42.9 AV	54.0	-11.1	1.22 H	122	32.10	10.80
7	#16500.00	60.0 PK	68.3	-8.3	1.05 H	132	43.00	17.00

ANTENNA POLARITY & TEST DISTANCE: VERTICAL AT 3 M

NO.	FREQ. (MHz)	EMISSION LEVEL (dBuV/m)	LIMIT (dBuV/m)	MARGIN (dB)	ANTENNA HEIGHT (m)	TABLE ANGLE (Degree)	RAW VALUE (dBuV)	CORRECTION FACTOR (dB/m)
1	5421.00	63.6 PK	74.0	-10.4	1.03 V	152	59.00	4.60
2	5421.00	53.7 AV	54.0	-0.3	1.03 V	152	49.10	4.60
3	*5500.00	108.5 PK			1.04 V	146	103.90	4.60
4	*5500.00	98.7 AV			1.04 V	146	94.10	4.60
5	11000.00	54.6 PK	74.0	-19.4	1.14 V	82	43.80	10.80
6	11000.00	41.8 AV	54.0	-12.2	1.14 V	82	31.00	10.80
7	#16500.00	57.6 PK	68.3	-10.7	1.26 V	81	40.60	17.00

REMARKS:

1. Emission Level(dBuV/m) = Raw Value(dBuV) + Correction Factor(dB/m)
2. Correction Factor(dB/m) = Antenna Factor(dB/m) + Cable Factor(dB) – Pre-Amplifier Factor(dB)
3. The other emission levels were very low against the limit.
4. Margin value = Emission Level – Limit value
5. " * ": Fundamental frequency.
6. " # ": The radiated frequency is out of the restricted band.



A D T

CHANNEL	TX Channel 116	DETECTOR FUNCTION	Peak (PK)
FREQUENCY RANGE	1GHz ~ 40GHz		Average (AV)

ANTENNA POLARITY & TEST DISTANCE: HORIZONTAL AT 3 M

NO.	FREQ. (MHz)	EMISSION LEVEL (dBuV/m)	LIMIT (dBuV/m)	MARGIN (dB)	ANTENNA HEIGHT (m)	TABLE ANGLE (Degree)	RAW VALUE (dBuV)	CORRECTION FACTOR (dB/m)
1	5417.00	58.2 PK	74.0	-15.8	1.04 H	166	53.60	4.60
2	5417.00	47.7 AV	54.0	-6.3	1.04 H	166	43.10	4.60
3	*5580.00	106.3 PK			1.10 H	13	101.40	4.90
4	*5580.00	96.4 AV			1.10 H	13	91.50	4.90
5	#5740.00	59.1 PK	68.3	-9.2	1.09 H	171	54.20	4.90
6	11160.00	55.9 PK	74.0	-18.1	1.18 H	133	45.20	10.70
7	11160.00	43.1 AV	54.0	-10.9	1.18 H	133	32.40	10.70
8	#16740.00	59.8 PK	68.3	-8.5	1.07 H	138	41.90	17.90

ANTENNA POLARITY & TEST DISTANCE: VERTICAL AT 3 M

NO.	FREQ. (MHz)	EMISSION LEVEL (dBuV/m)	LIMIT (dBuV/m)	MARGIN (dB)	ANTENNA HEIGHT (m)	TABLE ANGLE (Degree)	RAW VALUE (dBuV)	CORRECTION FACTOR (dB/m)
1	5417.00	63.7 PK	74.0	-10.3	1.06 V	147	59.10	4.60
2	5417.00	53.3 AV	54.0	-0.7	1.06 V	147	48.70	4.60
3	*5580.00	110.7 PK			1.03 V	144	105.80	4.90
4	*5580.00	101.1 AV			1.03 V	144	96.20	4.90
5	#5740.00	67.8 PK	68.3	-0.5	1.00 V	145	62.90	4.90
6	11160.00	54.4 PK	74.0	-19.6	1.18 V	96	43.70	10.70
7	11160.00	41.8 AV	54.0	-12.2	1.18 V	96	31.10	10.70
8	#16740.00	57.7 PK	68.3	-10.6	1.27 V	75	39.80	17.90

REMARKS:

1. Emission Level(dBuV/m) = Raw Value(dBuV) + Correction Factor(dB/m)
2. Correction Factor(dB/m) = Antenna Factor(dB/m) + Cable Factor(dB) – Pre-Amplifier Factor(dB)
3. The other emission levels were very low against the limit.
4. Margin value = Emission Level – Limit value
5. " * ": Fundamental frequency.
6. " # ": The radiated frequency is out of the restricted band.



A D T

CHANNEL	TX Channel 132	DETECTOR FUNCTION	Peak (PK)
FREQUENCY RANGE	1GHz ~ 40GHz		Average (AV)

ANTENNA POLARITY & TEST DISTANCE: HORIZONTAL AT 3 M

NO.	FREQ. (MHz)	EMISSION LEVEL (dBuV/m)	LIMIT (dBuV/m)	MARGIN (dB)	ANTENNA HEIGHT (m)	TABLE ANGLE (Degree)	RAW VALUE (dBuV)	CORRECTION FACTOR (dB/m)
1	*5660.00	106.2 PK			1.02 H	18	101.30	4.90
2	*5660.00	96.1 AV			1.02 H	18	91.20	4.90
3	#5741.00	65.5 PK	68.3	-2.8	1.19 H	356	60.60	4.90
4	#5821.00	60.0 PK	68.3	-8.3	1.17 H	11	54.90	5.10
5	11320.00	56.0 PK	74.0	-18.0	1.20 H	145	45.20	10.80
6	11320.00	43.0 AV	54.0	-11.0	1.20 H	145	32.20	10.80
7	#16980.00	60.3 PK	68.3	-8.0	1.02 H	130	41.90	18.40

ANTENNA POLARITY & TEST DISTANCE: VERTICAL AT 3 M

NO.	FREQ. (MHz)	EMISSION LEVEL (dBuV/m)	LIMIT (dBuV/m)	MARGIN (dB)	ANTENNA HEIGHT (m)	TABLE ANGLE (Degree)	RAW VALUE (dBuV)	CORRECTION FACTOR (dB/m)
1	*5660.00	110.4 PK			1.04 V	101	105.50	4.90
2	*5660.00	100.8 AV			1.04 V	101	95.90	4.90
3	#5741.00	67.1 PK	68.3	-1.2	1.03 V	93	62.20	4.90
4	#5821.00	67.9 PK	68.3	-0.4	1.22 V	92	62.80	5.10
5	11320.00	54.3 PK	74.0	-19.7	1.13 V	83	43.50	10.80
6	11320.00	41.8 AV	54.0	-12.2	1.13 V	83	31.00	10.80
7	#16980.00	57.5 PK	68.3	-10.8	1.23 V	72	39.10	18.40

REMARKS:

1. Emission Level(dBuV/m) = Raw Value(dBuV) + Correction Factor(dB/m)
2. Correction Factor(dB/m) = Antenna Factor(dB/m) + Cable Factor(dB) – Pre-Amplifier Factor(dB)
3. The other emission levels were very low against the limit.
4. Margin value = Emission Level – Limit value
5. " * ": Fundamental frequency.
6. " # ": The radiated frequency is out of the restricted band.



A D T

CHANNEL	TX Channel 140	DETECTOR FUNCTION	Peak (PK)
FREQUENCY RANGE	1GHz ~ 40GHz		Average (AV)

ANTENNA POLARITY & TEST DISTANCE: HORIZONTAL AT 3 M

NO.	FREQ. (MHz)	EMISSION LEVEL (dBuV/m)	LIMIT (dBuV/m)	MARGIN (dB)	ANTENNA HEIGHT (m)	TABLE ANGLE (Degree)	RAW VALUE (dBuV)	CORRECTION FACTOR (dB/m)
1	*5700.00	106.7 PK			1.08 H	12	101.80	4.90
2	*5700.00	96.2 AV			1.08 H	12	91.30	4.90
3	#5781.00	65.0 PK	68.3	-3.3	1.18 H	360	60.10	4.90
4	#5859.00	57.8 PK	68.3	-10.5	1.25 H	358	52.70	5.10
5	11400.00	56.4 PK	74.0	-17.6	1.25 H	137	45.70	10.70
6	11400.00	43.4 AV	54.0	-10.6	1.25 H	137	32.70	10.70
7	#17100.00	60.0 PK	68.3	-8.3	1.00 H	117	41.40	18.60

ANTENNA POLARITY & TEST DISTANCE: VERTICAL AT 3 M

NO.	FREQ. (MHz)	EMISSION LEVEL (dBuV/m)	LIMIT (dBuV/m)	MARGIN (dB)	ANTENNA HEIGHT (m)	TABLE ANGLE (Degree)	RAW VALUE (dBuV)	CORRECTION FACTOR (dB/m)
1	*5700.00	110.2 PK			1.04 V	85	105.30	4.90
2	*5700.00	100.6 AV			1.04 V	85	95.70	4.90
3	#5781.00	67.6 PK	68.3	-0.7	1.06 V	158	62.70	4.90
4	#5859.00	68.1 PK	68.3	-0.2	1.04 V	153	63.00	5.10
5	11400.00	54.1 PK	74.0	-19.9	1.15 V	83	43.40	10.70
6	11400.00	41.6 AV	54.0	-12.4	1.15 V	83	30.90	10.70
7	#17100.00	58.1 PK	68.3	-10.2	1.21 V	83	39.50	18.60

REMARKS:

1. Emission Level(dBuV/m) = Raw Value(dBuV) + Correction Factor(dB/m)
2. Correction Factor(dB/m) = Antenna Factor(dB/m) + Cable Factor(dB) – Pre-Amplifier Factor(dB)
3. The other emission levels were very low against the limit.
4. Margin value = Emission Level – Limit value
5. " * ": Fundamental frequency.
6. " # ": The radiated frequency is out of the restricted band.



A D T

CHANNEL	TX Channel 144	DETECTOR FUNCTION	Peak (PK)
FREQUENCY RANGE	1GHz ~ 40GHz		Average (AV)

ANTENNA POLARITY & TEST DISTANCE: HORIZONTAL AT 3 M

NO.	FREQ. (MHz)	EMISSION LEVEL (dBuV/m)	LIMIT (dBuV/m)	MARGIN (dB)	ANTENNA HEIGHT (m)	TABLE ANGLE (Degree)	RAW VALUE (dBuV)	CORRECTION FACTOR (dB/m)
1	*5720.00	112.7 PK			1.20 H	358	107.80	4.90
2	*5720.00	101.3 AV			1.20 H	358	96.40	4.90
3	#5881.00	60.3 PK	68.3	-8.0	1.15 H	173	55.20	5.10
4	11440.00	56.0 PK	74.0	-18.0	1.28 H	141	45.40	10.60
5	11440.00	42.9 AV	54.0	-11.1	1.28 H	141	32.30	10.60
6	#17160.00	60.2 PK	68.3	-8.1	1.03 H	120	41.10	19.10

ANTENNA POLARITY & TEST DISTANCE: VERTICAL AT 3 M

NO.	FREQ. (MHz)	EMISSION LEVEL (dBuV/m)	LIMIT (dBuV/m)	MARGIN (dB)	ANTENNA HEIGHT (m)	TABLE ANGLE (Degree)	RAW VALUE (dBuV)	CORRECTION FACTOR (dB/m)
1	*5720.00	111.3 PK			1.04 V	86	106.40	4.90
2	*5720.00	102.1 AV			1.04 V	86	97.20	4.90
3	#5881.00	68.0 PK	68.3	-0.3	1.03 V	155	62.90	5.10
4	11440.00	54.3 PK	74.0	-19.7	1.20 V	89	43.70	10.60
5	11440.00	41.8 AV	54.0	-12.2	1.20 V	89	31.20	10.60
6	#17160.00	58.6 PK	68.3	-9.7	1.26 V	86	39.50	19.10

REMARKS:

1. Emission Level(dBuV/m) = Raw Value(dBuV) + Correction Factor(dB/m)
2. Correction Factor(dB/m) = Antenna Factor(dB/m) + Cable Factor(dB) – Pre-Amplifier Factor(dB)
3. The other emission levels were very low against the limit.
4. Margin value = Emission Level – Limit value
5. " * ": Fundamental frequency.
6. " # ": The radiated frequency is out of the restricted band.



A D T

802.11ac (VHT40)

CHANNEL	TX Channel 54	DETECTOR FUNCTION	Peak (PK)
FREQUENCY RANGE	1GHz ~ 40GHz		Average (AV)

ANTENNA POLARITY & TEST DISTANCE: HORIZONTAL AT 3 M

NO.	FREQ. (MHz)	EMISSION LEVEL (dBuV/m)	LIMIT (dBuV/m)	MARGIN (dB)	ANTENNA HEIGHT (m)	TABLE ANGLE (Degree)	RAW VALUE (dBuV)	CORRECTION FACTOR (dB/m)
1	*5270.00	105.5 PK			1.06 H	133	101.20	4.30
2	*5270.00	95.2 AV			1.06 H	133	90.90	4.30
3	5352.00	61.8 PK	74.0	-12.2	1.06 H	174	57.40	4.40
4	5352.00	51.0 AV	54.0	-3.0	1.06 H	174	46.60	4.40
5	5424.00	58.0 PK	74.0	-16.0	1.22 H	165	53.40	4.60
6	5424.00	47.1 AV	54.0	-6.9	1.22 H	165	42.50	4.60
7	#10540.00	56.6 PK	68.3	-11.7	1.29 H	154	46.20	10.40
8	15810.00	59.9 PK	74.0	-14.1	1.01 H	132	45.10	14.80
9	15810.00	47.4 AV	54.0	-6.6	1.01 H	132	32.60	14.80

ANTENNA POLARITY & TEST DISTANCE: VERTICAL AT 3 M

NO.	FREQ. (MHz)	EMISSION LEVEL (dBuV/m)	LIMIT (dBuV/m)	MARGIN (dB)	ANTENNA HEIGHT (m)	TABLE ANGLE (Degree)	RAW VALUE (dBuV)	CORRECTION FACTOR (dB/m)
1	*5270.00	107.8 PK			1.30 V	90	103.50	4.30
2	*5270.00	98.3 AV			1.30 V	90	94.00	4.30
3	5352.00	63.3 PK	74.0	-10.7	1.30 V	98	58.90	4.40
4	5352.00	53.5 AV	54.0	-0.5	1.30 V	98	49.10	4.40
5	5424.00	63.6 PK	74.0	-10.4	1.28 V	91	59.00	4.60
6	5424.00	53.7 AV	54.0	-0.3	1.28 V	91	49.10	4.60
7	#10540.00	54.9 PK	68.3	-13.4	1.24 V	76	44.50	10.40
8	15810.00	58.5 PK	74.0	-15.5	1.24 V	75	43.70	14.80
9	15810.00	46.3 AV	54.0	-7.7	1.24 V	75	31.50	14.80

REMARKS:

1. Emission Level(dBuV/m) = Raw Value(dBuV) + Correction Factor(dB/m)
2. Correction Factor(dB/m) = Antenna Factor(dB/m) + Cable Factor(dB) – Pre-Amplifier Factor(dB)
3. The other emission levels were very low against the limit.
4. Margin value = Emission Level – Limit value
5. " * ": Fundamental frequency.
6. " # ": The radiated frequency is out of the restricted band.



A D T

CHANNEL	TX Channel 62	DETECTOR FUNCTION	Peak (PK)
FREQUENCY RANGE	1GHz ~ 40GHz		Average (AV)

ANTENNA POLARITY & TEST DISTANCE: HORIZONTAL AT 3 M								
NO.	FREQ. (MHz)	EMISSION LEVEL (dBuV/m)	LIMIT (dBuV/m)	MARGIN (dB)	ANTENNA HEIGHT (m)	TABLE ANGLE (Degree)	RAW VALUE (dBuV)	CORRECTION FACTOR (dB/m)
1	*5310.00	105.1 PK			1.03 H	126	100.70	4.40
2	*5310.00	95.0 AV			1.03 H	126	90.60	4.40
3	5394.00	68.4 PK	74.0	-5.6	1.05 H	168	63.70	4.70
4	5394.00	52.1 AV	54.0	-1.9	1.05 H	168	47.40	4.70
5	#5470.00	58.2 PK	68.3	-10.1	1.01 H	181	53.60	4.60
6	10620.00	56.3 PK	74.0	-17.7	1.31 H	151	45.70	10.60
7	10620.00	43.2 AV	54.0	-10.8	1.31 H	151	32.60	10.60
8	15930.00	60.3 PK	74.0	-13.7	1.00 H	133	45.40	14.90
9	15930.00	47.6 AV	54.0	-6.4	1.00 H	133	32.70	14.90

ANTENNA POLARITY & TEST DISTANCE: VERTICAL AT 3 M								
NO.	FREQ. (MHz)	EMISSION LEVEL (dBuV/m)	LIMIT (dBuV/m)	MARGIN (dB)	ANTENNA HEIGHT (m)	TABLE ANGLE (Degree)	RAW VALUE (dBuV)	CORRECTION FACTOR (dB/m)
1	*5310.00	108.1 PK			1.10 V	89	103.70	4.40
2	*5310.00	98.4 AV			1.10 V	89	94.00	4.40
3	5394.00	65.3 PK	74.0	-8.7	1.04 V	185	60.60	4.70
4	5394.00	53.6 AV	54.0	-0.4	1.04 V	185	48.90	4.70
5	#5470.00	59.3 PK	68.3	-9.0	1.02 V	180	54.70	4.60
6	10620.00	54.8 PK	74.0	-19.2	1.22 V	83	44.20	10.60
7	10620.00	41.9 AV	54.0	-12.1	1.22 V	83	31.30	10.60
8	15930.00	58.5 PK	74.0	-15.5	1.21 V	70	43.60	14.90
9	15930.00	46.1 AV	54.0	-7.9	1.21 V	70	31.20	14.90

REMARKS:

1. Emission Level(dBuV/m) = Raw Value(dBuV) + Correction Factor(dB/m)
2. Correction Factor(dB/m) = Antenna Factor(dB/m) + Cable Factor(dB) – Pre-Amplifier Factor(dB)
3. The other emission levels were very low against the limit.
4. Margin value = Emission Level – Limit value
5. " * " : Fundamental frequency.
6. " # " : The radiated frequency is out of the restricted band.



A D T

CHANNEL	TX Channel 102	DETECTOR FUNCTION	Peak (PK)
FREQUENCY RANGE	1GHz ~ 40GHz		Average (AV)

ANTENNA POLARITY & TEST DISTANCE: HORIZONTAL AT 3 M

NO.	FREQ. (MHz)	EMISSION LEVEL (dBuV/m)	LIMIT (dBuV/m)	MARGIN (dB)	ANTENNA HEIGHT (m)	TABLE ANGLE (Degree)	RAW VALUE (dBuV)	CORRECTION FACTOR (dB/m)
1	5434.00	65.8 PK	74.0	-8.2	1.12 H	176	61.10	4.70
2	5434.00	50.7 AV	54.0	-3.3	1.12 H	176	46.00	4.70
3	#5470.00	67.2 PK	68.3	-1.1	1.14 H	152	62.60	4.60
4	*5510.00	104.9 PK			1.09 H	117	100.30	4.60
5	*5510.00	96.3 AV			1.09 H	117	91.70	4.60
6	11020.00	56.5 PK	74.0	-17.5	1.30 H	167	45.70	10.80
7	11020.00	43.4 AV	54.0	-10.6	1.30 H	167	32.60	10.80
8	#16530.00	60.7 PK	68.3	-7.6	1.00 H	131	43.60	17.10

ANTENNA POLARITY & TEST DISTANCE: VERTICAL AT 3 M

NO.	FREQ. (MHz)	EMISSION LEVEL (dBuV/m)	LIMIT (dBuV/m)	MARGIN (dB)	ANTENNA HEIGHT (m)	TABLE ANGLE (Degree)	RAW VALUE (dBuV)	CORRECTION FACTOR (dB/m)
1	5434.00	65.4 PK	74.0	-8.6	1.03 V	181	60.70	4.70
2	5434.00	50.9 AV	54.0	-3.1	1.03 V	181	46.20	4.70
3	#5470.00	67.9 PK	68.3	-0.4	1.03 V	181	63.30	4.60
4	*5510.00	107.8 PK			1.22 V	112	103.20	4.60
5	*5510.00	99.1 AV			1.22 V	112	94.50	4.60
6	11020.00	54.2 PK	74.0	-19.8	1.23 V	81	43.40	10.80
7	11020.00	41.4 AV	54.0	-12.6	1.23 V	81	30.60	10.80
8	#16530.00	58.7 PK	68.3	-9.6	1.24 V	76	41.60	17.10

REMARKS:

1. Emission Level(dBuV/m) = Raw Value(dBuV) + Correction Factor(dB/m)
2. Correction Factor(dB/m) = Antenna Factor(dB/m) + Cable Factor(dB) – Pre-Amplifier Factor(dB)
3. The other emission levels were very low against the limit.
4. Margin value = Emission Level – Limit value
5. " * ": Fundamental frequency.
6. " # ": The radiated frequency is out of the restricted band.



A D T

CHANNEL	TX Channel 110	DETECTOR FUNCTION	Peak (PK)
FREQUENCY RANGE	1GHz ~ 40GHz		Average (AV)

ANTENNA POLARITY & TEST DISTANCE: HORIZONTAL AT 3 M

NO.	FREQ. (MHz)	EMISSION LEVEL (dBuV/m)	LIMIT (dBuV/m)	MARGIN (dB)	ANTENNA HEIGHT (m)	TABLE ANGLE (Degree)	RAW VALUE (dBuV)	CORRECTION FACTOR (dB/m)
1	5460.00	65.9 PK	74.0	-8.1	1.24 H	174	61.30	4.60
2	5460.00	52.1 AV	54.0	-1.9	1.24 H	174	47.50	4.60
3	#5470.00	68.0 PK	68.3	-0.3	1.03 H	175	63.40	4.60
4	*5550.00	107.5 PK			1.21 H	180	102.80	4.70
5	*5550.00	96.3 AV			1.21 H	180	91.60	4.70
6	11100.00	56.3 PK	74.0	-17.7	1.27 H	158	45.60	10.70
7	11100.00	43.1 AV	54.0	-10.9	1.27 H	158	32.40	10.70
8	#16650.00	60.7 PK	68.3	-7.6	1.03 H	130	43.20	17.50

ANTENNA POLARITY & TEST DISTANCE: VERTICAL AT 3 M

NO.	FREQ. (MHz)	EMISSION LEVEL (dBuV/m)	LIMIT (dBuV/m)	MARGIN (dB)	ANTENNA HEIGHT (m)	TABLE ANGLE (Degree)	RAW VALUE (dBuV)	CORRECTION FACTOR (dB/m)
1	5460.00	66.6 PK	74.0	-7.4	1.03 V	179	62.00	4.60
2	5460.00	51.8 AV	54.0	-2.2	1.03 V	179	47.20	4.60
3	#5470.00	67.8 PK	68.3	-0.5	1.03 V	179	63.20	4.60
4	*5550.00	108.2 PK			1.20 V	121	103.50	4.70
5	*5550.00	99.2 AV			1.20 V	121	94.50	4.70
6	11100.00	54.2 PK	74.0	-19.8	1.19 V	84	43.50	10.70
7	11100.00	41.4 AV	54.0	-12.6	1.19 V	84	30.70	10.70
8	#16650.00	58.4 PK	68.3	-9.9	1.20 V	90	40.90	17.50

REMARKS:

1. Emission Level(dBuV/m) = Raw Value(dBuV) + Correction Factor(dB/m)
2. Correction Factor(dB/m) = Antenna Factor(dB/m) + Cable Factor(dB) – Pre-Amplifier Factor(dB)
3. The other emission levels were very low against the limit.
4. Margin value = Emission Level – Limit value
5. " * ": Fundamental frequency.
6. " # ": The radiated frequency is out of the restricted band.



A D T

CHANNEL	TX Channel 134	DETECTOR FUNCTION	Peak (PK)
FREQUENCY RANGE	1GHz ~ 40GHz		Average (AV)

ANTENNA POLARITY & TEST DISTANCE: HORIZONTAL AT 3 M

NO.	FREQ. (MHz)	EMISSION LEVEL (dBuV/m)	LIMIT (dBuV/m)	MARGIN (dB)	ANTENNA HEIGHT (m)	TABLE ANGLE (Degree)	RAW VALUE (dBuV)	CORRECTION FACTOR (dB/m)
1	*5670.00	107.2 PK			1.16 H	162	102.30	4.90
2	*5670.00	96.9 AV			1.16 H	162	92.00	4.90
3	#5737.00	67.2 PK	68.3	-1.1	1.16 H	169	62.30	4.90
4	#5830.00	59.5 PK	68.3	-8.8	1.14 H	172	54.40	5.10
5	11340.00	56.3 PK	74.0	-17.7	1.27 H	166	45.50	10.80
6	11340.00	43.3 AV	54.0	-10.7	1.27 H	166	32.50	10.80
7	#17010.00	61.4 PK	68.3	-6.9	1.00 H	128	43.00	18.40

ANTENNA POLARITY & TEST DISTANCE: VERTICAL AT 3 M

NO.	FREQ. (MHz)	EMISSION LEVEL (dBuV/m)	LIMIT (dBuV/m)	MARGIN (dB)	ANTENNA HEIGHT (m)	TABLE ANGLE (Degree)	RAW VALUE (dBuV)	CORRECTION FACTOR (dB/m)
1	*5670.00	108.9 PK			1.18 V	96	104.00	4.90
2	*5670.00	99.7 AV			1.18 V	96	94.80	4.90
3	#5737.00	67.9 PK	68.3	-0.4	1.16 V	177	63.00	4.90
4	#5830.00	56.7 PK	68.3	-11.6	1.00 V	170	51.60	5.10
5	11340.00	54.7 PK	74.0	-19.3	1.19 V	96	43.90	10.80
6	11340.00	41.9 AV	54.0	-12.1	1.19 V	96	31.10	10.80
7	#17010.00	58.6 PK	68.3	-9.7	1.20 V	104	40.20	18.40

REMARKS:

1. Emission Level(dBuV/m) = Raw Value(dBuV) + Correction Factor(dB/m)
2. Correction Factor(dB/m) = Antenna Factor(dB/m) + Cable Factor(dB) – Pre-Amplifier Factor(dB)
3. The other emission levels were very low against the limit.
4. Margin value = Emission Level – Limit value
5. " * ": Fundamental frequency.
6. " # ": The radiated frequency is out of the restricted band.



A D T

CHANNEL	TX Channel 142	DETECTOR FUNCTION	Peak (PK)
FREQUENCY RANGE	1GHz ~ 40GHz		Average (AV)

ANTENNA POLARITY & TEST DISTANCE: HORIZONTAL AT 3 M

NO.	FREQ. (MHz)	EMISSION LEVEL (dBuV/m)	LIMIT (dBuV/m)	MARGIN (dB)	ANTENNA HEIGHT (m)	TABLE ANGLE (Degree)	RAW VALUE (dBuV)	CORRECTION FACTOR (dB/m)
1	#5470.00	66.7 PK	68.3	-1.6	1.02 H	175	62.10	4.60
2	*5710.00	113.0 PK			1.17 H	165	108.10	4.90
3	*5710.00	102.4 AV			1.17 H	165	97.50	4.90
4	#5865.00	66.6 PK	68.3	-1.7	1.13 H	164	61.50	5.10
5	11420.00	56.0 PK	74.0	-18.0	1.28 H	159	45.40	10.60
6	11420.00	43.2 AV	54.0	-10.8	1.28 H	159	32.60	10.60
7	#17130.00	61.0 PK	68.3	-7.3	1.00 H	140	42.10	18.90

ANTENNA POLARITY & TEST DISTANCE: VERTICAL AT 3 M

NO.	FREQ. (MHz)	EMISSION LEVEL (dBuV/m)	LIMIT (dBuV/m)	MARGIN (dB)	ANTENNA HEIGHT (m)	TABLE ANGLE (Degree)	RAW VALUE (dBuV)	CORRECTION FACTOR (dB/m)
1	#5470.00	66.1 PK	68.3	-2.2	1.22 V	189	61.50	4.60
2	*5710.00	114.6 PK			1.18 V	78	109.70	4.90
3	*5710.00	105.4 AV			1.18 V	78	100.50	4.90
4	#5865.00	68.1 PK	68.3	-0.2	1.05 V	158	63.00	5.10
5	11420.00	55.0 PK	74.0	-19.0	1.25 V	82	44.40	10.60
6	11420.00	42.3 AV	54.0	-11.7	1.25 V	82	31.70	10.60
7	#17130.00	58.8 PK	68.3	-9.5	1.18 V	117	39.90	18.90

REMARKS:

1. Emission Level(dBuV/m) = Raw Value(dBuV) + Correction Factor(dB/m)
2. Correction Factor(dB/m) = Antenna Factor(dB/m) + Cable Factor(dB) – Pre-Amplifier Factor(dB)
3. The other emission levels were very low against the limit.
4. Margin value = Emission Level – Limit value
5. " * ": Fundamental frequency.
6. " # ": The radiated frequency is out of the restricted band.



A D T

802.11ac (VHT80)

CHANNEL	TX Channel 58	DETECTOR FUNCTION	Peak (PK)
FREQUENCY RANGE	1GHz ~ 40GHz		Average (AV)

ANTENNA POLARITY & TEST DISTANCE: HORIZONTAL AT 3 M

NO.	FREQ. (MHz)	EMISSION LEVEL (dBuV/m)	LIMIT (dBuV/m)	MARGIN (dB)	ANTENNA HEIGHT (m)	TABLE ANGLE (Degree)	RAW VALUE (dBuV)	CORRECTION FACTOR (dB/m)
1	*5290.00	104.9 PK			1.05 H	359	100.60	4.30
2	*5290.00	94.2 AV			1.05 H	359	89.90	4.30
3	5374.00	61.7 PK	74.0	-12.3	1.04 H	345	57.10	4.60
4	5374.00	49.8 AV	54.0	-4.2	1.04 H	345	45.20	4.60
5	#5470.00	56.2 PK	68.3	-12.1	1.02 H	357	51.60	4.60
6	#5877.00	58.0 PK	68.3	-10.3	1.12 H	360	52.90	5.10
7	#10580.00	56.3 PK	68.3	-12.0	1.31 H	152	45.70	10.60
8	15870.00	60.8 PK	74.0	-13.2	1.05 H	142	45.90	14.90
9	15870.00	47.9 AV	54.0	-6.1	1.05 H	142	33.00	14.90

ANTENNA POLARITY & TEST DISTANCE: VERTICAL AT 3 M

NO.	FREQ. (MHz)	EMISSION LEVEL (dBuV/m)	LIMIT (dBuV/m)	MARGIN (dB)	ANTENNA HEIGHT (m)	TABLE ANGLE (Degree)	RAW VALUE (dBuV)	CORRECTION FACTOR (dB/m)
1	*5290.00	106.5 PK			1.06 V	156	102.20	4.30
2	*5290.00	96.1 AV			1.06 V	156	91.80	4.30
3	5374.00	65.2 PK	74.0	-8.8	1.04 V	154	60.60	4.60
4	5374.00	53.5 AV	54.0	-0.5	1.04 V	154	48.90	4.60
5	#5470.00	64.1 PK	68.3	-4.2	1.01 V	152	59.50	4.60
6	#5877.00	57.9 PK	68.3	-10.4	1.04 V	154	52.80	5.10
7	#10580.00	54.9 PK	68.3	-13.4	1.30 V	96	44.30	10.60
8	15870.00	58.6 PK	74.0	-15.4	1.23 V	122	43.70	14.90
9	15870.00	46.7 AV	54.0	-7.3	1.23 V	122	31.80	14.90

REMARKS:

1. Emission Level(dBuV/m) = Raw Value(dBuV) + Correction Factor(dB/m)
2. Correction Factor(dB/m) = Antenna Factor(dB/m) + Cable Factor(dB) – Pre-Amplifier Factor(dB)
3. The other emission levels were very low against the limit.
4. Margin value = Emission Level – Limit value
5. " * ": Fundamental frequency.
6. " # ": The radiated frequency is out of the restricted band.



A D T

CHANNEL	TX Channel 106	DETECTOR FUNCTION	Peak (PK)
FREQUENCY RANGE	1GHz ~ 40GHz		Average (AV)

ANTENNA POLARITY & TEST DISTANCE: HORIZONTAL AT 3 M

NO.	FREQ. (MHz)	EMISSION LEVEL (dBuV/m)	LIMIT (dBuV/m)	MARGIN (dB)	ANTENNA HEIGHT (m)	TABLE ANGLE (Degree)	RAW VALUE (dBuV)	CORRECTION FACTOR (dB/m)
1	5460.00	60.2 PK	74.0	-13.8	1.13 H	346	55.60	4.60
2	5460.00	48.0 AV	54.0	-6.0	1.13 H	346	43.40	4.60
3	#5470.00	62.1 PK	68.3	-6.2	1.13 H	345	57.50	4.60
4	*5530.00	101.4 PK			1.10 H	360	96.80	4.60
5	*5530.00	90.2 AV			1.10 H	360	85.60	4.60
6	11060.00	56.5 PK	74.0	-17.5	1.32 H	151	45.80	10.70
7	11060.00	43.7 AV	54.0	-10.3	1.32 H	151	33.00	10.70
8	#16590.00	60.3 PK	68.3	-8.0	1.01 H	144	43.20	17.10

ANTENNA POLARITY & TEST DISTANCE: VERTICAL AT 3 M

NO.	FREQ. (MHz)	EMISSION LEVEL (dBuV/m)	LIMIT (dBuV/m)	MARGIN (dB)	ANTENNA HEIGHT (m)	TABLE ANGLE (Degree)	RAW VALUE (dBuV)	CORRECTION FACTOR (dB/m)
1	5460.00	65.9 PK	74.0	-8.1	1.01 V	154	61.30	4.60
2	5460.00	50.0 AV	54.0	-4.0	1.01 V	154	45.40	4.60
3	#5470.00	68.1 PK	68.3	-0.2	1.01 V	154	63.50	4.60
4	*5530.00	103.1 PK			1.01 V	153	98.50	4.60
5	*5530.00	92.8 AV			1.01 V	153	88.20	4.60
6	11060.00	54.4 PK	74.0	-19.6	1.27 V	96	43.70	10.70
7	11060.00	42.1 AV	54.0	-11.9	1.27 V	96	31.40	10.70
8	#16590.00	58.6 PK	68.3	-9.7	1.27 V	132	41.50	17.10

REMARKS:

1. Emission Level(dBuV/m) = Raw Value(dBuV) + Correction Factor(dB/m)
2. Correction Factor(dB/m) = Antenna Factor(dB/m) + Cable Factor(dB) – Pre-Amplifier Factor(dB)
3. The other emission levels were very low against the limit.
4. Margin value = Emission Level – Limit value
5. " * ": Fundamental frequency.
6. " # ": The radiated frequency is out of the restricted band.



A D T

CHANNEL	TX Channel 138	DETECTOR FUNCTION	Peak (PK)
FREQUENCY RANGE	1GHz ~ 40GHz		Average (AV)

ANTENNA POLARITY & TEST DISTANCE: HORIZONTAL AT 3 M

NO.	FREQ. (MHz)	EMISSION LEVEL (dBuV/m)	LIMIT (dBuV/m)	MARGIN (dB)	ANTENNA HEIGHT (m)	TABLE ANGLE (Degree)	RAW VALUE (dBuV)	CORRECTION FACTOR (dB/m)
1	#5470.00	60.7 PK	68.3	-7.6	1.23 H	349	56.10	4.60
2	*5690.00	107.2 PK			1.15 H	355	102.20	5.00
3	*5690.00	96.5 AV			1.15 H	355	91.50	5.00
4	#5850.00	61.2 PK	68.3	-7.1	1.21 H	345	56.10	5.10
5	11380.00	56.7 PK	74.0	-17.3	1.31 H	143	46.00	10.70
6	11380.00	44.2 AV	54.0	-9.8	1.31 H	143	33.50	10.70
7	#17070.00	60.2 PK	68.3	-8.1	1.07 H	160	41.70	18.50

ANTENNA POLARITY & TEST DISTANCE: VERTICAL AT 3 M

NO.	FREQ. (MHz)	EMISSION LEVEL (dBuV/m)	LIMIT (dBuV/m)	MARGIN (dB)	ANTENNA HEIGHT (m)	TABLE ANGLE (Degree)	RAW VALUE (dBuV)	CORRECTION FACTOR (dB/m)
1	#5470.00	65.8 PK	68.3	-2.5	1.01 V	152	61.20	4.60
2	*5690.00	109.5 PK			1.07 V	154	104.50	5.00
3	*5690.00	98.8 AV			1.07 V	154	93.80	5.00
4	#5850.00	67.9 PK	68.3	-0.4	1.00 V	94	62.80	5.10
5	11380.00	54.9 PK	74.0	-19.1	1.28 V	87	44.20	10.70
6	11380.00	42.3 AV	54.0	-11.7	1.28 V	87	31.60	10.70
7	#17070.00	57.9 PK	68.3	-10.4	1.22 V	119	39.40	18.50

REMARKS:

1. Emission Level(dBuV/m) = Raw Value(dBuV) + Correction Factor(dB/m)
2. Correction Factor(dB/m) = Antenna Factor(dB/m) + Cable Factor(dB) – Pre-Amplifier Factor(dB)
3. The other emission levels were very low against the limit.
4. Margin value = Emission Level – Limit value
5. " * ": Fundamental frequency.
6. " # ": The radiated frequency is out of the restricted band.



A D T

STBC_MODE

ABOVE 1GHz DATA

802.11ac (VHT20)

CHANNEL	TX Channel 52	DETECTOR FUNCTION	Peak (PK)
FREQUENCY RANGE	1GHz ~ 40GHz		Average (AV)

ANTENNA POLARITY & TEST DISTANCE: HORIZONTAL AT 3 M

NO.	FREQ. (MHz)	EMISSION LEVEL (dBuV/m)	LIMIT (dBuV/m)	MARGIN (dB)	ANTENNA HEIGHT (m)	TABLE ANGLE (Degree)	RAW VALUE (dBuV)	CORRECTION FACTOR (dB/m)
1	*5260.00	103.0 PK			1.20 H	15	98.60	4.40
2	*5260.00	92.0 AV			1.20 H	15	87.60	4.40
3	5422.00	58.4 PK	74.0	-15.6	1.02 H	185	53.80	4.60
4	5422.00	46.2 AV	54.0	-7.8	1.02 H	185	41.60	4.60
5	#10520.00	56.9 PK	68.3	-11.4	1.19 H	135	46.50	10.40
6	15780.00	60.1 PK	74.0	-13.9	1.16 H	134	45.40	14.70
7	15780.00	47.8 AV	54.0	-6.2	1.16 H	134	33.10	14.70

ANTENNA POLARITY & TEST DISTANCE: VERTICAL AT 3 M

NO.	FREQ. (MHz)	EMISSION LEVEL (dBuV/m)	LIMIT (dBuV/m)	MARGIN (dB)	ANTENNA HEIGHT (m)	TABLE ANGLE (Degree)	RAW VALUE (dBuV)	CORRECTION FACTOR (dB/m)
1	*5260.00	106.8 PK			1.16 V	171	102.40	4.40
2	*5260.00	97.4 AV			1.16 V	171	93.00	4.40
3	5422.00	63.8 PK	74.0	-10.2	1.02 V	152	59.20	4.60
4	5422.00	53.6 AV	54.0	-0.4	1.02 V	152	49.00	4.60
5	#10520.00	54.7 PK	68.3	-13.6	1.08 V	88	44.30	10.40
6	15780.00	57.4 PK	74.0	-16.6	1.29 V	80	42.70	14.70
7	15780.00	46.2 AV	54.0	-7.8	1.29 V	80	31.50	14.70

REMARKS:

1. Emission Level(dBuV/m) = Raw Value(dBuV) + Correction Factor(dB/m)
2. Correction Factor(dB/m) = Antenna Factor(dB/m) + Cable Factor(dB) – Pre-Amplifier Factor(dB)
3. The other emission levels were very low against the limit.
4. Margin value = Emission Level – Limit value
5. " * ": Fundamental frequency.
6. " # ": The radiated frequency is out of the restricted band.



A D T

CHANNEL	TX Channel 60	DETECTOR FUNCTION	Peak (PK)
FREQUENCY RANGE	1GHz ~ 40GHz		Average (AV)

ANTENNA POLARITY & TEST DISTANCE: HORIZONTAL AT 3 M

NO.	FREQ. (MHz)	EMISSION LEVEL (dBuV/m)	LIMIT (dBuV/m)	MARGIN (dB)	ANTENNA HEIGHT (m)	TABLE ANGLE (Degree)	RAW VALUE (dBuV)	CORRECTION FACTOR (dB/m)
1	*5300.00	103.8 PK			1.20 H	8	99.40	4.40
2	*5300.00	92.5 AV			1.20 H	8	88.10	4.40
3	5378.00	61.4 PK	74.0	-12.6	1.05 H	345	56.70	4.70
4	5378.00	49.7 AV	54.0	-4.3	1.05 H	345	45.00	4.70
5	5458.00	61.8 PK	74.0	-12.2	1.05 H	311	57.20	4.60
6	5458.00	50.8 AV	54.0	-3.2	1.05 H	311	46.20	4.60
7	#5470.00	57.2 PK	68.3	-11.1	1.05 H	12	52.60	4.60
8	10600.00	56.9 PK	74.0	-17.1	1.24 H	123	46.30	10.60
9	10600.00	43.7 AV	54.0	-10.3	1.24 H	123	33.10	10.60
10	15900.00	59.5 PK	74.0	-14.5	1.15 H	129	44.40	15.10
11	15900.00	47.3 AV	54.0	-6.7	1.15 H	129	32.20	15.10

ANTENNA POLARITY & TEST DISTANCE: VERTICAL AT 3 M

NO.	FREQ. (MHz)	EMISSION LEVEL (dBuV/m)	LIMIT (dBuV/m)	MARGIN (dB)	ANTENNA HEIGHT (m)	TABLE ANGLE (Degree)	RAW VALUE (dBuV)	CORRECTION FACTOR (dB/m)
1	*5300.00	106.5 PK			1.19 V	170	102.10	4.40
2	*5300.00	97.1 AV			1.19 V	170	92.70	4.40
3	5378.00	64.8 PK	74.0	-9.2	1.06 V	146	60.10	4.70
4	5378.00	53.8 AV	54.0	-0.2	1.06 V	146	49.10	4.70
5	5458.00	63.7 PK	74.0	-10.3	1.06 V	155	59.10	4.60
6	5458.00	53.3 AV	54.0	-0.7	1.06 V	155	48.70	4.60
7	#5470.00	64.2 PK	68.3	-4.1	1.06 V	146	59.60	4.60
8	10600.00	54.7 PK	74.0	-19.3	1.12 V	100	44.10	10.60
9	10600.00	42.2 AV	54.0	-11.8	1.12 V	100	31.60	10.60
10	15900.00	57.6 PK	74.0	-16.4	1.25 V	81	42.50	15.10
11	15900.00	46.6 AV	54.0	-7.4	1.25 V	81	31.50	15.10

REMARKS:

1. Emission Level(dBuV/m) = Raw Value(dBuV) + Correction Factor(dB/m)
2. Correction Factor(dB/m) = Antenna Factor(dB/m) + Cable Factor(dB) – Pre-Amplifier Factor(dB)
3. The other emission levels were very low against the limit.
4. Margin value = Emission Level – Limit value
5. " * ": Fundamental frequency.
6. " # ": The radiated frequency is out of the restricted band.



A D T

CHANNEL	TX Channel 64	DETECTOR FUNCTION	Peak (PK)
FREQUENCY RANGE	1GHz ~ 40GHz		Average (AV)

ANTENNA POLARITY & TEST DISTANCE: HORIZONTAL AT 3 M

NO.	FREQ. (MHz)	EMISSION LEVEL (dBuV/m)	LIMIT (dBuV/m)	MARGIN (dB)	ANTENNA HEIGHT (m)	TABLE ANGLE (Degree)	RAW VALUE (dBuV)	CORRECTION FACTOR (dB/m)
1	*5320.00	103.1 PK			1.18 H	25	98.70	4.40
2	*5320.00	91.9 AV			1.18 H	25	87.50	4.40
3	5400.00	62.4 PK	74.0	-11.6	1.05 H	13	57.70	4.70
4	5400.00	51.4 AV	54.0	-2.6	1.05 H	13	46.70	4.70
5	10640.00	57.3 PK	74.0	-16.7	1.19 H	121	46.70	10.60
6	10640.00	44.0 AV	54.0	-10.0	1.19 H	121	33.40	10.60
7	15960.00	59.5 PK	74.0	-14.5	1.15 H	144	44.60	14.90
8	15960.00	47.2 AV	54.0	-6.8	1.15 H	144	32.30	14.90

ANTENNA POLARITY & TEST DISTANCE: VERTICAL AT 3 M

NO.	FREQ. (MHz)	EMISSION LEVEL (dBuV/m)	LIMIT (dBuV/m)	MARGIN (dB)	ANTENNA HEIGHT (m)	TABLE ANGLE (Degree)	RAW VALUE (dBuV)	CORRECTION FACTOR (dB/m)
1	*5320.00	107.2 PK			1.17 V	177	102.80	4.40
2	*5320.00	97.6 AV			1.17 V	177	93.20	4.40
3	5400.00	63.2 PK	74.0	-10.8	1.08 V	146	58.50	4.70
4	5400.00	53.8 AV	54.0	-0.2	1.08 V	146	49.10	4.70
5	10640.00	54.8 PK	74.0	-19.2	1.17 V	89	44.20	10.60
6	10640.00	42.0 AV	54.0	-12.0	1.17 V	89	31.40	10.60
7	15960.00	57.1 PK	74.0	-16.9	1.22 V	92	42.20	14.90
8	15960.00	46.1 AV	54.0	-7.9	1.22 V	92	31.20	14.90

REMARKS:

1. Emission Level(dBuV/m) = Raw Value(dBuV) + Correction Factor(dB/m)
2. Correction Factor(dB/m) = Antenna Factor(dB/m) + Cable Factor(dB) – Pre-Amplifier Factor(dB)
3. The other emission levels were very low against the limit.
4. Margin value = Emission Level – Limit value
5. " * ": Fundamental frequency.



A D T

CHANNEL	TX Channel 100	DETECTOR FUNCTION	Peak (PK)
FREQUENCY RANGE	1GHz ~ 40GHz		Average (AV)

ANTENNA POLARITY & TEST DISTANCE: HORIZONTAL AT 3 M

NO.	FREQ. (MHz)	EMISSION LEVEL (dBuV/m)	LIMIT (dBuV/m)	MARGIN (dB)	ANTENNA HEIGHT (m)	TABLE ANGLE (Degree)	RAW VALUE (dBuV)	CORRECTION FACTOR (dB/m)
1	5422.00	64.9 PK	74.0	-9.1	1.04 H	182	60.30	4.60
2	5422.00	53.1 AV	54.0	-0.9	1.04 H	182	48.50	4.60
3	*5500.00	103.7 PK			1.12 H	8	99.10	4.60
4	*5500.00	93.2 AV			1.12 H	8	88.60	4.60
5	11000.00	56.8 PK	74.0	-17.2	1.14 H	136	46.00	10.80
6	11000.00	43.5 AV	54.0	-10.5	1.14 H	136	32.70	10.80
7	#16500.00	59.1 PK	68.3	-9.2	1.17 H	128	42.10	17.00

ANTENNA POLARITY & TEST DISTANCE: VERTICAL AT 3 M

NO.	FREQ. (MHz)	EMISSION LEVEL (dBuV/m)	LIMIT (dBuV/m)	MARGIN (dB)	ANTENNA HEIGHT (m)	TABLE ANGLE (Degree)	RAW VALUE (dBuV)	CORRECTION FACTOR (dB/m)
1	5422.00	63.2 PK	74.0	-10.8	1.06 V	144	58.60	4.60
2	5422.00	53.6 AV	54.0	-0.4	1.06 V	144	49.00	4.60
3	#5470.00	56.4 PK	68.3	-11.9	1.06 V	144	51.80	4.60
4	*5500.00	108.8 PK			1.05 V	146	104.20	4.60
5	*5500.00	98.7 AV			1.05 V	146	94.10	4.60
6	11000.00	54.8 PK	74.0	-19.2	1.15 V	96	44.00	10.80
7	11000.00	42.1 AV	54.0	-11.9	1.15 V	96	31.30	10.80
8	#16500.00	56.9 PK	68.3	-11.4	1.21 V	86	39.90	17.00

REMARKS:

1. Emission Level(dBuV/m) = Raw Value(dBuV) + Correction Factor(dB/m)
2. Correction Factor(dB/m) = Antenna Factor(dB/m) + Cable Factor(dB) – Pre-Amplifier Factor(dB)
3. The other emission levels were very low against the limit.
4. Margin value = Emission Level – Limit value
5. " * " : Fundamental frequency.
6. " # " : The radiated frequency is out of the restricted band.



A D T

CHANNEL	TX Channel 116	DETECTOR FUNCTION	Peak (PK)
FREQUENCY RANGE	1GHz ~ 40GHz		Average (AV)

ANTENNA POLARITY & TEST DISTANCE: HORIZONTAL AT 3 M

NO.	FREQ. (MHz)	EMISSION LEVEL (dBuV/m)	LIMIT (dBuV/m)	MARGIN (dB)	ANTENNA HEIGHT (m)	TABLE ANGLE (Degree)	RAW VALUE (dBuV)	CORRECTION FACTOR (dB/m)
1	5421.00	58.5 PK	74.0	-15.5	1.04 H	151	53.90	4.60
2	5421.00	47.8 AV	54.0	-6.2	1.04 H	151	43.20	4.60
3	*5580.00	104.5 PK			1.06 H	16	99.60	4.90
4	*5580.00	94.8 AV			1.06 H	16	89.90	4.90
5	#5740.00	61.2 PK	68.3	-7.1	1.05 H	174	56.30	4.90
6	11160.00	56.6 PK	74.0	-17.4	1.14 H	149	45.90	10.70
7	11160.00	43.3 AV	54.0	-10.7	1.14 H	149	32.60	10.70
8	#16740.00	59.4 PK	68.3	-8.9	1.18 H	124	41.50	17.90

ANTENNA POLARITY & TEST DISTANCE: VERTICAL AT 3 M

NO.	FREQ. (MHz)	EMISSION LEVEL (dBuV/m)	LIMIT (dBuV/m)	MARGIN (dB)	ANTENNA HEIGHT (m)	TABLE ANGLE (Degree)	RAW VALUE (dBuV)	CORRECTION FACTOR (dB/m)
1	5421.00	64.1 PK	74.0	-9.9	1.06 V	147	59.50	4.60
2	5421.00	53.0 AV	54.0	-1.0	1.06 V	147	48.40	4.60
3	*5580.00	108.7 PK			1.01 V	131	103.80	4.90
4	*5580.00	98.9 AV			1.01 V	131	94.00	4.90
5	#5740.00	67.8 PK	68.3	-0.5	1.00 V	143	62.90	4.90
6	11160.00	55.3 PK	74.0	-18.7	1.20 V	107	44.60	10.70
7	11160.00	42.5 AV	54.0	-11.5	1.20 V	107	31.80	10.70
8	#16740.00	56.9 PK	68.3	-11.4	1.20 V	85	39.00	17.90

REMARKS:

1. Emission Level(dBuV/m) = Raw Value(dBuV) + Correction Factor(dB/m)
2. Correction Factor(dB/m) = Antenna Factor(dB/m) + Cable Factor(dB) – Pre-Amplifier Factor(dB)
3. The other emission levels were very low against the limit.
4. Margin value = Emission Level – Limit value
5. " * ": Fundamental frequency.
6. " # ": The radiated frequency is out of the restricted band.



A D T

CHANNEL	TX Channel 132	DETECTOR FUNCTION	Peak (PK)
FREQUENCY RANGE	1GHz ~ 40GHz		Average (AV)

ANTENNA POLARITY & TEST DISTANCE: HORIZONTAL AT 3 M

NO.	FREQ. (MHz)	EMISSION LEVEL (dBuV/m)	LIMIT (dBuV/m)	MARGIN (dB)	ANTENNA HEIGHT (m)	TABLE ANGLE (Degree)	RAW VALUE (dBuV)	CORRECTION FACTOR (dB/m)
1	*5660.00	104.0 PK			1.07 H	13	99.10	4.90
2	*5660.00	94.6 AV			1.07 H	13	89.70	4.90
3	#5738.00	64.3 PK	68.3	-4.0	1.21 H	12	59.40	4.90
4	#5818.00	61.2 PK	68.3	-7.1	1.19 H	23	56.20	5.00
5	11320.00	56.4 PK	74.0	-17.6	1.20 H	161	45.60	10.80
6	11320.00	43.2 AV	54.0	-10.8	1.20 H	161	32.40	10.80
7	#16980.00	59.6 PK	68.3	-8.7	1.17 H	110	41.20	18.40

ANTENNA POLARITY & TEST DISTANCE: VERTICAL AT 3 M

NO.	FREQ. (MHz)	EMISSION LEVEL (dBuV/m)	LIMIT (dBuV/m)	MARGIN (dB)	ANTENNA HEIGHT (m)	TABLE ANGLE (Degree)	RAW VALUE (dBuV)	CORRECTION FACTOR (dB/m)
1	*5660.00	108.3 PK			1.02 V	133	103.40	4.90
2	*5660.00	98.4 AV			1.02 V	133	93.50	4.90
3	#5738.00	66.1 PK	68.3	-2.2	1.00 V	141	61.20	4.90
4	#5818.00	67.9 PK	68.3	-0.4	1.00 V	141	62.90	5.00
5	11320.00	55.2 PK	74.0	-18.8	1.16 V	93	44.40	10.80
6	11320.00	42.2 AV	54.0	-11.8	1.16 V	93	31.40	10.80
7	#16980.00	56.6 PK	68.3	-11.7	1.26 V	99	38.20	18.40

REMARKS:

1. Emission Level(dBuV/m) = Raw Value(dBuV) + Correction Factor(dB/m)
2. Correction Factor(dB/m) = Antenna Factor(dB/m) + Cable Factor(dB) – Pre-Amplifier Factor(dB)
3. The other emission levels were very low against the limit.
4. Margin value = Emission Level – Limit value
5. " * ": Fundamental frequency.
6. " # ": The radiated frequency is out of the restricted band.



A D T

CHANNEL	TX Channel 140	DETECTOR FUNCTION	Peak (PK)
FREQUENCY RANGE	1GHz ~ 40GHz		Average (AV)

ANTENNA POLARITY & TEST DISTANCE: HORIZONTAL AT 3 M

NO.	FREQ. (MHz)	EMISSION LEVEL (dBuV/m)	LIMIT (dBuV/m)	MARGIN (dB)	ANTENNA HEIGHT (m)	TABLE ANGLE (Degree)	RAW VALUE (dBuV)	CORRECTION FACTOR (dB/m)
1	*5700.00	104.4 PK			1.12 H	12	99.50	4.90
2	*5700.00	94.1 AV			1.12 H	12	89.20	4.90
3	#5780.00	62.3 PK	68.3	-6.0	1.20 H	345	57.40	4.90
4	#5858.00	58.9 PK	68.3	-9.4	1.23 H	356	53.80	5.10
5	11400.00	56.6 PK	74.0	-17.4	1.16 H	163	45.90	10.70
6	11400.00	43.6 AV	54.0	-10.4	1.16 H	163	32.90	10.70
7	#17100.00	59.9 PK	68.3	-8.4	1.16 H	99	41.30	18.60

ANTENNA POLARITY & TEST DISTANCE: VERTICAL AT 3 M

NO.	FREQ. (MHz)	EMISSION LEVEL (dBuV/m)	LIMIT (dBuV/m)	MARGIN (dB)	ANTENNA HEIGHT (m)	TABLE ANGLE (Degree)	RAW VALUE (dBuV)	CORRECTION FACTOR (dB/m)
1	*5700.00	107.7 PK			1.00 V	115	102.80	4.90
2	*5700.00	98.1 AV			1.00 V	115	93.20	4.90
3	#5780.00	64.9 PK	68.3	-3.4	1.00 V	145	60.00	4.90
4	#5858.00	67.9 PK	68.3	-0.4	1.00 V	145	62.80	5.10
5	11400.00	55.2 PK	74.0	-18.8	1.15 V	94	44.50	10.70
6	11400.00	42.3 AV	54.0	-11.7	1.15 V	94	31.60	10.70
7	#17100.00	56.9 PK	68.3	-11.4	1.28 V	94	38.30	18.60

REMARKS:

1. Emission Level(dBuV/m) = Raw Value(dBuV) + Correction Factor(dB/m)
2. Correction Factor(dB/m) = Antenna Factor(dB/m) + Cable Factor(dB) – Pre-Amplifier Factor(dB)
3. The other emission levels were very low against the limit.
4. Margin value = Emission Level – Limit value
5. " * ": Fundamental frequency.
6. " # ": The radiated frequency is out of the restricted band.



A D T

CHANNEL	TX Channel 144	DETECTOR FUNCTION	Peak (PK)
FREQUENCY RANGE	1GHz ~ 40GHz		Average (AV)

ANTENNA POLARITY & TEST DISTANCE: HORIZONTAL AT 3 M

NO.	FREQ. (MHz)	EMISSION LEVEL (dBuV/m)	LIMIT (dBuV/m)	MARGIN (dB)	ANTENNA HEIGHT (m)	TABLE ANGLE (Degree)	RAW VALUE (dBuV)	CORRECTION FACTOR (dB/m)
1	*5720.00	108.8 PK			1.24 H	350	103.90	4.90
2	*5720.00	99.1 AV			1.24 H	350	94.20	4.90
3	#5840.00	56.4 PK	68.3	-11.9	1.08 H	175	51.30	5.10
4	#5881.00	59.8 PK	68.3	-8.5	1.09 H	188	54.70	5.10
5	11440.00	56.9 PK	74.0	-17.1	1.13 H	173	46.30	10.60
6	11440.00	43.7 AV	54.0	-10.3	1.13 H	173	33.10	10.60
7	#17160.00	59.5 PK	68.3	-8.8	1.18 H	106	40.40	19.10

ANTENNA POLARITY & TEST DISTANCE: VERTICAL AT 3 M

NO.	FREQ. (MHz)	EMISSION LEVEL (dBuV/m)	LIMIT (dBuV/m)	MARGIN (dB)	ANTENNA HEIGHT (m)	TABLE ANGLE (Degree)	RAW VALUE (dBuV)	CORRECTION FACTOR (dB/m)
1	*5720.00	112.8 PK			1.00 V	145	107.90	4.90
2	*5720.00	102.1 AV			1.00 V	145	97.20	4.90
3	#5840.00	61.3 PK	68.3	-7.0	1.07 V	152	56.20	5.10
4	#5881.00	68.1 PK	68.3	-0.2	1.07 V	152	63.00	5.10
5	11440.00	55.3 PK	74.0	-18.7	1.11 V	79	44.70	10.60
6	11440.00	42.4 AV	54.0	-11.6	1.11 V	79	31.80	10.60
7	#17160.00	57.0 PK	68.3	-11.3	1.30 V	104	37.90	19.10

REMARKS:

1. Emission Level(dBuV/m) = Raw Value(dBuV) + Correction Factor(dB/m)
2. Correction Factor(dB/m) = Antenna Factor(dB/m) + Cable Factor(dB) – Pre-Amplifier Factor(dB)
3. The other emission levels were very low against the limit.
4. Margin value = Emission Level – Limit value
5. " * ": Fundamental frequency.
6. " # ": The radiated frequency is out of the restricted band.



A D T

802.11ac (VHT40)

CHANNEL	TX Channel 54	DETECTOR FUNCTION	Peak (PK)
FREQUENCY RANGE	1GHz ~ 40GHz		Average (AV)

ANTENNA POLARITY & TEST DISTANCE: HORIZONTAL AT 3 M

NO.	FREQ. (MHz)	EMISSION LEVEL (dBuV/m)	LIMIT (dBuV/m)	MARGIN (dB)	ANTENNA HEIGHT (m)	TABLE ANGLE (Degree)	RAW VALUE (dBuV)	CORRECTION FACTOR (dB/m)
1	*5270.00	105.4 PK			1.07 H	140	101.10	4.30
2	*5270.00	94.8 AV			1.07 H	140	90.50	4.30
3	5354.00	61.7 PK	74.0	-12.3	1.10 H	181	57.30	4.40
4	5354.00	50.7 AV	54.0	-3.3	1.10 H	181	46.30	4.40
5	5425.00	57.9 PK	74.0	-16.1	1.28 H	151	53.30	4.60
6	5425.00	46.9 AV	54.0	-7.1	1.28 H	151	42.30	4.60
7	#10540.00	56.8 PK	68.3	-11.5	1.12 H	172	46.40	10.40
8	15810.00	59.2 PK	74.0	-14.8	1.20 H	113	44.40	14.80
9	15810.00	47.0 AV	54.0	-7.0	1.20 H	113	32.20	14.80

ANTENNA POLARITY & TEST DISTANCE: VERTICAL AT 3 M

NO.	FREQ. (MHz)	EMISSION LEVEL (dBuV/m)	LIMIT (dBuV/m)	MARGIN (dB)	ANTENNA HEIGHT (m)	TABLE ANGLE (Degree)	RAW VALUE (dBuV)	CORRECTION FACTOR (dB/m)
1	*5270.00	107.5 PK			1.08 V	151	103.20	4.30
2	*5270.00	97.2 AV			1.08 V	151	92.90	4.30
3	5354.00	64.2 PK	74.0	-9.8	1.18 V	157	59.80	4.40
4	5354.00	53.1 AV	54.0	-0.9	1.18 V	157	48.70	4.40
5	5425.00	64.8 PK	74.0	-9.2	1.16 V	162	60.20	4.60
6	5425.00	53.8 AV	54.0	-0.2	1.16 V	162	49.20	4.60
7	#10540.00	55.4 PK	68.3	-12.9	1.14 V	88	45.00	10.40
8	15810.00	57.2 PK	74.0	-16.8	1.25 V	103	42.40	14.80
9	15810.00	46.1 AV	54.0	-7.9	1.25 V	103	31.30	14.80

REMARKS:

1. Emission Level(dBuV/m) = Raw Value(dBuV) + Correction Factor(dB/m)
2. Correction Factor(dB/m) = Antenna Factor(dB/m) + Cable Factor(dB) – Pre-Amplifier Factor(dB)
3. The other emission levels were very low against the limit.
4. Margin value = Emission Level – Limit value
5. " * ": Fundamental frequency.
6. " # ": The radiated frequency is out of the restricted band.



A D T

CHANNEL	TX Channel 62	DETECTOR FUNCTION	Peak (PK)
FREQUENCY RANGE	1GHz ~ 40GHz		Average (AV)

ANTENNA POLARITY & TEST DISTANCE: HORIZONTAL AT 3 M								
NO.	FREQ. (MHz)	EMISSION LEVEL (dBuV/m)	LIMIT (dBuV/m)	MARGIN (dB)	ANTENNA HEIGHT (m)	TABLE ANGLE (Degree)	RAW VALUE (dBuV)	CORRECTION FACTOR (dB/m)
1	*5310.00	104.5 PK			1.04 H	112	100.10	4.40
2	*5310.00	94.6 AV			1.04 H	112	90.20	4.40
3	5394.00	67.9 PK	74.0	-6.1	1.07 H	167	63.20	4.70
4	5394.00	51.8 AV	54.0	-2.2	1.07 H	167	47.10	4.70
5	#5470.00	58.7 PK	68.3	-9.6	1.00 H	167	54.10	4.60
6	10620.00	56.5 PK	74.0	-17.5	1.16 H	161	45.90	10.60
7	10620.00	43.5 AV	54.0	-10.5	1.16 H	161	32.90	10.60
8	15930.00	59.3 PK	74.0	-14.7	1.25 H	120	44.40	14.90
9	15930.00	47.1 AV	54.0	-6.9	1.25 H	120	32.20	14.90

ANTENNA POLARITY & TEST DISTANCE: VERTICAL AT 3 M								
NO.	FREQ. (MHz)	EMISSION LEVEL (dBuV/m)	LIMIT (dBuV/m)	MARGIN (dB)	ANTENNA HEIGHT (m)	TABLE ANGLE (Degree)	RAW VALUE (dBuV)	CORRECTION FACTOR (dB/m)
1	*5310.00	108.2 PK			1.09 V	150	103.80	4.40
2	*5310.00	98.7 AV			1.09 V	150	94.30	4.40
3	5394.00	64.8 PK	74.0	-9.2	1.07 V	148	60.10	4.70
4	5394.00	53.8 AV	54.0	-0.2	1.07 V	148	49.10	4.70
5	5460.00	62.4 PK	74.0	-11.6	1.04 V	156	57.80	4.60
6	5460.00	52.1 AV	54.0	-1.9	1.04 V	156	47.50	4.60
7	#5470.00	63.9 PK	68.3	-4.4	1.04 V	156	59.30	4.60
8	10620.00	55.6 PK	74.0	-18.4	1.10 V	75	45.00	10.60
9	10620.00	43.0 AV	54.0	-11.0	1.10 V	75	32.40	10.60
10	15930.00	57.3 PK	74.0	-16.7	1.19 V	87	42.40	14.90
11	15930.00	46.1 AV	54.0	-7.9	1.19 V	87	31.20	14.90

REMARKS:

1. Emission Level(dBuV/m) = Raw Value(dBuV) + Correction Factor(dB/m)
2. Correction Factor(dB/m) = Antenna Factor(dB/m) + Cable Factor(dB) – Pre-Amplifier Factor(dB)
3. The other emission levels were very low against the limit.
4. Margin value = Emission Level – Limit value
5. " * ": Fundamental frequency.
6. " # ": The radiated frequency is out of the restricted band.



A D T

CHANNEL	TX Channel 102	DETECTOR FUNCTION	Peak (PK)
FREQUENCY RANGE	1GHz ~ 40GHz		Average (AV)

ANTENNA POLARITY & TEST DISTANCE: HORIZONTAL AT 3 M

NO.	FREQ. (MHz)	EMISSION LEVEL (dBuV/m)	LIMIT (dBuV/m)	MARGIN (dB)	ANTENNA HEIGHT (m)	TABLE ANGLE (Degree)	RAW VALUE (dBuV)	CORRECTION FACTOR (dB/m)
1	5425.00	65.6 PK	74.0	-8.4	1.15 H	172	61.00	4.60
2	5425.00	50.6 AV	54.0	-3.4	1.15 H	172	46.00	4.60
3	#5470.00	67.0 PK	68.3	-1.3	1.17 H	158	62.40	4.60
4	*5510.00	105.2 PK			1.10 H	129	100.60	4.60
5	*5510.00	96.7 AV			1.10 H	129	92.10	4.60
6	11020.00	56.6 PK	74.0	-17.4	1.20 H	157	45.80	10.80
7	11020.00	43.3 AV	54.0	-10.7	1.20 H	157	32.50	10.80
8	#16530.00	59.9 PK	68.3	-8.4	1.21 H	130	42.80	17.10

ANTENNA POLARITY & TEST DISTANCE: VERTICAL AT 3 M

NO.	FREQ. (MHz)	EMISSION LEVEL (dBuV/m)	LIMIT (dBuV/m)	MARGIN (dB)	ANTENNA HEIGHT (m)	TABLE ANGLE (Degree)	RAW VALUE (dBuV)	CORRECTION FACTOR (dB/m)
1	5425.00	64.9 PK	74.0	-9.1	1.07 V	145	60.30	4.60
2	5425.00	51.8 AV	54.0	-2.2	1.07 V	145	47.20	4.60
3	#5470.00	68.1 PK	68.3	-0.2	1.06 V	145	63.50	4.60
4	*5510.00	107.8 PK			1.09 V	149	103.20	4.60
5	*5510.00	99.1 AV			1.09 V	149	94.50	4.60
6	11020.00	55.9 PK	74.0	-18.1	1.15 V	71	45.10	10.80
7	11020.00	43.0 AV	54.0	-11.0	1.15 V	71	32.20	10.80
8	#16530.00	57.4 PK	68.3	-10.9	1.24 V	96	40.30	17.10

REMARKS:

1. Emission Level(dBuV/m) = Raw Value(dBuV) + Correction Factor(dB/m)
2. Correction Factor(dB/m) = Antenna Factor(dB/m) + Cable Factor(dB) – Pre-Amplifier Factor(dB)
3. The other emission levels were very low against the limit.
4. Margin value = Emission Level – Limit value
5. " * ": Fundamental frequency.
6. " # ": The radiated frequency is out of the restricted band.



A D T

CHANNEL	TX Channel 110	DETECTOR FUNCTION	Peak (PK)
FREQUENCY RANGE	1GHz ~ 40GHz		Average (AV)

ANTENNA POLARITY & TEST DISTANCE: HORIZONTAL AT 3 M								
NO.	FREQ. (MHz)	EMISSION LEVEL (dBuV/m)	LIMIT (dBuV/m)	MARGIN (dB)	ANTENNA HEIGHT (m)	TABLE ANGLE (Degree)	RAW VALUE (dBuV)	CORRECTION FACTOR (dB/m)
1	5460.00	65.9 PK	74.0	-8.1	1.23 H	181	61.30	4.60
2	5460.00	51.9 AV	54.0	-2.1	1.23 H	181	47.30	4.60
3	#5470.00	66.4 PK	68.3	-1.9	1.08 H	173	61.80	4.60
4	*5550.00	107.8 PK			1.19 H	164	103.10	4.70
5	*5550.00	96.6 AV			1.19 H	164	91.90	4.70
6	#5725.00	62.3 PK	68.3	-6.0	1.13 H	167	57.40	4.90
7	11100.00	56.9 PK	74.0	-17.1	1.18 H	164	46.20	10.70
8	11100.00	43.3 AV	54.0	-10.7	1.18 H	164	32.60	10.70
9	#16650.00	60.1 PK	68.3	-8.2	1.25 H	118	42.60	17.50

ANTENNA POLARITY & TEST DISTANCE: VERTICAL AT 3 M								
NO.	FREQ. (MHz)	EMISSION LEVEL (dBuV/m)	LIMIT (dBuV/m)	MARGIN (dB)	ANTENNA HEIGHT (m)	TABLE ANGLE (Degree)	RAW VALUE (dBuV)	CORRECTION FACTOR (dB/m)
1	5460.00	65.1 PK	74.0	-8.9	1.05 V	154	60.50	4.60
2	5460.00	52.2 AV	54.0	-1.8	1.05 V	154	47.60	4.60
3	#5470.00	67.9 PK	68.3	-0.4	1.05 V	154	63.30	4.60
4	*5550.00	109.2 PK			1.03 V	148	104.50	4.70
5	*5550.00	98.2 AV			1.03 V	148	93.50	4.70
6	#5725.00	64.2 PK	68.3	-4.1	1.00 V	145	59.30	4.90
7	11100.00	55.8 PK	74.0	-18.2	1.17 V	66	45.10	10.70
8	11100.00	42.7 AV	54.0	-11.3	1.17 V	66	32.00	10.70
9	#16650.00	57.5 PK	68.3	-10.8	1.25 V	106	40.00	17.50

REMARKS:

1. Emission Level(dBuV/m) = Raw Value(dBuV) + Correction Factor(dB/m)
2. Correction Factor(dB/m) = Antenna Factor(dB/m) + Cable Factor(dB) – Pre-Amplifier Factor(dB)
3. The other emission levels were very low against the limit.
4. Margin value = Emission Level – Limit value
5. " * " : Fundamental frequency.
6. " # " : The radiated frequency is out of the restricted band.



A D T

CHANNEL	TX Channel 134	DETECTOR FUNCTION	Peak (PK)
FREQUENCY RANGE	1GHz ~ 40GHz		Average (AV)

ANTENNA POLARITY & TEST DISTANCE: HORIZONTAL AT 3 M

NO.	FREQ. (MHz)	EMISSION LEVEL (dBuV/m)	LIMIT (dBuV/m)	MARGIN (dB)	ANTENNA HEIGHT (m)	TABLE ANGLE (Degree)	RAW VALUE (dBuV)	CORRECTION FACTOR (dB/m)
1	*5670.00	107.2 PK			1.17 H	173	102.30	4.90
2	*5670.00	96.0 AV			1.17 H	173	91.10	4.90
3	#5733.00	67.6 PK	68.3	-0.7	1.15 H	181	62.70	4.90
4	#5834.00	59.1 PK	68.3	-9.2	1.12 H	180	54.00	5.10
5	11340.00	56.6 PK	74.0	-17.4	1.14 H	169	45.80	10.80
6	11340.00	42.9 AV	54.0	-11.1	1.14 H	169	32.10	10.80
7	#17010.00	60.1 PK	68.3	-8.2	1.26 H	113	41.70	18.40

ANTENNA POLARITY & TEST DISTANCE: VERTICAL AT 3 M

NO.	FREQ. (MHz)	EMISSION LEVEL (dBuV/m)	LIMIT (dBuV/m)	MARGIN (dB)	ANTENNA HEIGHT (m)	TABLE ANGLE (Degree)	RAW VALUE (dBuV)	CORRECTION FACTOR (dB/m)
1	*5670.00	108.7 PK			1.13 V	155	103.80	4.90
2	*5670.00	98.4 AV			1.13 V	155	93.50	4.90
3	#5733.00	68.1 PK	68.3	-0.2	1.00 V	144	63.20	4.90
4	#5834.00	63.4 PK	68.3	-4.9	1.18 V	149	58.30	5.10
5	11340.00	56.1 PK	74.0	-17.9	1.15 V	58	45.30	10.80
6	11340.00	43.2 AV	54.0	-10.8	1.15 V	58	32.40	10.80
7	#17010.00	57.7 PK	68.3	-10.6	1.29 V	108	39.30	18.40

REMARKS:

1. Emission Level(dBuV/m) = Raw Value(dBuV) + Correction Factor(dB/m)
2. Correction Factor(dB/m) = Antenna Factor(dB/m) + Cable Factor(dB) – Pre-Amplifier Factor(dB)
3. The other emission levels were very low against the limit.
4. Margin value = Emission Level – Limit value
5. " * " : Fundamental frequency.
6. " # " : The radiated frequency is out of the restricted band.



A D T

CHANNEL	TX Channel 142	DETECTOR FUNCTION	Peak (PK)
FREQUENCY RANGE	1GHz ~ 40GHz		Average (AV)

ANTENNA POLARITY & TEST DISTANCE: HORIZONTAL AT 3 M

NO.	FREQ. (MHz)	EMISSION LEVEL (dBuV/m)	LIMIT (dBuV/m)	MARGIN (dB)	ANTENNA HEIGHT (m)	TABLE ANGLE (Degree)	RAW VALUE (dBuV)	CORRECTION FACTOR (dB/m)
1	*5710.00	113.2 PK			1.12 H	177	108.30	4.90
2	*5710.00	102.5 AV			1.12 H	177	97.60	4.90
3	#5864.00	67.0 PK	68.3	-1.3	1.15 H	155	61.90	5.10
4	11420.00	56.4 PK	74.0	-17.6	1.10 H	177	45.80	10.60
5	11420.00	42.8 AV	54.0	-11.2	1.10 H	177	32.20	10.60
6	#17130.00	60.5 PK	68.3	-7.8	1.26 H	123	41.60	18.90

ANTENNA POLARITY & TEST DISTANCE: VERTICAL AT 3 M

NO.	FREQ. (MHz)	EMISSION LEVEL (dBuV/m)	LIMIT (dBuV/m)	MARGIN (dB)	ANTENNA HEIGHT (m)	TABLE ANGLE (Degree)	RAW VALUE (dBuV)	CORRECTION FACTOR (dB/m)
1	*5710.00	114.0 PK			1.24 V	168	109.10	4.90
2	*5710.00	105.0 AV			1.24 V	168	100.10	4.90
3	#5864.00	67.9 PK	68.3	-0.4	1.08 V	154	62.80	5.10
4	11420.00	55.6 PK	74.0	-18.4	1.09 V	59	45.00	10.60
5	11420.00	42.8 AV	54.0	-11.2	1.09 V	59	32.20	10.60
6	#17130.00	57.7 PK	68.3	-10.6	1.25 V	110	38.80	18.90

REMARKS:

1. Emission Level(dBuV/m) = Raw Value(dBuV) + Correction Factor(dB/m)
2. Correction Factor(dB/m) = Antenna Factor(dB/m) + Cable Factor(dB) – Pre-Amplifier Factor(dB)
3. The other emission levels were very low against the limit.
4. Margin value = Emission Level – Limit value
5. " * ": Fundamental frequency.
6. " # ": The radiated frequency is out of the restricted band.



A D T

802.11ac (VHT80)

CHANNEL	TX Channel 58	DETECTOR FUNCTION	Peak (PK)
FREQUENCY RANGE	1GHz ~ 40GHz		Average (AV)

ANTENNA POLARITY & TEST DISTANCE: HORIZONTAL AT 3 M

NO.	FREQ. (MHz)	EMISSION LEVEL (dBuV/m)	LIMIT (dBuV/m)	MARGIN (dB)	ANTENNA HEIGHT (m)	TABLE ANGLE (Degree)	RAW VALUE (dBuV)	CORRECTION FACTOR (dB/m)
1	*5290.00	105.7 PK			1.00 H	351	101.40	4.30
2	*5290.00	95.0 AV			1.00 H	351	90.70	4.30
3	5371.00	62.1 PK	74.0	-11.9	1.05 H	340	57.50	4.60
4	5371.00	50.0 AV	54.0	-4.0	1.05 H	340	45.40	4.60
5	#10580.00	56.6 PK	68.3	-11.7	1.05 H	174	46.00	10.60
6	15870.00	60.2 PK	74.0	-13.8	1.32 H	110	45.30	14.90
7	15870.00	47.8 AV	54.0	-6.2	1.32 H	110	32.90	14.90

ANTENNA POLARITY & TEST DISTANCE: VERTICAL AT 3 M

NO.	FREQ. (MHz)	EMISSION LEVEL (dBuV/m)	LIMIT (dBuV/m)	MARGIN (dB)	ANTENNA HEIGHT (m)	TABLE ANGLE (Degree)	RAW VALUE (dBuV)	CORRECTION FACTOR (dB/m)
1	*5290.00	108.1 PK			1.06 V	151	103.80	4.30
2	*5290.00	97.3 AV			1.06 V	151	93.00	4.30
3	5371.00	71.0 PK	74.0	-3.0	1.19 V	159	66.40	4.60
4	5371.00	53.5 AV	54.0	-0.5	1.19 V	159	48.90	4.60
5	#10580.00	55.3 PK	68.3	-13.0	1.08 V	46	44.70	10.60
6	15870.00	57.6 PK	74.0	-16.4	1.19 V	125	42.70	14.90
7	15870.00	46.2 AV	54.0	-7.8	1.19 V	125	31.30	14.90

REMARKS:

1. Emission Level(dBuV/m) = Raw Value(dBuV) + Correction Factor(dB/m)
2. Correction Factor(dB/m) = Antenna Factor(dB/m) + Cable Factor(dB) – Pre-Amplifier Factor(dB)
3. The other emission levels were very low against the limit.
4. Margin value = Emission Level – Limit value
5. " * ": Fundamental frequency.
6. " # ": The radiated frequency is out of the restricted band.



A D T

CHANNEL	TX Channel 106	DETECTOR FUNCTION	Peak (PK)
FREQUENCY RANGE	1GHz ~ 40GHz		Average (AV)

ANTENNA POLARITY & TEST DISTANCE: HORIZONTAL AT 3 M

NO.	FREQ. (MHz)	EMISSION LEVEL (dBuV/m)	LIMIT (dBuV/m)	MARGIN (dB)	ANTENNA HEIGHT (m)	TABLE ANGLE (Degree)	RAW VALUE (dBuV)	CORRECTION FACTOR (dB/m)
1	5460.00	60.1 PK	74.0	-13.9	1.08 H	340	55.50	4.60
2	5460.00	48.2 AV	54.0	-5.8	1.08 H	340	43.60	4.60
3	#5470.00	61.6 PK	68.3	-6.7	1.16 H	338	57.00	4.60
4	*5530.00	101.3 PK			1.05 H	360	96.70	4.60
5	*5530.00	89.9 AV			1.05 H	360	85.30	4.60
6	11060.00	57.0 PK	74.0	-17.0	1.09 H	168	46.30	10.70
7	11060.00	43.7 AV	54.0	-10.3	1.09 H	168	33.00	10.70
8	#16590.00	60.8 PK	68.3	-7.5	1.33 H	109	43.70	17.10

ANTENNA POLARITY & TEST DISTANCE: VERTICAL AT 3 M

NO.	FREQ. (MHz)	EMISSION LEVEL (dBuV/m)	LIMIT (dBuV/m)	MARGIN (dB)	ANTENNA HEIGHT (m)	TABLE ANGLE (Degree)	RAW VALUE (dBuV)	CORRECTION FACTOR (dB/m)
1	5460.00	65.1 PK	74.0	-8.9	1.04 V	146	60.50	4.60
2	5460.00	47.6 AV	54.0	-6.4	1.04 V	146	43.00	4.60
3	#5470.00	68.1 PK	68.3	-0.2	1.04 V	146	63.50	4.60
4	*5530.00	102.7 PK			1.03 V	146	98.10	4.60
5	*5530.00	92.4 AV			1.03 V	146	87.80	4.60
6	11060.00	55.0 PK	74.0	-19.0	1.03 V	57	44.30	10.70
7	11060.00	42.3 AV	54.0	-11.7	1.03 V	57	31.60	10.70
8	#16590.00	57.7 PK	68.3	-10.6	1.13 V	125	40.60	17.10

REMARKS:

1. Emission Level(dBuV/m) = Raw Value(dBuV) + Correction Factor(dB/m)
2. Correction Factor(dB/m) = Antenna Factor(dB/m) + Cable Factor(dB) – Pre-Amplifier Factor(dB)
3. The other emission levels were very low against the limit.
4. Margin value = Emission Level – Limit value
5. " * ": Fundamental frequency.
6. " # ": The radiated frequency is out of the restricted band.



A D T

CHANNEL	TX Channel 138	DETECTOR FUNCTION	Peak (PK)
FREQUENCY RANGE	1GHz ~ 40GHz		Average (AV)

ANTENNA POLARITY & TEST DISTANCE: HORIZONTAL AT 3 M

NO.	FREQ. (MHz)	EMISSION LEVEL (dBuV/m)	LIMIT (dBuV/m)	MARGIN (dB)	ANTENNA HEIGHT (m)	TABLE ANGLE (Degree)	RAW VALUE (dBuV)	CORRECTION FACTOR (dB/m)
1	*5690.00	107.5 PK			1.19 H	360	102.50	5.00
2	*5690.00	96.6 AV			1.19 H	360	91.60	5.00
3	#5833.00	60.9 PK	68.3	-7.4	1.23 H	359	55.80	5.10
4	11380.00	57.3 PK	74.0	-16.7	1.07 H	159	46.60	10.70
5	11380.00	43.9 AV	54.0	-10.1	1.07 H	159	33.20	10.70
6	#17070.00	61.2 PK	68.3	-7.1	1.29 H	104	42.70	18.50

ANTENNA POLARITY & TEST DISTANCE: VERTICAL AT 3 M

NO.	FREQ. (MHz)	EMISSION LEVEL (dBuV/m)	LIMIT (dBuV/m)	MARGIN (dB)	ANTENNA HEIGHT (m)	TABLE ANGLE (Degree)	RAW VALUE (dBuV)	CORRECTION FACTOR (dB/m)
1	#5470.00	63.5 PK	68.3	-4.8	1.05 V	147	58.90	4.60
2	*5690.00	109.4 PK			1.08 V	158	104.40	5.00
3	*5690.00	98.4 AV			1.08 V	158	93.40	5.00
4	#5833.00	68.1 PK	68.3	-0.2	1.17 V	147	63.00	5.10
5	11380.00	55.2 PK	74.0	-18.8	1.00 V	43	44.50	10.70
6	11380.00	42.4 AV	54.0	-11.6	1.00 V	43	31.70	10.70
7	#17070.00	57.3 PK	68.3	-11.0	1.08 V	130	38.80	18.50

REMARKS:

1. Emission Level(dBuV/m) = Raw Value(dBuV) + Correction Factor(dB/m)
2. Correction Factor(dB/m) = Antenna Factor(dB/m) + Cable Factor(dB) – Pre-Amplifier Factor(dB)
3. The other emission levels were very low against the limit.
4. Margin value = Emission Level – Limit value
5. " * ": Fundamental frequency.
6. " # ": The radiated frequency is out of the restricted band.



A D T

4.2.10 TEST RESULTS (MODE 3)

ABOVE 1GHZ DATA

802.11a

CHANNEL	TX Channel 52	DETECTOR FUNCTION	Peak (PK)
FREQUENCY RANGE	1GHz ~ 40GHz		Average (AV)

ANTENNA POLARITY & TEST DISTANCE: HORIZONTAL AT 3 M

NO.	FREQ. (MHz)	EMISSION LEVEL (dBuV/m)	LIMIT (dBuV/m)	MARGIN (dB)	ANTENNA HEIGHT (m)	TABLE ANGLE (Degree)	RAW VALUE (dBuV)	CORRECTION FACTOR (dB/m)
1	5100.00	50.6 PK	74.0	-23.4	1.00 H	75	46.50	4.10
2	5100.00	39.0 AV	54.0	-15.0	1.00 H	75	34.90	4.10
3	*5260.00	96.3 PK			1.00 H	75	91.90	4.40
4	*5260.00	84.7 AV			1.00 H	75	80.30	4.40
5	5380.00	48.5 PK	74.0	-25.5	1.02 H	78	43.80	4.70
6	5380.00	39.3 AV	54.0	-14.7	1.02 H	78	34.60	4.70
7	5420.00	52.9 PK	74.0	-21.1	1.01 H	83	48.30	4.60
8	5420.00	42.8 AV	54.0	-11.2	1.01 H	83	38.20	4.60
9	#10520.00	55.6 PK	68.3	-12.7	1.02 H	243	45.20	10.40
10	15780.00	60.2 PK	74.0	-13.8	1.00 H	105	45.50	14.70
11	15780.00	48.8 AV	54.0	-5.2	1.00 H	105	34.10	14.70

ANTENNA POLARITY & TEST DISTANCE: VERTICAL AT 3 M

NO.	FREQ. (MHz)	EMISSION LEVEL (dBuV/m)	LIMIT (dBuV/m)	MARGIN (dB)	ANTENNA HEIGHT (m)	TABLE ANGLE (Degree)	RAW VALUE (dBuV)	CORRECTION FACTOR (dB/m)
1	5100.00	62.8 PK	74.0	-11.2	1.04 V	135	58.70	4.10
2	5100.00	51.4 AV	54.0	-2.6	1.04 V	135	47.30	4.10
3	*5260.00	108.4 PK			1.00 V	205	104.00	4.40
4	*5260.00	98.3 AV			1.00 V	205	93.90	4.40
5	5380.00	62.0 PK	74.0	-12.0	1.08 V	145	57.30	4.70
6	5380.00	50.4 AV	54.0	-3.6	1.08 V	145	45.70	4.70
7	5420.00	69.8 PK	74.0	-4.2	1.19 V	145	65.20	4.60
8	5420.00	53.8 AV	54.0	-0.2	1.19 V	145	49.20	4.60
9	#10520.00	57.2 PK	68.3	-11.1	1.00 V	301	46.80	10.40
10	15780.00	57.2 PK	74.0	-16.8	1.00 V	214	42.50	14.70
11	15780.00	42.1 AV	54.0	-11.9	1.00 V	214	27.40	14.70

REMARKS:

1. Emission Level(dBuV/m) = Raw Value(dBuV) + Correction Factor(dB/m)
2. Correction Factor(dB/m) = Antenna Factor(dB/m) + Cable Factor(dB) – Pre-Amplifier Factor(dB)
3. The other emission levels were very low against the limit.
4. Margin value = Emission Level – Limit value
5. " * ": Fundamental frequency.
6. " # ": The radiated frequency is out of the restricted band.



A D T

CHANNEL	TX Channel 60	DETECTOR FUNCTION	Peak (PK)
FREQUENCY RANGE	1GHz ~ 40GHz		Average (AV)

ANTENNA POLARITY & TEST DISTANCE: HORIZONTAL AT 3 M

NO.	FREQ. (MHz)	EMISSION LEVEL (dBuV/m)	LIMIT (dBuV/m)	MARGIN (dB)	ANTENNA HEIGHT (m)	TABLE ANGLE (Degree)	RAW VALUE (dBuV)	CORRECTION FACTOR (dB/m)
1	*5300.00	93.3 PK			1.09 H	74	88.90	4.40
2	*5300.00	83.3 AV			1.09 H	74	78.90	4.40
3	5381.00	53.0 PK	74.0	-21.0	1.00 H	76	48.30	4.70
4	5381.00	42.3 AV	54.0	-11.7	1.00 H	76	37.60	4.70
5	5458.00	53.1 PK	74.0	-20.9	1.17 H	81	48.50	4.60
6	5458.00	41.6 AV	54.0	-12.4	1.17 H	81	37.00	4.60
7	10600.00	54.9 PK	74.0	-19.1	1.04 H	258	44.30	10.60
8	10600.00	42.1 AV	54.0	-11.9	1.04 H	258	31.50	10.60
9	15900.00	60.3 PK	74.0	-13.7	1.05 H	116	45.20	15.10
10	15900.00	48.6 AV	54.0	-5.4	1.05 H	116	33.50	15.10

ANTENNA POLARITY & TEST DISTANCE: VERTICAL AT 3 M

NO.	FREQ. (MHz)	EMISSION LEVEL (dBuV/m)	LIMIT (dBuV/m)	MARGIN (dB)	ANTENNA HEIGHT (m)	TABLE ANGLE (Degree)	RAW VALUE (dBuV)	CORRECTION FACTOR (dB/m)
1	*5300.00	107.1 PK			1.20 V	199	102.70	4.40
2	*5300.00	96.6 AV			1.20 V	199	92.20	4.40
3	5381.00	65.0 PK	74.0	-9.0	1.08 V	212	60.30	4.70
4	5381.00	53.4 AV	54.0	-0.6	1.08 V	212	48.70	4.70
5	5458.00	64.9 PK	74.0	-9.1	1.06 V	209	60.30	4.60
6	5458.00	53.3 AV	54.0	-0.7	1.06 V	209	48.70	4.60
7	10600.00	57.3 PK	74.0	-16.7	1.02 V	291	46.70	10.60
8	10600.00	42.5 AV	54.0	-11.5	1.02 V	291	31.90	10.60
9	15900.00	57.8 PK	74.0	-16.2	1.03 V	204	42.70	15.10
10	15900.00	42.4 AV	54.0	-11.6	1.03 V	204	27.30	15.10

REMARKS:

1. Emission Level(dBuV/m) = Raw Value(dBuV) + Correction Factor(dB/m)
2. Correction Factor(dB/m) = Antenna Factor(dB/m) + Cable Factor(dB) – Pre-Amplifier Factor(dB)
3. The other emission levels were very low against the limit.
4. Margin value = Emission Level – Limit value
5. " * ": Fundamental frequency.



A D T

CHANNEL	TX Channel 64	DETECTOR FUNCTION	Peak (PK)
FREQUENCY RANGE	1GHz ~ 40GHz		Average (AV)

ANTENNA POLARITY & TEST DISTANCE: HORIZONTAL AT 3 M

NO.	FREQ. (MHz)	EMISSION LEVEL (dBuV/m)	LIMIT (dBuV/m)	MARGIN (dB)	ANTENNA HEIGHT (m)	TABLE ANGLE (Degree)	RAW VALUE (dBuV)	CORRECTION FACTOR (dB/m)
1	*5320.00	92.6 PK			1.00 H	77	88.20	4.40
2	*5320.00	83.3 AV			1.00 H	77	78.90	4.40
3	5400.00	52.7 PK	74.0	-21.3	1.10 H	78	48.00	4.70
4	5400.00	41.1 AV	54.0	-12.9	1.10 H	78	36.40	4.70
5	#5480.00	52.9 PK	68.3	-15.4	1.10 H	78	48.30	4.60
6	10640.00	55.3 PK	74.0	-18.7	1.01 H	258	44.70	10.60
7	10640.00	42.3 AV	54.0	-11.7	1.01 H	258	31.70	10.60
8	15960.00	60.4 PK	74.0	-13.6	1.07 H	108	45.50	14.90
9	15960.00	48.5 AV	54.0	-5.5	1.07 H	108	33.60	14.90

ANTENNA POLARITY & TEST DISTANCE: VERTICAL AT 3 M

NO.	FREQ. (MHz)	EMISSION LEVEL (dBuV/m)	LIMIT (dBuV/m)	MARGIN (dB)	ANTENNA HEIGHT (m)	TABLE ANGLE (Degree)	RAW VALUE (dBuV)	CORRECTION FACTOR (dB/m)
1	*5320.00	107.4 PK			1.10 V	210	103.00	4.40
2	*5320.00	96.4 AV			1.10 V	210	92.00	4.40
3	5400.00	64.2 PK	74.0	-9.8	1.07 V	205	59.50	4.70
4	5400.00	53.3 AV	54.0	-0.7	1.07 V	205	48.60	4.70
5	#5480.00	64.5 PK	68.3	-3.8	1.05 V	210	59.90	4.60
6	10640.00	57.4 PK	74.0	-16.6	1.03 V	291	46.80	10.60
7	10640.00	42.4 AV	54.0	-11.6	1.03 V	291	31.80	10.60
8	15960.00	57.7 PK	74.0	-16.3	1.02 V	199	42.80	14.90
9	15960.00	42.5 AV	54.0	-11.5	1.02 V	199	27.60	14.90

REMARKS:

1. Emission Level(dBuV/m) = Raw Value(dBuV) + Correction Factor(dB/m)
2. Correction Factor(dB/m) = Antenna Factor(dB/m) + Cable Factor(dB) – Pre-Amplifier Factor(dB)
3. The other emission levels were very low against the limit.
4. Margin value = Emission Level – Limit value
5. " * ": Fundamental frequency.
6. " # ": The radiated frequency is out of the restricted band.



A D T

CHANNEL	TX Channel 100	DETECTOR FUNCTION	Peak (PK)
FREQUENCY RANGE	1GHz ~ 40GHz		Average (AV)

ANTENNA POLARITY & TEST DISTANCE: HORIZONTAL AT 3 M

NO.	FREQ. (MHz)	EMISSION LEVEL (dBuV/m)	LIMIT (dBuV/m)	MARGIN (dB)	ANTENNA HEIGHT (m)	TABLE ANGLE (Degree)	RAW VALUE (dBuV)	CORRECTION FACTOR (dB/m)
1	5417.00	53.6 PK	74.0	-20.4	1.23 H	78	49.00	4.60
2	5417.00	41.9 AV	54.0	-12.1	1.23 H	78	37.30	4.60
3	*5500.00	95.6 PK			1.00 H	84	91.00	4.60
4	*5500.00	86.3 AV			1.00 H	84	81.70	4.60
5	11000.00	55.7 PK	74.0	-18.3	1.04 H	260	44.90	10.80
6	11000.00	42.7 AV	54.0	-11.3	1.04 H	260	31.90	10.80
7	#16500.00	59.7 PK	68.3	-8.6	1.05 H	94	42.70	17.00

ANTENNA POLARITY & TEST DISTANCE: VERTICAL AT 3 M

NO.	FREQ. (MHz)	EMISSION LEVEL (dBuV/m)	LIMIT (dBuV/m)	MARGIN (dB)	ANTENNA HEIGHT (m)	TABLE ANGLE (Degree)	RAW VALUE (dBuV)	CORRECTION FACTOR (dB/m)
1	5417.00	65.2 PK	74.0	-8.8	1.07 V	211	60.60	4.60
2	5417.00	53.7 AV	54.0	-0.3	1.07 V	211	49.10	4.60
3	*5500.00	109.7 PK			1.05 V	149	105.10	4.60
4	*5500.00	99.6 AV			1.05 V	149	95.00	4.60
5	11000.00	57.7 PK	74.0	-16.3	1.03 V	289	46.90	10.80
6	11000.00	42.6 AV	54.0	-11.4	1.03 V	289	31.80	10.80
7	#16500.00	58.3 PK	68.3	-10.0	1.00 V	210	41.30	17.00

REMARKS:

1. Emission Level(dBuV/m) = Raw Value(dBuV) + Correction Factor(dB/m)
2. Correction Factor(dB/m) = Antenna Factor(dB/m) + Cable Factor(dB) – Pre-Amplifier Factor(dB)
3. The other emission levels were very low against the limit.
4. Margin value = Emission Level – Limit value
5. " * " : Fundamental frequency.
6. " # " : The radiated frequency is out of the restricted band.



A D T

CHANNEL	TX Channel 116	DETECTOR FUNCTION	Peak (PK)
FREQUENCY RANGE	1GHz ~ 40GHz		Average (AV)

ANTENNA POLARITY & TEST DISTANCE: HORIZONTAL AT 3 M

NO.	FREQ. (MHz)	EMISSION LEVEL (dBuV/m)	LIMIT (dBuV/m)	MARGIN (dB)	ANTENNA HEIGHT (m)	TABLE ANGLE (Degree)	RAW VALUE (dBuV)	CORRECTION FACTOR (dB/m)
1	5420.00	52.8 PK	74.0	-21.2	1.06 H	76	48.20	4.60
2	5420.00	41.4 AV	54.0	-12.6	1.06 H	76	36.80	4.60
3	*5580.00	95.8 PK			1.10 H	80	90.90	4.90
4	*5580.00	86.3 AV			1.10 H	80	81.40	4.90
5	#5740.00	54.8 PK	68.3	-13.5	1.28 H	264	49.90	4.90
6	11160.00	56.1 PK	74.0	-17.9	1.00 H	266	45.40	10.70
7	11160.00	43.1 AV	54.0	-10.9	1.00 H	266	32.40	10.70
8	#16740.00	59.5 PK	68.3	-8.8	1.08 H	87	41.60	17.90

ANTENNA POLARITY & TEST DISTANCE: VERTICAL AT 3 M

NO.	FREQ. (MHz)	EMISSION LEVEL (dBuV/m)	LIMIT (dBuV/m)	MARGIN (dB)	ANTENNA HEIGHT (m)	TABLE ANGLE (Degree)	RAW VALUE (dBuV)	CORRECTION FACTOR (dB/m)
1	5420.00	63.2 PK	74.0	-10.8	1.28 V	201	58.60	4.60
2	5420.00	52.1 AV	54.0	-1.9	1.28 V	201	47.50	4.60
3	*5580.00	110.5 PK			1.14 V	167	105.60	4.90
4	*5580.00	100.5 AV			1.14 V	167	95.60	4.90
5	#5740.00	68.0 PK	68.3	-0.3	1.00 V	211	63.10	4.90
6	11160.00	57.9 PK	74.0	-16.1	1.06 V	288	47.20	10.70
7	11160.00	42.9 AV	54.0	-11.1	1.06 V	288	32.20	10.70
8	#16740.00	57.9 PK	68.3	-10.4	1.06 V	203	40.00	17.90

REMARKS:

1. Emission Level(dBuV/m) = Raw Value(dBuV) + Correction Factor(dB/m)
2. Correction Factor(dB/m) = Antenna Factor(dB/m) + Cable Factor(dB) – Pre-Amplifier Factor(dB)
3. The other emission levels were very low against the limit.
4. Margin value = Emission Level – Limit value
5. " * ": Fundamental frequency.
6. " # ": The radiated frequency is out of the restricted band.



A D T

CHANNEL	TX Channel 132	DETECTOR FUNCTION	Peak (PK)
FREQUENCY RANGE	1GHz ~ 40GHz		Average (AV)

ANTENNA POLARITY & TEST DISTANCE: HORIZONTAL AT 3 M

NO.	FREQ. (MHz)	EMISSION LEVEL (dBuV/m)	LIMIT (dBuV/m)	MARGIN (dB)	ANTENNA HEIGHT (m)	TABLE ANGLE (Degree)	RAW VALUE (dBuV)	CORRECTION FACTOR (dB/m)
1	*5660.00	95.8 PK			1.10 H	74	90.90	4.90
2	*5660.00	85.8 AV			1.10 H	74	80.90	4.90
3	#5740.00	56.3 PK	68.3	-12.0	1.00 H	78	51.40	4.90
4	#5820.00	55.5 PK	68.3	-12.8	1.00 H	77	50.40	5.10
5	11320.00	56.4 PK	74.0	-17.6	1.00 H	280	45.60	10.80
6	11320.00	43.3 AV	54.0	-10.7	1.00 H	280	32.50	10.80
7	#16980.00	59.7 PK	68.3	-8.6	1.13 H	92	41.30	18.40

ANTENNA POLARITY & TEST DISTANCE: VERTICAL AT 3 M

NO.	FREQ. (MHz)	EMISSION LEVEL (dBuV/m)	LIMIT (dBuV/m)	MARGIN (dB)	ANTENNA HEIGHT (m)	TABLE ANGLE (Degree)	RAW VALUE (dBuV)	CORRECTION FACTOR (dB/m)
1	*5660.00	109.3 PK			1.13 V	161	104.40	4.90
2	*5660.00	98.8 AV			1.13 V	161	93.90	4.90
3	#5740.00	68.1 PK	68.3	-0.2	1.11 V	205	63.20	4.90
4	#5820.00	65.8 PK	68.3	-2.5	1.08 V	205	60.70	5.10
5	11320.00	57.9 PK	74.0	-16.1	1.05 V	287	47.10	10.80
6	11320.00	43.1 AV	54.0	-10.9	1.05 V	287	32.30	10.80
7	#16980.00	57.9 PK	68.3	-10.4	1.07 V	216	39.50	18.40

REMARKS:

1. Emission Level(dBuV/m) = Raw Value(dBuV) + Correction Factor(dB/m)
2. Correction Factor(dB/m) = Antenna Factor(dB/m) + Cable Factor(dB) – Pre-Amplifier Factor(dB)
3. The other emission levels were very low against the limit.
4. Margin value = Emission Level – Limit value
5. " * " : Fundamental frequency.
6. " # " : The radiated frequency is out of the restricted band.



A D T

CHANNEL	TX Channel 140	DETECTOR FUNCTION	Peak (PK)
FREQUENCY RANGE	1GHz ~ 40GHz		Average (AV)

ANTENNA POLARITY & TEST DISTANCE: HORIZONTAL AT 3 M

NO.	FREQ. (MHz)	EMISSION LEVEL (dBuV/m)	LIMIT (dBuV/m)	MARGIN (dB)	ANTENNA HEIGHT (m)	TABLE ANGLE (Degree)	RAW VALUE (dBuV)	CORRECTION FACTOR (dB/m)
1	*5700.00	97.9 PK			1.09 H	272	93.00	4.90
2	*5700.00	86.2 AV			1.09 H	272	81.30	4.90
3	#5780.00	59.4 PK	68.3	-8.9	1.07 H	272	54.50	4.90
4	#5860.00	59.9 PK	68.3	-8.4	1.05 H	272	54.80	5.10
5	11400.00	56.8 PK	74.0	-17.2	1.06 H	267	46.10	10.70
6	11400.00	43.6 AV	54.0	-10.4	1.06 H	267	32.90	10.70
7	#17100.00	60.0 PK	68.3	-8.3	1.12 H	90	41.40	18.60

ANTENNA POLARITY & TEST DISTANCE: VERTICAL AT 3 M

NO.	FREQ. (MHz)	EMISSION LEVEL (dBuV/m)	LIMIT (dBuV/m)	MARGIN (dB)	ANTENNA HEIGHT (m)	TABLE ANGLE (Degree)	RAW VALUE (dBuV)	CORRECTION FACTOR (dB/m)
1	*5700.00	109.5 PK			1.02 V	212	104.60	4.90
2	*5700.00	98.9 AV			1.02 V	212	94.00	4.90
3	#5780.00	68.0 PK	68.3	-0.3	1.10 V	199	63.10	4.90
4	#5860.00	65.4 PK	68.3	-2.9	1.08 V	204	60.30	5.10
5	11400.00	58.4 PK	74.0	-15.6	1.03 V	279	47.70	10.70
6	11400.00	43.3 AV	54.0	-10.7	1.03 V	279	32.60	10.70
7	#17100.00	58.2 PK	68.3	-10.1	1.11 V	221	39.60	18.60

REMARKS:

1. Emission Level(dBuV/m) = Raw Value(dBuV) + Correction Factor(dB/m)
2. Correction Factor(dB/m) = Antenna Factor(dB/m) + Cable Factor(dB) – Pre-Amplifier Factor(dB)
3. The other emission levels were very low against the limit.
4. Margin value = Emission Level – Limit value
5. " * ": Fundamental frequency.
6. " # ": The radiated frequency is out of the restricted band.



A D T

CHANNEL	TX Channel 144	DETECTOR FUNCTION	Peak (PK)
FREQUENCY RANGE	1GHz ~ 40GHz		Average (AV)

ANTENNA POLARITY & TEST DISTANCE: HORIZONTAL AT 3 M

NO.	FREQ. (MHz)	EMISSION LEVEL (dBuV/m)	LIMIT (dBuV/m)	MARGIN (dB)	ANTENNA HEIGHT (m)	TABLE ANGLE (Degree)	RAW VALUE (dBuV)	CORRECTION FACTOR (dB/m)
1	*5720.00	99.7 PK			1.09 H	272	94.80	4.90
2	*5720.00	90.3 AV			1.09 H	272	85.40	4.90
3	#5881.00	58.2 PK	68.3	-10.1	1.07 H	76	53.10	5.10
4	11440.00	56.3 PK	74.0	-17.7	1.08 H	256	45.70	10.60
5	11440.00	43.1 AV	54.0	-10.9	1.08 H	256	32.50	10.60
6	#17160.00	59.9 PK	68.3	-8.4	1.06 H	102	40.80	19.10

ANTENNA POLARITY & TEST DISTANCE: VERTICAL AT 3 M

NO.	FREQ. (MHz)	EMISSION LEVEL (dBuV/m)	LIMIT (dBuV/m)	MARGIN (dB)	ANTENNA HEIGHT (m)	TABLE ANGLE (Degree)	RAW VALUE (dBuV)	CORRECTION FACTOR (dB/m)
1	*5720.00	111.1 PK			1.09 V	175	106.20	4.90
2	*5720.00	101.1 AV			1.09 V	175	96.20	4.90
3	#5881.00	68.0 PK	68.3	-0.3	1.05 V	160	62.90	5.10
4	11440.00	58.5 PK	74.0	-15.5	1.09 V	283	47.90	10.60
5	11440.00	43.1 AV	54.0	-10.9	1.09 V	283	32.50	10.60
6	#17160.00	58.6 PK	68.3	-9.7	1.05 V	211	39.50	19.10

REMARKS:

1. Emission Level(dBuV/m) = Raw Value(dBuV) + Correction Factor(dB/m)
2. Correction Factor(dB/m) = Antenna Factor(dB/m) + Cable Factor(dB) – Pre-Amplifier Factor(dB)
3. The other emission levels were very low against the limit.
4. Margin value = Emission Level – Limit value
5. " * ": Fundamental frequency.
6. " # ": The radiated frequency is out of the restricted band.



4.3 TRANSMIT POWER MEASUREMENT

4.3.1 LIMITS OF TRANSMIT POWER MEASUREMENT

Frequency Band	Limit
5.15 – 5.25GHz	The lesser of 50mW (17dBm) or 4dBm + 10logB
5.25 – 5.35GHz	The lesser of 250mW (24dBm) or 11dBm + 10logB
5.47 – 5.725GHz	The lesser of 250mW (24dBm) or 11dBm + 10logB
5.725 – 5.825GHz	The lesser of 1W (30dBm) or 17dBm + 10logB

Note: Where B is the 26dB emission bandwidth in MHz.

Per KDB 662911 D01 Multiple Transmitter Output Method of conducted output power measurement on IEEE 802.11 devices,

Array Gain = 0 dB (i.e., no array gain) for NANT ≤ 4;

Array Gain = 0 dB (i.e., no array gain) for channel widths ≥ 40 MHz for any NANT;

Array Gain = 5 log(NANT/NSS) dB or 3 dB, whichever is less for 20-MHz channel widths with NANT ≥ 5.

For power measurements on all other devices: Array Gain = 10 log(NANT/NSS) dB.

4.3.2 TEST INSTRUMENTS

FOR POWER OUTPUT MEASUREMENT

DESCRIPTION & MANUFACTURER	MODEL NO.	SERIAL NO.	CALIBRATED DATE	CALIBRATED UNTIL
Power meter Anritsu	ML2495A	1014008	Apr. 30, 2014	Apr. 29, 2015
Power sensor Anritsu	MA2411B	0917122	Apr. 30, 2014	Apr. 29, 2015
SPECTRUM ANALYZER R&S	FSV 40	100964	July 15, 2013	July 14, 2014

Note:

1. The calibration interval of the above test instruments is 12 months and the calibrations are traceable to NML/ROC and NIST/USA.
2. Tested date : May 05, 2014



A D T

FOR 26dB OCCUPIED BANDWIDTH

DESCRIPTION & MANUFACTURER	MODEL NO.	SERIAL NO.	CALIBRATED DATE	CALIBRATED UNTIL
SPECTRUM ANALYZER R&S	FSV 40	100964	July 15, 2013	July 14, 2014

Note:

1. The calibration interval of the above test instruments is 12 months and the calibrations are traceable to NML/ROC and NIST/USA.
2. Tested date : May 05, 2014

4.3.3 TEST PROCEDURE

FOR POWER OUTPUT MEASUREMENT

For channel straddling 5725MHz:

Follow FCC KDB 789033 UNII test procedure:
Method SA-2

1. Set span to encompass the emission bandwidth (EBW) of the signal.
2. Set RBW = 1MHz.
3. Set the VBW $\geq 3 \times$ RBW.
4. Number of points in sweep ≥ 2 Span / RBW.
5. Sweep time = auto.
6. Detector = RMS.
7. Trace average at least 100 traces in power averaging mode
8. Compute power by integrating the spectrum across the 26 dB EBW of the signal.
9. Duty factor need added to measured value (duty cycle < 98 percent).

For other channels:

Method PM is used to perform output power measurement, trigger and gating function of wide band power meter is enabled to measure max output power of TX on burst. Duty factor is not added to measured value.



A D T

FOR 26dB OCCUPIED BANDWIDTH

1. Set RBW = approximately 1% of the emission bandwidth.
2. Set the VBW > RBW.
3. Detector = Peak.
4. Trace mode = max hold.
5. Measure the maximum width of the emission that is 26 dB down from the peak of the emission. Compare this with the RBW setting of the analyzer. Readjust RBW and repeat measurement as needed until the RBW/EBW ratio is approximately 1%.

4.3.4 DEVIATION FROM TEST STANDARD

No deviation

4.3.5 TEST SETUP

FOR POWER OUTPUT MEASUREMENT

For channel straddling 5725MHz:



For other channels:

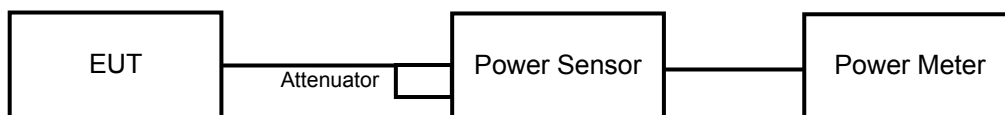

FOR 26dB OCCUPIED BANDWIDTH

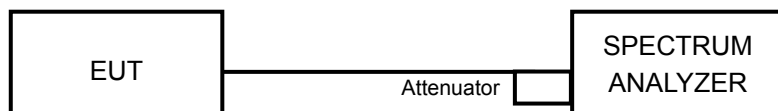

4.3.6 EUT OPERATING CONDITIONS

The software provided by client to enable the EUT under transmission condition continuously at specific channel frequencies individually.



4.3.7 TEST RESULTS (MODE 1)

POWER OUTPUT:

CDD, SDM & Beamforming (MCS0 NSS=3)_MODE								
CHANNEL	FREQUENCY (MHz)	AVERAGE POWER (dBm)			TOTAL POWER (mW)	TOTAL POWER (dBm)	POWER LIMIT (dBm)	PASS / FAIL
		CHAIN 0	CHAIN 1	CHAIN 2				
802.11ac (VHT20)								
52	5260	6.32	8.13	4.41	13.547	11.32	24	PASS
60	5300	5.99	8.17	3.89	12.982	11.13	24	PASS
64	5320	5.98	7.87	3.69	12.426	10.94	24	PASS
100	5500	7.41	7.93	7.33	17.125	12.34	24	PASS
116	5580	11.60	12.10	11.49	44.765	16.51	24	PASS
132	5660	9.96	10.40	9.39	29.563	14.71	24	PASS
140	5700	9.56	10.02	9.03	27.080	14.33	24	PASS
144 (UNII-2c Band)	5720	13.03	14.07	13.31	67.047	18.26	22.84	PASS
144 (UNII-3 Band)	5720	7.12	7.97	7.86	17.527	12.44	24.20	PASS
802.11ac (VHT40)								
54	5270	10.26	11.39	9.14	32.593	15.13	24	PASS
62	5310	9.01	10.12	8.79	25.810	14.12	24	PASS
102	5510	10.15	10.63	7.62	27.693	14.42	24	PASS
110	5550	11.71	12.42	11.60	46.737	16.70	24	PASS
134	5670	10.62	11.06	10.15	34.650	15.40	24	PASS
142 (UNII-2c Band)	5710	11.48	12.97	12.80	52.930	17.24	24	PASS
142 (UNII-3 Band)	5710	1.10	2.56	2.65	4.932	6.93	24.36	PASS
802.11ac (VHT80)								
58	5290	11.01	12.17	10.12	39.38	15.95	24	PASS
106	5530	8.89	10.39	9.25	27.099	14.33	24	PASS
138 (UNII-2c Band)	5690	11.36	12.55	12.77	52.37	17.19	24	PASS
138 (UNII-3 Band)	5690	-2.93	-1.42	-1.05	2.0859	3.19	25.15	PASS
For CH138: Average Power (dBm)= measured value(dBm) + Duty Factor (0.15dB)								



26dB OCCUPIED BANDWIDTH:

CHANNEL	CHANNEL FREQUENCY (MHz)	26dBc BANDWIDTH (MHz)		
		CHAIN 0	CHAIN 1	CHAIN 2
802.11ac (VHT20)				
52	5260	20.65	20.52	20.52
60	5300	20.66	20.38	20.55
64	5320	20.74	20.48	20.59
100	5500	20.85	20.56	20.58
116	5580	20.79	20.54	20.52
132	5660	20.94	20.45	20.68
140	5700	20.79	20.56	20.72
144 (UNII-2c Band)	5720	15.36	15.28	15.28
144 (UNII-3 Band)	5720	5.35	5.25	5.33
802.11ac (VHT40)				
54	5270	41.60	40.91	41.09
62	5310	41.63	41.26	40.84
102	5510	41.56	41.55	40.67
110	5550	41.57	41.26	40.95
134	5670	41.61	41.42	41.77
142 (UNII-2c Band)	5710	35.74	35.62	35.57
142 (UNII-3 Band)	5710	5.66	6.03	5.45
802.11ac (VHT80)				
58	5290	82.93	82.76	82.28
106	5530	82.87	83.75	82.34
138 (UNII-2c Band)	5690	76.68	78.20	76.24
138 (UNII-3 Band)	5690	6.54	6.71	6.61

Note: For output power limitation is determined based on 26dBc bandwidth.



A D T

Power Limit = 11dBm + 10logB < UNII Band 2~3>			
Channel Number	Freq.(MHz)	Min. B(MHz)	Determined Conducted Limit (dBm)
802.11ac (VHT20)			
52	5260	20.52	24.12 > 24
60	5300	20.38	24.09 > 24
64	5320	20.48	24.11 > 24
100	5500	20.56	24.13 > 24
116	5580	20.52	24.12 > 24
132	5660	20.45	24.1 > 24
140	5700	20.56	24.13 > 24
144 (UNII-2c Band)	5720	15.28	22.84 < 24
144 (UNII-3 Band)	5720	5.25	24.2 < 30
802.11ac (VHT40)			
54	5270	40.91	27.11 > 24
62	5310	40.84	27.11 > 24
102	5510	40.67	27.09 > 24
110	5550	40.95	27.12 > 24
134	5670	41.42	27.17 > 24
142 (UNII-2c Band)	5710	35.57	26.5 > 24
142 (UNII-3 Band)	5710	5.45	24.36 < 30
802.11ac (VHT80)			
58	5290	82.28	30.15 > 24
106	5530	82.34	30.15 > 24
138 (UNII-2c Band)	5690	76.24	29.82 > 24
138 (UNII-3 Band)	5690	6.54	25.15 < 30



A D T

802.11ac (VHT20)

For Chain (0)

CH52

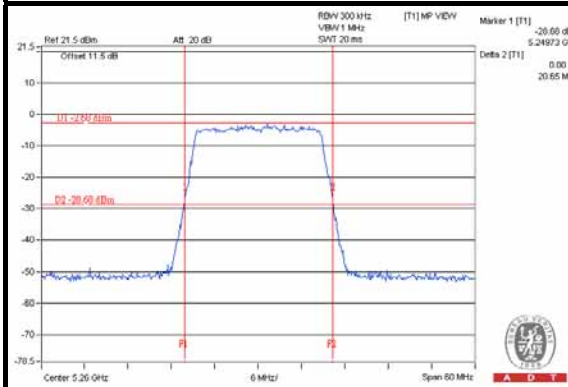

CH60

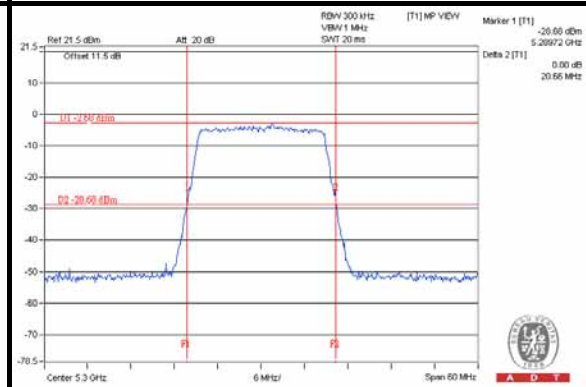

CH64

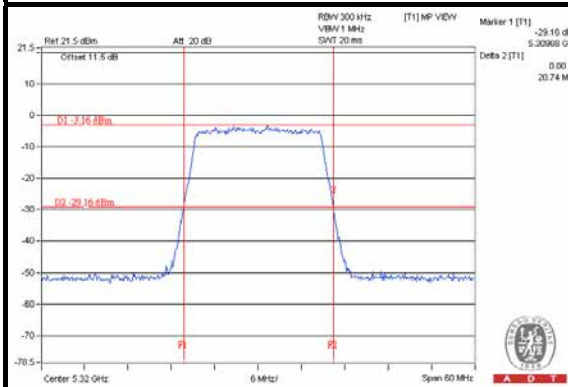

CH100

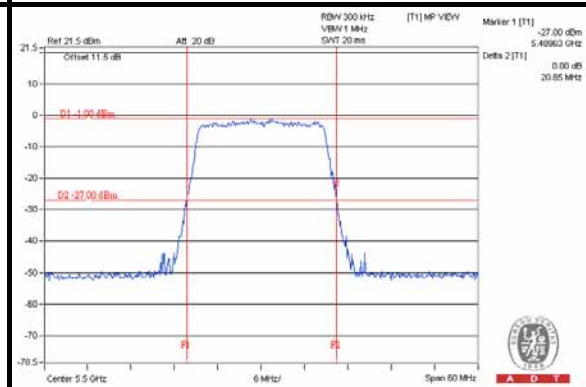

CH116

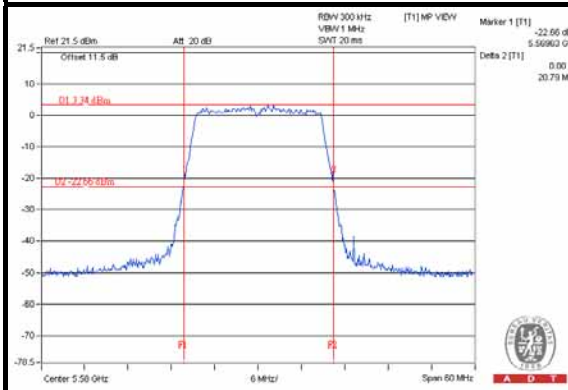

CH132

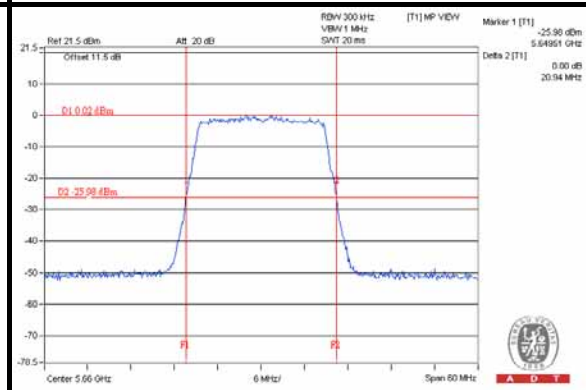



A D T

CH140

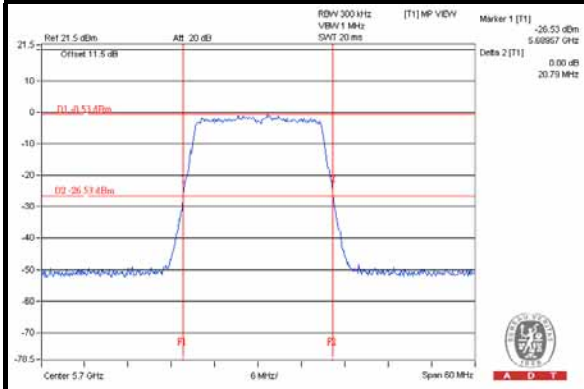

CH144 (UNII-2c Band) / CH144 (UNII-3 Band)

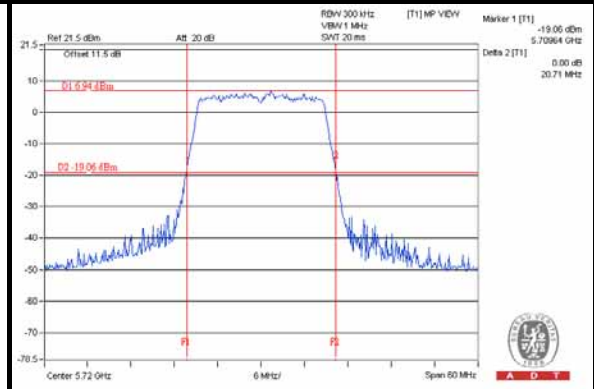

NOTE:

For CH144 (UNII-2c Band) = 5725 - Market 1

For CH144 (UNII-3 Band) = Delta 2 - CH144 (UNII-2c Band) BW

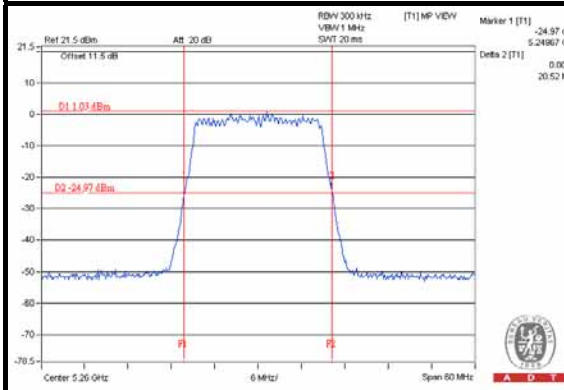
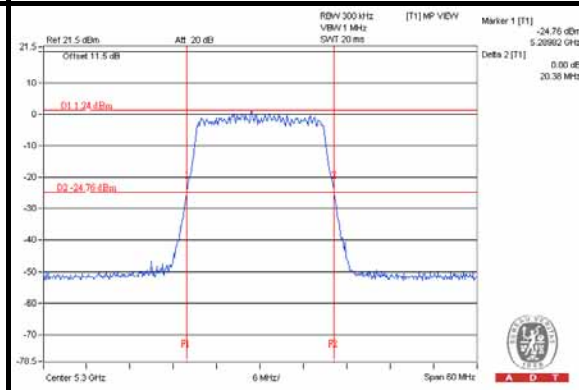
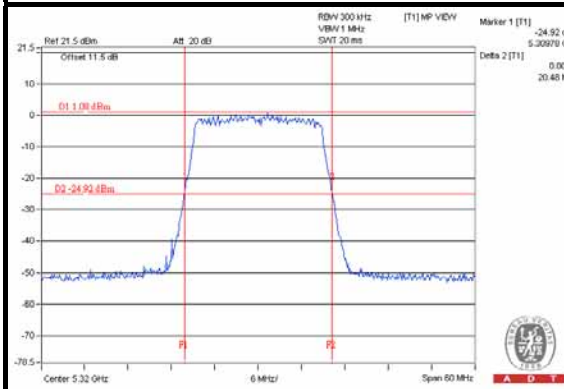
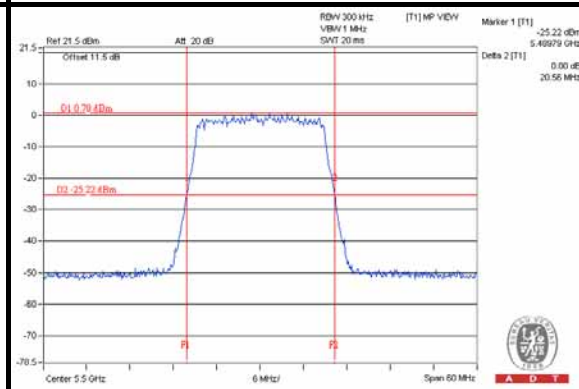
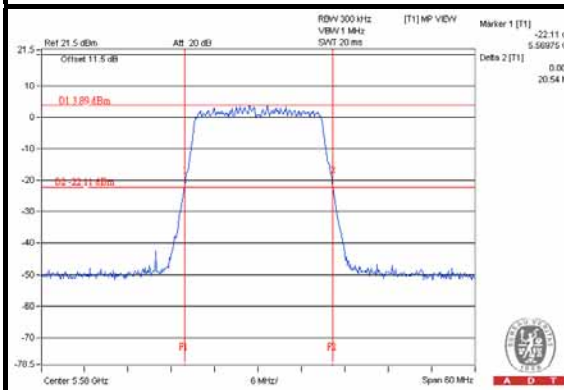
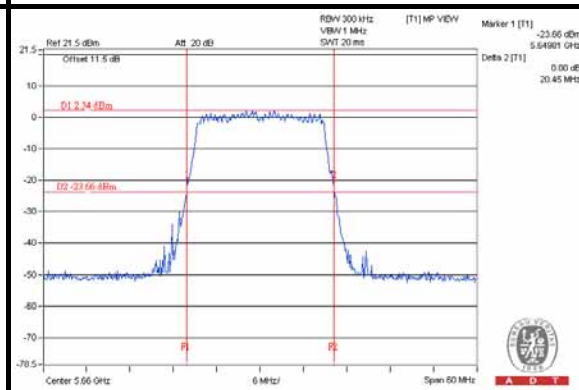
For Chain (1)**CH52****CH60****CH64****CH100****CH116****CH132**



A D T

CH140

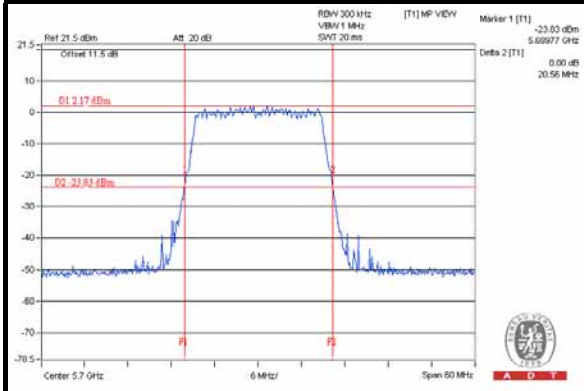

CH144 (UNII-2c Band) / CH144 (UNII-3 Band)

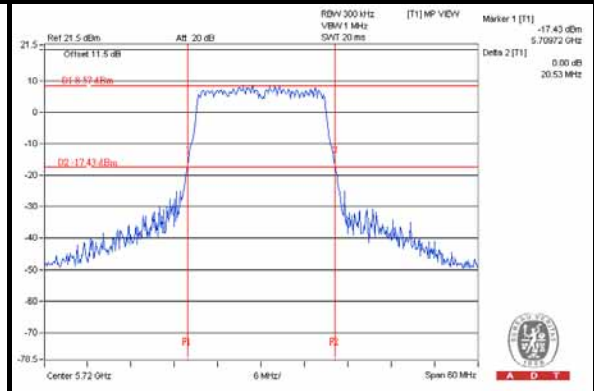

NOTE:

For CH144 (UNII-2c Band) = 5725 - Market 1

For CH144 (UNII-3 Band) = Delta 2 - CH144 (UNII-2c Band) BW



A D T

For Chain (2)

CH52

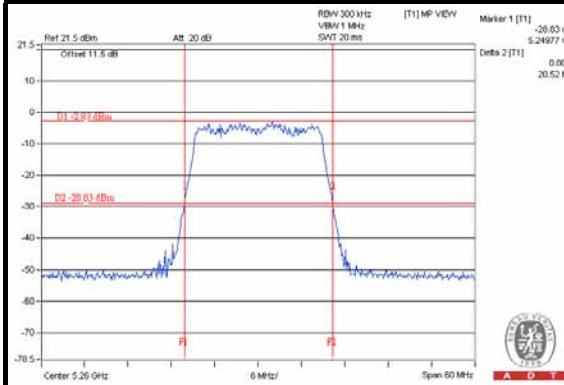

CH60

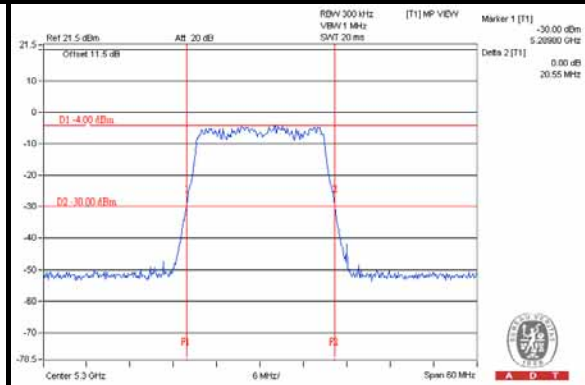

CH64

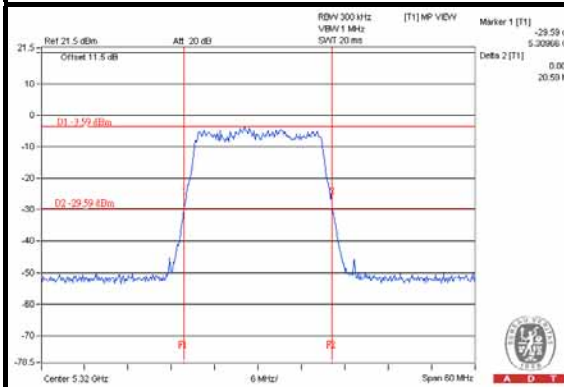

CH100

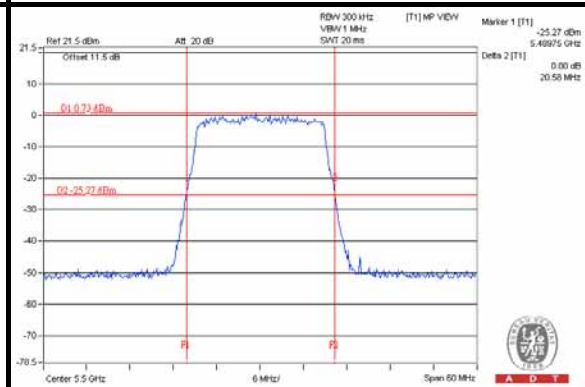

CH116

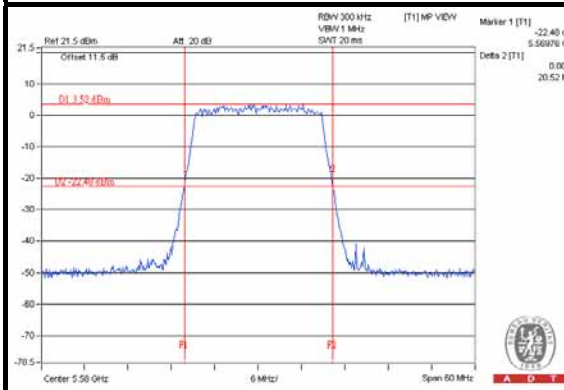

CH132

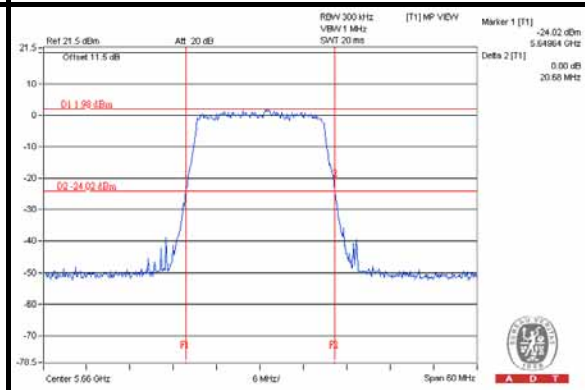



A D T

CH140

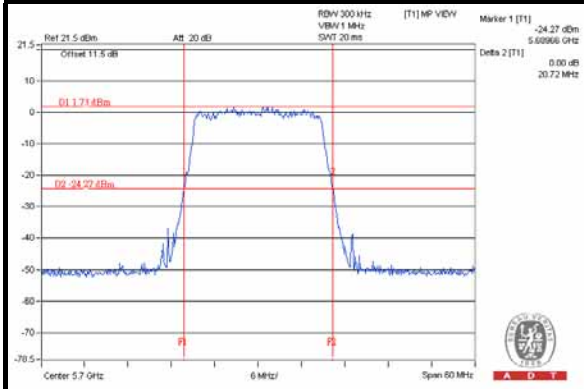

CH144 (UNII-2c Band) / CH144 (UNII-3 Band)

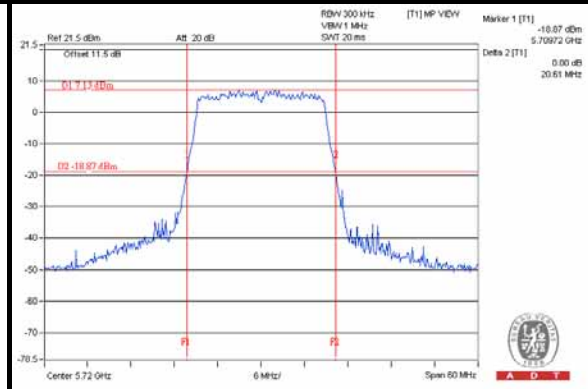

NOTE:

For CH144 (UNII-2c Band) = 5725 - Market 1

For CH144 (UNII-3 Band) = Delta 2 - CH144 (UNII-2c Band) BW



A D T

802.11ac (VHT40)

For Chain (0)

CH54

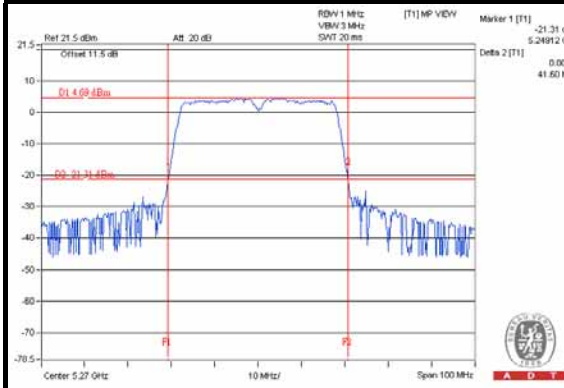

CH62

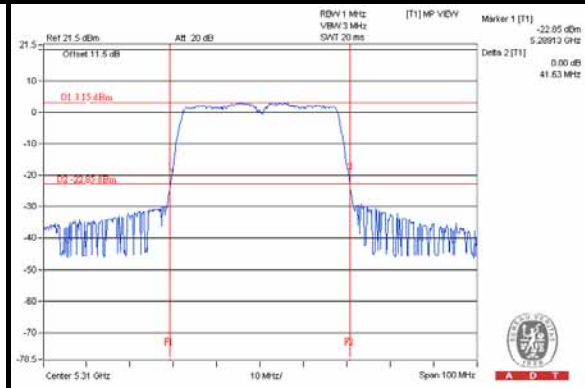

CH102

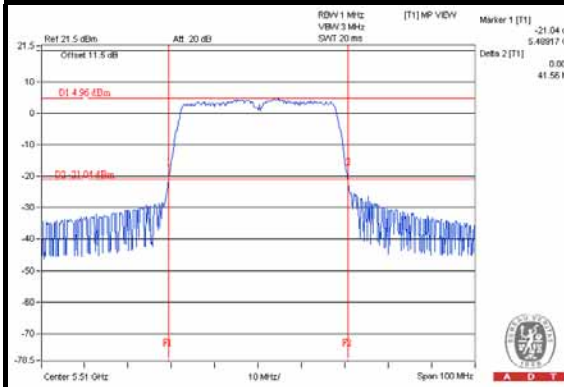

CH110

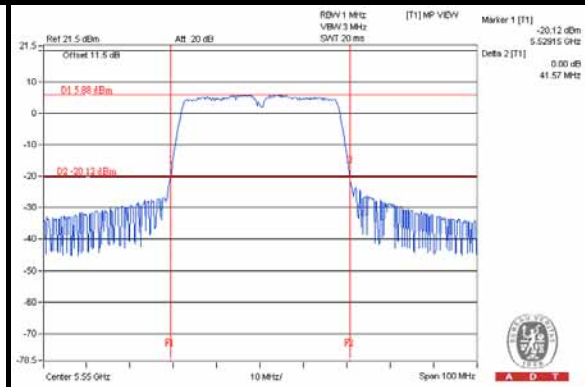

CH134

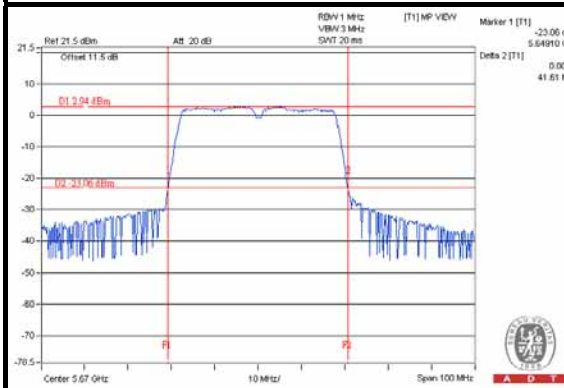

CH142 (UNII-2c Band) / CH142 (UNII-3 Band)

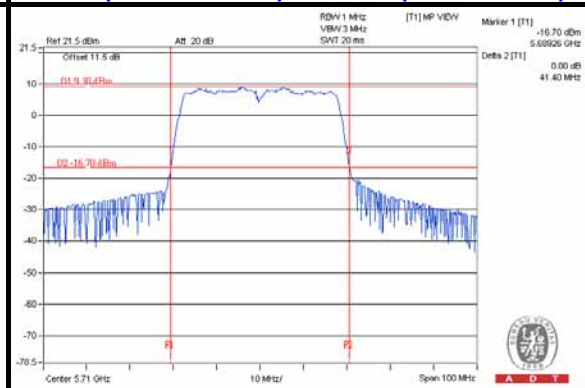

NOTE:

For CH142 (UNII-2c Band) = 5725 - Market 1

For CH142 (UNII-3 Band) = Delta 2 - CH142 (UNII-2c Band) BW



A D T

For Chain (1)

CH54

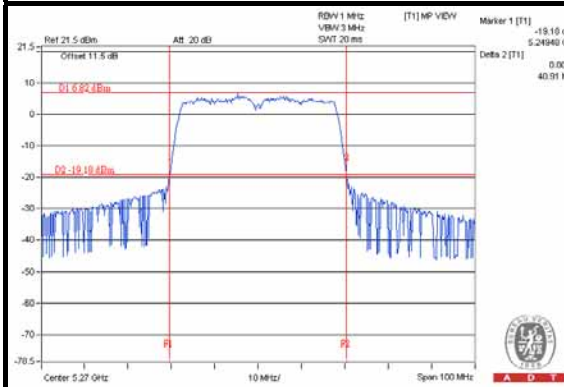

CH62

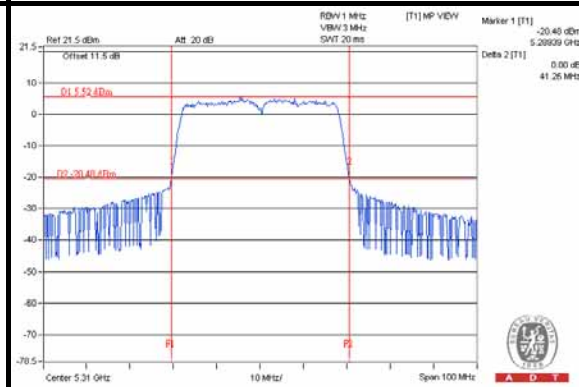

CH102

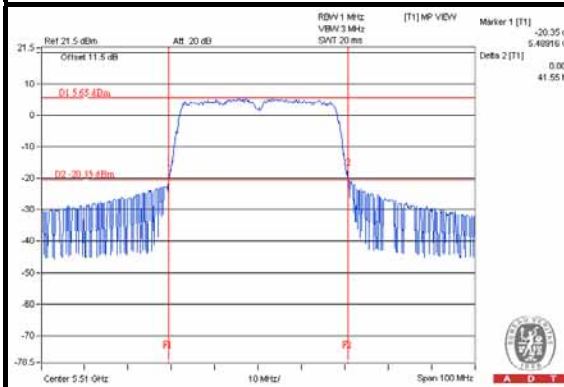

CH110

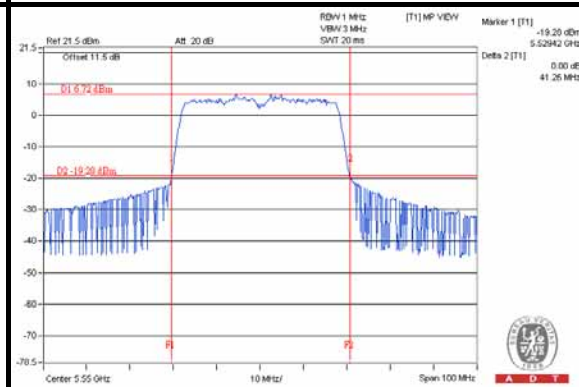

CH134

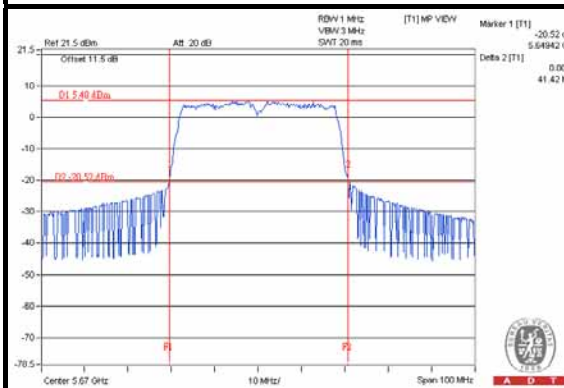

CH142 (UNII-2c Band) / CH142 (UNII-3 Band)

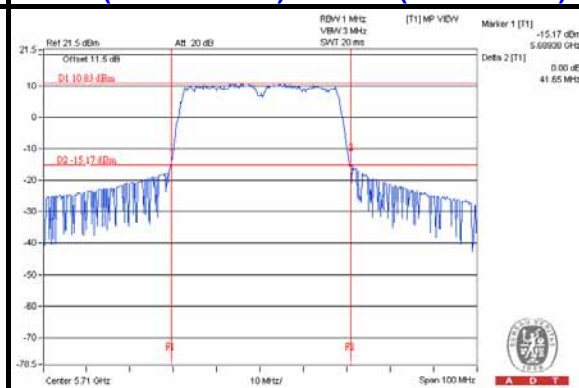

NOTE:

For CH142 (UNII-2c Band) = 5725 - Market 1

For CH142 (UNII-3 Band) = Delta 2 - CH142 (UNII-2c Band) BW



A D T

For Chain (2)

CH54

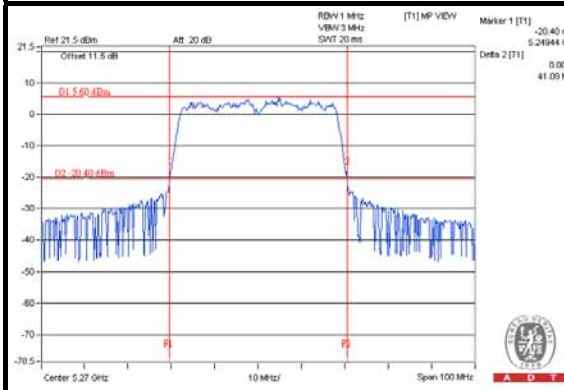

CH62

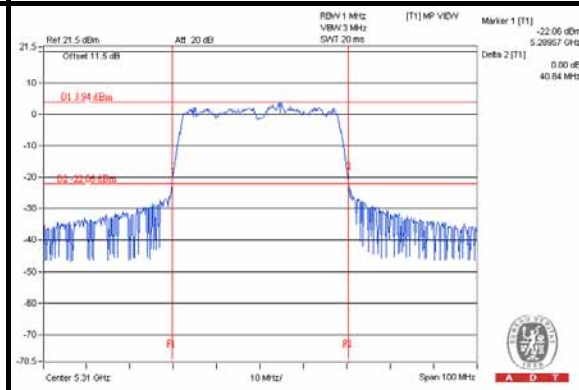

CH102

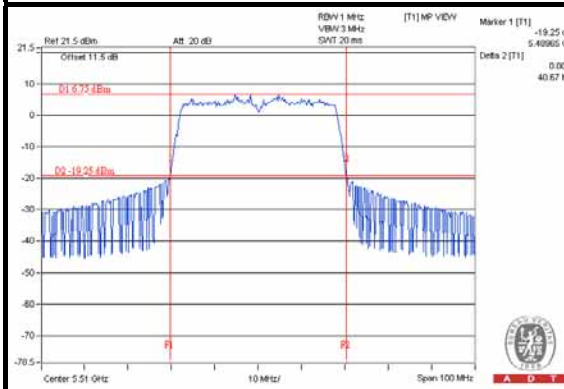

CH110

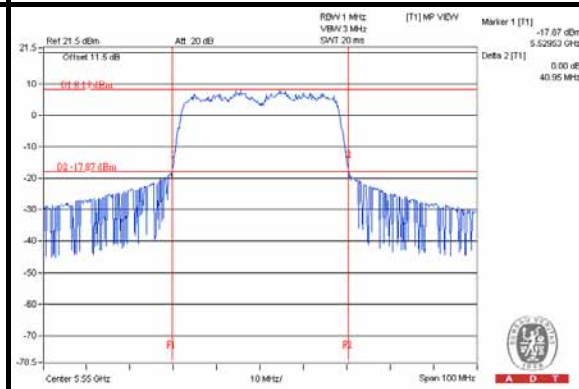

CH134

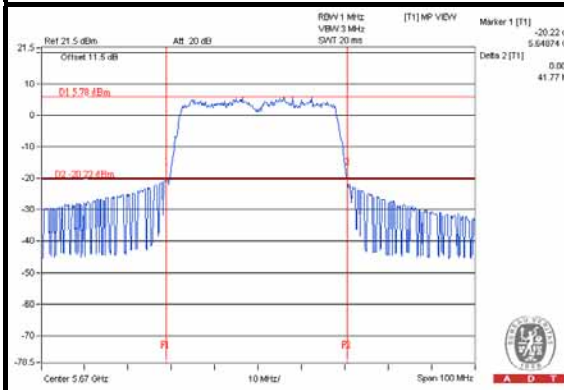

CH142 (UNII-2c Band) / CH142 (UNII-3 Band)

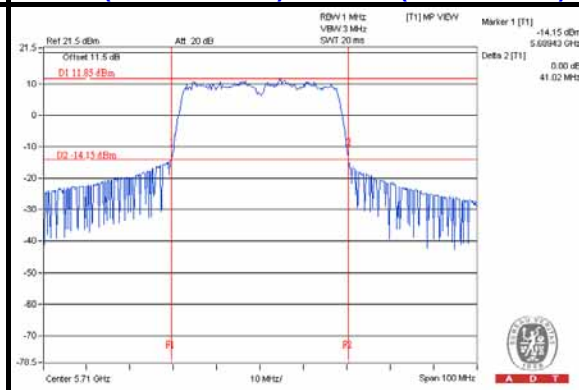

NOTE:

For CH142 (UNII-2c Band) = 5725 - Market 1

For CH142 (UNII-3 Band) = Delta 2 - CH142 (UNII-2c Band) BW



A D T

802.11ac (VHT80)

For Chain (0)

CH58

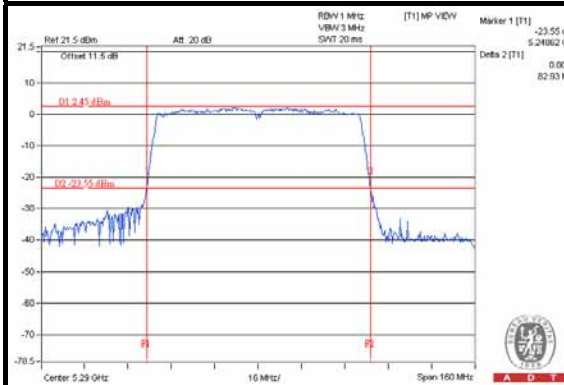

CH106

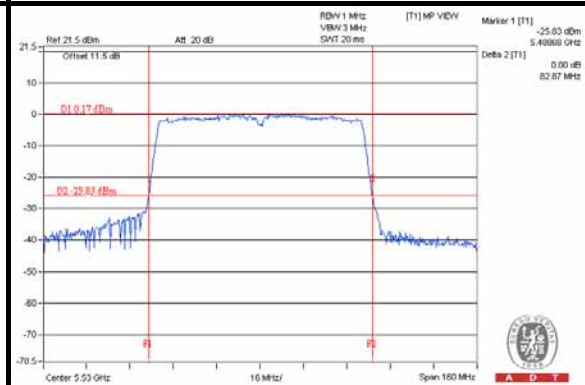

CH138 (UNII-2c Band) / CH138 (UNII-3 Band)

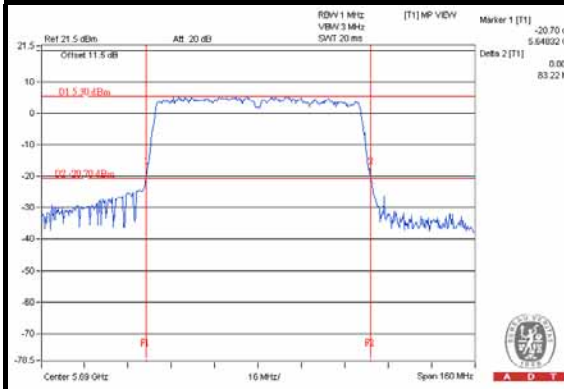

NOTE:

For CH138 (UNII-2c Band) = 5725 - Market 1

For CH138 (UNII-3 Band) = Delta 2 – CH138 (UNII-2c Band) BW



A D T

For Chain (1)

CH58

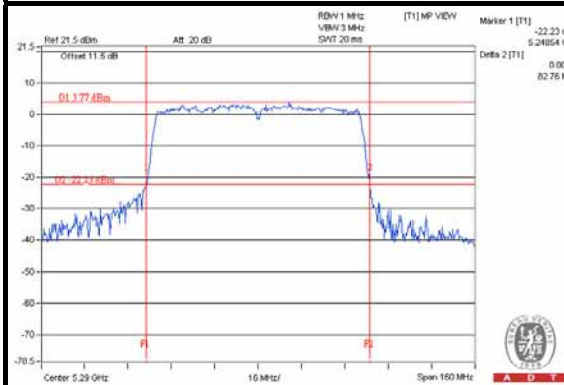

CH106

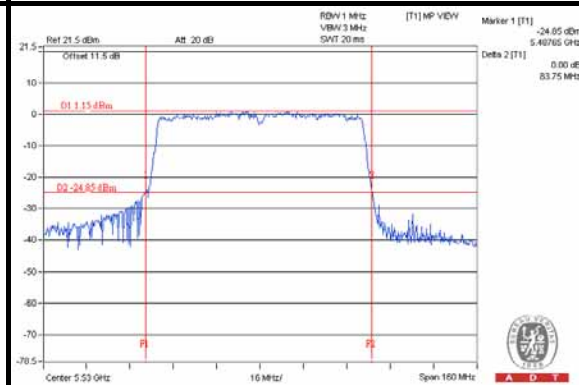

CH138 (UNII-2c Band) / CH138 (UNII-3 Band)

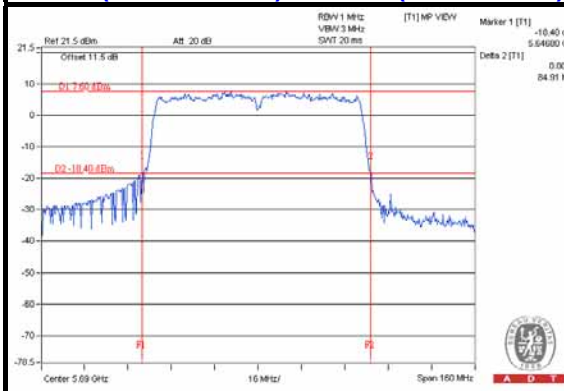

NOTE:

For CH138 (UNII-2c Band) = 5725 - Market 1

For CH138 (UNII-3 Band) = Delta 2 – CH138 (UNII-2c Band) BW



A D T

For Chain (2)

CH58

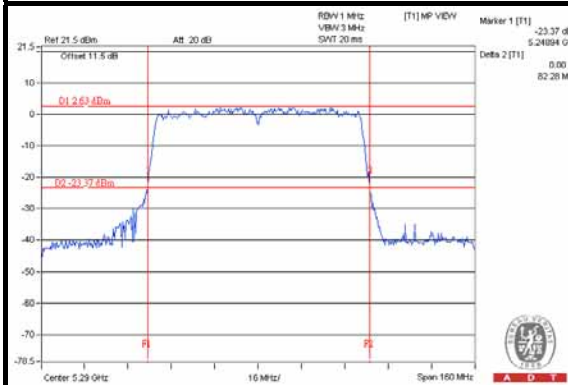

CH106

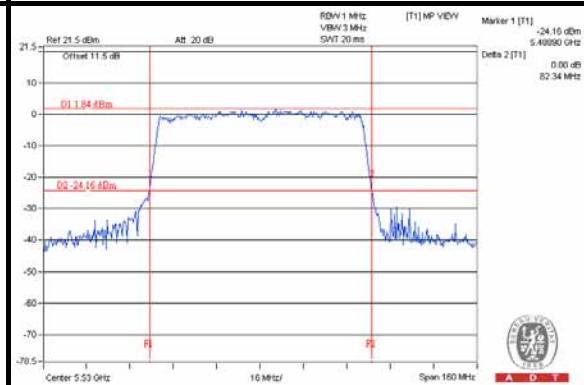

CH138 (UNII-2c Band) / CH138 (UNII-3 Band)

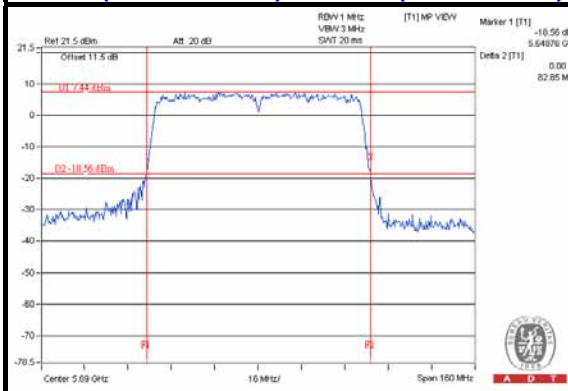

NOTE:

For CH138 (UNII-2c Band) = 5725 - Market 1

For CH138 (UNII-3 Band) = Delta 2 – CH138 (UNII-2c Band) BW



A D T

POWER OUTPUT:

Beamforming (MCS0 NSS=1)_MODE								
CHANNEL	FREQUENCY (MHz)	AVERAGE POWER (dBm)			TOTAL POWER (mW)	TOTAL POWER (dBm)	POWER LIMIT (dBm)	PASS / FAIL
		CHAIN 0	CHAIN 1	CHAIN 2				
802.11ac (VHT20)								
52	5260	6.32	8.13	4.41	13.547	11.32	20.54	PASS
60	5300	5.99	8.17	3.89	12.982	11.13	20.54	PASS
64	5320	5.98	7.87	3.69	12.426	10.94	20.54	PASS
100	5500	7.41	7.93	7.33	17.125	12.34	20.48	PASS
116	5580	11.60	12.10	11.49	44.765	16.51	20.48	PASS
132	5660	9.96	10.40	9.39	29.563	14.71	20.48	PASS
140	5700	9.56	10.02	9.03	27.080	14.33	20.48	PASS
144 (UNII-2c Band)	5720	13.03	14.07	13.31	67.047	18.26	19.32	PASS
144 (UNII-3 Band)	5720	7.12	7.97	7.86	17.527	12.44	20.74	PASS
802.11ac (VHT40)								
54	5270	10.26	11.39	9.14	32.593	15.13	20.54	PASS
62	5310	9.01	10.12	8.79	25.810	14.12	20.54	PASS
102	5510	10.15	10.63	7.62	27.693	14.42	20.48	PASS
110	5550	11.71	12.42	11.60	46.737	16.70	20.48	PASS
134	5670	10.62	11.06	10.15	34.650	15.40	20.48	PASS
142 (UNII-2c Band)	5710	11.48	12.97	12.80	52.930	17.24	20.48	PASS
142 (UNII-3 Band)	5710	1.10	2.56	2.65	4.932	6.93	20.90	PASS



A D T

802.11ac (VHT80)								
58	5290	11.01	12.17	10.12	39.38	15.95	20.54	PASS
106	5530	8.89	10.39	9.25	27.099	14.33	20.48	PASS
138 (UNII-2c Band)	5690	11.36	12.55	12.77	52.37	17.19	20.48	PASS
138 (UNII-3 Band)	5690	-2.93	-1.42	-1.05	2.0859	3.19	21.69	PASS

For CH138: Average Power (dBm)= measured value(dBm) + Duty Factor (0.15dB)

NOTE:

5250~5350MHz: Directional gain = $10 \log[(10^{G1/20} + 10^{G2/20} + 10^{G3/20})^2 / 3]$ = 9.46dBi > 6dBi , so the power limit shall be reduced to "Determined Conducted Limit-(9.46-6)".

5470~5725MHz (Except for UNII-3 Band): Directional gain = $10 \log[(10^{G1/20} + 10^{G2/20} + 10^{G3/20})^2 / 3]$ = 9.52dBi > 6dBi , so the power limit shall be reduced to "Determined Conducted Limit-(9.52-6)".

5725~5825MHz (For UNII-3 Band): Directional gain = $10 \log[(10^{G1/20} + 10^{G2/20} + 10^{G3/20})^2 / 3]$ = 9.46dBi > 6dBi , so the power limit shall be reduced to "Determined Conducted Limit-(9.46-6)".



26dB OCCUPIED BANDWIDTH:

CHANNEL	CHANNEL FREQUENCY (MHz)	26dBc BANDWIDTH (MHz)		
		CHAIN 0	CHAIN 1	CHAIN 2
802.11ac (VHT20)				
52	5260	20.65	20.52	20.52
60	5300	20.66	20.38	20.55
64	5320	20.74	20.48	20.59
100	5500	20.85	20.56	20.58
116	5580	20.79	20.54	20.52
132	5660	20.94	20.45	20.68
140	5700	20.79	20.56	20.72
144 (UNII-2c Band)	5720	15.36	15.28	15.28
144 (UNII-3 Band)	5720	5.35	5.25	5.33
802.11ac (VHT40)				
54	5270	41.60	40.91	41.09
62	5310	41.63	41.26	40.84
102	5510	41.56	41.55	40.67
110	5550	41.57	41.26	40.95
134	5670	41.61	41.42	41.77
142 (UNII-2c Band)	5710	35.74	35.62	35.57
142 (UNII-3 Band)	5710	5.66	6.03	5.45
802.11ac (VHT80)				
58	5290	82.93	82.76	82.28
106	5530	82.87	83.75	82.34
138 (UNII-2c Band)	5690	76.68	78.20	76.24
138 (UNII-3 Band)	5690	6.54	6.71	6.61

Note: For output power limitation is determined based on 26dBc bandwidth.



A D T

Power Limit = 11dBm + 10logB < UNII Band 2~3>			
Channel Number	Freq.(MHz)	Min. B(MHz)	Determined Conducted Limit (dBm)
802.11ac (VHT20)			
52	5260	20.52	24.12 > 24
60	5300	20.38	24.09 > 24
64	5320	20.48	24.11 > 24
100	5500	20.56	24.13 > 24
116	5580	20.52	24.12 > 24
132	5660	20.45	24.1 > 24
140	5700	20.56	24.13 > 24
144 (UNII-2c Band)	5720	15.28	22.84 < 24
144 (UNII-3 Band)	5720	5.25	24.2 < 30
802.11ac (VHT40)			
54	5270	40.91	27.11 > 24
62	5310	40.84	27.11 > 24
102	5510	40.67	27.09 > 24
110	5550	40.95	27.12 > 24
134	5670	41.42	27.17 > 24
142 (UNII-2c Band)	5710	35.57	26.5 > 24
142 (UNII-3 Band)	5710	5.45	24.36 < 30
802.11ac (VHT80)			
58	5290	82.28	30.15 > 24
106	5530	82.34	30.15 > 24
138 (UNII-2c Band)	5690	76.24	29.82 > 24
138 (UNII-3 Band)	5690	6.54	25.15 < 30



A D T

802.11ac (VHT20)

For Chain (0)

CH52

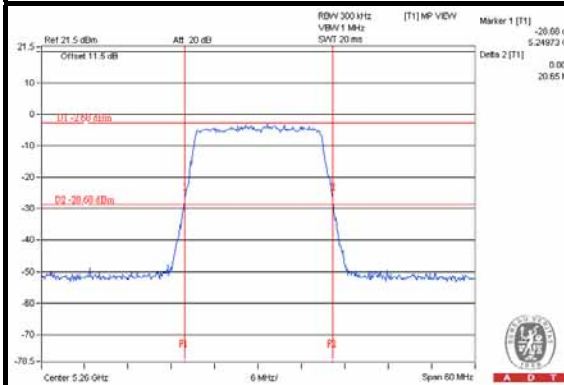

CH60

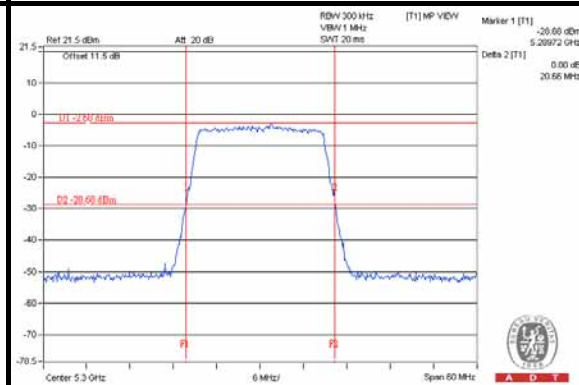

CH64

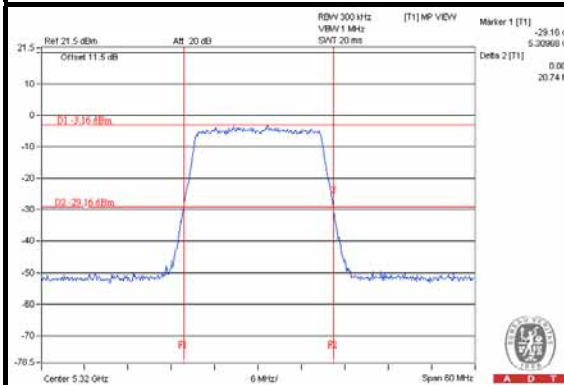

CH100

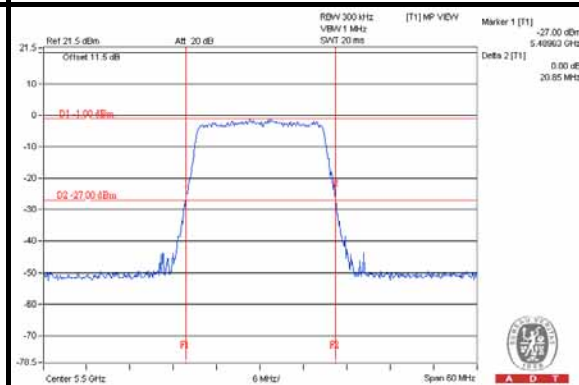

CH116

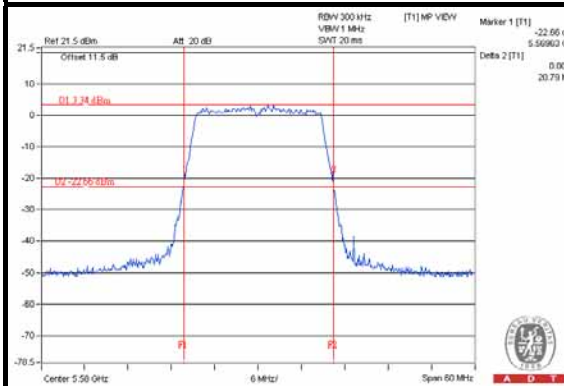

CH132

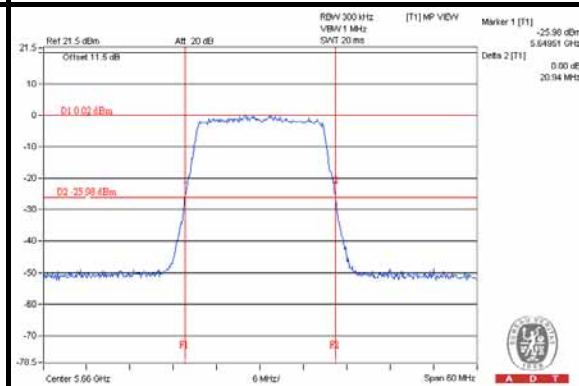



A D T

CH140

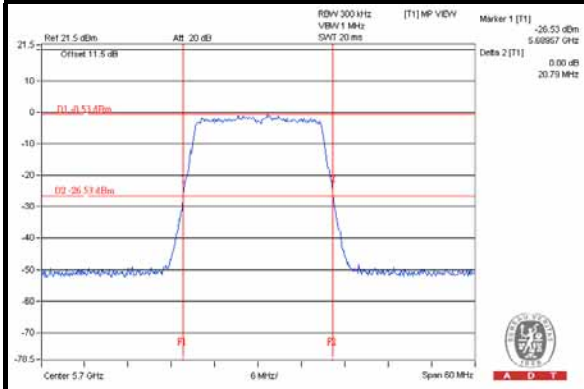

CH144 (UNII-2c Band) / CH144 (UNII-3 Band)

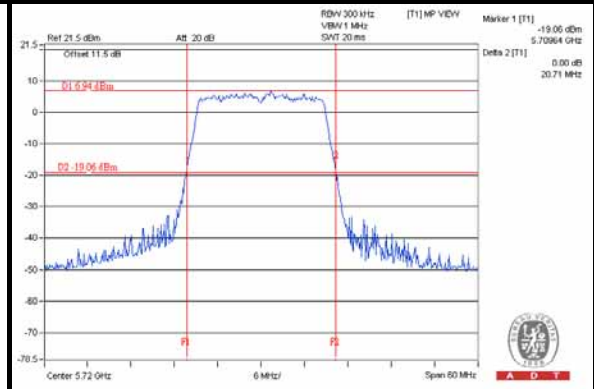

NOTE:

For CH144 (UNII-2c Band) = 5725 - Market 1

For CH144 (UNII-3 Band) = Delta 2 - CH144 (UNII-2c Band) BW



A D T

For Chain (1)

CH52

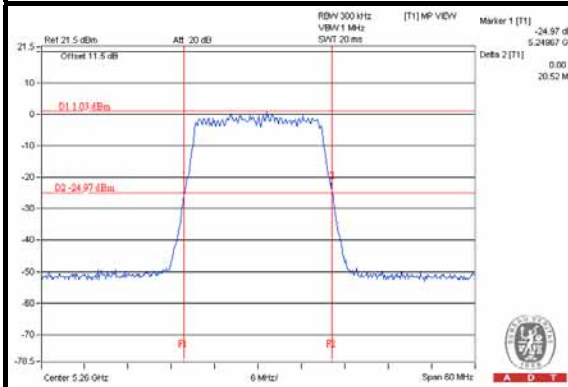

CH60

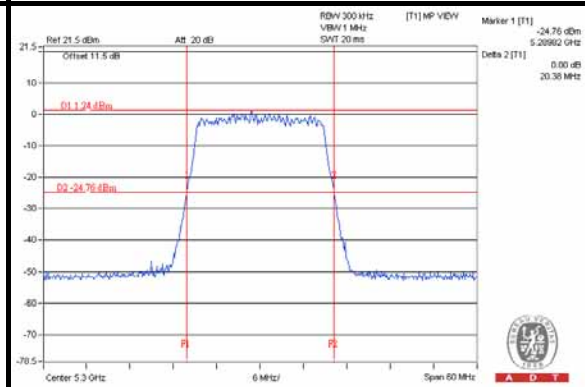

CH64

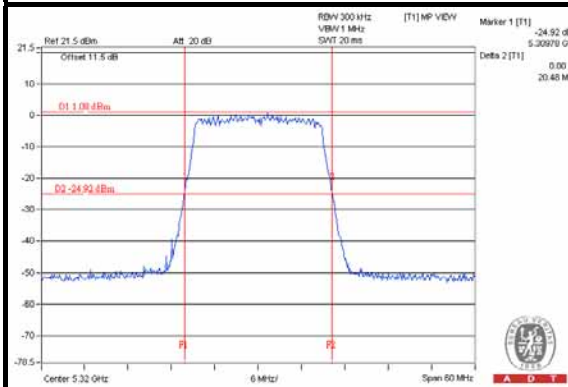

CH100

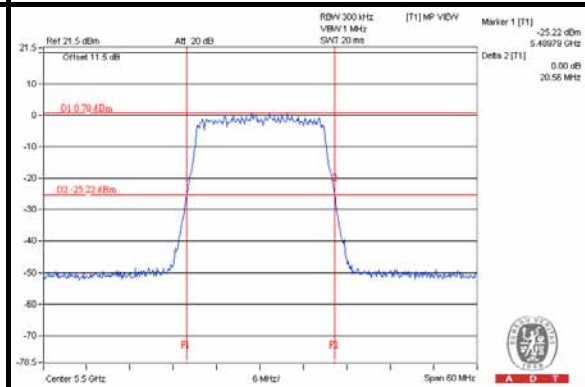

CH116

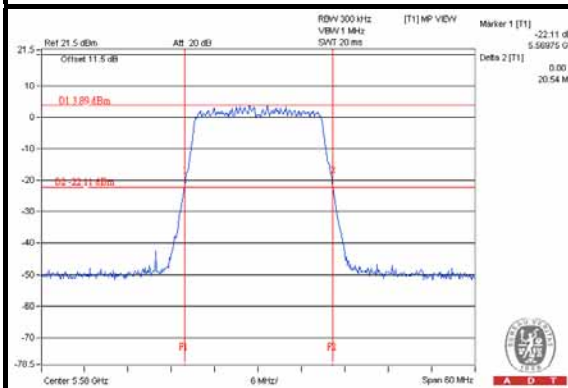

CH132

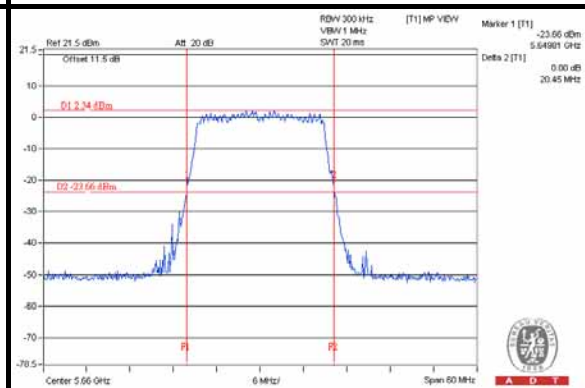



A D T

CH140

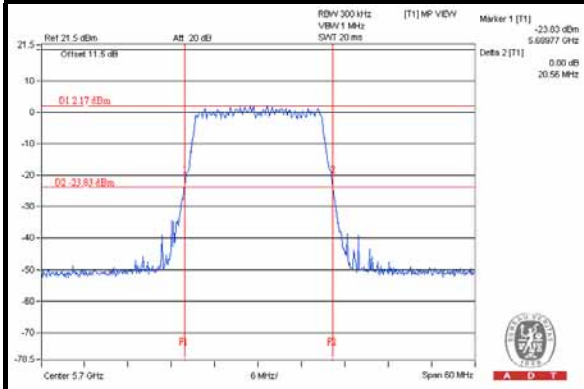

CH144 (UNII-2c Band) / CH144 (UNII-3 Band)

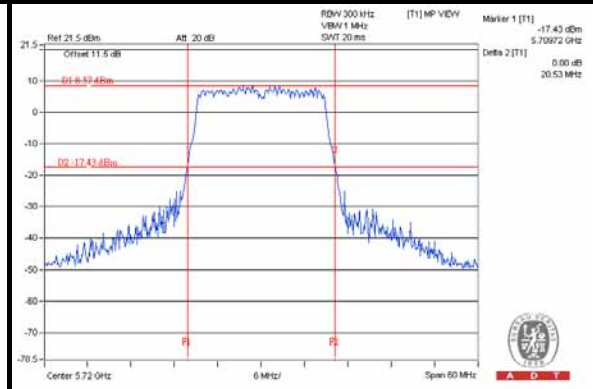

NOTE:

For CH144 (UNII-2c Band) = 5725 - Market 1

For CH144 (UNII-3 Band) = Delta 2 - CH144 (UNII-2c Band) BW



A D T

For Chain (2)

CH52

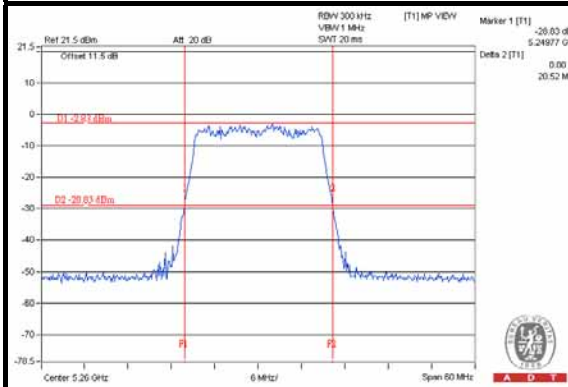

CH60

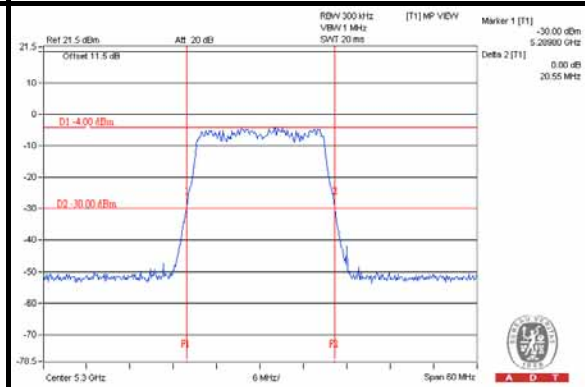

CH64

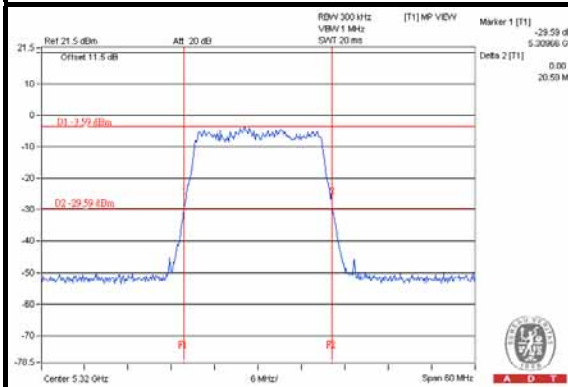

CH100

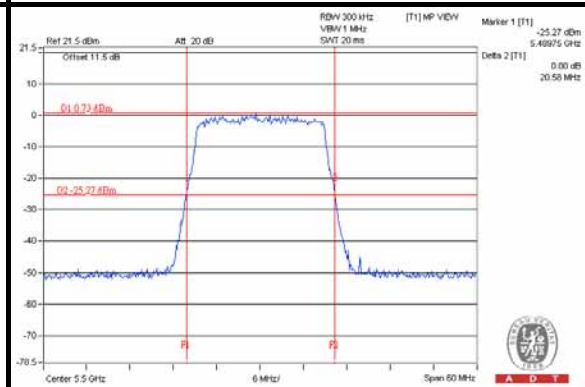

CH116

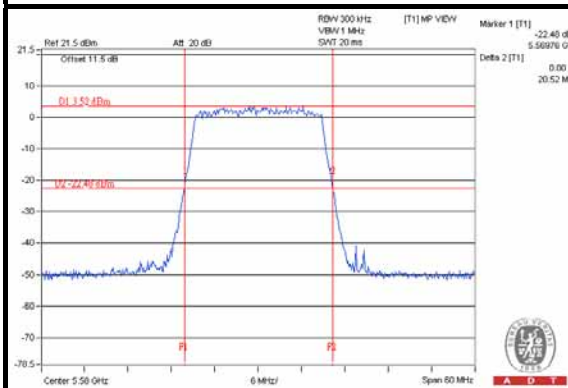

CH132

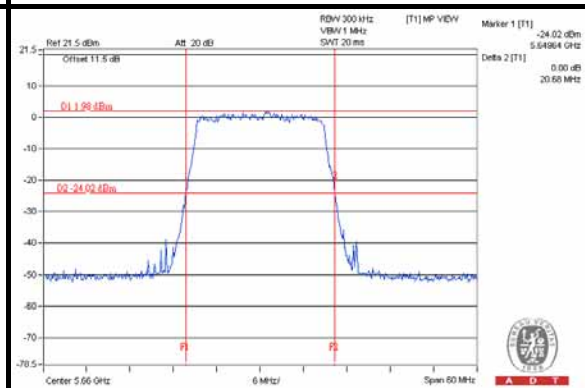



A D T

CH140

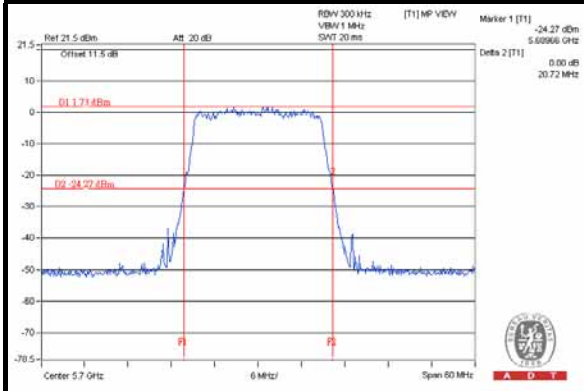

CH144 (UNII-2c Band) / CH144 (UNII-3 Band)

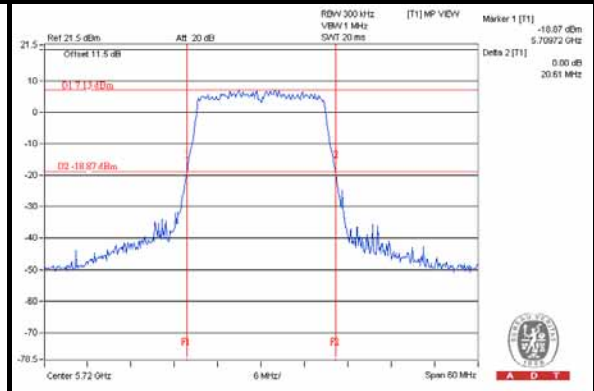

NOTE:

For CH144 (UNII-2c Band) = 5725 - Market 1

For CH144 (UNII-3 Band) = Delta 2 - CH144 (UNII-2c Band) BW



A D T

802.11ac (VHT40)

For Chain (0)

CH54

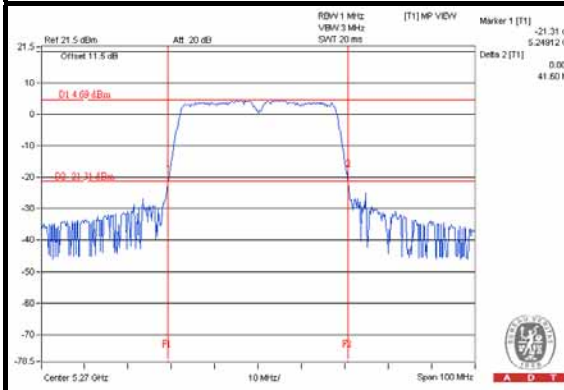

CH62

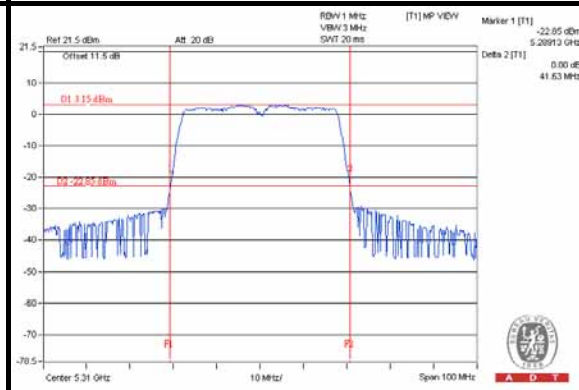

CH102

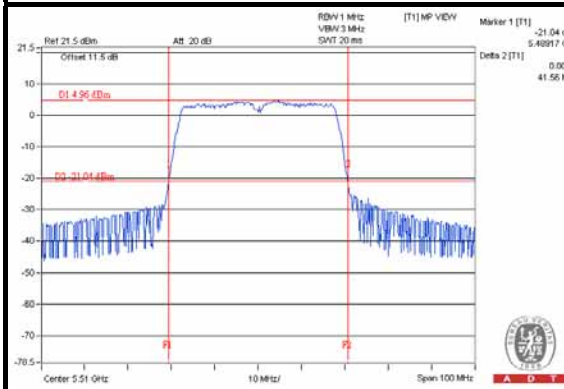

CH110

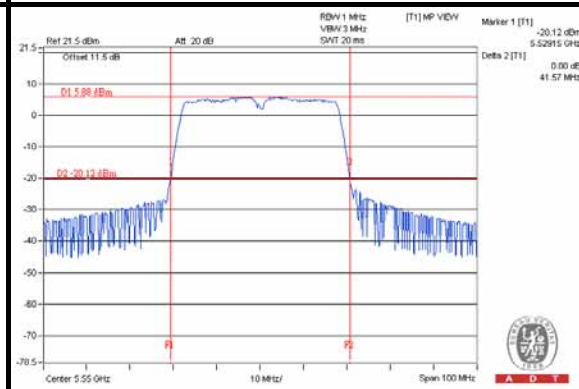

CH134

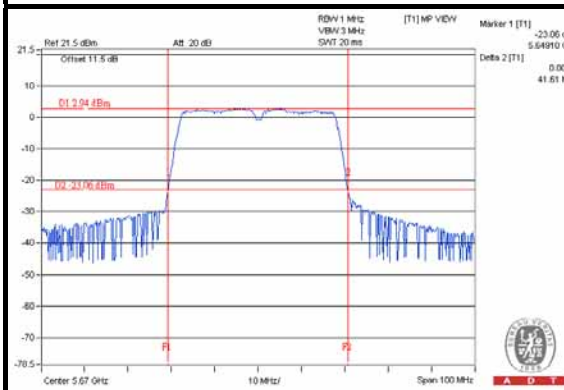

CH142 (UNII-2c Band) / CH142 (UNII-3 Band)

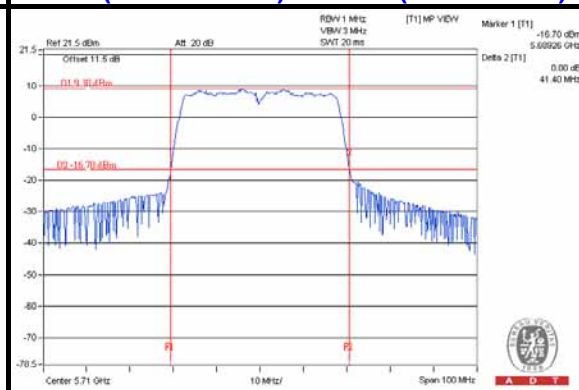

NOTE:

For CH142 (UNII-2c Band) = 5725 - Market 1

For CH142 (UNII-3 Band) = Delta 2 - CH142 (UNII-2c Band) BW



A D T

For Chain (1)

CH54

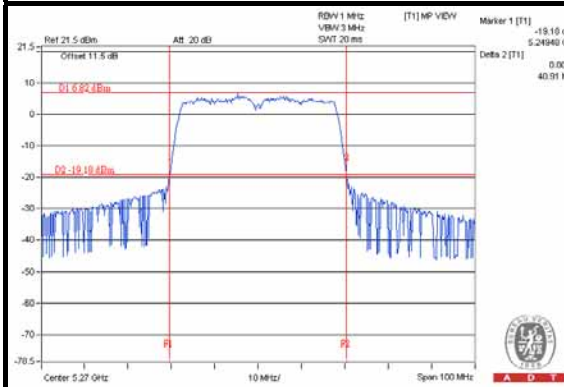

CH62

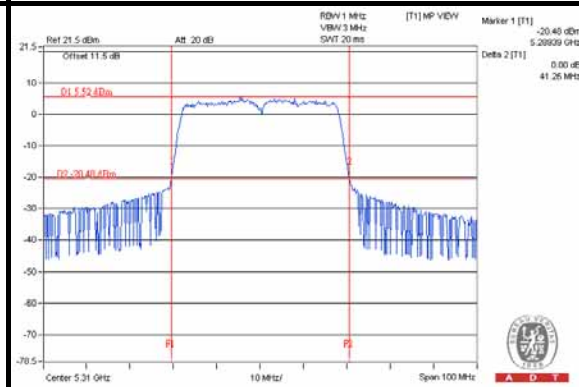

CH102

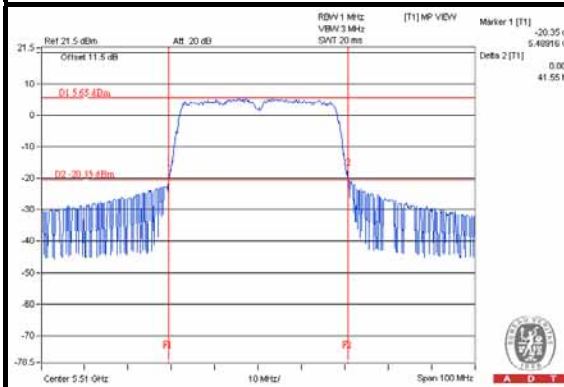

CH110

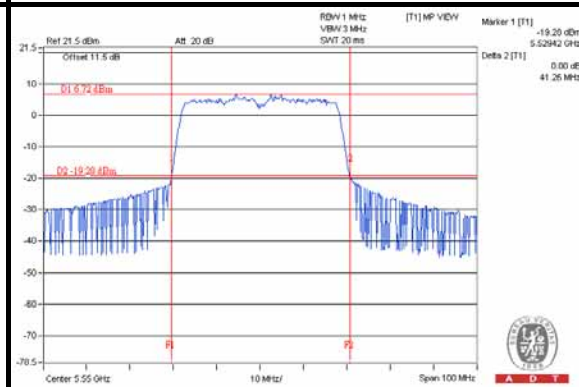

CH134

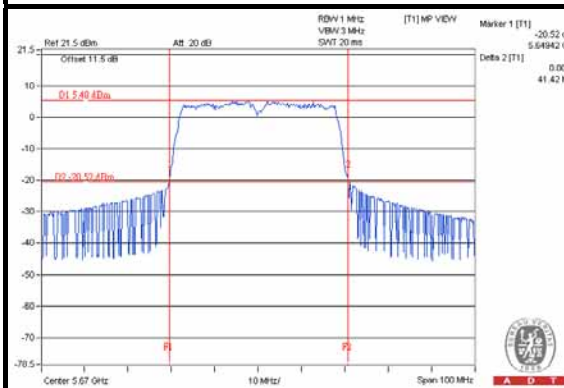

CH142 (UNII-2c Band) / CH142 (UNII-3 Band)

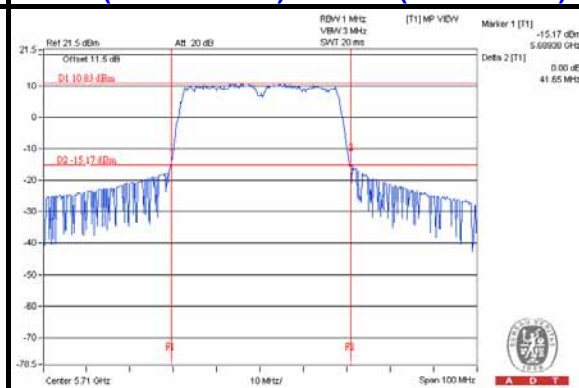

NOTE:

For CH142 (UNII-2c Band) = 5725 - Market 1

For CH142 (UNII-3 Band) = Delta 2 - CH142 (UNII-2c Band) BW



A D T

For Chain (2)

CH54

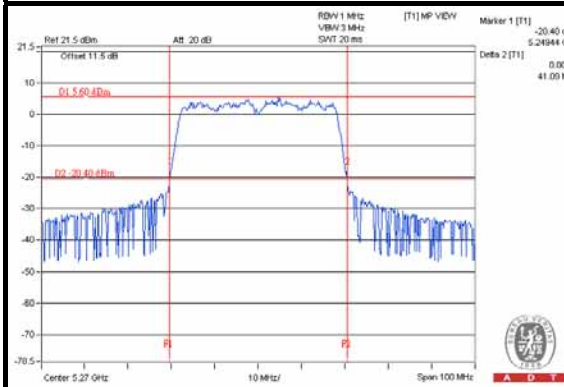

CH62

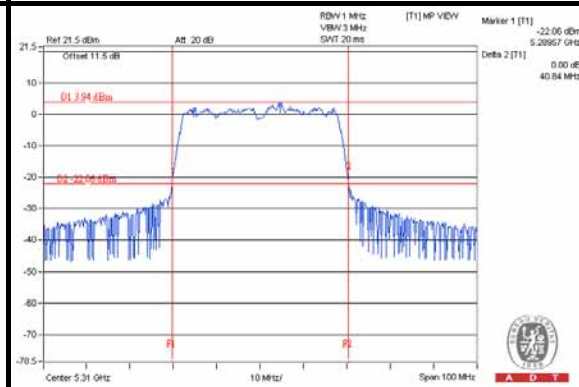

CH102

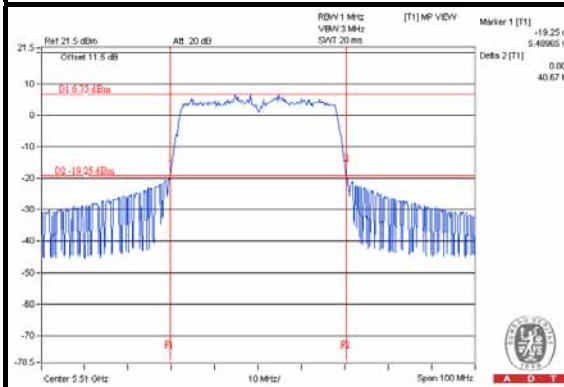

CH110

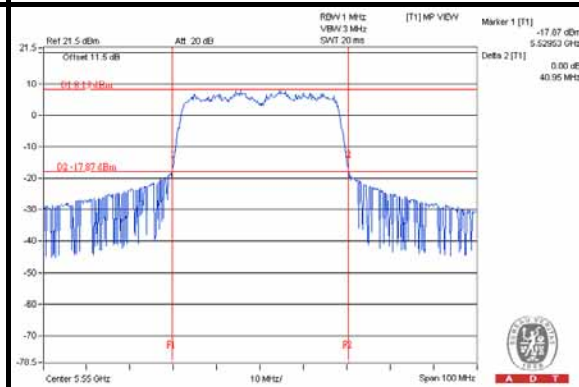

CH134

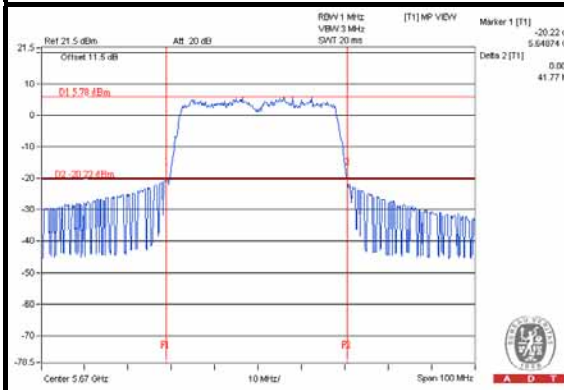

CH142 (UNII-2c Band) / CH142 (UNII-3 Band)

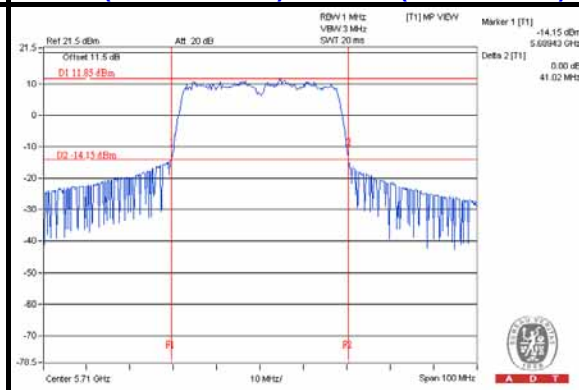

NOTE:

For CH142 (UNII-2c Band) = 5725 - Market 1

For CH142 (UNII-3 Band) = Delta 2 - CH142 (UNII-2c Band) BW



A D T

802.11ac (VHT80)

For Chain (0)

CH58

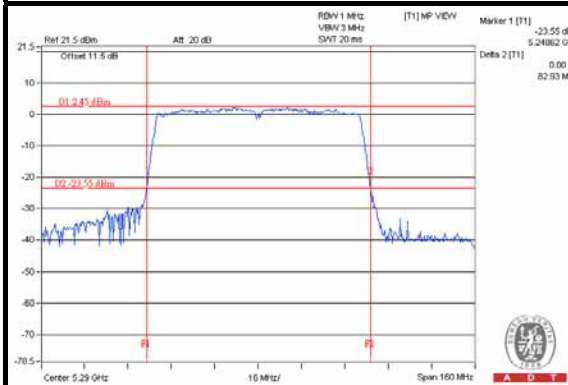

CH106

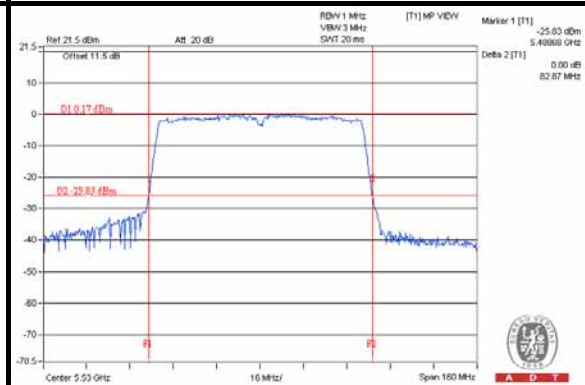

CH138 (UNII-2c Band) / CH138 (UNII-3 Band)

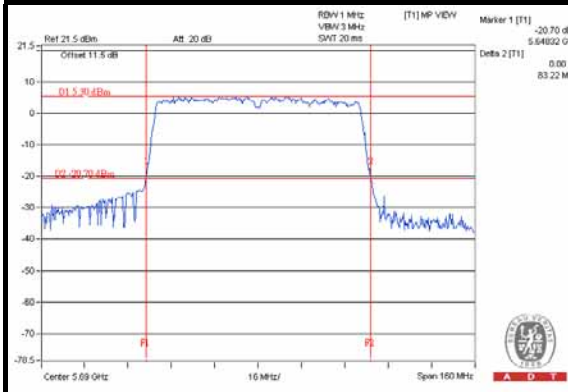

NOTE:

For CH138 (UNII-2c Band) = 5725 - Market 1

For CH138 (UNII-3 Band) = Delta 2 – CH138 (UNII-2c Band) BW



A D T

For Chain (1)

CH58

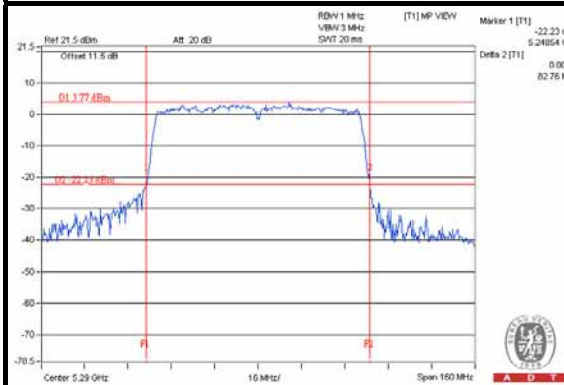

CH106

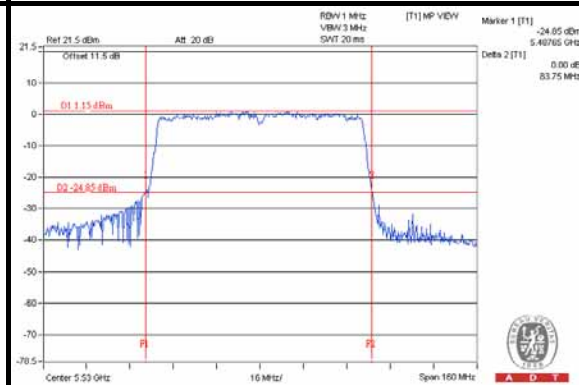

CH138 (UNII-2c Band) / CH138 (UNII-3 Band)

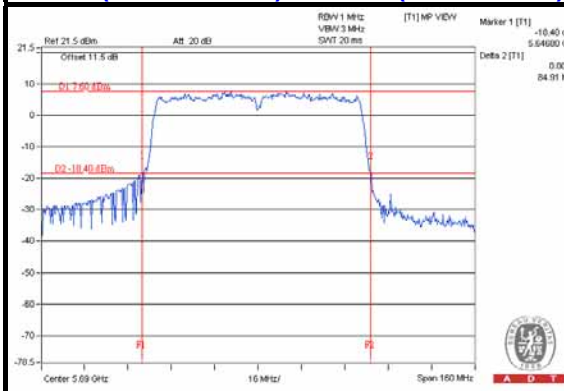

NOTE:

For CH138 (UNII-2c Band) = 5725 - Market 1

For CH138 (UNII-3 Band) = Delta 2 – CH138 (UNII-2c Band) BW



A D T

For Chain (2)

CH58

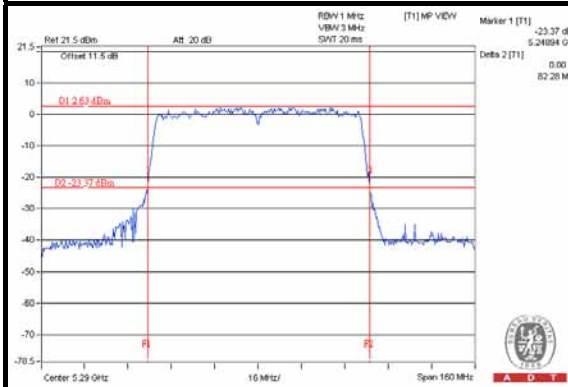

CH106

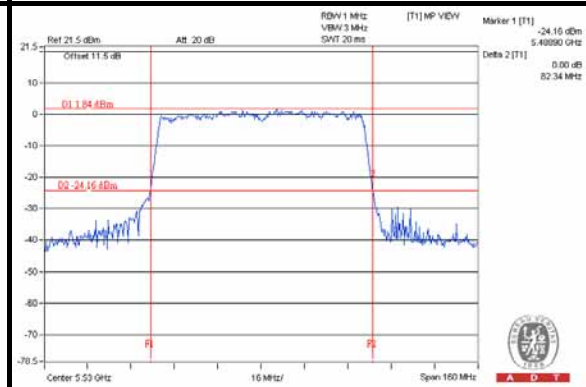

CH138 (UNII-2c Band) / CH138 (UNII-3 Band)

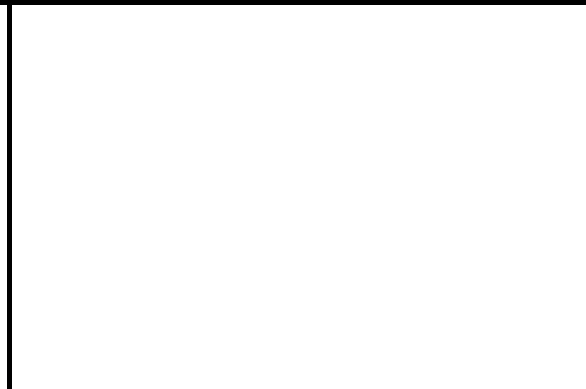
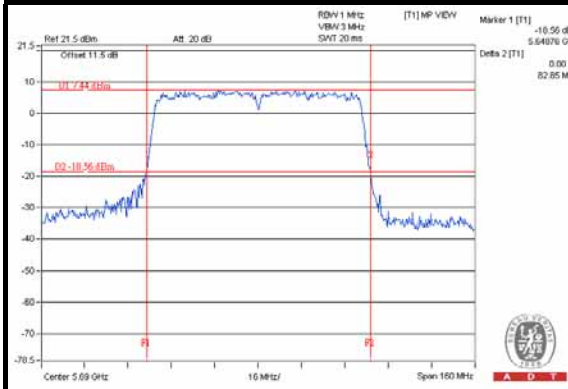

NOTE:

For CH138 (UNII-2c Band) = 5725 - Market 1

For CH138 (UNII-3 Band) = Delta 2 – CH138 (UNII-2c Band) BW



A D T

POWER OUTPUT:

Beamforming (MCS0 NSS=2)_MODE								
CHANNEL	FREQUENCY (MHz)	AVERAGE POWER (dBm)			TOTAL POWER (mW)	TOTAL POWER (dBm)	POWER LIMIT (dBm)	PASS / FAIL
		CHAIN 0	CHAIN 1	CHAIN 2				
802.11ac (VHT20)								
52	5260	6.32	8.13	4.41	13.547	11.32	22.49	PASS
60	5300	5.99	8.17	3.89	12.982	11.13	22.49	PASS
64	5320	5.98	7.87	3.69	12.426	10.94	22.49	PASS
100	5500	7.41	7.93	7.33	17.125	12.34	22.49	PASS
116	5580	11.60	12.10	11.49	44.765	16.51	22.49	PASS
132	5660	9.96	10.40	9.39	29.563	14.71	22.49	PASS
140	5700	9.56	10.02	9.03	27.080	14.33	22.49	PASS
144 (UNII-2c Band)	5720	13.03	14.07	13.31	67.047	18.26	21.33	PASS
144 (UNII-3 Band)	5720	7.12	7.97	7.86	17.527	12.44	22.73	PASS
802.11ac (VHT40)								
54	5270	10.26	11.39	9.14	32.593	15.13	22.49	PASS
62	5310	9.01	10.12	8.79	25.810	14.12	22.49	PASS
102	5510	10.15	10.63	7.62	27.693	14.42	22.49	PASS
110	5550	11.71	12.42	11.60	46.737	16.70	22.49	PASS
134	5670	10.62	11.06	10.15	34.650	15.40	22.49	PASS
142 (UNII-2c Band)	5710	11.48	12.97	12.80	52.930	17.24	22.49	PASS
142 (UNII-3 Band)	5710	1.10	2.56	2.65	4.932	6.93	22.89	PASS



A D T

802.11ac (VHT80)								
58	5290	11.01	12.17	10.12	39.38	15.95	22.49	PASS
106	5530	8.89	10.39	9.25	27.099	14.33	22.49	PASS
138 (UNII-2c Band)	5690	11.36	12.55	12.77	52.37	17.19	22.49	PASS
138 (UNII-3 Band)	5690	-2.93	-1.42	-1.05	2.0859	3.19	23.68	PASS

For CH138: Average Power (dBm)= measured value(dBm) + Duty Factor (0.15dB)

NOTE:

5250~5350MHz: Directional gain = maximum gain of antennas + $10 \log(3/2) = 7.51\text{dBi} > 6\text{dBi}$, so the power limit shall be reduced to "Determined Conducted Limit-(7.51-6)".

5470~5725MHz (Except for UNII-3 Band): Directional gain = maximum gain of antennas + $10 \log(3/2) = 7.51\text{dBi} > 6\text{dBi}$, so the power limit shall be reduced to "Determined Conducted Limit-(7.51-6)".

5725~5825MHz (For UNII-3 Band): Directional gain = maximum gain of antennas + $10 \log(3/2) = 7.47\text{dBi} > 6\text{dBi}$, so the power limit shall be reduced to "Determined Conducted Limit-(7.47-6)".



A D T

26dB OCCUPIED BANDWIDTH:

CHANNEL	CHANNEL FREQUENCY (MHz)	26dBc BANDWIDTH (MHz)		
		CHAIN 0	CHAIN 1	CHAIN 2
802.11ac (VHT20)				
52	5260	20.65	20.52	20.52
60	5300	20.66	20.38	20.55
64	5320	20.74	20.48	20.59
100	5500	20.85	20.56	20.58
116	5580	20.79	20.54	20.52
132	5660	20.94	20.45	20.68
140	5700	20.79	20.56	20.72
144 (UNII-2c Band)	5720	15.36	15.28	15.28
144 (UNII-3 Band)	5720	5.35	5.25	5.33
802.11ac (VHT40)				
54	5270	41.60	40.91	41.09
62	5310	41.63	41.26	40.84
102	5510	41.56	41.55	40.67
110	5550	41.57	41.26	40.95
134	5670	41.61	41.42	41.77
142 (UNII-2c Band)	5710	35.74	35.62	35.57
142 (UNII-3 Band)	5710	5.66	6.03	5.45
802.11ac (VHT80)				
58	5290	82.93	82.76	82.28
106	5530	82.87	83.75	82.34
138 (UNII-2c Band)	5690	76.68	78.20	76.24
138 (UNII-3 Band)	5690	6.54	6.71	6.61

Note: For output power limitation is determined based on 26dBc bandwidth.



A D T

Power Limit = 11dBm + 10logB < UNII Band 2~3>			
Channel Number	Freq.(MHz)	Min. B(MHz)	Determined Conducted Limit (dBm)
802.11ac (VHT20)			
52	5260	20.52	24.12 > 24
60	5300	20.38	24.09 > 24
64	5320	20.48	24.11 > 24
100	5500	20.56	24.13 > 24
116	5580	20.52	24.12 > 24
132	5660	20.45	24.1 > 24
140	5700	20.56	24.13 > 24
144 (UNII-2c Band)	5720	15.28	22.84 < 24
144 (UNII-3 Band)	5720	5.25	24.2 < 30
802.11ac (VHT40)			
54	5270	40.91	27.11 > 24
62	5310	40.84	27.11 > 24
102	5510	40.67	27.09 > 24
110	5550	40.95	27.12 > 24
134	5670	41.42	27.17 > 24
142 (UNII-2c Band)	5710	35.57	26.5 > 24
142 (UNII-3 Band)	5710	5.45	24.36 < 30
802.11ac (VHT80)			
58	5290	82.28	30.15 > 24
106	5530	82.34	30.15 > 24
138 (UNII-2c Band)	5690	76.24	29.82 > 24
138 (UNII-3 Band)	5690	6.54	25.15 < 30



A D T

802.11ac (VHT20)

For Chain (0)

CH52

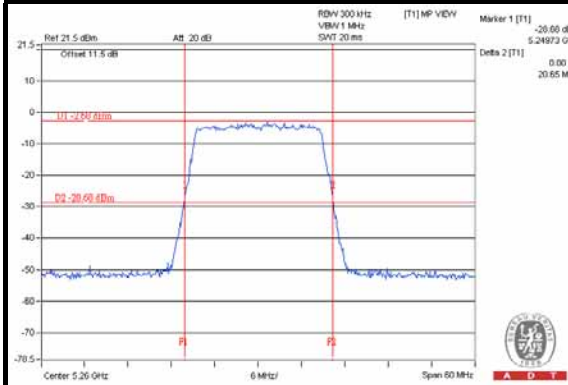

CH60

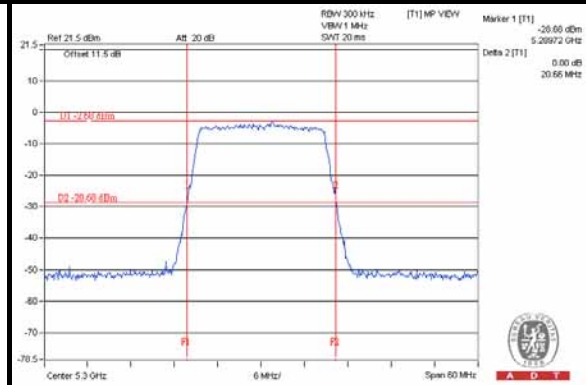

CH64

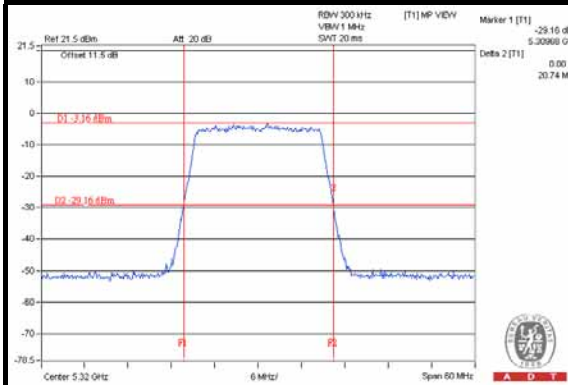

CH100

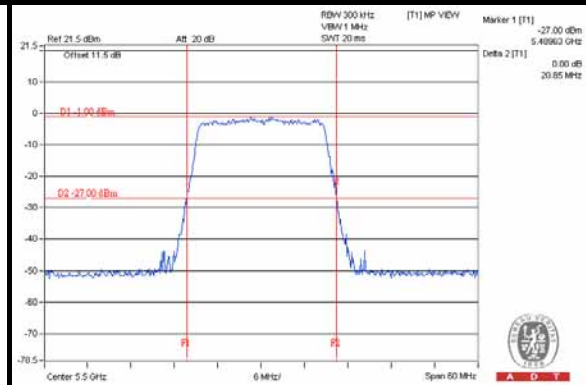

CH116

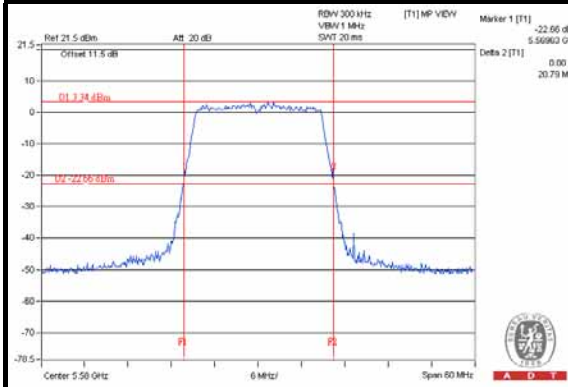

CH132

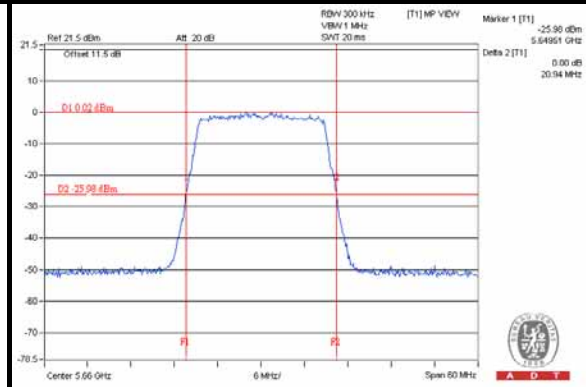



A D T

CH140

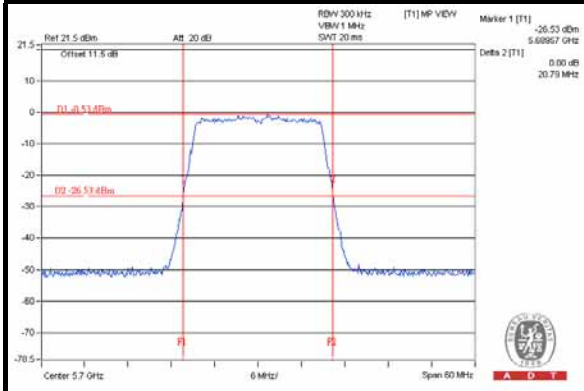

CH144 (UNII-2c Band) / CH144 (UNII-3 Band)

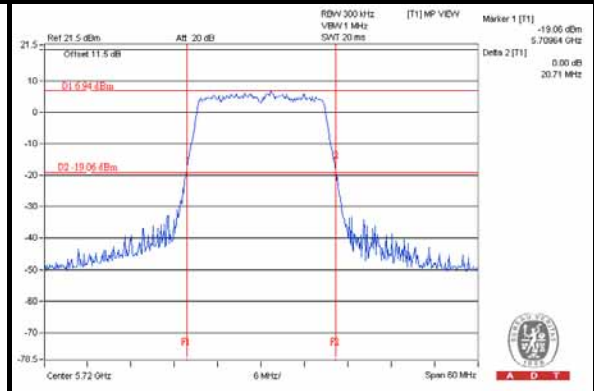

NOTE:

For CH144 (UNII-2c Band) = 5725 - Market 1

For CH144 (UNII-3 Band) = Delta 2 - CH144 (UNII-2c Band) BW



A D T

For Chain (1)

CH52

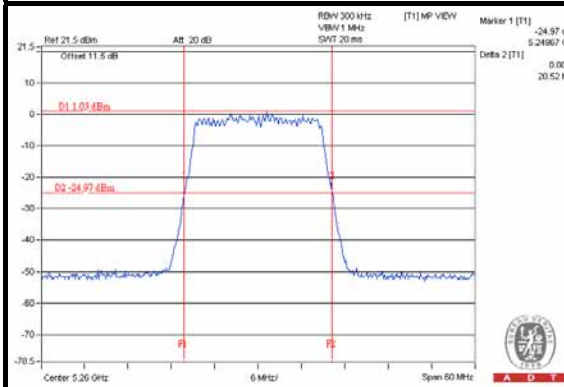

CH60

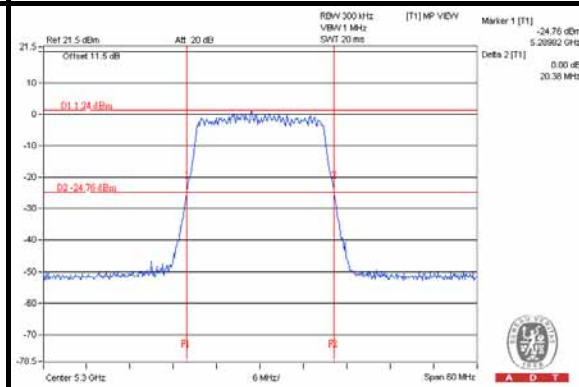

CH64

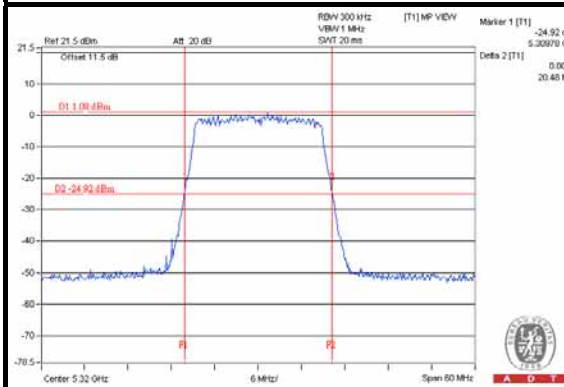

CH100

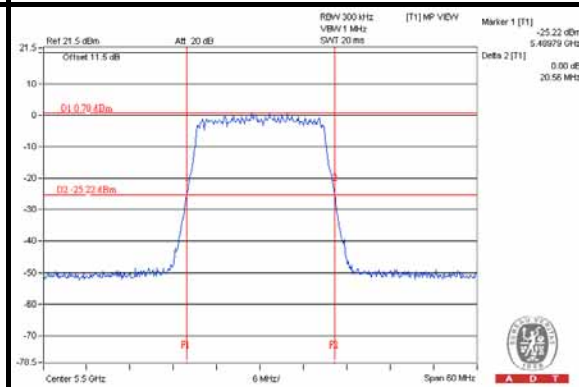

CH116

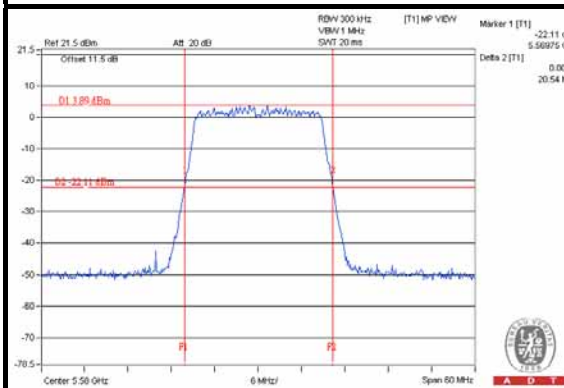

CH132

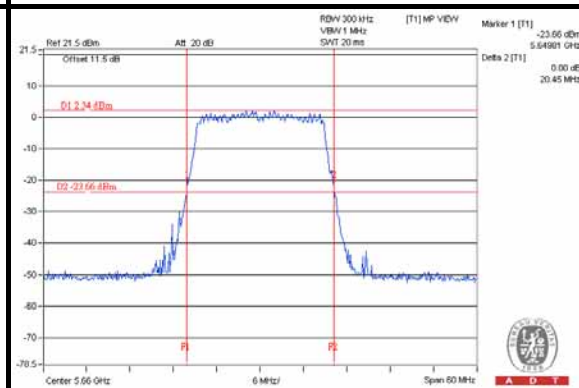



A D T

CH140

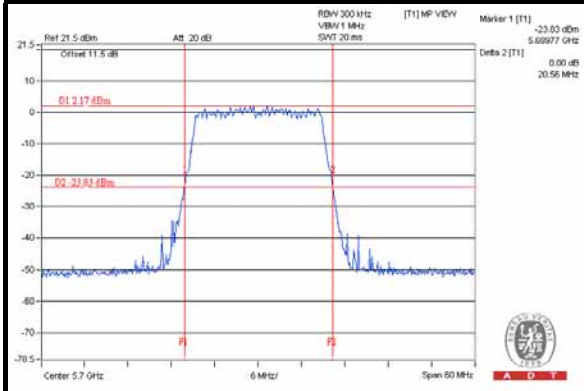

CH144 (UNII-2c Band) / CH144 (UNII-3 Band)

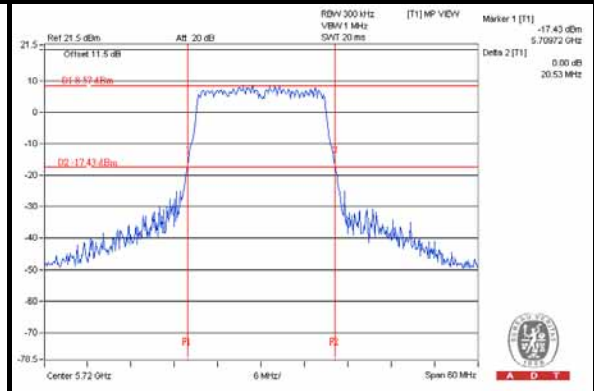

NOTE:

For CH144 (UNII-2c Band) = 5725 - Market 1

For CH144 (UNII-3 Band) = Delta 2 - CH144 (UNII-2c Band) BW



A D T

For Chain (2)

CH52

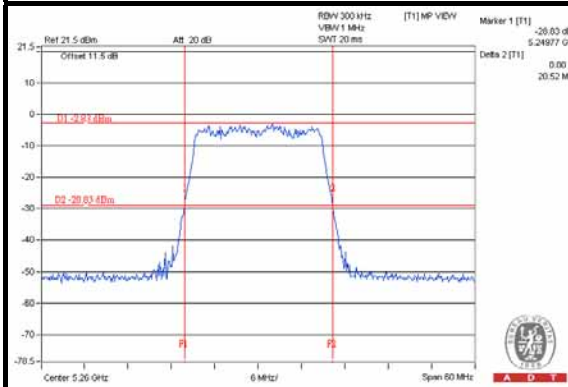

CH60

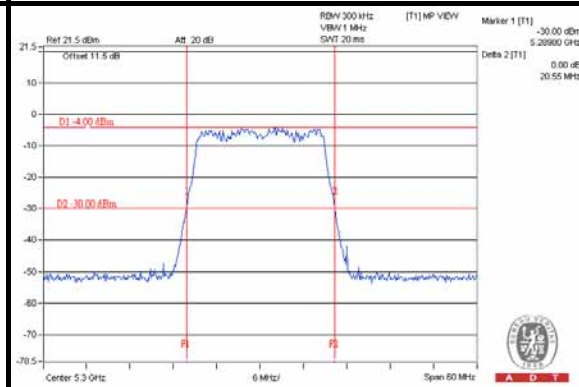

CH64

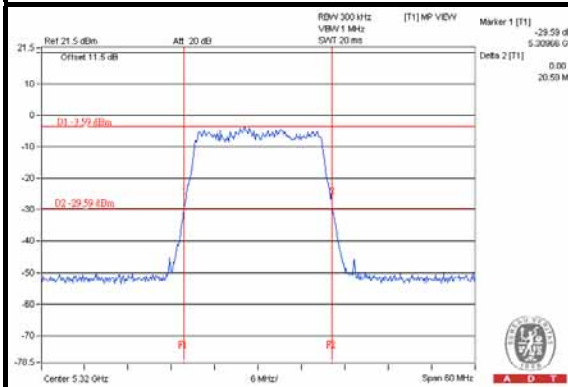

CH100

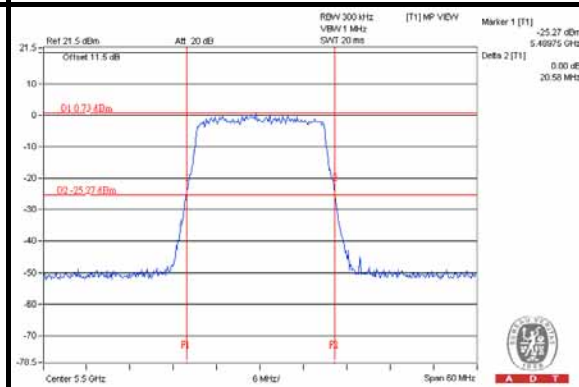

CH116

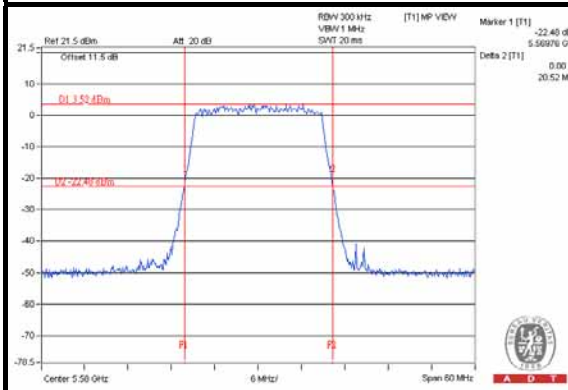

CH132

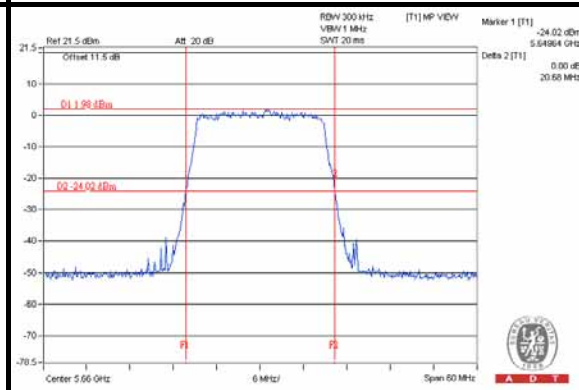



A D T

CH140

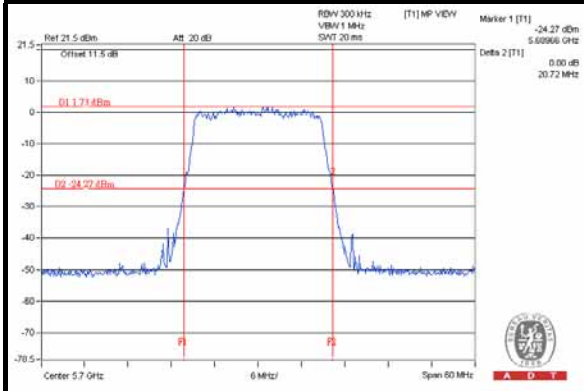

CH144 (UNII-2c Band) / CH144 (UNII-3 Band)

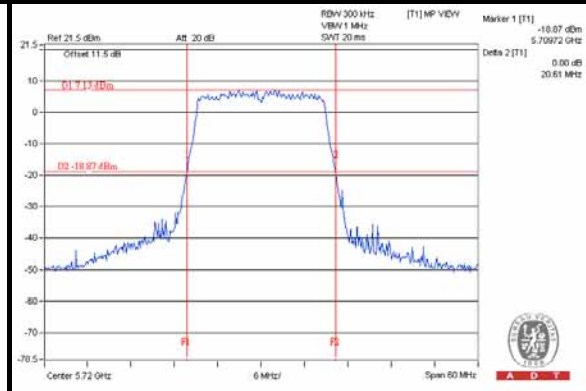

NOTE:

For CH144 (UNII-2c Band) = 5725 - Market 1

For CH144 (UNII-3 Band) = Delta 2 - CH144 (UNII-2c Band) BW



A D T

802.11ac (VHT40)

For Chain (0)

CH54

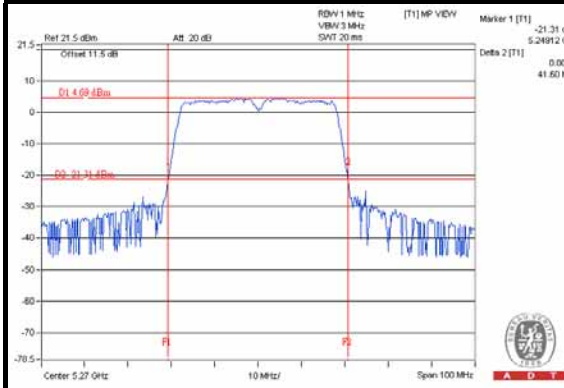

CH62

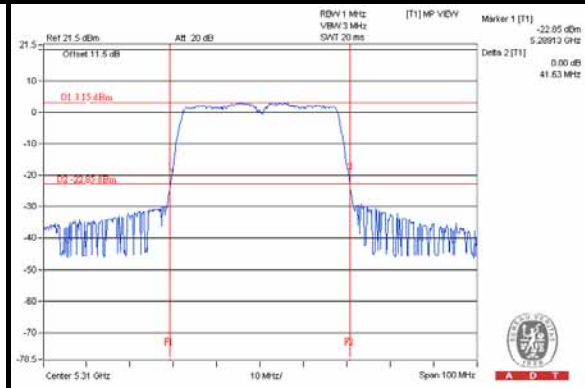

CH102

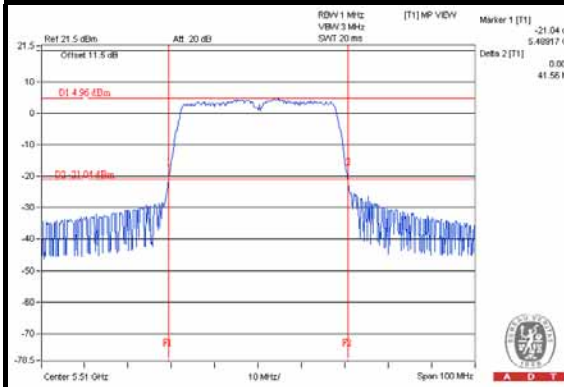

CH110

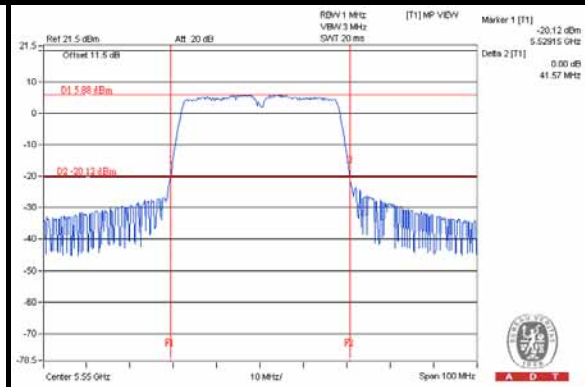

CH134

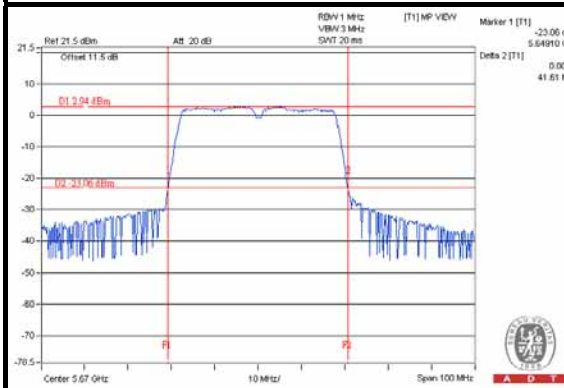

CH142 (UNII-2c Band) / CH142 (UNII-3 Band)

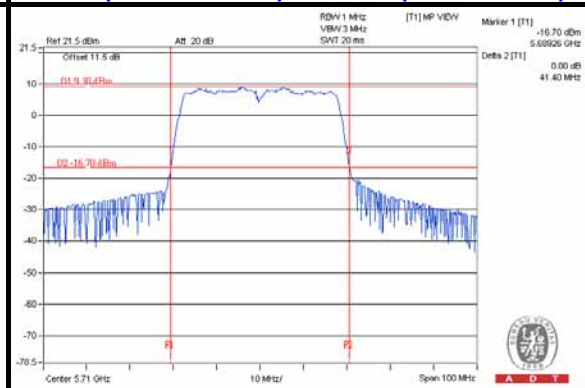

NOTE:

For CH142 (UNII-2c Band) = 5725 - Market 1

For CH142 (UNII-3 Band) = Delta 2 - CH142 (UNII-2c Band) BW



A D T

For Chain (1)

CH54

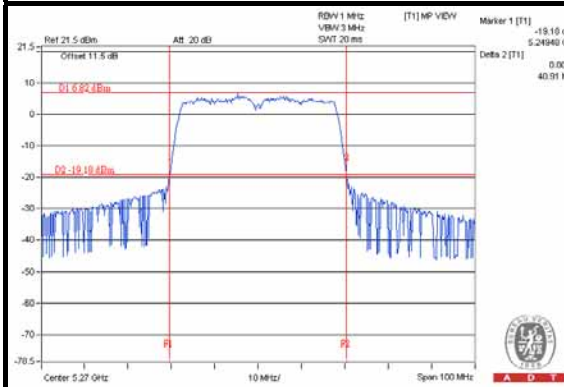

CH62

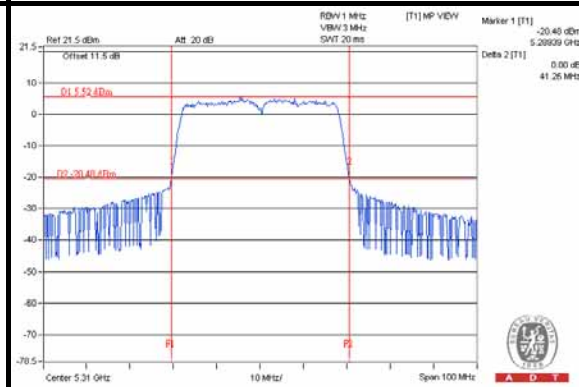

CH102

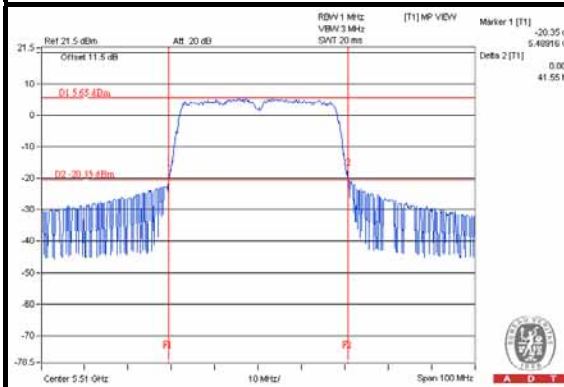

CH110

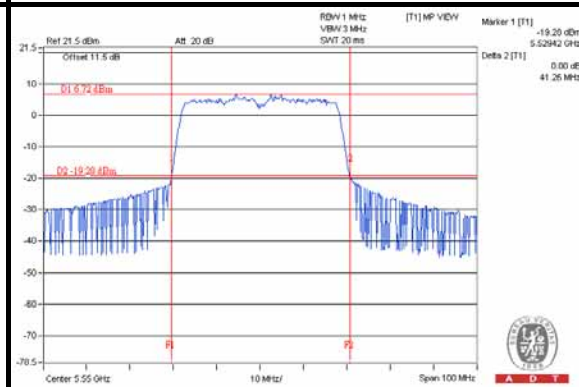

CH134

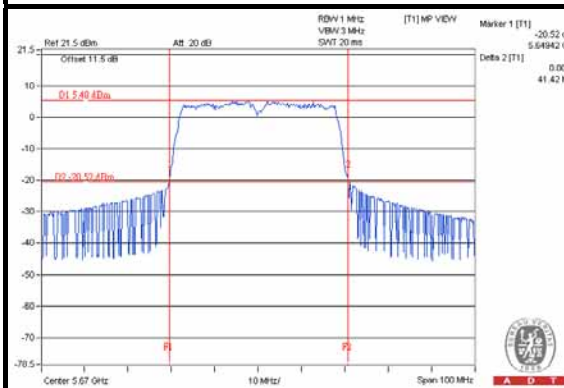

CH142 (UNII-2c Band) / CH142 (UNII-3 Band)

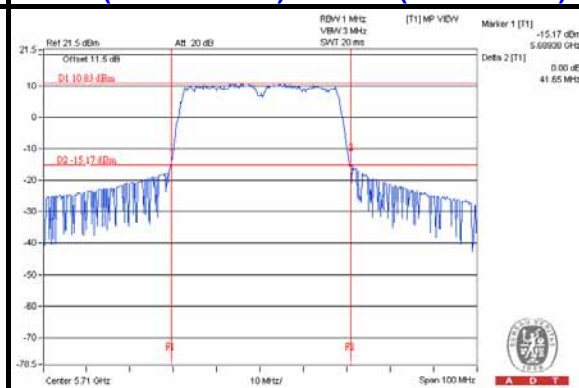

NOTE:

For CH142 (UNII-2c Band) = 5725 - Market 1

For CH142 (UNII-3 Band) = Delta 2 - CH142 (UNII-2c Band) BW



A D T

For Chain (2)

CH54

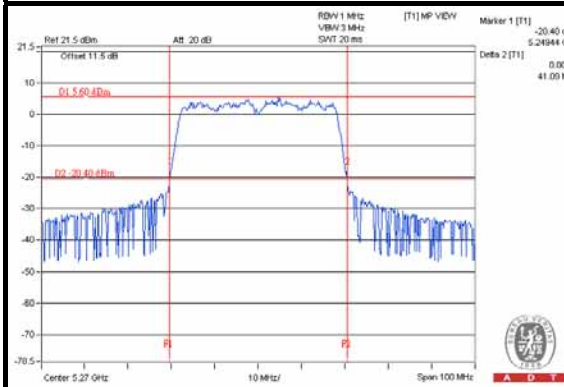

CH62

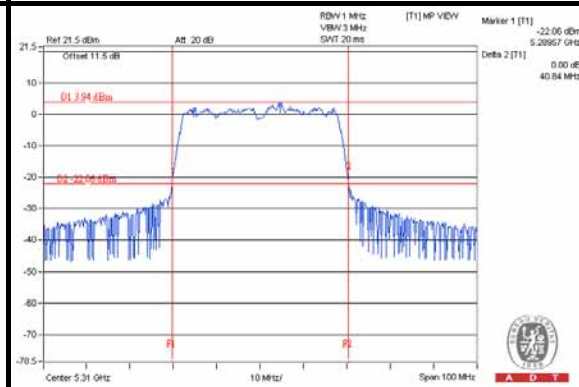

CH102

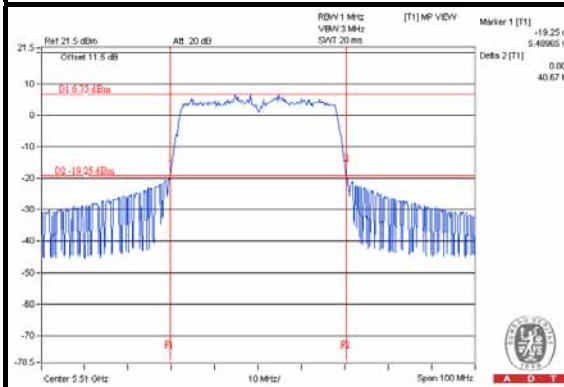

CH110

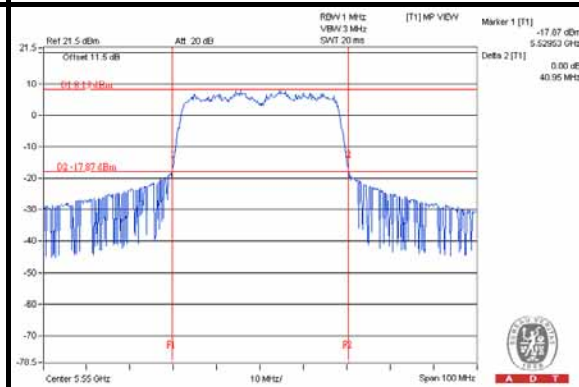

CH134

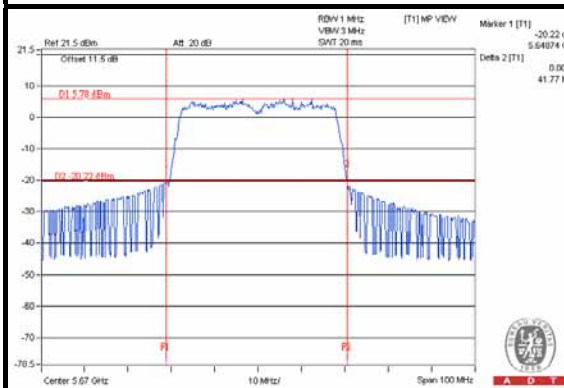

CH142 (UNII-2c Band) / CH142 (UNII-3 Band)

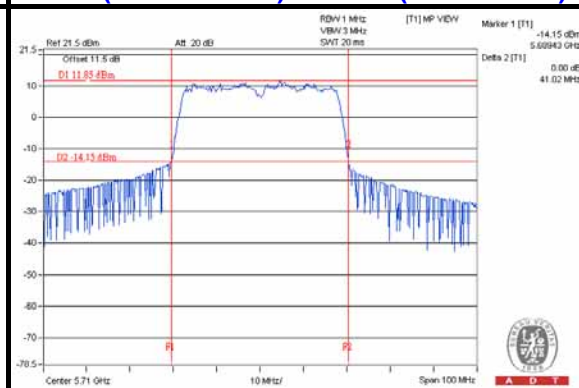

NOTE:

For CH142 (UNII-2c Band) = 5725 - Market 1

For CH142 (UNII-3 Band) = Delta 2 - CH142 (UNII-2c Band) BW



A D T

802.11ac (VHT80)

For Chain (0)

CH58

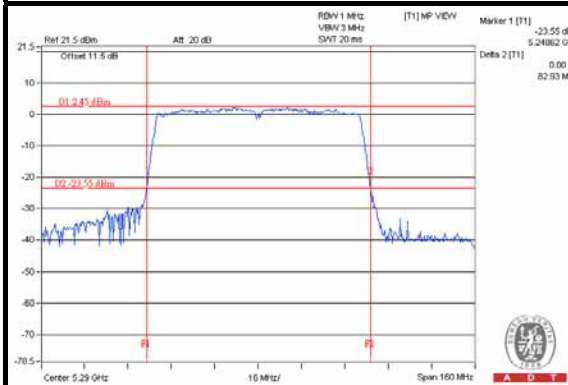

CH106

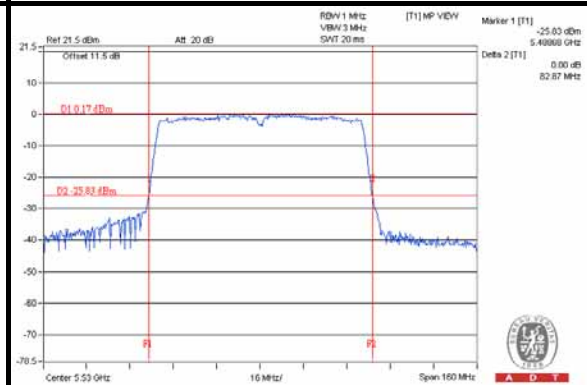

CH138 (UNII-2c Band) / CH138 (UNII-3 Band)

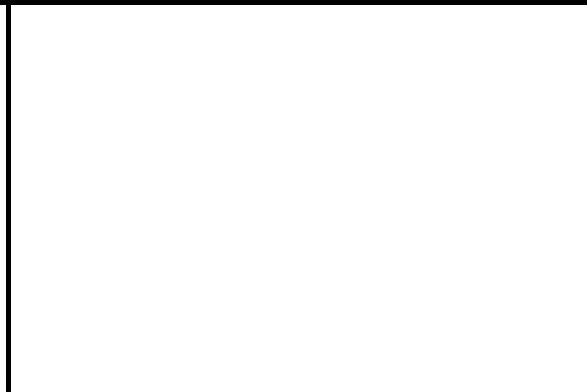
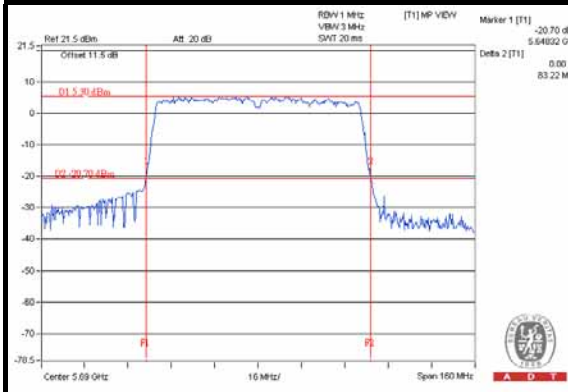

NOTE:

For CH138 (UNII-2c Band) = 5725 - Market 1

For CH138 (UNII-3 Band) = Delta 2 – CH138 (UNII-2c Band) BW



A D T

For Chain (1)

CH58

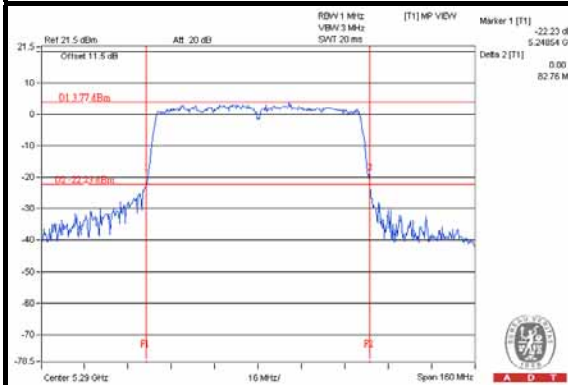

CH106

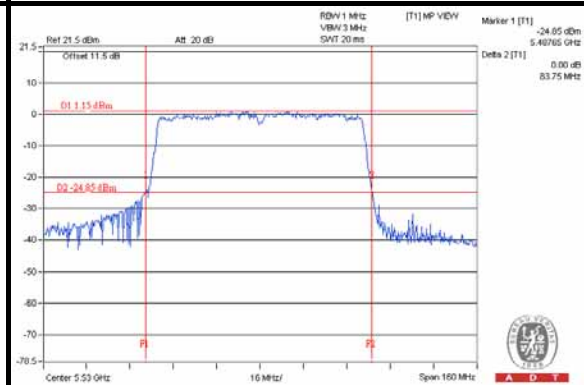

CH138 (UNII-2c Band) / CH138 (UNII-3 Band)

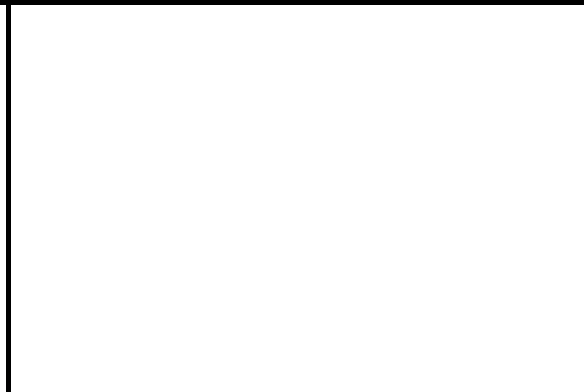
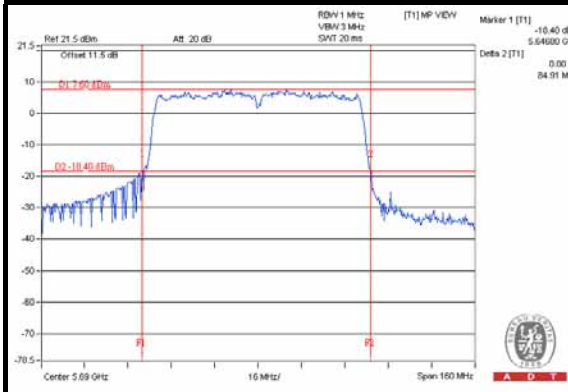

NOTE:

For CH138 (UNII-2c Band) = 5725 - Market 1

For CH138 (UNII-3 Band) = Delta 2 – CH138 (UNII-2c Band) BW



A D T

For Chain (2)

CH58

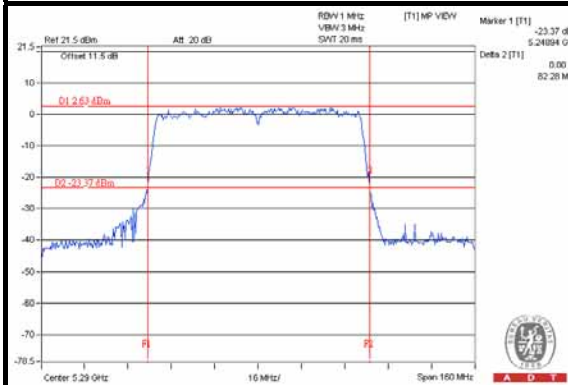

CH106

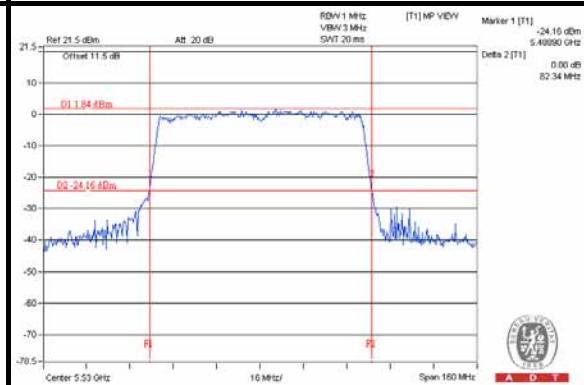

CH138 (UNII-2c Band) / CH138 (UNII-3 Band)

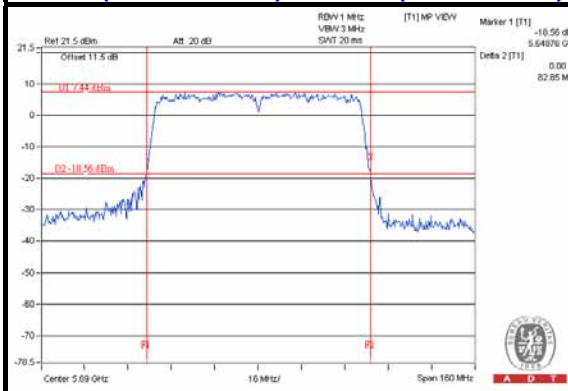

NOTE:

For CH138 (UNII-2c Band) = 5725 - Market 1

For CH138 (UNII-3 Band) = Delta 2 – CH138 (UNII-2c Band) BW



A D T

POWER OUTPUT:

STBC_MODE								
CHANNEL	FREQUENCY (MHz)	AVERAGE POWER (dBm)			TOTAL POWER (mW)	TOTAL POWER (dBm)	POWER LIMIT (dBm)	PASS / FAIL
		CHAIN 0	CHAIN 1	CHAIN 2				
802.11ac (VHT20)								
52	5260	6.32	8.13	4.41	13.547	11.32	24	PASS
60	5300	5.99	8.17	3.89	12.982	11.13	24	PASS
64	5320	5.98	7.87	3.69	12.426	10.94	24	PASS
100	5500	9.07	9.04	8.32	22.881	13.59	24	PASS
116	5580	11.60	12.10	11.49	44.765	16.51	24	PASS
132	5660	9.96	10.40	9.39	29.563	14.71	24	PASS
140	5700	9.61	11.01	10.51	33.005	15.19	24	PASS
144 (UNII-2c Band)	5720	11.17	13.03	12.56	51.213	17.09	22.80	PASS
144 (UNII-3 Band)	5720	5.38	7.15	6.83	13.458	11.29	24.15	PASS
802.11ac (VHT40)								
54	5270	10.26	11.39	9.14	32.593	15.13	24	PASS
62	5310	9.01	10.12	8.79	25.810	14.12	24	PASS
102	5510	11.71	12.31	11.64	46.435	16.67	24	PASS
110	5550	13.31	12.61	12.32	56.729	17.54	24	PASS
134	5670	12.14	12.93	12.59	54.157	17.34	24	PASS
142 (UNII-2c Band)	5710	13.33	14.97	14.65	82.107	19.14	24	PASS
142 (UNII-3 Band)	5710	2.88	4.52	4.45	7.558	8.78	24.33	PASS
802.11ac (VHT80)								
58	5290	11.01	12.17	10.12	39.38	15.95	24	PASS
106	5530	8.89	10.39	9.25	27.099	14.33	24	PASS
138 (UNII-2c Band)	5690	13.43	14.68	14.60	83.069	19.19	24	PASS
138 (UNII-3 Band)	5690	-0.91	0.63	0.76	3.2692	5.14	24.79	PASS



26dB OCCUPIED BANDWIDTH:

CHANNEL	CHANNEL FREQUENCY (MHz)	26dBc BANDWIDTH (MHz)		
		CHAIN 0	CHAIN 1	CHAIN 2
802.11ac (VHT20)				
52	5260	20.65	20.52	20.52
60	5300	20.66	20.38	20.55
64	5320	20.74	20.48	20.59
100	5500	20.64	20.60	20.68
116	5580	20.79	20.54	20.52
132	5660	20.94	20.45	20.68
140	5700	20.64	20.48	20.74
144 (UNII-2c Band)	5720	15.36	15.17	15.17
144 (UNII-3 Band)	5720	5.34	5.23	5.19
802.11ac (VHT40)				
54	5270	41.60	40.91	41.09
62	5310	41.63	41.26	40.84
102	5510	41.20	41.33	41.23
110	5550	41.18	41.16	41.45
134	5670	41.31	41.18	41.56
142 (UNII-2c Band)	5710	35.82	35.63	35.56
142 (UNII-3 Band)	5710	5.65	6.07	5.42
802.11ac (VHT80)				
58	5290	82.93	82.76	82.28
106	5530	82.87	83.75	82.34
138 (UNII-2c Band)	5690	76.78	77.57	76.14
138 (UNII-3 Band)	5690	6.49	6.39	6.02

Note: For output power limitation is determined based on 26dBc bandwidth.



A D T

Power Limit = 11dBm + 10logB < UNII Band 2~3>			
Channel Number	Freq.(MHz)	Min. B(MHz)	Determined Conducted Limit (dBm)
802.11ac (VHT20)			
52	5260	20.52	24.12 > 24
60	5300	20.38	24.09 > 24
64	5320	20.48	24.11 > 24
100	5500	20.60	24.13 > 24
116	5580	20.52	24.12 > 24
132	5660	20.45	24.1 > 24
140	5700	20.48	24.11 > 24
144 (UNII-2c Band)	5720	15.17	22.8 < 24
144 (UNII-3 Band)	5720	5.19	24.15 < 30
802.11ac (VHT40)			
54	5270	40.91	27.11 > 24
62	5310	40.84	27.11 > 24
102	5510	41.20	27.14 > 24
110	5550	41.16	27.14 > 24
134	5670	41.18	27.14 > 24
142 (UNII-2c Band)	5710	35.56	26.5 > 24
142 (UNII-3 Band)	5710	5.42	24.33 < 30
802.11ac (VHT80)			
58	5290	82.28	30.15 > 24
106	5530	82.34	30.15 > 24
138 (UNII-2c Band)	5690	76.14	29.81 > 24
138 (UNII-3 Band)	5690	6.02	24.79 < 30



A D T

802.11ac (VHT20)

For Chain (0)

CH52

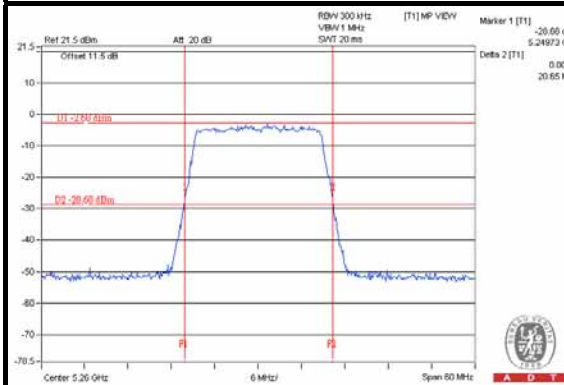

CH60

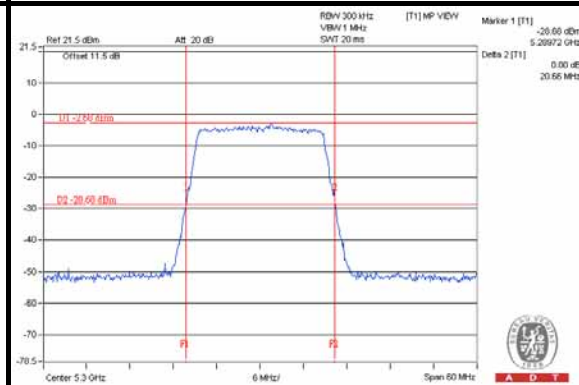

CH64

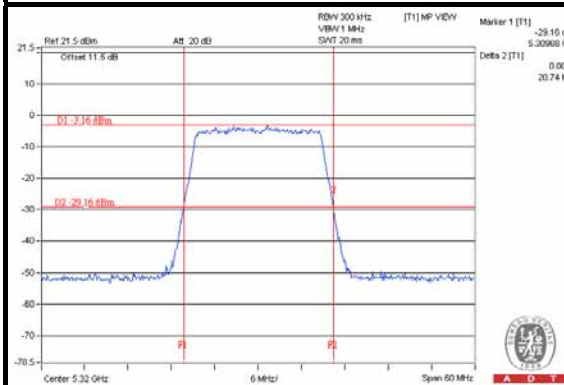

CH100

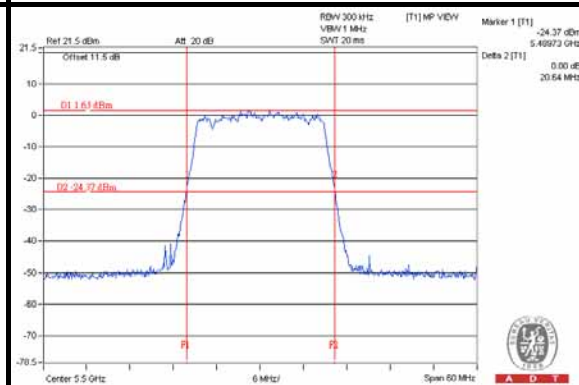

CH116

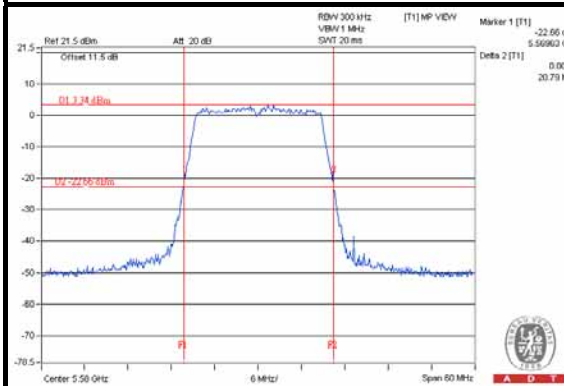

CH132

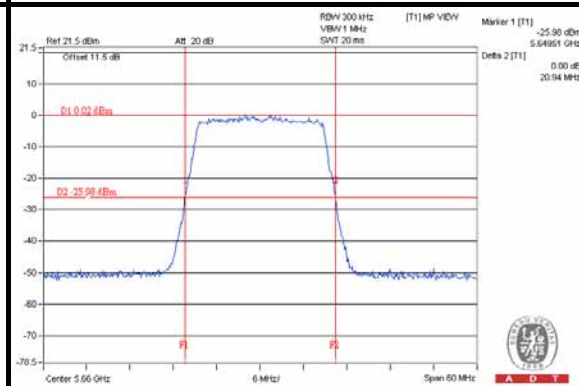



A D T

CH140

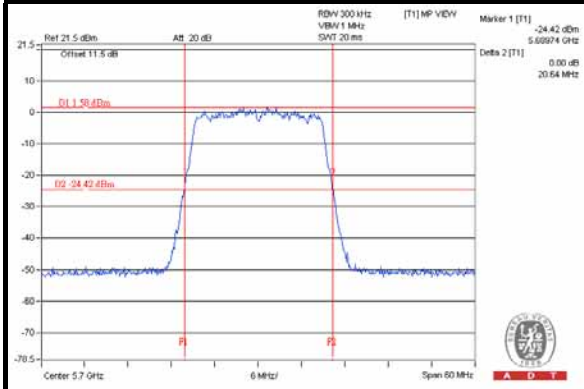

CH144 (UNII-2c Band) / CH144 (UNII-3 Band)

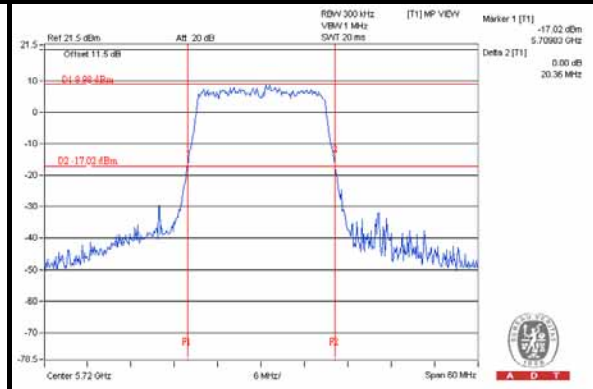

NOTE:

For CH144 (UNII-2c Band) = 5725 - Market 1

For CH144 (UNII-3 Band) = Delta 2 - CH144 (UNII-2c Band) BW



A D T

For Chain (1)

CH52

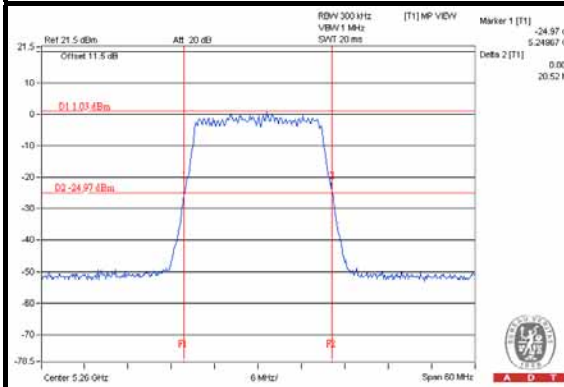

CH60

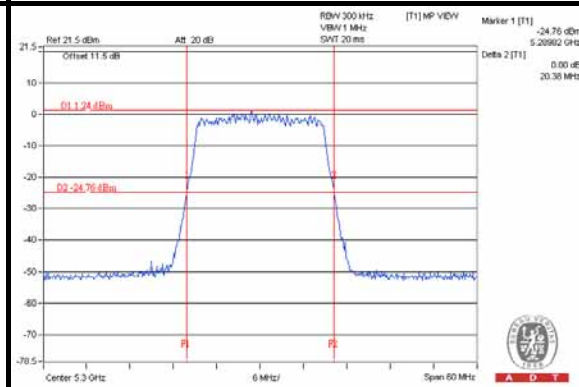

CH64

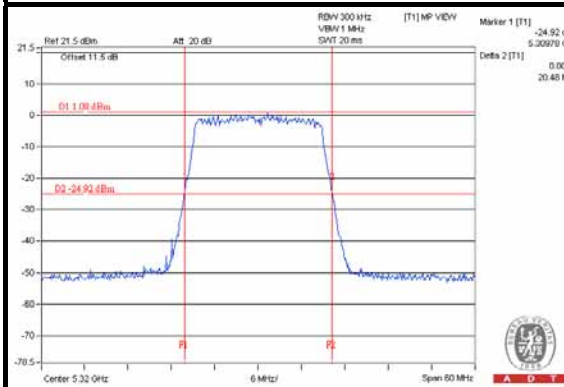

CH100

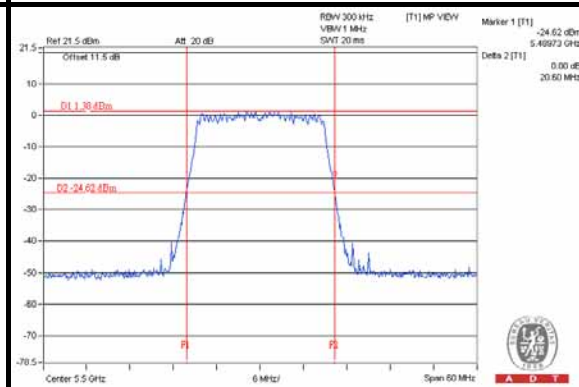

CH116

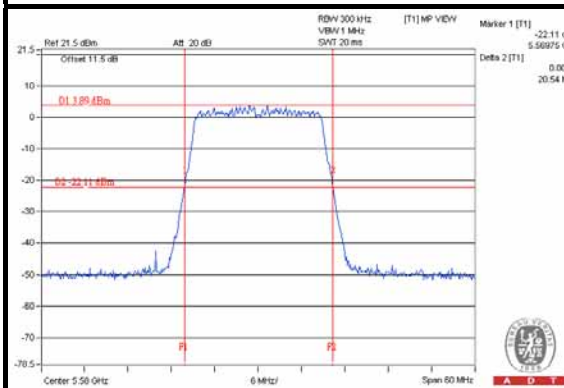

CH132

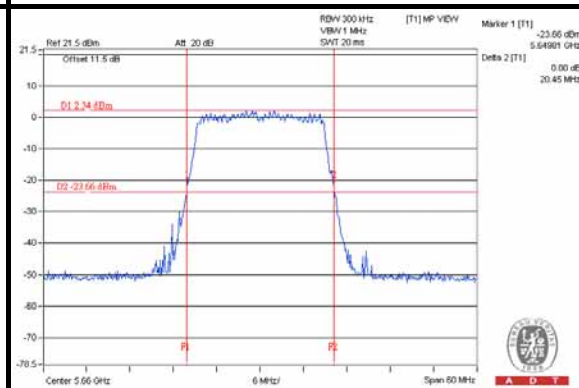



A D T

CH140

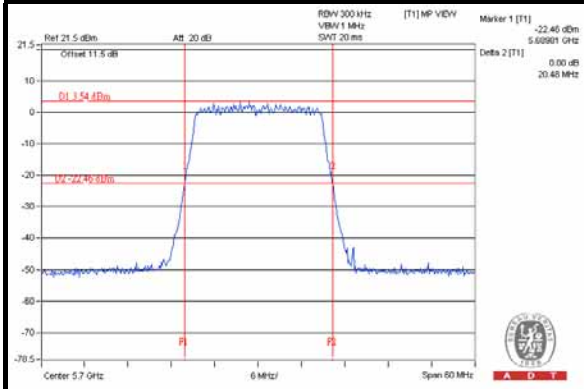

CH144 (UNII-2c Band) / CH144 (UNII-3 Band)

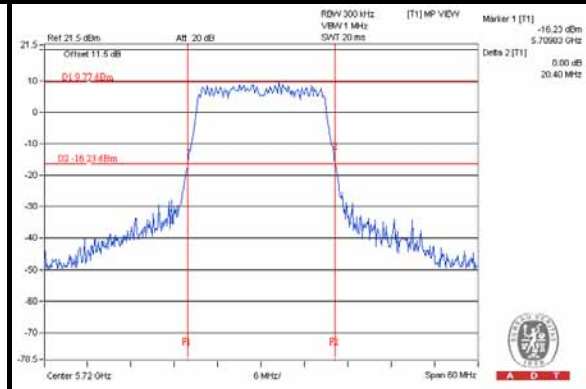

NOTE:

For CH144 (UNII-2c Band) = 5725 - Market 1

For CH144 (UNII-3 Band) = Delta 2 - CH144 (UNII-2c Band) BW



A D T

For Chain (2)

CH52

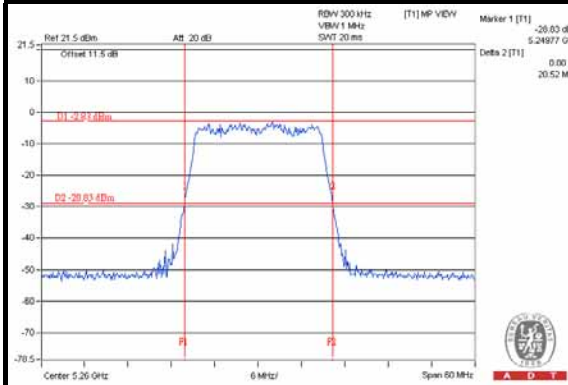

CH60

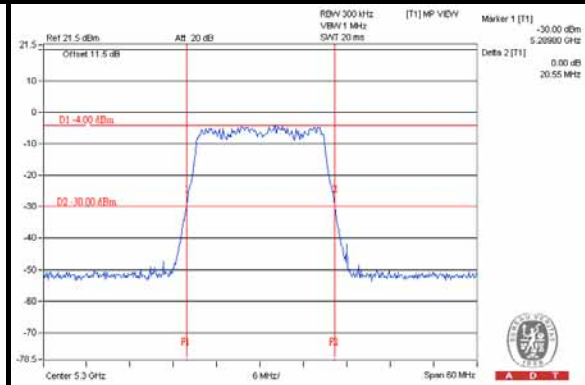

CH64

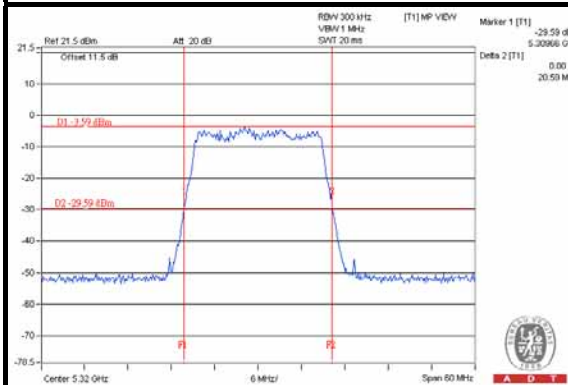

CH100

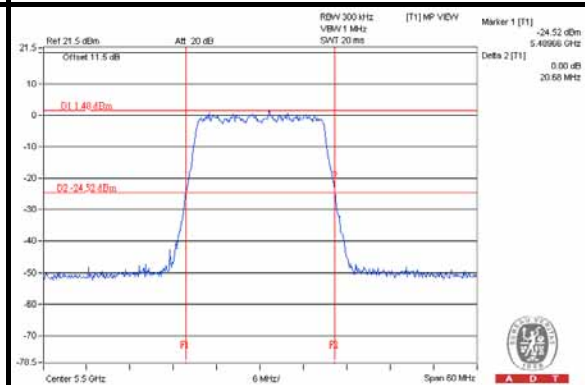

CH116

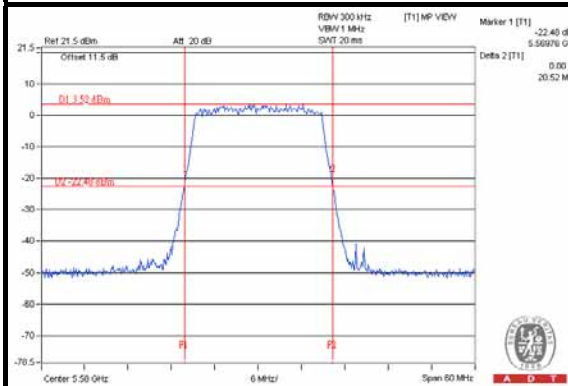

CH132

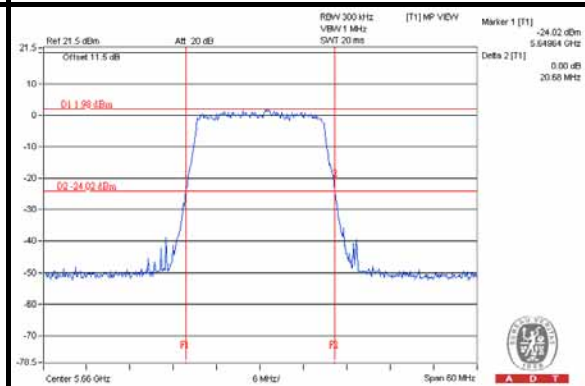



A D T

CH140

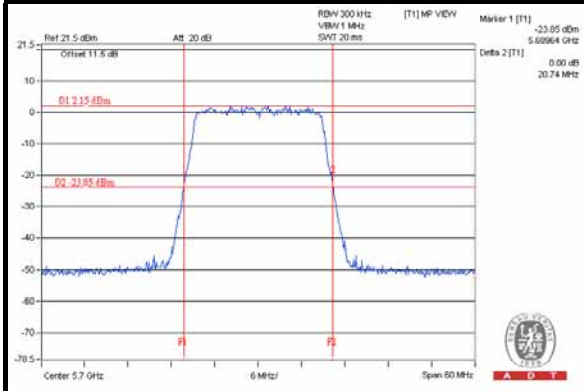

CH144 (UNII-2c Band) / CH144 (UNII-3 Band)

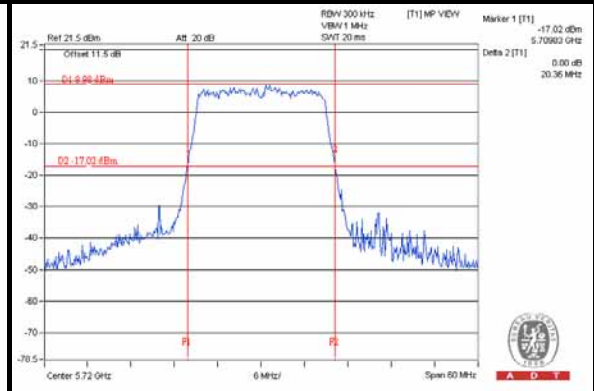

NOTE:

For CH144 (UNII-2c Band) = 5725 - Market 1

For CH144 (UNII-3 Band) = Delta 2 - CH144 (UNII-2c Band) BW



A D T

802.11ac (VHT40)

For Chain (0)

CH54

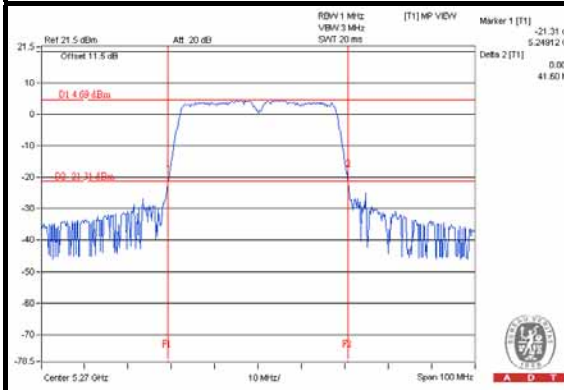

CH62

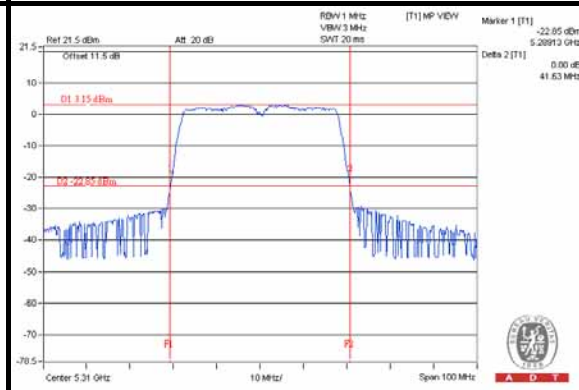

CH102

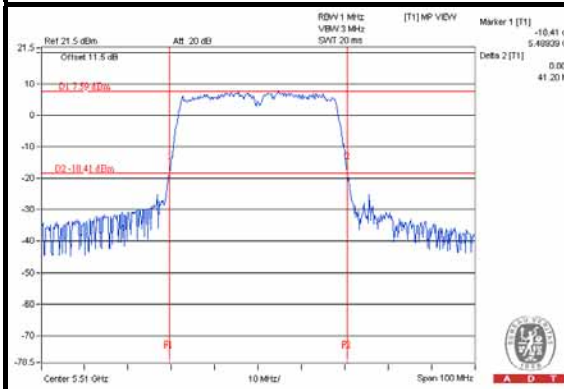

CH110

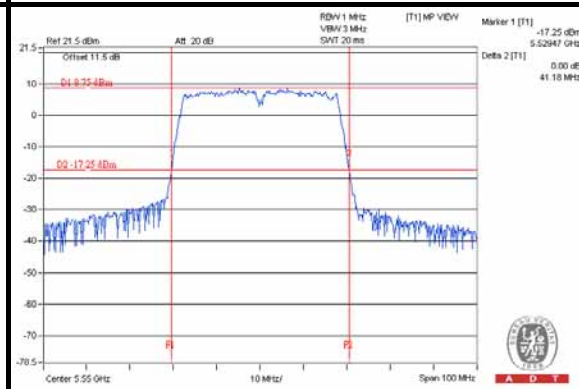

CH134

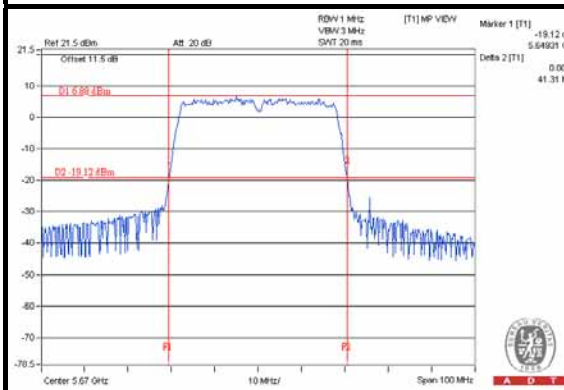

CH142 (UNII-2c Band) / CH142 (UNII-3 Band)

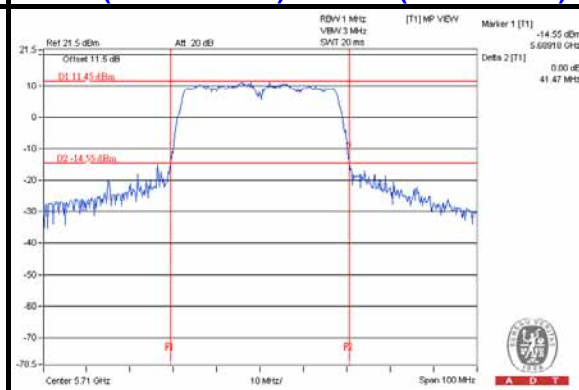

NOTE:

For CH142 (UNII-2c Band) = 5725 - Market 1

For CH142 (UNII-3 Band) = Delta 2 - CH142 (UNII-2c Band) BW



A D T

For Chain (1)

CH54

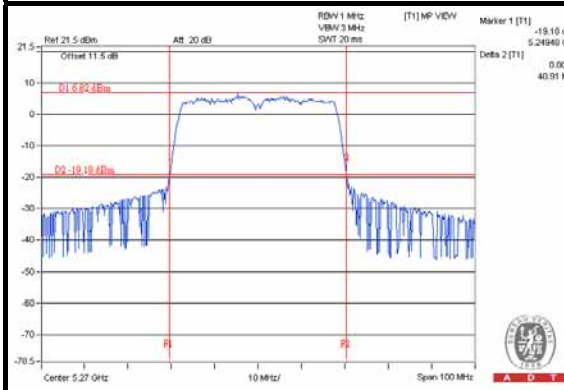

CH62

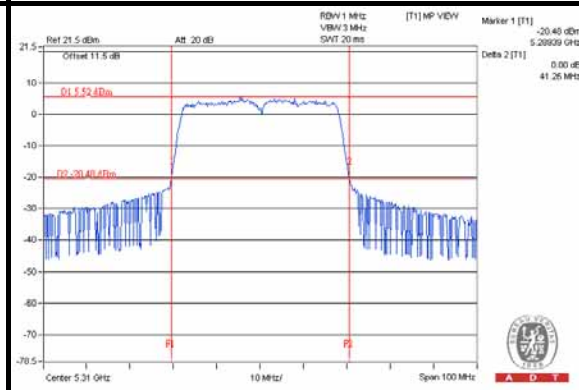

CH102

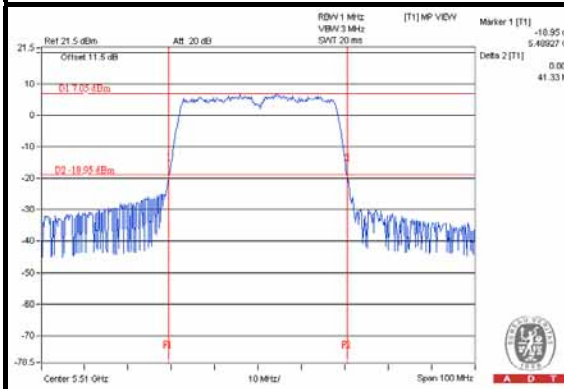

CH110

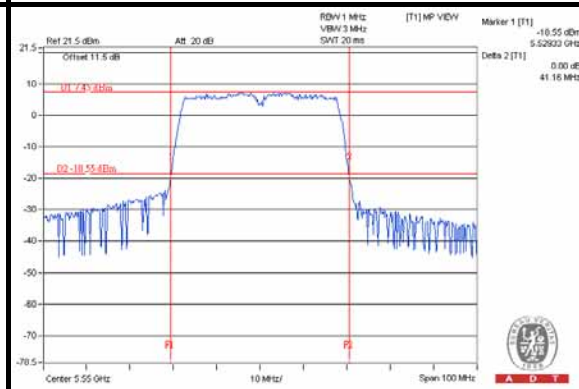

CH134

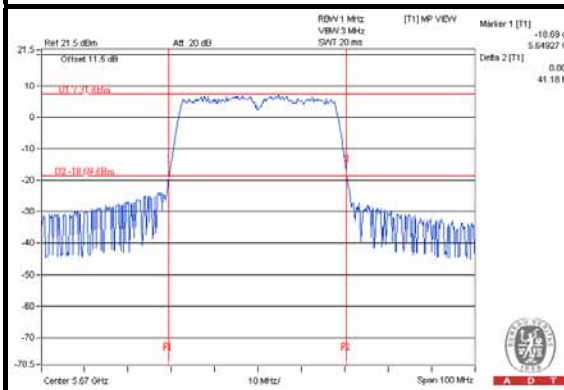

CH142 (UNII-2c Band) / CH142 (UNII-3 Band)

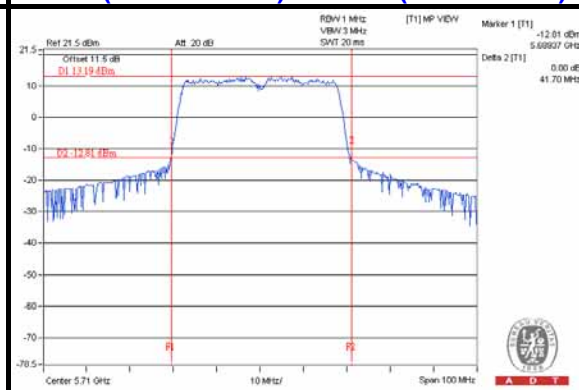

NOTE:

For CH142 (UNII-2c Band) = 5725 - Market 1

For CH142 (UNII-3 Band) = Delta 2 - CH142 (UNII-2c Band) BW



A D T

For Chain (2)

CH54

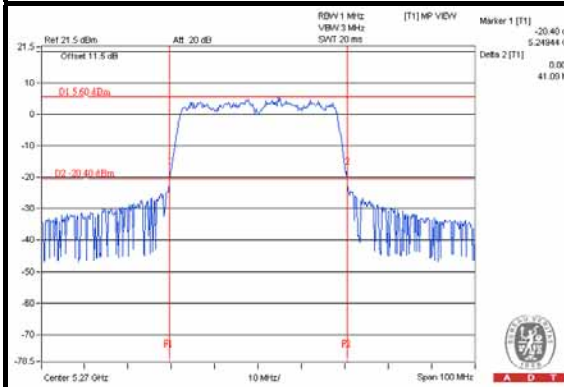

CH62

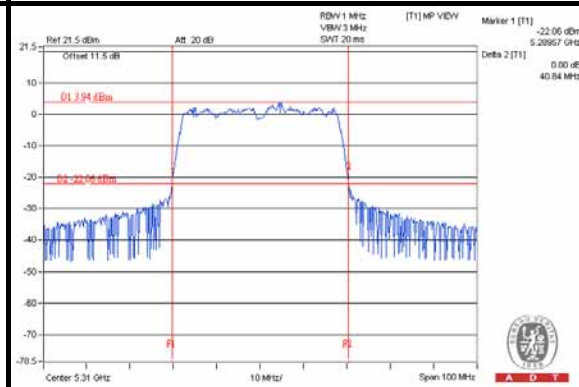

CH102

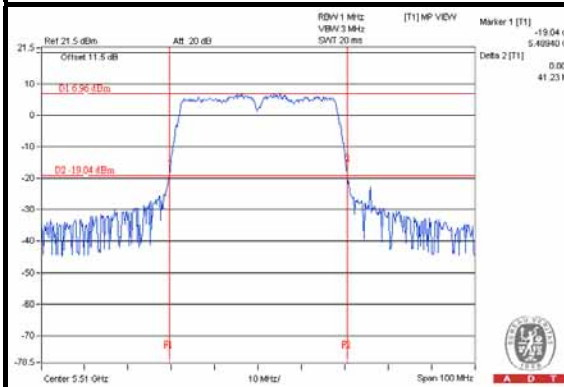

CH110

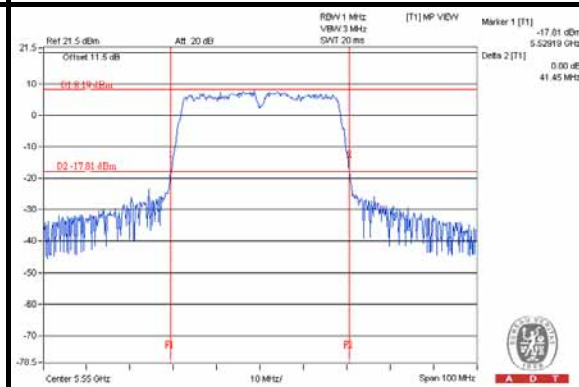

CH134

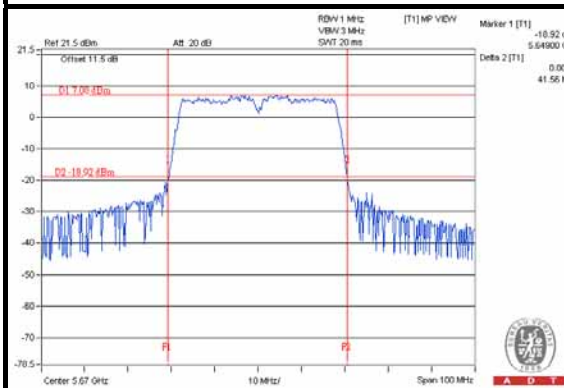

CH142 (UNII-2c Band) / CH142 (UNII-3 Band)

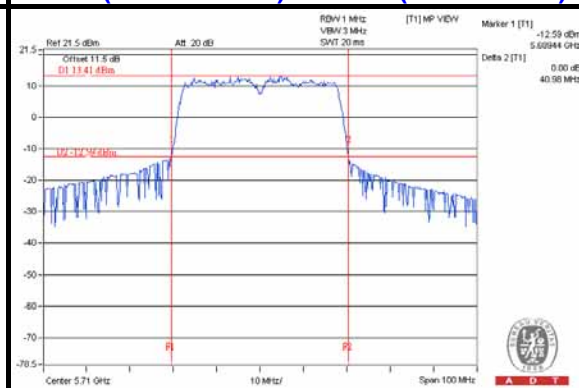

NOTE:

For CH142 (UNII-2c Band) = 5725 - Market 1

For CH142 (UNII-3 Band) = Delta 2 - CH142 (UNII-2c Band) BW



A D T

802.11ac (VHT80)

For Chain (0)

CH58

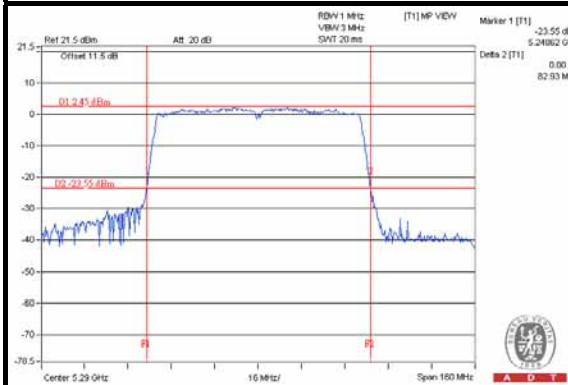

CH106

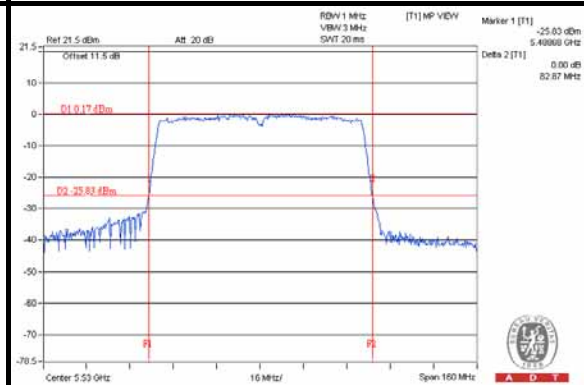

CH138 (UNII-2c Band) / CH138 (UNII-3 Band)

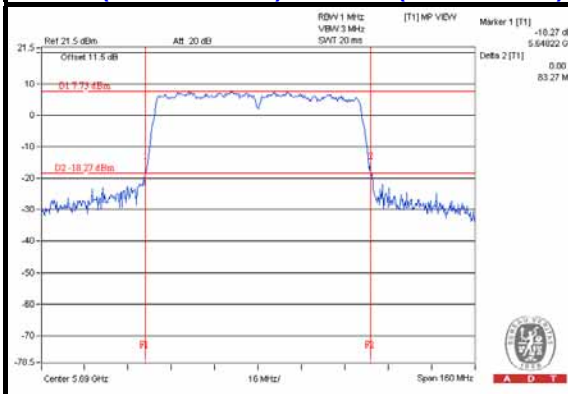

NOTE:

For CH138 (UNII-2c Band) = 5725 - Market 1

For CH138 (UNII-3 Band) = Delta 2 – CH138 (UNII-2c Band) BW



A D T

For Chain (1)

CH58

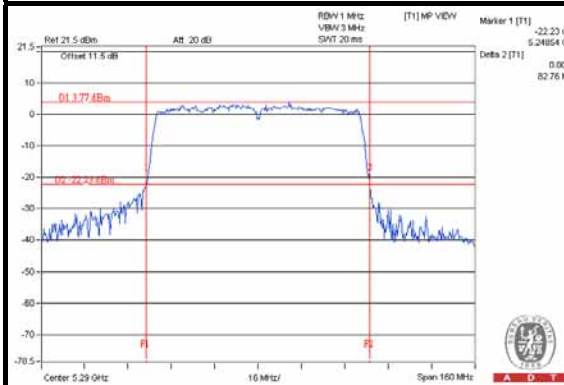

CH106

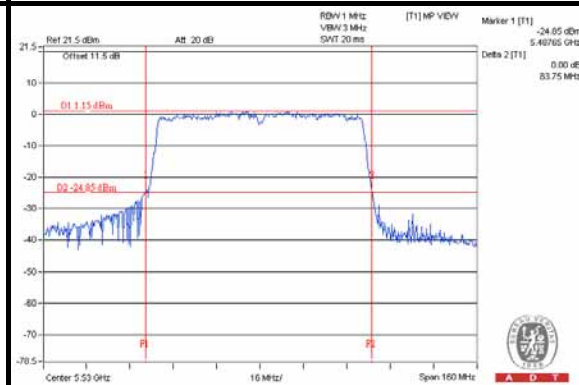

CH138 (UNII-2c Band) / CH138 (UNII-3 Band)

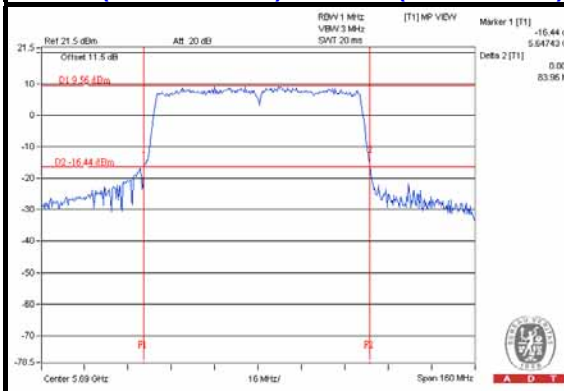

NOTE:

For CH138 (UNII-2c Band) = 5725 - Market 1

For CH138 (UNII-3 Band) = Delta 2 – CH138 (UNII-2c Band) BW



A D T

For Chain (2)

CH58

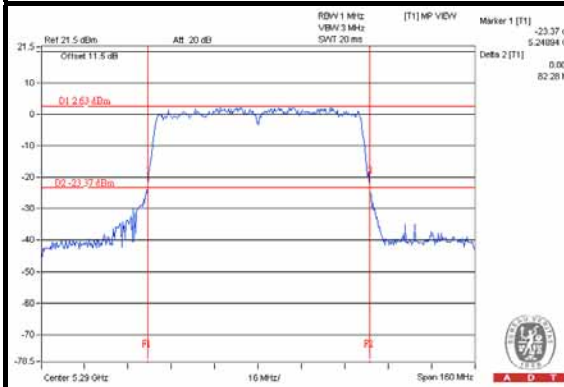

CH106

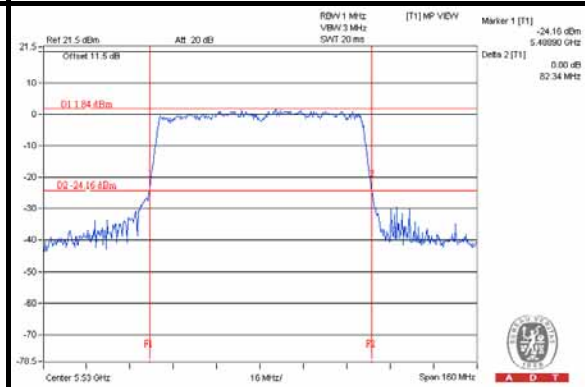

CH138 (UNII-2c Band) / CH138 (UNII-3 Band)

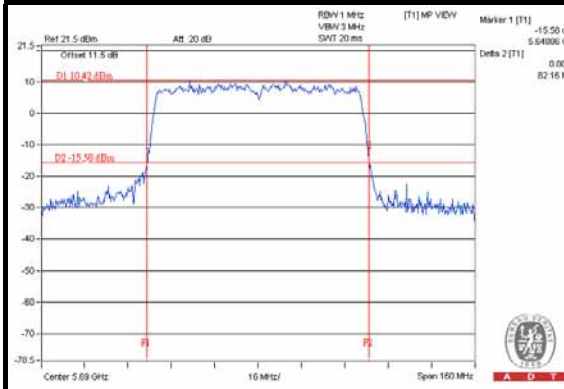

NOTE:

For CH138 (UNII-2c Band) = 5725 - Market 1

For CH138 (UNII-3 Band) = Delta 2 – CH138 (UNII-2c Band) BW



A D T

4.3.8 TEST RESULTS (MODE 2)

POWER OUTPUT:

CDD, SDM & Beamforming (MCS0 NSS=2)_MODE							
CHANNEL	FREQUENCY (MHz)	AVERAGE POWER (dBm)		TOTAL POWER (mW)	TOTAL POWER (dBm)	POWER LIMIT (dBm)	PASS / FAIL
		CHAIN 0	CHAIN 1				
802.11ac (VHT20)							
52	5260	8.56	10.02	17.224	12.36	24	PASS
60	5300	8.45	9.91	16.793	12.25	24	PASS
64	5320	8.61	10.14	17.589	12.45	24	PASS
100	5500	10.71	11.68	26.499	14.23	24	PASS
116	5580	14.41	14.51	55.855	17.47	24	PASS
132	5660	13.63	13.83	47.222	16.74	24	PASS
140	5700	13.35	13.55	44.273	16.46	24	PASS
144 (UNII-2c Band)	5720	12.36	14.34	44.383	16.47	22.83	PASS
144 (UNII-3 Band)	5720	6.47	8.48	11.483	10.60	24.22	PASS
802.11ac (VHT40)							
54	5270	12.35	13.07	37.456	15.74	24	PASS
62	5310	12.15	13.09	36.776	15.66	24	PASS
102	5510	11.46	12.28	30.900	14.90	24	PASS
110	5550	13.65	14.53	51.553	17.12	24	PASS
134	5670	14.92	14.98	62.523	17.96	24	PASS
142 (UNII-2c Band)	5710	14.99	16.90	80.528	19.06	24	PASS
142 (UNII-3 Band)	5710	4.43	6.48	7.219	8.58	24.42	PASS
802.11ac (VHT80)							
58	5290	13.39	14.13	47.709	16.79	24	PASS
106	5530	11.17	11.88	28.509	14.55	24	PASS
138 (UNII-2c Band)	5690	15.66	17.30	96.912	19.86	24	PASS
138 (UNII-3 Band)	5690	1.16	3.29	3.682	5.66	25.11	PASS
For CH138: Average Power (dBm)= measured value(dBm) + Duty Factor (0.3dB)							



26dB OCCUPIED BANDWIDTH:

CHANNEL	CHANNEL FREQUENCY (MHz)	26dBc BANDWIDTH (MHz)	
		CHAIN 0	CHAIN 1
802.11ac (VHT20)			
52	5260	20.81	20.61
60	5300	20.77	20.57
64	5320	20.78	20.55
100	5500	20.68	20.44
116	5580	20.85	20.56
132	5660	20.86	20.62
140	5700	20.75	20.57
144 (UNII-2c Band)	5720	15.26	15.32
144 (UNII-3 Band)	5720	5.29	5.28
802.11ac (VHT40)			
54	5270	41.01	40.62
62	5310	41.17	40.69
102	5510	41.25	40.71
110	5550	40.86	40.71
134	5670	41.12	40.82
142 (UNII-2c Band)	5710	38.88	36.05
142 (UNII-3 Band)	5710	11.01	5.54
802.11ac (VHT80)			
58	5290	83.30	82.68
106	5530	83.00	82.55
138 (UNII-2c Band)	5690	76.90	76.56
138 (UNII-3 Band)	5690	10.48	6.48

Note: For output power limitation is determined based on 26dBc bandwidth.



A D T

Power Limit = 11dBm + 10logB < UNII Band 2~3>			
Channel Number	Freq.(MHz)	Min. B(MHz)	Determined Conducted Limit (dBm)
802.11ac (VHT20)			
52	5260	20.61	24.14 > 24
60	5300	20.57	24.13 > 24
64	5320	20.55	24.12 > 24
100	5500	20.44	24.1 > 24
116	5580	20.56	24.13 > 24
132	5660	20.62	24.14 > 24
140	5700	20.57	24.13 > 24
144 (UNII-2c Band)	5720	15.26	22.83 < 24
144 (UNII-3 Band)	5720	5.28	24.22 < 30
802.11ac (VHT40)			
54	5270	40.62	27.08 > 24
62	5310	40.69	27.09 > 24
102	5510	40.71	27.09 > 24
110	5550	40.71	27.09 > 24
134	5670	40.82	27.1 > 24
142 (UNII-2c Band)	5710	36.05	26.56 > 24
142 (UNII-3 Band)	5710	5.53	24.42 < 30
802.11ac (VHT80)			
58	5290	82.68	30.17 > 24
106	5530	82.55	30.16 > 24
138 (UNII-2c Band)	5690	76.56	29.84 > 24
138 (UNII-3 Band)	5690	6.48	25.11 < 30



A D T

802.11ac (VHT20)

For Chain (0)

CH52

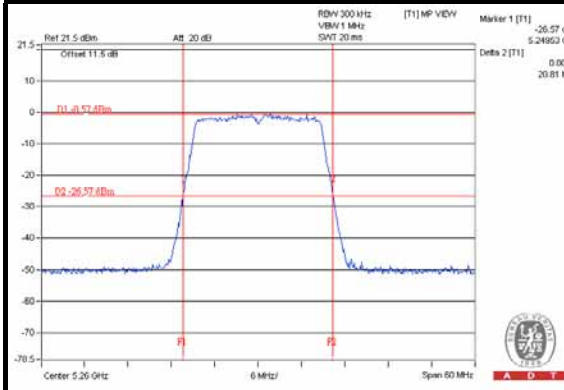

CH60

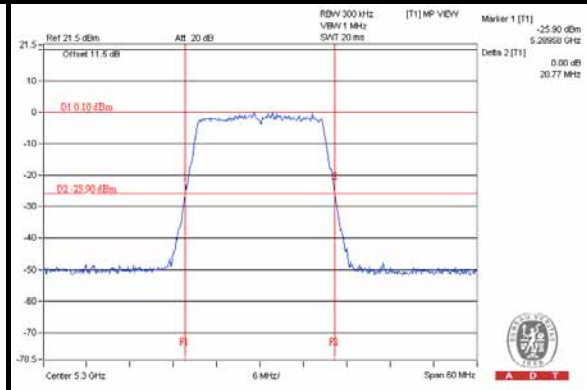

CH64

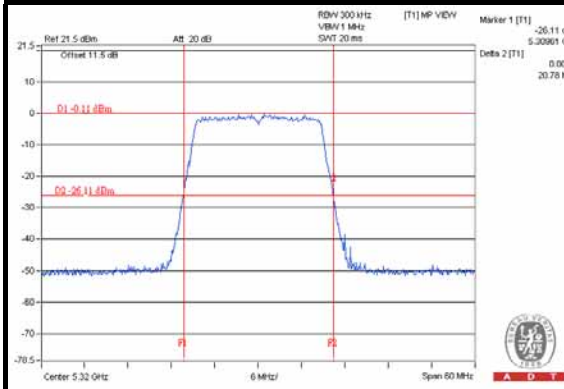

CH100

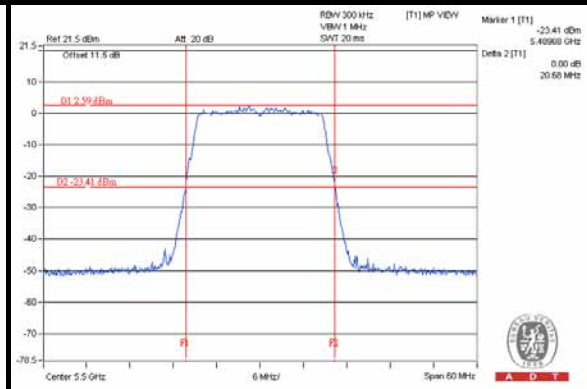

CH116

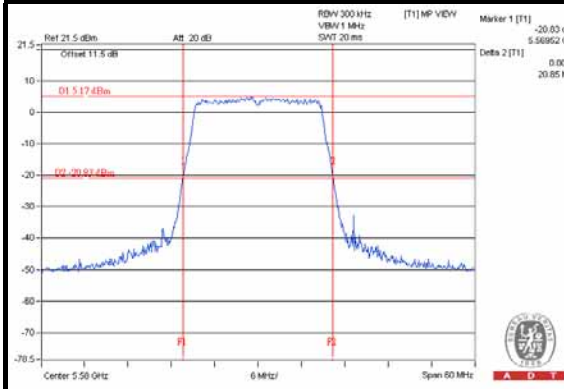

CH132

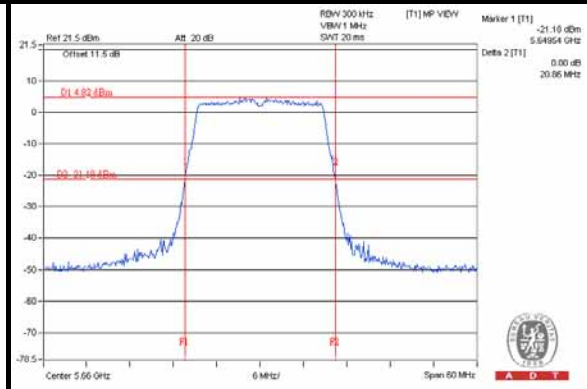



A D T

CH140

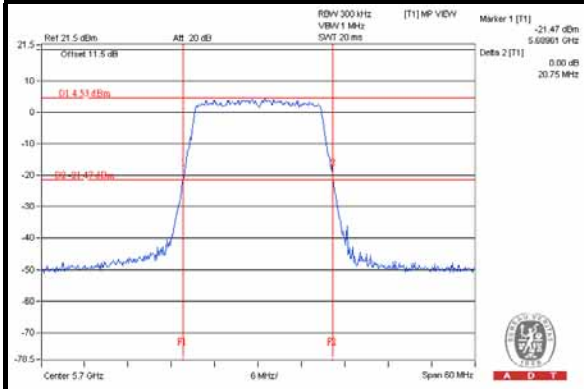

CH144 (UNII-2c Band) / CH144 (UNII-3 Band)

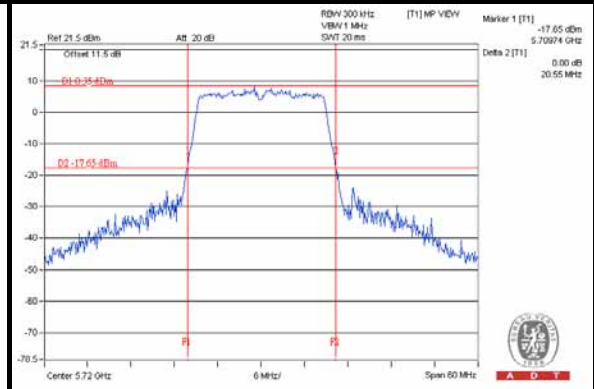

NOTE:

For CH144 (UNII-2c Band) = 5725 - Market 1

For CH144 (UNII-3 Band) = Delta 2 - CH144 (UNII-2c Band) BW

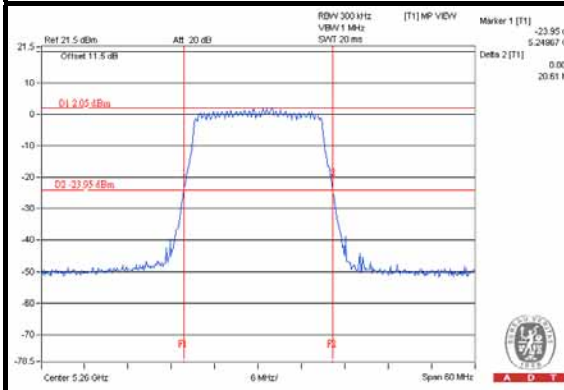
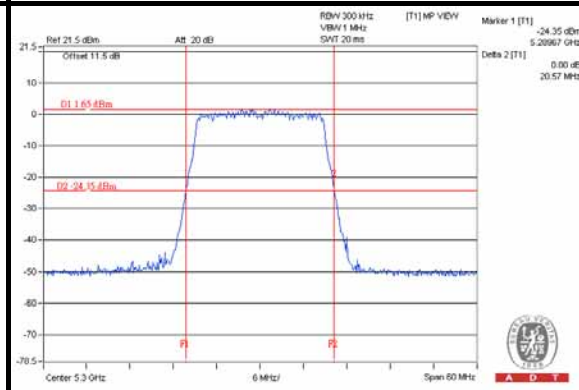
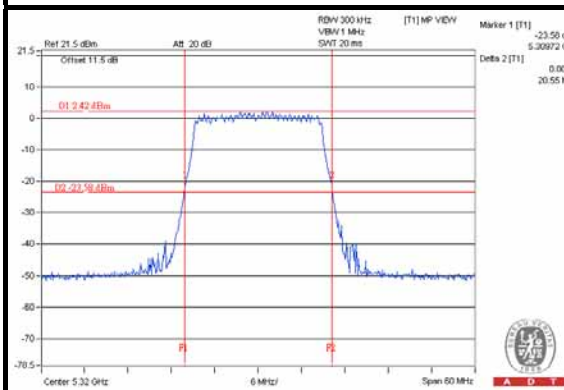
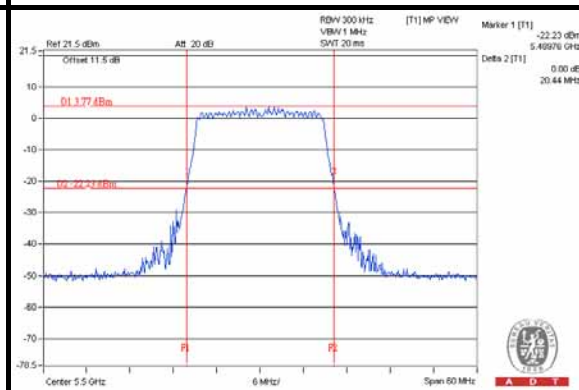
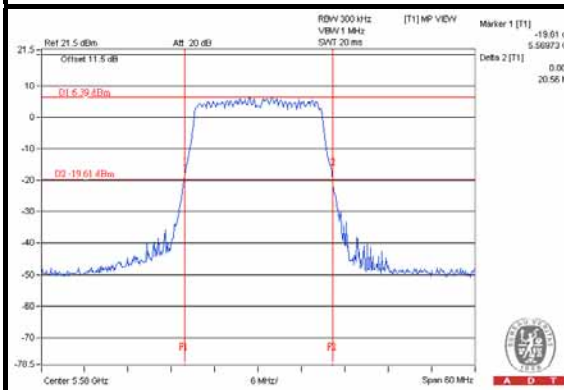
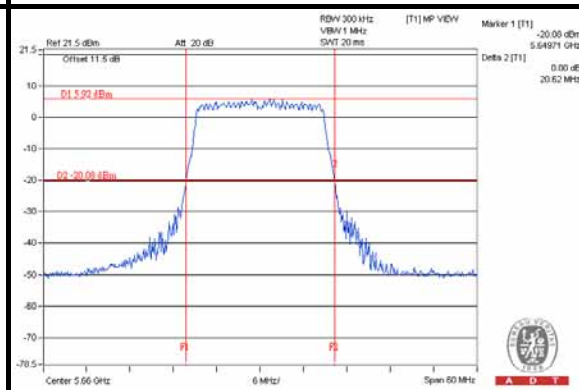
For Chain (1)**CH52****CH60****CH64****CH100****CH116****CH132**



A D T

CH140

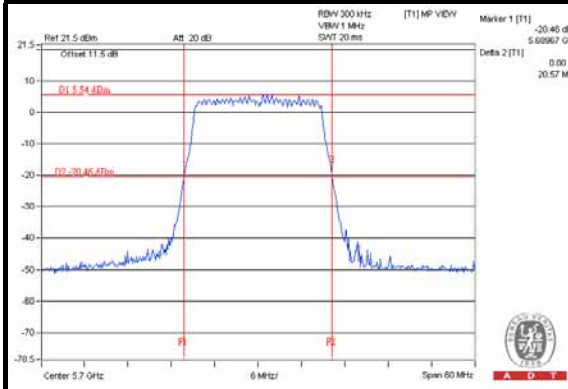

CH144 (UNII-2c Band) / CH144 (UNII-3 Band)

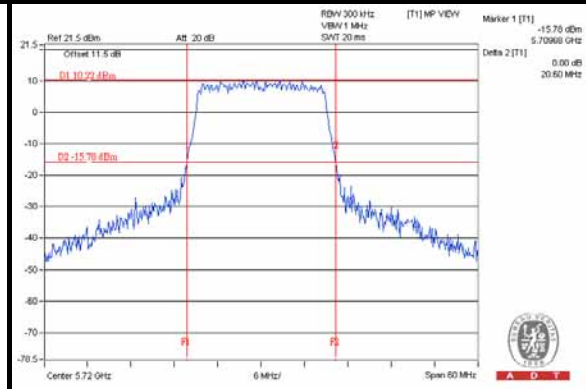

NOTE:

For CH144 (UNII-2c Band) = 5725 - Market 1

For CH144 (UNII-3 Band) = Delta 2 - CH144 (UNII-2c Band) BW



A D T

802.11ac (VHT40)

For Chain (0)

CH54

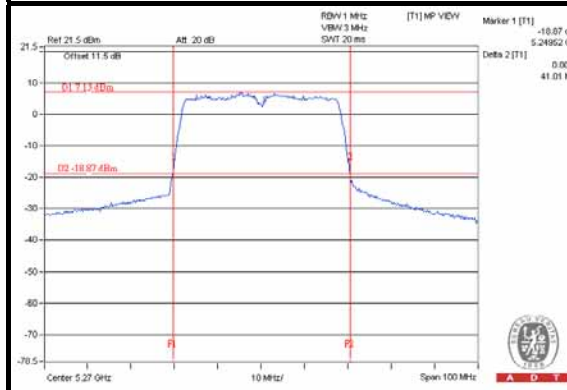

CH62

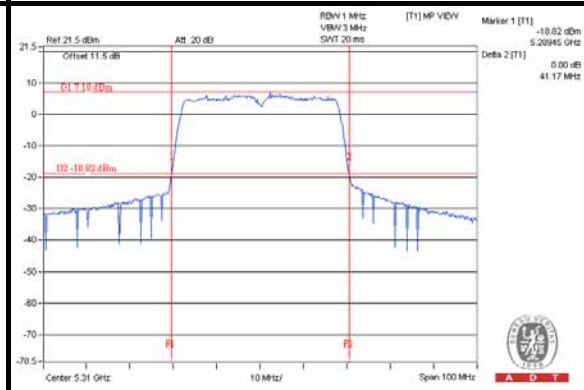

CH102

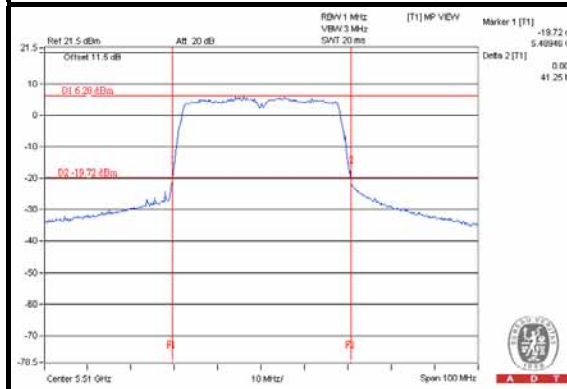

CH110

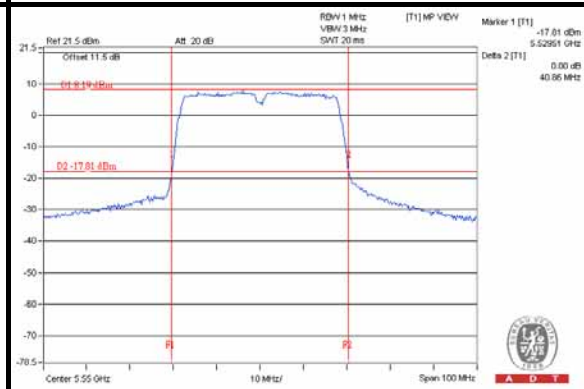

CH134

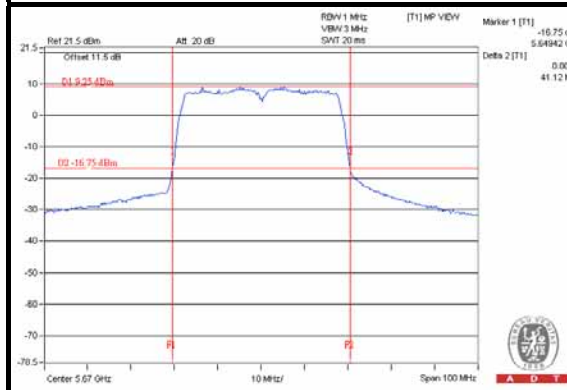

CH142 (UNII-2c Band) / CH142 (UNII-3 Band)

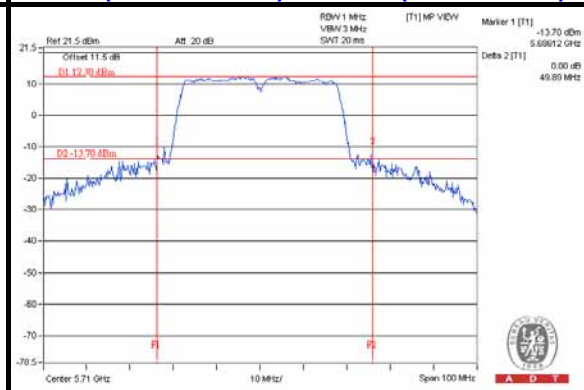

NOTE:

For CH142 (UNII-2c Band) = 5725 - Market 1

For CH142 (UNII-3 Band) = Delta 2 - CH142 (UNII-2c Band) BW



A D T

For Chain (1)

CH54

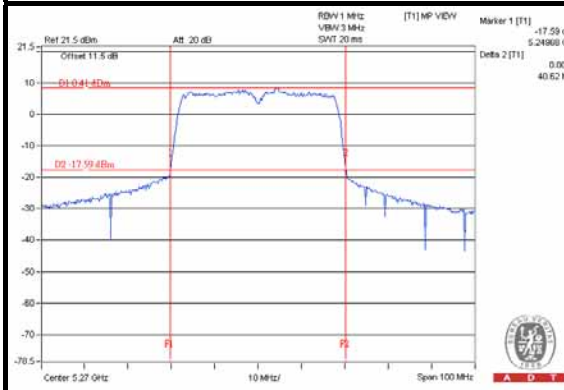

CH62

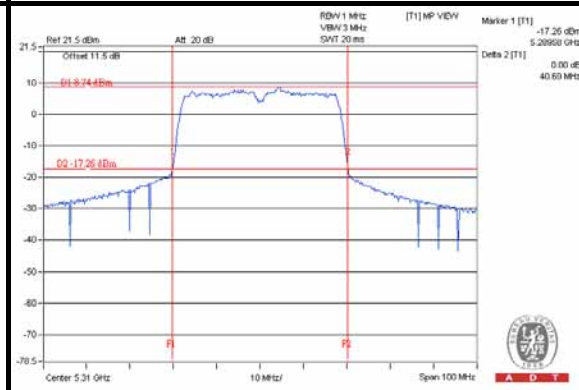

CH102

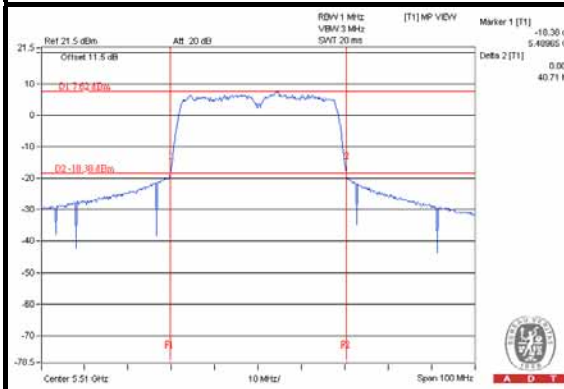

CH110

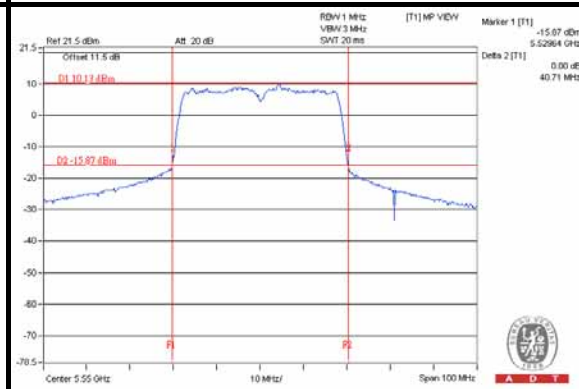

CH134

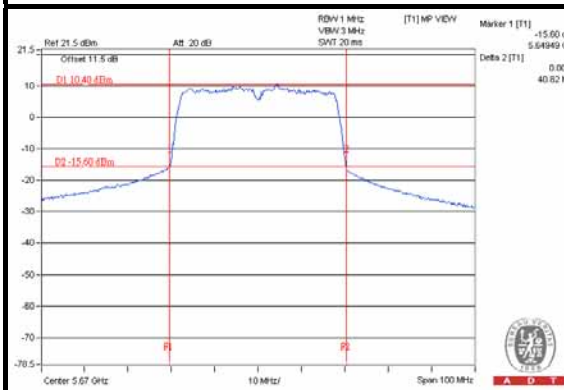

CH142 (UNII-2c Band) / CH142 (UNII-3 Band)

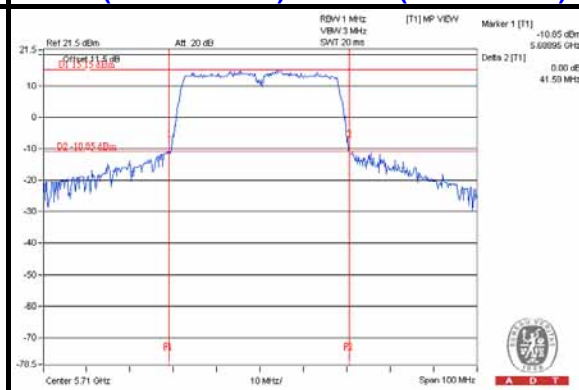

NOTE:

For CH142 (UNII-2c Band) = 5725 - Market 1

For CH142 (UNII-3 Band) = Delta 2 - CH142 (UNII-2c Band) BW



A D T

802.11ac (VHT80)

For Chain (0)

CH58

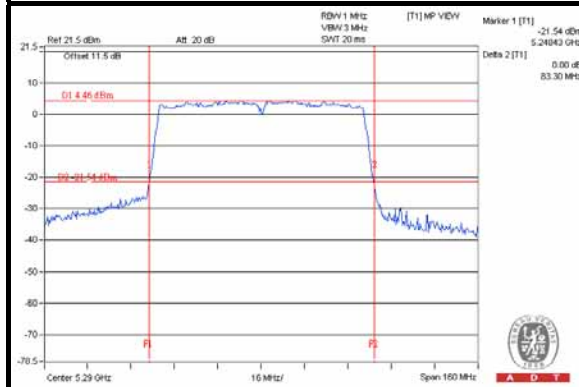

CH106

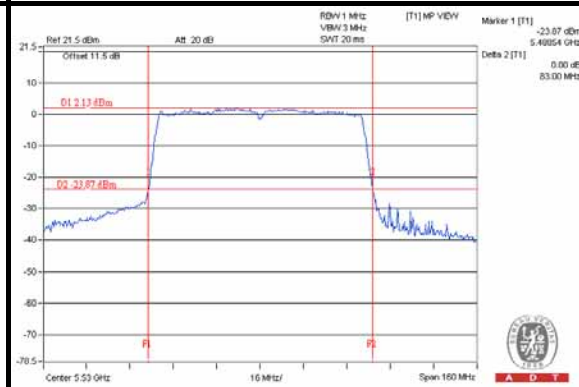

CH138 (UNII-2c Band) / CH138 (UNII-3 Band)

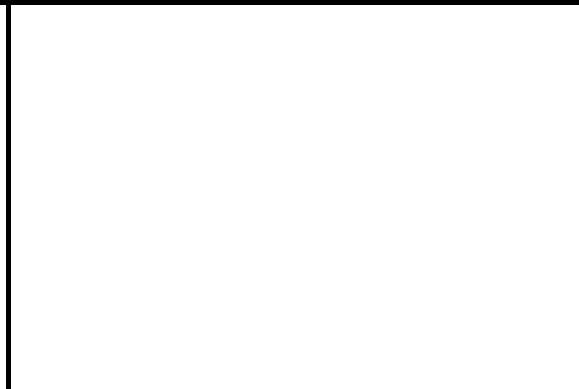
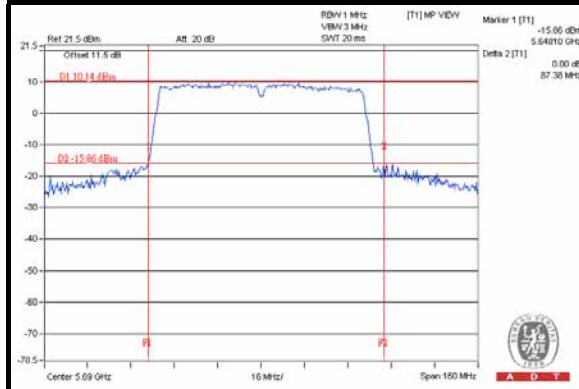

NOTE:

For CH138 (UNII-2c Band) = 5725 - Market 1

For CH138 (UNII-3 Band) = Delta 2 – CH138 (UNII-2c Band) BW



A D T

For Chain (1)

CH58

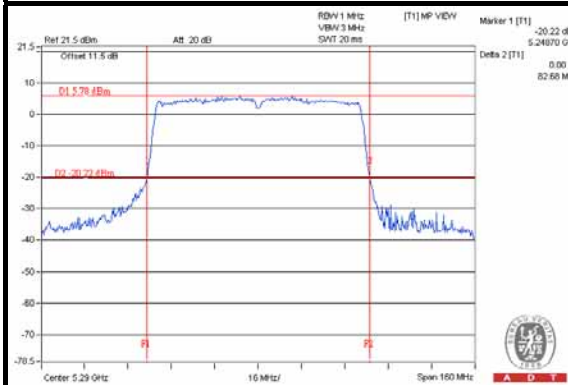

CH106

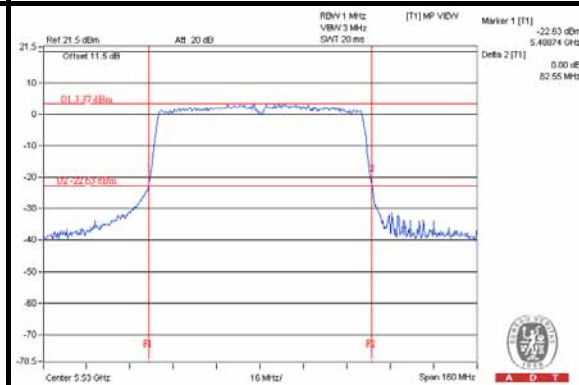

CH138 (UNII-2c Band) / CH138 (UNII-3 Band)

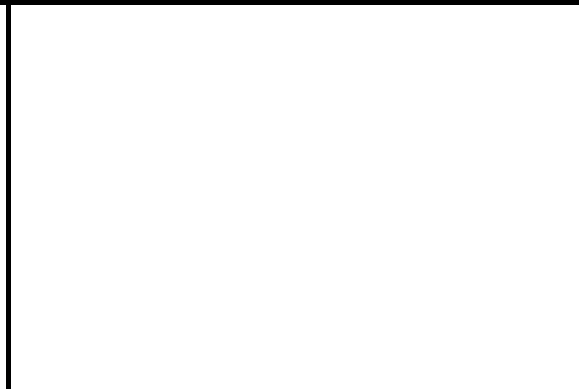
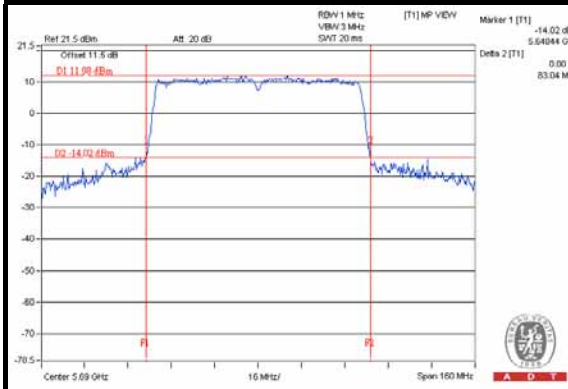

NOTE:

For CH138 (UNII-2c Band) = 5725 - Market 1

For CH138 (UNII-3 Band) = Delta 2 – CH138 (UNII-2c Band) BW



A D T

POWER OUTPUT:

Beamforming (MCS0 NSS=1)_MODE							
CHANNEL	FREQUENCY (MHz)	AVERAGE POWER (dBm)		TOTAL POWER (mW)	TOTAL POWER (dBm)	POWER LIMIT (dBm)	PASS / FAIL
		CHAIN 0	CHAIN 1				
802.11ac (VHT20)							
52	5260	8.56	10.02	17.224	12.36	22.13	PASS
60	5300	8.45	9.91	16.793	12.25	22.13	PASS
64	5320	8.61	10.14	17.589	12.45	22.13	PASS
100	5500	10.71	11.68	26.499	14.23	22.05	PASS
116	5580	14.41	14.51	55.855	17.47	22.05	PASS
132	5660	13.63	13.83	47.222	16.74	22.05	PASS
140	5700	13.35	13.55	44.273	16.46	22.05	PASS
144 (UNII-2c Band)	5720	12.36	14.34	44.383	16.47	20.88	PASS
144 (UNII-3 Band)	5720	6.47	8.48	11.483	10.60	22.29	PASS
802.11ac (VHT40)							
54	5270	12.35	13.07	37.456	15.74	22.13	PASS
62	5310	12.15	13.09	36.776	15.66	22.13	PASS
102	5510	11.46	12.28	30.900	14.90	22.05	PASS
110	5550	13.65	14.53	51.553	17.12	22.05	PASS
134	5670	14.92	14.98	62.523	17.96	22.05	PASS
142 (UNII-2c Band)	5710	14.99	16.90	80.528	19.06	22.05	PASS
142 (UNII-3 Band)	5710	4.43	6.48	7.219	8.58	22.49	PASS



A D T

802.11ac (VHT80)							
58	5290	13.39	14.13	47.709	16.79	22.13	PASS
106	5530	11.17	11.88	28.509	14.55	22.05	PASS
138 (UNII-2c Band)	5690	15.66	17.30	96.912	19.86	22.05	PASS
138 (UNII-3 Band)	5690	1.16	3.29	3.682	5.66	23.18	PASS

For CH138: Average Power (dBm)= measured value(dBm) + Duty Factor (0.3dB)

NOTE:

5250~5350MHz: Directional gain = $10 \log[(10^{G1/20} + 10^{G2/20})^2 / 2] = 7.87\text{dBi} > 6\text{dBi}$, so the power limit shall be reduced to "Determined Conducted Limit-(7.87-6)".

5470~5725MHz (Except for UNII-3 Band): Directional gain = $10 \log[(10^{G1/20} + 10^{G2/20})^2 / 2] = 7.95\text{dBi} > 6\text{dBi}$, so the power limit shall be reduced to "Determined Conducted Limit-(7.95-6)".

5725~5825MHz (For UNII-3 Band): Directional gain = $10 \log[(10^{G1/20} + 10^{G2/20})^2 / 2] = 7.93\text{dBi} > 6\text{dBi}$, so the power limit shall be reduced to "Determined Conducted Limit-(7.93-6)".



26dB OCCUPIED BANDWIDTH:

CHANNEL	CHANNEL FREQUENCY (MHz)	26dBc BANDWIDTH (MHz)	
		CHAIN 0	CHAIN 1
802.11ac (VHT20)			
52	5260	20.81	20.61
60	5300	20.77	20.57
64	5320	20.78	20.55
100	5500	20.68	20.44
116	5580	20.85	20.56
132	5660	20.86	20.62
140	5700	20.75	20.57
144 (UNII-2c Band)	5720	15.26	15.32
144 (UNII-3 Band)	5720	5.29	5.28
802.11ac (VHT40)			
54	5270	41.01	40.62
62	5310	41.17	40.69
102	5510	41.25	40.71
110	5550	40.86	40.71
134	5670	41.12	40.82
142 (UNII-2c Band)	5710	38.88	36.05
142 (UNII-3 Band)	5710	11.01	5.54
802.11ac (VHT80)			
58	5290	83.30	82.68
106	5530	83.00	82.55
138 (UNII-2c Band)	5690	76.90	76.56
138 (UNII-3 Band)	5690	10.48	6.48

Note: For output power limitation is determined based on 26dBc bandwidth.



A D T

Power Limit = 11dBm + 10logB < UNII Band 2~3>			
Channel Number	Freq.(MHz)	Min. B(MHz)	Determined Conducted Limit (dBm)
802.11ac (VHT20)			
52	5260	20.61	24.14 > 24
60	5300	20.57	24.13 > 24
64	5320	20.55	24.12 > 24
100	5500	20.44	24.1 > 24
116	5580	20.56	24.13 > 24
132	5660	20.62	24.14 > 24
140	5700	20.57	24.13 > 24
144 (UNII-2c Band)	5720	15.26	22.83 < 24
144 (UNII-3 Band)	5720	5.28	24.22 < 30
802.11ac (VHT40)			
54	5270	40.62	27.08 > 24
62	5310	40.69	27.09 > 24
102	5510	40.71	27.09 > 24
110	5550	40.71	27.09 > 24
134	5670	40.82	27.1 > 24
142 (UNII-2c Band)	5710	36.05	26.56 > 24
142 (UNII-3 Band)	5710	5.53	24.42 < 30
802.11ac (VHT80)			
58	5290	82.68	30.17 > 24
106	5530	82.55	30.16 > 24
138 (UNII-2c Band)	5690	76.56	29.84 > 24
138 (UNII-3 Band)	5690	6.48	25.11 < 30



A D T

802.11ac (VHT20)

For Chain (0)

CH52

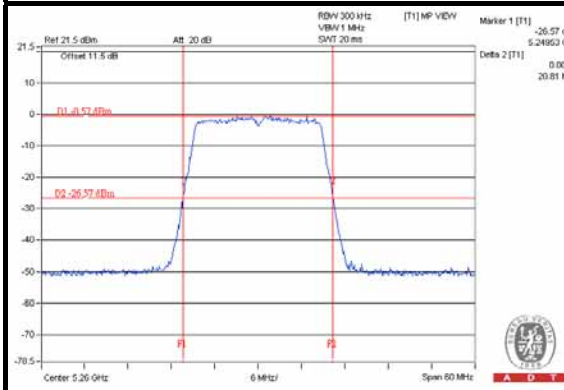

CH60

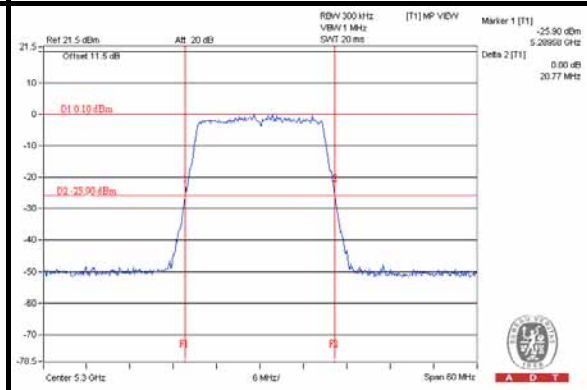

CH64

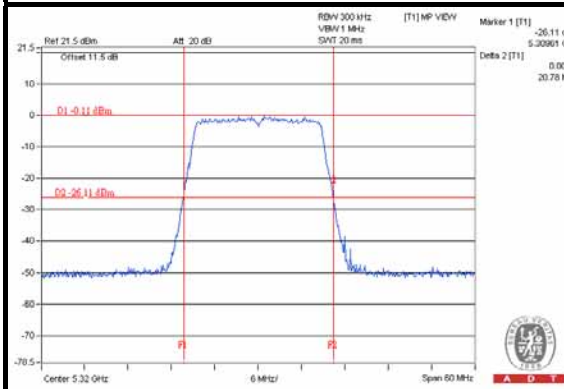

CH100

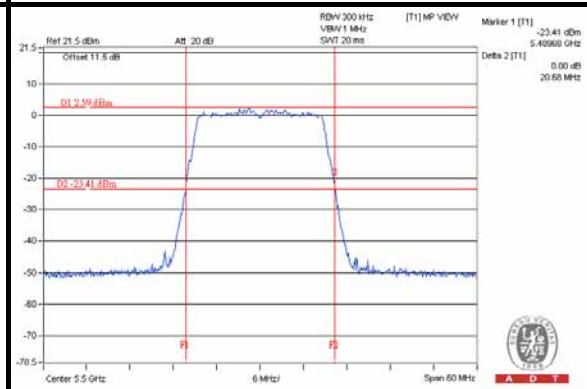

CH116

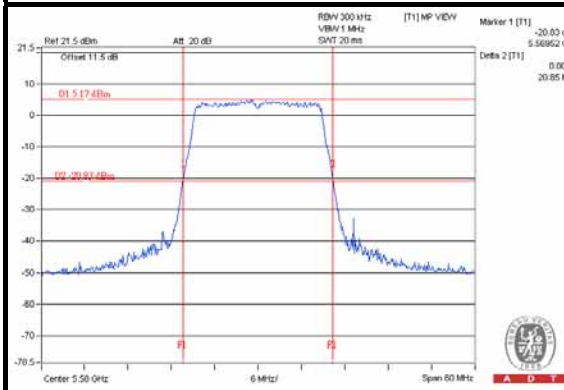

CH132

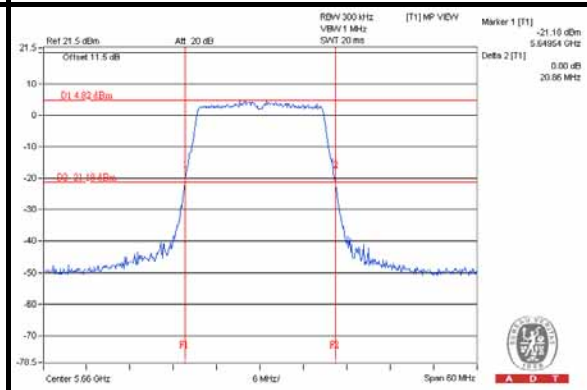



A D T

CH140

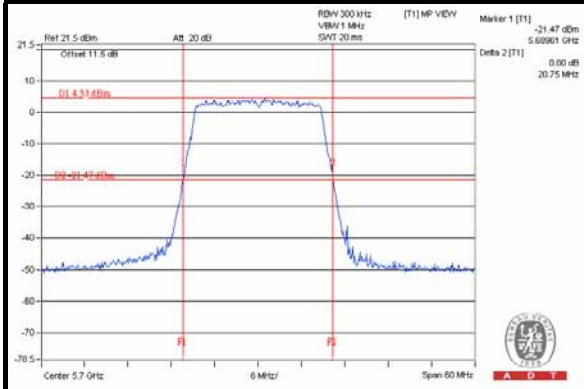

CH144 (UNII-2c Band) / CH144 (UNII-3 Band)

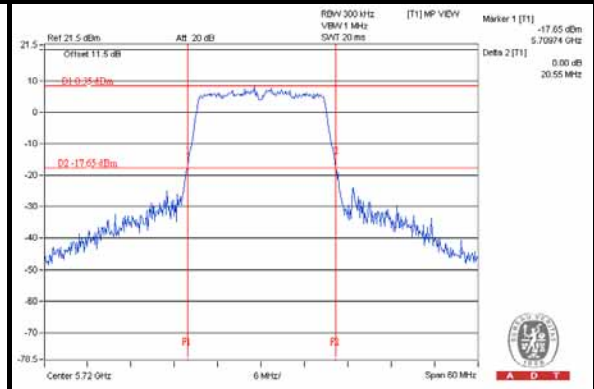

NOTE:

For CH144 (UNII-2c Band) = 5725 - Market 1

For CH144 (UNII-3 Band) = Delta 2 - CH144 (UNII-2c Band) BW



A D T

For Chain (1)

CH52

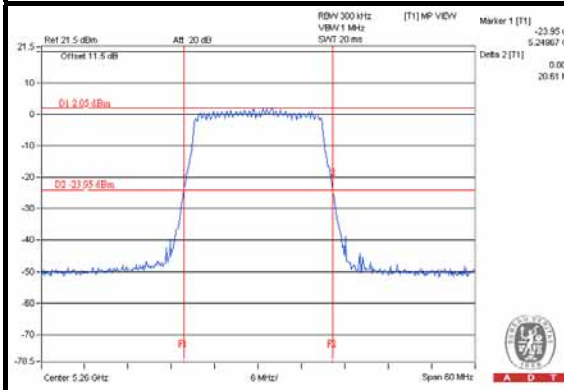

CH60

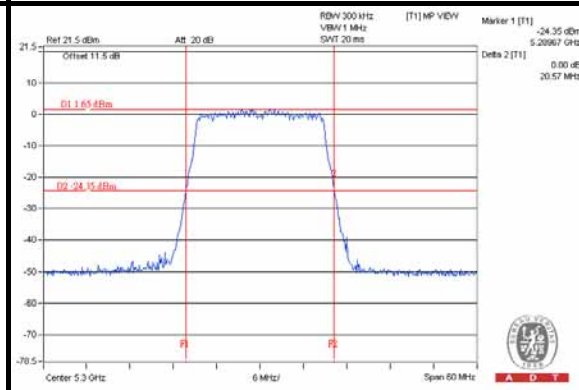

CH64

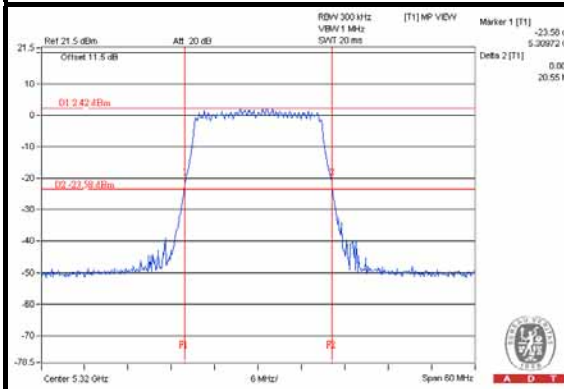

CH100

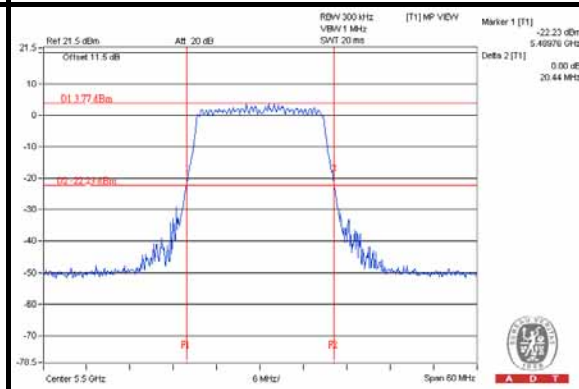

CH116

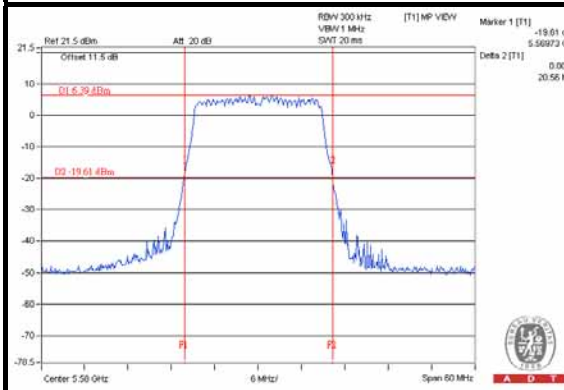

CH132

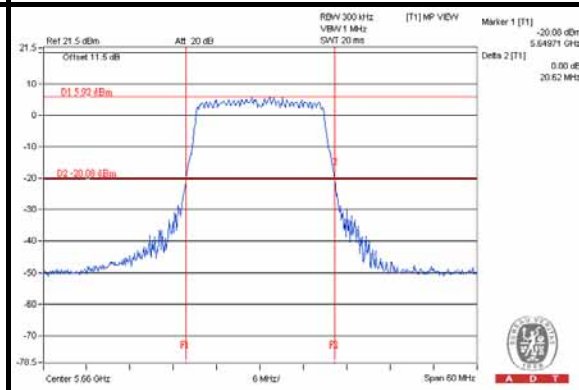



A D T

CH140

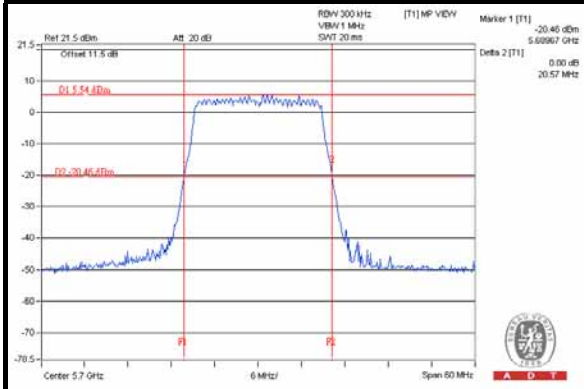

CH144 (UNII-2c Band) / CH144 (UNII-3 Band)

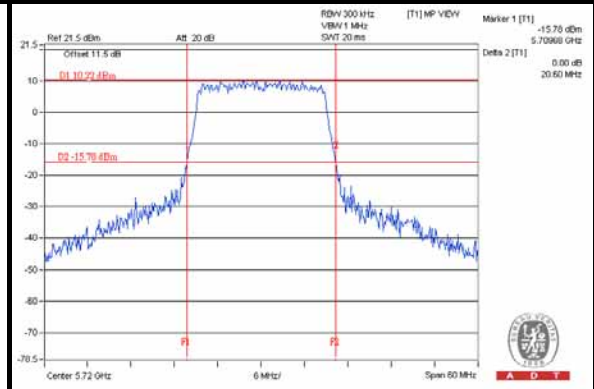

NOTE:

For CH144 (UNII-2c Band) = 5725 - Market 1

For CH144 (UNII-3 Band) = Delta 2 - CH144 (UNII-2c Band) BW



A D T

802.11ac (VHT40)

For Chain (0)

CH54

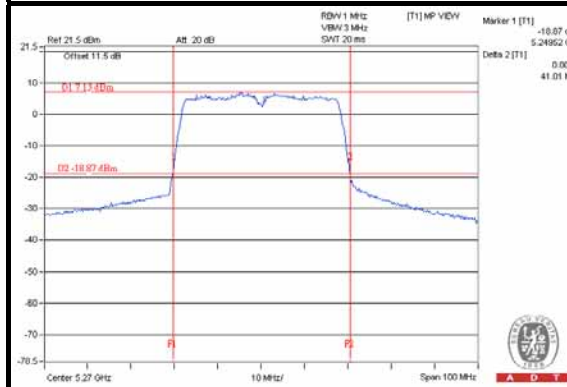

CH62

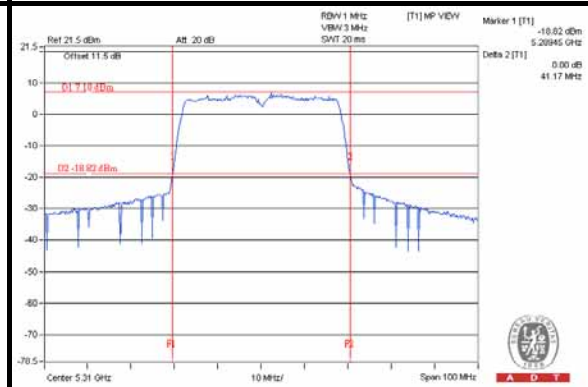

CH102

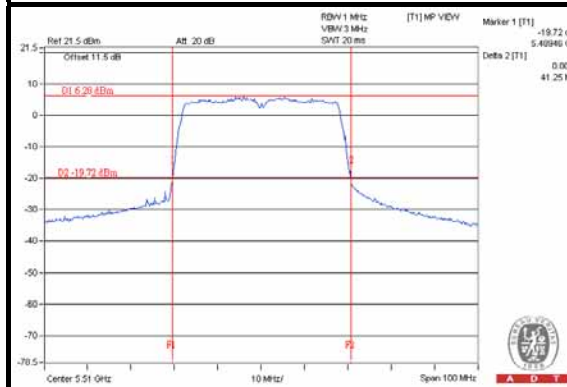

CH110

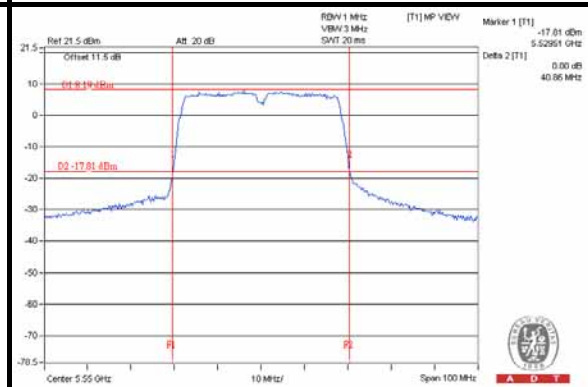

CH134

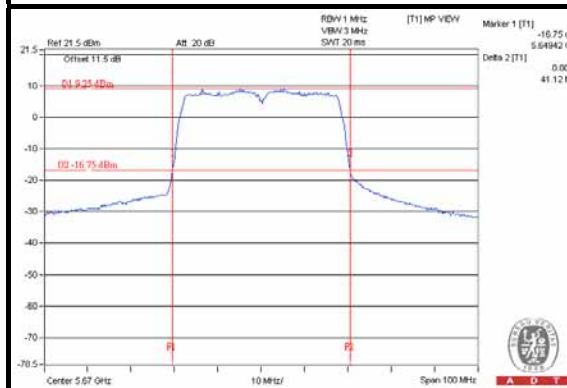

CH142 (UNII-2c Band) / CH142 (UNII-3 Band)

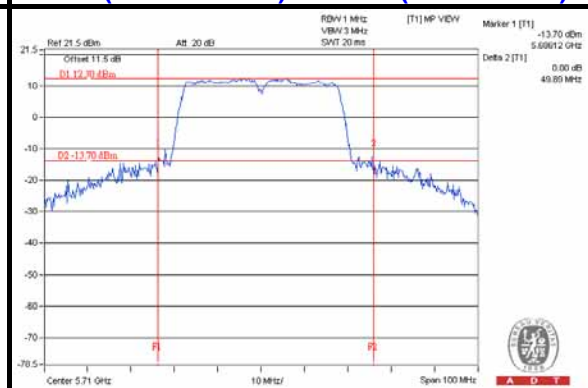

NOTE:

For CH142 (UNII-2c Band) = 5725 - Market 1

For CH142 (UNII-3 Band) = Delta 2 - CH142 (UNII-2c Band) BW



A D T

For Chain (1)

CH54

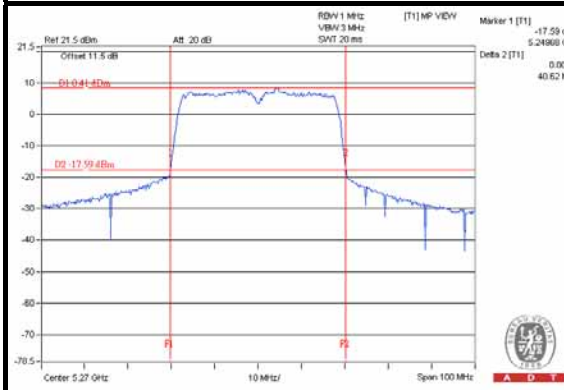

CH62

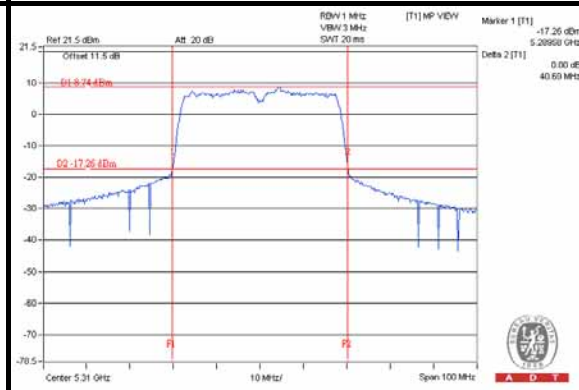

CH102

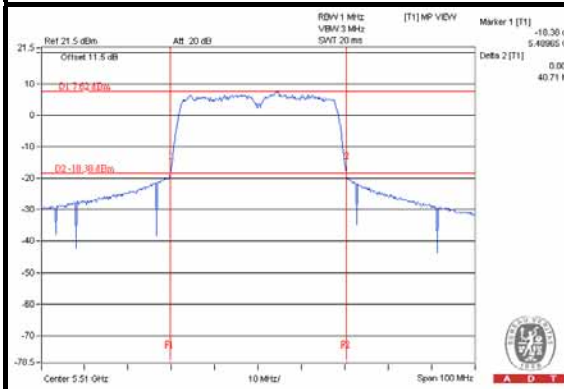

CH110

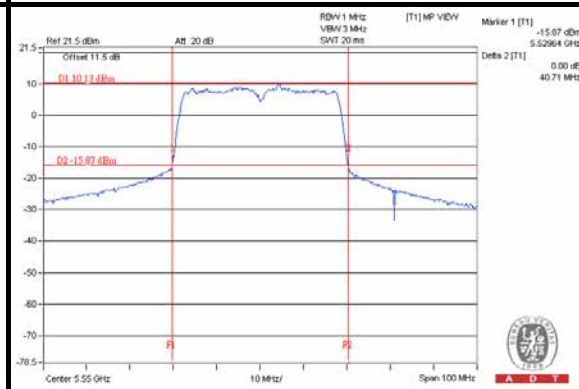

CH134

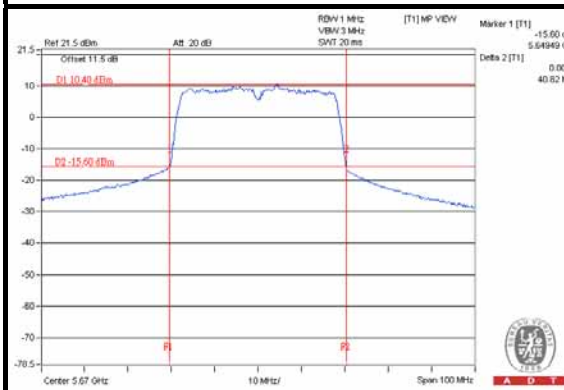

CH142 (UNII-2c Band) / CH142 (UNII-3 Band)

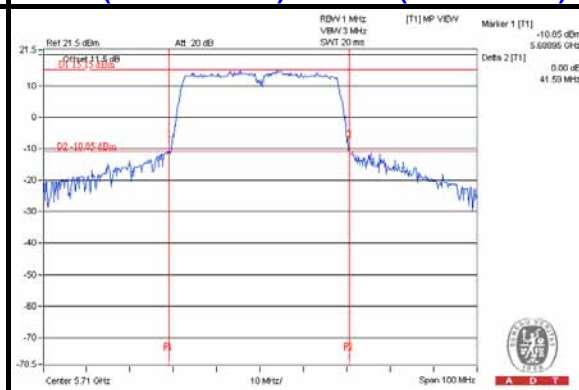

NOTE:

For CH142 (UNII-2c Band) = 5725 - Market 1

For CH142 (UNII-3 Band) = Delta 2 - CH142 (UNII-2c Band) BW



A D T

802.11ac (VHT80)

For Chain (0)

CH58

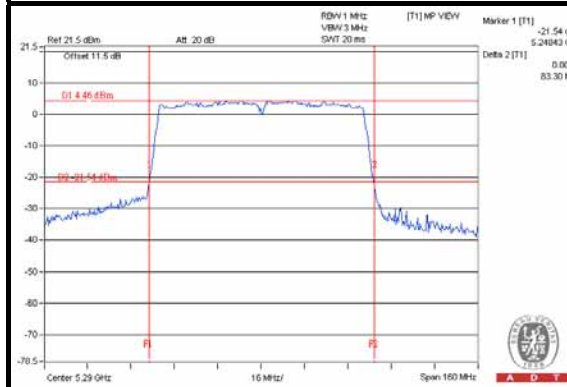

CH106

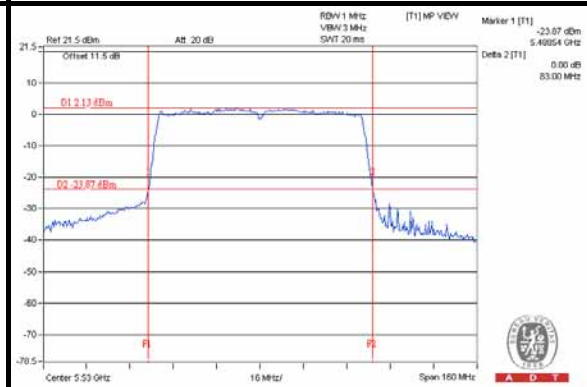

CH138 (UNII-2c Band) / CH138 (UNII-3 Band)

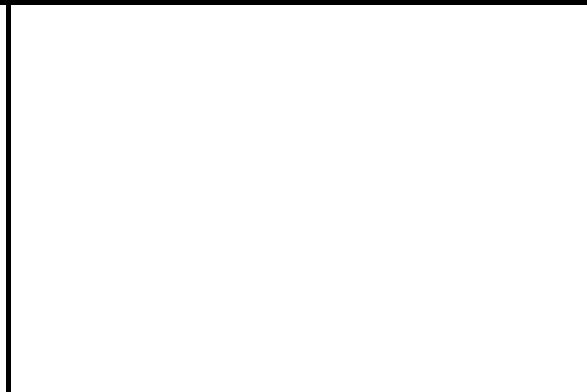
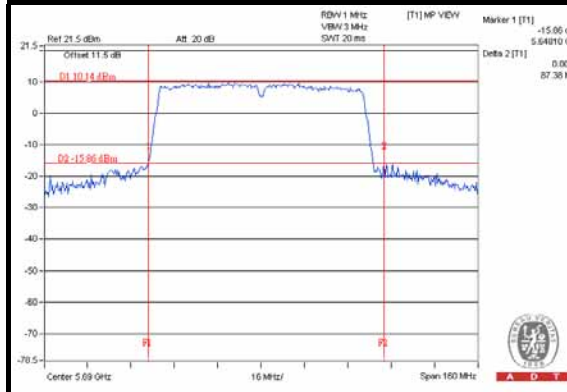

NOTE:

For CH138 (UNII-2c Band) = 5725 - Market 1

For CH138 (UNII-3 Band) = Delta 2 – CH138 (UNII-2c Band) BW



A D T

For Chain (1)

CH58

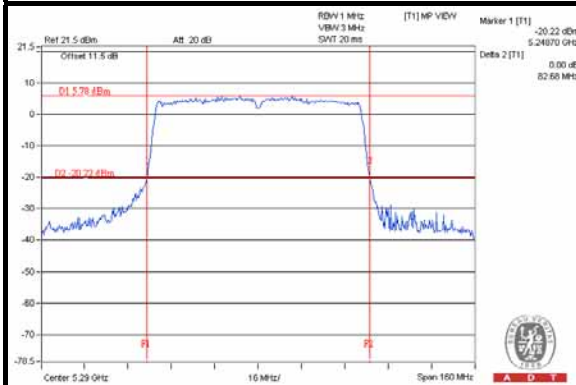

CH106

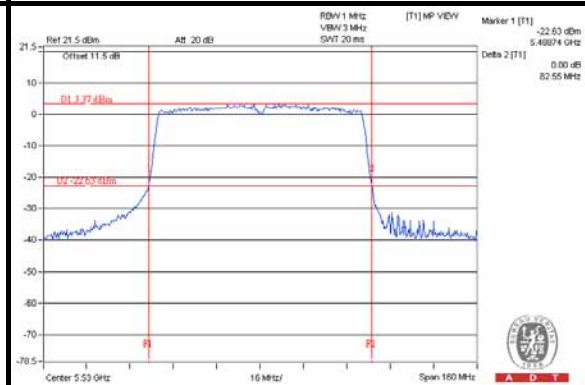

CH138 (UNII-2c Band) / CH138 (UNII-3 Band)

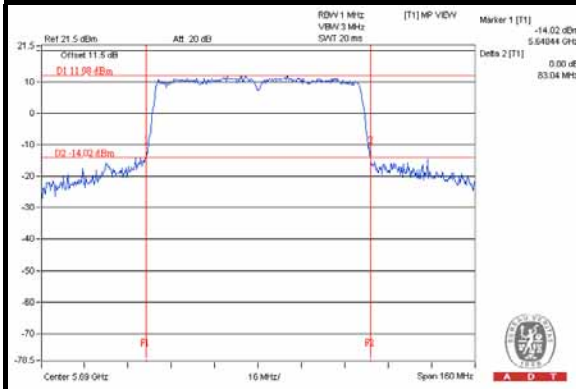

NOTE:

For CH138 (UNII-2c Band) = 5725 - Market 1

For CH138 (UNII-3 Band) = Delta 2 – CH138 (UNII-2c Band) BW



A D T

POWER OUTPUT:

STBC_MODE							
CHANNEL	FREQUENCY (MHz)	AVERAGE POWER (dBm)		TOTAL POWER (mW)	TOTAL POWER (dBm)	POWER LIMIT (dBm)	PASS / FAIL
		CHAIN 0	CHAIN 1				
802.11ac (VHT20)							
52	5260	9.01	10.49	19.156	12.82	24	PASS
60	5300	8.97	9.50	16.802	12.25	24	PASS
64	5320	9.03	10.59	19.453	12.89	24	PASS
100	5500	11.17	12.21	29.726	14.73	24	PASS
116	5580	14.89	15.12	63.341	18.02	24	PASS
132	5660	14.02	14.26	51.904	17.15	24	PASS
140	5700	13.97	14.03	50.239	17.01	24	PASS
144 (UNII-2c Band)	5720	12.36	14.34	44.383	16.47	22.83	PASS
144 (UNII-3 Band)	5720	6.47	8.48	11.483	10.60	24.22	PASS
802.11ac (VHT40)							
54	5270	12.81	13.51	41.538	16.18	24	PASS
62	5310	12.15	13.09	36.776	15.66	24	PASS
102	5510	11.99	12.72	34.519	15.38	24	PASS
110	5550	14.09	15.01	57.341	17.58	24	PASS
134	5670	14.92	14.98	62.523	17.96	24	PASS
142 (UNII-2c Band)	5710	15.66	17.52	93.307	19.70	24	PASS
142 (UNII-3 Band)	5710	5.01	7.14	8.346	9.21	25.38	PASS
802.11ac (VHT80)							
58	5290	15.01	15.79	69.627	18.43	24	PASS
106	5530	11.17	11.88	28.509	14.55	24	PASS
138 (UNII-2c Band)	5690	15.66	17.30	96.912	19.86	24	PASS
138 (UNII-3 Band)	5690	1.16	3.29	3.682	5.66	25.11	PASS
For CH138: Average Power (dBm)= measured value(dBm) + Duty Factor (0.3dB)							



26dB OCCUPIED BANDWIDTH:

CHANNEL	CHANNEL FREQUENCY (MHz)	26dBc BANDWIDTH (MHz)	
		CHAIN 0	CHAIN 1
802.11ac (VHT20)			
52	5260	20.82	20.52
60	5300	20.88	20.62
64	5320	20.62	20.55
100	5500	20.82	20.53
116	5580	20.71	20.58
132	5660	20.81	20.52
140	5700	20.86	20.52
144 (UNII-2c Band)	5720	15.26	15.32
144 (UNII-3 Band)	5720	5.29	5.28
802.11ac (VHT40)			
54	5270	41.03	40.64
62	5310	41.17	40.69
102	5510	41.16	40.71
110	5550	41.18	40.83
134	5670	41.12	40.82
142 (UNII-2c Band)	5710	43.85	44.41
142 (UNII-3 Band)	5710	14.22	6.90
802.11ac (VHT80)			
58	5290	83.05	82.59
106	5530	83.00	82.55
138 (UNII-2c Band)	5690	76.90	76.56
138 (UNII-3 Band)	5690	10.48	6.48

Note: For output power limitation is determined based on 26dBc bandwidth.



A D T

Power Limit = 11dBm + 10logB < UNII Band 2~3>			
Channel Number	Freq.(MHz)	Min. B(MHz)	Determined Conducted Limit (dBm)
802.11ac (VHT20)			
52	5260	20.52	24.12 > 24
60	5300	20.62	24.14 > 24
64	5320	20.55	24.12 > 24
100	5500	20.53	24.12 > 24
116	5580	20.58	24.13 > 24
132	5660	20.52	24.12 > 24
140	5700	20.52	24.12 > 24
144 (UNII-2c Band)	5720	15.26	22.83 < 24
144 (UNII-3 Band)	5720	5.28	24.22 < 30
802.11ac (VHT40)			
54	5270	40.64	27.08 > 24
62	5310	40.69	27.09 > 24
102	5510	40.71	27.09 > 24
110	5550	40.83	27.1 > 24
134	5670	40.82	27.1 > 24
142 (UNII-2c Band)	5710	43.85	27.41 > 24
142 (UNII-3 Band)	5710	6.90	25.38 < 30
802.11ac (VHT80)			
58	5290	82.59	30.16 > 24
106	5530	82.55	30.16 > 24
138 (UNII-2c Band)	5690	76.56	29.84 > 24
138 (UNII-3 Band)	5690	6.48	25.11 < 30



A D T

802.11ac (VHT20)

For Chain (0)

CH52

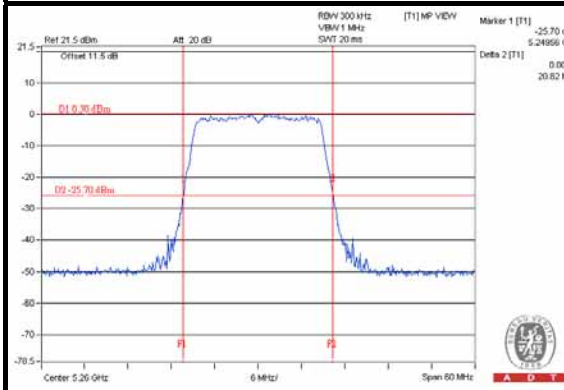

CH60

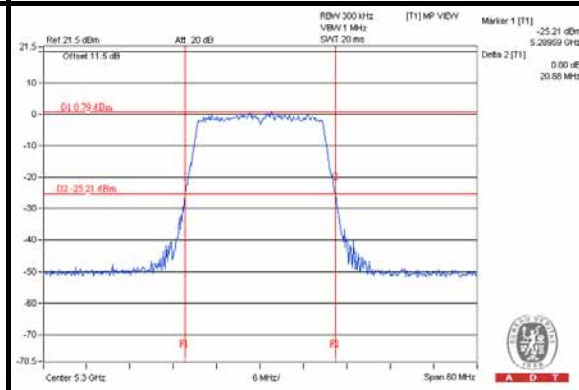

CH64

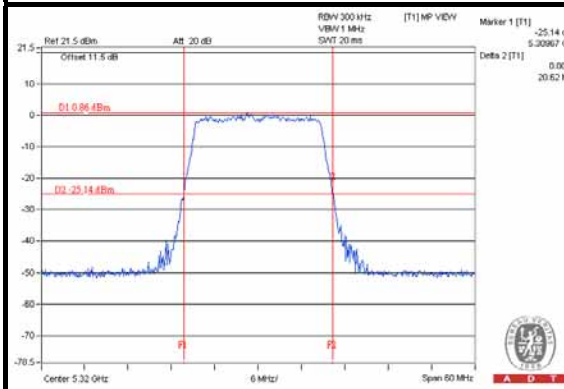

CH100

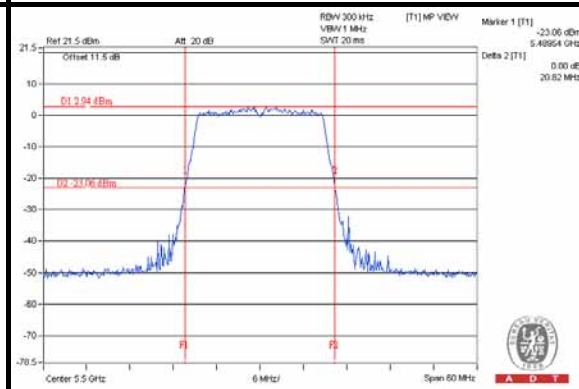

CH116

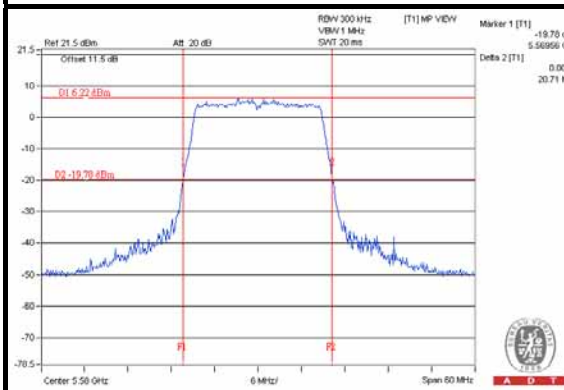

CH132

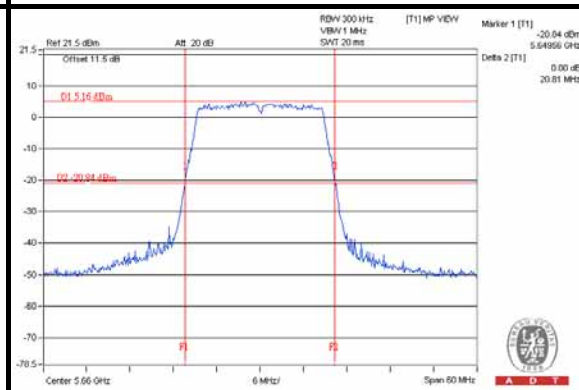



A D T

CH140

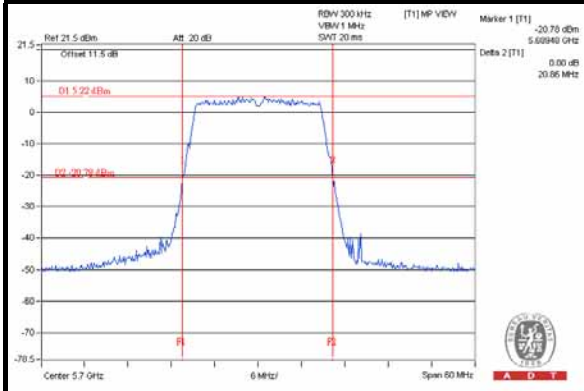

CH144 (UNII-2c Band) / CH144 (UNII-3 Band)

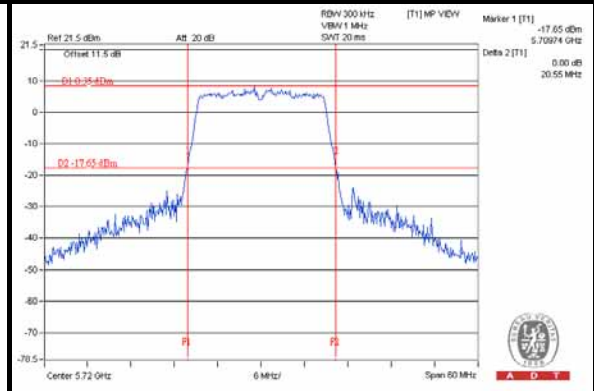

NOTE:

For CH144 (UNII-2c Band) = 5725 - Market 1

For CH144 (UNII-3 Band) = Delta 2 - CH144 (UNII-2c Band) BW



A D T

For Chain (1)

CH52

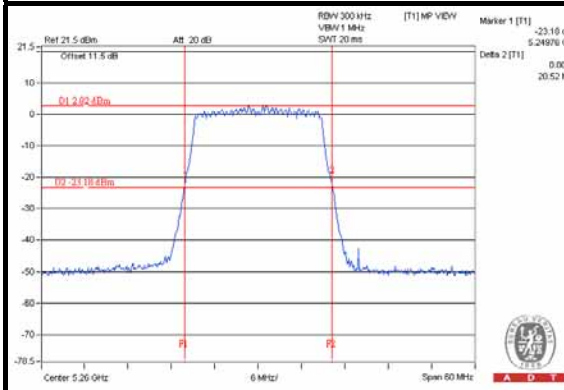

CH60

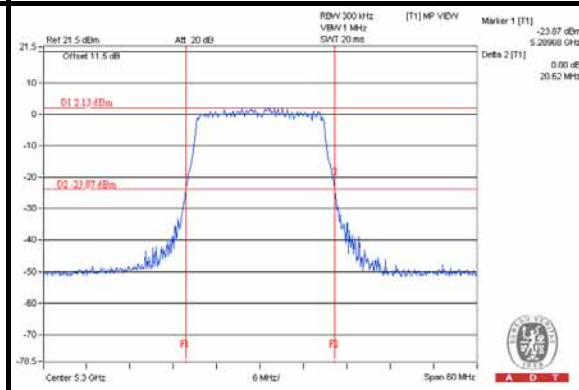

CH64

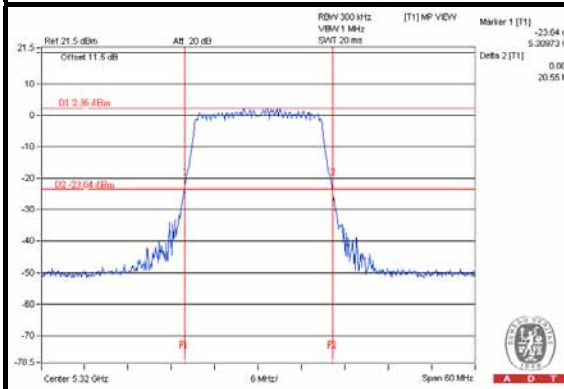

CH100

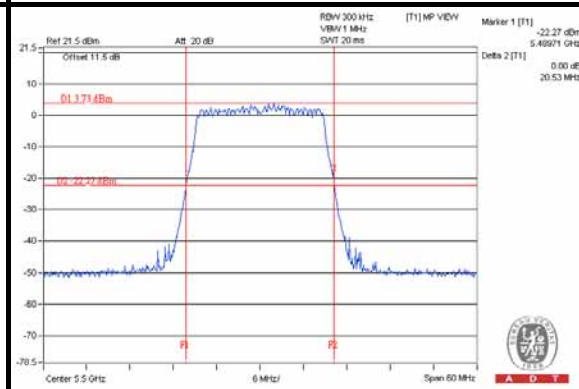

CH116

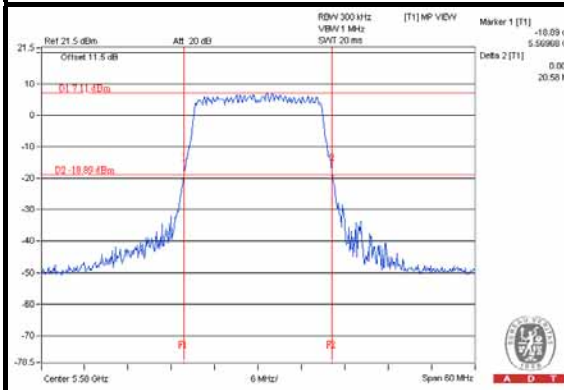

CH132

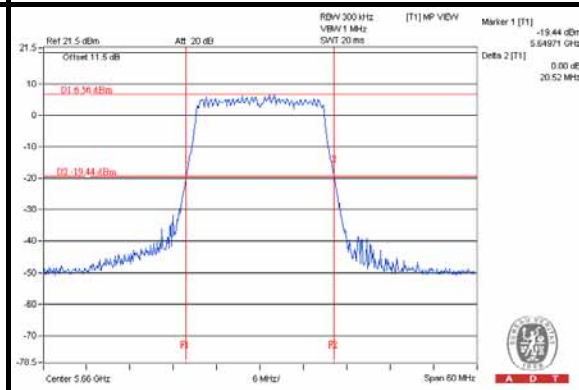



A D T

CH140

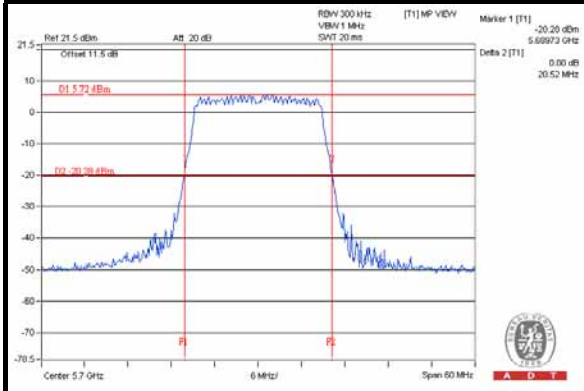

CH144 (UNII-2c Band) / CH144 (UNII-3 Band)

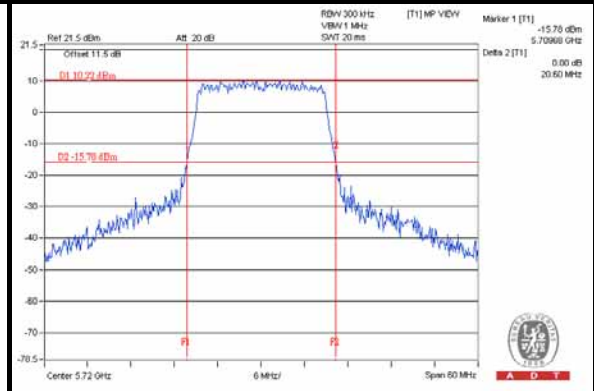

NOTE:

For CH144 (UNII-2c Band) = 5725 - Market 1

For CH144 (UNII-3 Band) = Delta 2 - CH144 (UNII-2c Band) BW



A D T

802.11ac (VHT40)

For Chain (0)

CH54

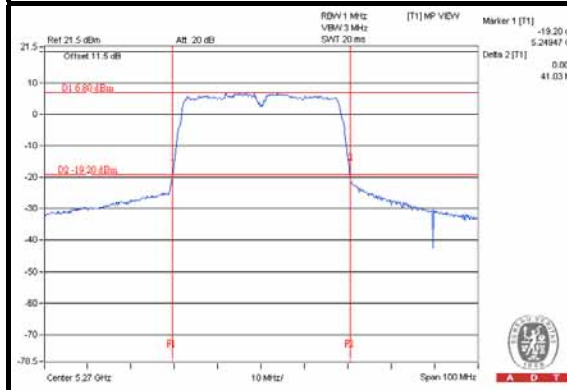

CH62

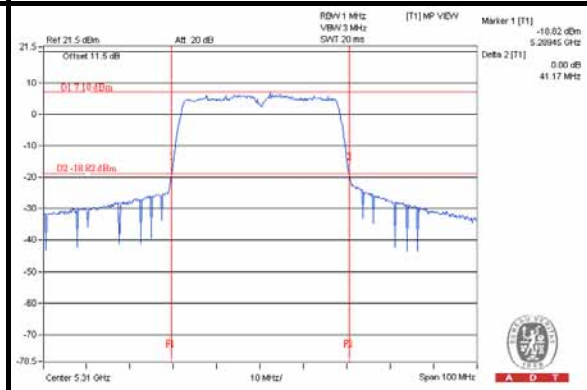

CH102

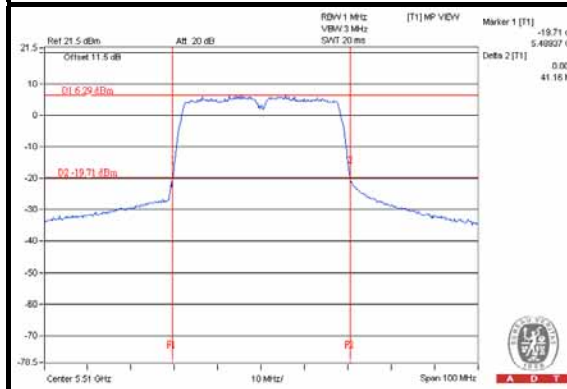

CH110

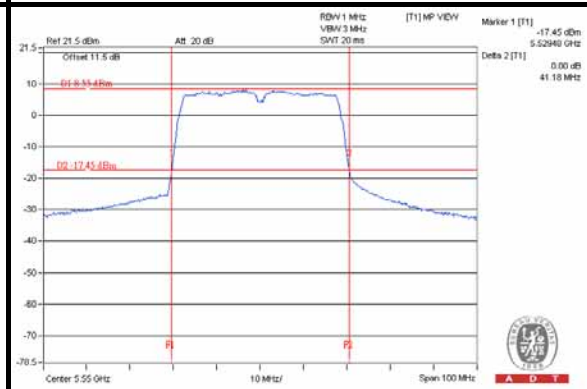

CH134

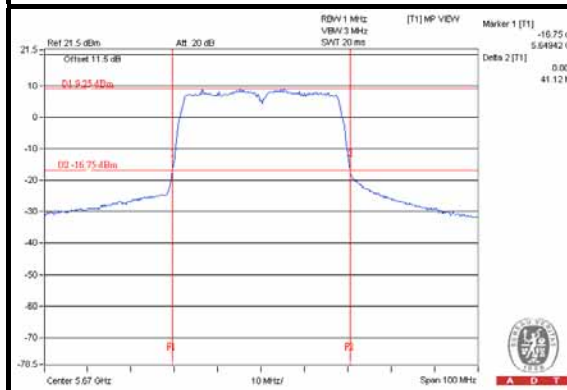

CH142 (UNII-2c Band) / CH142 (UNII-3 Band)

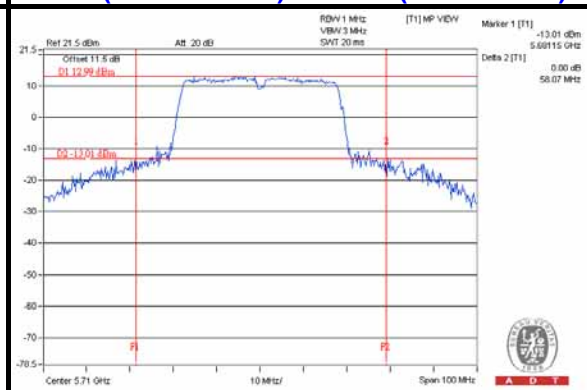

NOTE:

For CH142 (UNII-2c Band) = 5725 - Market 1

For CH142 (UNII-3 Band) = Delta 2 - CH142 (UNII-2c Band) BW



A D T

For Chain (1)

CH54

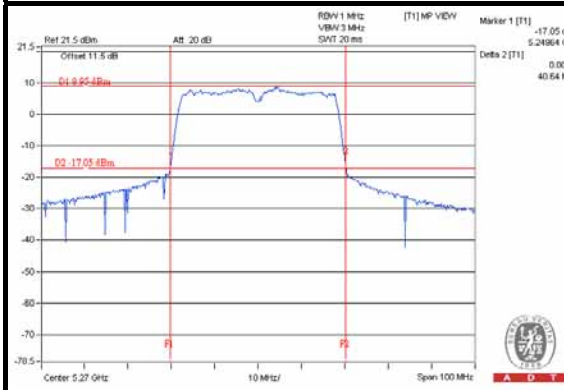

CH62

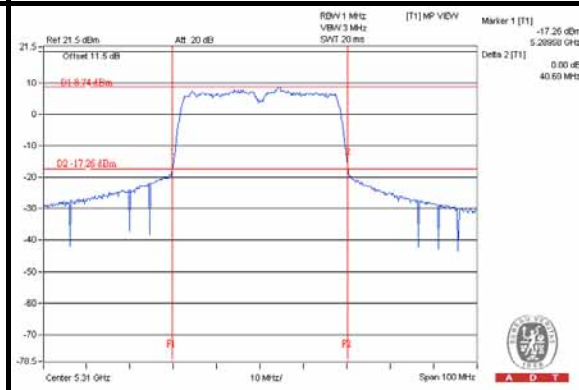

CH102

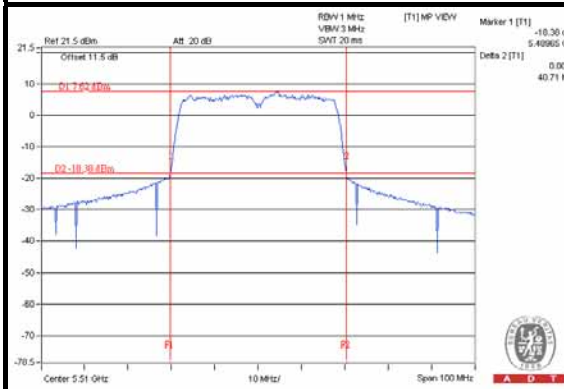

CH110

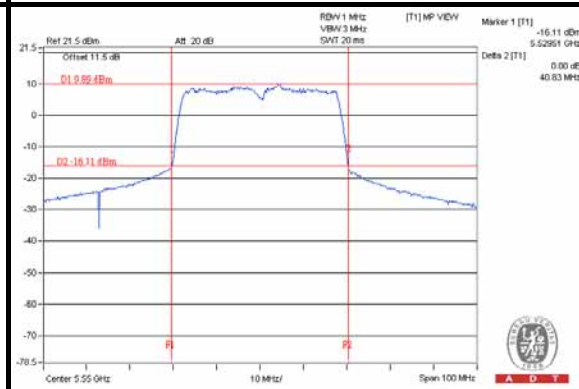

CH134

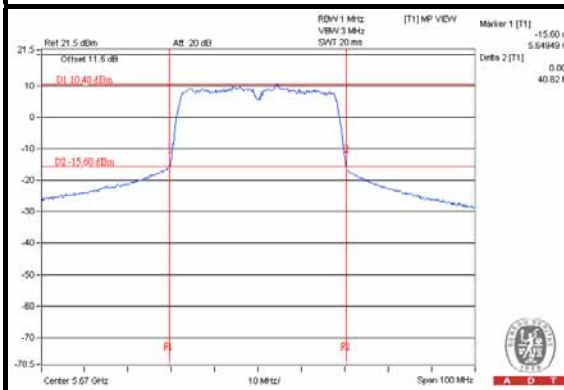

CH142 (UNII-2c Band) / CH142 (UNII-3 Band)

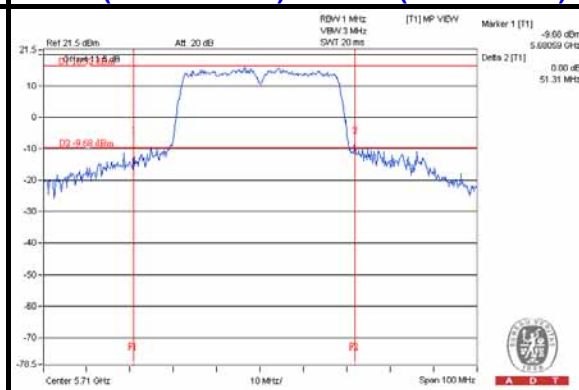

NOTE:

For CH142 (UNII-2c Band) = 5725 - Market 1

For CH142 (UNII-3 Band) = Delta 2 - CH142 (UNII-2c Band) BW



A D T

802.11ac (VHT80)

For Chain (0)

CH58

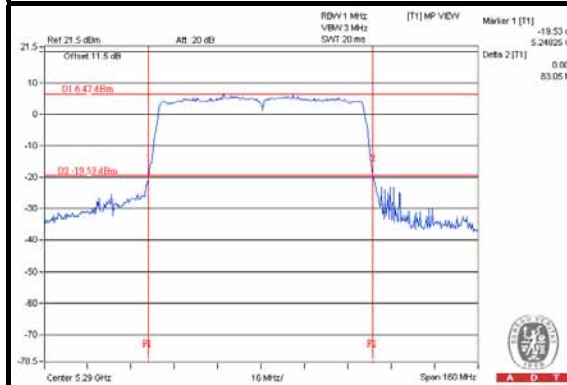

CH106

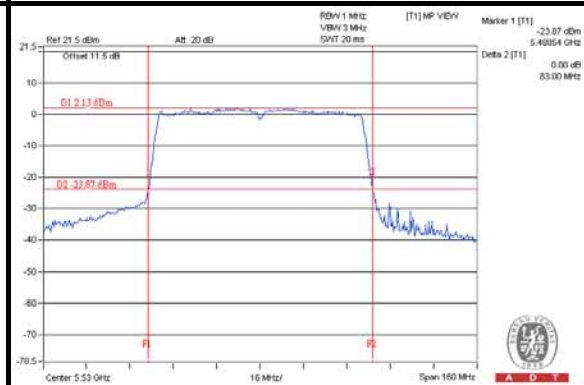

CH138 (UNII-2c Band) / CH138 (UNII-3 Band)

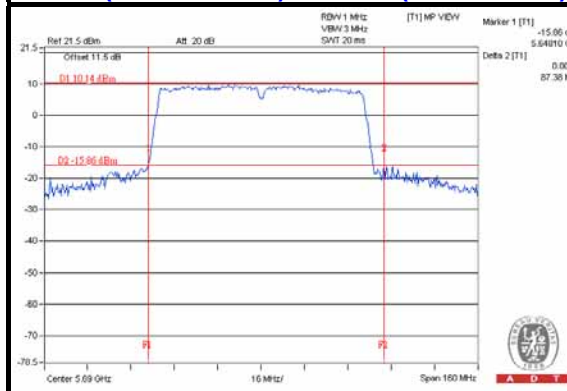

NOTE:

For CH138 (UNII-2c Band) = 5725 - Market 1

For CH138 (UNII-3 Band) = Delta 2 – CH138 (UNII-2c Band) BW



A D T

For Chain (1)

CH58

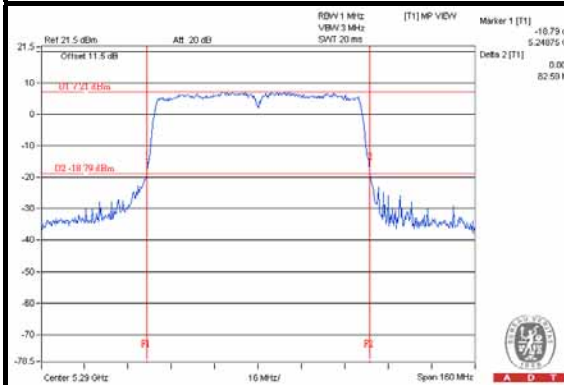

CH106

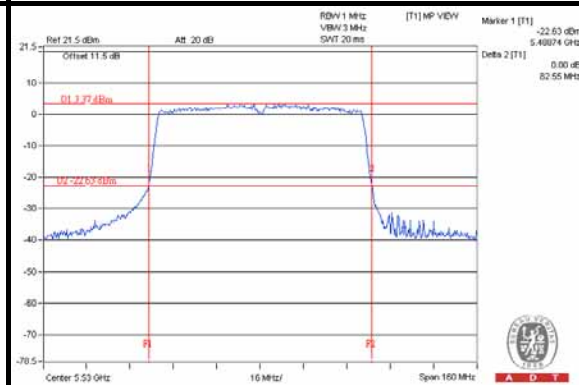

CH138 (UNII-2c Band) / CH138 (UNII-3 Band)

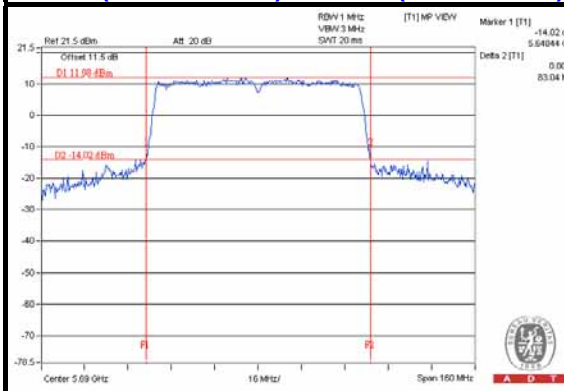

NOTE:

For CH138 (UNII-2c Band) = 5725 - Market 1

For CH138 (UNII-3 Band) = Delta 2 – CH138 (UNII-2c Band) BW



A D T

4.3.9 TEST RESULTS (MODE 3)

POWER OUTPUT:

802.11a					
CHANNEL	CHANNEL FREQUENCY (MHz)	AVERAGE POWER (mW)	AVERAGE POWER (dBm)	POWER LIMIT (dBm)	PASS/FAIL
52	5260	7.834	8.94	24	PASS
60	5300	6.166	7.90	24	PASS
64	5320	6.026	7.80	24	PASS
100	5500	12.190	10.86	24	PASS
116	5580	14.028	11.47	24	PASS
132	5660	11.614	10.65	24	PASS
140	5700	11.402	10.57	24	PASS
144 (UNII-2c Band)	5720	12.474	10.96	22.86	PASS
144 (UNII-3 Band)	5720	2.838	4.53	24.22	PASS

26dB OCCUPIED BANDWIDTH:

CHANNEL	CHANNEL FREQUENCY (MHz)	26dBc BANDWIDTH (MHz)
52	5260	20.35
60	5300	20.57
64	5320	20.53
100	5500	20.49
116	5580	20.53
132	5660	20.52
140	5700	20.50
144 (UNII-2c Band)	5720	15.35
144 (UNII-3 Band)	5720	5.28

Note: For output power limitation is determined based on 26dBc bandwidth.



A D T

Power Limit = 11dBm + 10logB < UNII Band 2~3>			
Channel Number	Freq.(MHz)	Min. B(MHz)	Determined Conducted Limit (dBm)
52	5260	20.35	24.08 > 24
60	5300	20.57	24.13 > 24
64	5320	20.53	24.12 > 24
100	5500	20.49	24.11 > 24
116	5580	20.53	24.12 > 24
132	5660	20.52	24.12 > 24
140	5700	20.50	24.11 > 24
144 (UNII-2c Band)	5720	15.35	22.86 < 24
144 (UNII-3 Band)	5720	5.28	24.22 < 30



A D T

802.11a

CH52

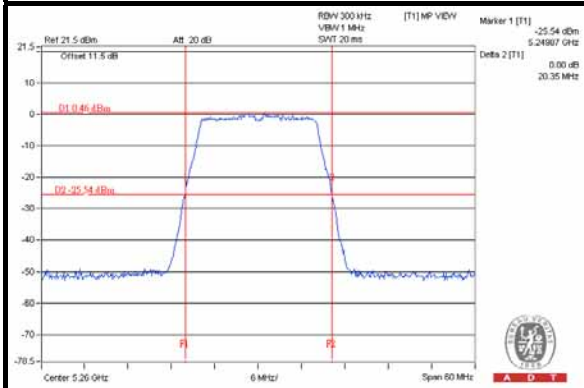

CH60

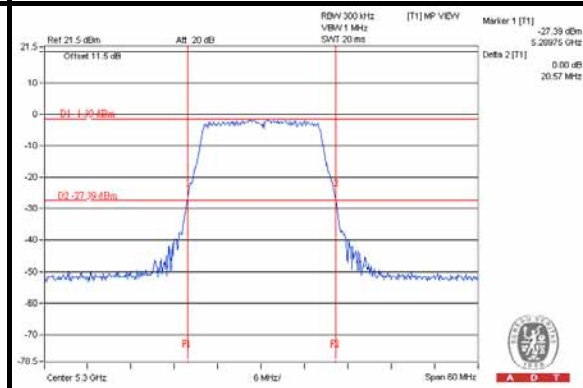

CH64

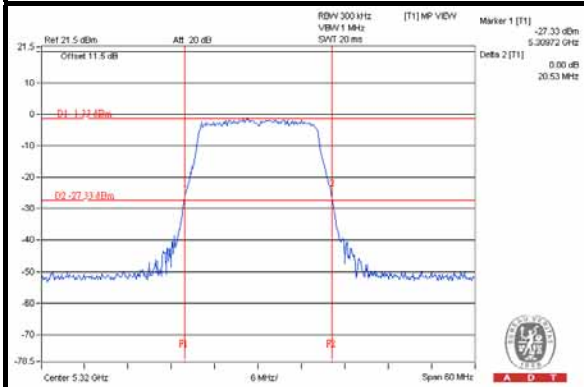

CH100

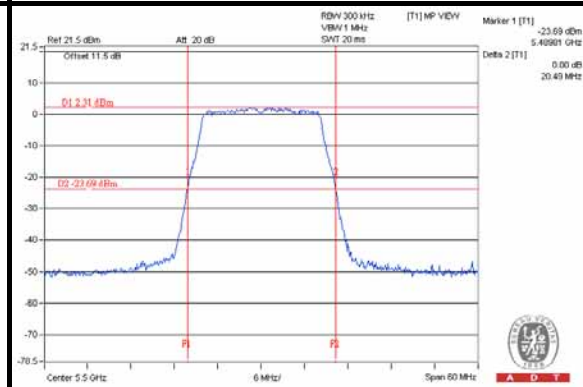

CH116

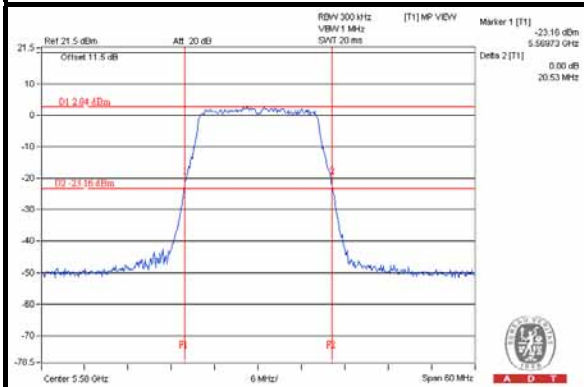

CH132

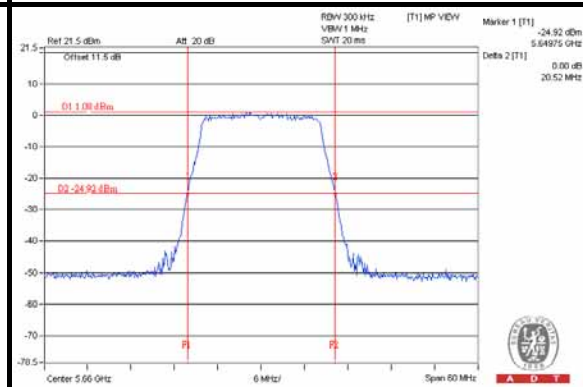



A D T

CH140

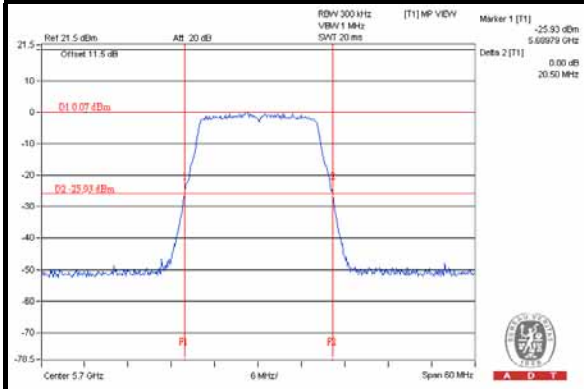

CH144 (UNII-2c Band) / CH144 (UNII-3 Band)

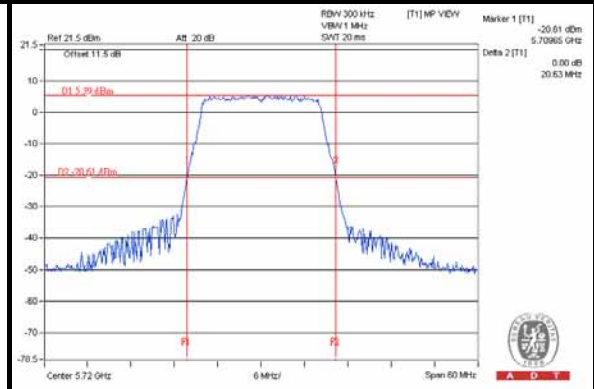

NOTE:

For CH144 (UNII-2c Band) = 5725 - Market 1

For CH144 (UNII-3 Band) = Delta 2 - CH144 (UNII-2c Band) BW



A D T

4.4 PEAK POWER SPECTRAL DENSITY MEASUREMENT

4.4.1 LIMITS OF PEAK POWER SPECTRAL DENSITY MEASUREMENT

Frequency Band	Limit
5.15 ~ 5.25GHz	4dBm
5.25 ~ 5.35GHz	11dBm
5.47 – 5.725GHz	11dBm
5.725 ~ 5.825GHz	17dBm

4.4.2 TEST INSTRUMENTS

DESCRIPTION & MANUFACTURER	MODEL NO.	SERIAL NO.	CALIBRATED DATE	CALIBRATED UNTIL
SPECTRUM ANALYZER R&S	FSV 40	100964	July 15, 2013	July 14, 2014

Note:

1. The calibration interval of the above test instruments is 12 months and the calibrations are traceable to NML/ROC and NIST/USA.
2. Tested date : May 05, 2014

4.4.3 TEST PROCEDURES

1. Set span to encompass the entire emission bandwidth (EBW) of the signal.
2. Set RBW = 1 MHz, Set VBW \geq 3 MHz, Detector = RMS
3. Sweep time = auto, trigger set to “free run”.
4. Trace average at least 100 traces in power averaging mode.
5. Record the max value and for duty cycle of test signal is < 98% add 10 log (1/duty cycle)

4.4.4 DEVIATION FROM TEST STANDARD

No deviation



A D T

4.4.5 TEST SETUP

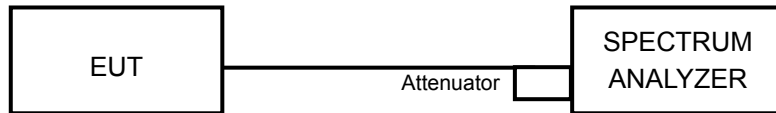

4.4.6 EUT OPERATING CONDITIONS

Same as 4.3.6



4.4.7 TEST RESULTS (MODE 1)

CDD, Beam forming (MCS0 NSS=1)_MODE

802.11ac (VHT20)							
CHANNEL	CHANNEL FREQUENCY (MHz)	PSD (dBm)			TOTAL POWER DENSITY (dBm)	MAX. LIMIT (dBm)	PASS/FAIL
		CHAIN 0	CHAIN 1	CHAIN 2			
52	5260	-8.10	-5.73	-8.93	-2.60	7.54	PASS
60	5300	-8.11	-5.64	-10.41	-2.85	7.54	PASS
64	5320	-8.40	-5.14	-10.57	-2.69	7.54	PASS
100	5500	-6.20	-5.45	-4.98	-0.74	7.48	PASS
116	5580	-2.04	-1.82	-1.71	2.92	7.48	PASS
132	5660	-5.21	-4.28	-3.32	0.57	7.48	PASS
140	5700	-5.84	-3.96	-3.56	0.43	7.48	PASS
144 (UNII-2c Band)	5720	2.33	2.69	2.50	7.28	7.48	PASS
144 (UNII-3 Band)	5720	0.92	2.42	1.16	6.32	13.54	PASS
NOTE:	<p>1. Method a) of power density measurement of KDB 662911 is using for calculating total power density. Total power density is summing entire spectra across corresponding frequency bins on the various outputs by computer.</p> <p>2. 5250~5350MHz: Directional gain = $10 \log[(10^{G1/20} + 10^{G2/20} + 10^{G3/20})^2 / 3] = 9.46\text{dBi} > 6\text{dBi}$, so the power density limit shall be reduced to $11-(9.46-6) = 7.54\text{dBm}$.</p> <p>5470~5725MHz (Except for UNII-3 Band): Directional gain = $10 \log[(10^{G1/20} + 10^{G2/20} + 10^{G3/20})^2 / 3] = 9.52\text{dBi} > 6\text{dBi}$, so the power density limit shall be reduced to $11-(9.52-6) = 7.48\text{dBm}$.</p> <p>5725~5825MHz (For UNII-3 Band): Directional gain = $10 \log[(10^{G1/20} + 10^{G2/20} + 10^{G3/20})^2 / 3] = 9.46\text{dBi} > 6\text{dBi}$, so the power density limit shall be reduced to $17-(9.46-6) = 13.54\text{dBm}$.</p>						



802.11ac (VHT40)

CHANNEL	CHANNEL FREQUENCY (MHz)	PSD (dBm)			TOTAL POWER DENSITY (dBm)	MAX. LIMIT (dBm)	PASS/FAIL
		CHAIN 0	CHAIN 1	CHAIN 2			
54	5270	-6.30	-5.35	-7.18	-1.44	7.54	PASS
62	5310	-7.87	-6.47	-9.61	-3.03	7.54	PASS
102	5510	-6.23	-5.59	-5.40	-0.95	7.48	PASS
110	5550	-4.85	-5.10	-3.96	0.16	7.48	PASS
134	5670	-7.85	-6.61	-5.94	-1.96	7.48	PASS
142 (UNII-2c Band)	5710	-1.63	-0.96	-0.35	3.82	7.48	PASS
142 (UNII-3 Band)	5710	-2.85	-2.12	-1.52	2.64	13.54	PASS
NOTE:	<p>1. Method a) of power density measurement of KDB 662911 is using for calculating total power density. Total power density is summing entire spectra across corresponding frequency bins on the various outputs by computer.</p> <p>2. 5250~5350MHz: Directional gain = $10 \log[(10^{G1/20} + 10^{G2/20} + 10^{G3/20})^2 / 3] = 9.46\text{dBi}$ > 6dBi , so the power density limit shall be reduced to $11-(9.46-6) = 7.54\text{dBm}$.</p> <p>5470~5725MHz (Except for UNII-3 Band): Directional gain = $10 \log[(10^{G1/20} + 10^{G2/20} + 10^{G3/20})^2 / 3] = 9.52\text{dBi}$ > 6dBi , so the power density limit shall be reduced to $11-(9.52-6) = 7.48\text{dBm}$.</p> <p>5725~5825MHz (For UNII-3 Band): Directional gain = $10 \log[(10^{G1/20} + 10^{G2/20} + 10^{G3/20})^2 / 3] = 9.46\text{dBi}$ > 6dBi , so the power density limit shall be reduced to $17-(9.46-6) = 13.54\text{dBm}$.</p>						



802.11ac (VHT80)								
CHANNEL	CHANNEL FREQUENCY (MHz)	PSD W/O DUTY FACTOR (dBm)			DUTY FACTOR (dB)	TOTAL PSD WITH DUTY FACTOR (dBm)	MAX. LIMIT (dBm)	PASS/FAIL
		CHAIN 0	CHAIN 1	CHAIN 2				
58	5290	-8.62	-7.97	-9.45	0.15	-3.72	7.54	PASS
106	5530	-10.96	-10.20	-10.05	0.15	-5.46	7.48	PASS
138 (UNII-2c Band)	5690	-5.17	-4.70	-3.82	0.15	0.39	7.48	PASS
138 (UNII-3 Band)	5690	-6.73	-5.37	-5.78	0.15	-1.00	13.54	PASS
NOTE:	<p>1. Method a) of power density measurement of KDB 662911 is using for calculating total power density. Total power density is summing entire spectra across corresponding frequency bins on the various outputs by computer.</p> <p>2. 5250~5350MHz: Directional gain = $10 \log[(10^{G1/20} + 10^{G2/20} + 10^{G3/20})^2 / 3]$ = 9.46dBi > 6dBi , so the power density limit shall be reduced to 11-(9.46-6) = 7.54dBm.</p> <p>5470~5725MHz (Except for UNII-3 Band): Directional gain = $10 \log[(10^{G1/20} + 10^{G2/20} + 10^{G3/20})^2 / 3]$ = 9.52dBi > 6dBi , so the power density limit shall be reduced to 11-(9.52-6) = 7.48dBm.</p> <p>5725~5825MHz (For UNII-3 Band): Directional gain = $10 \log[(10^{G1/20} + 10^{G2/20} + 10^{G3/20})^2 / 3]$ = 9.46dBi > 6dBi , so the power density limit shall be reduced to 17-(9.46-6) = 13.54dBm.</p> <p>3. Refer to section 3.4 for duty cycle spectrum plot.</p>							

**SDM, Beam forming (MCS0 NSS=3)_MODE****802.11ac (VHT20)**

CHANNEL	CHANNEL FREQUENCY (MHz)	PSD (dBm)			TOTAL POWER DENSITY (dBm)	MAX. LIMIT (dBm)	PASS/FAIL
		CHAIN 0	CHAIN 1	CHAIN 2			
52	5260	-8.10	-5.73	-8.93	-2.60	11	PASS
60	5300	-8.11	-5.64	-10.41	-2.85	11	PASS
64	5320	-8.40	-5.14	-10.57	-2.69	11	PASS
100	5500	-6.20	-5.45	-4.98	-0.74	11	PASS
116	5580	-2.04	-1.82	-1.71	2.92	11	PASS
132	5660	-5.21	-4.28	-3.32	0.57	11	PASS
140	5700	-5.84	-3.96	-3.56	0.43	11	PASS
144 (UNII-2c Band)	5720	2.33	2.69	2.50	7.28	11	PASS
144 (UNII-3 Band)	5720	0.92	2.42	1.16	6.32	17	PASS

NOTE:

1. Method a) of power density measurement of KDB 662911 is using for calculating total power density. Total power density is summing entire spectra across corresponding frequency bins on the various outputs by computer.
2. The SDM mode is non-correlated mode.
3. For Beam forming (MCS0 NSS=3) Mode:
5250~5350MHz: Directional gain = maximum gain of antennas + $10 \log(3/3) = 5.75\text{dBi} < 6\text{dBi}$, so the power density limit shall not be reduced.
5470~5725MHz (Except for UNII-3 Band): Directional gain = maximum gain of antennas + $10 \log(3/3) = 5.75\text{dBi} < 6\text{dBi}$, so the power density limit shall not be reduced.
5725~5825MHz (For UNII-3 Band): Directional gain = maximum gain of antennas + $10 \log(3/3) = 5.71\text{dBi} < 6\text{dBi}$, so the power density limit shall not be reduced.



A D T

802.11ac (VHT40)

CHANNEL	CHANNEL FREQUENCY (MHz)	PSD (dBm)			TOTAL POWER DENSITY (dBm)	MAX. LIMIT (dBm)	PASS/FAIL
		CHAIN 0	CHAIN 1	CHAIN 2			
54	5270	-6.30	-5.35	-7.18	-1.44	11	PASS
62	5310	-7.87	-6.47	-9.61	-3.03	11	PASS
102	5510	-6.23	-5.59	-5.40	-0.95	11	PASS
110	5550	-4.85	-5.10	-3.96	0.16	11	PASS
134	5670	-7.85	-6.61	-5.94	-1.96	11	PASS
142 (UNII-2c Band)	5710	-1.63	-0.96	-0.35	3.82	11	PASS
142 (UNII-3 Band)	5710	-2.85	-2.12	-1.52	2.64	17	PASS

NOTE:

1. Method a) of power density measurement of KDB 662911 is using for calculating total power density. Total power density is summing entire spectra across corresponding frequency bins on the various outputs by computer.
2. The SDM mode is non-correlated mode.
3. For Beam forming (MCS0 NSS=3) Mode:
5250~5350MHz: Directional gain = maximum gain of antennas + $10 \log(3/3) = 5.75\text{dBi} < 6\text{dBi}$, so the power density limit shall not be reduced.
5470~5725MHz (Except for UNII-3 Band): Directional gain = maximum gain of antennas + $10 \log(3/3) = 5.75\text{dBi} < 6\text{dBi}$, so the power density limit shall not be reduced.
5725~5825MHz (For UNII-3 Band): Directional gain = maximum gain of antennas + $10 \log(3/3) = 5.71\text{dBi} < 6\text{dBi}$, so the power density limit shall not be reduced.



802.11ac (VHT80)								
CHANNEL	CHANNEL FREQUENCY (MHz)	PSD W/O DUTY FACTOR (dBm)			DUTY FACTOR (dB)	TOTAL PSD WITH DUTY FACTOR (dBm)	MAX. LIMIT (dBm)	PASS/FAIL
		CHAIN 0	CHAIN 1	CHAIN 2				
58	5290	-8.62	-7.97	-9.45	0.15	-3.72	11	PASS
106	5530	-10.96	-10.20	-10.05	0.15	-5.46	11	PASS
138 (UNII-2c Band)	5690	-5.17	-4.70	-3.82	0.15	0.39	11	PASS
138 (UNII-3 Band)	5690	-6.73	-5.37	-5.78	0.15	-1.00	17	PASS
NOTE:	<p>1. Method a) of power density measurement of KDB 662911 is using for calculating total power density. Total power density is summing entire spectra across corresponding frequency bins on the various outputs by computer.</p> <p>2. The SDM mode is non-correlated mode.</p> <p>3. For Beam forming (MCS0 NSS=3) Mode: 5250~5350MHz: Directional gain = maximum gain of antennas + $10 \log(3/3) = 5.75\text{dBi} < 6\text{dBi}$, so the power density limit shall not be reduced. 5470~5725MHz (Except for UNII-3 Band): Directional gain = maximum gain of antennas + $10 \log(3/3) = 5.75\text{dBi} < 6\text{dBi}$, so the power density limit shall not be reduced. 5725~5825MHz (For UNII-3 Band): Directional gain = maximum gain of antennas + $10 \log(3/3) = 5.71\text{dBi} < 6\text{dBi}$, so the power density limit shall not be reduced.</p> <p>4. Refer to section 3.4 for duty cycle spectrum plot.</p>							



Beam forming (MCS0 NSS=2)_MODE

802.11ac (VHT20)							
CHANNEL	CHANNEL FREQUENCY (MHz)	PSD (dBm)			TOTAL POWER DENSITY (dBm)	MAX. LIMIT (dBm)	PASS/FAIL
		CHAIN 0	CHAIN 1	CHAIN 2			
52	5260	-8.10	-5.73	-8.93	-2.60	9.49	PASS
60	5300	-8.11	-5.64	-10.41	-2.85	9.49	PASS
64	5320	-8.40	-5.14	-10.57	-2.69	9.49	PASS
100	5500	-6.20	-5.45	-4.98	-0.74	9.49	PASS
116	5580	-2.04	-1.82	-1.71	2.92	9.49	PASS
132	5660	-5.21	-4.28	-3.32	0.57	9.49	PASS
140	5700	-5.84	-3.96	-3.56	0.43	9.49	PASS
144 (UNII-2c Band)	5720	2.33	2.69	2.50	7.28	9.49	PASS
144 (UNII-3 Band)	5720	0.92	2.42	1.16	6.32	15.53	PASS
NOTE:	<p>1. Method a) of power density measurement of KDB 662911 is using for calculating total power density. Total power density is summing entire spectra across corresponding frequency bins on the various outputs by computer.</p> <p>2. 5250~5350MHz: Directional gain = maximum gain of antennas + 10 log(3/2) = 7.51dBi > 6dBi , so the power density limit shall be reduced to 11-(7.51-6) = 9.49dBm.</p> <p>5470~5725MHz (Except for UNII-3 Band): Directional gain = maximum gain of antennas + 10 log(3/2) = 7.51dBi > 6dBi , so the power density limit shall be reduced to 11-(7.51-6) = 9.49dBm.</p> <p>5725~5825MHz (For UNII-3 Band): Directional gain = maximum gain of antennas + 10 log(3/2) = 7.47dBi > 6dBi , so the power density limit shall be reduced to 17-(7.47-6) = 15.53dBm.</p>						



802.11ac (VHT40)							
CHANNEL	CHANNEL FREQUENCY (MHz)	PSD (dBm)			TOTAL POWER DENSITY (dBm)	MAX. LIMIT (dBm)	PASS/FAIL
		CHAIN 0	CHAIN 1	CHAIN 2			
54	5270	-6.30	-5.35	-7.18	-1.44	9.49	PASS
62	5310	-7.87	-6.47	-9.61	-3.03	9.49	PASS
102	5510	-6.23	-5.59	-5.40	-0.95	9.49	PASS
110	5550	-4.85	-5.10	-3.96	0.16	9.49	PASS
134	5670	-7.85	-6.61	-5.94	-1.96	9.49	PASS
142 (UNII-2c Band)	5710	-1.63	-0.96	-0.35	3.82	9.49	PASS
142 (UNII-3 Band)	5710	-2.85	-2.12	-1.52	2.64	15.53	PASS
<p>NOTE:</p> <ol style="list-style-type: none"> Method a) of power density measurement of KDB 662911 is using for calculating total power density. Total power density is summing entire spectra across corresponding frequency bins on the various outputs by computer. 5250~5350MHz: Directional gain = maximum gain of antennas + $10 \log(3/2) = 7.51\text{dBi} > 6\text{dBi}$, so the power density limit shall be reduced to $11-(7.51-6) = 9.49\text{dBm}$. 5470~5725MHz (Except for UNII-3 Band): Directional gain = maximum gain of antennas + $10 \log(3/2) = 7.51\text{dBi} > 6\text{dBi}$, so the power density limit shall be reduced to $11-(7.51-6) = 9.49\text{dBm}$. 5725~5825MHz (For UNII-3 Band): Directional gain = maximum gain of antennas + $10 \log(3/2) = 7.47\text{dBi} > 6\text{dBi}$, so the power density limit shall be reduced to $17-(7.47-6) = 15.53\text{dBm}$. 							



802.11ac (VHT80)

CHANNEL	CHANNEL FREQUENCY (MHz)	PSD W/O DUTY FACTOR (dBm)			DUTY FACTOR (dB)	TOTAL PSD WITH DUTY FACTOR (dBm)	MAX. LIMIT (dBm)	PASS/FAIL
		CHAIN 0	CHAIN 1	CHAIN 2				
58	5290	-8.62	-7.97	-9.45	0.15	-3.72	9.49	PASS
106	5530	-10.96	-10.20	-10.05	0.15	-5.46	9.49	PASS
138 (UNII-2c Band)	5690	-5.17	-4.70	-3.82	0.15	0.39	9.49	PASS
138 (UNII-3 Band)	5690	-6.73	-5.37	-5.78	0.15	-1.00	15.53	PASS

NOTE:

- Method a) of power density measurement of KDB 662911 is using for calculating total power density. Total power density is summing entire spectra across corresponding frequency bins on the various outputs by computer.
- 5250~5350MHz:** Directional gain = maximum gain of antennas + $10 \log(3/2) = 7.51\text{dBi} > 6\text{dBi}$, so the power density limit shall be reduced to $11-(7.51-6) = 9.49\text{dBm}$.

5470~5725MHz (Except for UNII-3 Band): Directional gain = maximum gain of antennas + $10 \log(3/2) = 7.51\text{dBi} > 6\text{dBi}$, so the power density limit shall be reduced to $11-(7.51-6) = 9.49\text{dBm}$.

5725~5825MHz (For UNII-3 Band): Directional gain = maximum gain of antennas + $10 \log(3/2) = 7.47\text{dBi} > 6\text{dBi}$, so the power density limit shall be reduced to $17-(7.47-6) = 15.53\text{dBm}$.
- Refer to section 3.4 for duty cycle spectrum plot.



STBC_MODE

802.11ac (VHT20)							
CHANNEL	CHANNEL FREQUENCY (MHz)	PSD (dBm)			TOTAL POWER DENSITY (dBm)	MAX. LIMIT (dBm)	PASS/FAIL
		CHAIN 0	CHAIN 1	CHAIN 2			
52	5260	-8.10	-5.73	-8.93	-2.60	11	PASS
60	5300	-8.11	-5.64	-10.41	-2.85	11	PASS
64	5320	-8.40	-5.14	-10.57	-2.69	11	PASS
100	5500	-4.56	-4.55	-4.90	0.10	11	PASS
116	5580	-2.04	-1.82	-1.71	2.92	11	PASS
132	5660	-5.21	-4.28	-3.32	0.57	11	PASS
140	5700	-4.67	-3.03	-3.36	1.14	11	PASS
144 (UNII-2c Band)	5720	1.78	2.85	3.05	7.37	11	PASS
144 (UNII-3 Band)	5720	1.04	1.71	2.18	6.44	17	PASS
NOTE:	1. Method a) of power density measurement of KDB 662911 is using for calculating total power density. Total power density is summing entire spectra across corresponding frequency bins on the various outputs by computer.						

802.11ac (VHT40)							
CHANNEL	CHANNEL FREQUENCY (MHz)	PSD (dBm)			TOTAL POWER DENSITY (dBm)	MAX. LIMIT (dBm)	PASS/FAIL
		CHAIN 0	CHAIN 1	CHAIN 2			
54	5270	-6.30	-5.35	-7.18	-1.44	11	PASS
62	5310	-7.87	-6.47	-9.61	-3.03	11	PASS
102	5510	-4.19	-4.98	-4.95	0.08	11	PASS
110	5550	-3.12	-4.07	-4.18	1.01	11	PASS
134	5670	-5.14	-4.62	-4.89	-0.11	11	PASS
142 (UNII-2c Band)	5710	0.28	1.17	1.50	5.78	11	PASS
142 (UNII-3 Band)	5710	-1.79	0.60	0.09	4.52	17	PASS
NOTE:	1. Method a) of power density measurement of KDB 662911 is using for calculating total power density. Total power density is summing entire spectra across corresponding frequency bins on the various outputs by computer.						



802.11ac (VHT80)

CHANNEL	CHANNEL FREQUENCY (MHz)	PSD W/O DUTY FACTOR (dBm)			DUTY FACTOR (dB)	TOTAL PSD WITH DUTY FACTOR (dBm)	MAX. LIMIT (dBm)	PASS/FAIL
		CHAIN 0	CHAIN 1	CHAIN 2				
58	5290	-8.62	-7.97	-9.45	0.15	-3.72	11	PASS
106	5530	-10.96	-10.20	-10.05	0.15	-5.46	11	PASS
138 (UNII-2c Band)	5690	-3.04	-2.68	-1.91	0.15	2.40	11	PASS
138 (UNII-3 Band)	5690	-4.06	-4.20	-3.45	0.15	1.03	17	PASS

NOTE: 1. Method a) of power density measurement of KDB 662911 is using for calculating total power density. Total power density is summing entire spectra across corresponding frequency bins on the various outputs by computer.
2. Refer to section 3.4 for duty cycle spectrum plot.



A D T

SPECTRUM PLOT OF WORST VALUE

STBC_MODE <802.11ac (VHT20)_Chain (2) / CH144 (UNII-2c Band)>

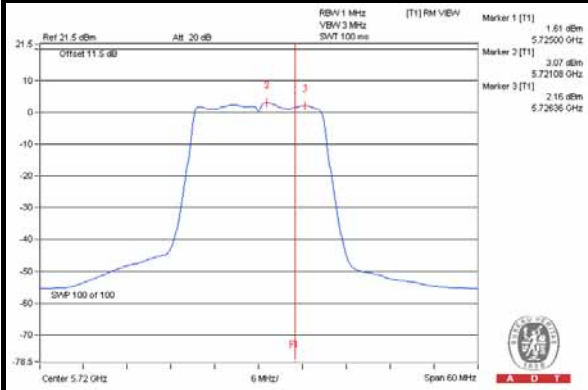

STBC_MODE <802.11ac (VHT40)_Chain (2) / CH142 (UNII-2c Band)>

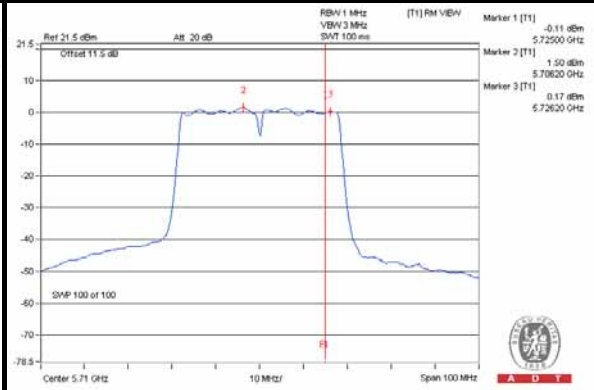

STBC_MODE <802.11ac (VHT80)_Chain (2) / CH138 (UNII-2c Band)>

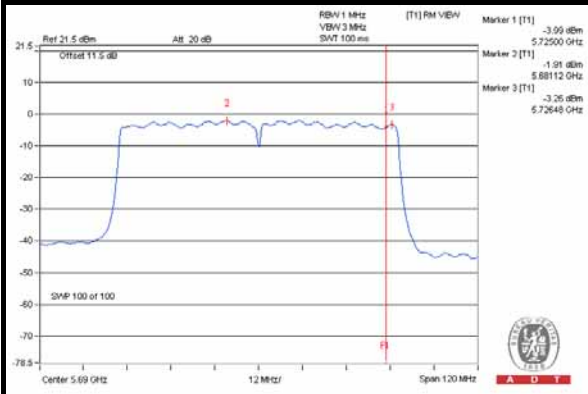



4.4.8 TEST RESULTS (MODE 2)

CDD, Beam forming (MCS0 NSS=1)_MODE

802.11ac (VHT20)						
CHANNEL	CHANNEL FREQUENCY (MHz)	PSD (dBm)		TOTAL POWER DENSITY (dBm)	MAX. LIMIT (dBm)	PASS / FAIL
		CHAIN 0	CHAIN 1			
52	5260	-4.82	-3.49	-1.09	9.13	PASS
60	5300	-4.89	-3.40	-1.07	9.13	PASS
64	5320	-4.66	-3.36	-0.95	9.13	PASS
100	5500	-2.47	-1.82	0.88	9.05	PASS
116	5580	0.65	1.15	3.92	9.05	PASS
132	5660	0.05	0.55	3.32	9.05	PASS
140	5700	-0.35	0.07	2.88	9.05	PASS
144 (UNII-2c Band)	5720	2.64	4.28	6.55	9.05	PASS
144 (UNII-3 Band)	5720	1.59	3.32	5.55	15.07	PASS
NOTE:	<p>1. Method a) of power density measurement of KDB 662911 is using for calculating total power density. Total power density is summing entire spectra across corresponding frequency bins on the various outputs by computer.</p> <p>2. 5250~5350MHz: Directional gain = $10 \log[(10^{G1/20} + 10^{G2/20})^2 / 2] = 7.87\text{dBi} > 6\text{dBi}$, so the power density limit shall be reduced to $11-(7.87-6) = 9.13\text{dBm}$.</p> <p>5470~5725MHz (Except for UNII-3 Band): Directional gain = $10 \log[(10^{G1/20} + 10^{G2/20})^2 / 2] = 7.95\text{dBi} > 6\text{dBi}$, so the power density limit shall be reduced to $11-(7.95-6) = 9.05\text{dBm}$.</p> <p>5725~5825MHz (For UNII-3 Band): Directional gain = $10 \log[(10^{G1/20} + 10^{G2/20})^2 / 2] = 7.93\text{dBi} > 6\text{dBi}$, so the power density limit shall be reduced to $17-(7.93-6) = 15.07\text{dBm}$.</p>					



A D T

802.11ac (VHT40)

CHANNEL	CHANNEL FREQUENCY (MHz)	PSD (dBm)		TOTAL POWER DENSITY (dBm)	MAX. LIMIT (dBm)	PASS / FAIL
		CHAIN 0	CHAIN 1			
54	5270	-3.81	-3.29	-0.37	9.13	PASS
62	5310	-4.05	-3.31	-0.49	9.13	PASS
102	5510	-4.58	-4.08	-1.15	9.05	PASS
110	5550	-2.94	-1.94	0.76	9.05	PASS
134	5670	-1.67	-1.42	1.63	9.05	PASS
142 (UNII-2c Band)	5710	1.53	3.27	5.66	9.05	PASS
142 (UNII-3 Band)	5710	0.47	2.16	4.57	15.07	PASS
NOTE:	1. Method a) of power density measurement of KDB 662911 is using for calculating total power density. Total power density is summing entire spectra across corresponding frequency bins on the various outputs by computer. 2. 5250~5350MHz: Directional gain = $10 \log[(10^{G1/20} + 10^{G2/20})^2 / 2] = 7.87\text{dBi} > 6\text{dBi}$, so the power density limit shall be reduced to $11-(7.87-6) = 9.13\text{dBm}$. 5470~5725MHz (Except for UNII-3 Band): Directional gain = $10 \log[(10^{G1/20} + 10^{G2/20})^2 / 2] = 7.95\text{dBi} > 6\text{dBi}$, so the power density limit shall be reduced to $11-(7.95-6) = 9.05\text{dBm}$. 5725~5825MHz (For UNII-3 Band): Directional gain = $10 \log[(10^{G1/20} + 10^{G2/20})^2 / 2] = 7.93\text{dBi} > 6\text{dBi}$, so the power density limit shall be reduced to $17-(7.93-6) = 15.07\text{dBm}$.					



A D T

802.11ac (VHT80)

CHANNEL	CHANNEL FREQUENCY (MHz)	PSD W/O DUTY FACTOR (dBm)		DUTY FACTOR (dB)	TOTAL PSD WITH DUTY FACTOR (dBm)	MAX. LIMIT (dBm)	PASS/FAIL
		CHAIN 0	CHAIN 1				
58	5290	-6.13	-5.32	0.3	-2.40	9.13	PASS
106	5530	-8.49	-7.78	0.3	-4.81	9.05	PASS
138 (UNII-2c Band)	5690	-1.27	0.25	0.3	2.87	9.05	PASS
138 (UNII-3 Band)	5690	-2.78	-1.10	0.3	1.45	15.07	PASS

- NOTE:**
- Method a) of power density measurement of KDB 662911 is using for calculating total power density. Total power density is summing entire spectra across corresponding frequency bins on the various outputs by computer.
 - 5250~5350MHz:** Directional gain = $10 \log[(10^{G1/20} + 10^{G2/20})^2 / 2] = 7.87\text{dBi} > 6\text{dBi}$, so the power density limit shall be reduced to $11-(7.87-6) = 9.13\text{dBm}$.

5470~5725MHz (Except for UNII-3 Band): Directional gain = $10 \log[(10^{G1/20} + 10^{G2/20})^2 / 2] = 7.95\text{dBi} > 6\text{dBi}$, so the power density limit shall be reduced to $11-(7.95-6) = 9.05\text{dBm}$.

5725~5825MHz (For UNII-3 Band): Directional gain = $10 \log[(10^{G1/20} + 10^{G2/20})^2 / 2] = 7.93\text{dBi} > 6\text{dBi}$, so the power density limit shall be reduced to $17-(7.93-6) = 15.07\text{dBm}$.
 - Refer to section 3.4 for duty cycle spectrum plot.



SDM, Beam forming (MCS0 NSS=2)_MODE

802.11ac (VHT20)						
CHANNEL	CHANNEL FREQUENCY (MHz)	PSD (dBm)		TOTAL POWER DENSITY (dBm)	MAX. LIMIT (dBm)	PASS / FAIL
		CHAIN 0	CHAIN 1			
52	5260	-4.82	-3.49	-1.09	11	PASS
60	5300	-4.89	-3.40	-1.07	11	PASS
64	5320	-4.66	-3.36	-0.95	11	PASS
100	5500	-2.47	-1.82	0.88	11	PASS
116	5580	0.65	1.15	3.92	11	PASS
132	5660	0.05	0.55	3.32	11	PASS
140	5700	-0.35	0.07	2.88	11	PASS
144 (UNII-2c Band)	5720	2.64	4.28	6.55	11	PASS
144 (UNII-3 Band)	5720	1.59	3.32	5.55	17	PASS
NOTE:	1. Method a) of power density measurement of KDB 662911 is using for calculating total power density. Total power density is summing entire spectra across corresponding frequency bins on the various outputs by computer.					

802.11ac (VHT40)						
CHANNEL	CHANNEL FREQUENCY (MHz)	PSD (dBm)		TOTAL POWER DENSITY (dBm)	MAX. LIMIT (dBm)	PASS / FAIL
		CHAIN 0	CHAIN 1			
54	5270	-3.81	-3.29	-0.37	11	PASS
62	5310	-4.05	-3.31	-0.49	11	PASS
102	5510	-4.58	-4.08	-1.15	11	PASS
110	5550	-2.94	-1.94	0.76	11	PASS
134	5670	-1.67	-1.42	1.63	11	PASS
142 (UNII-2c Band)	5710	1.53	3.27	5.66	11	PASS
142 (UNII-3 Band)	5710	0.47	2.16	4.57	17	PASS
NOTE:	1. Method a) of power density measurement of KDB 662911 is using for calculating total power density. Total power density is summing entire spectra across corresponding frequency bins on the various outputs by computer.					



802.11ac (VHT80)

CHANNEL	CHANNEL FREQUENCY (MHz)	PSD W/O DUTY FACTOR (dBm)		DUTY FACTOR (dB)	TOTAL PSD WITH DUTY FACTOR (dBm)	MAX. LIMIT (dBm)	PASS/FAIL
		CHAIN 0	CHAIN 1				
58	5290	-6.13	-5.32	0.16	-2.40	11	PASS
106	5530	-8.49	-7.78	0.16	-4.81	11	PASS
138 (UNII-2c Band)	5690	-1.27	0.25	0.16	2.87	11	PASS
138 (UNII-3 Band)	5690	-2.78	-1.10	0.16	1.45	17	PASS

NOTE: 1. Method a) of power density measurement of KDB 662911 is using for calculating total power density. Total power density is summing entire spectra across corresponding frequency bins on the various outputs by computer.
2. Refer to section 3.4 for duty cycle spectrum plot.



STBC_MODE

802.11ac (VHT20)						
CHANNEL	CHANNEL FREQUENCY (MHz)	PSD (dBm)		TOTAL POWER DENSITY (dBm)	MAX. LIMIT (dBm)	PASS / FAIL
		CHAIN 0	CHAIN 1			
52	5260	-4.18	-2.71	-0.37	11	PASS
60	5300	-4.16	-3.16	-0.62	11	PASS
64	5320	-4.19	-3.09	-0.59	11	PASS
100	5500	-2.09	-1.88	1.03	11	PASS
116	5580	1.10	1.51	4.32	11	PASS
132	5660	0.51	0.88	3.71	11	PASS
140	5700	0.26	0.47	3.38	11	PASS
144 (UNII-2c Band)	5720	2.64	4.28	6.55	11	PASS
144 (UNII-3 Band)	5720	1.59	3.32	5.55	17	PASS
NOTE:	1. Method a) of power density measurement of KDB 662911 is using for calculating total power density. Total power density is summing entire spectra across corresponding frequency bins on the various outputs by computer.					

802.11ac (VHT40)						
CHANNEL	CHANNEL FREQUENCY (MHz)	PSD (dBm)		TOTAL POWER DENSITY (dBm)	MAX. LIMIT (dBm)	PASS / FAIL
		CHAIN 0	CHAIN 1			
54	5270	-3.52	-2.81	0.02	11	PASS
62	5310	-4.05	-3.31	-0.49	11	PASS
102	5510	-4.27	-3.86	-0.89	11	PASS
110	5550	-2.30	-1.78	1.14	11	PASS
134	5670	-1.67	-1.42	1.63	11	PASS
142 (UNII-2c Band)	5710	2.07	3.90	6.25	11	PASS
142 (UNII-3 Band)	5710	1.10	3.00	5.32	17	PASS
NOTE:	1. Method a) of power density measurement of KDB 662911 is using for calculating total power density. Total power density is summing entire spectra across corresponding frequency bins on the various outputs by computer.					

802.11ac (VHT80)

CHANNEL	CHANNEL FREQUENCY (MHz)	PSD W/O DUTY FACTOR (dBm)		DUTY FACTOR (dB)	TOTAL PSD WITH DUTY FACTOR (dBm)	MAX. LIMIT (dBm)	PASS/FAIL
		CHAIN 0	CHAIN 1				
58	5290	-4.41	-3.82	0.3	-0.79	11	PASS
106	5530	-8.49	-7.78	0.3	-4.81	11	PASS
138 (UNII-2c Band)	5690	-1.27	0.25	0.3	2.87	11	PASS
138 (UNII-3 Band)	5690	-2.78	-1.10	0.3	1.45	17	PASS

NOTE: 1. Method a) of power density measurement of KDB 662911 is using for calculating total power density. Total power density is summing entire spectra across corresponding frequency bins on the various outputs by computer.
 2. Refer to section 3.4 for duty cycle spectrum plot.

SPECTRUM PLOT OF WORST VALUE

STBC_MODE <802.11ac (VHT20)_Chain (1) / CH144 (UNII-2c Band)>

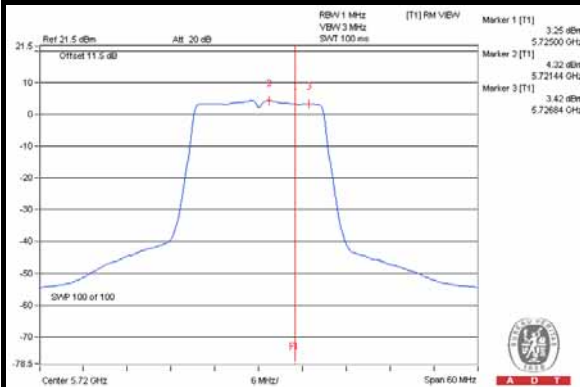

STBC_MODE <802.11ac (VHT40)_Chain (1) / CH142 (UNII-2c Band)>

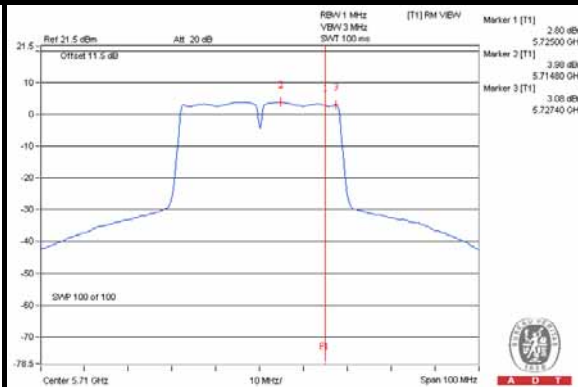

STBC_MODE <802.11ac (VHT80)_Chain (1) / CH138 (UNII-2c Band)>

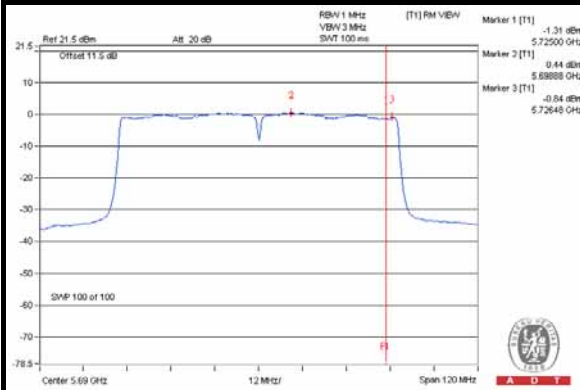



A D T

4.4.9 TEST RESULTS (MODE 3)

802.11a				
CHANNEL	FREQUENCY (MHz)	PSD (dBm)	MAXIMUM LIMIT (dBm)	PASS/FAIL
52	5260	-4.43	11	PASS
60	5300	-6.04	11	PASS
64	5320	-5.98	11	PASS
100	5500	-2.45	11	PASS
116	5580	-1.80	11	PASS
132	5660	-3.71	11	PASS
140	5700	-4.77	11	PASS
144 (UNII-2c Band)	5720	1.13	11	PASS
144 (UNII-3 Band)	5720	0.25	17	PASS

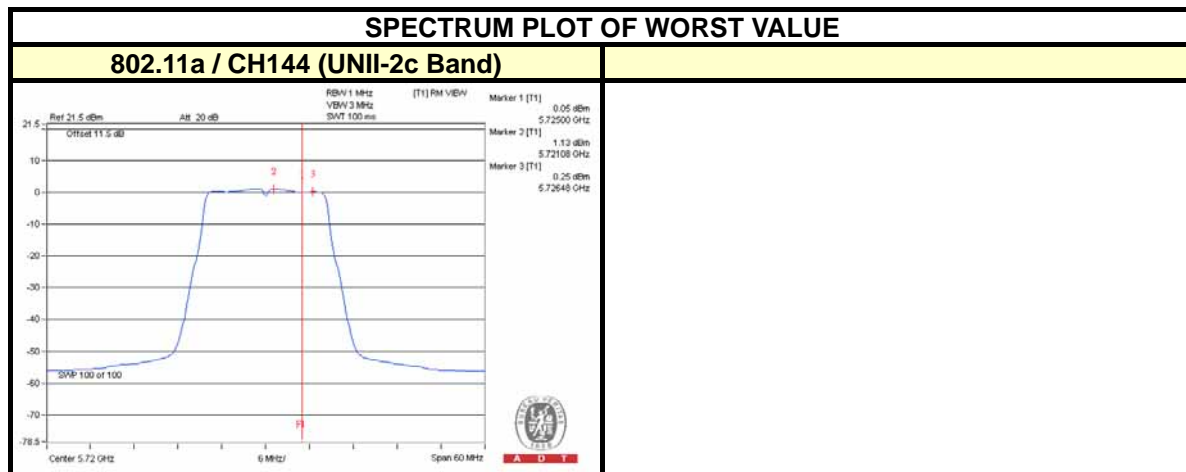

4.5 PEAK POWER EXCURSION MEASUREMENT

4.5.1 LIMITS OF PEAK POWER EXCURSION MEASUREMENT

Shall not exceed 13 dB

4.5.2 TEST INSTRUMENTS

DESCRIPTION & MANUFACTURER	MODEL NO.	SERIAL NO.	CALIBRATED DATE	CALIBRATED UNTIL
SPECTRUM ANALYZER R&S	FSV 40	100964	July 15, 2013	July 14, 2014

Note:

1. The calibration interval of the above test instruments is 12 months and the calibrations are traceable to NML/ROC and NIST/USA.
2. Tested date : May 05, 2014

4.5.3 TEST PROCEDURE

1. Set RBW = 1 MHz, VBW \geq 3 MHz, Detector = peak.
2. Trace mode = max-hold. Allow the sweeps to continue until the trace stabilizes.
3. Use the peak search function to find the peak of the spectrum.
4. Measure the PPSD.
5. Compute the ratio of the maximum of the peak-max-hold spectrum to the PPSD.

4.5.4 DEVIATION FROM TEST STANDARD

No deviation

4.5.5 TEST SETUP

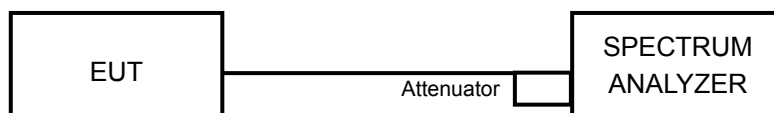

4.5.6 EUT OPERATING CONDITIONS

The software provided by client to enable the EUT under transmission condition continuously at specific channel frequencies individually.



4.5.7 TEST RESULTS (MODE 1)

MODULATION MODE	MODULATION TYPE	CHANNEL FREQUENCY (MHz)	PEAK VALUE (dBm)	PPSD (dBm)	PEAK EXCURSION (dB)	LIMIT (dB)	PASS/ FAIL
802.11ac (VHT20)	BPSK	5700	2.86	-5.78	8.64	13	PASS
802.11ac (VHT40)	BPSK	5700	1.58	-7.83	9.41	13	PASS

MODULATION MODE	MODULATION TYPE	CHAN. FREQ. (MHz)	PEAK VALUE (dBm)	PPSD WITHOUT DUTY FACTOR (dBm)	PPSD WITH DUTY FACTOR (dBm)	PEAK EXCURSION (dB)	LIMIT (dB)	PASS /FAIL
802.11ac (VHT20)	QPSK	5700	3.85	-5.04	-4.92	8.77	13	PASS
	16QAM		4.62	-5	-4.86	9.48	13	PASS
	64QAM		5.16	-5.1	-4.87	10.03	13	PASS
	256QAM		5.23	-5.03	-4.71	9.94	13	PASS
802.11ac (VHT40)	QPSK	5670	2.54	-6.7	-6.57	9.11	13	PASS
	16QAM		2.95	-6.92	-6.69	9.64	13	PASS
	64QAM		3.14	-6.77	-6.32	9.46	13	PASS
	256QAM		2.7	-6.86	-6.23	8.93	13	PASS
802.11ac (VHT80)	BPSK	5530	-1.37	-10.92	-10.77	9.4	13	PASS
	QPSK		-0.2	-10.48	-10.23	10.03	13	PASS
	16QAM		0.86	-10.34	-9.94	10.8	13	PASS
	64QAM		-0.35	-10.39	-9.79	9.44	13	PASS
	256QAM		-0.07	-10.52	-9.77	9.7	13	PASS

NOTE: 1. Refer to section 3.4 for duty cycle spectrum plot.



A D T

SPECTRUM PLOT OF WORST VALUE

802.11ac (VHT20) / 64QAM

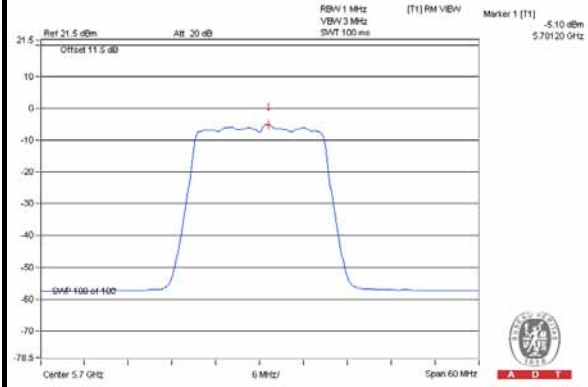
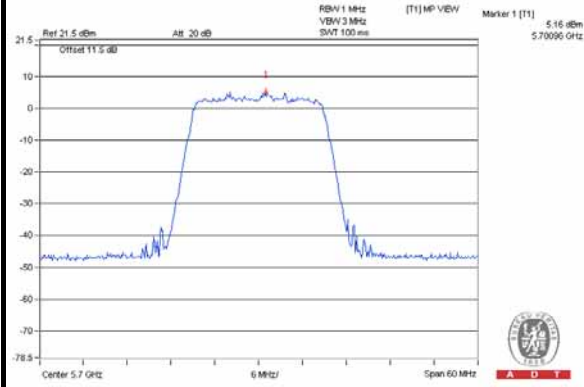

802.11ac (VHT40) / 16QAM

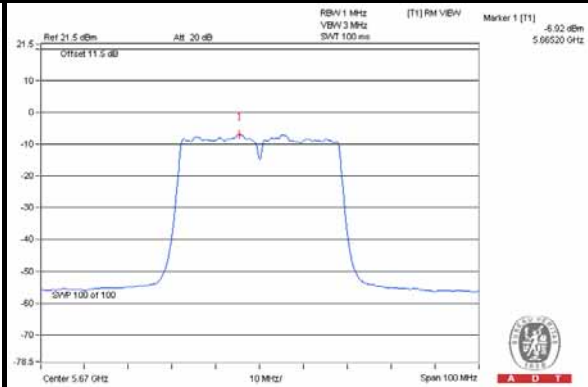
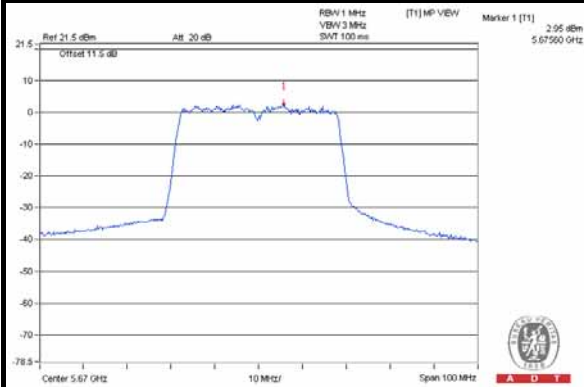

802.11ac (VHT80) / 16QAM

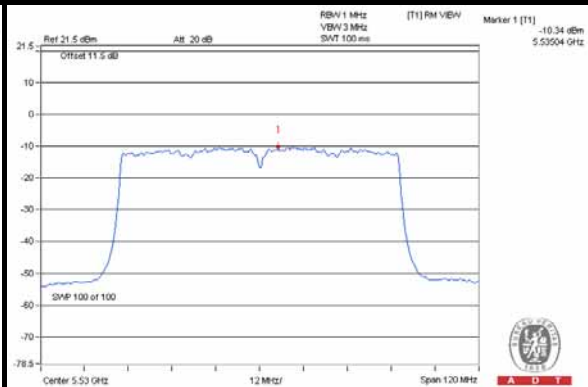
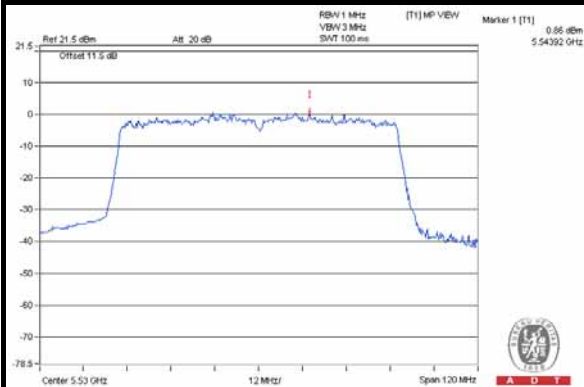



A D T

4.5.8 TEST RESULTS (MODE 3)

MODULATION MODE	MODULATION TYPE	CHANNEL FREQUENCY (MHz)	PEAK VALUE (dBm)	PPSD (dBm)	PEAK EXCURSION (dB)	LIMIT (dB)	PASS/ FAIL
802.11a	BPSK	5700	3.43	-4.77	8.2	13	PASS
	QPSK		4.29	-3.71	8	13	PASS

MODULATION MODE	MODULATION TYPE	CHAN. FREQ. (MHz)	PEAK VALUE (dBm)	PPSD WITHOUT DUTY FACTOR (dBm)	PPSD WITH DUTY FACTOR (dBm)	PEAK EXCURSION (dB)	LIMIT (dB)	PASS /FAIL
802.11a	16QAM	5700	5.04	-3.82	-3.69	8.73	13	PASS
	64QAM		4.89	-3.71	-3.48	8.37	13	PASS

NOTE: 1. Refer to section 3.4 for duty cycle spectrum plot.

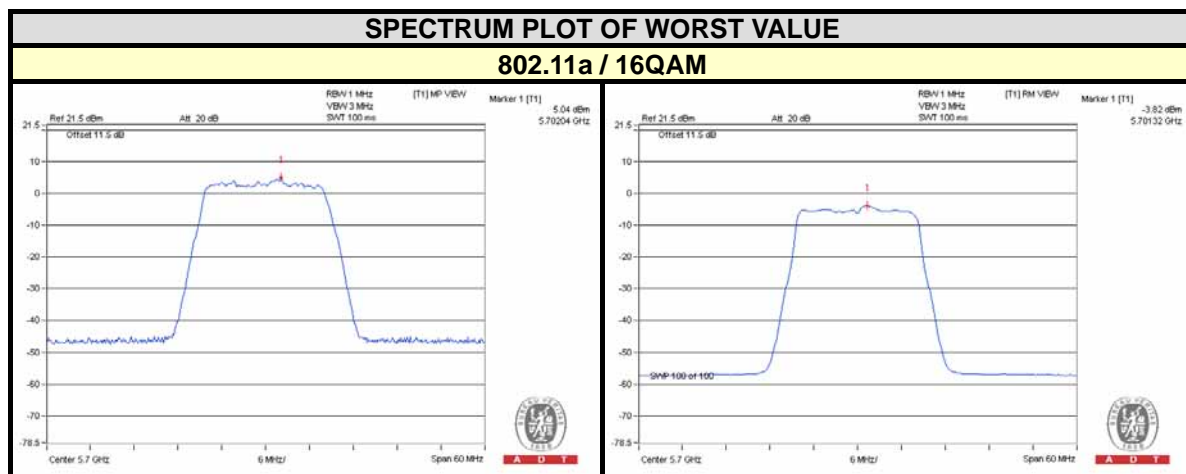



A D T

4.6 FREQUENCY STABILITY

4.6.1 LIMITS OF FREQUENCY STABILITY MEASUREMENT

The frequency of the carrier signal shall be maintained within band of operation

4.6.2 TEST INSTRUMENTS

DESCRIPTION & MANUFACTURER	MODEL NO.	SERIAL NO.	CALIBRATED DATE	CALIBRATED UNTIL
Spectrum Analyzer R&S	FSV 40	100964	July 15, 2013	July 14, 2014
Temperature & Humidity Chamber GIANTFORCE	GTH-150-40 -SP-AR	MAA0812-008	Jan. 13, 2014	Jan. 12, 2015

Note:

1. The calibration interval of the above test instruments is 12 months and the calibrations are traceable to NML/ROC and NIST/USA.
2. Tested date : May 05, 2014

4.6.3 TEST PROCEDURE

1. The EUT was placed inside the environmental test chamber and powered by nominal AC voltage.
2. Turn the EUT on and couple its output to a spectrum analyzer.
3. Turn the EUT off and set the chamber to the highest temperature specified.
4. Allow sufficient time (approximately 30 min) for the temperature of the chamber to stabilize, turn the EUT on and measure the operating frequency after 2, 5, and 10 minutes.
5. Repeat step 2 and 3 with the temperature chamber set to the lowest temperature.
6. The test chamber was allowed to stabilize at +20 degree C for a minimum of 30 minutes. The supply voltage was then adjusted on the EUT from 85% to 115% and the frequency record.

4.6.4 DEVIATION FROM TEST STANDARD

No deviation

4.6.5 TEST SETUP

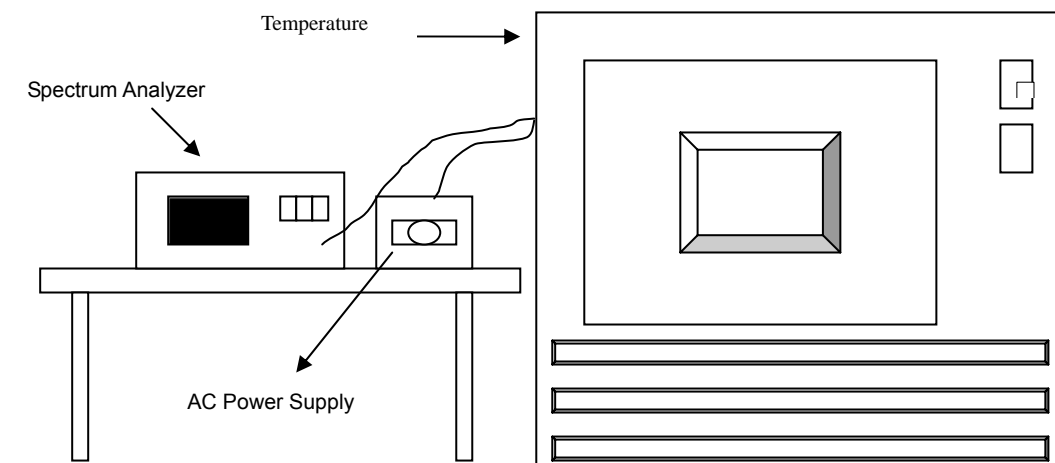

4.6.6 EUT OPERATING CONDITION

Set the EUT transmit at un-modulation mode to test frequency stability.



A D T

4.6.7 TEST RESULTS

FREQUENCY STABILITY VERSUS TEMP.									
OPERATING FREQUENCY: 5320MHz									
TEMP. (°C)	POWER SUPPLY (Vac)	0 MINUTE		2 MINUTE		5 MINUTE		10 MINUTE	
		Measured Frequency	Frequency Drift	Measured Frequency	Frequency Drift	Measured Frequency	Frequency Drift	Measured Frequency	Frequency Drift
		(MHz)	%	(MHz)	%	(MHz)	%	(MHz)	%
50	120	5320.0192	0.00036	5320.0146	0.00027	5320.017	0.00032	5320.0157	0.00030
40	120	5320.0017	0.00003	5319.9994	-0.00001	5320.0024	0.00005	5320.0043	0.00008
30	120	5320.0234	0.00044	5320.0233	0.00044	5320.0251	0.00047	5320.0216	0.00041
20	120	5319.9956	-0.00008	5319.9998	0.00000	5320	0.00000	5319.9999	0.00000
10	120	5319.9984	-0.00003	5319.9988	-0.00002	5319.9944	-0.00011	5319.9995	-0.00001
0	120	5320.0039	0.00007	5320.0038	0.00007	5320.0023	0.00004	5320.0009	0.00002
-10	120	5319.9959	-0.00008	5319.9912	-0.00017	5319.9929	-0.00013	5319.9936	-0.00012
-20	120	5319.984	-0.00030	5319.9822	-0.00033	5319.9828	-0.00032	5319.9815	-0.00035
-30	120	5319.9866	-0.00025	5319.9888	-0.00021	5319.9894	-0.00020	5319.9853	-0.00028

FREQUENCY STABILITY VERSUS VOLTAGE									
OPERATING FREQUENCY: 5320MHz									
TEMP. (°C)	POWER SUPPLY (Vac)	0 MINUTE		2 MINUTE		5 MINUTE		10 MINUTE	
		Measured Frequency	Frequency Drift	Measured Frequency	Frequency Drift	Measured Frequency	Frequency Drift	Measured Frequency	Frequency Drift
		(MHz)	%	(MHz)	%	(MHz)	%	(MHz)	%
20	138	5319.9957	-0.00008	5319.9998	0.00000	5320.0009	0.00002	5320.0003	0.00001
	120	5319.9956	-0.00008	5319.9998	0.00000	5320	0.00000	5319.9999	0.00000
	102	5319.9955	-0.00008	5320.0007	0.00001	5319.9999	0.00000	5319.999	-0.00002



A D T

5. PHOTOGRAPHS OF THE TEST CONFIGURATION

Please refer to the attached file (Test Setup Photo).



A D T

6. INFORMATION ON THE TESTING LABORATORIES

We, Bureau Veritas Consumer Products Services (H.K.) Ltd., Taoyuan Branch, were founded in 1988 to provide our best service in EMC, Radio, Telecom and Safety consultation. Our laboratories are accredited and approved according to ISO/IEC 17025.

If you have any comments, please feel free to contact us at the following:

Linko EMC/RF Lab:

Tel: 886-2-26052180

Fax: 886-2-26052943

Hsin Chu EMC/RF Lab:

Tel: 886-3-5935343

Fax: 886-3-5935342

Hwa Ya EMC/RF/Safety/Telecom Lab:

Tel: 886-3-3183232

Fax: 886-3-3270892

Email: service.adt@tw.bureauveritas.com

Web Site: www.bureauveritas-adt.com

The address and road map of all our labs can be found in our web site also.



A D T

7. APPENDIX A - MODIFICATIONS RECORDERS FOR ENGINEERING CHANGES TO THE EUT BY THE LAB

No modifications were made to the EUT by the lab during the test.

--- END ---