

Instruction Manual

Automatic Upper Arm Blood Pressure Monitor



Model No. HL868AX

Table of Contents

Medical Disclaimer	3
Intended Use	3
About Blood Pressure	4
Measurement Method	6
Accuracy	7
Precautions	8
Device Overview	10
Symbol Definitions	12
Features.....	14
Installing Batteries	18
Using the AC/DC Adapter	19
Applying the Cuff	20
Measurement Procedure.....	21
Memory Function	25
Storage and Maintenance	28
Troubleshooting	30
Limited Warranty.....	32
Specifications	33
Note	34
Appendix.....	36
Blood Pressure Diary	39

Medical Disclaimer

This manual and product are not meant as a substitute for advice provided by your doctor.

You are not to use the information contained herein, or this product for diagnosing or treating a health problem or prescribing any medication. If you have or suspect that you have a medical problem, promptly consult your healthcare provider.

Intended Use

This device uses the oscillometric method to automatically measure systolic and diastolic blood pressure as well as heart rate. All values can be read out on one LCD panel. Measurement position is at human being's upper arm. The intended use of this over-the-counter device is for adults aged 18 years and older with arm circumference ranging from 9 inches to 17 inches (approx.23 cm to 43 cm) and for home use.

HL868AX detects the appearance of irregular heartbeats during measurement; an indicated symbol will appear with measuring reading. And the Risk Category Indicator will show the information with the readings on the screen for the user tracking their blood pressure level.

The device can accurately measure blood pressure in pregnant patients including those with known or suspected in pre-eclampsia condition.

Besides, the device features a built-in "Bluetooth Data Transmission" function, which enables the device automatically transmits measuring results to paired Bluetooth-enabled device. Also, users could simply synchronize the current date and time, and check the battery status of blood pressure monitor by means of DailyChek® application software with the paired Bluetooth-enabled device.

About Blood Pressure

1. What is blood pressure?

Blood pressure is the measurement of the force of blood pushing against the walls of the arteries. Arterial blood pressure is constantly fluctuating during the course of the cardiac cycle. The highest pressure in the cycle is called the systolic blood pressure, and represents the pressure in the artery when the heart is beating. The lowest pressure is the diastolic blood pressure, and represents the pressure in the artery when the heart is at rest. Both the systolic and the diastolic pressure are necessary for a physician to evaluate the status of a patient's blood pressure.

Many factors such as physical activity, anxiety or the time of day, can influence your blood pressure. Blood pressure is typically low in the mornings and increases from the afternoon to the evening. It is on average lower in the summer and higher in the winter.

2. Why is it useful to measure blood pressure at home?

Having one's blood pressure measured by a doctor in a hospital or a clinic is often associated with an event called "White Coat Hypertension" where the patient becomes nervous or anxious, thus raising his blood pressure. There are also numerous other factors that might cause your blood pressure to be raised at a specific time of day. This is why medical physician recommend home monitoring as it is important to get readings of blood pressure during different times of the day to really get an idea of your real blood pressure.

Medical physicians generally recommend the "Rule of 3", where you are encouraged to take your blood pressure three times in a row (at 3 ~ 5 minute interval), three times a day for three days. After three days you can average all the results and this will give you an accurate idea of what your blood pressure really is.

About Blood Pressure

A. AHA blood pressure classifications:

Standards for assessment of high or low blood pressure without regard to age, have been established by the American Heart Association (AHA 2017), as shown in the chart.

BLOOD PRESSURE CATEGORY	SYSTOLIC mm Hg (upper number)		DIASTOLIC mmHg (lower number)
NORMAL	LESS THAN 120	and	LESS THAN 80
ELEVATED	120-129	and	LESS THAN 80
HIGH BLOOD PRESSURE (HYPERTENSION) STAGE 1	130-139	or	80-89
HIGH BLOOD PRESSURE (HYPERTENSION) STAGE 2	140 OR HIGHER	or	90 OR HIGHER
HYPERTENSIVE CRISIS (consult your doctor immediately)	HIGNER THAN 180	And/or	HIGHER THAN 120

However, this chart is not exact for classification of blood pressure and it's intended to be used as a guide in understanding non-invasive blood pressure measurements. Please consult with your physician for proper diagnosis.

B. Variations in blood pressure:

Individual blood pressures vary greatly both on a daily and a seasonal basis. These variations are even more pronounced in hypertensive patients. Normally the blood pressure rises while at work and is at its lowest during sleeping period.

(hypertension: means a person who has high blood pressure symptom.)

The graph below illustrates the variations in blood pressure over a whole day with measurement taken every five minutes.

The thick line represents sleep. The rise in blood pressure at 4 PM (A in the graph) and 12 AM (B in the graph) correspond to an attack of pain.

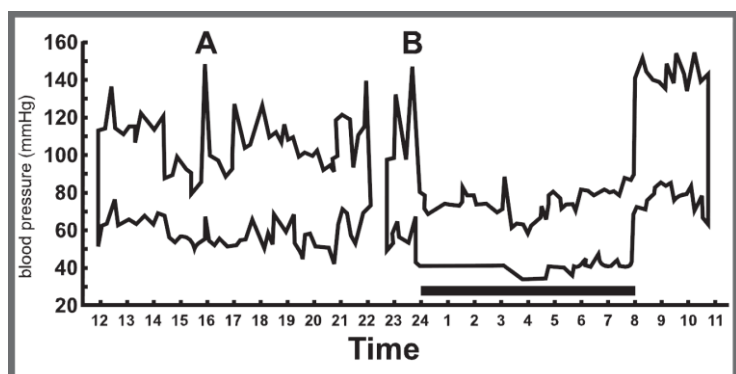

(Direct arterial pressure recording in unrestricted man. Beven, Honour & Stott: Clin. Sci. 36:329. 1969)

Measurement Method

HL868AX Automatic Upper Arm Blood Pressure Monitor measures blood pressure and heart rate by oscillometric method, meaning the fluctuations in pressure are measured. Once the cuff is wrapped around your upper arm, just turn on the monitor and inflation automatically starts. The inflation of the cuff creates pressure around the arteries inside upper arm.

Within the cuff is a gauge which senses the fluctuations (oscillations) in pressure. The fluctuation measured represents the degree of intensity that your arteries contracting with each heartbeat, and also a result of the pressure that the cuff has placed on the upper arm. The monitor measures these contractions and converts the information to a digital value. This is the result displayed on the monitor screen.

Once the measurement is completed, the cuff will automatically deflate.

Accuracy

HL868AX Automatic Upper Arm Blood Pressure Monitor has been clinically tested against a scientific device called *mercury sphygmomanometer*, considered the gold standard in blood pressure measurement.

All HL868AX Automatic Upper Arm Blood Pressure Monitors have performed equivalent to measurements taken with this scientific device and are within the accuracy limits prescribed by the American National Standard for Electronic or Automated Sphygmomanometers.

The SPHYGMOMANOMETER was clinically investigated according to the requirements of ISO 81060-2:2013.

In case it is needed to have the device checked for calibration, please consult the distributor. This is recommended to be considered every two years.

Precautions

- * Read the Instruction Manual thoroughly before measuring and keep it at hand for your reference at any time.
 - * The device is designed for home use and not suitable for clinical use.
 - * The patient is an intended operator, who can operate the device by himself or herself, not necessarily by a physician or operator.
 - * This monitor is not intended for use in the MR environment.
- Do not take a measurement in a too low (less than 41°F/5°C) or too high (more than 104°F/40°C) temperature, nor in a place outside humidity ranges (15 % ~ 93 % R.H.) and atmospheric pressure ranges (700 ~ 1060 hPa), or you may get inaccurate readings.
 - Wait 30 ~ 45 minutes before measurement if you've just consumed caffeinated beverages or smoked cigarettes.
 - Please rest for at least 5 ~ 10 minutes before taking a measurement.
 - To allow your blood vessels to return to the condition prior to taking the measurement, please wait at least 3 ~ 5 minutes between measurements. You may need to adjust the wait time according to your personal physiological situation.
 - We recommend you using the same arm (preferably the left arm) and measuring around the same time each day.
 - Perform measurements in a quiet and relaxed environment at room temperature.
 - Do not move or shake the device during a measurement. Please keep quiet and do not talk during measurements.
 - If you are pregnant, you should pay more attention to your blood pressure changes, because during this time, it may change drastically.
 - This monitor is clinically validated for use in pregnancy and pre-eclampsia. When you detect unusual readings in pregnancy, you should measure again after taking some rest. If the reading is still abnormal, consult your doctor or gynecologist.
 - This product is not suitable for:
 - People with arrhythmias
 - Undergoing intravenous injection on any limb
 - Currently in a dialysis treatment
 - In pre-eclampsia condition
 - The applied part is the cuff.

Precautions

- ❑ For those who have had a mastectomy or lymph node clearance, it is recommended to take a measurement on the unaffected side.
- ❑ When used among medical electronic equipments on the same limb, pressurization of the cuff may cause temporarily malfunction to other devices.
- ❑ If you have one of the circulatory problems **such** as arteriosclerosis, diabetes, liver disease, kidney disease, severe hypertension, peripheral circulation....., please consult your healthcare professional before using the device.
- ❑ Blood pressure measurements determined with this device are equivalent to those obtained by a trained observer using the cuff/stethoscope auscultation method and are within the accuracy limits prescribed by the American National Standard for Manual, electronic, or Automated Sphygmomanometers.
- ❑ Results are not intended for direct diagnosis. Please consult with a physician if you have any questions or concerns about your results.

***Attention !**

1. Do not use the device on infants, children, or those who cannot express their own intention. To avoid accidental strangulation, keep this product away from children and do not drape tube around neck.
2. The medical device should not **be** used adjacent to or stacked with other equipment. In case adjacent or stacked use is necessary. The medical device should be observed to verify normal operation in the configuration in which it will be used.
3. Consider the electromagnetic compatibility of the device (ex. power disturbance, radio frequency interference etc.) Please use it indoor only.
4. Over high frequency measurements may result in blood flow interference, which is likely to cause uncomfortable sensations, such as partial subcutaneous hemorrhage, or temporary numbness to your arm. In general, these symptoms should not last long. However, if you do not recover in time, please seek your medical practitioners for help.

Device Overview

◆ Part names and product components

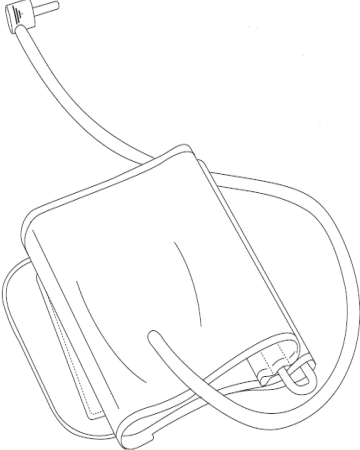

Arm Cuff With Tube

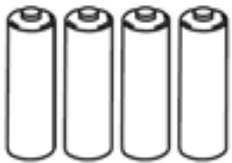







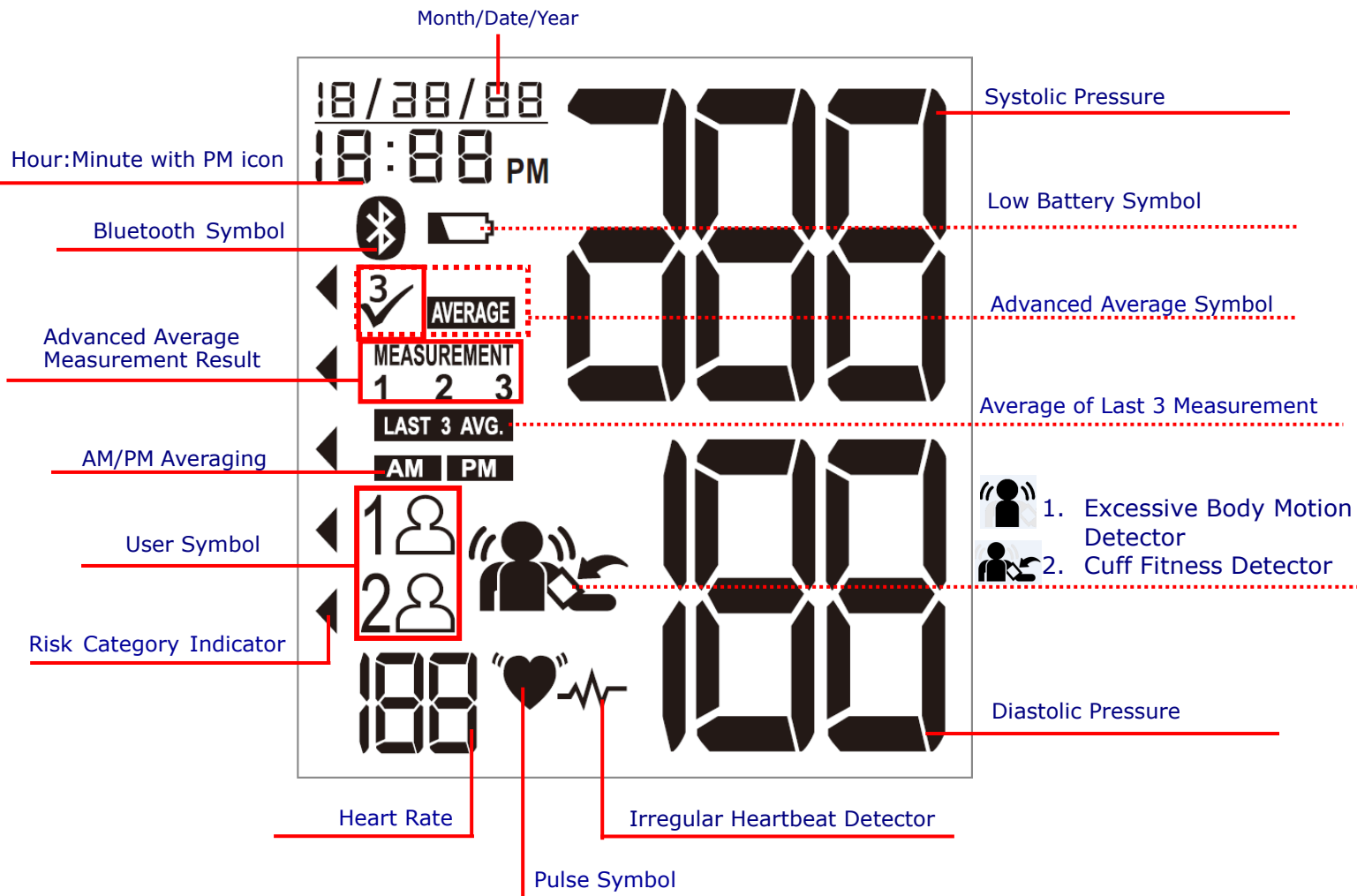



AAA "LR03" (1.5V)
Alkaline Battery X 4

Device Overview



◆ Unit display



Symbol Definitions

SYMBOLS	Definitions
 Low Battery Symbol	<p>This symbol appears when the battery power is extremely low or the polarity reverses.</p> <p>→ We suggest you replace all batteries with new ones, and make sure the +/- polarities are properly positioned.</p>
 Pulse Symbol	<p>Once pulse is detected, the symbol flashes with each pulse beat.</p>
 Irregular Heartbeat Detector	<p>This symbol appears when the user was talking, moving, shaking, or an irregular heartbeat was detected during measurements.</p> <p>→ Our suggestion: Please do not talk or move during measurements. Repeat the measurement after resting for at least 5 minutes, and restart your measurement while sitting down comfortably and quietly.</p>
 Risk Category Indicator	<p>The arrowhead points out the specific Risk Category that your measurement reading fits in.</p>
 Advanced Average Symbol	<p>This symbol appears when viewing an advanced average</p>
 Advanced Average Measurement Result	<p>Indicates which measurement is being taken, or which measurement is being viewed from an advanced average reading.</p>
 Average of Last 3 Measurements	<p>This symbol appears when LCD displays average value of last 3 readings.</p>
 AM/PM Averaging	<p>This symbol appears when LCD displays an average from the last 3 morning or last 3 evening measurements.</p>
 User 1	<p>Appears when the monitor is operated by User 1.</p>
 User 2	<p>Appears when the monitor is operated by User 2.</p>
 Excessive Body Motion Detector	<p>This symbol appears if body movement is detected during measurement, especially the movement on the arm that the blood pressure monitor is worn on.</p> <p>Notice: The measured blood pressure reading may not be accurate if the icon is displayed.</p>

Symbol Definitions

 Cuff Fitness Detector	This symbol appears if the cuff was wrapped incorrectly, which is too tight or too loose. This is the function aid in detecting if the cuff is wrapped properly.
 Bluetooth Symbol	Under Bluetooth Data Transmission / Link Mode, LCD displays this symbol.

Features

◆ Risk Category Indicator (AHA 2017)

This device is equipped with Risk Category Indicator which classifies your blood pressure measurements into five stages (Normal, Elevated, Hypertension stage 1, Hypertension stage 2 and Hypertensive crisis) based on the blood pressure standards established by the American Heart Association (AHA). Besides, for yours and your loved ones' health, we further classify the five stages into numeral ranges, which sorts out hypertension symptoms more clearly. Moreover, to your convenience and readability, we use three corresponding colors to represent your measuring result. Refer to below comparison chart for details:

BLOOD PRESSURE CATEGORY	SYSTOLIC mm Hg (upper number)		DIASTOLIC mm Hg (lower number)	INDICATOR COLOR	
NORMAL	<120	and	< 80		Green
ELEVATED	120-129	and	< 80		Yellow
HIGH BLOOD PRESSURE (HYPERTENSION) STAGE 1	130-139	or	80-89		Red
HIGH BLOOD PRESSURE (HYPERTENSION) STAGE 2	140-180	or	90-120		
HYPERTENSIVE CRISIS (consult your doctor immediately)	>180	and/or	>120		

* Source : AHA 2017

After measurement, LCD displays the systolic and diastolic pressure, heart rate, date and time along with Risk Category Indicator bar. The higher the blood pressure, the higher the bar. Compare the bar with the three colors at the left of LCD display to know the classification of your blood pressure based on American Heart Association standard (AHA 2017).

***Note !**

When a person's systolic and diastolic pressures fall into different categories, the higher category should apply.

e.g. systolic pressure 181 and diastolic pressure 99 ⇒ Red category (Hypertensive crisis)

e.g. systolic pressure 110 and diastolic pressure 95 ⇒ Red category (Hypertension stage 2)

***Note !**

The above table is not exact for classification of blood pressure and it's intended to be used as a guide in understanding non-invasive blood pressure measurements.

Usually this is not a cause for concern; however we recommend you consult with your physician for proper diagnosis or seek medical advice according to our recommendation mentioned above. Please note that the device does not appropriate to diagnose hypertension, and it is only for user reference on blood pressure monitoring.

Features

◆ Advanced Average Function

The advanced average function automatically takes and averages 3 readings in a row, with 1 minute rest intervals between each measurement. To deactivate this feature and take only one single reading, slide the switch on the back to the OFF position.

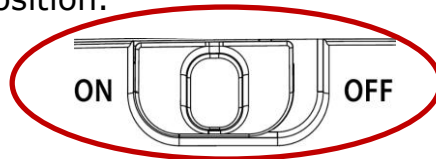

◆ Irregular Heartbeat Detector

The symbol  will appear on screen indicating a certain heartbeat irregularity was detected during measurement.

The heartbeat rhythm that is more than or less than 25% from the average rhythm is usually defined as an irregular heartbeat rhythm. Talking, moving, shaking or an irregular pulse during the measurement can result in the appearance of this symbol.

Usually this is not a cause for concern, however if the symbol appears often, we recommend you seek medical advice.

And please note that the device does not replace a cardiac examination, but serves to detect pulse irregularities at an early stage.

***Note !**

- The pulse display is not suitable for checking the frequency of heart pacemakers. If a certain pulse irregularity is detected during measurement often, we recommend you seek medical advice
- As a safeguard, we recommend that if you have arrhythmias such as atrial or ventricular premature beats and atrial fibrillation or any other special conditions you should check with your physician before using your device.
- The IHB function is designed neither for use by people with arrhythmias nor for diagnosing or treating an arrhythmic problem. In order to filter the unstable status of user and avoid affecting the detection of heart rate from any movement, shaking or talking in the beginning of measurement, the method of averaging heartbeat intervals of subject device is calculated with the three proper heartbeat pulses detected in the beginning of measurement and that is different from a strict mathematical averaging of all recorded intervals.
- At least 3 beats with 25% or greater difference from the average heartbeat interval will generate the IHB icon on the screen.

Bluetooth Transmission

HL868AX features a built-in "Bluetooth Data Transmission" function, which enables the device automatically transmits measuring results to paired Bluetooth-enabled device after measurement. When connection is established, BPM would transmit memory data such as Measure Date, Systolic, Diastolic and Pulse to the Bluetooth enabled device.

Before attempting to sync the device with your smart device, make sure Bluetooth function is turned ON in both your smart device and the monitor, and make sure your Bluetooth-enabled device has downloaded the App. See the "App for Bluetooth" section for details.

◆ Transmit Readings

Bluetooth function can be activated only when Bluetooth is turned ON. To turn on Bluetooth, please refer to **Setting Year, Date and Time** section.

1. There are 2 ways to activate Bluetooth Function.

a. Automatically Activate:

When a measurement is completed, the device activates Bluetooth Function automatically, and Bluetooth symbol  will be flashed on the screen.

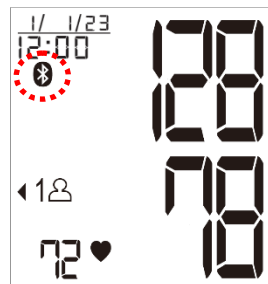

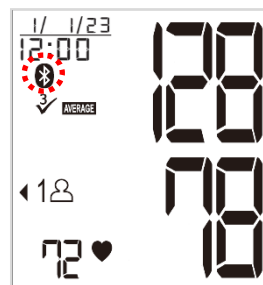

Single Measurement
Bluetooth Symbol Flashing



ADV Measurement
Bluetooth Symbol Flashing

b. Manually Activate (when the Bluetooth function is ON):

Under sleeping mode, user can press the **M+*** button for 3 seconds to activate Bluetooth function, and Bluetooth symbol  will be flashed on the screen.

2. If HL868AX is connected successfully to your smart device, Bluetooth symbol  will appear on the screen.

Bluetooth Transmission

◆ Date/Time Synchronization

1. The date/ time setting of HL868AX can be synchronized by Bluetooth-enabled device (e.g. smartphone) which has downloaded and installed DailyChek® application software.
2. When Bluetooth connection is established, the Bluetooth-enabled device can send command with the date/ time information to BPM and the BPM's date/ time will be updated.

◆ App for Bluetooth

Download and install "DailyChek®" app on your smart device from Google Play or App store.

System requirement of the Bluetooth-enabled device

- Bluetooth 4.2 for Android 6.0 or above
- Bluetooth 4.2 for iOS 7.0 or above

***Note !**

- HL868AX is subject to and complies with electromagnetic compatibility (EMC) standard of IEC 60601-1-2, EN 301 489-1, EN 301 489-17, EN 300 328 and U.S. federal guidelines, Part 15 of the FCC (Federal Communications Commission) rules for devices with RF capability. These guidelines help ensure that your device will not affect the operation of other nearby devices. Additionally, other devices should not affect the use of your device.
- Other wireless devices that are in use nearby, such as a cell or mobile phone, or a wireless network, may prevent or delay the transmission of data from your device to paired Bluetooth-enabled device. Moving away from the source of the interference or turning off these devices to resolve the problem.
- Make sure HL868AX and paired Bluetooth-enabled device are within acceptable distance (no more than 10 meters) with each other. If not, put them closer.
- Be sure to select the correct user on the monitor before your blood pressure measurement begins.
- Bluetooth data transmission is not available under measurement.

***Note !**

- Without any operation in 1 minute, the device shuts off automatically and Bluetooth Transmission will be turned OFF.

Installing Batteries

When low battery symbol  appears on the display or nothing appears on the display when the power is switched on, please change the batteries.

Replace all the batteries with new ones and do not mix new and old batteries. All batteries used must be the same type. Do not mix alkaline, standard (carbon-zinc) or rechargeable (cadmium) batteries either. It may shorten the battery life or cause the device to malfunction.

Slide the battery cover and insert 4 AAA (1.5V, LR03) alkaline batteries into the battery compartment as shown on the figure below. Make sure the polarities "+" and "-" ends are coinciding with similar markings engraved on the battery housing.

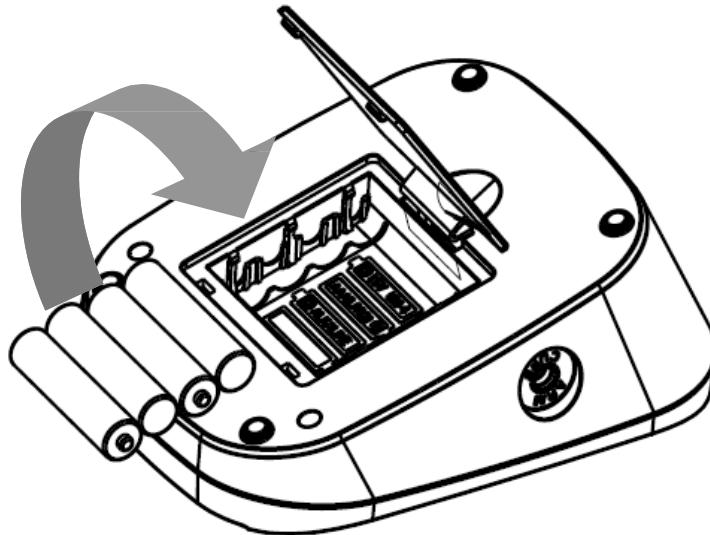

***Attention !**

- Batteries are hazardous waste. Do not dispose of them together with the household garbage. Please discard worn-out batteries to the recycling site according to local regulations.
- Keep the battery away from children in case they choke on it.
- To prolong the battery life and prevent damage caused by leakage, remove the batteries from the device if the device is not to be used for a long period.
- Memories (if any) will not be deleted during battery replacement.
- Please replace all worn-out batteries with new ones when you are operating the Bluetooth transmission function and the low battery symbol  appears on the display.
- After replacing the batteries, the date and time will be reset.

Using the AC/DC Adapter

This monitor is designed for operation with batteries or an AC/DC adapter.

Please use only a compatible AC/DC adapter with required voltage and current as indicated in this manual.

***Note !**

- No batteries are needed when operating with an AC/DC adapter.
- Please unload the batteries when operating with an AC/DC adapter for an extended period of time.
- Leaving the batteries in the compartment for a long time may cause leakage, which may lead to damage of the unit.
- Recommend Adapter specification, do not use otherwise:

Model: FranMar International, FRM06-S05-UU

Rating:

Input: 100-240V, 50/60 Hz, 0.2A

Output: 5V, DC, 1.2A 

***Note !**

When you use the blood pressure monitor with AC/DC adapter, do not position the device to make it difficult to disconnect the adapter plug.

Applying the Cuff

- ❑ Wrap the cuff on a bare arm or over thin clothing. Thick clothing or a rolled up sleeve will cause inaccurate blood pressure measurements.
- ❑ Press your brachial artery approximately 1 inch (2 ~ 3 cm) above the elbow on the inside of your left arm to determine where your strongest pulse is.
- ❑ Slide the end of arm cuff furthest from the tube through the metal ring to a loop. The smooth cloth should be on the inside of the cuff.
- ❑ If the cuff is located correctly, the velcro will be on the outside of the cuff, metal ring will not touch your skin, and the arrow on the cuff should be fallen within the Proper Fit Range (Figure 1).
- ❑ Put left arm through the cuff loop. The tube should lie over the brachial artery on the inner part of the arm.
The bottom edge of the cuff should be approximately. 1 inch (2 ~ 3 cm) above the inner elbow.
- ❑ Pull the end of the cuff so that it tightens evenly around your arm, allowing room for 2 fingers to fit between the cuff and your arm (Figure 2).
- ❑ When the cuff is positioned properly, press the velcro firmly against the pile side of the cuff and make sure the cuff is not slipped during measurement, and the arrow falls within the Proper Fit Range.
- ❑ Sit on a chair comfortably, put your feet flat on the floor and lay your forearm on the table, make sure your back and arm supported, legs uncrossed, so that the cuff is at the same level as your heart(Figure 3).
- ❑ Relax your arm and turn your arm upward.
- ❑ Make sure there are no kinks in the air tube.

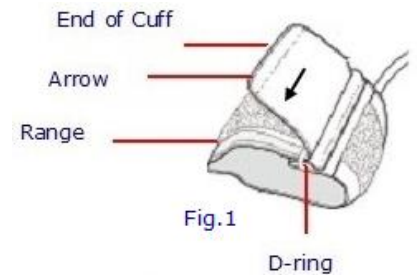

Note !

- Fit the cuff snugly, leaving enough space for 1 inch (2 ~ 3 cm) between the inner elbow and the lower edge of the cuff, or the measurement may not be accurate.
- In case the cuff kept pumping up non-stop, unwrap the cuff at once.
- Do not wrap the cuff around any body part other than your arm.
- Do not use this device if your arm has any wound or injury, especially after surgery on the arm. Otherwise, it may cause infection at the surgical site. Please use the device after the wound has healed.
- If there is one of situations mentioned below, please dispose the device without reuse.
- If you have any infectious skin disease or the device is used by users with infectious skin disease, please do not continue using the device.
- Before using the device, user should check the appearance of cuff. If you notice blood or other soil on cuff, please do not use this device.

Measurement Procedure

◆ Switch on the Monitor

- Put in 4 AAA 1.5V (LR03) alkaline batteries.
- All segments appear on the screen for 1.5 seconds.
- The monitor will automatically turn to sleeping mode (all LCD segments are cleared).

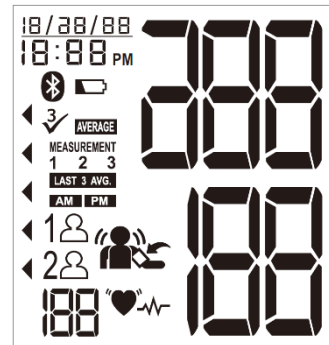

◆ Setting Year, Time and Date

1. Set Manually.

- Under sleeping mode, to enter setting mode press **USER/⊙** button for 3 seconds, then Month digit flashes.
 - Press **M+/*** button to select current month. **USER/⊙**
- When above settings are done,

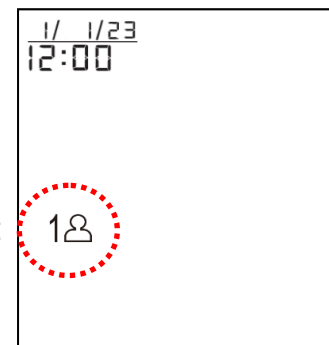

Press

USER/⊙ button to adjust current DATE. Press **M+/*** button to select current date.

- Continue to set current YEAR, HOUR (1, 2.....12PM, 1PM.....,12) and MINUTE (00,01.....,59) by following Step B.
- Users can adjust MONTH-DATE-YEAR-HOUR-MINUTE in an orderly manner. **USER/⊙** Press **USER/⊙** button to switch to the Bluetooth setting.

2. Using your Bluetooth smart device.

The date and time on your monitor can be automatically updated, when you connect it with your smart device.

Once the date and time have been successfully synced, future readings will automatically have the correct date and time.

◆ Turning Bluetooth Function ON/OFF

USER/⊙ Press button to enter the Bluetooth setting. The default setting of this function is **M+/*** ON. Press **USER/⊙** button to turn Bluetooth function ON or OFF.

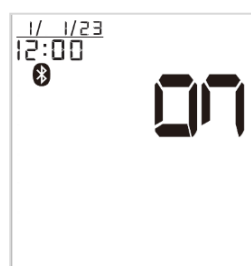

Measurement Procedure

Bluetooth function ON

Bluetooth function OFF

◆ Taking a Measurement

A. Check and select functions of advanced average mode if needed.

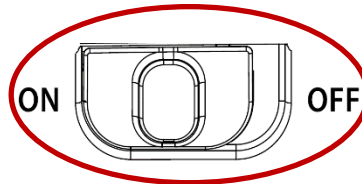

1. If functions of advanced average mode is on, the ³✓ symbol will be shown on the display, press **START/STOP** button to start an advanced average measurement.
2. If functions of advanced average mode is off, press **START/STOP** button to start single measurement.

B. Press **USER/⊙** button to select the user (see LCD Displays below).

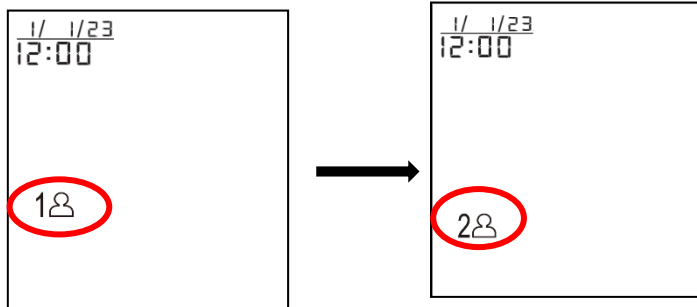

C. Start a Single Measurement:

1. Make sure the advanced average function switch is turned off.
2. As the cuff inflates, the monitor automatically determines your ideal inflation level. This monitor detects your blood pressure and pulse rate during inflation. The Pulse Symbol (♥) flashes at every heartbeat. Remain still and do not move until the entire measurement process is completed.

***Note !**

- If the cuff does not stop inflating, remove the cuff at once.
- To stop measurement, press **START/STOP** button. The cuff will deflate immediately after the button is pressed.

Measurement Procedure

3. After the monitor has determine your blood pressure and heart rate, the cuff automatically deflates. Your systolic pressure, diastolic pressure, pulse rate and corresponding Risk Category Indicator, Irregular Heartbeat Detector and Excessive Body Motion Detector (if any) are displayed with date and time for 1 minute and save results to memory automatically.
4. After measurement is completed, the device activates Bluetooth function automatically and the Bluetooth symbol will flash on the screen.
If the monitor cannot be connected to paired Bluetooth-enabled device over 45 seconds, LCD will display Error message "E4" and Bluetooth will be turned off.

D. Start an Advanced Average Measurement: The monitor will take 3 continuative measurements.

1. Make sure the advanced average function switch turned on. With the cuff wrapped around your upper arm, press **START/STOP** button to start the measurement. All display units appear on the screen, and will automatically start the 1st measurement ("1" flashes while measuring).
2. After the 1st measurement is finished, measuring result will not be shown, and display turns to 1 minute countdown directly for the 2nd measurement.
3. When times out, the monitor starts the 2nd measurement ("2" flashes, "1" stays non-flashing while measuring).
4. After the 2nd measurement is finished, measuring result will not be shown, and display turns to 1 minute countdown directly for the 3rd measurement.
5. When times out, the monitor starts the 3rd measurement ("3" flashes, "1" and "2" stays non-flashing while measuring)
6. As the cuff inflates, the monitor automatically determines your ideal inflation level. This monitor detects your blood pressure and pulse rate during inflation. The Pulse Symbol (♥) flashes at every heartbeat. Remain still and do not move until the entire measurement process is completed.

Measurement Procedure

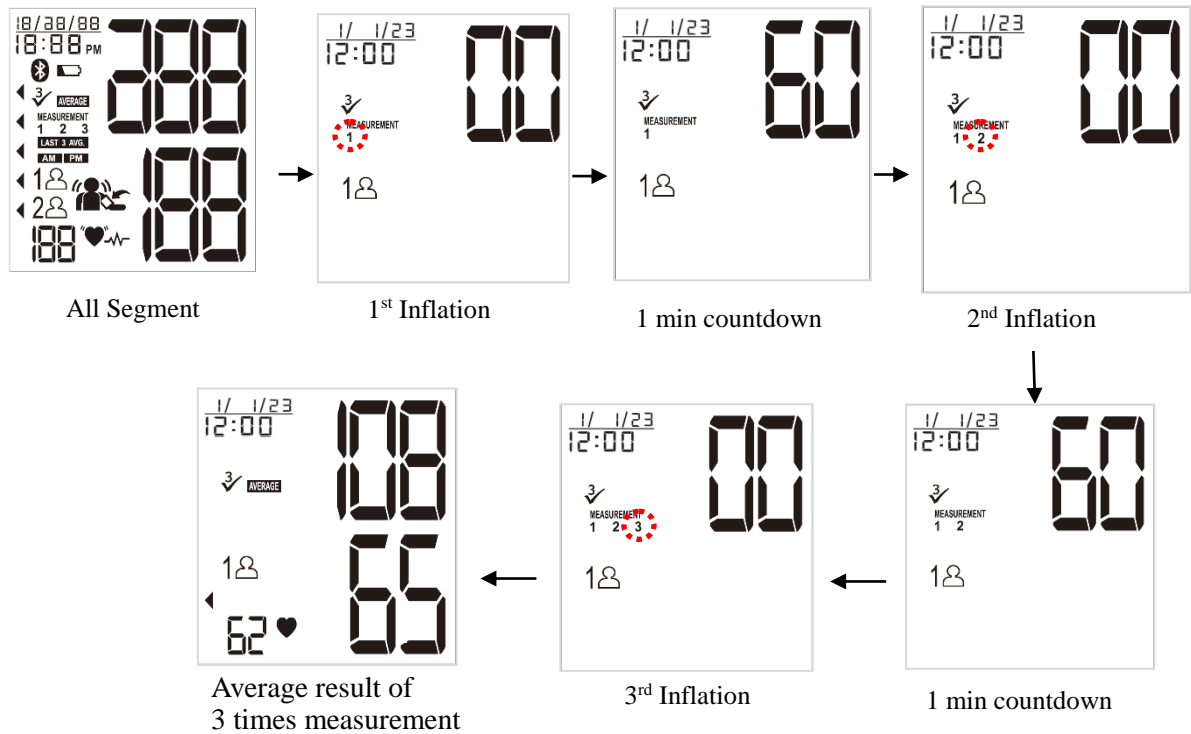

7. After the monitor has determine your blood pressure and pulse rate, the cuff automatically deflates. Your systolic pressure, diastolic pressure, pulse rate and corresponding risk category indicator and irregular heartbeat detector, and excessive body motion detector (if any) are displayed with date and time for 1 minute and save results to memory automatically.
8. After measurement is completed, the device activates Bluetooth function automatically and the Bluetooth symbol will flash on the screen.
If the monitor cannot be connected to paired Bluetooth-enabled device over 45 seconds, LCD will display error message "E4" and Bluetooth will be turned off.
9. Press **USER/⊙** button to review individual measurement result.

***Note !**

1. Do not inflate the cuff until it is wrapped around your upper arm.
2. To stop measurement, you may press **START/STOP** button.
3. **M+/*** Press button to enter memory mode.
4. **USER/⊙** Press button 3 seconds to Date/ Time setting mode.
5. Press **START/STOP** button to stop measurement and turn to sleeping mode.
6. The monitor will automatically switch to sleeping mode if no operation in 1 minute.



Memory Function













◆ Storing Data

After each measurement, the systolic and diastolic pressure, heart rate, risk category indicator, irregular heartbeat detector, and excessive body motion detector (if any) with date and time will be automatically stored.

The monitor features 2 user memory capabilities. Each user holds the last 120 measurements, and automatically replacing the oldest data with new one.

◆ Memory Function

- A. Press **M+/** button to enter memory mode.
- B. Press **M+/** button to see previous measuring results, including average of last 3 measurements, an advanced average measurement, AM/PM average and individual measurement.

	An average of advanced average measurement USER/Ⓢ (Press button to review individual readings)			
<table border="1" style="width: 100%; text-align: center;"> <tr> <td data-bbox="268 1243 373 1344">  </td> <td data-bbox="373 1243 493 1344">  </td> <td data-bbox="493 1243 598 1344">  </td> </tr> </table>				
				
	An average of Last 3 Measurements			
	An average from the last 3 morning or last 3 evening measurements.			
Note: The advanced average and its 3 individual measurements are counted as 4 readings when stored in memory.				

Memory Function

◆ Recalling Data

A. Select user first.

M+/* B. Press  button to enter memory mode. If there is no data stored before, nothing (except month, date, and time) will be appeared on the display. If yes, the first reading will be the average of last 3 measurements.

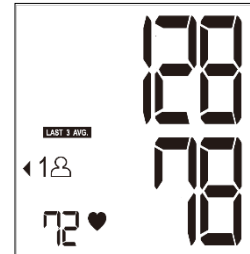



Average of Last 3 Measurements

(The advanced average result and its individual measurements will not be included as the average of last 3 measurements. See the example below.)

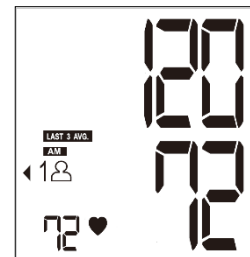
M+/* C. Press  button again, LCD displays average of latest 3 AM measurements, and then is average of latest 3 PM measurements. If fewer than 3 measurements in AM or PM, the average will not be displayed.





SYMBOL	Status
AM	An average of Last 3 Morning Measurements (4:00 AM – 12:00 PM)
PM	An average of Last 3 Nighttime Measurements (6:00 PM – 2:00 AM)

M+/* D. Press  button again, LCD displays the single measurement result or the average of advanced average measurement (if any). Press  button to read 3 results of advanced average measurement.

USER/⊕

M+/*

M+/*

- E. Every new press of the  button will recall a previous reading. The latest reading will be recalled first. Press  button repeatedly to review the previous readings stored in the memory.
- F. To stop reading memories, press **START/STOP** button to switch to sleeping mode.

Memory Function

<e.g. 59th result is an advanced average result :>

- Press **USER/⊙** button to read 3 individual results (58th, 57th and 56th) of advanced average (59th)

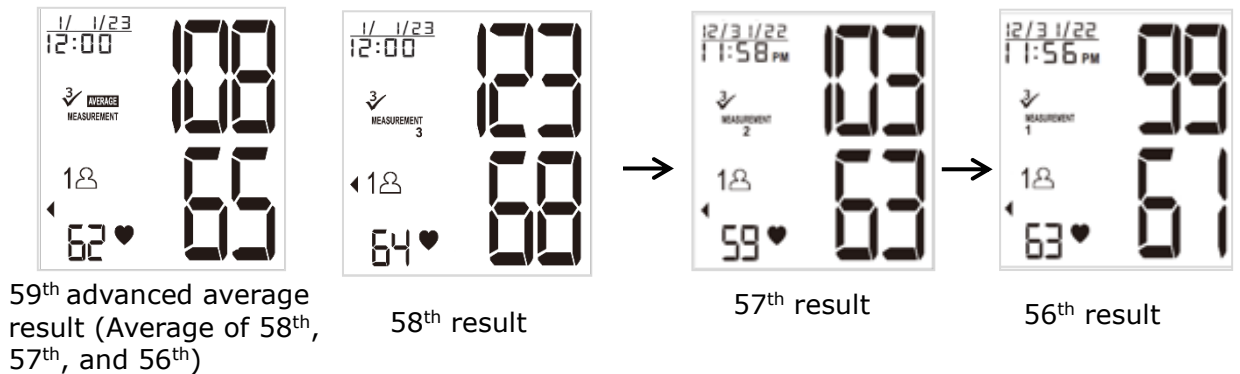

- Average of the last 3 measurements is the average of 60th, 55th and 54th results. (59th, 58th, 57th and 56th results are excluded).

◆ Erasing Data

- Select User first.
- Press **M+/*** button to enter memory mode.
- Press and hold **M+/*** **USER/⊙** buttons at the same time, the data will be erased automatically. LCD Displays "CLR" for 3 seconds.
- To confirm deletion, press **M+/*** button and no data should appear.



Note: Once deleted, your data can NOT be restored.

Storage and Maintenance

◆ General Use

- ❑ Do not twist the cuff in any way.
- ❑ Do not press **START** button if the cuff is not wrapped around your upper arm.
- ❑ Do not drop the product and avoid any strong impacts.

◆ Maintenance

- ❑ Do not attempt to disassemble or change any parts of the monitor, only trained technicians are allowed to repair and disassemble the device, including the software upgrades, cuff, patches and maintenance because a substitution of a component different from supplied might result in measurement error.
- ❑ If any suggestion or service is requested, please consult your service station.
- ❑ Do not implement the maintenance procedures for equipment during measurement.

To ensure that your device is in optimal use and to avoid damage, please refer to the following instructions:

- ❑ Clean the device and cuff with a soft dry cloth, or
- ❑ Use a dry cloth with water to clean the device (do not flush it directly, do not soak it in water, and hold the device dry), or
- ❑ Do not use detergent or any strong chemicals to clean the device.
- ❑ Make sure the cuff is completely dry before using.

According to the use environment of the sphygmomanometer, the recommended disinfection method and frequency are as follows:

- ❑ Only use it yourself (home use), it can be cleaned at ordinary times, and wipe it once a month with a commercially available 75% alcohol cotton sheet (for the cuff) for more than 30 seconds each time.
- ❑ If it is used for more than one person (home use), it can be cleaned at ordinary times. It is disinfected once a week (for the cuff belt) with a commercially available 75% alcohol cotton sheet, for more than 30 seconds each time.
- ❑ After cleaning / disinfecting/ before using, please make sure that there are no blood stains or soil on the LCD, the device and cuff, If there is any blood stains or soil, please dispose the device without reuse.

Storage and Maintenance

- ❑ If it is used in a complex environment (such as a hospital) or after multiple people (non-family), please discard the old cuff and replace it with a new one.

◆ Storage

- ❑ If the device is not to be used for a long time, please remove the batteries from the device (leaking of battery acid can cause the device to malfunction).
- ❑ Always store the unit in the storage case after use. It is intended to be transported or stored in a carrying case between uses.
- ❑ Do not place the device directly under sunlight, in high temperature, or in humid or dusty places.
- ❑ Do not store the device in extremely low (less than $-13^{\circ}\text{F}/-25^{\circ}\text{C}$) and high (more than $158^{\circ}\text{F}/70^{\circ}\text{C}$) temperature, nor in a place its humidity exceeds 93% R.H.

Troubleshooting

SYMBOLS/SYMPTOMS	CONDITIONS/CAUSES	INDICATION/ CORRECTION
Unit does not turn on when START/STOP button is pushed.	Worn-out batteries.	Replace them with 4 new AAA (LR03) alkaline batteries.
	Battery polarities have been positioned incorrectly.	Re-insert the batteries in the correct positions.
EE Measuring Error Symbol appears when blood pressure value displayed is excessively low or high.	Cuff has been placed incorrectly.	Wrap the cuff properly so that it is positioned correctly.
	Did you talk or move during measurement? Shaking of the arm with the cuff on	Measure again. Keep arm steady during measurement.
E1 Measuring Error Symbol	Air circuit abnormality. Cuff tube may not be plugged into monitor correctly.	Check cuff connection. Measure again.
E2 Measuring Error Symbol	Inflation pressure exceeding 300 mmHg.	Switch the unit off, then measure again.
E3 Measuring Error Symbol	Can't determine blood pressure measurement data.	Wrap the cuff properly and keep steady. Measure again.
	Cuff is worn improperly, or the shape of the upper arm is unusual (for example, the circumference of the upper arm differs largely from the circumference of the forearm), excessive gap might be exist between the arm cuff and the arm.	Wrap the cuff properly and keep steady. Measure again. If you have any question about the cuff wearing and/or measurement result, please consult your healthcare professional.
E4 Measuring Error Symbol	If HL868AX cannot be connected to paired Bluetooth-enabled device over 45 seconds, LCD will display Error message "E4" and Bluetooth will be turned off.	Please press M+/* button for 3 seconds to start Bluetooth function.
 Excessive Body Motion Detector Notice: The measured blood pressure reading may not be accurate if the icon is displayed.	Body movement during measurement, especially, the movement on the arm the blood pressure monitor is worn on. e.g. Talking, moving or shaking of the arm with the cuff on while measurement.	Measure again. Keep arm steady during measurement.
	Cuff is worn improperly, or the shape of the upper arm is unusual (for example, the circumference of the upper arm differs largely from the circumference of the forearm), excessive gap might be exist between the arm cuff and the arm.	Wrap the cuff properly and keep steady. Measure again. If you have any question about the cuff wearing and/or measurement result, please consult your healthcare professional.

Troubleshooting

 <p>Cuff Fitness Detection Symbol</p>	<p>The cuff was wrapped incorrectly (for example too loosely or too tightly).</p>	<p>Please reference "Applying the Cuff" section to wrap the cuff correctly.</p>
<p>BPM cannot communicate with Bluetooth-enabled device</p>	<p>Pairing has not been completed.</p>	<p>Please re-pairing the BPM and Bluetooth-enabled device with each other.</p>
	<p>Bluetooth function is not turn on.</p>	<p>Please M+/* press button for one time under sleep mode.</p>
	<p>The distance between BPM and Bluetooth-enabled device is out of transmitting range.</p>	<p>Please make sure the acceptable distance (≤ 10 meters) with each other.</p>
	<p>Use an incompatible Bluetooth-enabled device.</p>	<p>Please refer to "Bluetooth compatibility" and "RF Specification"</p>
	<p>Use non-Bluetooth-enabled device.</p>	
<p>Unexpected loss of electrical/mechanical integrity.</p>	<p>Re-insert the batteries and try again.</p>	
		<p>Return the device to your local distributor or importer.</p>
<p>Note: If "EP" appears on the display, just return the device to your local distributor or importer.</p>		

Limited Warranty

◆ **Warranty For Two Years from the manufacturing date**

Please note that this warranty does not cover damage caused by misuse or abuse; accident; the attachment of any unauthorized accessory; alteration to the product; improper installation; unauthorized repairs or modifications; improper use of electrical/power supply; loss of power; dropped product; malfunction or damage of an operating part from failure to provide manufacturer's recommended maintenance; transportation damage; theft; neglect; vandalism; or environmental conditions; loss of use during the period the product is at a repair facility or otherwise awaiting parts or repair; or any other conditions whatsoever that are beyond the control of importers or distributors.









Specifications

Model Number	HL868AX
Measurement Method	Oscillometric
Rated Range of Cuff Pressure	0~300 mmHg
Rated Range of Determination	40~280 mmHg
Measurement Range of Heart Rate	40~199 Beats/Minute
Accuracy	Pressure: ± 3 mmHg Pulse: $\pm 5\%$ Max.
Inflation	Automatic Inflation (Air Pump)
Deflation	Automatic Air Release Control Valve
Display	Liquid Crystal Display
Memory	240 Memory Total for 2 Users
RF Type	Bluetooth 5.0 BLE
Unit Dimensions	4.5 X 5.6 X 1.9 inch (L X W X H) 114 X 143 X 46 mm (L X W X H)
Unit Weight (Cuff & Batteries Excluded)	269.8 g \pm 5 g (9.51 oz \pm 0.17 oz)
Cuff Size	UC01:Universal size cuff (9" ~17"/23 ~ 43 cm)
Storage/Transportation Environment	Temperature: -25°C ~70°C (-13°F ~158 °F) Humidity: \leq 93% R.H.
Operation Environment	Temperature: 5°C ~ 40°C (41°F ~104°F) Humidity: 15% ~ 93% R.H. Atmospheric pressure: 700hPa ~ 1060hPa
Power Supply	1. DC 6V, AAA "LR03" (1.5V) Alkaline Battery x 4 2. DC 5V 1.2A AC/DC adapter (Optional)
Battery Life	Approx. 200 Measurements
Shelf Life (battery)	3 years (Temperature: 20 \pm 2°C; Relative humidity: 65 \pm 20%RH)
Product Life	5 Years (4 times per day)
Sleeping Mode	Without any operation for 1 minute, device automatically shuts off
Accessories	4 AAA (LR03) Alkaline Batteries, Arm Cuff with Tube, Instruction Manual, Pouch

***The contents of this manual and the specifications of the device covered by this manual are subject to change for improvement without notice.**

Note

Explanation of symbols:

Symbol	Explanation	Health & Life Information
	Refer to instruction manual/booklet	-
	TYPE BF Applied Part	-
	To avoid inaccurate results caused by electromagnetic interference	Warning: Portable RF communications equipment (including peripherals such as antenna cables and external antennas) should be used no closer than 30cm (12 inches) to any part of the device, Otherwise, degradation of the performance of this equipment could result.
	Waste of electrical and electronic equipment (WEEE)	Discard the used product to the recycling collection point according to local regulations
	Serial number	 YYMMXXXXXX
	Ingress Protection Rating	First characteristic numeral- Degree of protection against access to hazardous parts and against solid foreign objects N1=2 (Protected against solid foreign objects of 12.5 mm Ø and greater) Second characteristic numeral- Degree of protection against ingress of water N2=2 (Protected against vertically falling water drops when ENCLOSURE tilted up to 15°)
	Non-ionizing electromagnetic radiation	-

Device information:

- Internally powered equipment
- Not suitable for use in presence of flammable anesthetic mixture with air or with Oxygen or nitrous oxide
- Continuous operation with short-time loading

Manufacturer: HEALTH & LIFE CO., LTD.

9F, No. 186, Jian Yi Road, Zhonghe District 23553, New Taipei City, Taiwan
www.healthandlife.com.tw

Distributor: HoMedics USA, LLC

3000 N. Pontiac Trail, Commerce Township, MI 48390

Phone: 1-800-466-3342

Note

***Note !**

This equipment has been tested and found to comply with the limits for a Class B digital device, pursuant to Part 15 of the FCC Rules. These limits are designed to provide reasonable protection against harmful interference in a residential installation.

This equipment generates uses and can radiate radio frequency energy and, if not installed and used in accordance with the instructions, may cause harmful interference to radio communications. However, there is no guarantee that interference will not occur in a particular installation. If this equipment does cause harmful interference to radio or television reception, which can be determined by turning the equipment off and on, the user is encouraged to try to correct the interference by one or more of the following measures:

The user is encouraged to try to correct the interference by one or more of the following measures:

- Reorient or relocate the receiving antenna.
- Increase the separation between the equipment and the receiver.
- Connect the equipment into an outlet on a circuit different from that to which the receiver is connected.
- Consult the dealer or an experienced radio/TV technician for help.

FCC RF Radiation Exposure Statement:

1. The equipment complies with FCC RF exposure limits set forth for an uncontrolled environment.
2. The equipment must not be co-located or operation in conjunction with any other antenna or transmitter.

FCC Label Compliance Statement:

This device complies with Part 15 of the FCC Rules. Operation is subject to the following two conditions:

- (1) this device may not cause harmful interference, and
- (2) this device must accept any interference received, including interference that may cause undesired operation.

***Note !**

To assure continued FCC compliance:

Changes or modifications not expressly approved by the manufacturer could void the user's authority to operate the equipment.

HL868AX essential performance per IEC 80601-2-30 additional essential performance requirements:

- 201.12.1.102 Limits of the error of the manometer from environmental conditions

Over the temperature range of 5 °C to 40 °C (41 °F ~ 104 °F) and the relative humidity range of 15 % to 93 %(non-condensing), the maximum error for the measurement of the CUFF pressure at any point of the NOMINAL measurement range shall be less than or equal to ± 3 mmHg (± 0.4 kPa) or 2 % of the reading, whichever is greater.

- 201.12.1.107 Limits of the change in error of the blood pressure determination

The laboratory limits of the change in error of the BLOOD PRESSURE DETERMINATION of the AUTOMATED SPHYGMOMANOMETER shall be less than 3 mmHg (0.4 kPa).

Appendix

◆ Guidance and manufacturer's declaration – electromagnetic emissions

The device is intended for use in the electromagnetic environments listed below, and should only be used in such environments:

Emissions test	Compliance	Electromagnetic environment – guidance
RF emissions CISPR 11	Group 1	RF energy is used only to maintain device's operation. Therefore, its RF emissions are so low that it's not likely to cause any interference in nearby electronic equipment.
RF emissions CISPR 11	Class B	The device is suitable for use in all establishments, including domestic establishments, and those directly connected to the public low-voltage power supply network that supplies buildings used for domestic purposes.
Harmonic emissions IEC 61000-3-2	Class A	
Voltage fluctuations/ flicker emissions IEC 61000-3-3	Complies	

◆ Guidance and manufacturer's declaration – electromagnetic immunity

The device is intended for use in the electromagnetic environments listed below, and should only be used in such environments:

Immunity test	IEC 60601 test level	Compliance level	Electromagnetic environment – guidance
Electrostatic discharge (ESD) IEC 61000-4-2	± 8 kV contact discharge ± 15 kV air discharge	± 8 kV contact discharge ± 15 kV air discharge	In the case of air discharge testing, the climatic conditions shall be within the following ranges: Ambient Temperature: 15°C ~ 35°C, Relative Humidity: 30% ~ 60%.
Power frequency (50 or 60 Hz) magnetic field IEC 61000-4-8	30 A/m 50 or 60 Hz	30 A/m 50 or 60 Hz	Power frequency magnetic fields should be at levels characteristic of a typical location in a typical commercial or hospital environment.
Electrical fast transient/burst IEC 61000-4-4	± 2 kV for power supply lines ± 1 kV for input/output lines	± 2 kV for power supply lines ± 1 kV for input/output lines	Mains power quality should be that of a typical commercial or hospital environment.
Surge IEC 61000-4-5	AC Power port ±1 kV Line to Line	AC Power port ±1 kV Line to Line	Mains power quality should be that of a typical commercial or hospital environment.
interruptions and voltage variations on power supply input lines IEC 61000-4-11	0% UT; 0.5 cycle At 0°, 45°, 90°, 135°, 180°, 225°, 270° and 315°. 0 % UT; 1 cycles 70 % UT; 25/30 cycles 0 % UT; 250/300 cycle	0% UT; 0.5 cycle At 0°, 45°, 90°, 135°, 180°, 225°, 270° and 315°. 0 % UT; 1 cycles 70 % UT; 25 cycles 0 % UT; 250 cycle	Mains power quality should be that of a typical commercial or hospital environment. If the user of the device requires continued operation during power mains interruptions, it is recommended that the device be powered from an uninterruptible power supply or a battery.

Appendix

◆ Guidance and manufacturer's declaration – electromagnetic immunity

The device is intended for use in the electromagnetic environments listed below, and should only be used in such environments:

Immunity test	IEC 60601 test level	Compliance level	Electromagnetic environment – guidance
Conducted RF IEC 61000-4-6	3V rms At 0.15-80 MHz 6V rms At ISM & Radio Amateur Freq.	3V rms At 0.15-80 MHz 6V rms At ISM & Radio Amateur Freq.	Portable and mobile RF communications equipment should be used no closer to any part of the device, including cables, than the recommended separation distance calculated from the equation applicable to the frequency of the transmitter.
Radiated RF IEC 61000-4-3 Proximity fields from RF wireless communications equipment IEC 61000-4-3	10 V/m at 80-2700 MHz AM Modulation And 9-28V/m at 385-6000MHz,Pulse Mode and other Modulation. The system shall be tested as specified in IEC60601-1-2 Table 9 for proximity fields from RF wireless communications equipment using the test methods specified in IEC 61000-4-3	10 V/m at 80-2700 MHz AM Modulation And 9-28V/m at 385-6000MHz,Pulse Mode and other Modulation. The system shall be tested as specified in IEC60601-1-2 Table 9 for proximity fields from RF wireless communications equipment using the test methods specified in IEC 61000-4-3	<p>Recommended separation distance</p> <p>Considering to reduce the minimum separation distance, based on RISK MANAGEMENT, and using higher IMMUNITY TEST LEVELS that are appropriate for the reduced minimum separation distance. Minimum separation distances for higher IMMUNITY TEST LEVELS shall be calculated using the following equation:</p> $E = 6/d \sqrt{P}$ <p>where P is the maximum power in W, d is the minimum separation distance in m, and E is the IMMUNITY TEST LEVELS in V/m.</p> <p>Field strengths from fixed RF transmitters, as determined by an electromagnetic site survey,a should be less than the compliance level in each frequency range.b</p> <p>Interference may occur in the vicinity of equipment marked with the following symbol: </p>
Note 1)	At 80 MHz and 800 MHz, the higher frequency range applies.		
Note 2)	These guidelines may not apply in all situations. Electromagnetic propagation is affected by absorption and reflection from structures, objects and people.		
a)	Field strengths from fixed transmitters, such as base stations for radio (cellular/cordless) telephones and land mobile radios, amateur radio, AM and FM radio broadcast and TV broadcast cannot be predicted theoretically with accuracy. To assess the electromagnetic environment due to fixed RF transmitters, an electromagnetic site survey should be considered. If the measured field strength in the location in which the device is used exceeds the applicable RF compliance level above, the device should be observed to verify normal operation. If abnormal performance is observed, additional measures may be necessary, such as reorienting or relocating the device.		
b)	Over the frequency range 150 kHz to 80 MHz, field strengths should be less than 3 V/m		

Appendix

Test specifications for enclosure port immunity to RF wireless communications equipment.

Test frequency (MHz)	Modulation	IMMUNITY TEST LEVEL (V/m)
385	Pulse modulation 18 Hz	27
450	FM \pm 5 kHz deviation 1kHz sine	28
710	Pulse modulation 217 Hz ^{a)}	9
745		
780		
810	Pulse modulation 18 Hz ^{a)}	28
870		
930		
1720	Pulse modulation 217 Hz ^{a)}	28
1845		
1970		
2450	Pulse modulation 217 Hz ^{a)}	28
5240	Pulse modulation 217 Hz ^{a)}	9
5500		
5785		
<p>NOTE: If necessary to achieve the IMMUNITY TEST LEVEL, the distance between the transmitting antenna and the ME EQUIPMENT or ME SYSTEM may be reduced to 1 m, The 1 m test distance is permitted by IEC 61000-4-3.</p>		
<p>a) The carrier shall be modulated using a 50% duty cycle square wave signal. b) AS an alternative to FM modulation, 50% pulse modulation at 18 Hz may be used because while it does not represent actual modulation, it would be worst case.</p>		

Blood Pressure Diary

Date :		Time :		<input type="checkbox"/> Before Meal
				<input type="checkbox"/> After
Systolic / Diastolic :				Pulse :
Date :		Time :		<input type="checkbox"/> Before Meal
				<input type="checkbox"/> After
Systolic / Diastolic :				Pulse :
Date :		Time :		<input type="checkbox"/> Before Meal
				<input type="checkbox"/> After
Systolic / Diastolic :				Pulse :
Date :		Time :		<input type="checkbox"/> Before Meal
				<input type="checkbox"/> After
Systolic / Diastolic :				Pulse :
Date :		Time :		<input type="checkbox"/> Before Meal
				<input type="checkbox"/> After
Systolic / Diastolic :				Pulse :
Date :		Time :		<input type="checkbox"/> Before Meal
				<input type="checkbox"/> After
Systolic / Diastolic :				Pulse :
Date :		Time :		<input type="checkbox"/> Before Meal
				<input type="checkbox"/> After
Systolic / Diastolic :				Pulse :
Date :		Time :		<input type="checkbox"/> Before Meal
				<input type="checkbox"/> After
Systolic / Diastolic :				Pulse :

P/N : 323103781

VER : A001

20230419