

ELCA

RADIOCONTROLS

User manual

MITO
Industrial radio remote control

AT MITO-MINI-915
Transmitting Unit

AR MITO-MINI-915
Receiving Unit



ELCA S.r.l. Via del Commercio, 7/b - 36065 Mussolente (VI) ITALY
www.elcaradio.com tel. +39 0424 578500 fax +39 0424 578520

User manual

INDEX

a. FEDERAL COMMUNICATIONS COMMISSION (FCC) CONFORMITY AND FREQUENCIES .. II

a.1 CONFORMITY II

a.2 FCC CONFORMITY STATEMENT II

a.3 FREQUENCIES II

a.4 MARKET II

1. USER MANUAL 1

2. USE INSTRUCTIONS 2

2.1 GENERAL INFORMATION 2

2.2 APPLICATIONS AND USE CONDITIONS NOT PERMITTED 2

2.3 INSTRUCTIONS FOR PROPER AND SAFE USE 3

2.4 TRANSMITTING UNIT AT MITO-MINI-915 4

2.5 RECEIVING UNIT AR MITO-MINI-915 6

2.6 STORING ACCESS CODES 8

2.7 INFORMATION FOR MAINTENANCE 10

2.8 INFORMATION FOR THE PROPER INSTALLATION OF THE RADIO REMOTE CONTROL SYSTEM 10

2.9 WARRANTY 11

2.10 DISPOSAL INFORMATION 11

3. PROGRAMMABLE FUNCTIONS 12

3.1 ACCESS TO PROGRAMMING MODE 12

3.2 FREQUENCY RANGE PROGRAMMING 12

3.3 AUTO-SHUTDOWN TIME PROGRAMMING 13

3.4 PIN CODE PROGRAMMING 14

3.5 LATCHED CONTROL PROGRAMMING 15

4. BATTERY CHARGER 16

4.1 OPERATING INSTRUCTIONS 16

5. TROUBLESHOOTING 17

5.1 TYPE OF TROUBLE 17

5.2 FUNCTIONAL TESTING OF TRANSMITTING UNIT 18

5.3 FUNCTIONAL TESTING OF RECEIVING UNIT 19

5.4 FUNCTIONAL TESTING OF CHARGING CYCLE 20

6. TECHNICAL FEATURES 21

6.1 GENERAL 21

6.2 FEATURES OF TRANSMITTING UNIT 21

6.3 FEATURES OF RECEIVING UNIT 21

6.4 FEATURES OF BATTERY CHARGER MITO-ION 22

ANNEX A 23

a. FEDERAL COMMUNICATIONS COMMISSION (FCC) CONFORMITY AND FREQUENCIES

a.1 CONFORMITY

Each MITO-MINI-915 serie's radio remote control working in the frequency band 920.000 - 921.150 MHz complies with Part 15 of standards FCC.

Transmitting Unit AT MITO-MINI-915 FCC ID: 2ABS7-ATMIMI915
Receiving Unit AR MITO-MINI-915 FCC ID: 2ABS7-ARMIMI915

a.2 FCC CONFORMITY STATEMENT

This device complies with part 15 of the FCC Rules.

Operation is subject to the following two conditions:

- (1) this device may not cause harmful interference, and
- (2) this device must accept any interference received, including interference that may cause undesired operation.

Any changes or modifications not expressly approved by the party responsible for compliance could void the user's authority to operate the equipment.

a.3 FREQUENCIES

The radio link between the units of ELCA MITO-MINI-915 series radio remote controls is built at one of the frequencies permitted by the US standards in force when the system is put on the market.

Frequency band	920.000 - 921.150 MHz
Transmitting power	meets FCC requirements
Available radio channels	24
Channel spacing	50kHz

a.4 MARKET

- MITO-MINI-915 serie's radio remote controls working in the frequency band 920.000 - 921.150 MHz can be used in the United States market.

1. USER MANUAL

Read this Manual before operating the Radio Remote Control.

For ease of reference, symbols have been placed at the side of paragraph titles to **highlight** important information contained in the text.



IMPORTANT!

To learn how to operate your radio remote control: operating instructions for radio remote control.



To become familiar with your radio remote control: radio remote control technical data.



Maintenance and troubleshooting.



To become thoroughly familiar with your radio remote control: detailed information on radio remote control..

Bold face is used to call attention to text that you should read carefully.

The content of this manual is subject to changes without notice and is not binding on ELCA.

This updated edition incorporates suggestions from our Customers to provide an effective tool supporting them in they day-to-day work.

This manual and any annexed documents are the property of ELCA and all rights are reserved. No parts of this publication may be reproduced or transmitted in any form or by any means, without permission in writing from ELCA.

The ELCA logo is a registered trademark.

The information contained in this manual are complementary to the instruction manual of the machine on which the remote control is installed. For the correct use of the machine with remote control, always refer to the instructions of its manufacturer.

Keep this manual and any attachments for the lifetime of the radio control for future reference.

The documentation that accompanies the remote control is always composed of:

- User's Manual
- Any attachments according to the configuration:
 - Control layouts, if it is a special configuration
 - Wiring diagram of the receiver, if the plant is supplied wired

WARNING!

Perform a careful risk analysis before installing the radio remote control on any machine.

2. USE INSTRUCTIONS

2.1 GENERAL INFORMATION



The ELCA Radio System Type MITO is an innovative family of low-power industrial radio remote controls, used to control appliances that do not require Stop safety function.

The ELCA Radio Remote Control System Type MITO is comprised of two main Units:

- a Transmitting Unit (AT) that sends the command selected by operator in the form of a sequence of digital data;
- a Receiving Unit (AR) that decodes the sequence of digital data for the machine to perform selected command.

The radio control system allows the operator free movement around the machine. The transmitting unit requires no cable connections and the operator can stand at a safe distance from the machine, in a position affording a better view of machine movements.

Each Radio remote control uses a unique identifier code set at the factory that cannot be modified. This way, each transmitting unit can only operate with the associated receiving units and will not conflict with other radio remote controls. One or more transmitting units can be associated to a given receiving unit through the identifier code learn procedure. Working frequency is automatically selected when the transmitter is activated from available low-noise frequencies. In service, any persistent radio noise will automatically trigger a frequency change without interrupting operation.

The special LBT (Listen Before Transmit) Full Duplex technology used by the MITO system allows the selection of low-noise frequencies, and also provides a 2-way communication link between transmitter and receiver, i.e. is capable of handling feedback information from the receiver. Such two-way communication ensures full control of the machine, as the receiver sends back an "acknowledge" signal after receiving each command to confirm that the command has been carried out. If the transmitter receives no "acknowledge" signal, it stops transmission alerting operator to the fact the safe transmission is not ensured.

The sophisticated signal coding / decoding protocol used by the system ensures high reliability of transmission data with a Hamming distance of 10 and above.

Product not suitable for use on machines for lifting things, people and all those applications which require a STOP command with safety function.

2.2 APPLICATIONS AND USE CONDITIONS NOT PERMITTED



The Radio Remote Control MITO, should NOT be used:

- for the control of devices in which both require the presence of a Stop safety command;
- for the control of devices for lifting persons;
- on machines that require the capability to operate in explosive atmosphere (ATEX);
- on equipment where the stop of the remote control is not sufficient to put in safety conditions the driven machine, which can then be a possible cause of danger;
- on machines where risk analysis is not possible or has given negative results;

2.3 INSTRUCTIONS FOR PROPER AND SAFE USE



IMPORTANT ! Radio remote control user MUST:

- Check the correct mechanical operation of the STOP button before every operation.
- Check the correct operation of the control devices.

If there is a deterioration in the correct operation of the STOP button or functional abnormalities in the control devices, the use of the radio remote control must be prohibited until the full restoration of the system's functionality.

- Use the transmitter unit by holding it or fastening it to the body in a safe and stable manner to avoid it accidentally falling.
- Be thoroughly familiar with the functions and features of the radio remote control and of the machine the receiving unit is connected to.
- Before activating any movement of the machine, ensure that the operator's position is such to ensure that:
 - There is NO danger of tripping
 - There is NO danger of loss of balance
 - Allow to follow the movements of the machine and the load in view.
 - Guarantee the safety conditions concerning those engaged in other operations, activities or work in the work area of the machine and operator.
- Turn off the transmitting unit whenever the work is suspended, even momentarily, even if the device is equipped with automatic shut-off.
- Switch-off the transmitting unit and disconnect the power supply of the receiver before performing any maintenance on the radio remote control or on the machinery.
- Do not leave the transmitting unit unattended and switched on.
- Remember that the transmitting unit can operate the machine even when placed indoors and far from the receiving unit, so improper use can cause severe damage to people and property
- Never wash the units with water jets, use a damp cloth only
- Do not use in shielded environments (e.g. inside the drum of the mixer).
- Charge the batteries in an environment that is not too hot, too cold, too humid or dusty.
- Keeping the batteries partially charged at all times can extend their useful life.
- Do not leave the batteries discharged for long periods.
- Charge the batteries at least once a year even if the unit has not been used since the last charge.

IMPORTANT ! The installer of the radio remote control must:

- Carry out a thorough risk assessment on the use of the machine with the radio remote control.
- Assess that there are no hazardous conditions in the event the radio remote control stops due to the loss of the radio link.
- Do not install the radio remote control on machines to which the safety of moving, lifting or transporting people is entrusted to the radio remote control.
- Do not install the radio remote control where explosion-proof characteristics are required of the radio remote control (EX).
- Secure the receiver so that it is facing the transmitter in normal use.
- Ensure that there are no metal obstacles between the transmitter and receiver or obstacles that may interfere with the transmission of electromagnetic waves.
- Choose the installation of the receiver in a vertical position and easily accessible for maintenance operations.
- Avoid that the receiver is subjected to strong vibrations. Use vibration dampers if necessary.
- Always make sure that the value of the supply voltage complies with the rated voltage indicated on the rating plate of the receiver.
- Use multi-pole connectors for the electrical connection of the receiver to the machinery to allow easy removal if required.
- Use cables of suitable section, max. 2.5 mm².
- Connect the Stop circuit making sure that the current circulating therein does not exceed the value of the protection fuse.
- Distribute the common wire to the functions interposing always the Safety relay.
- After installation check that the stop circuit works correctly.
- Check that all limit switched or load limiters are functioning correctly.
- Ensure that all manoeuvres are functioning correctly and are consistent with the symbols placed on the transmitter.

2.4 TRANSMITTING UNIT AT MITO-MINI-915



CONFIGURATIONS WITH 8 BUTTONS

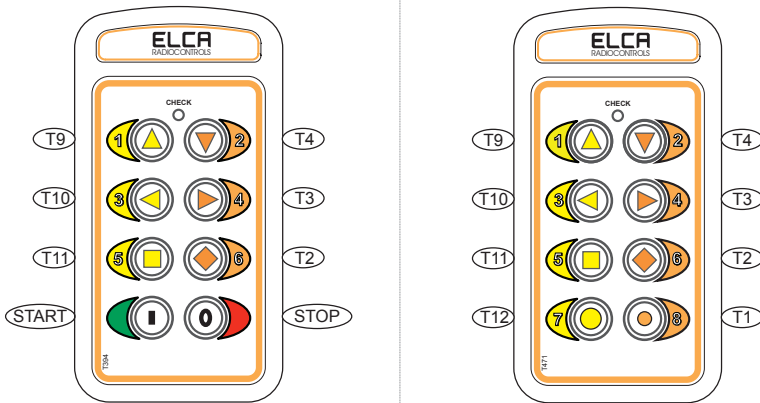

CONFIGURATIONS WITH 4 BUTTONS

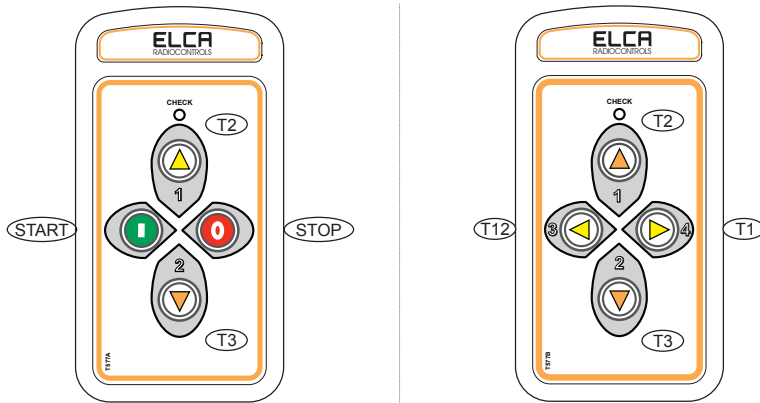

CONTINUOUS Transmission mode (CT)
with Start/Stop buttons

DISCONTINUOUS Transmission mode (DT)
without Start/Stop buttons

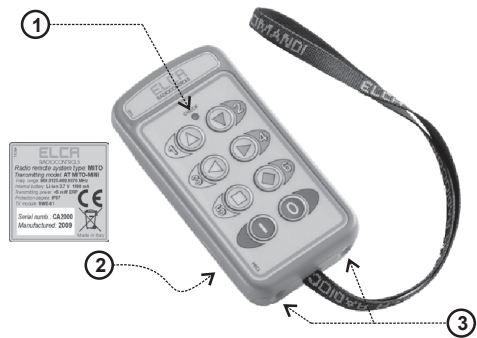

- ① CHECK LIGHT
- ② TRANSMITTING UNIT RATING PLATE (on the back side)
- ③ BATTERY CONTACTS

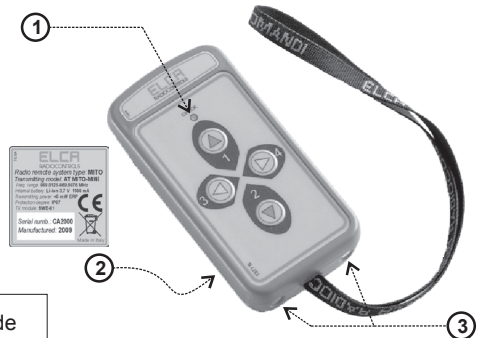

GENERAL FEATURES.

- Battery charge indication.

CONTINUOUS and DISCONTINUOUS Transmission mode (CT and DT).

When the battery is charged, the Check light blinks quickly (1 flash per second).
When battery charge is close to the limit under which safe command transmission is not ensured, the Check light will blink more slowly than usual (approximately 1 flash every 2 seconds) for approximately 10 minutes before the transmitter switches off. The transmitter will not switch on as long as battery charge is not sufficient to ensure safe command transmission. Keeping the battery charged helps to increase its life cycles..

- Two different transmission modes:

CONTINUOUS Transmission mode (CT).	DISCONTINUOUS Transmission mode (DT).
<p>Command T12 (Start) activates radio transmission. Command T1 (Stop) terminates radio transmission and any output commands being sent by the receiver. Transmission may also terminate automatically after 3 or 10 minutes of system inactivity, depending on preset auto-shutdown time (see Paragraph 3.3). Note: The START command involves turning on the transmitter and the activation of the relays T12 and T1 on the receiver. T1 (STOP) remains held until the end of the transmission.</p>	<p>Operating any command when the transmitter is off will activate radio transmission. Commands T12 and T1 lose their Start / Stop significance and operate just like any other command. Transmission terminates after 10 or 180 seconds of system inactivity, depending on preset auto-shutdown time (see Paragraph 3.3).</p>

- Five different auto-shutdown modes:

CONTINUOUS Transmission mode (CT).	DISCONTINUOUS Transmission mode (DT).
- Auto-shutdown after 3 minutes of system inactivity. - Auto-shutdown after 10 minutes of system inactivity. - Auto-shutdown disabled.	- Auto-shutdown after 10 seconds of system inactivity. - Auto-shutdown after 180 seconds of system inactivity

- Start/Stop option (see forward SPECIAL FEATURES):

CONTINUOUS Transmission mode (CT).	DISCONTINUOUS Transmission mode (DT).
Removes the Stop function from command T1. Assigns Start-on-first-pulse function to command T12, activates radio transmission and Stop on second pulse, and then deactivates receiver. Radio transmission can also be terminated by auto-shutdown, depending on preset options	Not available.

- Acknowledged command transmission:

CONTINUOUS and DISCONTINUOUS Transmission mode (CT and DT).
Radio transmission is activated when the Start command is given and remains active only if the transmitter can receive the acknowledge signal sent by the receiver. This function ensures that transmitted command reaches the receiver, as transmitting and receiving units establish permanent communication.

- Automatic working frequency change:

CONTINUOUS and DISCONTINUOUS Transmission mode (CT and DT).
Radio transmission always occurs at low-noise frequencies thanks to the LBT (Listen Before Transmit) technology. This technology enables the system to check that a frequency is free from noise or clear before using it. Whenever communication between transmitter and receiver fails, the system will automatically and seamlessly change working frequency.

- Electronic key:

CONTINUOUS Transmission mode (CT).	DISCONTINUOUS Transmission mode (DT).
A sequence of three commands (Pin Code) to unlock the Start command (T12) can be programmed.	Not available.

- Latching control:

CONTINUOUS Transmission mode (CT).	DISCONTINUOUS Transmission mode (DT).
Each command - except the T12 and T1 commands - can be set to latching mode. A latched command will remain active after the first pulse until the next pulse is given or until the transmitter is switched off.	Not available.

Note:

The programmable functions may be blocked in radio remote controls with special features dedicated exclusively to particular applications or kinds of machines, .

In particular, on a 4 buttons configuration the access to the programming menu is always inhibited.

SOME SPECIAL FEATURES

Features of customised models may differ from those outlined in this manual. Any such particular features are described in annexed documents like control layouts or wiring diagram of the receiver.

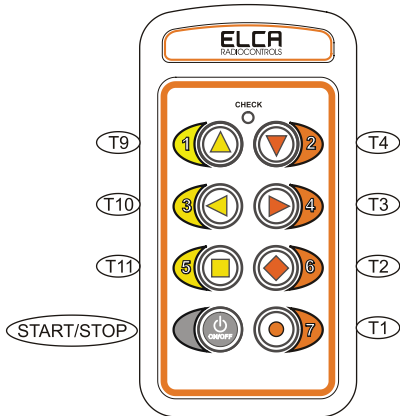

START/STOP Option with 8 buttons configuration

Only in CONTINUOUS Transmission mode (CT).

START / STOP button activates the radio transmission upon the first pressure and switches off on the next.

T1 operates just like any other command.

On the receiver, relay T12 is activated and remains held until the end of the transmission.

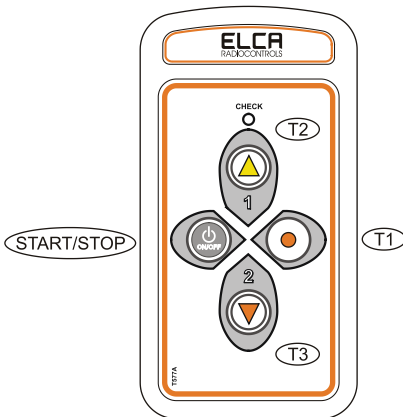

START/STOP Option with 4 buttons configuration

Only in CONTINUOUS Transmission mode (CT).

START / STOP button activates the radio transmission upon the first pressure and switches off on the next.

T1 operates just like any other command.

On the receiver, relay T12 is activated and remains held until the end of the transmission.

2.5 RECEIVING UNIT AR MITO-MINI-915

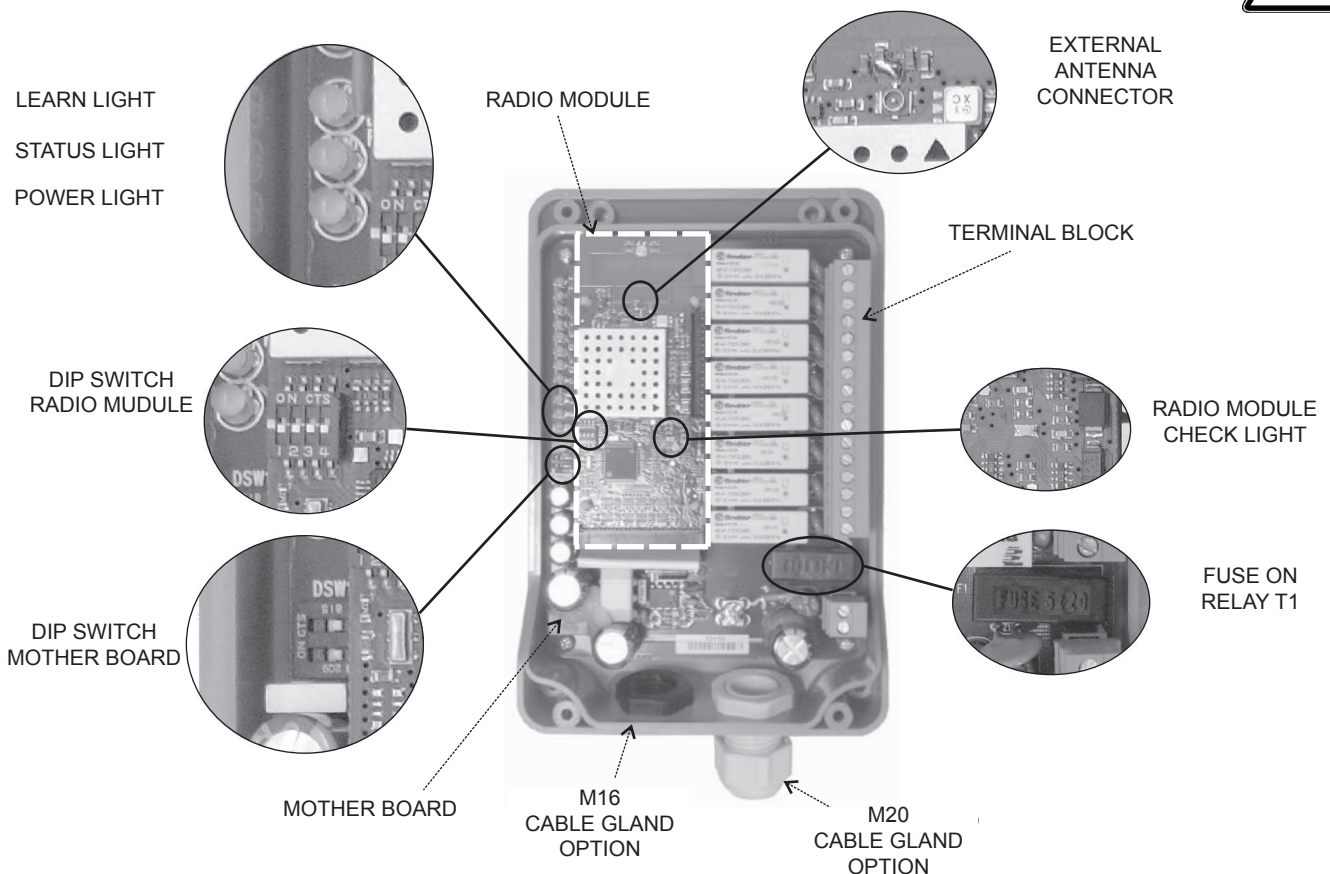

GENERAL FEATURES.

• Self-diagnosis:

CONTINUOUS and DISCONTINUOUS Transmission mode (CT and DT).
The system runs a diagnostic test (CHECK light blinks twice per second) during the first five seconds after receiver power-on. CHECK light blinks once every 2 seconds SYSTEM OK. CHECK light on steady SYSTEM FAILURE.

• Output commands:

CONTINUOUS Transmission mode (CT).	DISCONTINUOUS Transmission mode (DT).
Relay T12 (START) is activated at the press of T12 (START) on the transmitter. Relay T1 (Stop) is active when the radio connection between transmitter and receiver is active. Relay T1 (Stop) is protected by fuse F1 (6.3A). MOTHER BOARD DIP SWITCH: DIP1 OFF - DIP2 OFF.	Relay T12 is activated at the press of T12 on the transmitter. Relay T1 is activated at the press of T1 on the transmitter. Relay T1 is protected by fuse F1 (6.3A). MOTHER BOARD DIP SWITCH: DIP1 ON – DIP2 OFF.

• Indicator lights:

CONTINUOUS and DISCONTINUOUS Transmission mode (CT and DT).
POWER LIGHT indicates the system is powered on. STATUS LIGHT blinks once per second to indicate that radio connection is active. LEARN LIGHT provides indications when in programming mode.

• External antenna option:

CONTINUOUS and DISCONTINUOUS Transmission mode (CT and DT).
Bring the external antenna cable to cable gland M16 which you will have prepared previously. Connect the external antenna to the connector on the radio module; do not force the connection. Tighten the cable gland on the largest diameter cable only.

• Terminal block and wiring.

CONTINUOUS and DISCONTINUOUS Transmission mode (CT and DT).
Maximum useful cross-section area 2.5 sq mm. For wiring connections, follow the mother board layout and the wiring examples provided in ANNEX A and any documents attached to this manual.

2.6 STORING ACCESS CODES



In order to associate a transmitter to receiver, the transmitter access code needs to be stored in the receiver memory. The access code is a unique code set at the factory that prevents the receiver installed on the machinery from responding to any unauthorised transmitters. When several transmitters are registered in a receiver's memory, the receiver will handle transmitters on a first-come-first-served basis and the current transmitter will have exclusive access to the receiver until transmission is terminated. Up to 20 access codes can be stored.

Learn mode:

The learn mode allows you to associate one or more new transmitters to the receiver.

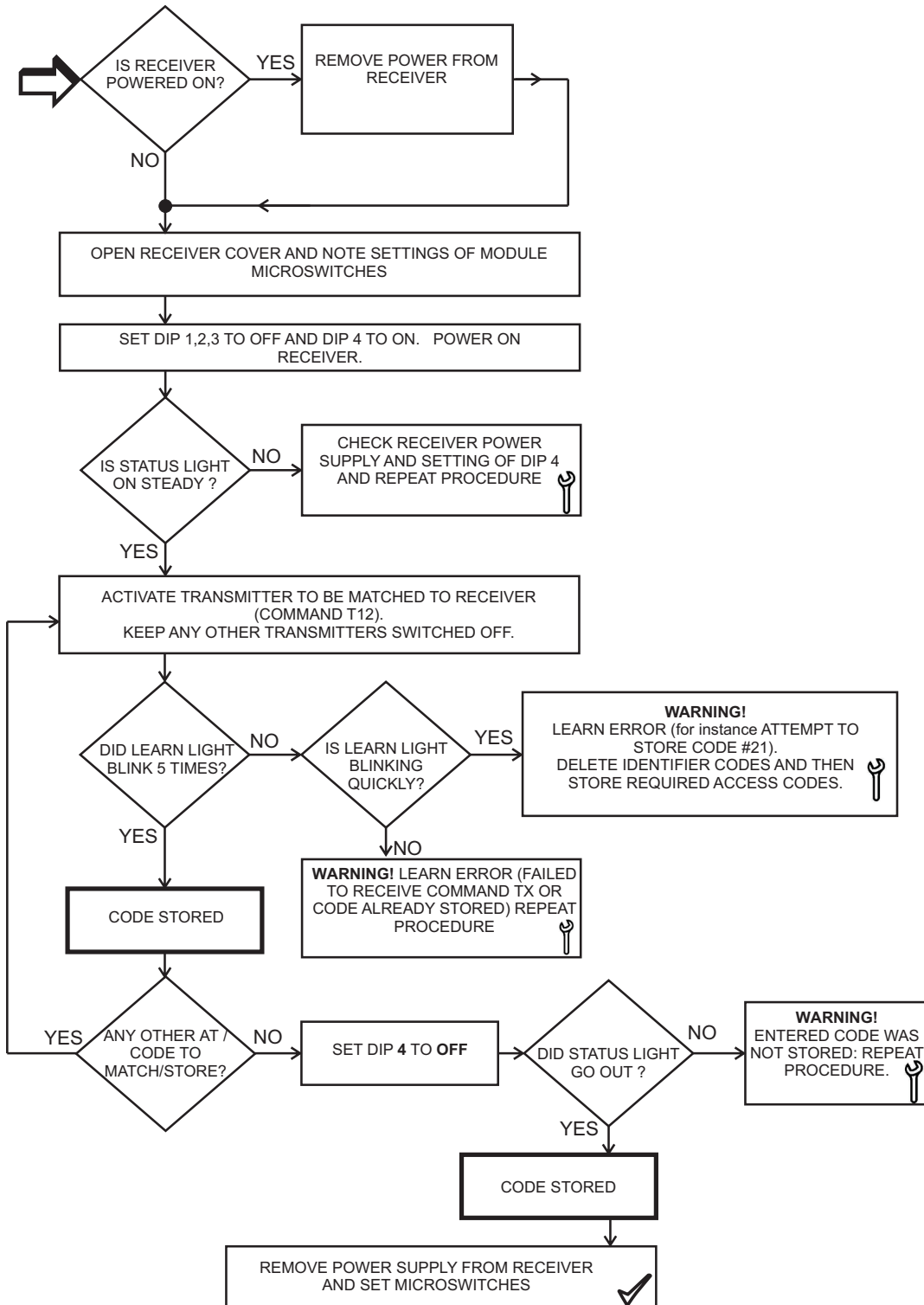

Delete mode:

The delete mode removes from the receiver memory ALL access codes of transmitters associated.

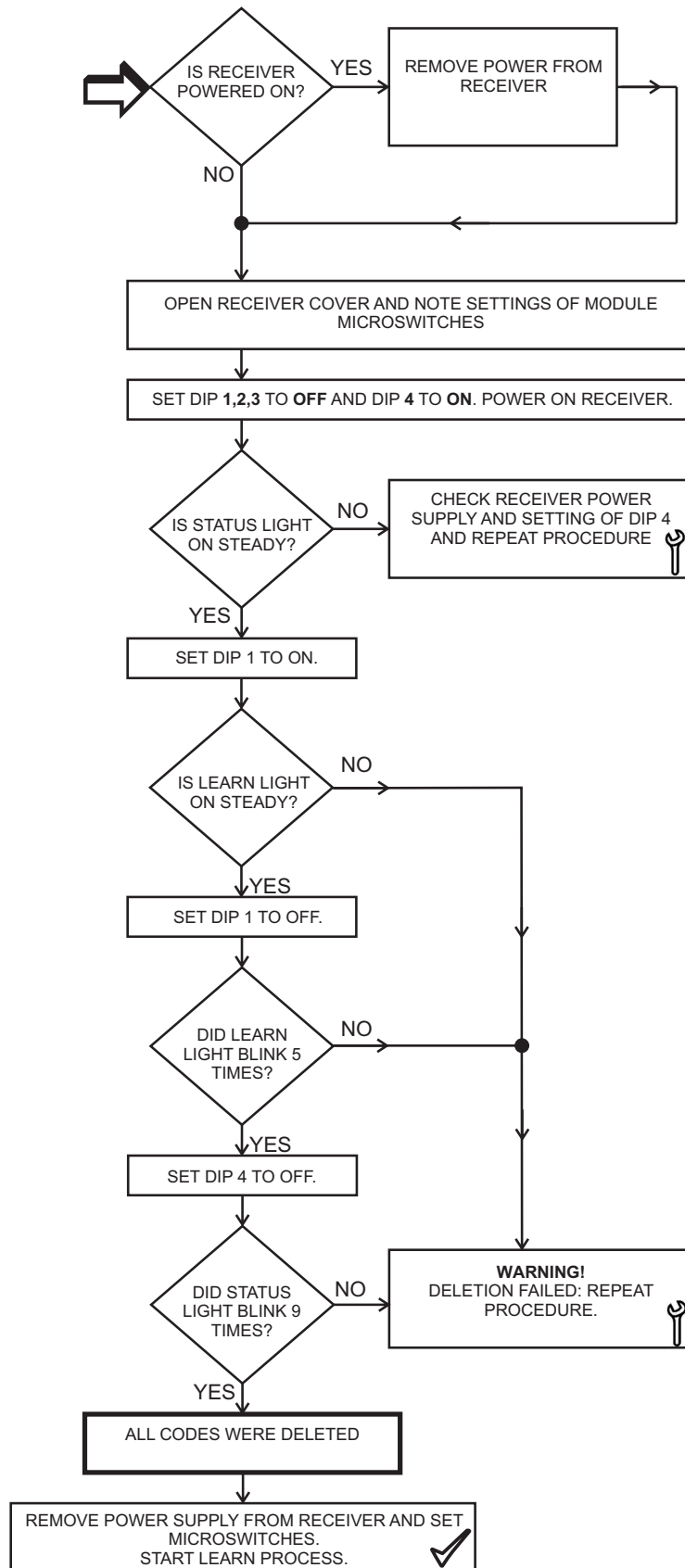

Note¹: If a transmitter becomes unserviceable and needs to be replaced, there is no need to delete existing access codes unless all available access codes have been used.

Note²: If no access codes are stored in the receiver, the STATUS light blinks 8 times quickly, blinks once slowly, stays off for 3-4 seconds and then repeats the sequence.

2.7 INFORMATION FOR MAINTENANCE



Please remember that the receiving unit should be disconnected from power supply and the transmitting unit should be powered off during maintenance procedures.

The Radio Remote Control System requires minimal maintenance, however, following these few simple tips will help keep it in good working order.

TRANSMITTING UNIT

Periodically

- clean unit with a brush and wet cloth; avoid using alcohol, solvents or detergents
- ensure the battery charge contacts are clean
- check housing and rubber parts for damage

In addition, DO NOT:

- expose unit to jets of water or heavy rain
- leave unit exposed to sun radiation
- clean unit with jets of water or blow with compressed air
- immerse in water
- Before storing the system away for long periods, fully charge the battery



RECEIVING UNIT

Periodically

- clean unit with a brush and wet cloth; avoid using alcohol, solvents or detergents;
- check housing and rubber parts for damage.
- check any connectors and/or cable glands for proper tightening.

In addition, DO NOT:

- clean unit with jets of water or blow with compressed air.



2.8 INFORMATION FOR THE PROPER INSTALLATION OF THE RADIO REMOTE CONTROL SYSTEM



System must be installed and serviced by qualified and trained personnel.

Proper installation of the radio remote control is critical to ensuring proper operation and ease of maintenance.

Following are a few recommendations to be followed before and after installation:

- Perform a careful risk analysis to determine whether the machine is suitable for working in conjunction with a radio remote control and identify any residual risks. The manufacturer of the machine and / or the installer of radio remote control is responsible for this analysis. The ELCA Company can not be held responsible for the operation of its system on applications where the risk analysis was not carried out properly.
- Be aware that in case of interruption of the radio link for active stop, auto power off, low battery, power failure of the receiver, radio range exceeded, interference, etc.. all the outputs of the receiver are turned off and it is no longer possible to control the equipment until a further restart of the radio remote control. Carefully consider whether this can be a danger.
- To obtain the maximum range, install the receiving unit between 2 and 10 metres above the ground and where there are no obstacles between transmitter and receiver;
- install the receiving unit housing within easy reach to ensure safe access by repair or maintenance technicians;
- use multi-pin connectors to connect receiver to machine so as to facilitate replacement in the event of a failure;
- the place selected for receiving unit installation should be free from vibration: where this is not possible, use vibration dampers;
- do not install the receiving unit inside metal casings that could affect its operation;
- ensure that there are no obstacles that could affect transmission between transmitting and receiving units: where any obstacles cannot be eliminated, use the optional external antenna (special kit available) to ensure proper radio communication;
- use cables with suitable cross-section area for wiring connections;
- be sure to connect power supply to the proper terminal;
- check for proper operation after installation.

2.9 WARRANTY



The ELCA Radio Remote Control System MITO is covered by a 24-month warranty starting from date of purchase as evidenced by the way bill, that must also state the serial number of the Radio Remote Control System.

Warranty covers defects of manufacture of the radio remote control system and its components, when such defects have been determined to exist at ELCA's sole discretion.

User shall arrange the delivery to / collection from ELCA authorised service centres and defective parts shall be replaced at no additional charge.

In the event of on-site servicing/repair, travel and personnel expenses shall be charged to the user, whereas the replacement of any defective parts shall be free of charge.

Servicing/repair by unauthorised persons, improper use or improper installation shall make the warranty null and void.

Warranty does not cover transport damage or loss.

ELCA shall not be held liable for damage to property or persons.

ELCA shall not be liable for machine down time, and it is the user's responsibility to provide manual or wire control for each machine.

Any disputes shall be submitted to the Court of Bassano del Grappa (Vicenza, Italy).

2.10 DISPOSAL INFORMATION



The radio remote control must be delivered to separate collection at end of life.

DISPOSAL OF BATTERIES, Directive 2006/66/EC and subsequent amendments.

Batteries may release toxic substances harmful to humans, animals and plants and contaminate the environment. They should be not disposed of with municipal solid waste but delivered to authorised collection centres for battery recycling and treatment.

Users' contribution to collect and recycle batteries is critical to minimising the potential impact of the contaminants used in these components on the environment and human health.

The European Union has set up different battery collection and recycling systems. For information on the method adopted in your area, contact your local authorities.

The crossed-out wheeled bin symbol on the batteries means that batteries must be disposed of separately from household waste in compliance with Directive 2006/66/EC and subsequent amendments and with local regulations.



3. PROGRAMMABLE FUNCTIONS



3.1 ACCESS TO PROGRAMMING MODE

Outlined below are certain programmable functions that can be set by the user ONLY in certain versions. Only the frequency range programming is always available.

WARNING!

Be careful when programming functions other than the original ones in customised radio remote controls or units that are already installed on a machine, as the new functions might lead to abnormal operation of the machine. We advise against programming or making programming tests on radio remote controls that are already installed on a machine.

In every MITO-MINI-915 with 4 buttons and in some MITO-MINI-915 with 8 buttons customized for specific applications, access to programming mode is disabled. The programmable functions, if necessary, are preset by the manufacturer.

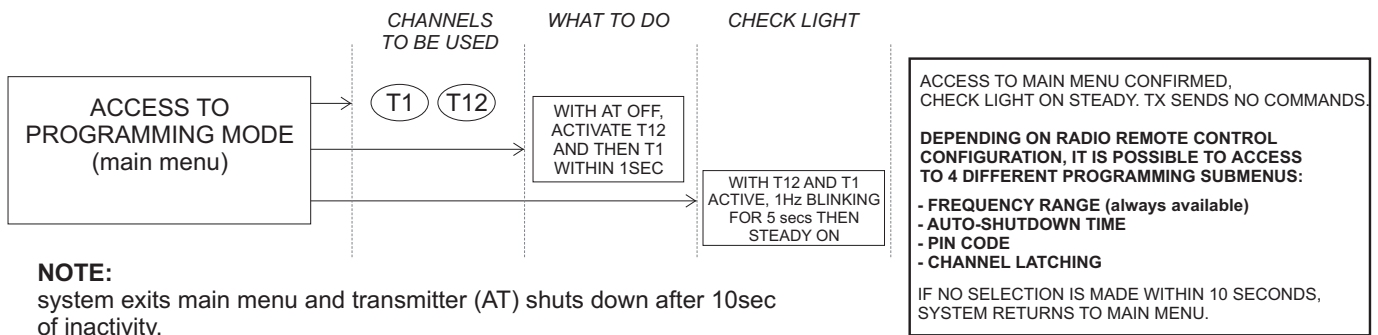

3.2 FREQUENCY RANGE PROGRAMMING

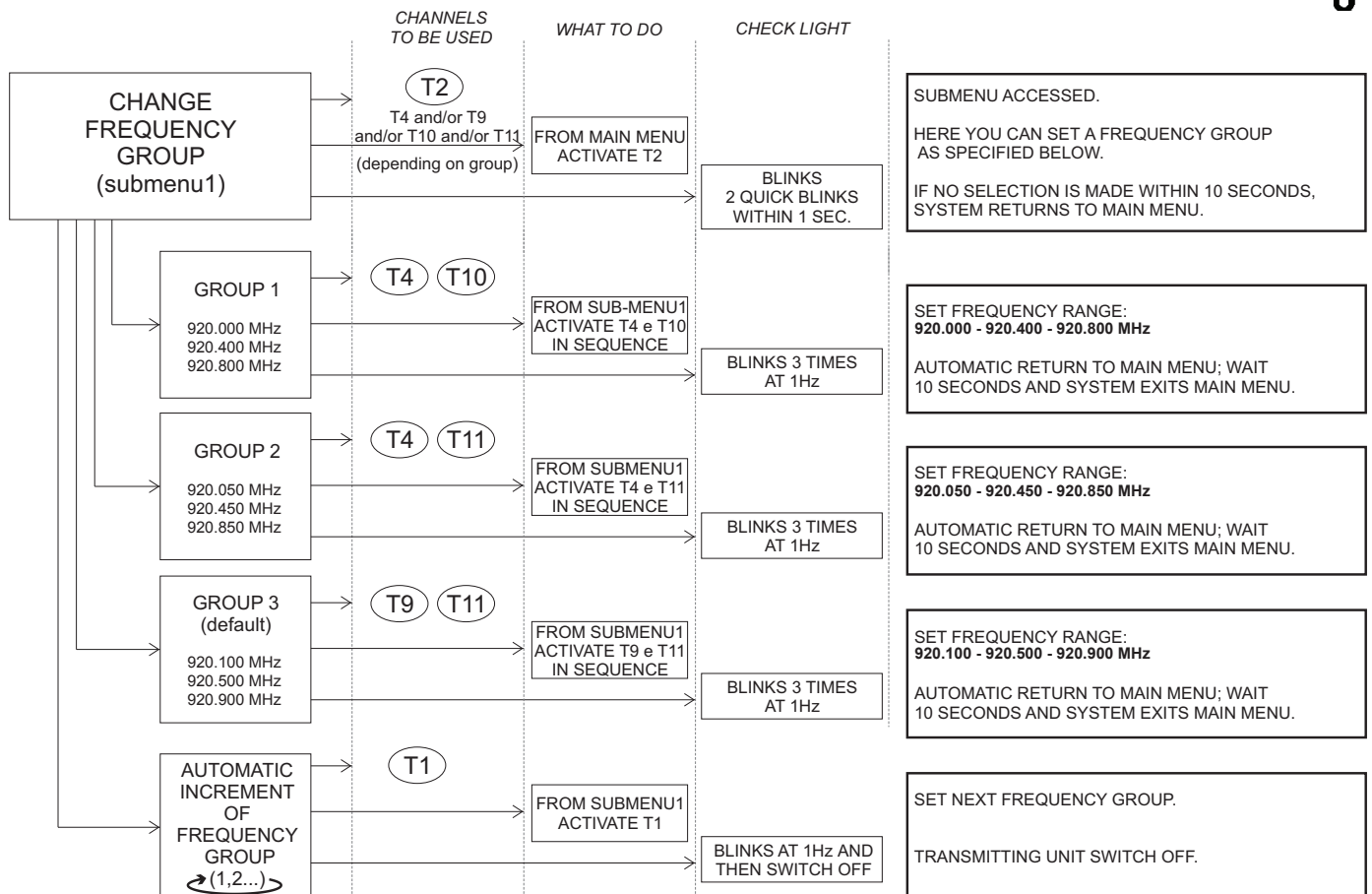

EXAMPLE: programming frequency group 2

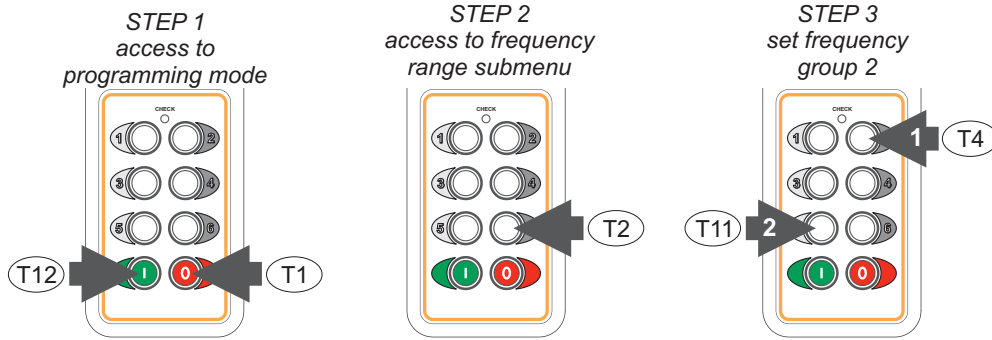

3.3 AUTO-SHUTDOWN TIME PROGRAMMING



ENGLISH

	CHANNELS TO BE USED	WHAT TO DO	CHECK LIGHT	
AUTO-SHUTDOWN TIME (submenu2)	T3 and T2 or T3 or T4 or T9 or T10 or T11 (depending on set time)	FROM MAIN MENU ACTIVATE T3	BLINKS 2 QUICK BLINKS WITHIN 1 SEC.	SUBMENU ACCESSED. HERE YOU CAN SET 6 DIFFERENT AUTO-SHUTDOWN TIMES AS SPECIFIED BELOW. IF NO SELECTION IS MADE WITHIN 10 SECONDS, SYSTEM RETURNS TO MAIN MENU.
START/STOP Option FOR CT ONLY (1)	T2	FROM SUBMENU2 ACTIVATE T2	BLINKS 3 TIMES AT 1Hz	START/STOP OPTION LETS YOU START /STOP TRANSMISSION FROM BUTTON T12. T12 GIVES START COMMAND ON FIRST PULSE AND STOP COMMAND ON SECOND PULSE. THIS OPTION IS NOT COMPATIBLE WITH DISCONTINUED TRANSMISSION MODE. AUTOMATIC RETURN TO MAIN MENU; WAIT 10 SECONDS AND SYSTEM EXITS MAIN MENU.
180 sec FOR DT ONLY (2)	T3	FROM SUBMENU2 ACTIVATE T3	BLINKS 3 TIMES AT 1Hz	DISCONTINUOUS TRANSMISSION WITH 180-SEC AUTO-SHUTDOWN. ANY CHANNEL ACTIVATES TRANSMISSION, TRANSMISSION TERMINATES AFTER 180 SECS OF INACTIVITY. AUTOMATIC RETURN TO MAIN MENU; WAIT 10 SECONDS AND SYSTEM EXITS MAIN MENU.
10sec FOR DT ONLY (2)	T4	FROM SUBMENU2 ACTIVATE T4	BLINKS 3 TIMES AT 1Hz	DISCONTINUOUS TRANSMISSION WITH 10-SEC AUTO-SHUTDOWN, ANY CHANNEL ACTIVATES TRANSMISSION, TRANSMISSION TERMINATES AFTER 10 SECS OF INACTIVITY. AUTOMATIC RETURN TO MAIN MENU; WAIT 10 SECONDS AND SYSTEM EXITS MAIN MENU.
3min FOR CT ONLY (3)	T9	FROM SUBMENU2 ACTIVATE T9	BLINKS 3 TIMES AT 1Hz	AUTO-SHUTDOWN SET TO 3 MINUTES: START CHANNEL INITIATES RADIO CONNECTION, CONNECTION TERMINATES WHEN STOP IS ACTIVATED OR AFTER 3 MINUTES OF INACTIVITY. AUTOMATIC RETURN TO MAIN MENU; WAIT 10 SECONDS AND SYSTEM EXITS MAIN MENU.
10min (default) FOR CT ONLY (3)	T10	FROM SUBMENU2 ACTIVATE T10	BLINKS 3 TIMES AT 1Hz	AUTO-SHUTDOWN SET TO 10 MINUTES: START CHANNEL INITIATES RADIO CONNECTION, CONNECTION TERMINATES WHEN STOP IS ACTIVATED OR AFTER 10 MINUTES OF INACTIVITY. AUTOMATIC RETURN TO MAIN MENU; WAIT 10 SECONDS AND SYSTEM EXITS MAIN MENU.
Disabling auto-shutdown FOR CT ONLY (3)	T11	FROM SUBMENU2 ACTIVATE T11	BLINKS 3 TIMES AT 1Hz	AUTO-SHUTDOWN DISABLED: START CHANNEL INITIATES RADIO CONNECTION, CONNECTION TERMINATES WHEN STOP IS ACTIVATED. AUTOMATIC RETURN TO MAIN MENU; WAIT 10 SECONDS AND SYSTEM EXITS MAIN MENU.

NOTE:

(1) **Continuous** Transmission (CT), with "START/STOP Option": set **mother board microswitches** as follows: dip1=Off and dip2=Off;

(2) **Discontinuous** Transmission (DT), channels T1 and T12 serve as common function commands: set **mother board microswitches** as follows: dip1=On and dip2=Off;

(3) **Continuous** Transmission (CT): set **mother board microswitches** as follows: dip1=Off and dip2=Off;

[WARNING] To switch from Continuous Transmission (CT) mode to Discontinuous Transmission (DT) mode and vice versa you must setup the motherboard: contact technical support.

EXAMPLE: Disabling auto-shutdown

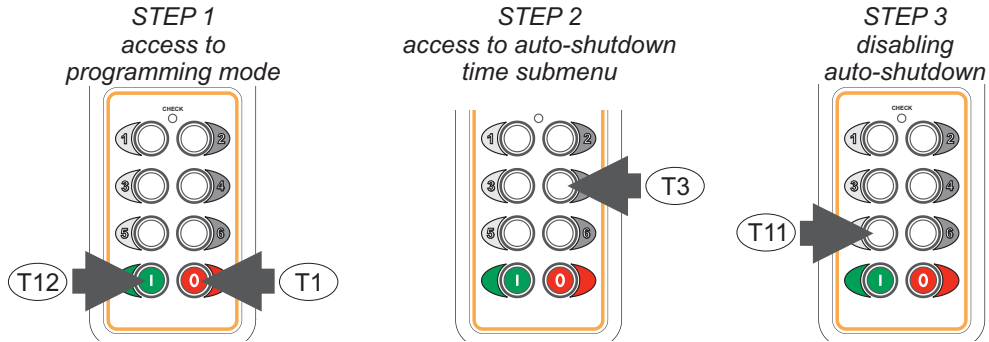

3.4 PIN CODE PROGRAMMING

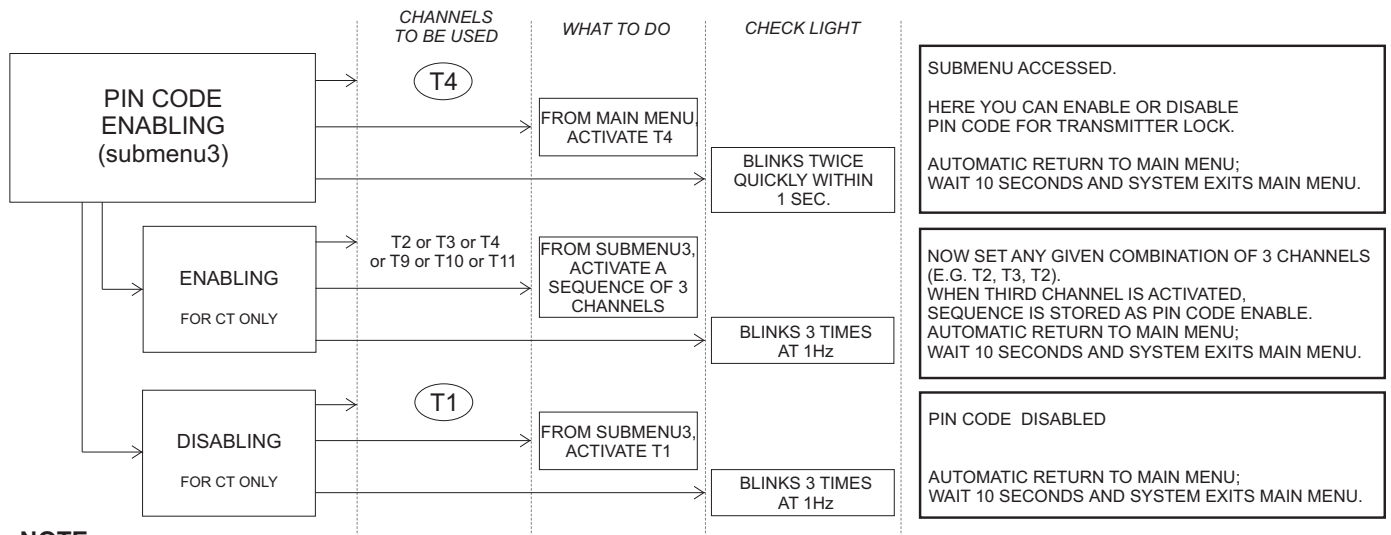

NOTE

- This function may only be programmed in continuous trasmission mode (CT);
- no default pin code is set at the factory;
- if you forget the pin code unlock sequence, you will need to programme a new sequence or disable pin code lock before you can use the transmitter.

EXAMPLE: pin code lock setting T9-T10-T11

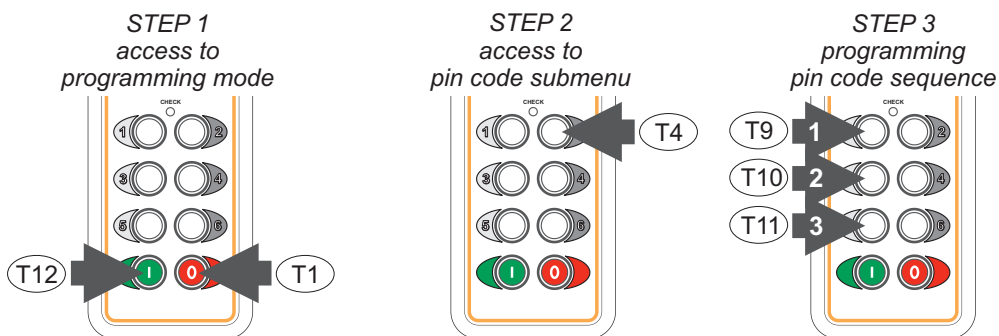



3.5 LATCHED CONTROL PROGRAMMING

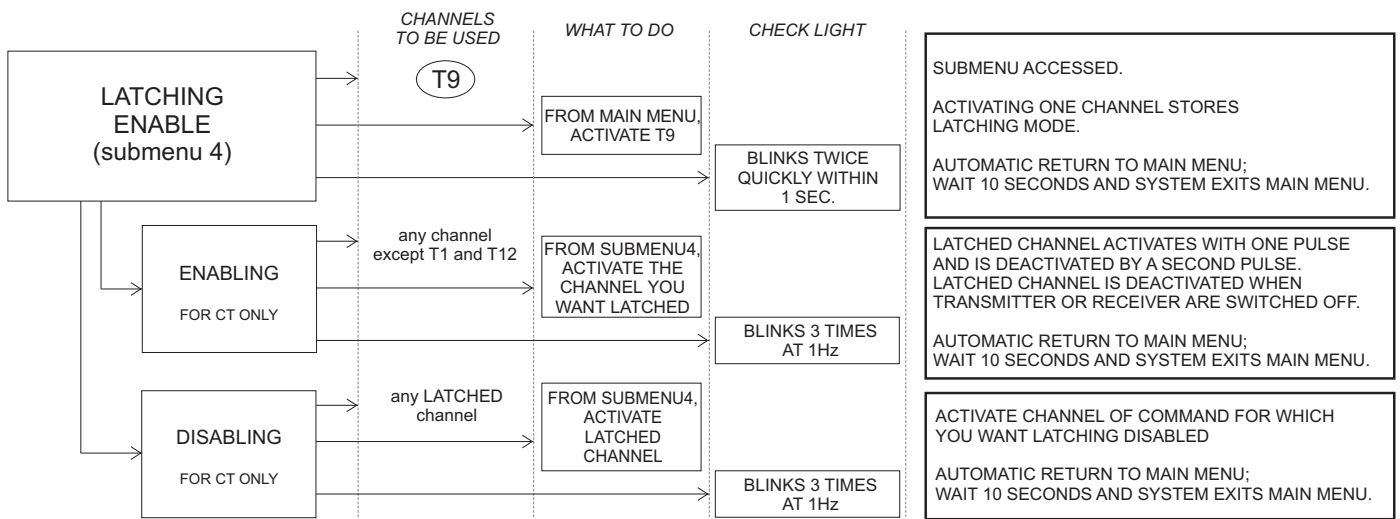

NOTE

- Latching can be programmed for any command except Start(T12) and Stop(T1), only in "START/STOP option" mode can be programmed also for command T1;
- latching may only be set in continuous trasmission mode (CT);
- on standard radio remote controls, no channel is set to latching mode at the factory; latching must be enabled by user.

EXAMPLE: enabling latching command T11

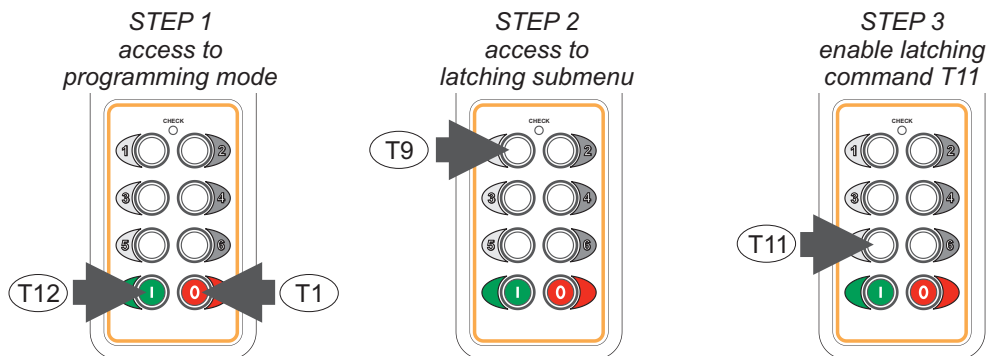

4. BATTERY CHARGER



4.1 OPERATING INSTRUCTIONS

The battery should be charged at an ambient temperature between +0° C and +45° C, avoiding power supply failures during the charging process.

Connect the power supply unit supplied with the battery charger by pushing the plug into the receptacle on battery charger bottom side.

Connect the power supply unit to the power outlet. The GREEN light turns on.

Place the transmitter onto the battery charger and push down until transmitter clicks into place. The charging process begins and light changes to RED color.

When the charging process is terminated the light turn GREEN

Placing the transmitter onto the battery charger terminates the radio connection with the receiver, if still active.

NOTE 1:

The charging process will be interrupted outside the allowed temperature range (over 45° C or below 0° C) to protect the battery. This is indicated by the GREEN light on. The charging process is resumed as soon as temperature is back within the allowed range.

NOTE 2:

Ensure that the battery is fully charged before storing away the radio remote control for long periods of time. Leaving the unit unused for long periods with a low battery may significantly shorten product life..

5. TROUBLESHOOTING



5.1 TYPE OF TROUBLE

TROUBLE	POSSIBLE CAUSE	SUGGESTED REMEDY
<p>RADIO CONNECTION FAILURE:</p> <p>In continuous transmission mode, pressing Start does not activate radio connection. (Check light off)</p> <p>In discontinuous transmission mode operating any control will not cause Check light to blink or activate any command.</p>	BATTERY FLAT	Recharge the batteries (see Par. 5.4)
	TRANSMITTER - RECEIVER NOT MATCHED	Access code storage procedure (see Paragraph 2.6). For new systems, ensure serial numbers are correct.
	SYSTEM OUTSIDE OPERATING RANGE	Ensure that operating distance is within the allowed range (see Chap. 6) and that system has been installed correctly (see Paragraph 2.8)
	SYSTEM IMPROPERLY INSTALLED	Check system for proper installation (receiving unit position, metal obstacles,...) (see Paragraph 2.8)
	RECEIVER OFF OR NOT WORKING	Receiver shutdown will cause the transmitter to switch off as well. Power on the receiver (see Paragraph 5.3)
	PIN CODE ACTIVE	Unlock the PIN CODE (see Paragraph 3.4)
	USEFUL FREQUENCIES DISTURBED	Ensure there are no other similar systems or sources of noise such as radio bridges or transmitters. Check light on steady with Start command maintained after 1 or 2 seconds. (see Paragraph 5.2)
For any causes other than those listed above	(see Paragraph 5.2)	

<p>REPEATED RADIO CONNECTION FAILURES.</p> <p>In continuous transmission mode, the transmitter shuts down and radio connection can only be restored using the Start command.</p> <p>In discontinuous transmission mode, the transmitter shuts down before auto-shutdown kicks in.</p>	FREQUENCIES DISTURBED	Change frequency (see Paragraph 3.2)
	RECEIVER OFF	Receiver shutdown will cause the transmitter to switch off as well.
	BATTERIES FLAT	Check battery charge level (see Par. 5.4)
	EXTERNAL ANTENNA (if fitted)	Check for correct position and connection.
	SYSTEM IMPROPERLY INSTALLED	Check system for proper installation (receiving unit position, metal obstacles,...). (see Paragraph 2.9)
	For any causes other than those listed above	(see Paragraph 5.2)

<p>ONE OR MORE CONTROLS FAIL TO ACTUATE THE CORRESPONDING MOVEMENT.</p>	DAMAGED FUSE	Check the fuse inside the receiving unit
	COMMAND TRANSMISSION FAILED	Ensure that the receiver light corresponding to the command actuated from the transmitter turns on. (see Paragraph 5.3)
	WRONG WIRING CONNECTION	Check wiring in receiving unit.



5.2 FUNCTIONAL TESTING OF TRANSMITTING UNIT

Follow the diagram below (starting from the top left corner) to solve or identify the problem.

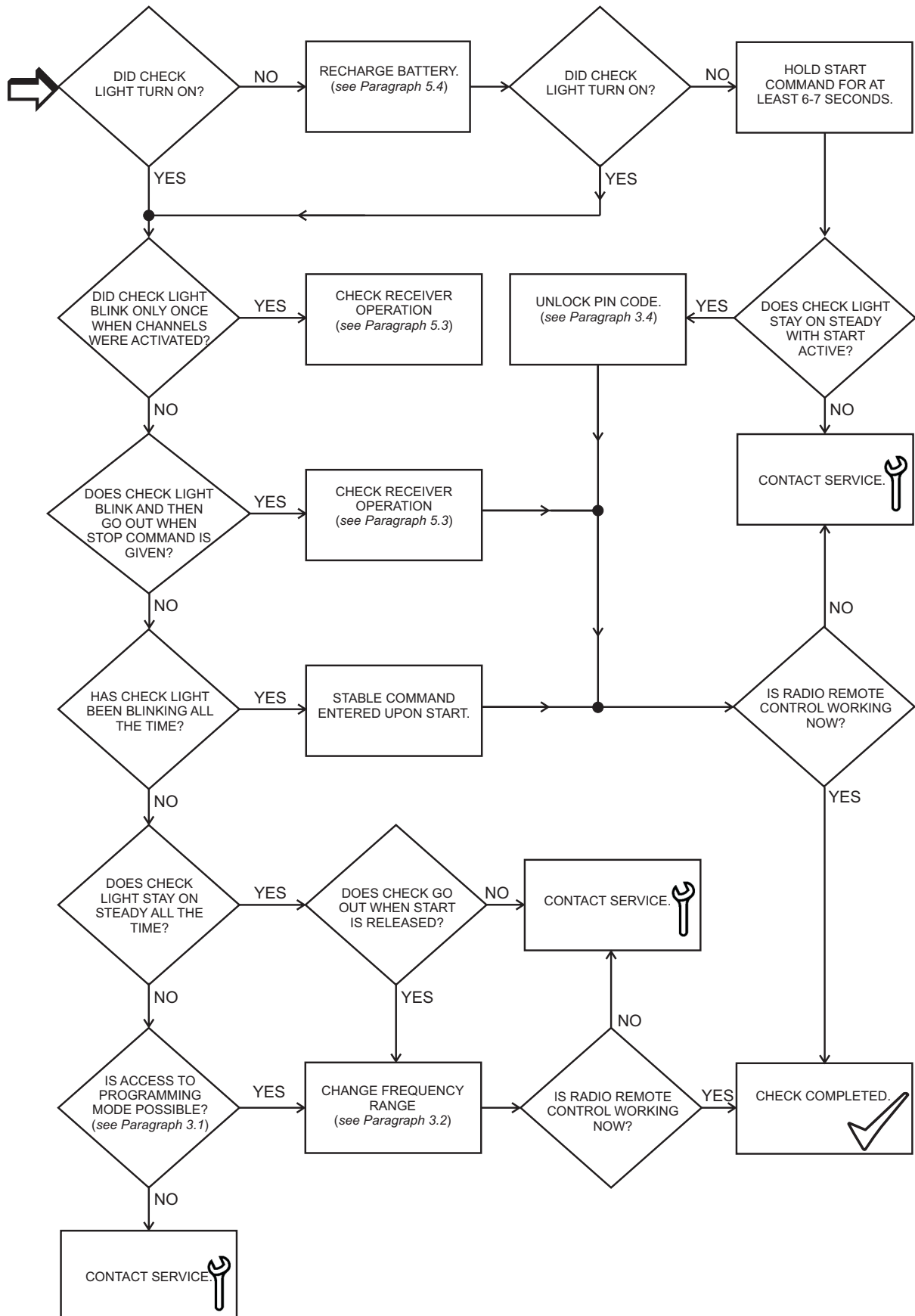



5.3 FUNCTIONAL TESTING OF RECEIVING UNIT

Follow the diagram below (starting from the top left corner) to solve or identify the problem.

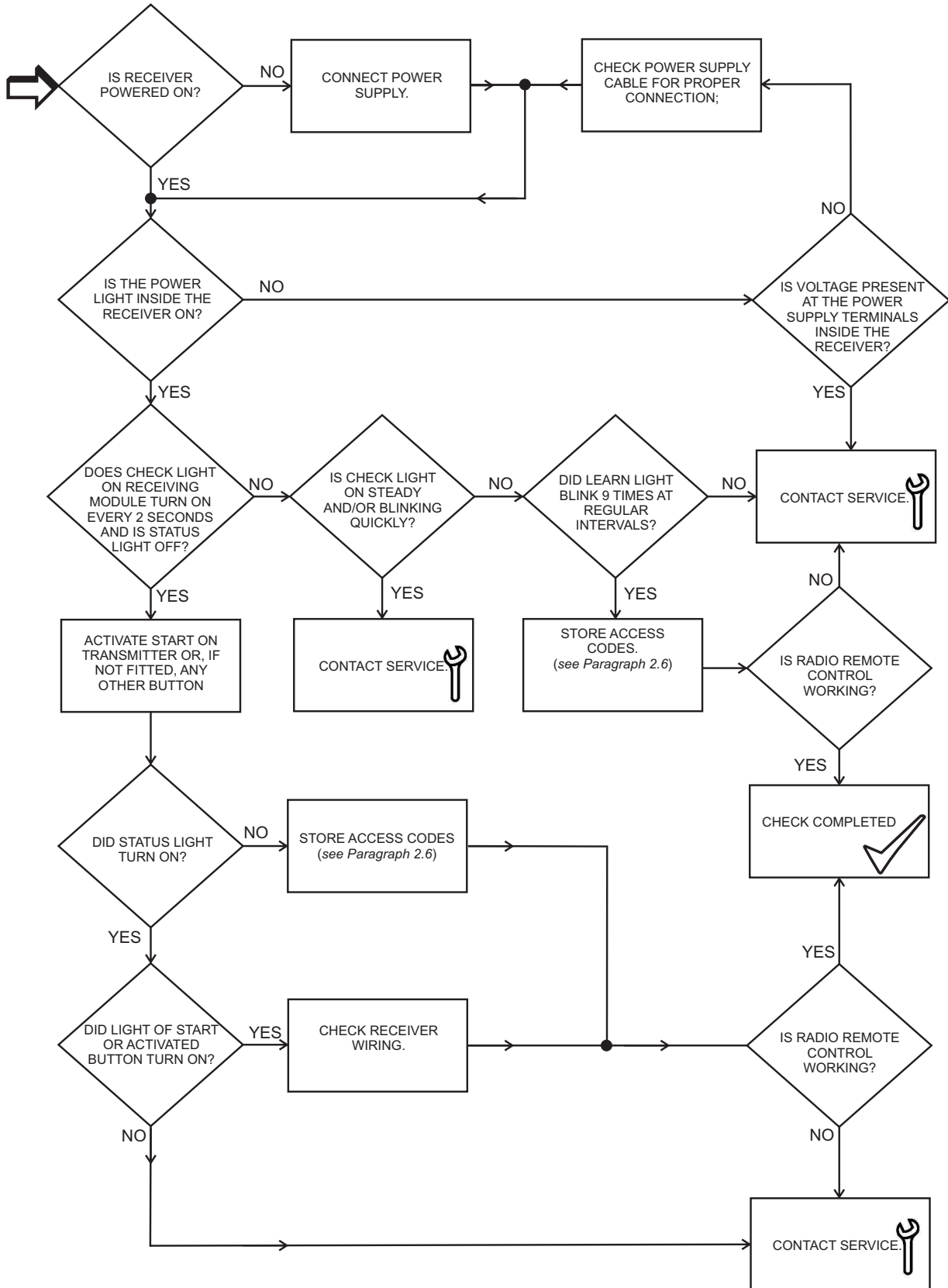



5.4 FUNCTIONAL TESTING OF CHARGING CYCLE

Follow the diagram below (starting from the top left corner) to solve or identify the problem.

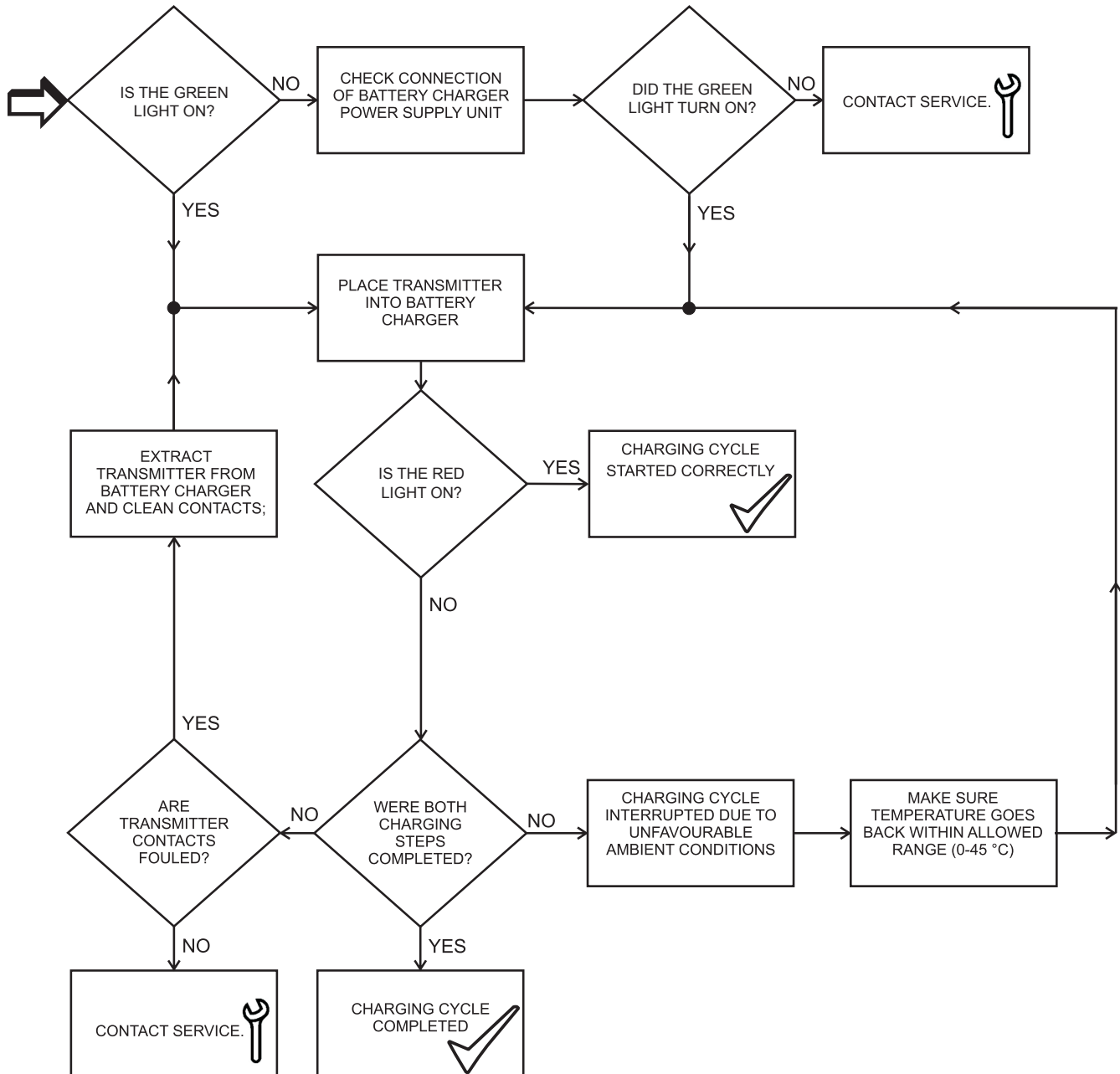

6. TECHNICAL FEATURES

6.1 GENERAL



Manufacturer	ELCA S.r.l.
Radio Remote Control System type	MITO
ISM band working frequency	920.000 - 921.150 MHz
Modulation type	GFSK
Hamming distance	≥10
Working temperature	from -20 °C to +55 °C
Storage and transportation temperature	from -20 °C to +55 °C
Operating range	150 m
Time to passive STOP	< 1 s

6.2 FEATURES OF TRANSMITTING UNIT



Model	AT MITO-MINI-915
Transmitter/coder radio module	SWE-U
Antenna	incorporated
Power supply	Lithium polymer battery pack 3,7 V 1100 mAh
Current draw	< 25 mA
Absorbed power	< 0,1 W
RF effective radiated power	< 3 mW ERP
Low battery warning voltage	3,4 V
Shutdown voltage	3,0 V
Operation time with charged battery at 20 °C	approximately 50 hours
Low battery warning time before shutdown	approximately 10 minutes
Protection degree	IP67
Dimensions	113x60x26 mm
Weight	100 g

6.3 FEATURES OF RECEIVING UNIT



Model	AR MITO-MINI-915
Transmitter/coder radio module	SWE-U
Antenna	Incorporated or dedicated external
Power supply	9-30 V==
.....	12-24 V~ 50/60Hz
Consumption	< 5 W
Relay outputs with NO contacts	max 10 commands
Maximum contact voltage	230 V ~
Fuse on Stop relay	F1= T 6.3A L 250V
Maximum output current	10 A in AC1, 10 A in DC1 a 30V
Protection degree	IP67
Dimensions	165x107x50 mm
Weight	450 g

WARNING: In case on the relay contacts you use dangerous voltages, higher than 42.4 Volt AC or higher than 60 Volt DC, you need to consider also power supply circuit as connected to dangerous voltages. In this case it is necessary to provide a power circuit dedicated to the feeding of the receiver with suitable connections as regards the existing dangerous voltage.

In case of dangerous voltages inside the receiver, it is not allowed to use the external antenna.

6.4 FEATURES OF BATTERY CHARGER MITO-BC



Model.....	MITO-BC
Supply voltage	5.0 V ==
Rated power	< 3 W
Rated output voltage	4.2 V ==
Rated output current.....	450 mA
Recharging time	≤ 4 hours
Working temperature	from -20 °C to +55 °C
Protection degree	IP40
Dimensions	130x75x65 mm
Weight	130 g

AC power supply unit:

Power supply unit supply voltage	80-250 V ~ 50/60Hz
Output voltage	5,0 V 1 A
Rated power	5 W

DC power supply unit for lighter outlet:

Power supply unit supply voltage	9 - 30 V ==
Output voltage	5,0 V 1 A
Rated power	5 W



ANNEX A

MOTHER CARD LAYOUT 8 RELAYS LAYOUT SCHEDA BASE 8 RELE'

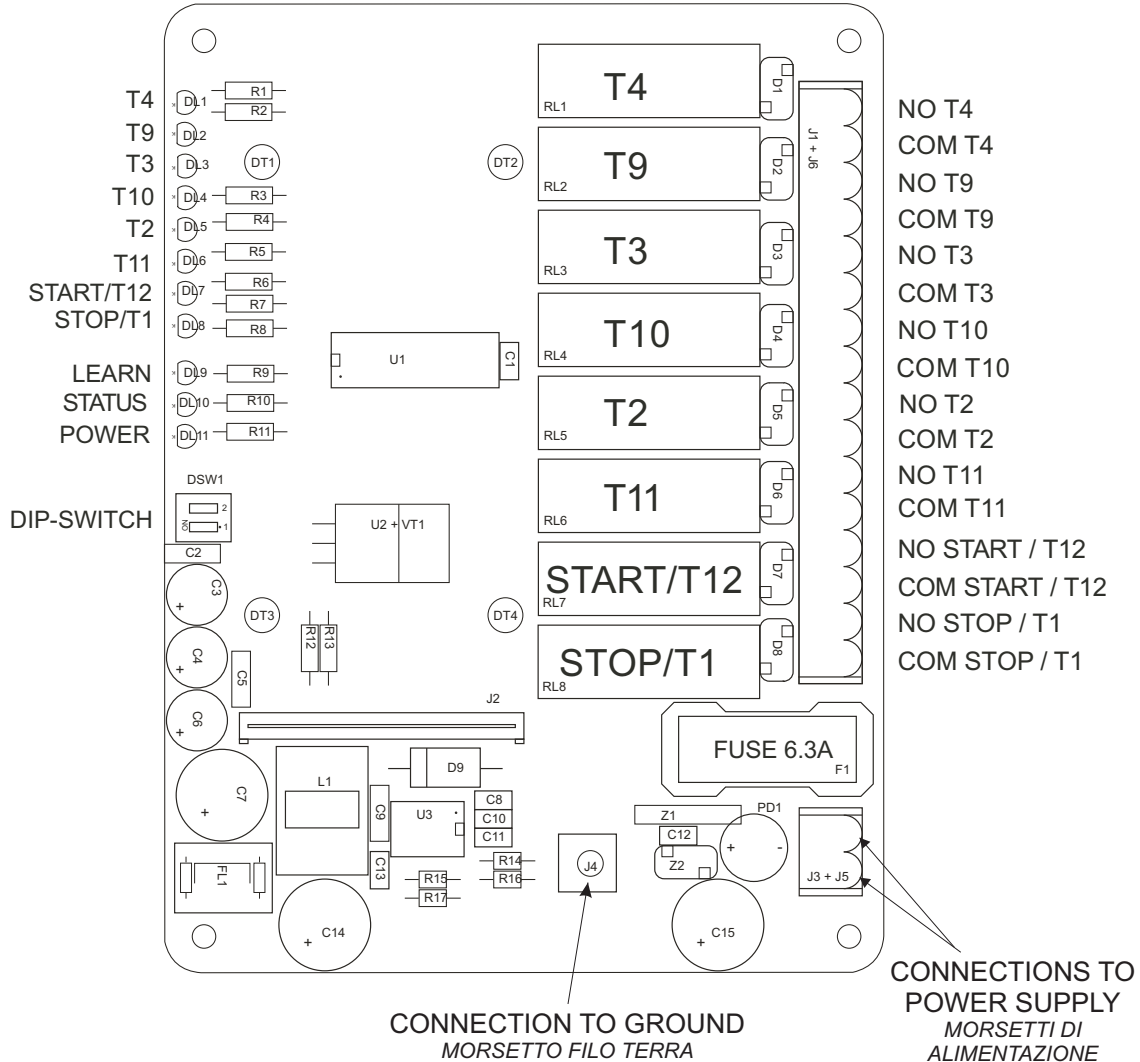

ENGLISH

On "START/STOP Option," mode, relay T12 is activated by pressure of START/STOP button and remains held until the radio connection between transmitter and receiver is active, instead relay T1 operates just like any other command.

Nella configurazione "Opzione START/STOP," il relè T12 si attiva alla pressione del pulsante START/STOP e rimane ritenuto fino a che il collegamento radio tra trasmettitore e ricevitore è attivo, mentre il relè T1 si comporta come un normale comando.

Vdc POWER SUPPLY WIRING DIAGRAM
CABLAGGIO CON ALIMENTAZIONE IN CORRENTE CONTINUA

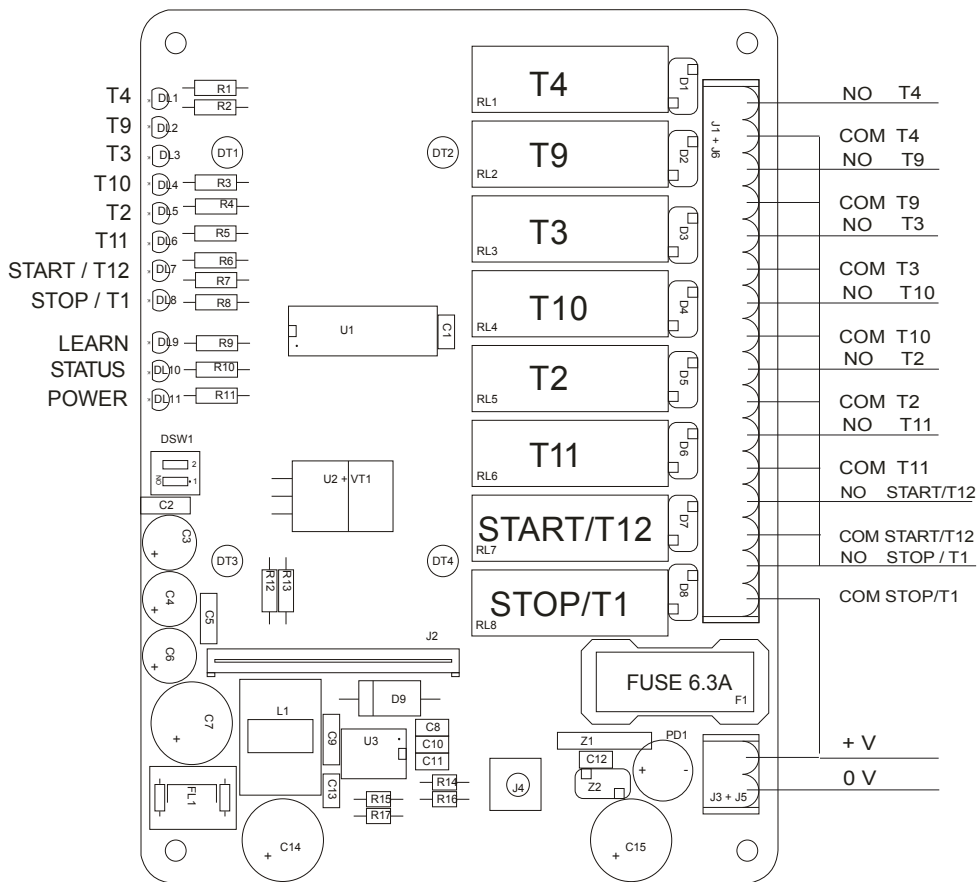

Vac POWER SUPPLY WIRING DIAGRAM
CABLAGGIO CON ALIMENTAZIONE IN CORRENTE ALTERNATA

