

# BRAVO

**ELCA**  
RADIOCONTROLS

# BRAVO-FUNK+ 915

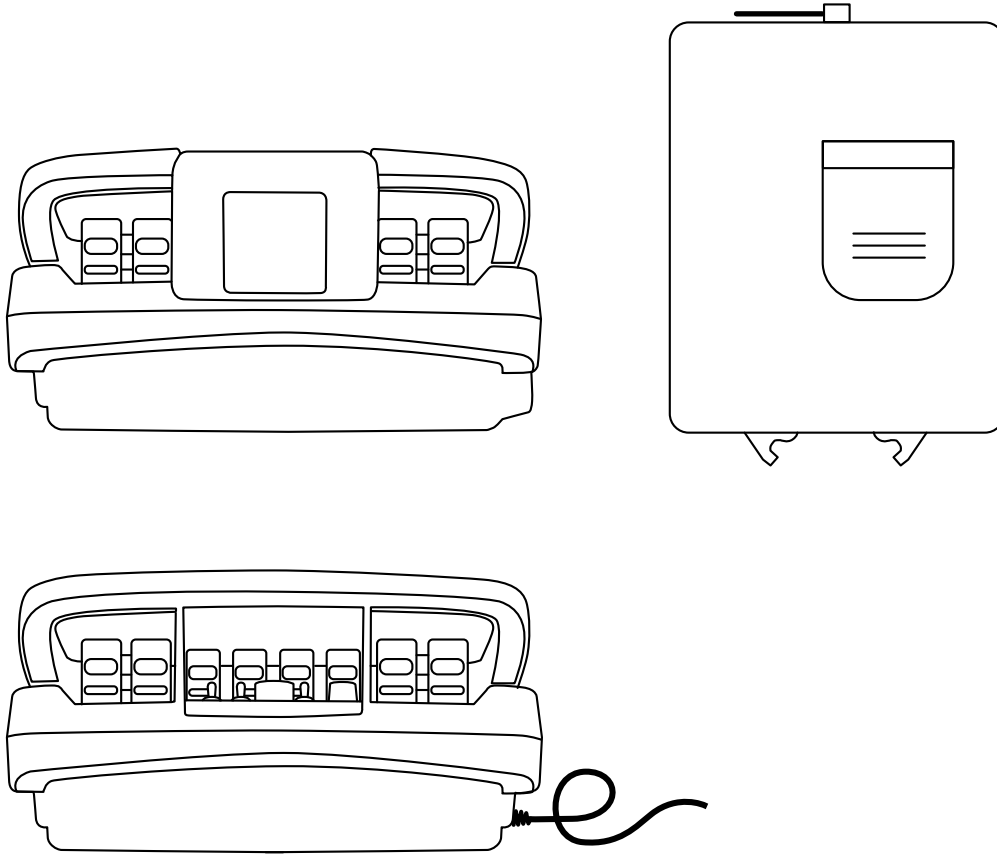

## USER MANUAL MANUEL DE L'UTILISATEUR

This manual, including all its parts, and all the instructions contained in it must be read carefully and understood before each installation, use, maintenance or repair of the ELCA radio remote control.

Ce manuel, y comprises toutes les parties qui le composent, et toutes les instructions y contenues doivent être lus attentivement et comprises avant toute opération d'installation, utilisation, entretien ou réparation de la radiocommande ELCA.

## OTHER LANGUAGES



<https://qrcode.elcaradio.biz/man/751d329b511fd3d4b4934de51c4b16ed>



# BRAVO

**ELCA**  
RADIOCONTROLS

# BRAVO-FUNK+ 915

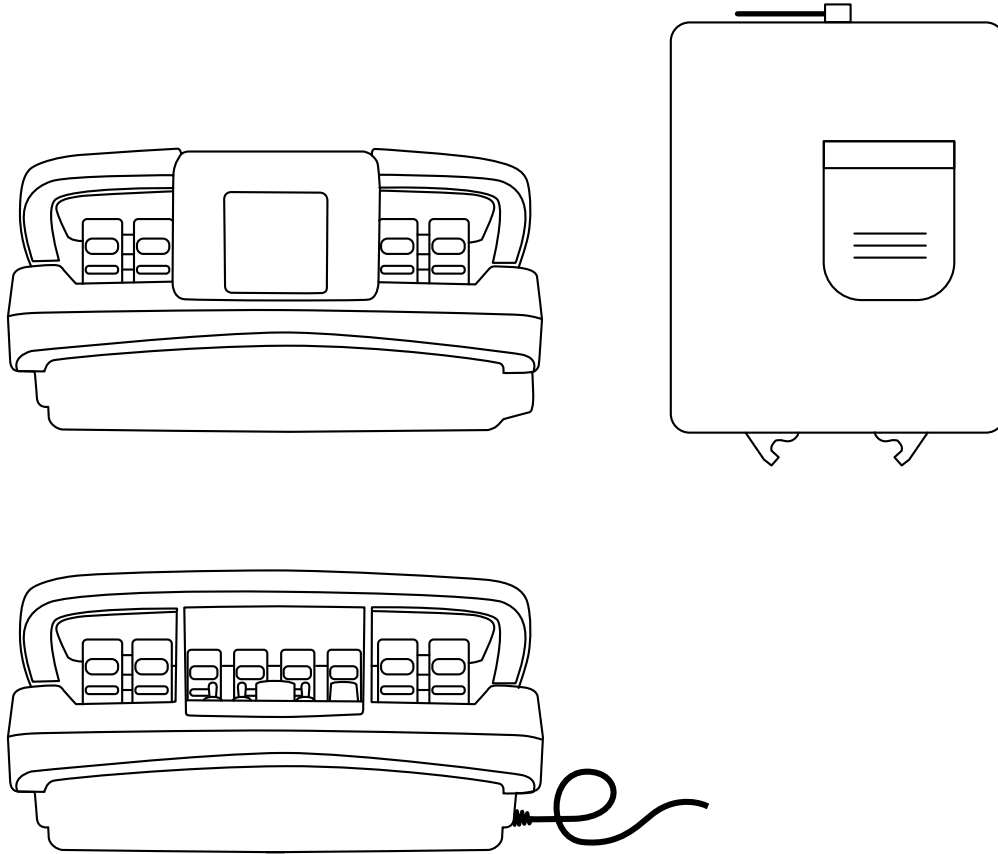

## USER MANUAL

Instructions translated from the original

This manual, including all its parts, and all the instructions contained in it must be read carefully and understood before each installation, use, maintenance or reparation of the ELCA radio remote control.

## OTHER LANGUAGES



<https://qrcode.elcaradio.biz/man/751d329b511fd3d4b4934de51c4b16ed>



# WARNING



THIS MANUAL, INCLUDING ALL ITS PARTS, AND ALL THE INSTRUCTIONS CONTAINED IN IT MUST BE READ CAREFULLY AND UNDERSTOOD BEFORE EACH INSTALLATION, USE, MAINTENANCE OR REPARATION OF THE ELCA RADIO REMOTE CONTROL.

FAILURE TO READ THE MANUAL AND COMPLY WITH ALL THE APPLICABLE WARNINGS AND INSTRUCTIONS, OR ANY RESTRICTION PROVIDED IN THIS MANUAL CAN CAUSE SERIOUS PHYSICAL INJURIES OR DEATH AND/OR DAMAGE TO PROPERTY.

THE ELCA RADIO REMOTE CONTROL IS NOT AN INDEPENDENT PRODUCT AND IS EXCLUSIVELY A COMPONENT OF A MACHINE THAT:

- PERMITS A RADIO REMOTE CONTROL TO BE USED IN AN APPROPRIATE MANNER,
- CAN BE OPERATED SAFELY AND IN COMPLIANCE WITH ALL LEGAL PROVISIONS, REGULATIONS AND STANDARDS APPLICABLE TO THIS RADIO REMOTE CONTROL.

ACCORDINGLY, IT IS THE RESPONSIBILITY OF THE MANUFACTURER AND THE DESIGNERS OF THE MACHINE ON WHICH YOU INTEND TO INSTALL THE ELCA RADIO REMOTE CONTROL to carry out a careful and in-depth risk assessment to determine whether the Elca radio remote control is suitable for the safe and efficient use of the Machine, taking into account the conditions of use and the intended uses, and that the installation, maintenance and use of the Elca radio remote control and all its components are carried out only and entirely in accordance with this Manual and in compliance with all local safety rules, standards and regulations (referred to herein as "Laws, Regulations and Standards").

With reference to the US market, the Laws, regulations and Standards include all regulations and standards of the Occupational Safety & Health Administration (OSHA) (<http://www.osha.gov>), all federal, state and local laws and provisions, the construction and electric devices codes and all applicable standards, including, but not only, ANSI standards.

It is the responsibility of the Manufacturer and the designers of the Machine on which you intends to install and use the Elca Radio Remote Control to make sure that the structure, condition, organisation and the markings of the Machine as well as how it is installed in its place of use are appropriate and allow the Machine to be used and controlled safely and reliably using the interface of the Elca Radio Remote Control.

IT IS THE RESPONSIBILITY OF THE USER OF THE SYSTEM AND THEIR DESIGNERS that the installation, maintenance and use of the Elca Radio Remote Control and all its components are carried out only and entirely in accordance with this Manual and in compliance with all applicable Laws, Regulations and Standards, also local. It is also the responsibility of the Owner, the system user and their designers to make sure that the structure, the condition, the organisation and the markings of the Machine and the place where the Elca Radio Remote Control is installed and used are appropriate and allow the Machine to be used and controlled safely and reliably using the interface of the Elca Radio Remote Control.

ONLY QUALIFIED AND SUITABLY TRAINED PERSONNEL ARE ALLOWED TO CONTROL AND USE THE ELCA RADIO REMOTE CONTROL AND THE MACHINE CONTROLLED BY THE ELCA RADIO REMOTE CONTROL.

ONLY QUALIFIED AND SUITABLY TRAINED PERSONNEL ARE ALLOWED ACCESS TO THE VICINITY OF THE MACHINE CONTROLLED BY THE ELCA RADIO REMOTE CONTROL.



INADEQUATE INSTALLATION, OPERATION, MAINTENANCE AND ASSISTANCE OPERATIONS ON THE ELCA RADIO REMOTE CONTROL CAN CAUSE SERIOUS PHYSICAL DAMAGE OR DEATH AND/OR DAMAGE TO PROPERTY. For further assistance refer to this Manual and all its parts, or else contact Elca. Elca is not responsible for and accepts no liability for any installation of the Elca Radio Remote Control carried out by Elca itself, or for any use or maintenance of the Elca Radio Remote Control that do not fully comply with all the instructions and warnings supplied by Elca and with all applicable Laws, Regulations and Standards, also local.

Elca is not responsible for and accepts no liability for any alterations or modifications of the Elca Radio Remote Control, or for the use of non-original Elca parts that are used together or incorporated inside the Radio Remote Control itself.

IT IS THE RESPONSIBILITY OF THE OWNER, AND USER OF THE SYSTEM AND ITS DESIGNERS to make sure that the Elca Radio Remote Control is always maintained and serviced in compliance with all the instructions and warnings provided by Elca, and in compliance with all applicable Laws, Regulations and Standards, also local.

IT IS THE RESPONSIBILITY OF THE OWNER, THE USER OF THE SYSTEM AND THEIR EMPLOYEES MANAGERS AND SUPERVISORS to make sure that all the Users of the Elca Radio Remote Control and all those that work or will work with or near the Machine operated by or through the Elca Radio Remote Control are completely and adequately instructed and trained by qualified persons on the correct and safe use of the Elca Radio Remote Control and the Machine, including without restrictions the complete familiarity with and understanding of the warnings and instructions provided by Elca, and all applicable Laws, Regulations and Standards, also local; it is equally also their responsibility to make sure that these Users or other Persons use or work always in a safe manner with the Elca Radio Remote Control and e ONLY in compliance with the instructions and warnings provided by Elca and in compliance with all applicable Laws, Regulations and Standards, also local. FAILURE TO COMPLY WITH THIS INSTRUCTION CAN CAUSE SERIOUS PHYSICAL INJURIES OR DEATH AND/OR DAMAGE TO PROPERTY.

IT IS THE RESPONSIBILITY OF THE OWNER, THE USER OF THE SYSTEM AND THEIR EMPLOYEES MANAGERS AND SUPERVISORS to make sure that the area where the Machine is located and is operated by the Elca Radio Remote Control is clearly marked and indicated, in compliance with all the instructions and warnings provided by Elca, and in compliance with all applicable Laws, Regulations and Standards, also local, and that there are sufficient indications that notify EVERYONE that the machine is operated by or through a Radio Remote Control, and that prohibit any unauthorised access to the area. FAILURE TO COMPLY WITH THIS INSTRUCTION CAN CAUSE SERIOUS PHYSICAL INJURIES OR DEATH AND/OR DAMAGE TO PROPERTY.

IF THE ELCA RADIO REMOTE CONTROL IS NOT USED SAFELY AND IN ADHERENCE TO THE INSTRUCTIONS AND WARNING PROVIDED BY ELCA, AND IN CONFORMITY WITH APPLICABLE LAWS, REGULATIONS AND STANDARDS, ALSO LOCAL, AND/OR IF USE OF THE RADIO REMOTE CONTROL IS PERMITTED TO USERS OR OTHER PERSONS THAT ARE NOT ADEQUATELY TRAINED TO USE THE SYSTEM OR THE MACHINE ON WHICH IT IS INSTALLED SAFELY AND CORRECTLY, CAN CAUSE SERIOUS INJURIES OR DEATH AND/OR DAMAGE TO PROPERTY.

# INDEX

<b>1 Use and Maintenance Manual</b> .....	<b>5</b>	12.9 Battery introduction .....	20
1.1 Structure .....	5	12.10 Disposal of batteries .....	20
1.2 Definitions .....	5	<b>13 Description of the Receiving Unit</b> .....	<b>21</b>
1.3 Symbols .....	5	13.1 Technical data .....	21
1.4 Who these instructions are for .....	5	13.2 Receiving unit data plate .....	21
1.5 Storage of the instructions .....	5	13.3 Indicator lights .....	21
1.6 Updating the Manual .....	5	<b>14 General operating instructions</b> .....	<b>22</b>
1.7 Intellectual property .....	6	14.1 Mother Board .....	22
<b>2 Series, Radio Remote Control and Unit</b> .....	<b>6</b>	14.2 Radio receiving module .....	22
<b>3 Conformity</b> .....	<b>6</b>	14.3 Board with identification code .....	22
3.2 Countries of use .....	6	14.4 Data Memory Card .....	22
<b>4 Manufacturer's identification</b> .....	<b>6</b>	14.5 LED card .....	22
<b>5 Assistance and spare parts</b> .....	<b>6</b>	14.6 Commands expansion cards .....	22
<b>6 Warranty</b> .....	<b>6</b>	14.7 DIP switch .....	22
<b>7 Safety warnings</b> .....	<b>6</b>	14.8 Command outputs .....	22
7.1 General information .....	6	<b>15 Description of cable control unit</b> .....	<b>23</b>
7.2 Risk analysis for remote-controlled Machines .....	7	15.1 Technical data .....	23
7.3 Delay in the command response time .....	8	15.2 Cable control unit data plate .....	23
7.4 Unintended activations of the commands .....	8	15.3 Indicator lights .....	23
<b>8 Radio Remote Control of the Range</b> .....	<b>8</b>	<b>16 General operating instructions</b> .....	<b>24</b>
8.1 Characteristics .....	8	16.1 Mechanical starting keyswitch .....	25
8.2 Frequencies and radio link .....	8	16.2 START command .....	25
8.3 Technical data of the range .....	9	16.3 STOP button .....	25
8.4 Identification of the Radio Remote Control .....	9	16.4 Activating the controls .....	25
8.5 Transportation and/or storage .....	9	16.5 Starting the cable control unit .....	25
8.6 Applications .....	9	16.6 Selecting the operating mode .....	26
8.7 Classification of the controls .....	10	16.7 Special functions in Drilling mode (operational) .....	26
8.8 Training of the personnel: Installation and maintenance .....	10	16.8 Relationships between joysticks .....	27
<b>9 Instructions for the User</b> .....	<b>10</b>	16.9 Machine motor command .....	27
9.1 Use of the Radio Remote Control and operating conditions .....	10	16.10 Jet Command .....	27
9.2 General warnings for the User .....	10	16.11 "GEAR" command .....	27
9.3 Environmental conditions of use .....	11	16.12 Pump Command .....	27
9.4 Warnings before starting work .....	11	16.13 Hammer Command .....	27
9.5 Warnings during normal use .....	11	16.14 Anti-tip function .....	27
9.6 Warnings for after its use .....	11	16.15 Activating the controls .....	27
9.7 Belt .....	12	16.16 Switching off the cable control unit .....	27
<b>10 Description of the Transmitting Unit</b> .....	<b>13</b>	16.17 Replacing the cable control unit .....	27
10.1 Technical data .....	14	<b>17 Warnings for the installation</b> .....	<b>28</b>
10.2 The Position of the controls and Connection diagram .....	14	17.1 Warnings for the Installer .....	28
10.3 Transmitting Unit data plate .....	14	17.2 Positions and mounting of the Receiving Unit .....	28
10.4 Indicator lights .....	14	17.3 Connecting the cable control unit to the machine .....	28
<b>11 General operating instructions</b> .....	<b>15</b>	<b>18 Installation</b> .....	<b>29</b>
11.1 Mechanical starting keyswitch .....	16	18.1 Testing .....	29
11.2 START command .....	16	<b>19 Maintenance</b> .....	<b>29</b>
11.3 STOP button .....	16	19.1 Maintenance of the Radio Remote Control - general instructions .....	29
11.4 Activating the controls .....	16	19.2 Routine radio remote control maintenance .....	29
11.5 Starting the Radio Remote Control .....	16	19.3 Maintenance of the cable control unit - general instructions .....	30
11.6 Selecting the operating mode .....	17	19.4 Routine cable control unit maintenance .....	30
11.7 Special functions in Drilling mode (operational) .....	17	19.5 Special maintenance of the cable control unit and radio remote control .....	31
11.8 Relationships between joysticks .....	18	19.6 Actuators (buttons, joysticks and potentiometers) .....	31
11.9 Machine motor command .....	18	<b>20 Guide to solving problems</b> .....	<b>32</b>
11.10 Jet Command .....	18	20.1 Solutions in the event of malfunctions of the transmitting unit .....	32
11.11 "GEAR" command .....	18	20.2 Solutions in the event of malfunctions of the receiving unit .....	32
11.12 Pump Command .....	18	20.3 Solutions in the event of cable control unit malfunctions .....	33
11.13 Hammer Command .....	18	<b>21 Decommissioning and disposal</b> .....	<b>33</b>
11.14 Anti-tip function .....	18	21.1 Decommissioning .....	33
11.15 Activating the controls .....	18	21.2 Disposal .....	33
11.16 Interruption of the radio link .....	18	<b>22 Correspondence of FUNK+ functions for drilling machine</b> .....	<b>34</b>
11.17 Charging the Transmitting Unit .....	18		
11.18 Switching off of the Transmitting Unit .....	18		
11.19 Replacing the Transmitting Unit .....	19		
<b>12 Charging system of the Transmitting Unit</b> .....	<b>19</b>		
12.1 Instructions for use .....	19		
12.2 Charging system technical data .....	19		
12.3 First aid .....	19		
12.4 Battery storage .....	20		
12.5 Charging indicator lights .....	20		
12.6 Battery removal .....	20		
12.7 Connection to the charging system .....	20		
12.8 Removal from the charging system .....	20		

# 1 Use and Maintenance Manual

## 1.1 Structure

The Manual should be read, understood and applied by the Owner of the Radio Remote Control, by the User and by all those who, for whatever reason, operate the Radio Remote Control or the Machine on which it is installed.

The contents of the Instruction manual for use and maintenance is supplemented by the following documents:

- “Arrangement of Controls” that contains the configuration of the Transmitting Unit and the names of the commands sent to the Receiving Unit;
- “Connection diagram” that indicates the correspondence of the commands sent by the Transmitting Unit and those available in the Receiving Unit.

The Instruction manual for use and maintenance is an integral part of the Elca Radio Remote Control and therefore of the Machine that is equipped with the Radio Remote Control. It is the responsibility of the Manufacturer of the Machine or the system on which the Radio Remote Control is installed to ensure that the Instruction Manual is inserted in the instruction manual of the Machine.

Further information on the operation of the radio remote control system, particularly if made to the customer's own specifications, can be found in the documents attached to the manual that should be considered as an integral part of the Manual itself.

## 1.2 Definitions

Please contact ELCA if any instructions, symbols, warnings or images are not clear or understandable and in case of doubts or questions. The “Manufacturer's identification” can be found on page 6 or with the QR Code here on the side.



The meanings of the terms in the entire Manual, including all its parts, are shown below:

**Unit:** the single units (transmitting unit, receiver, cable control unit) comprising the Elca control system.

**Radio Remote Control:** wireless control system (CCS: Cableless Control System) composed of a Transmitting unit and a Receiving unit that communicate with each other via radio connection.

**Transmitting unit:** portable component (remote station) through which the user interfaces with the Radio Remote Control.

**Receiving unit:** component fixed stably to the Machine (base station) that constitutes an interface between the Radio Remote Control and the other parts of the machine.

**Cable control unit:** control system via cable.

**Machine:** the machine, as defined by Directive 2006/42/CE and by other local regulations, and every other device, machinery, equipment, system, application, etc., on which the Elca Radio Remote Control is installed or that is controlled by it.

**Manufacturer:** the entity that designs and/or constructs a Machine and that decides to install a Radio Remote Control in order to operate the Machine.

**Installer:** the entity, specialised technician, that plans and/or carries out the installation of the Elca Radio Remote Control on a Machine in order to operate its controls.

**User:** the entity that materially uses the Elca Radio Remote Control as a device for operating the controls of a Machine.

**Maintenance technician:** the entity, specialised technician, that carries out routine and extraordinary maintenance on the Elca Radio Remote Control, in order to keep it undamaged and running efficiently.

**Manual or Instruction manual:** document consisting of the Manual, Position of the controls and the Connection diagram.

**Person:** individual, natural or legal person and/or every entity, however considered.

**Owner:** the owner of the Radio Remote Control.

The functions indicated for the Manufacturer, the Installer, the User and the Maintenance Technician can be carried out by a single entity, where these have the skills and assume the relative responsibilities. Each entity should be aware of the instructions in the Manual for the work that it carries out.

For example, if a Manufacturer also acts as an Installer, and/or Maintenance Specialist, it should understand and follow also the instructions specifically directed at these entities. The same criteria should be applied in the case where, for example, a User assumes the function of manufacturer and/or Installer.

## 1.3 Symbols

The parts of the Manual that are drawn attention to by this symbol should be read very carefully.

The parts of the Manual that are drawn attention to by this symbol contain warnings, information and/or instructions that are extremely important for safety issues: failure to understand these parts could be dangerous for Persons and/or property.

## 1.4 Who these instructions are for

The Instruction Manual is for the User, the Owner of the Radio Remote Control, the Installers, the Manufacturers and all those Persons who, for whatever reason, are operating the Radio Remote Control or the Machine on which it is installed.

The Manual should be read, understood and applied, in all its parts, by:

- the Owner and/or the person responsible for operating the Machine and/or the Elca Radio Remote Control;
- the Manufacturer of the Machine who decides to equip it with a Radio Remote Control;
- the Installer of the Radio Remote Control or the entity that takes care of its fitting on a Machine, on a device, on a system, etc., and/or that has the responsibility for its operation;
- the safety manager of the workplace where the Radio Remote Control is used;
- the Users, namely those who materially, and for any purpose, are enabled/authorised/entrusted with using the Radio Remote Control or simply find themselves in this situation;
- the Maintenance technician;
- Those who, for any reason, find themselves operating the Radio Remote Control and/or the Machine, the system, the device and/or the system on which the Elca Radio Remote Control is installed, or which is controlled by it.

The instructions concerning the installation and maintenance of the Radio Remote Control are for qualified personnel and for their application specialised professional expertise is required: none of the operations for which qualified personnel are required can be carried out by Persons or entities that do not have the specific professional skill required.

## 1.5 Storage of the instructions

The Instruction Manual should be taken good care of and should accompany the Radio Remote Control throughout its working life. No part of the manual should be removed, torn or arbitrarily modified.

The Instruction Manual should be available for all those requiring it and at any moment it becomes necessary to consult it.

Another copy of the Manual should be requested if it deteriorates. The copy will be supplied after communicating the serial number of the Radio Remote Control and at the expense of the person requesting it.

## 1.6 Updating the Manual

The contents of this manual are subject to change without prior notice, therefore the operator is required to verify (before using the radio remote control) that the information contained in this publication is consistent with the device in their possession.

Elca is solely responsible for the instructions compiled and validated by Elca itself (Original Instructions); in order to be able to check the accuracy of the translation, any translations should always accompany the Original Instructions.

Contact ELCA in the event there are instructions, warnings or indications which may prove to be unclear.

### 1.7 Intellectual property

This manual and any annexed documents are the property of ELCA and all rights are reserved. No part of this publication (for example the structure, the contents, the instructions, the figures, the diagrams, the photos) may be reproduced or transmitted (including photocopies and web) for any reason without the written authorisation of Elca.

## 2 Series, Radio Remote Control and Unit

Elca Radio Remote Controls provide a control interface to be used on Machines to manage the command and control system.

The Radio Remote Controls have been designed to be used at a suitable distance and position.

The radio remote control in the series BRAVO consists of a transmitting unit and a receiving unit.

## 3 Conformity

It is the responsibility of the recipients of these instructions to:

- check the radio frequency band permitted in the country where it will be used;
- check that the Radio Remote Control operates inside this band;
- check the country's applicable standards;
- check that the Radio Remote Control operates correctly in conformity with them.

In no way can the conformity of the Radio Remote Control be modified, making changes to it or carrying out technical interventions that change the way it works.

For the instructions and use of the Elca Radio Remote Controls, local regulations must be respected.

These regulations obligate the protection of the conformity of the products with local regulations, and the specific standards regarding the safe use of the Radio Remote Controls or electric devices, both inside and outside the workplace.

### 3.1.1 FCC and IC Conformity statement

Each BRAVO series' radio remote control working in the frequency band 915.000 - 928.000 MHz complies with the essential requirements of the following regulations:

- FCC (Federal Communication Commission) Part 15
- IC (Industry Canada) RSS-102

Transmitting Unit	Receiving Unit
AT BRAVO-FUNK+ 915	AR BRAVO-FUNK+ 915
FCC ID: 2ABS7-ATBRFUP915	FCC ID: 2ABS7-ARBRFUP915
IC: 30220-ATBRFUP915	IC: 30220-ARBRFUP915

### 3.1.2 Federal Communications Commission (FCC)

This device complies with part 15 of the FCC Rules.

Operation is subject to the following two conditions:

- (1) this device may not cause harmful interference, and
- (2) this device must accept any interference received, including interference that may cause undesired operation.

Any changes or modifications not expressly approved by the party responsible for compliance could void the user's authority to operate the equipment.

Note: This equipment has been tested and found to comply with the limits for a Class B digital device, pursuant to part 15 of the FCC Rules. These limits are designed to provide reasonable protection against harmful interference in a residential installation.

This equipment generates, uses, and can radiate radio frequency energy and, if not installed and used in accordance with the instructions, may cause harmful interference to radio communications. However, there is no guarantee that interference will not occur in a particular installation.

If this equipment does cause harmful interference to radio or television reception, which can be determined by turning the equipment off and on, the user is encouraged to try to correct the interference by one or more of the following measures:

- Reorient or relocate the receiving antenna.
- Increase the separation between the equipment and receiver.
- Connect the equipment to an outlet on a circuit different from that to which the receiver is connected.
- Consult the dealer or an experienced radio/TV technician for help.

### 3.1.3 Industry Canada (IC)

This device complies with Industry Canada licence/exempt RSS standard(s).

Operation is subject to the following two conditions:

- (1) this device may not cause harmful interference, and
- (2) this device must accept any interference received, including interference that may cause undesired operation.

### 3.2 Countries of use

BRAVO series' radio remote controls working in the frequency band 915.000 - 928.000 MHz can be used in the US and Canadian markets.

## 4 Manufacturer's identification

Radio Remote Control Manufacturer	ELCA S.r.l.
Registered office	Via del Commercio, 7/b - 36065 Mussolente (VI) - ITALY
Telephone	+39 0424 578500
Fax	+39 0424 578520
E-mail	info@elcaradio.com
Site	www.elcaradio.com

## 5 Assistance and spare parts

For technical assistance and/or spare parts, please contact Elca. When sending a request regarding an Elca Radio Remote Control the serial number (Serial Num.) of the Radio Remote Control itself must be provided. The serial number (Serial Num) can be found on the Unit's data plate (see paragraph 10.3 , paragraph 13.2 , and paragraph 15.2 ).

## 6 Warranty

The general warranty conditions can be found in the dedicated section of the website [www.elcaradio.com](http://www.elcaradio.com).



## 7 Safety warnings

### 7.1 General information

All the warnings and instructions contained in this chapter are relevant for safety purposes.

Failure to follow the instructions in the Manual supplied by Elca and applicable safety legal provisions, also local, regulations, norms and standards can cause serious injuries to Persons and damage to property.

It is the responsibility of the Manufacturer and/or the designer of the Machine, the Installer, the Maintenance Technician and the Persons responsible for the use of the Machine and the workplace, that the installation, maintenance and use of the Elca Radio Remote Control and all its components are done only and entirely in compliance with the instructions provided by Elca e and in conformity with all applicable safety standards and regulations in force in the countries where the Machine and Radio Remote Control are used.

The Manufacturer of the Machine bears responsibility for the installation and use of Radio Remote Control on any application.

The Manufacturer of the Machine or whoever intends to use or install an Elca Radio Remote Control on a Machine should first of all:

- check whether the Machine that you want to equip with a Radio Remote Control is suitable for being used with a Radio Remote Control safely and efficiently;
- carry out a comprehensive risk assessment taking into contact the construction, functional and/or performance characteristics of the Machine, the use of the Machine, the location and the environment where the Machine will be used, the structure where the Machine will be or is installed, the interaction between the Machine and the other equipment and the personnel, the safety conditions when the Machine is operating, the effective and potential different conditions of use, the conditions that can be created after the installation of a Radio Remote Control and the characteristics and limitations of the Elca Radio Remote Control.



To this end refer to, but not only, ISO 12100 and ISO 14121, that lay down the conditions through which a correct comprehensive risk analysis can be carried out as well as the adoption of the necessary safeguards.

Even without any legal or regulatory restrictions, a Radio Remote Control should never be used if the Manufacturer or those who intend to use or install a Radio Remote Control on a Machine cannot:

- carry out an appropriate and comprehensive analysis of the risks in relation to the safety of the Machine after the installation of the Radio Remote Control;
- provide adequate professional experience and/or technical expertise to properly carry out the risk analysis;
- correctly install the Radio Remote Control in accordance with this Manual and all the applicable Laws, Regulations and Standards, also local;
- implement all the safety provisions so that the machine fitted with the Radio Remote Control can be used safely without creating dangerous situations;
- adopt the appropriate technical remedies and actions from an information point of view to allow the User and Maintenance Technician of the Machine equipped with a Radio Remote Control to operate it safely;
- implement all procedures required and appropriate for eliminating or reducing the risks connected to using the Machine fitted with a Radio Remote Control.



THE INSTALLATION AND USE OF THE ELCA RADIO REMOTE CONTROL IS ONLY PERMITTED IF THE COMPREHENSIVE ASSESSMENT OF THE RISKS CONFIRMS THE INSTALLATION OF AN ELCA RADIO REMOTE CONTROL IS SUITABLE, EFFECTIVE AND SAFE FOR OPERATING THE MACHINE ITSELF, AND IF THE USE OF THE RADIO REMOTE CONTROL ON THE MACHINE IS PERMITTED BY AND IN CONFORMITY WITH APPLICABLE LAWS, REGULATIONS AND STANDARDS, ALSO LOCAL, AND WITH THIS MANUAL.

THE MANUFACTURER OF THE MACHINE OR THOSE WHO INTEND TO INSTALL AN ELCA RADIO REMOTE CONTROL ON A MACHINE IS RESPONSIBLE:

- FOR AN ASSESSMENT OF THE RISKS;
- FOR THE DECISION TO USE THE ELCA RADIO REMOTE CONTROL ON THE MACHINE;
- FOR IMPLEMENTING ALL THE NECESSARY OR ADVISABLE MEASURES FOR REDUCING OR ELIMINATING THE RISKS RESULTING FROM THE MACHINE AND, WITHOUT RESTRICTION, FROM THE USE OF THE RADIO REMOTE CONTROL FOR CONTROLLING THE MACHINE;
- FOR THE OBSERVANCE OF THE STANDARDS AND REGULATIONS AIMED AT MAINTAINING SAFETY.



THE ELCA RADIO REMOTE CONTROL IS NOT AN INDEPENDENT PRODUCT AND IS EXCLUSIVELY A COMPONENT OF A MACHINE THAT:

- PERMITS A RADIO REMOTE CONTROL TO BE USED IN AN APPROPRIATE MANNER,
- CAN BE OPERATED SAFELY AND IN COMPLIANCE WITH ALL LEGAL PROVISIONS, REGULATIONS AND STANDARDS APPLICABLE TO THIS RADIO REMOTE CONTROL.



ELCA IS NOT RESPONSIBLE FOR, AND DOES NOT ACCEPT ANY LIABILITY FOR, THE COMPATIBILITY BETWEEN THE RADIO REMOTE CONTROL AND THE MACHINE OR THE USE YOU WANT TO MAKE OF IT, IRRESPECTIVE OF WHETHER IT FALLS WITHIN THOSE ENVISAGED OR NOT, OR FOR ANY PROBLEM REGARDING THE SUITABILITY OF THE MACHINE AND ITS CONTROL SYSTEMS TO BE MANAGED USING THE RADIO REMOTE CONTROL.

IN THE SAME WAY ELCA IS NOT RESPONSIBLE FOR, AND DOES NOT ACCEPT ANY LIABILITY FOR, THE ASSESSMENT OF THE RISKS TO BE CARRIED OUT WHENEVER TAKING INTO ACCOUNT THE RADIO REMOTE CONTROL IN GENERAL, OR SPECIFICALLY THE ELCA RADIO REMOTE CONTROL, NOR FOR THE SUITABILITY OF OPERATING THE MACHINE WITH A RADIO REMOTE CONTROL IN GENERAL OR SPECIFICALLY THE ELCA RADIO REMOTE CONTROL, IN RELATION TO THE STRUCTURE WHERE THE MACHINE IS OR WILL BE USED, AS WELL AS THE ENVIRONMENTAL AND/OR OPERATING CONDITIONS IN WHICH THE MACHINE IS OR WILL BE USED.

Without limiting what was stated above, Elca is not responsible for, and does not accept any liability for:

- defective installation or installation not complying with this Manual, with any other instructions provided by Elca, and with all applicable Laws, Regulations and Standards, also local;
- installation carried out on Machines, appliances, devices, equipment and/or systems for which the use of a Radio Remote Control is not permitted by its Manufacturer or by applicable Laws, Regulations and Standards, also local, and for which the installation and/or use of a Radio Remote Control could cause safety issues or other hazardous situations that are not adequately eliminated and/or reduced, in respect of applicable Laws, Regulations and Standards, also local;
- the use of the Elca Radio Remote Control that does not comply with what is written in this Manual and in any other instructions supplied by Elca and with applicable Laws, Regulations and Standards, also local;
- the use of the Radio Remote Control in locations, climatic and/or weather conditions that are not permitted or not recommended by applicable Laws, Regulations and Standards, also local, forbidden by the instructions in this Manual, or in relation to which there are risks of damage and/or incorrect operation of the Radio Remote Control (for example: temperatures outside the limits indicated in the paragraph 9.3, situations with a risk of explosion, contact with liquids or fluids);
- the use of the Radio Remote Control in work conditions that do not allow the User to maintain complete and continuous visual control of the movements of the Machine and the load, if present;
- the use of the Radio Remote Control in a manner different to, or for uses other than those permitted and/or not in complete conformity with the instructions for use and maintenance contained in this Manual;
- the lack of, or poor maintenance of the Radio Remote Control, both routine and special, or the failure to repair any damage, wear or malfunction of the Elca Radio Remote Control;
- damage and/or deterioration of any part or function of the Radio Remote Control;
- failure to take the Elca Radio Remote Control out of service in the case it or one of its components develops a fault or malfunctions;
- the use of non-original parts or components that were not supplied by Elca;
- technical assistance for the Elca Radio Remote Control carried out by a company other than Elca or that is not part of its assistance network.

**7.2 Risk analysis for remote-controlled Machines**

The Manufacturer of the Machine on which you intend to install the Radio Remote Control and its designers need to carry out a careful and in-depth risk assessment to determine whether the Elca radio remote control is suitable for the safe and efficient use of the Machine, taking into account the conditions of use and the intended uses, and that the installation, maintenance and use of the Elca radio remote control and all its components are carried out only and entirely in accordance with this Manual and in compliance with all local safety rules, standards and regulations (referred to herein as "Laws, Regulations and Standards").

In carrying out the risk analysis to establish whether the Radio Remote Control can be installed on a Machine, the Manufacturer of the Machine and/or the Installer of the Radio Remote Control must respect all Laws, Regulations and Standards, also local, regarding the assessment of the risks and the safety of the Machine and the following recommendations:

- some Machines cannot be fitted with a Radio Remote Control, as established in paragraph 8.6 ). Also all the other circumstances that might limit, impede or impose conditions for the use of a Radio Remote Control on the Machine, or which could effect it being used correctly and safely should be evaluated.
- The radio link between the two Units can be interrupted (see paragraph 8.2.3 ).
- all the information regarding the installation, use and maintenance supplied by Elca should be taken into consideration (see paragraph 8.6, paragraph 9 and paragraph 19 ).
- there is a delay between the release of a command in the Transmitting Unit and the deactivation of the relative output in the Receiving Unit (see paragraph 7.3 ).

- there is a delay between the activation of a command in the Transmitting Unit and the activation of the relative output in the Receiving Unit (see paragraph 7.3).
- additional measures might be needed to protect the actuators (see paragraph 7.4).
- it is possible that a command is activated or deactivated because of electrical and/or mechanical faults.

### 7.3 Delay in the command response time



In normal conditions, the delay between the activation of a command in the Transmitting Unit and the activation of the relative output in the Receiving Unit requires a time equal to the "Command response time" (typical) indicated in the Technical Data (see paragraph 8.3). In situations where there is a poor quality radio link (for example: interference, range of action reached) this delay can extend up to the "Maximum stop time" indicated in the Technical Data (see paragraph 8.3).

It should be remembered that due to the characteristics of the radio medium (for example: interference, range of action reached), the delay between the release of a command in the Transmitting Unit and the deactivation of the relative output in the Receiving Unit can extend up to the "Maximum stop time" indicated in the Technical Data (see paragraph 8.3).

The Manufacturer of the Machine, the Installer, the Owner, the User and the Maintenance Technician need to make sure that these delays can never lead to a situation of danger in the specific application.

### 7.4 Unintended activations of the commands

The User should operate the Radio Remote Control correctly, following the use and maintenance instructions.



If the Unit is used correctly, accidental contact with parts of the body of the User or with foreign objects, does not cause the unintended operation of the actuators.

Any action is carried out on the Transmitting Unit, or part of it, in order to operate the actuators in a way other than that indicated in the Manual is an incorrect use of the Radio Remote Control and cause serious damage to Persons and/or property.

The User should use the Radio Remote Control in compliance with the use and maintenance instructions and all applicable Laws, Regulations and Standards, also local, in the country where the Radio Remote Control and the Machine are used, always maintaining control of the Radio Remote Control and the position of use just as described in the specific part of the Transmitting Unit.

The Manufacturer of Machine and/or the Installer should assess and eventually adopt additional protective measures for the actuators (for example: two-hand controls, "dead-man" function) in the case where particular locations, equipment and working modes can create situations of risk and in the case this is required by the applicable Laws, Regulations and Standards in the country where the Radio Remote Control and the Machine are used.

It is possible that a command is activated or deactivated because of electrical and/or mechanical faults, which can affect the Radio Remote Control and/or the Machine.

The Manufacturer of the Machine and/or the Installer of the Radio Remote Control should carefully assess what the consequences of this malfunction are. If the risk analysis requires it, protective measures should be prepared that avert, reduce or signal situations of potential risk.

If a command is activated and/or deactivated because of electrical and/or mechanical faults:

- press the STOP button to put the machine in a safe state,
- disable the Radio Remote Control and cease using the "Machine+Radio Remote Control" system until the problem is solved by means of the required technical intervention.

## 8 Radio Remote Control of the Range

### 8.1 Characteristics

An Elca Radio Remote Control of the BRAVO series belongs to a family of industrial Radio Remote Controls, that can mainly be used, but not only, for controlling lifting and transportation apparatus.

With a Radio Remote Control it is possible to control the Machine from a remote position and without a physical connection using wifi or connection cables.

The User manages the machine from a distance using a Transmitting Unit (portable) that dialogues with a Receiving Unit (fixed) installed on the Machine itself.

This chapter contains images of the individual units that make up the Radio Remote Control, please look at the parts concerning each Unit.

### 8.2 Frequencies and radio link

#### 8.2.1 Frequencies

The radio link between the Elca Radio Remote Control units in the BRAVO range occurs at one of the frequencies permitted under European regulations in force at the time when placed on the market.

The BRAVO range operates using the 915.000 - 928.000 MHz frequency band.



Depending on the specific market there are laws and regulations that establish the frequency with which a Radio Remote Control can operate.

If these laws and standards are not respected, the Radio Remote Control cannot and should not be used.

It is not the responsibility of Elca to check whether the Radio Remote Control is configured during installation and used with a frequency other than that permitted in the country where it is to be used.

The Radio Remote Control is made in such a way that when started it looks for a free frequency to use. The automatic search for a frequency allows a free frequency to be found free from interference. It also allows other apparatus in the vicinity not to be disturbed and vice-versa not to be disturbed by them.

#### 8.2.2 Technical data of the frequency band

Data	Value
Frequencies used in the band	256
RF power	<25 mW ERP
Channel spacing used	25 kHz

#### 8.2.3 Description of the radio link

The Transmitting Unit communicates with the Receiving Unit using a radio link.

The system uses electromagnetic waves to transport the control signals.

The Transmitting Unit and the Receiving Unit communicate through codified messages that contain a unique code.

Each unit can decode only the messages coming from the Unit that possess the same code. This is to exclude the possibility that another radio apparatus could send commands to the Machine on which the Radio Remote Control is installed.

Each Radio Remote Control operates within and not beyond a certain distance, beyond which the communication between the Units is lost. This distance is called "operating range".



The radio link is sensitive to particular conditions in the environment, like for example the presence of metal obstacles or electromagnetic interference.

If the connection between the Transmitting Unit and the Receiving Unit is interrupted or is incorrect, the system provides that the Receiving Unit commands the Machine to stop.

There are various reasons for an interruption of the connection:

- programmed automatic shut-off;
- Transmitting Unit low battery;
- no power supply to the Transmitting Unit;
- STOP button pressed;
- automatic connection interruption;
- operating range exceeded;
- presence of metal obstacles.

For the Machine to stop, however, the wiring between the units must have been made correctly.

When the radio link is interrupted all the outputs of the Receiving Unit are disabled. To be able to activate/deactivate the controls of the Machine using the Transmitting Unit the Radio Remote Control must be switched on again.

### 8.2.4 Stop

The shut-down is a safety function that puts the Machine in a safe state each time it is necessary to stop it because of a potentially dangerous situation.

The stop function can activate:

- by the operator pressing the red STOP button on the Transmitting Unit (manual mode).
- automatically by the Receiving Unit if the radio link between the Units is incorrect or interrupted (automatic mode).

**! THE USER MUST ALWAYS PAY THE UTMOST ATTENTION TO THE SAFE AND CORRECT WORKING OF THE MACHINE IN ACCORDANCE WITH THE INSTRUCTIONS AND WARNINGS PROVIDED IN THIS MANUAL, THE INSTRUCTIONS AND WARNINGS IN THE MANUAL OF THE MACHINE AND IN COMPLIANCE WITH ALL APPLICABLE LAWS, REGULATIONS AND STANDARDS, ALSO LOCAL.**

THE ACTIVATION OF THE STOP BUTTON OR THE RETURN OF THE ACTUATORS TO THE REST POSITION MIGHT NOT CAUSE THE MACHINE TO STOP IMMEDIATELY.

THE STOP BUTTON MIGHT NOT ACTIVATE A BRAKE. MOREOVER, DIFFERENT MACHINES HAVE DIFFERENT RESPONSE TIMES AND STOPPING DISTANCES. EVEN IF THE STOP FUNCTION IS USEFUL, THE USER SHOULD BE FULLY AWARE OF THE MOVEMENTS AND WORKING AREAS OF THE MACHINE AND SHOULD PROVIDE FOR THE SAFE OPERATION OF THE MACHINE, TAKING INTO CONSIDERATION THESE RESPONSE TIMES AND STOPPING DISTANCES.

FAILURE TO COMPLY WITH THESE INSTRUCTIONS, EVEN TEMPORARILY, CAN CAUSE SERIOUS INJURIES OR DEATH OR DAMAGE TO PROPERTY.

**i** The stop function using the Radio Remote Control is only available if the Radio Remote Control has been started.

**! Never leave the Transmitting Unit unattended so that there is no doubt about the availability of the stop function.**

The “useful life”, as defined in international standards and requirements, of the stop function is 20 years. In any case, the Radio Remote Control should be replaced before then. The “useful life” cannot be understood as a warranty period.

After the STOP button is activated in the Transmitting Unit, the Machine is no longer controlled by the Radio Remote Control. The possible risks deriving from the activation of the stop function should be evaluated both by the Installer of the Radio Remote Control as well as by the Manufacturer and the Owner of the Machine on which the Radio Remote Control is installed. The User of the Radio Remote Control should be adequately trained in this regard.

### 8.3 Technical data of the range

Data	Value
Operating range	150 m
Command response time (typical)	<100 ms
Stop time (typical)	100 ms
Maximum stop time	0.5 s
Performance Level of the "stop protection" according to ISO 13849-1	Cat. 3 PL d (Cat. 4 PL e)

### 8.4 Identification of the Radio Remote Control

The serial number (Serial Num.) uniquely identifies the Radio Remote Control.

The serial number can be found on the data plate of the Radio Remote Control; each unit of the Radio Remote Control has its own data plate.

When sending a request regarding an Elca Radio Remote Control the serial number (Serial Num.) of the Radio Remote Control itself must be provided.

The Serial Num. should be reported in all communications with Elca or with Persons who require information, spare parts or technical data regarding the Radio Remote Control.

**i** Do not remove the data plate on the Units from their position, since removing it will immediately void the warranty. If the data plate has been altered or damaged, contact Elca for a replacement.

### 8.5 Transportation and/or storage

The Radio Remote Control and all its parts should be transported and stored according to the following parameters and environmental conditions:

Operation	Temperature
Transportation	from -25°C to +55°C
Storage	from -25°C to +55°C

The original packaging should be kept for the entire life of the product.

Use the original packaging for transporting and storing the Radio Remote Control in all the phases of its life, for example before installing and after its removal.

### 8.6 Applications

An Elca Radio Remote Control of the BRAVO range can be used for various applications: the suitability of the Radio Remote Control for each different application, especially for safety reasons, should be assessed by the Manufacturer of the Machine.

The BRAVO range is most often used on Machines for lifting and moving materials, objects, and loads in general (for example: overhead travelling crane, lifting crane, etc.) if permitted by the instructions in this Manual.

**! An Elca Radio Remote Control should not be installed on Machines whose application or function is not permitted by this Manual or by applicable Laws, Regulations and Standards, also local.**

**THE INSTALLATION OF AN ELCA RADIO REMOTE CONTROL ON OTHER MACHINES OR FOR OTHER FUNCTIONS CAN CAUSE SERIOUS INJURY OR DEATH OR DAMAGE TO PROPERTY.**

Elca is not responsible for, and does not accept any liability for, applications of the Radio Remote Control in situations where safety conditions are poor or non-existent.



The Manufacturer of Machine should assess and eventually adopt additional protective measures for the actuators (for example: two-hand controls, "dead-man" function) where particular locations, equipment and working modes can cause accidental collisions.

In addition to the above, a BRAVO Radio Remote Control should not be installed:

- On Machines operating in environments that require explosion-proof equipment, or in all those situations that carry a risk of explosion.
- On Machines for moving, lifting and transporting Persons, where the characteristics of the Machine to be used for these functions and the risks connected to them and/or connected to the use of a Radio Remote Control do not allow the Manufacturer of the Machine to guarantee compliance with all safety requirements. These requirements should be taken into consideration when designing and manufacturing the Machine, also taking into account the use of the Radio Remote Control. The Manufacturer of the Machine can allow the installation and use of the Radio Remote Control on these applications under its own responsibility.
- On Machines that cause or might cause dangerous situations in the event of a stoppage due to the loss of the radio link.
- On Machines that, because of their functions or characteristics and/or risks connected to their use, do not allow the use of a Radio Remote Control in conditions where there are no risks.
- On any type of lifting equipment (for example: magnets, pliers, suction cups) when the loss of the radio link or the deactivation of the controls can cause the release of the load being held, with the risk of harming Persons and/or damaging property. The Manufacturer of the Machine can allow the installation and use of the Radio Remote Control for these applications under its own responsibility.
- If the applicable legislation in the country where the Machine is used, and also the local safety regulations and standards, also with reference to safety in the workplace, do not allow the use of Radio Remote Controls for commanding and/or controlling Machines.

THE INSTALLATION OF AN ELCA REMOTE RADIO CONTROL ON MACHINES AND IN SITUATIONS DESCRIBED ABOVE CAN CAUSE SERIOUS INJURIES OR DEATH OR DAMAGE TO PROPERTY.

- the warning deriving from the risk analysis connected to the installation and/or maintenance of the Radio Remote Control;
- all the applicable Laws, Regulations and Standards, also local, including also safety aspects;
- the operation and the requisites of the Machine on which the Radio Remote Control is installed;
- the warnings and the instructions in this Manual and in other documentation of the Radio Remote Control and the Machine fitted with the Radio Remote Control;
- the instructions of the Manufacturer of the Machine and the person responsible for safety in the workplace where the "machine+Radio Remote Control" system is used.

## 9 Instructions for the User



All the instructions and warnings of the Elca Radio Remote Control in this Manual should be read and understood. Failure to understand or follow them can cause serious injuries or death or damage to property.

### 9.1 Use of the Radio Remote Control and operating conditions

For the correct use of the Radio Remote Control all the warnings and instructions in the Manual must be respected. It is also necessary to comply with what is reported in the documentation of the Radio Remote Control and the Machine on which the Radio Remote Control is installed.

It is necessary to comply with all workplace safety and accident prevention regulations.

Finally, all applicable Laws, Regulations and Standards, also local, must be respected.

Below are some examples of behaviours to be avoided in using the Radio Remote Control.

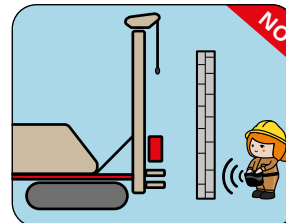

Work with the machine in sight!

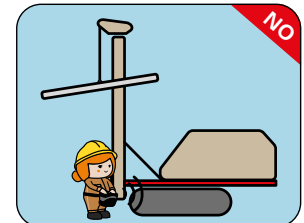

Do not stand under hanging loads!

These examples are given purely by way of example and do not cover all possible incorrect uses of the Radio Remote Control.

It is the responsibility of the Manufacturer of the machine and the User to evaluate and establish any measures for avoiding the possible incorrect use of the Radio Remote Control or the Machine.

### 9.2 General warnings for the User

The User should:

- check that the units of the Radio Remote Control are undamaged and operational;
- keep the Transmitting Unit safe so that it cannot be used by unauthorised or unqualified personnel;
- check that the STOP button is working correctly;
- check that the controls of the Machine are working correctly;
- immediately notify superiors and/or managers of the workplace and/or the Machine of any faults, subsidence, deterioration of any other fault that could cause the Radio Remote Control and/or the Machine to malfunction or that could injure Persons and/or damage property;
- not use the Radio Remote Control if it is damaged or if the controls are not working correctly;
- use the Machine on which the Elca Radio Remote Control is installed only in safe conditions and only if it is possible to get a good view of the working area of the Machine;

### 8.7 Classification of the controls

This paragraph describes the classification of the controls in the Radio Remote Control: this information is useful during installation and maintenance.

#### Type of control: analogue or digital

The commands sent by the Transmitting Unit can be either analogue or digital.

An analogue command generates a proportional output depending on the position of the relative actuator.

A digital command switches the state of the relative output according to the position of the corresponding output. This state can be on or off.

#### Name of the commands

All the commands sent by the Transmitting Unit are identified with initials.

These initials are reported in the Position of the controls and in the Connection diagram to be used during installation.

These documents clarify the correspondence between the commands sent by the Transmitting Unit and those available in the Receiving Unit.

### 8.8 Training of the personnel: Installation and maintenance

All the installation and maintenance operations on the Elca Radio Remote Control should be carried out ONLY by qualified personnel. Without limiting the foregoing, the qualified technical personnel should be trained and qualified in relation to:

- the work to be carried out;

- use the Machine on which the Elca Radio Remote Control is installed only in accordance with the measures and instructions provided by the Manufacturer of the Machine and in compliance all applicable Laws, Regulations and Standards, also local;
- turn off the Transmitting Unit whenever work is suspended, even momentarily;
- respect all the instructions and warnings provided by the Manufacturer of the Machine and/or the Installer;
- respect all the instructions and warnings provided by the person responsible for starting up the Machine for work;
- respect all the instructions and warnings contained in the Manual of the Radio Remote Control;
- use the Radio Remote Control only as described in this Manual, as explained in all the warnings and instructions provided by Elca and in any event not contrary to all the applicable Laws, Regulations and Standards, also local;
- be aware of its work application and as a consequence implement all the operating instructions received in relation to that;
- use the Radio Remote Control only if in a good mental and physical condition;
- use the Radio Remote Control to move the Machine correctly;
- use the Transmitting Unit gripping it with both hands or using support devices (belt, sheath etc.) for the Transmitting Unit supplied by Elca;
- use the stop devices of the Radio Remote Control or the Machine if any dangerous situation arises, also unrelated to the use of the Machine;
- use the transmitting Unit only if there is no risk of falling, loss of control or contact with Persons and/or objects;
- pay attention to the indicator lights of the Transmitting Unit;
- respect any safety distances connected to the use of the Machine in order to avoid potential and/or real situations of risk.

The User should not:

- use the Radio Remote Control if not fully aware of the instructions and warnings of the Radio Remote Control or if no suitable training has been received from qualified personnel;
- use the Radio Remote Control if you suspect a malfunction of the Radio Remote Control, the Machine or a component;
- use the Radio Remote Control if the labels, symbols and/or the warnings are dirty, worn or illegible;
- use the Radio Remote Control in conditions that do not allow the Transmitting Unit and/or the Machine to be controlled correctly;
- use the Radio Remote Control and carry out other operations, like for example using other Machines and/or other devices (telephone, computer, keyboards, information technology or audio-visual appliances, radio-telephone etc.);
- eat or drink when using the Radio Remote Control;
- tamper with the Transmitting Unit, including its components and controls;
- alter the labels, the warnings and everything on the Units panel;
- allow unauthorised persons and/or those who are not adequately trained to use the Radio Remote Control;
- leave the Units exposed to the possibility of being used, damaged or tampered with by unauthorised persons.

**OBSERVE ALL FURTHER INFORMATION, INSTRUCTIONS OR WARNINGS CONTAINED IN THIS MANUAL.**

### 9.3 Environmental conditions of use

The environmental conditions of use of the Elca Radio Remote Control are the following:

Unit	Temperature
Radio Remote Control	from -25°C to +55°C

### 9.4 Warnings before starting work

Before starting work with the Radio Remote Control the User should:

- get in a position that allows both direct control of the Machine and also the movement of the load;
- get in a safe position with respect to the load, the Machine and any other activity, operation of the workplace;
- move to a work position where there is no risk of losing balance or tripping;
- check that the STOP button mechanism is working correctly;
- use the Radio Remote Control only for its intended use or for operating requirements;
- learn the correspondence between the actuators and the operations of the Machine.

The User should not:

- switch on or use the Radio Remote Control in enclosed spaces or places with poor visibility;
- use the Radio Remote Control if it is outside the operating range.

Failure to comply with the points above can lead to a connection between the Units of the Radio Remote Control that is not optimal, with the risk that the Machine carries out undesired commands.

The symbols on the Units panel have been chosen by the Manufacturer of the Machine and/or the Installer based on the use and purpose of the Machine.

### 9.5 Warnings during normal use

During normal use the User should:

- pay attention to the work area and any dangerous situations present;
- visually check all the movements of the Machine and the load;
- stay within the operating range of the Radio Remote Control;
- pay attention to the visual and acoustic signals of the Radio Remote Control;
- use the Radio Remote Control to move the Machine safely, to avoid creating dangerous situations for Persons and/or property;
- switch off the Transmitting Unit and disconnect the power supply to the Receiving Unit in the event of a malfunction;
- immediately notify superiors and/or managers of the workplace and/or the Machine of any malfunctions;
- use the Radio Remote Control only after solving and problems and/or malfunctions;
- use the Radio Remote Control only with a fully charged battery;
- end any dangerous operations as soon as possible in the event of a low battery;
- use any holster, belt for the Transmitting Unit to prevent the Unit falling or accidentally activating the actuators.

### 9.6 Warnings for after its use

Warnings for after its use

- avoid leaving the Machine in dangerous conditions (for example with a suspended load);
- prevent unauthorised or unsuitable trained persons from using the Radio Remote Control.

**FAILURE TO COMPLY WITH THESE INSTRUCTION CAN CAUSE SERIOUS INJURIES OR DEATH AND/OR DAMAGE TO PROPERTY.**

### 9.7 Belt

The transmitting unit and the cable control unit are supplied with a belt.

#### 9.7.1 Shoulder harness

##### Assembly

Before using the Radio Remote Control the User should connect the belt to the Transmitting Unit and/or the cable control unit, as described in the following procedure.

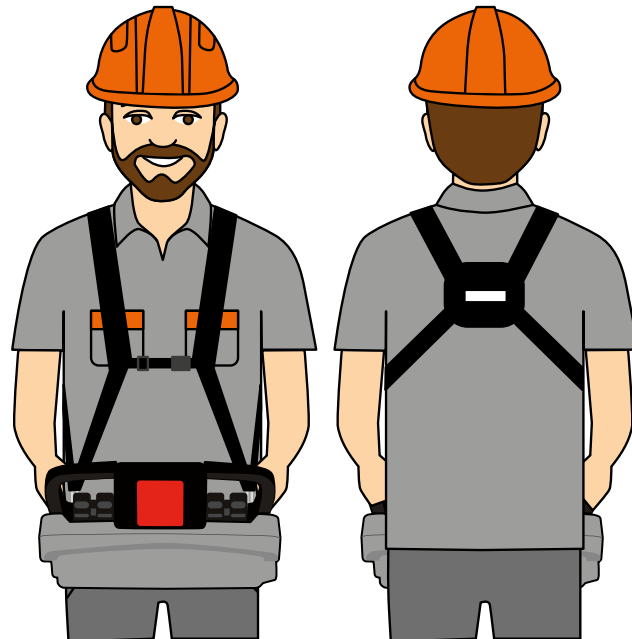
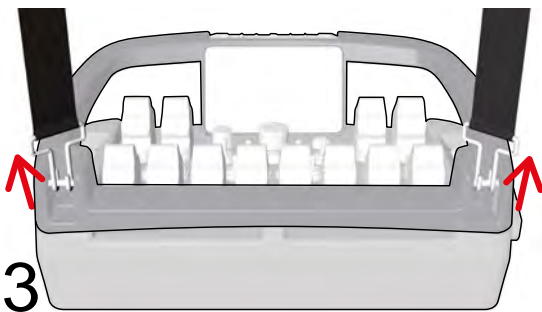
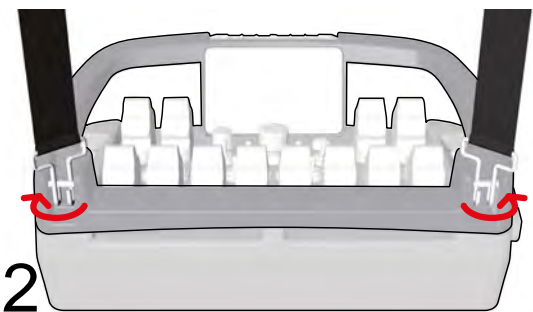
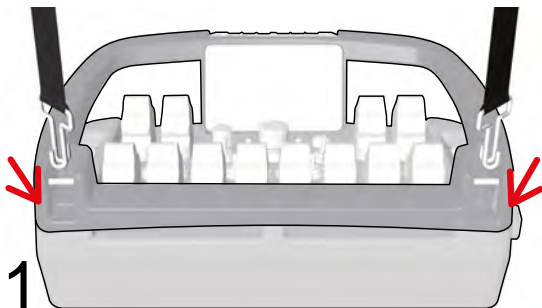

#### 9.7.2 Pouch belt

##### Assembly

Before using the Radio Remote Control the User should connect the belt to the Transmitting Unit and/or the cable control unit, as described in the following procedure.



##### Use

 The User should use the belt with the Transmitting Unit and/or the cable control unit attached to prevent it falling or actuators accidentally being activated.

 The belt should be replaced if it show signs of wear or damage.

 Any other use of the belt constitutes the improper use of the control systems.

4

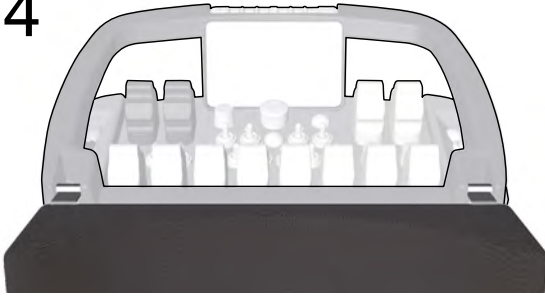

**!**  
The User should use the belt with the Transmitting Unit and/or the cable control unit attached to prevent it falling or actuators accidentally being activated.

**!**  
The belt should be replaced if it show signs of wear or damage.

**!**  
Any other use of the belt constitutes the improper use of the control systems.

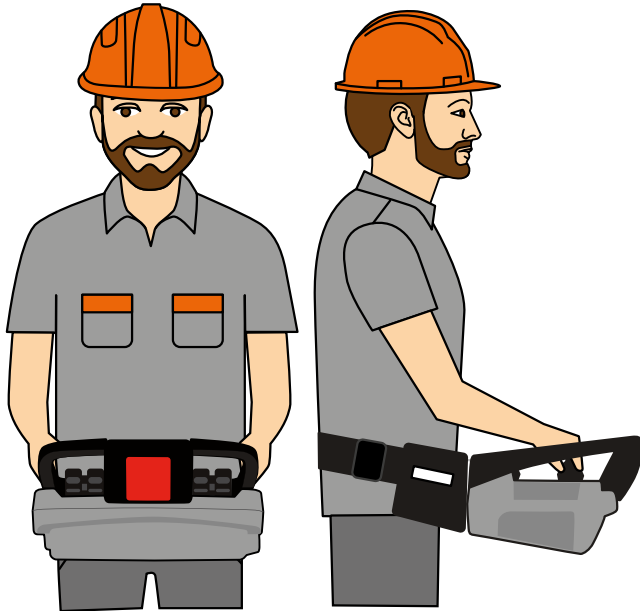

10 Description of the Transmitting Unit

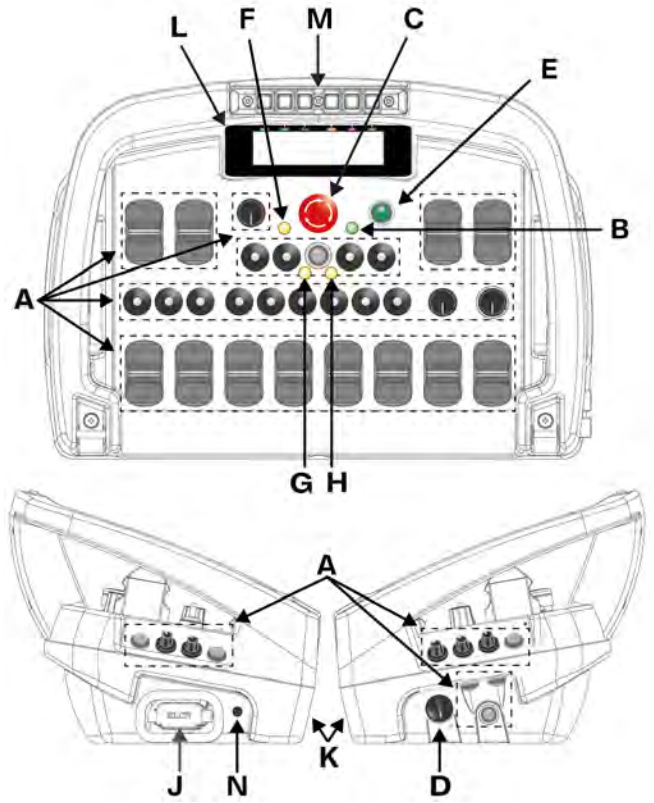

A	Actuators (selectors, buttons, potentiometers, joysticks)
B	LED Check
C	STOP mushroom button
D	Starting keyswitch
E	START button
F	LED Enable clamp
G	LED Pump
H	LED Jet
J	Battery
K	Rating plate
L	4.3" display
M	Display buttons
N	Display programmer connector

**i**  
The Display is customised by the machine manufacturer.

### 10.1 Technical data

Radio transceiver module	RTB-EA3
Antenna	incorporated
Distance between antenna and human body	> 10 mm
Power supply	Li-ion 7.4 V battery
Current draw	<130 mA
Absorbed power	<1 W
RF effective radiated power	<25 mW ERP
Run time with fully charged battery at 20 °C (emissions power 10mW)	up to 10 hours (may vary according to the use of the Display)
Autonomy after "low battery" warning	10 min
Protection degree	IP65
Dimensions	408x202x271 mm
Weight	3500 g

Display	
Size and Colours	TFT LCD, 4.3" - 480x272 pixel - WQVGA 16M colours
Brightness	500 (cd/m2)
Keys	6 programmable

**i** The Radio Remote Control was evaluated for RF Exposure of portable devices.

### 10.2 The Position of the controls and Connection diagram

The documentation supplied with the Radio Remote Control consists of:

- "Arrangement of Controls" that contains the configuration of the Transmitting Unit and the names of the commands sent to the Receiving Unit;
- "Connection diagram" that indicates the correspondence of the commands sent by the Transmitting Unit and those available in the Receiving Unit.

The Position of the controls and the Connection diagram should always remain attached to this Manual: if you have to use one or more of these documents for administrative purposes (controls, tests, etc.) a copy should be made.

### 10.3 Transmitting Unit data plate

The rating plate on the Transmitting Unit AT BRAVO-FUNK+ 915 contains information on: the serial number (Serial Num.), year of manufacture, main technical data on the Transmitting Unit, marking and any marks of the Radio Remote Control.

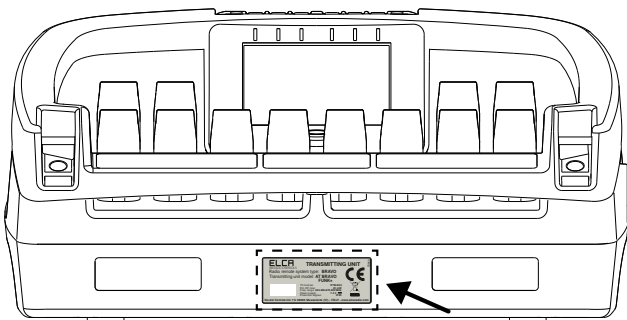

### 10.4 Indicator lights

#### 10.4.1 LED Check



The Check LED may have two colours: green or red. The green or red colour provides information on the radio remote control.

See the tables below for the meaning of the LED lights. For the action to be undertaken when the green and red indicator lights are present see the tables below or paragraph 20.1.

**!** It is not possible to alter the meaning of the green and red LED signals.

SIGNAL	MEANING
The Check LED is off.	The Radio Remote Control is switched off.
The green Check LED flashes slowly.	The Radio Remote Control is operating correctly and the battery is charged.
The green Check LED flashes rapidly.	The Radio Remote Control is on, waiting for START.
The Check LED flashes green rapidly and red slowly.	The battery is low and the radio link is not active.
The Check LED flashes green and red slowly.	The battery is low but the radio link is active.
The red Check LED flashes slowly.	The Radio Remote Control is working correctly but the battery is low (run time left less than 10 min).
The Check LED flashes red once and then switches off.	The Radio Remote Control detects the active Stop button.
The Check LED flashes red twice and then switches off.	The Radio Remote Control detects an active ON/OFF command.
The Check LED flashes red three times and then switches off.	The Radio Remote Control detects the low battery.
The Check LED flashes red four times and then switches off.	The Radio Remote Control detects a joystick out of zero.
The Check LED remains on for two seconds and then switches off.	Faulty transmitter.

**i** When the Red LED that indicates an error or Low Battery goes on, the transmitter emits a sound signal.

#### 10.4.2 LED Enable clamp

The Enable clamp LED remains on when, with selector S13 in the Drilling with Loader position, the Enable button (B34) is pressed.

#### 10.4.3 LED Jet

In Drilling or Drilling with Loader mode, the Jet LED remains on when the Jet output is active.

#### 10.4.4 LED Pump

In Drilling or Drilling with Loader mode, the Pump LED remains on when the Pump output is active.

#### 10.4.5 LED test

The Transmitting Unit runs a functional LED test when, with the battery on, the starting keyswitch is turned to position 1. The LEDs flash rapidly and intermittently; the Check LED flashes green, while the JET / PUMP / ENABLE LEDs flash yellow. Having pressed the START button they switch off, and the Check LED flashes green to indicate that the system is functioning correctly.



# 11 General operating instructions

The radio remote control system BRAVO has been developed to ensure the best operating performance and has some special features outlined below.

The symbols illustrated in this document are indicative and may vary.  
Refer to the specific documentation attached to the radio remote control.

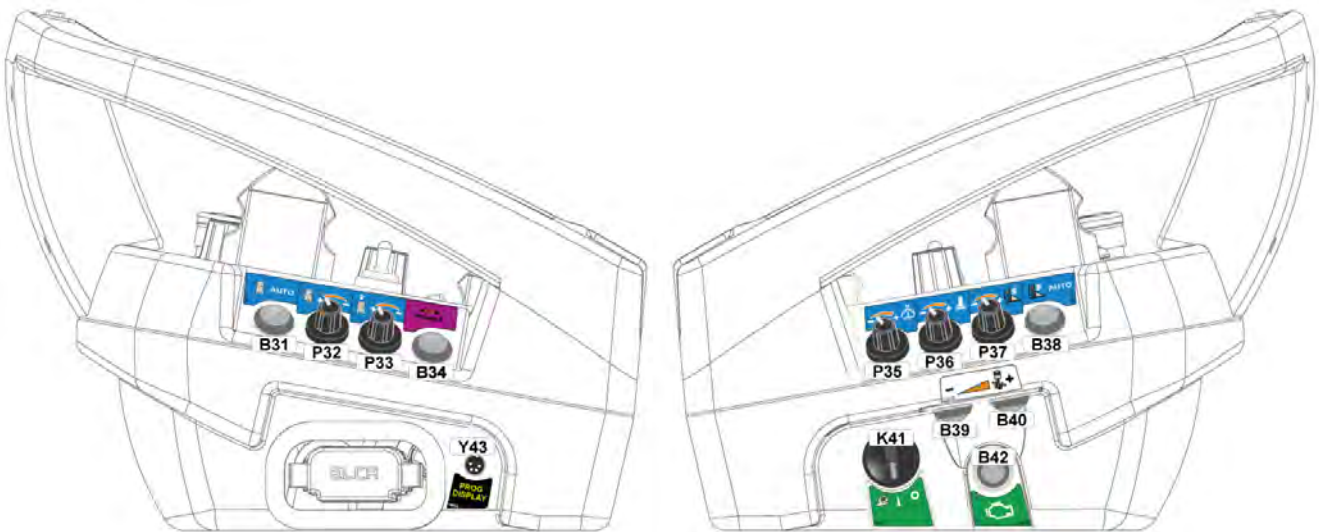
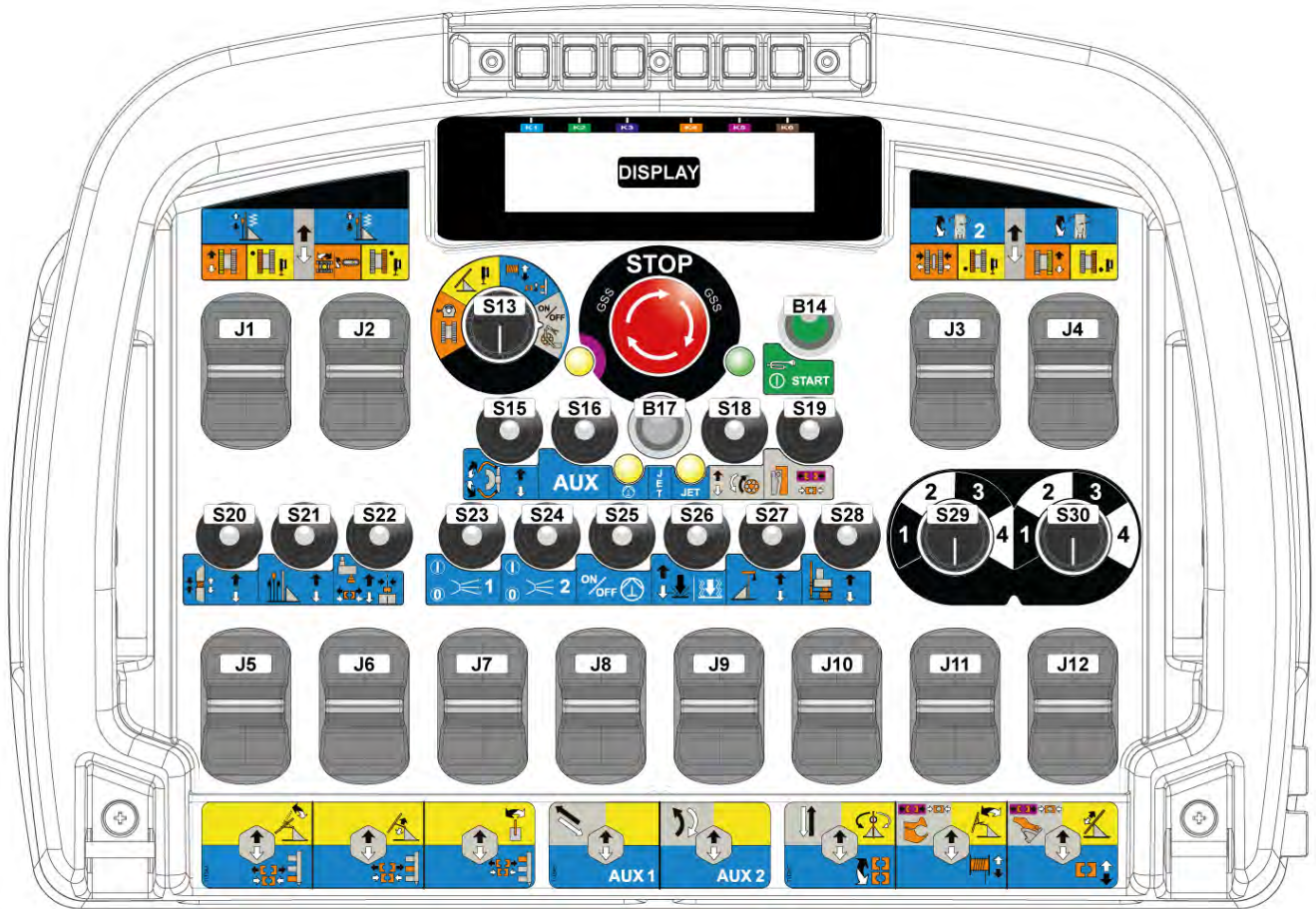

### 11.1 Mechanical starting keyswitch



The transmitting unit has a mechanical starting keyswitch, the radio remote control cannot operate if the key is not inserted in the transmitting unit.

To insert the mechanical key:

- introduce the key inside the relative seat with the index pointing to position 0.

To remove the key:

- turn the key anti-clockwise to position 0;
- pull the key out of the seat.

Remove the mechanical key when the radio remote control is not used or the work is interrupted even for short periods.

#### “Slow” mode

Turning the mechanical key to Slow (At symbol) the belt outputs slow in Movement mode.

The Transmitting Unit does not switch on if the mechanical key is in the Slow position, on Start the Check LED flashes red twice and an acoustic error signal is given.

### 11.2 START command

The START command activates the Transmitting Unit, enables the Receiving Unit and enables the HORN output.



The START command enables the machine operating mode with the system active.

The Transmitting Unit does not switch on if:

- the mechanical key is in the "Slow" position, the Check LED flashes red and an acoustic error signal is given;
- selector S13 is in an operating mode other than Positioning, the LEDs switch on briefly and the Transmitting Unit switches off;
- the STOP button has been pressed;
- one of the ON/OFF commands is active, or one of the joysticks is out of zero.

N.B.: Having pressed START, if the Check LED flashes rapidly the Transmitting Unit is active but the Receiving Unit is not enabled. Press START again to enable the Receiving Unit (Check LED flashes green slowly).

### 11.3 STOP button

The STOP button stops the Machine and switches off the Transmitting Unit.



To restart working after the STOP button was pressed, proceed as follows:

- check that the operating conditions are safe;
- turn the STOP button in the direction indicated to disengage it;
- carry out the procedure for starting the Radio Remote Control (see paragraph 11.5).

If the STOP button has been pressed when starting the Radio Remote Control, the Check LED flashes red once and an acoustic error signal is given.

if a dangerous situation arises press the STOP button to immediately stop the Machine.

It is necessary to check that the Manufacturer of the Machine and/or the Installer provide suitable instructions and warnings in relation to any risks that derive from the stoppage of the Machine. These risks could, for example, come from inertial movements or from the swinging of the load.

### 11.4 Activating the controls

The actuators present on the transmitting unit can be of different types.

They can be:

- toggle switches;
- buttons;
- on/off joystick;
- proportional joystick;
- potentiometer.

For the functions of the various keys on the unit, refer to the command layout attached to the unit itself.

### 11.5 Starting the Radio Remote Control

Starting the Radio Remote Control consists of establishing the radio link between the Transmitting Unit and the Receiving Unit.

To start the radio remote control, insert the key, power the transmitting unit and enable the START command and selector S13 in "Positioning" mode (see paragraphs 11.1 and 11.2). Also refer to the indications in paragraph 7.1.

Turn off the transmitting unit when the radio remote control is not used to operate the machine, or when the work is interrupted in another way, even for short periods.

Use this procedure to start the Radio Remote Control:

- turn the mechanical key to position 1 (LED flashes green rapidly);
- turn selector S13 to Positioning mode;
- check that the STOP button is off;
- press the START command before enabling the display (LED L44 flashes green slowly).

The Transmitting Unit does not switch on if:

- the mechanical key is in the "Slow" position, the Check LED flashes red and an acoustic error signal is given;
- selector S13 is in an operating mode other than Positioning, the LEDs switch on briefly and the Transmitting Unit switches off;
- the STOP button has been pressed;
- one of the ON/OFF commands is active, or one of the joysticks is out of zero.

**11.6 Selecting the operating mode**

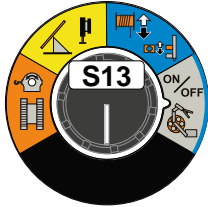

The selector S13 selects the operating mode of the machine. When changing the operating mode, press START to enable it. Upon activation of the radio link with the Receiving Unit, this switch should be in Positioning mode.

**Movement**

Only the functions shown on an orange background and the GAS+, GAS- and STOP motor functions are active in this operating mode. Slow mode functions only in Movement mode. All others are deactivated.

**Positioning**

Only the functions shown on a yellow background and the GAS+, GAS- and START motor functions are active in this operating mode. All others are deactivated.

**Drilling (Operational)**

Only the functions shown on a blue background and the GAS+, GAS- and STOP motor functions are active in this operating mode. All others are deactivated.

**Drilling with Loader**

Only the functions shown on a blue background, on a grey background as a second function (from J8 to J12) and the GAS+, GAS- and STOP motor functions are active in this operating mode. All others are deactivated.

Wait for the display to come on before changing the machine operating mode.

When passing from Drilling operating mode to Loader operating mode, the shared functions (J8 - J12) switch off, press the START button to enable them.

**11.6.1 Clamp opening functions with safety enabled**

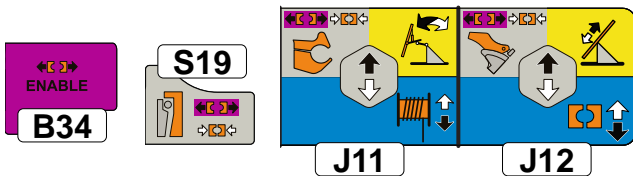

To enable the clamp open function (purple background), press Enable B34, the Enable LED remains on. The selector S19 and the joysticks J11-J12 open the clamps (actuators pushed upwards) protected by a safety enable command. The clamp close command does not require the enable command. In other radio remote control applications, some drilling functions may require safety enabling. Refer to the layout.

**11.7 Special functions in Drilling mode (operational)**

The special functions in Drilling mode are:

- gate open mode;
- gate closed mode;
- special function mode.

Each change of drilling mode disables the joysticks from J1 to J4, press the START command to enable them.

When passing to Drilling with Loader operating mode, the automatic devices remain active.

When none of the drilling modes are enabled, joysticks J1, J2, J3, J4 are disabled.

**11.7.1 Gate open mode**

In Gate open mode, the joysticks from J2 to J4 run in slow mode, while J1 does not run. The remaining joysticks run in normal mode.

**11.7.2 Gate closed mode**

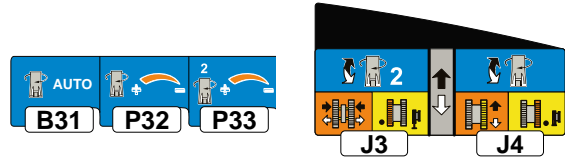

In Gate closed mode, the joysticks from J1 to J4 run in normal mode, and some automations are enabled.

To enable the automatic rotation of Rotary 1 (clockwise rotation), move the joystick J4 upwards and press button B31 or B38, then release J4.

The automatic rotation is now active and it is possible to vary the rotation speed of Rotary 1 by means of potentiometer P32.

To disable the automatic rotation function, move the joystick J4 out of zero. Now the rotation control has returned to the joystick.

To enable the automatic rotation of Rotary 2 (clockwise rotation), move the joystick J3 upwards and press button B31 or B38, then release J3.

The automatic rotation is now active and it is possible to vary the rotation speed of Rotary 2 by means of potentiometer P33.

To disable the automatic rotation function, move the joystick J3 out of zero. Now the rotation control has returned to the joystick.

When exiting Drilling mode, all the automatic devices are cancelled.

**Pull, Push and Rapid function**

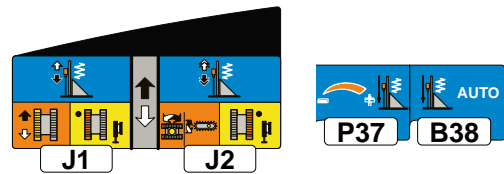

To enable the automatic Push function, move the joystick J1 upwards and press button B31 or B38, then release J1.

The adjustment of the thrust force is made using potentiometer P37.

To enable the automatic Pull function, move the joystick J1 downwards and press button B31 or B38, then release J1.

The thrusts force is always maximum whatever the position of the potentiometer P37.

Joystick J2 enables the Rapid pull and push functions. In some Radio Remote Control applications the Rapid function slows the Rotary 1 and Rotary 2 functions.

When exiting Drilling mode, all the automatic devices are cancelled.

**11.7.3 Special function mode**

The special function mode can be enabled in gate open mode.

Joystick automations are enabled as described in paragraph 11.7.2, but at least one of the joysticks J1-J3-J4 must be moved out of zero to keep the automatic function active.

When joysticks J1, J3, J4 are in the rest position, the automatic devices are disabled.

When exiting Drilling mode, all the automatic devices are cancelled.

### 11.8 Relationships between joysticks

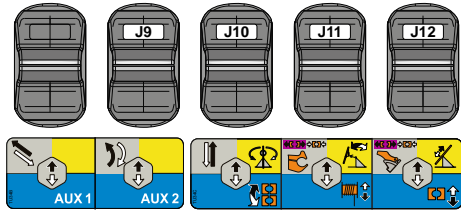

Some Joysticks are placed in relation to each other and are:

- J9 - J11 cannot perform both functions simultaneously and J11 has priority over J9;
- J10 - J12 cannot perform both functions simultaneously and J12 has priority over J10.

### 11.9 Machine motor command



To switch off the motor press button B42.  
 To switch the machine motor on position selector S13 in Positioning mode.  
 Press and hold down button B42 for the whole motor START sequence. With B42 active, give an impulse to the START command, after around 5 seconds the motor START command is enabled. Release B42 when the motor has started. The green Check LED flashes.

### 11.10 Jet Command



The Jet command is enabled by pressing button B17 (push-push command), the Jet LED remains on once enabled.  
 To exit Jet mode press button B17. When selector S13 is in an operating mode other than Drilling, the Jet command is disabled.

### 11.11 "GEAR" command

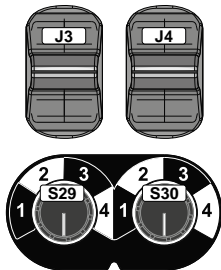

Selector S29 controls GEAR 2, Rotary 2 gear change.  
 Selector S30 controls GEAR 1, Rotary 1 gear change.

### 11.12 Pump Command

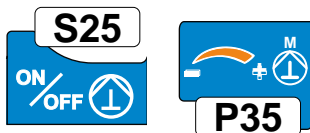

The Pump command is enabled with selector S25 (push-push command).  
 An impulse enables the Pump command, the Pump LED remains on.  
 To adjust the speed use potentiometer P35.  
 To exit Pump mode, give an impulse to S25 or exit the Drilling operating mode.

### 11.13 Hammer Command



The Hammer command is enabled with selector S26 (push-push command), and has two operating modes:

- ON/OFF mode;
- Slow/ON/OFF mode.

In ON/OFF mode, an impulse enables the hammer command and an impulse switches it off. To adjust the strength use the potentiometer P36.

In Slow/ON/OFF mode, an impulse enables the defined slow mode, a second impulse activates the hammer command and a third impulse switches it off. To adjust the strength use the potentiometer P36.

Press selector S26 to Vibration mode (downwards) to switch off Hammer mode, and vice versa.

### 11.14 Anti-tip function

The anti-tip function is enabled when during the operating activity the Transmitting Unit exceeds a 60° angle compared to the position the Transmitting Unit assumes when placed on a horizontal surface. The green Check LED flashes rapidly twice and the Transmitting Unit is switched off.

### 11.15 Activating the controls

Once the Radio Remote Control has been started it is possible to start the buttons for the controls of the Machine.  
 It is the responsibility of the Installer and/or the Manufacturer of the Machine to choose the functions and the symbols of the buttons of the Transmitting Unit and it is always their duty to provide these instructions with the Machine so that the User is well informed on this matter.

### 11.16 Interruption of the radio link

If for any reason the radio link is incorrect or interrupted, use the automatic stop function (see paragraph 8.2.4).

### 11.17 Charging the Transmitting Unit

The table below indicates the signals regarding the charge state of the Transmitting Unit.

SIGNAL	MEANING
The green LED flashes slowly ( 1 flash/second).	The Transmitting Unit is charged.
The Check LED flashes red rapidly and green slowly.	The Transmitting Unit has a low battery (10 minutes of run time).

To charge the Transmitting Unit see chapter 12 .

### 11.18 Switching off of the Transmitting Unit

If the Transmitting Unit needs to be switched off, simply press the STOP button, or turn the key anticlockwise to bring it to position "0".

If the Radio Remote Control is not used to control the Machine, the Transmitting Unit should be switched off, preventing access by removing the mechanical key from the key lock. Switch off is necessary also when the work is interrupted also for brief periods.

Do not leave the load suspended or the Machine in a dangerous condition (also when charging the Unit or changing the battery).

**FAILURE TO COMPLY WITH THESE INSTRUCTION CAN CAUSE SERIOUS INJURIES OR DEATH AND/OR DAMAGE TO PROPERTY.**

**11.19 Replacing the Transmitting Unit**

If the Transmitting Unit is no longer usable, it can be replaced with a new identical Transmitting Unit, which can be requested from Elca.



The replacement operations should only be carried out by qualified personnel and only in the maintenance phase with the machine stopped in safety conditions.

The replacement procedure allows you to uniquely connect a new Transmitting Unit with a Receiving Unit. In compliance with IEC60204-1 and IEC60204-32 that establish that just one Transmitting Unit can control the machine at the same time, at the end of this procedure the Transmitting Unit that was previously connected to the Receiving Unit is no longer recognised. Therefore only the new Transmitting Unit will be able to control the Machine, taking the place of the previous one. At the end of the replacement procedure always check that the new Unit is operating correctly, making sure that all the movements are executed correctly and in particular the STOP function.



Remove the data plate from the transmitter that is no longer used and fix it to the new one. If this is not possible because it is lost, destroyed or illegible, contact an ELCA Assistance Centre for a new one.

**12 Charging system of the Transmitting Unit**

There is a seat on the Transmitting Unit for the rechargeable battery that can be removed. The battery charges with the charging device (battery charger) supplied with the Elca Radio Remote Control.

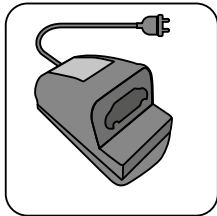

Only recharge the batteries when necessary. The battery should be charged in a place where the temperature is between 0°C and 40°C; this ensures maximum performance in terms of charging capacity and useful life of the battery. The charging process stops outside this temperature range and the Charge LED flashes. Recharging will automatically resume when the temperature is within the above mentioned temperature range.

**12.1 Instructions for use**



Use only original Elca batteries and recharge them only with the Elca charging system.

Do not use batteries showing external damage.

Do not short circuit the battery contacts.

Do not tamper with or attempt to modify, open, perforate or repair the battery in any way.

Do not wet the battery with any liquid.

Do not put the battery in high pressure containers.

Do not knock or drop the battery.

Do not put the battery in your mouth.

Do not store the battery in bags or pockets containing metal objects that could cause short circuits with the risk of burns.

Do not expose the battery to long periods of heat or sunlight.

Pay attention to the high temperatures that may be generated inside vehicles exposed to the sun.



The charging system is for professional use, therefore it can only be used by competent personnel or by suitably trained persons.

The charging system cannot be used by a Person with limited physical, sensory and mental abilities and by children.

The charging system should not be used with wet or damp hands or feet. The use of the charging system does not require any special tools. In any case, do not for any reason use objects and/or tools that are not insulated since they could conduct electricity.

Before charging the Transmitting Unit always make sure it is undamaged and the contacts are clean both on the Unit and also on the charger.

If cleaning is required, the charging system must be disconnected from the power supply.

If the battery seat on the Transmitting Unit has to be cleaned, disconnect the Transmitting Unit from the power supply.

Use a damp cloth with a cleaner for the electric contacts or a non-abrasive brush.

Protect the charging system from dust and material like lime, sand, concrete or other substances.

Be very careful when using the charging system, since it can be a source of fire, overheating and other dangers.

Elca declines all responsibility for any improper or unreasonable use of the battery or in any case that does not comply with this Manual.

**12.2 Charging system technical data**

Battery charger model	LITE-ION-D / LITE-ION-R
Power supply	12-30 V <sup>===</sup>
Current draw	< 1 A
Rated output voltage	8.4 V <sup>===</sup>
Rated output current	1,0 A
Protection degree	IP40
Dimensions	144x84x92 mm
Weight	300 g

Power unit	LITE-ION USA
Input	100-240Vac 50/60Hz 450mA
Output	12V= 1.5A (18W)
Plug	USA Plug Type A (NEMA 1-15)
Dimensions	59.3x30.7x75.6 mm
Weight	120 g

**12.3 First aid**



Consult a doctor immediately if a battery or part of it has been ingested.

In the event that a Person comes in contact with material that has leaked from a damaged battery, immediately wash the affected area with soap and water for at least 15 minutes and consult a doctor as soon as possible.

### 12.4 Battery storage

Please note that a battery will self-discharge over time if not used; prolonged storage can also lead to a total and definitive loss of capacity, making the battery unusable.

In order to ensure maximum battery life over time, the battery should be stored in a cool and dry environment if a long period of non-use is expected.

The following table shows the residual capacity of the battery with respect to the nominal value, depending on the storage temperature and duration.

Temperature	Duration
from 45 to 60°C	1 month
from 25 to 45°C	3 months
from -20 to 25°C	1 year

The table is indicative in the case of a battery stored at half-charge, an ideal condition for storage.

### 12.5 Charging indicator lights

SIGNAL	MEANING
The POWER LED is on.	The battery charger is properly powered.
The CHARGE LED is on.	Battery charging in progress.
The CHARGE LED flashes.	Room temperature outside of the permitted range. Charging interrupted.
	Room temperature within the permitted range. The battery could be damaged, replace it and check if the signal returns again.
The CHARGE LED is off.	The battery has reached the maximum charge level, the battery charger assumes charge status maintenance setup.

The full charging process lasts about 4 hours.

The lithium polymer batteries allow a rapid charging process in the initial part of charging.

Two hours charging provides 75% of a full charge, the equivalent of about 6 hours run time, while a charge of just 20 minutes provides about 1 hour of run time.

It is advisable to always keep the batteries fully charged to be able to ensure full effectiveness.

Avoid leaving the batteries discharged for long periods.

Charge the batteries at least once a year.

### 12.6 Battery removal

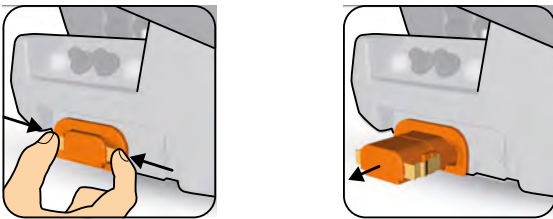

To remove the battery from the seat on the Transmitting Unit:

- open the protective cover;
- press the metal battery tabs;
- remove the battery;
- close the cover.

Always keep the protective cover on the battery seat closed to prevent dust and other materials from entering.

### 12.7 Connection to the charging system

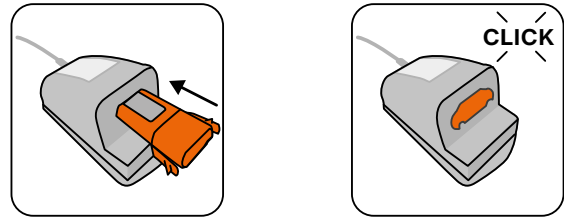

To connect the battery to the charging system:

- open the protective cover (where present);
- insert the battery;
- press the battery fully in (click);
- close the cover (where present).

Check that the electrical connection poles are clean and dry before connecting the charging system.

### 12.8 Removal from the charging system

To remove the battery from the charging system:

- open the protective cover (where present);
- press the metal battery tabs;
- remove the battery;
- close the cover (where present).

### 12.9 Battery introduction

To insert the battery in the seat on the Transmitting Unit:

- open the protective cover;
- insert the battery;
- press the battery fully in (click);
- close the cover.

### 12.10 Disposal of batteries

Do not throw the batteries into a fire as they may explode. Do not dispose of batteries together with household waste.

Batteries may release toxic substances harmful to humans, animals and plants and contaminate the environment. They should be not disposed of with municipal solid waste but delivered to authorised collection centres for battery recycling and treatment.

The crossed-out wheeled bin symbol on the batteries means that the batteries must be disposed of separately from household waste in compliance with Directive 2006/66/EC and subsequent amendments and with local regulations.

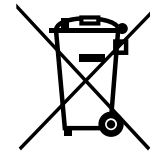

## 13 Description of the Receiving Unit

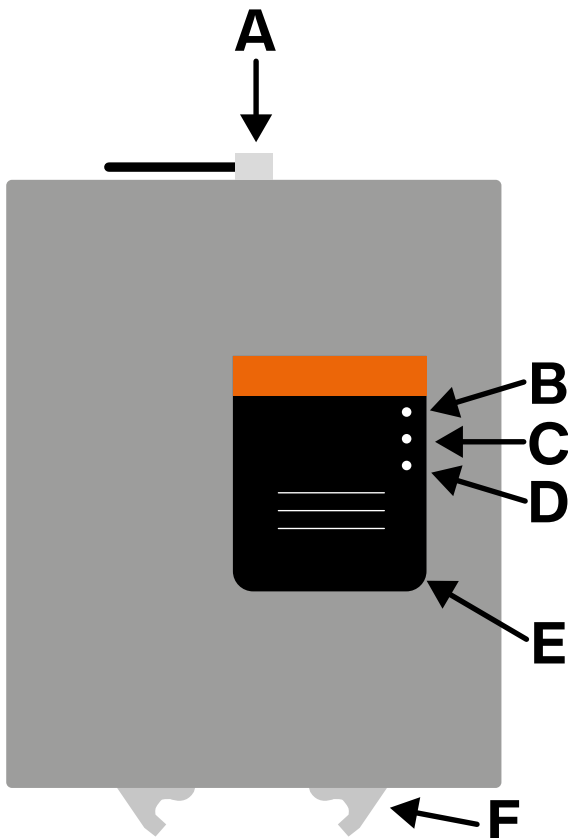

A	Antenna
B	Power LED
C	Alarm LED
D	Status LED
E	Rating plate
F	Plug

### 13.1 Technical data

Radio transceiver module	RTB-EA3
Antenna	dedicated external
Distance between antenna and human body	> 20 cm
Power supply	8-30 V <sup>===</sup>
Current draw	1,0 A
Absorbed power	<5 W
Power supply input protection fuse	F2 = 7,5 A
STOP contacts protection fuses	F3, F4 = 7,5 A
SAFETY contacts protection fuses	F5 = 7,5 A / F1 = 3,0 A
Maximum capacity proportional outputs in current (PWM)	2 A (30 V <sup>===</sup> )
Maximum capacity of ON/OFF outputs	2 A (30 V <sup>===</sup> )
Maximum capacity proportional outputs in voltage	10 mA (28 V <sup>===</sup> )
Maximum contact voltage	30 V <sup>===</sup>
Protection degree	IP65
Dimensions	230x280x110 mm
Weight	5000 g

The Radio Remote Control was evaluated for RF Exposure of portable devices.

EN

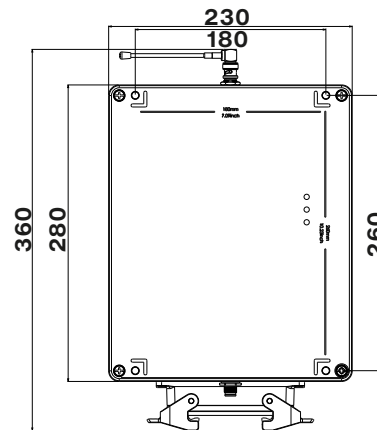

### 13.2 Receiving unit data plate

The rating plate on the cover of the Receiving Unit AR BRAVO-FUNK+ 915 contains information on: the serial number (Serial Num.), year of manufacture, main technical data on the Transmitting Unit and marking of the Radio Remote Control (see image in chapter 13).

### 13.3 Indicator lights

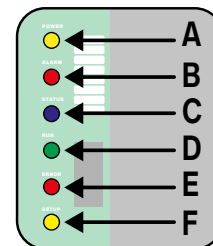

There are LED on the Receiving Unit that allow you to check the operating status.

The externally visible LEDs are:

- the POWER LED [A] (green);
- the ALARM LED [B] (red);
- the STATUS LED [C] (blue).

The visible LEDs when removing the cover from the Receiving Unit are:

- the RUN LED [D] (green);
- the ERROR LED [E] (red);
- the SETUP LED [F] (yellow).

The meaning of the LED coming on is described in the tables below.

#### 13.3.1 POWER LED

SIGNAL	MEANING
The POWER LED is off.	The Receiving Unit is not powered.
The POWER LED flashes slowly.	The radio link with the Transmitting Unit is present.
The POWER LED is on.	The Receiving Unit is powered, but there is no radio link with the Transmitting Unit.

#### 13.3.2 ALARM LED

SIGNAL	MEANING
The ALARM LED is off.	No abnormal condition.
The ALARM LED flashes once a second.	Error in the STOP channels.
The ALARM LED flashes twice a second.	Error in the SAFETY channel.
The ALARM LED is on and steady.	The Receiving Unit is not working properly.

### 13.3.3 STATUS LED

SIGNAL	MEANING
The STATUS LED is off.	The Receiving Unit is not active.
The STATUS LED flashes slowly.	There is a power supply voltage greater than the required one.
The STATUS LED flashes quickly.	The Receiving Unit is receiving data from the Transmitting Unit.

### 13.3.4 RUN LED

The RUN LED signals the communication status of the Receiving Unit with the CAN network.

### 13.3.5 ERROR LED

The ERROR LED signals CAN communication errors.

### 13.3.6 SETUP LED

The SETUP LED has reserved use.



The SETUP button is reserved for authorised qualified personnel.

Failure to comply with these instructions can cause serious injuries or death and/or damage to property.

## 14 General operating instructions

The receiving unit AR BRAVO-FUNK+ 915 consists of the following main circuits:

- MOTHER BOARD
- RADIO RECEIVING MODULE
- BOARD WITH THE IDENTIFICATION CODE
- DATA MEMORY CARD
- LED CARD
- COMMANDS EXPANSION CARDS

### 14.1 Mother Board

This contains the electronics for the decoding and implementation of the controls, the safety fuses, and backs up the radio module, the encryption key, the data memory and the expansion cards.

### 14.2 Radio receiving module

Contains all the electronics for the reception and management of the working frequency.

### 14.3 Board with identification code

It contains the unique identification code of the system. This code allows the system to only recognise the signals transmitted from the transmitter having the same identification code.

### 14.4 Data Memory Card

Contains all the parameters for the adjustment of the proportional outputs inside it.

### 14.5 LED card

Backs-up the signalling LED to monitor the system.

### 14.6 Commands expansion cards

The proportional expansion cards increase the number of proportional commands available.  
The ON/OFF expansion cards increase the number of ON/OFF commands available.

### 14.7 DIP switch

The DIP switches modify the device operation.



The positions of the DIP switches do not need to be changed for any reason during normal use.

The positions of the DIP switches can be modified in certain situations only by suitably trained and qualified technicians.

## 14.8 Command outputs

For the correspondence between the output activated on the Receiving Unit by a command given by the Transmitting Unit refer to the Position of Controls and the Connection Diagram.



## 15 Description of cable control unit

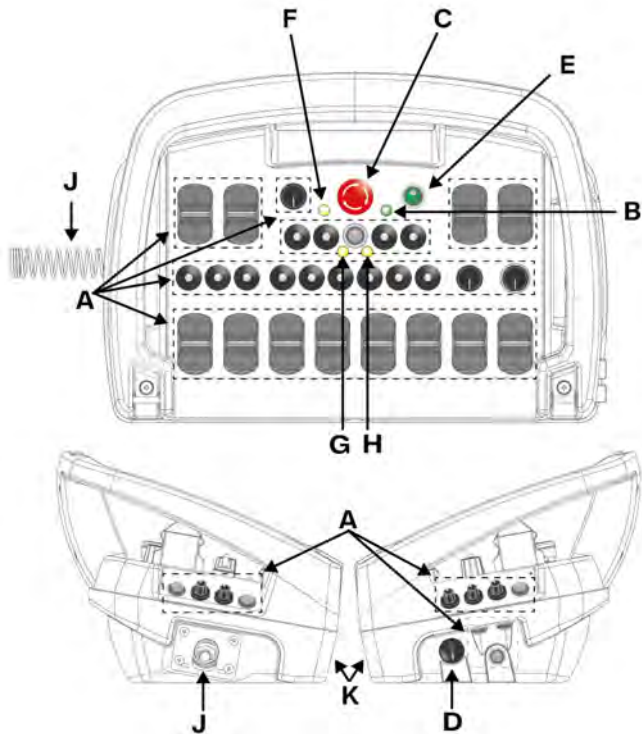

A	Actuators (selectors, buttons, potentiometers, joysticks)
B	LED Check
C	STOP mushroom button
D	Starting keyswitch
E	START button
F	LED Enable clamp
G	LED Pump
H	LED Jet
J	Cable gland
K	Rating plate

### 15.1 Technical data

Power supply	24 V
Current draw	0,35 A
Absorbed power	< 10 W
Protection degree	IP65
Dimensions	408x202x271 mm
Weight	4000 g

### 15.2 Cable control unit data plate

The rating plate on the cable control unit TEL BRAVO-FUNK+ contains information on: the serial number (Serial Num.), year of manufacture, main technical data on the cable control unit and marking on the cable control unit.

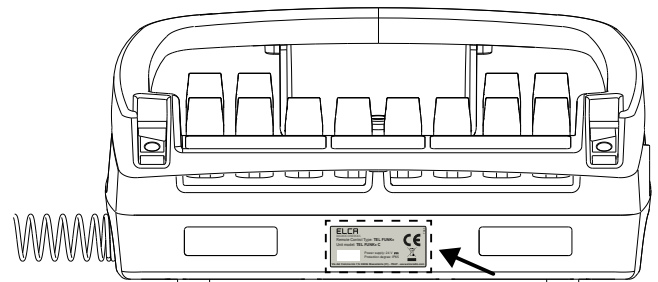

### 15.3 Indicator lights

#### 15.3.1 LED Check



The Check LED may have two colours: green or red. The colour - green or red - provides information about the cable control unit.

See the tables below for the meaning of the LED lights.

For the action to be undertaken when the green and red indicator lights are present see the tables below or paragraph 20.3 .

SIGNAL	MEANING
The Check LED is off.	The cable control unit is switched off.
The green Check LED flashes slowly.	The cable control unit is working properly.
The green Check LED flashes rapidly.	The cable control unit is running the functional LED test.
The Check LED flashes green rapidly and the red fixed.	The cable control unit detects an active ON/OFF command, or a joystick out of zero, or selector S13 is in a position other than Positioning on start-up.

#### 15.3.2 LED Enable clamp

The Enable clamp LED remains on when, with selector S13 in the Drilling with Loader position, the Enable button (B34) is pressed.

#### 15.3.3 LED Jet

In Drilling or Drilling with Loader mode, the Jet LED remains on when the Jet output is active.

#### 15.3.4 LED Pump

In Drilling or Drilling with Loader mode, the Pump LED remains on when the Pump output is active.

#### 15.3.5 LED test

The cable control unit runs a functional LED test when the starting keyswitch is turned to position 1 and START is pressed. The LEDs flash rapidly and intermittently; the Check LED flashes green and red, while the JET / PUMP / ENABLE LEDs flash yellow. After 3 start-up sequences, the LEDs go out. The green Check LED flashes slowly.