

Optoma 3D Glasses – Quick Setup Guide

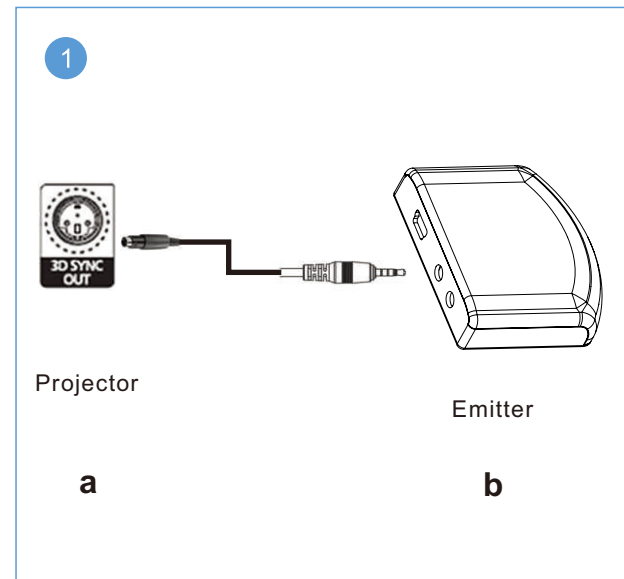

1. Connect emitter to Optoma projector



2. Select VESA in projector OSD

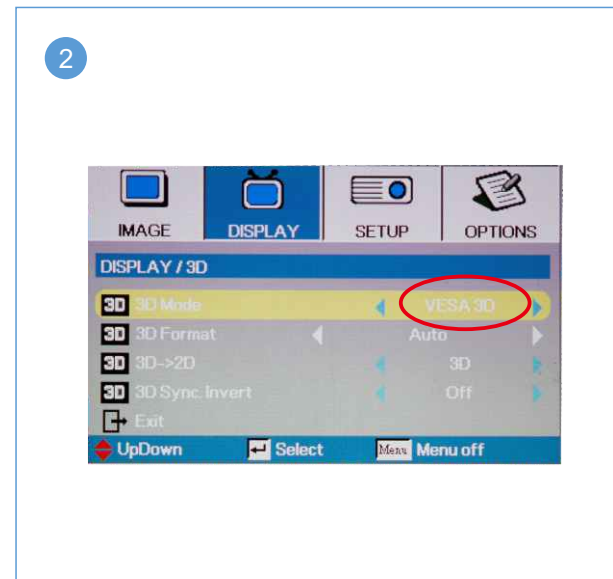

3. Be within the pairing zone

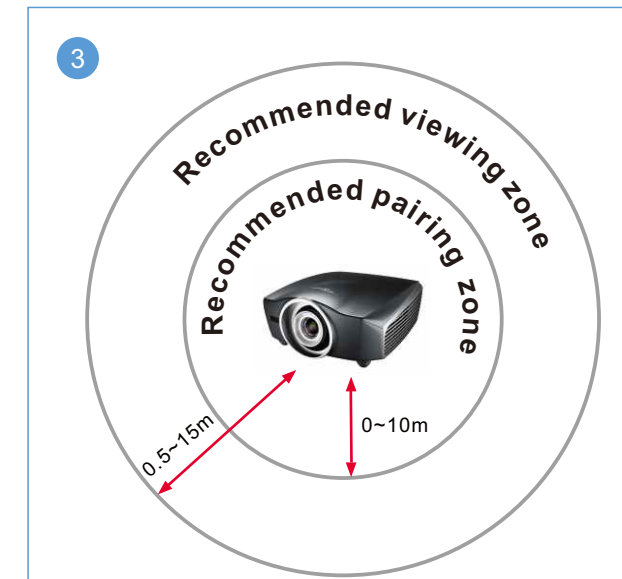

4. Turn on the glasses

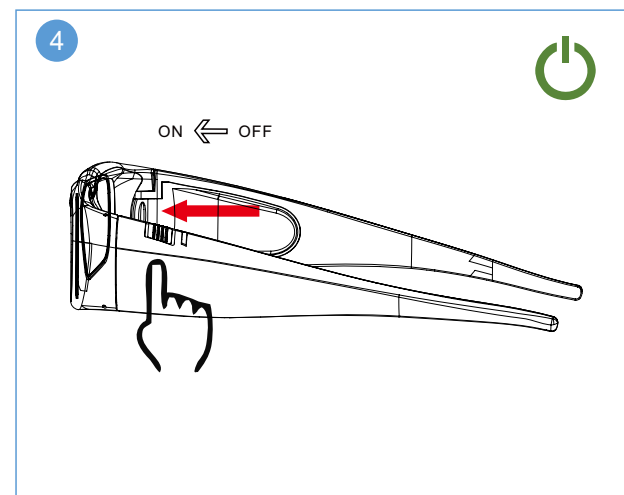

Charging the glasses

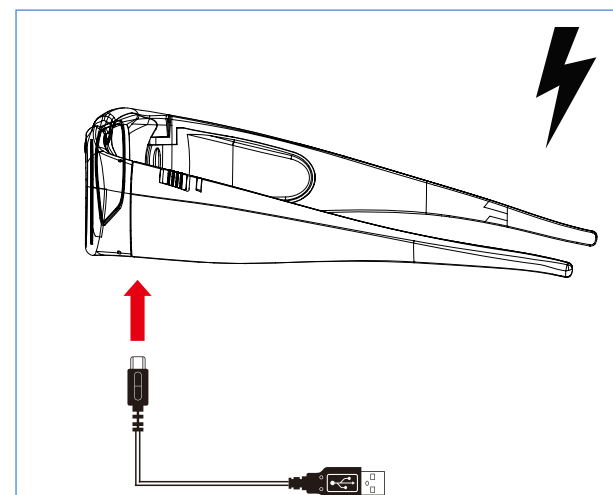

3D Emitter LED Indicator Messages

Searching for 3D signal	Flashing blue
Synced with 3D signal	Solid blue

3D Glasses LCD lens/LED Indicator Messages

Power on/Searching with emitter	Flashing blue
Synced with emitter	Blue led blinks twice and turns off; LCD lens blinks twice
Pairing with emitter	Flashing red and blue
Power off	Red led blinks and turns off
Low Battery	LCD lens blinks twice every 5 seconds before shutting down
Charging	Solid red
Fully charged	Off

Note:

- When using the glasses for the first time, it is recommended to charge the glasses for a minimum of three hours before use.
- When syncing the glasses for the first time, the glasses must be within pairing zone range.

Optoma 3D Glasses – Quick Setup Guide



*English

Optoma 3D Glasses – Quick Setup Guide

- 1.Connect emitter to Optoma Projector
- 2.Select VESA in projector OSD
- 3.Be within the pairing zone
- 4.Turn on the glasses

Note:

- 1.When using the glasses for the first time, it is recommended to charge the glasses for a minimum of three hours before use.
- 2.When syncing the glasses for the first time, the glasses must be within pairing zone range.

*繁體中文

Optoma 3D 眼鏡 - 快速設定介紹

建議您在第一次使用前，至少對3D眼鏡充電三小時以上(使用USB/Mini USB線材充電,充電時眼鏡仍可使用)。

- (1) 使用隨附之線材(一端為2.5mm,另一端為VESA 3-PIN mini DIN)將訊號發射器接駁至投影機後方之"3D SYNC OUT"端子埠。

註：確保連接投影機的訊號來源播放相容的3D影片格式，3D 投影方式必須設定正確。(相容於HDMI 1.4的3D格式一般選擇"自動"即可)。

- (2) 3D訊號發射器搜尋3D訊號過程中，其LED燈號會以藍色閃爍方式呈現；當搜尋到3D 訊號且確認成功後,燈號會固定為藍色。
- (3) 將3D眼鏡上的開關鍵撥至ON位置以打開您的3D眼鏡，眼鏡上的紅色與藍色LED燈會開始交替閃爍。偵測到正確3D 訊號時，即可正常運作&藍色燈號熄滅。

你現在可以順利觀看3D影片

(使用完畢後,請記得對3D 眼鏡充電)

如需更詳細資訊,請至Optoma 網站查詢說明

*Français

Lunettes 3D Optoma - Guide d'installation rapide

- 1.Connec ter l'émetteur au projecteur Optoma
- 2.Sélectionner VESA dans le menu du projecteur
- 3.Se placer dans la zone de synchronisation
- 4.Allumer les lunettes

Recharger les lunettes

Note:

- 1.Avant la première utilisation des lunettes, il est recommandé de les charger pendant au moins trois heures.
- 2.Lors de la première synchronisation des lunettes avec le projecteur, les lunettes doivent être dans la zone de synchronisation.

Pour plus d'instructions, veuillez consulter le site internet Optoma : www.optoma.com

*简体中文

Optoma 3D 眼镜 - 快速设定指南

建议您在第一次使用前,至少对3D 眼镜充电三小时以上(使用USB/Mini USB 线材充电, 充电时眼镜仍可使用)。

- (1) 使用附赠线材(一端为2.5mm,另一端为VESA 3-PIN mini DIN)将信号发射器接至投影机后方的"3D SYNC OUT"端口处。

注：确保连接投影机的信号来源播放兼容的3D影片格式，3D投影方式必须设定正确。(兼容HDMI 1.4的3D格式一般选择“自动”即可)

- (2) 在搜索3D信号过程中,发射器上的LED灯将会显示蓝色并且不断闪烁;当搜索到3D信号时,LED将显示为恒定的蓝色。
- (3) 将3D眼镜上的开关键拨至ON位置以打开您的3D眼镜,眼镜上的红色与蓝色LED灯会开始交替闪烁.侦测到正确3D 讯号时,即可正常运作&蓝色灯号熄灭。

你现在可以顺利观看3D 影片了

(使用完毕后,请记住对3D眼镜充电)

如需更详细资讯,请到Optoma官方网站查询相关说明

*Deutsch

Optoma 3D Brille - Schnellstartanleitung

- 1.Schließen Sie den Emitter an den Projektor an.
- 2.Wählen Sie VESA im Menü des Projektors aus.
- 3.Sie müssen sich innerhalb der Reichweite des Signals befinden.
- 4.Schalten Sie die Brille ein.

Aufladen und Synchronisieren der Brille

Hinweis:

- 1.Es wird empfohlen, die Brille vor dem ersten Gebrauch für mindestens 3 Stunden zu laden.
- 2.Bei der Synchronisation müssen Sie sich innerhalb der Reichweite des Signals befinden.

Für weitere Informationen besuchen Sie bitte die Optoma Website: www.optoma.com

*한국어

Optoma 3D 안경- 빠른 설정 가이드

처음 3D 안경을 사용할 시, 먼저 3D 안경을 최소한 3시간 동안 충전하십시오. (USB / 미니 USB 케이블을 사용하여 충전하십시오. 충전 상태에서 안경은 여전히 사용이 가능합니다.)

- (1) 제공된 케이블(2.5mm jack / VESA 3-PIN mini DIN)을 사용하여 이터와 프로젝터 뒤면의 '3D SYNC OUT' 포트에 연결하십시오.

주의사항: 프로젝터 호환되는 3D 소스에 연결하십시오. 3D 투사 방식이 정확한지 확인하십시오. (HDMI 1.4에 3D 콘텐츠가 제공되면 일반적으로 '자동'을 선택하십시오.)

- (2) 3D 신호를 검색하는 동안 이터에 있는 LED가 깜빡임으로 깜박입니다. 3D 신호가 감지되면, LED는 깜빡임으로 고정됩니다.

- (3) 전원 스위치를 오프에서 온으로 전환하여 3D 안경을 켜십시오. LED가 깜빡임과 적색 교대로 깜박입니다. 3D 신호가 감지되면 깜빡임 LED가 꺼집니다.

이제 3D 영상을 감상할 수 있습니다.

(사용 완료 후, 3D 안경을 충전하는 것을 잊지 마세요.)

더욱 상세한 정보는 Optoma 웹사이트를 이용해 주십시오.

*Español

Gafas 3D Optoma- Guía rápida de puesta en marcha.

- 1.Conecte el emisor al proyector Optoma
- 2.Seleccione VESA en el menú OSD del proyector
3. Póngase dentro de la zona de cobertura del emisor
4. Encienda las gafas

Póngase las gafas

Nota:

- 1.Cuando use las gafas por primera vez, es recomendable un mínimo de 3 horas de carga previa, asegúrese de estar dentro del área de influencia del emisor.
- 2.Para conseguir el manual de instrucciones completo.

Para conseguir el manual de instrucciones completo, por favor visite nuestra web www.optoma.com

FCC Notice:

This device complies with Part 15 of the FCC Rules. Operation is subject to the following two conditions: (1) This device may not cause harmful interference. (2) This device must accept any interference received, including interference that may cause undesired operation.

NOTE: This equipment has been tested and found to comply with the limits for a Class B digital device, pursuant to Part 15 of the FCC Rules. These limits are designed to provide reasonable protection against harmful interference in a residential installation. This equipment generates uses and can radiate radio frequency energy and, if not installed and used in accordance with the instructions, may cause harmful interference to radio communications. However, there is no guarantee that interference will not occur in a particular installation. If this equipment does cause harmful interference to radio or television reception, which can be determined by turning the equipment off and on, the user is encouraged to try to correct the interference by one or more of the following measures:

- Reorient or relocate the receiving antenna.
 - Increase the separation between the equipment and receiver.
 - Connect the equipment into an outlet on a circuit different from that to which the receiver is connected.
 - Consult the dealer or an experienced radio/TV technician for help.
- WARNING:** Changes or modifications not expressly approved by the party responsible for compliance could void the user's authority to operate the equipment.

IC Notice: This device complies with Canada Industry licence-exempt RSS standard(s). Operation is subject to the following two conditions: (1) this device may not cause interference, and (2) this device must accept any interference, including interference that may cause undesired operation of the device. This device complies with RSS-310 of Industry Canada. Operation is subject to the condition that this device does not cause harmful interference.

Le présent appareil est conforme aux CNR d'industrie Canada applicables aux appareils radio exem pts de licence L'exploitation est autorisée aux deux conditions suivantes: 1) l'appareil ne doit pas produire de brouillage, et 2) l'utilisateur de l'appareil doit accepter brouillage radioélectrique subi même si le brouillage est susceptible d'encompromettre le fonctionnement, mauvais fonctionnement de l'appareil.