



# FCC RF Test Report

**APPLICANT** : Lyve Minds, Inc.  
**EQUIPMENT** : Set Top Box  
**BRAND NAME** : Lyve  
**MODEL NAME** : BPH01  
**MARKETING NAME** : LyveHome  
**FCC ID** : 2ABQW-BPH  
**STANDARD** : FCC Part 15 Subpart C §15.247  
**CLASSIFICATION** : (DTS) Digital Transmission System

The product was received on Feb. 13, 2014 and testing was completed on Mar. 10, 2014. We, SPORTON INTERNATIONAL INC., would like to declare that the tested sample has been evaluated in accordance with the procedures and shown to be compliant with the applicable technical standards.

The test results in this report apply exclusively to the tested model / sample. Without written approval of SPORTON INTERNATIONAL INC., the test report shall not be reproduced except in full.

Reviewed by: Joseph Lin / Supervisor

Approved by: Jones Tsai / Manager



## SPORTON INTERNATIONAL INC.

No. 52, Hwa Ya 1<sup>st</sup> Rd., Hwa Ya Technology Park, Kwei-Shan Hsiang, Tao Yuan Hsien, Taiwan, R.O.C.

SPORTON INTERNATIONAL INC.

TEL : 886-3-327-3456

FAX : 886-3-328-4978

FCC ID : 2ABQW-BPH

Page Number : 1 of 100

Report Issued Date : Apr. 03, 2014

Report Version : Rev. 01



# TABLE OF CONTENTS

**REVISION HISTORY ..... 3**

**SUMMARY OF TEST RESULT ..... 4**

**1 GENERAL DESCRIPTION ..... 5**

    1.1 Applicant ..... 5

    1.2 Manufacturer ..... 5

    1.3 Feature of Equipment Under Test ..... 5

    1.4 Product Specification of Equipment Under Test ..... 6

    1.5 Modification of EUT ..... 6

    1.6 Testing Site ..... 7

    1.7 Applied Standards ..... 7

**2 TEST CONFIGURATION OF EQUIPMENT UNDER TEST ..... 8**

    2.1 Carrier Frequency Channel ..... 8

    2.2 Pre-Scanned RF Power ..... 9

    2.3 Test Mode ..... 11

    2.4 Connection Diagram of Test System ..... 14

    2.5 Support Unit used in test configuration and system ..... 15

    2.6 EUT Operation Test Setup ..... 15

    2.7 Measurement Results Explanation Example ..... 15

**3 TEST RESULT ..... 16**

    3.1 6dB and 99% Bandwidth Measurement ..... 16

    3.2 Output Power Measurement ..... 20

    3.3 Power Spectral Density Measurement ..... 25

    3.4 Conducted Band Edges and Spurious Emission Measurement ..... 29

    3.5 Radiated Band Edges and Spurious Emission Measurement ..... 57

    3.7 AC Conducted Emission Measurement ..... 94

**4 LIST OF MEASURING EQUIPMENT ..... 99**

**5 UNCERTAINTY OF EVALUATION ..... 100**

**APPENDIX A. SETUP PHOTOGRAPHS**



### REVISION HISTORY

REPORT NO.	VERSION	DESCRIPTION	ISSUED DATE
FR421348C	Rev. 01	Initial issue of report	Apr. 03, 2014



### SUMMARY OF TEST RESULT

Report Section	FCC Rule	IC Rule	Description	Limit	Result	Remark
3.1	15.247(a)(2)	RSS-210 A8.2(a)	6dB Bandwidth	$\geq 0.5\text{MHz}$	Pass	-
3.1	-	RSS-Gen 4.6.1	99% Bandwidth	-	Pass	-
3.2	15.247(b)	RSS-210 A8.4	Power Output Measurement	$\leq 30\text{dBm}$	Pass	-
3.3	15.247(e)	RSS-210 A8.2(b)	Power Spectral Density	$\leq 8\text{dBm}/3\text{kHz}$	Pass	-
3.4	15.247(d)	RSS-210 A8.5	Conducted Band Edges	$\leq 20\text{dBc}$	Pass	-
			Conducted Spurious Emission		Pass	-
0	15.247(d)	RSS-210 A8.5	Radiated Band Edges and Radiated Spurious Emission	15.209(a) & 15.247(d)	Pass	Under limit 0.26 dB at 2389.740 MHz
3.7	15.207	RSS-Gen 7.2.4	AC Conducted Emission	15.207(a)	Pass	Under limit 12.70 dB at 0.262 MHz
3.7.5	15.203 & 15.247(b)	RSS-210 A8.4	Antenna Requirement	N/A	Pass	-



# 1 General Description

## 1.1 Applicant

Lyve Minds, Inc.

10001 N. De Anza Blvd, Ste 300 Cupertino, CA 95014

## 1.2 Manufacturer

FIH Mobile Limited

No. 4, Mingsheng St., Tu-Cheng Dist., New Taipei City 23679, Taiwan

## 1.3 Feature of Equipment Under Test

Product Feature	
Equipment	Set Top Box
Brand Name	Lyve
Model Name	BPH01
Marketing Name	LyveHome
FCC ID	2ABQW-BPH
EUT supports Radios application	WLAN 11a/b/g/n (HT20/HT40) WLAN 11ac (VHT20/VHT40/VHT80) Bluetooth v2.1 + EDR Bluetooth v4.0 + LE
HW Version	DVT
SW Version	V0.150
EUT Stage	Production Unit

**Remark:** The above EUT's information was declared by manufacturer. Please refer to the specifications or user's manual for more detailed description.

### 1.4 Product Specification of Equipment Under Test

Product Specification subjective to this standard	
<b>Tx/Rx Channel Frequency Range</b>	802.11b/g/n : 2412 MHz ~ 2462 MHz 802.11a/n: 5745~5825MHz.
<b>Maximum (Peak) Output Power to Antenna</b>	<b>&lt;2412 MHz ~ 2462 MHz&gt;</b> 802.11b : 23.15 dBm (0.2065 W) 802.11g : 23.36 dBm (0.2168 W) 802.11n HT20 : 22.04 dBm (0.1600 W) 802.11n HT40 : 22.27 dBm (0.1687 W) <b>&lt;5745 MHz ~ 5825 MHz&gt;</b> 802.11a : 25.53 dBm (0.3573 W) 802.11n HT20 : 24.52 dBm (0.2831 W) 802.11n HT40 : 24.81 dBm (0.3027 W) 802.11n VHT20 : 24.62MHz (0.2897 W) 802.11n VHT40 : 24.66MHz (0.2924 W) 802.11n VHT80 : 23.65MHz (0.2317 W)
<b>99% Occupied Bandwidth</b>	<b>&lt;2412 MHz ~ 2462 MHz&gt;</b> 802.11b : 11.90MHz 802.11g : 18.30MHz 802.11n HT20 : 19.20MHz 802.11n HT40 : 36.70MHz <b>&lt;5745 MHz ~ 5825 MHz&gt;</b> 802.11a : 18.35MHz 802.11n HT20 : 19.00MHz 802.11n HT40 : 36.60MHz 802.11n VHT20 : 19.05MHz 802.11n VHT40 : 36.60MHz 802.11n VHT80 : 75.84MHz
<b>Antenna Type</b>	802.11b/g/n : PIFA Antenna type with gain 4.83 dBi 802.11a/n/ac : PIFA Antenna type with gain 5.57 dBi
<b>Type of Modulation</b>	802.11b : DSSS (DBPSK / DQPSK / CCK) 802.11a/g/n : OFDM (BPSK / QPSK / 16QAM / 64QAM)

### 1.5 Modification of EUT

No modifications are made to the EUT during all test items.



### 1.6 Testing Site

<b>Test Site</b>	SPORTON INTERNATIONAL INC.			
<b>Test Site Location</b>	No. 52, Hwa Ya 1 <sup>st</sup> Rd., Hwa Ya Technology Park, Kwei-Shan Hsiang, Tao Yuan Hsien, Taiwan, R.O.C. TEL: +886-3-3273456 / FAX: +886-3-3284978			
<b>Test Site No.</b>	<b>Sporton Site No.</b>			<b>FCC/IC Registration No.</b>
	TH02-HY	CO05-HY	03CH08-HY	636805/4086B-2

**Note:** The test site complies with ANSI C63.4 2003 requirement.

### 1.7 Applied Standards

According to the specifications of the manufacturer, the EUT must comply with the requirements of the following standards:

- ♦ FCC Part 15 Subpart C §15.247
- ♦ FCC KDB Publication No. 558074 D01 DTS Meas. Guidance v03r01
- ♦ ANSI C63.4-2003

**Remark:**

1. All test items were verified and recorded according to the standards and without any deviation during the test.
2. This EUT has also been tested and complied with the requirements of FCC Part 15, Subpart B, recorded in a separate test report.

## 2 Test Configuration of Equipment Under Test

The EUT has been associated with peripherals and configuration operated in a manner tended to maximize its emission characteristics in a typical application. Frequency range investigated: conducted emission (150 kHz to 30 MHz) and radiated emission (9 kHz to the 10th harmonic of the highest fundamental frequency or to 40 GHz, whichever is lower). For radiated measurement, pre-scanned in three orthogonal panels, X, Y, Z. The worst cases (X plane for 2.4GHz and Y plane for 5GHz) were recorded in this report.

The final configuration from all the combinations and the worst-case data rates were investigated by measuring the maximum power across all the data rates and modulation modes under section 2.2.

Based on the worst configuration found above, the RF power setting is set individually to meet FCC compliance limit for the final conducted and radiated tests shown in section 2.3.

### 2.1 Carrier Frequency Channel

Frequency Band	Channel	Freq. (MHz)	Channel	Freq. (MHz)
2400-2483.5 MHz	1	2412	7	2442
	2	2417	8	2447
	3	2422	9	2452
	4	2427	10	2457
	5	2432	11	2462
	6	2437	-	-

Frequency Band	Channel	Freq. (MHz)	Channel	Freq. (MHz)
5725-5850 MHz Band 4	149	5745	159	5795
	151	5755	161	5805
	153	5765	165	5825
	157	5785	-	-



## 2.2 Pre-Scanned RF Power

Preliminary tests were performed in different data rate and data rate associated with the highest power were chosen for full test shown in the following tables.

2.4GHz 802.11b mode				
Data Rate (MHz)	1M bps	2M bps	5.5M bps	11M bps
Peak Power (dBm)	23.15	23.09	23.07	23.14

2.4GHz 802.11g mode								
Data Rate (MHz)	6M bps	9M bps	12M bps	18M bps	24M bps	36M bps	48M bps	54M bps
Peak Power (dBm)	23.36	23.26	23.28	23.32	23.12	23.15	23.35	23.32

2.4GHz 802.11n HT20 mode								
Data Rate (MHz)	MCS0	MCS1	MCS2	MCS3	MCS4	MCS5	MCS6	MCS7
Peak Power (dBm)	22.04	22.00	22.02	21.93	22.01	21.97	21.85	21.96

2.4GHz 802.11n HT40 mode								
Data Rate (MHz)	MCS0	MCS1	MCS2	MCS3	MCS4	MCS5	MCS6	MCS7
Peak Power (dBm)	22.27	21.95	22.21	22.02	22.12	21.88	21.88	22.19

5GHz 802.11a mode								
Data Rate (MHz)	6M bps	9M bps	12M bps	18M bps	24M bps	36M bps	48M bps	54M bps
Peak Power (dBm)	25.53	25.42	25.49	25.52	25.32	25.35	25.50	25.22

5GHz 802.11n HT20 mode								
Data Rate (MHz)	MCS0	MCS1	MCS2	MCS3	MCS4	MCS5	MCS6	MCS7
Peak Power (dBm)	24.52	24.42	24.35	24.31	24.03	24.43	24.42	24.41

5GHz 802.11n HT40 mode								
Data Rate (MHz)	MCS0	MCS1	MCS2	MCS3	MCS4	MCS5	MCS6	MCS7
Peak Power (dBm)	24.81	24.71	24.49	24.42	24.23	24.11	24.19	24.43



5GHz 802.11n VHT20 mode									
Data Rate (MHz)	MCS0	MCS1	MCS2	MCS3	MCS4	MCS5	MCS6	MCS7	MCS8
Peak Power (dBm)	24.62	24.60	24.49	24.32	24.17	24.53	24.60	24.41	24.28

5GHz 802.11n VHT40 mode										
Data Rate (MHz)	MCS0	MCS1	MCS2	MCS3	MCS4	MCS5	MCS6	MCS7	MCS8	MCS9
Peak Power (dBm)	24.66	24.47	24.34	24.49	24.43	24.65	24.51	24.52	24.27	24.31

5GHz 802.11n VHT80 mode										
Data Rate (MHz)	MCS0	MCS1	MCS2	MCS3	MCS4	MCS5	MCS6	MCS7	MCS8	MCS9
Peak Power (dBm)	23.65	23.57	23.33	23.62	23.55	23.50	23.55	23.48	23.51	23.43



### 2.3 Test Mode

Final results of test modes, data rates and test channels are shown as following table.

<2.4GHz>

Test Cases				
	Test Items	Mode	Data Rate	Test Channel
Conducted TCs	6dB and 99% BW Power Spectral Density	802.11b	1 Mbps	1/6/11
		802.11g	6 Mbps	1/6/11
		802.11n HT20	MCS0	1/6/11
		802.11n HT40	MCS0	3/6/9
	Output Power	802.11b	1 Mbps	1/6/11
		802.11g	6 Mbps	1/6/11
		802.11n HT20	MCS0	1/6/11
		802.11n HT40	MCS0	3/6/9
	Conducted Band Edge	802.11b	1 Mbps	1/11
		802.11g	6 Mbps	1/11
		802.11n HT20	MCS0	1/11
		802.11n HT40	MCS0	3/9
	Conducted Spurious Emission	802.11b	1 Mbps	1/6/11
		802.11g	6 Mbps	1/6/11
		802.11n HT20	MCS0	1/6/11
		802.11n HT40	MCS0	3/6/9
Radiated TCs	Radiated Band Edge	802.11b	1 Mbps	1/11
		802.11g	6 Mbps	1/11
		802.11n HT20	MCS0	1/11
		802.11n HT40	MCS0	3/9
	Radiated Spurious Emission	802.11b	1 Mbps	1/6/11
		802.11g	6 Mbps	1/6/11
		802.11n HT20	MCS0	1/6/11
		802.11n HT40	MCS0	3/6/9



<5GHz>

Test Cases				
	Test Items	Mode	Data Rate	Test Channel
	Conducted TCs	6dB and 99% BW Power Spectral Density	802.11a	6 Mbps
802.11n HT20			MCS0	149/157/165
802.11n HT40			MCS0	151/159
802.11n VHT20			MCS0	149/157/165
802.11n VHT40			MCS0	151/159
802.11n VHT80			MCS0	155
Output Power		802.11a	6 Mbps	149/157/165
		802.11n HT20	MCS0	149/157/165
		802.11n HT40	MCS0	151/159
		802.11n VHT20	MCS0	149/157/165
		802.11n VHT40	MCS0	151/159
		802.11n VHT80	MCS0	155
Conducted Band Edge		802.11a	6 Mbps	149/165
		802.11n HT20	MCS0	149/165
		802.11n HT40	MCS0	151/159
		802.11n VHT20	MCS0	149/157/165
		802.11n VHT40	MCS0	151/159
		802.11n VHT80	MCS0	155
Conducted Spurious Emission		802.11a	6 Mbps	149/157/165
		802.11n HT20	MCS0	149/157/165
		802.11n HT40	MCS0	151/159
		802.11n VHT20	MCS0	149/157/165
		802.11n VHT40	MCS0	151/159
		802.11n VHT80	MCS0	155



<b>Radiated TCs</b>	<b>Radiated Spurious Emission</b>	<b>802.11a</b>	<b>6 Mbps</b>	<b>149/157/165</b>
		<b>802.11n HT20</b>	<b>MCS0</b>	<b>149/157/165</b>
		<b>802.11n HT40</b>	<b>MCS0</b>	<b>151/159</b>
		<b>802.11n VHT20</b>	<b>MCS0</b>	<b>149/157/165</b>
		<b>802.11n VHT40</b>	<b>MCS0</b>	<b>151/159</b>
		<b>802.11n VHT80</b>	<b>MCS0</b>	<b>155</b>

<b>Test Cases</b>	
<b>AC Conducted Emission</b>	Mode 1 : Bluetooth Link + WLAN (2.4GHz) Link + HDMI + Speaker + RJ-45 (Load) + Mouse + SD Card + MPEG4 + Adapter Mode 2 : Bluetooth Link + WLAN (5GHz) Link + HDMI + Speaker + RJ-45 (Load) + Mouse + SD Card + MPEG4 + Adapter
<b>Remark:</b> The worst case of conducted emission is mode 1; only the test data of it was reported.	

## 2.4 Connection Diagram of Test System

<WLAN Tx Mode>

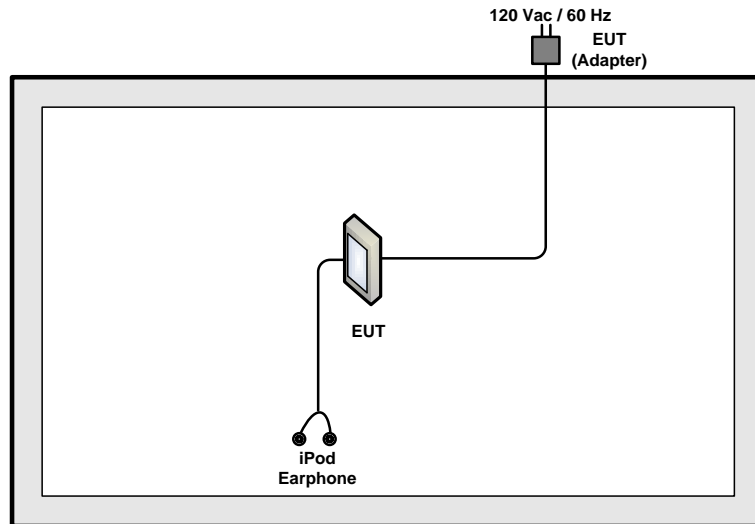

<AC Conducted Emission Mode>

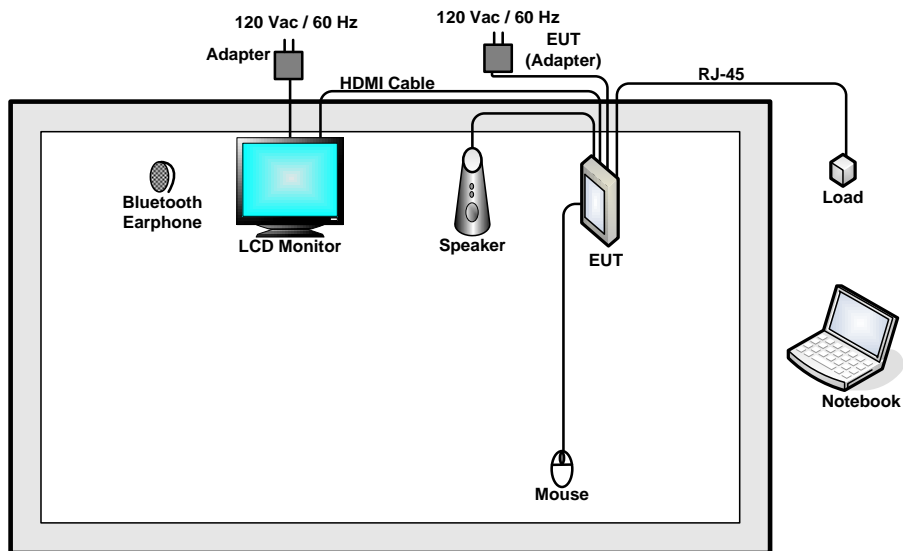

## 2.5 Support Unit used in test configuration and system

Item	Equipment	Trade Name	Model Name	FCC ID	Data Cable	Power Cord
1.	Notebook	DELL	Latitude E6320	FCC DoC	N/A	AC I/P: Unshielded, 1.2 m DC O/P: Shielded, 1.8 m
2.	LCD Monitor	DELL	ST2220Lb	FCC DoC	Shielded, 1.6m	Unshielded,1.8m
3.	Bluetooth Earphone	Sony Ericsson	MW600	PY7DDA-2029	N/A	N/A
4.	(USB) Mouse	Lenovo	M4806	FCC DoC	N/A	Unshielded, 1.8 m
5.	Speaker	N/A	N/A	N/A	N/A	Unshielded, 1.4 m
6.	SD Card	SanDisk	MicroSD HC	FCC DoC	N/A	N/A

## 2.6 EUT Operation Test Setup

For WLAN function, programmed RF utility, “WLAN test” installed in the EUT make the EUT provides functions like channel selection and power level for continuous transmitting and receiving signals.

## 2.7 Measurement Results Explanation Example

For all conducted test items:

The offset level is set in the spectrum analyzer to compensate the RF cable loss and attenuator factor between EUT conducted output port and spectrum analyzer. With the offset compensation, the spectrum analyzer reading level is exactly the EUT RF output level.

Example :

The spectrum analyzer offset is derived from RF cable loss and attenuator factor.

*Offset = RF cable loss + attenuator factor.*

Following shows an offset computation example with cable loss 4.2 dB and 10dB attenuator.

$$\begin{aligned} \text{Offset(dB)} &= \text{RF cable loss(dB)} + \text{attenuator factor(dB)}. \\ &= 4.2 + 10 = 14.2 \text{ (dB)} \end{aligned}$$

### 3 Test Result

#### 3.1 6dB and 99% Bandwidth Measurement

##### 3.1.1 Limit of 6dB and 99% Bandwidth

The minimum 6 dB bandwidth shall be at least 500 kHz.

##### 3.1.2 Measuring Instruments

The measuring equipment is listed in the section 4 of this test report.

##### 3.1.3 Test Procedures

1. The testing follows FCC KDB Publication No. 558074 DTS D01 Meas. Guidance v03r01.
2. The RF output of EUT was connected to the spectrum analyzer by RF cable and attenuator. The path loss was compensated to the results for each measurement.
3. Set to the maximum power setting and enable the EUT transmit continuously.
4. Make the measurement with the spectrum analyzer's resolution bandwidth (RBW) = 100 kHz. Set the Video bandwidth (VBW) = 300 kHz. In order to make an accurate measurement. The 6 dB bandwidth must be greater than 500 kHz.
5. For 99% Bandwidth Measurement, the spectrum analyzer's resolution bandwidth (RBW) = 1MHz and set the Video bandwidth (VBW) = 3MHz.
6. Measure and record the results in the test report.

##### 3.1.4 Test Setup

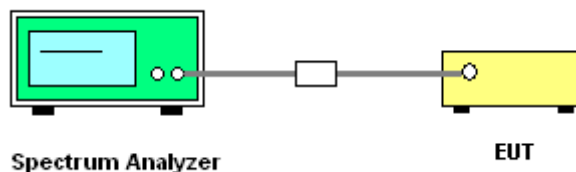





3.1.5 Test Result of 6dB and 99% Occupied Bandwidth

Test Band :	2.4GHz + 5GHz band 4	Temperature :	21~25°C
Test Engineer :	Alex Lee	Relative Humidity :	51~54%

Mod.	Data Rate	N <sub>TX</sub>	Channel	Freq. (MHz)	99% Bandwidth (MHz)	6dB Bandwidth (MHz)	6dB Bandwidth Min. Limit (MHz)	Pass/Fail
11b	1Mbps	1	1	2412	11.90	8.56	0.5	Pass
11b	1Mbps	1	6	2437	11.80	9.04	0.5	Pass
11b	1Mbps	1	11	2462	11.85	9.04	0.5	Pass
11g	6Mbps	1	1	2412	18.25	16.32	0.5	Pass
11g	6Mbps	1	6	2437	18.30	16.32	0.5	Pass
11g	6Mbps	1	11	2462	18.20	16.32	0.5	Pass
HT20	MCS0	1	1	2412	19.05	17.60	0.5	Pass
HT20	MCS0	1	6	2437	19.20	17.58	0.5	Pass
HT20	MCS0	1	11	2462	19.05	17.60	0.5	Pass
HT40	MCS0	1	3	2422	36.70	36.32	0.5	Pass
HT40	MCS0	1	6	2437	36.70	36.28	0.5	Pass
HT40	MCS0	1	9	2452	36.60	36.32	0.5	Pass



Mod.	Data Rate	N <sub>TX</sub>	Channel	Freq. (MHz)	99% Bandwidth (MHz)	6dB Bandwidth (MHz)	6dB Bandwidth Min. Limit (MHz)	Pass/Fail
11a	6Mbps	1	149	5745	18.35	16.36	0.5	Pass
11a	6Mbps	1	157	5785	18.35	16.36	0.5	Pass
11a	6Mbps	1	165	5825	18.35	16.32	0.5	Pass
HT20	MCS0	1	149	5745	18.95	17.58	0.5	Pass
HT20	MCS0	1	157	5785	18.80	17.60	0.5	Pass
HT20	MCS0	1	165	5825	19.00	17.56	0.5	Pass
HT40	MCS0	1	151	5755	36.60	36.32	0.5	Pass
HT40	MCS0	1	159	5795	36.60	36.32	0.5	Pass
VHT20	MCS0	1	149	5745	18.80	17.60	0.5	Pass
VHT20	MCS0	1	157	5785	19.05	17.56	0.5	Pass
VHT20	MCS0	1	165	5825	18.80	17.56	0.5	Pass
VHT40	MCS0	1	151	5755	36.60	36.32	0.5	Pass
VHT40	MCS0	1	159	5795	36.60	36.32	0.5	Pass
VHT80	MCS0	1	155	5775	75.84	75.98	0.5	Pass

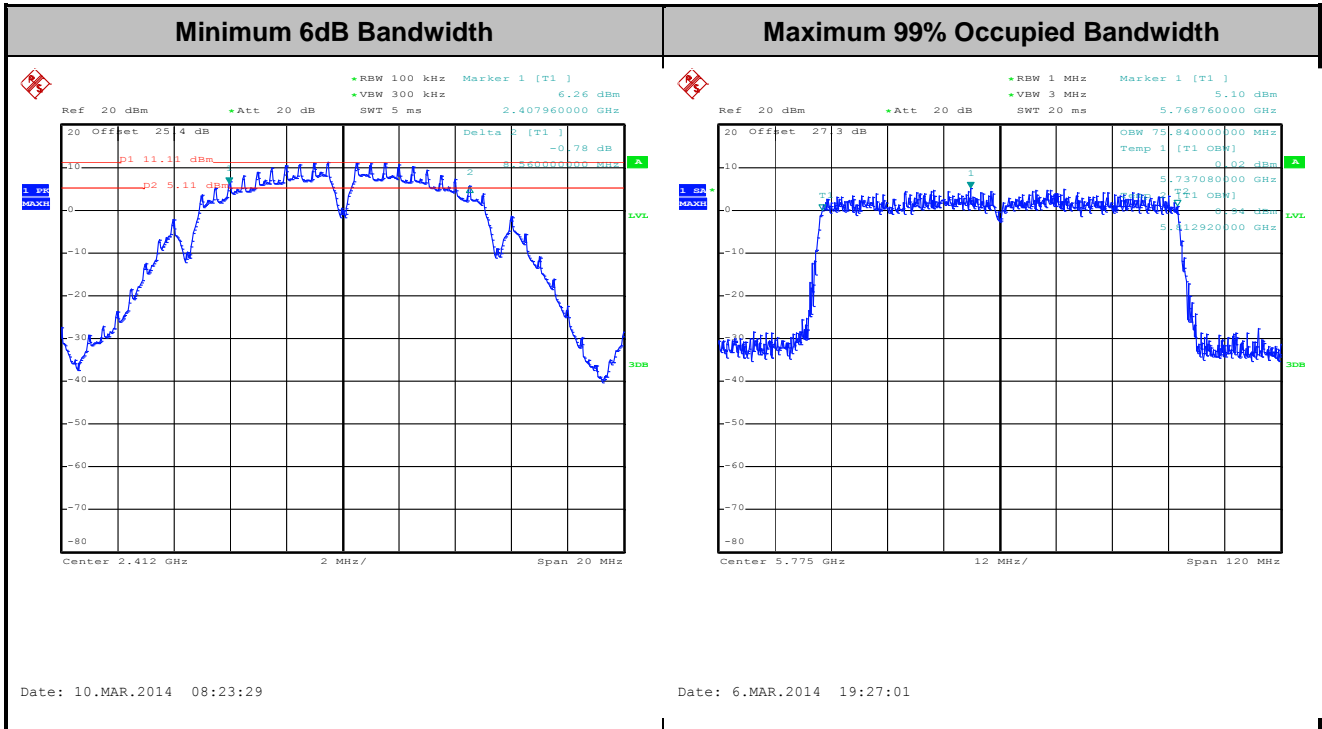

Note : The occupied channel bandwidth is maintained within the band of operation for all of the modulations.

## 3.2 Output Power Measurement

### 3.2.1 Limit of Output Power

For systems using digital modulation in the 2400-2483.5MHz and 5725-5850MHz, the limit for peak output power is 30dBm. If transmitting Antenna of directional gain greater than 6dBi are used the peak output power from the intentional radiator shall be reduced below the above stated value by the amount in dB that the directional gain of the Antenna exceeds 6 dBi. In case of point-to-point operation, the limit has to be reduced by 1dB for every 3dB that the directional gain of the Antenna exceeds 6dBi.

### 3.2.2 Measuring Instruments

The measuring equipment is listed in the section 4 of this test report.

### 3.2.3 Test Procedures

1. The testing follows the Measurement Procedure of FCC KDB No. 558074 DTS D01 Meas. Guidance v03r01.
2. The RF output of EUT was connected to the power meter by RF cable and attenuator. The path loss was compensated to the results for each measurement.
3. Set to the maximum power setting and enable the EUT transmit continuously.
4. Measure the conducted output power and record the results in the test report.

### 3.2.4 Test Setup

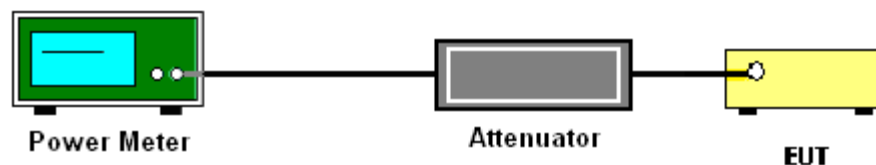



3.2.5 Test Result of Peak Output Power

Test Mode :	2.4GHz + 5GHz band 4	Temperature :	21~25°C
Test Engineer :	Alex Lee	Relative Humidity :	51~54%

Mod.	Data Rate	N <sub>TX</sub>	Channel	Freq. (MHz)	RF Output Power (dBm)	Power Limit (dBm)	DG (dBi)	Pass/Fail
11b	1Mbps	1	1	2412	23.15	30	4.83	Pass
11b	1Mbps	1	6	2437	22.79	30	4.83	Pass
11b	1Mbps	1	11	2462	22.38	30	4.83	Pass
11g	6Mbps	1	1	2412	23.23	30	4.83	Pass
11g	6Mbps	1	6	2437	23.36	30	4.83	Pass
11g	6Mbps	1	11	2462	23.16	30	4.83	Pass
HT20	MCS0	1	1	2412	22.04	30	4.83	Pass
HT20	MCS0	1	6	2437	21.93	30	4.83	Pass
HT20	MCS0	1	11	2462	21.58	30	4.83	Pass
HT40	MCS0	1	3	2422	20.60	30	4.83	Pass
HT40	MCS0	1	6	2437	22.27	30	4.83	Pass
HT40	MCS0	1	9	2452	22.13	30	4.83	Pass



Mod.	Data Rate	N <sub>TX</sub>	Channel	Freq. (MHz)	RF Output Power (dBm)	Power Limit (dBm)	DG (dBi)	Pass/Fail
11a	6Mbps	1	149	5745	25.52	30	5.45	Pass
11a	6Mbps	1	157	5785	25.53	30	5.45	Pass
11a	6Mbps	1	165	5825	25.52	30	5.45	Pass
HT20	MCS0	1	149	5745	24.43	30	5.45	Pass
HT20	MCS0	1	157	5785	24.52	30	5.45	Pass
HT20	MCS0	1	165	5825	24.40	30	5.45	Pass
HT40	MCS0	1	151	5755	24.54	30	5.45	Pass
HT40	MCS0	1	159	5795	24.81	30	5.45	Pass
VHT20	MCS0	1	149	5745	24.54	30	5.45	Pass
VHT20	MCS0	1	157	5785	24.41	30	5.45	Pass
VHT20	MCS0	1	165	5825	24.62	30	5.45	Pass
VHT40	MCS0	1	151	5755	24.66	30	5.45	Pass
VHT40	MCS0	1	159	5795	24.58	30	5.45	Pass
VHT80	MCS0	1	155	5775	23.65	30	5.45	Pass

Note: Measured power (dBm) has offset with cable loss.



3.2.6 Test Result of Average output Power (Reporting Only)

Test Mode :	2.4GHz + 5GHz band 4	Temperature :	21~25°C
Test Engineer :	Alex Lee	Relative Humidity :	51~54%

Mod.	Data Rate	N <sub>TX</sub>	Channel	Freq. (MHz)	Duty Factor (dB)	Average Output Power (dBm)	Power Limit (dBm)	DG (dBi)	Pass/Fail
11b	1Mbps	1	1	2412	0.08	20.01	30	4.83	Pass
11b	1Mbps	1	6	2437	0.08	19.56	30	4.83	Pass
11b	1Mbps	1	11	2462	0.08	19.10	30	4.83	Pass
11g	6Mbps	1	1	2412	0.52	13.93	30	4.83	Pass
11g	6Mbps	1	6	2437	0.52	14.44	30	4.83	Pass
11g	6Mbps	1	11	2462	0.52	13.87	30	4.83	Pass
HT20	MCS0	1	1	2412	0.53	11.93	30	4.83	Pass
HT20	MCS0	1	6	2437	0.53	11.53	30	4.83	Pass
HT20	MCS0	1	11	2462	0.53	10.94	30	4.83	Pass
HT40	MCS0	1	3	2422	1.01	9.70	30	4.83	Pass
HT40	MCS0	1	6	2437	1.01	11.95	30	4.83	Pass
HT40	MCS0	1	9	2452	1.01	11.65	30	4.83	Pass



Mod.	Data Rate	N <sub>TX</sub>	Channel	Freq. (MHz)	Duty Factor (dB)	Average Output Power (dBm)	Power Limit (dBm)	DG (dBi)	Pass/Fail
11a	6Mbps	1	149	5745	0.51	18.76	30	5.45	Pass
11a	6Mbps	1	157	5785	0.51	18.79	30	5.45	Pass
11a	6Mbps	1	165	5825	0.51	18.77	30	5.45	Pass
HT20	MCS0	1	149	5745	0.53	15.59	30	5.45	Pass
HT20	MCS0	1	157	5785	0.53	15.69	30	5.45	Pass
HT20	MCS0	1	165	5825	0.53	15.56	30	5.45	Pass
HT40	MCS0	1	151	5755	1.02	15.64	30	5.45	Pass
HT40	MCS0	1	159	5795	1.02	15.72	30	5.45	Pass
VHT20	MCS0	1	149	5745	0.53	15.81	30	5.45	Pass
VHT20	MCS0	1	157	5785	0.53	15.51	30	5.45	Pass
VHT20	MCS0	1	165	5825	0.53	15.93	30	5.45	Pass
VHT40	MCS0	1	151	5755	1.01	15.78	30	5.45	Pass
VHT40	MCS0	1	159	5795	1.01	15.63	30	5.45	Pass
VHT80	MCS0	1	155	5775	1.85	15.43	30	5.45	Pass

**Note:** Measured power (dBm) has offset with cable loss and duty factor.



### 3.3 Power Spectral Density Measurement

#### 3.3.1 Limit of Power Spectral Density

The peak power spectral density shall not be greater than 8dBm in any 3kHz band at any time interval of continuous transmission.

#### 3.3.2 Measuring Instruments

The measuring equipment is listed in the section 4 of this test report.

#### 3.3.3 Test Procedures

1. The testing follows Measurement Procedure 10.2 Method PKPSD of FCC KDB Publication No. 558074 D01 DTS Meas. Guidance v03r01
2. The RF output of EUT was connected to the spectrum analyzer by RF cable and attenuator. The path loss was compensated to the results for each measurement.
3. Set to the maximum power setting and enable the EUT transmit continuously.
4. Make the measurement with the spectrum analyzer's resolution bandwidth (RBW) = 3 kHz. Video bandwidth VBW = 10 kHz In order to make an accurate measurement, set the span to 1.5 times DTS Channel Bandwidth. (6dB BW)
5. Detector = peak, Sweep time = auto couple, Trace mode = max hold, Allow trace to fully stabilize. Use the peak marker function to determine the maximum power level.
6. Measure and record the results in the test report.

#### 3.3.4 Test Setup

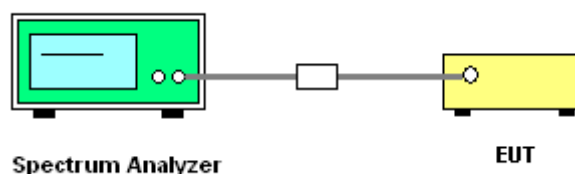



3.3.5 Test Result of Power Spectral Density

Test Mode :	2.4GHz + 5GHz band 4	Temperature :	21~25°C
Test Engineer :	Alex Lee	Relative Humidity :	51~54%

Mod.	Data Rate	N <sub>TX</sub>	Channel	Freq. (MHz)	Peak Power Density (dBm/3kHz)	Max. Limits (dBm/3kHz)	DG (dBi)	Pass/Fail
11b	1Mbps	1	1	2412	-2.56	8	4.83	Pass
11b	1Mbps	1	6	2437	-3.21	8	4.83	Pass
11b	1Mbps	1	11	2462	-4.12	8	4.83	Pass
11g	6Mbps	1	1	2412	-11.68	8	4.83	Pass
11g	6Mbps	1	6	2437	-11.20	8	4.83	Pass
11g	6Mbps	1	11	2462	-12.15	8	4.83	Pass
HT20	MCS0	1	1	2412	-14.21	8	4.83	Pass
HT20	MCS0	1	6	2437	-14.96	8	4.83	Pass
HT20	MCS0	1	11	2462	-15.28	8	4.83	Pass
HT40	MCS0	1	3	2422	-17.31	8	4.83	Pass
HT40	MCS0	1	6	2437	-16.19	8	4.83	Pass
HT40	MCS0	1	9	2452	-18.16	8	4.83	Pass



Mod.	Data Rate	N <sub>TX</sub>	Channel	Freq. (MHz)	Peak Power Density (dBm/3kHz)	Max. Limits (dBm/3kHz)	DG (dBi)	Pass/Fail
11a	6Mbps	1	149	5745	-6.18	8	5.45	Pass
11a	6Mbps	1	157	5785	-5.67	8	5.45	Pass
11a	6Mbps	1	165	5825	-6.15	8	5.45	Pass
HT20	MCS0	1	149	5745	-8.73	8	5.45	Pass
HT20	MCS0	1	157	5785	-10.92	8	5.45	Pass
HT20	MCS0	1	165	5825	-10.15	8	5.45	Pass
HT40	MCS0	1	151	5755	-11.76	8	5.45	Pass
HT40	MCS0	1	159	5795	-12.62	8	5.45	Pass
VHT20	MCS0	1	149	5745	-11.03	8	5.45	Pass
VHT20	MCS0	1	157	5785	-10.49	8	5.45	Pass
VHT20	MCS0	1	165	5825	-10.30	8	5.45	Pass
VHT40	MCS0	1	151	5755	-13.23	8	5.45	Pass
VHT40	MCS0	1	159	5795	-13.31	8	5.45	Pass
VHT80	MCS0	1	155	5775	-16.57	8	5.45	Pass

**Note:** Measured power density (dBm) has offset with cable loss.

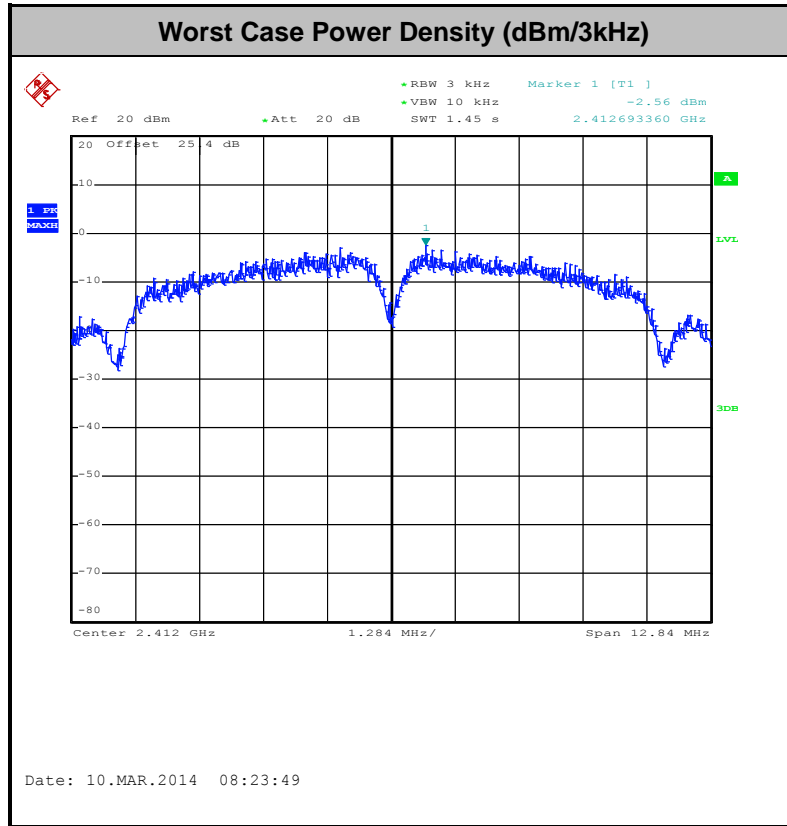

## 3.4 Conducted Band Edges and Spurious Emission Measurement

### 3.4.1 Limit of Conducted Band Edges and Spurious Emission Measurement

In any 100 kHz bandwidth outside of the authorized frequency band, the emissions which fall in the non-restricted bands shall be attenuated at least 20 dB / 30dB relative to the maximum PSD level in 100 kHz by RF conducted measurement and radiated emissions which fall in the restricted bands, as defined in Section 15.205(a), must also comply with the radiated emission limits specified in Section 15.209(a).

### 3.4.2 Measuring Instruments

The measuring equipment is listed in the section 4 of this test report.

### 3.4.3 Test Procedures

1. The testing follows FCC KDB Publication No. 558074 D01 DTS Meas. Guidance v03r01.
2. The RF output of EUT was connected to the spectrum analyzer by RF cable and attenuator. The path loss was compensated to the results for each measurement.
3. Set to the maximum power setting and enable the EUT transmit continuously.
4. Set RBW = 100 kHz, VBW=300 kHz, Peak Detector. Unwanted Emissions measured in any 100 kHz bandwidth outside of the authorized frequency band shall be attenuated by at least 20 dB relative to the maximum in-band peak PSD level in 100 kHz when maximum peak conducted output power procedure is used. If the transmitter complies with the conducted power limits based on the use of RMS averaging over a time interval, the attenuation required under this paragraph shall be 30 dB instead of 20 dB per 15.247(d).
5. Measure and record the results in the test report.
6. The RF fundamental frequency should be excluded against the limit line in the operating frequency band.

### 3.4.4 Test Setup

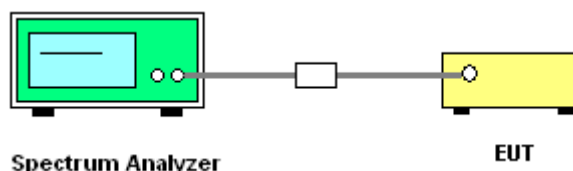



### 3.4.5 Test Result of Conducted Band Edges and Spurious Emission

Test Mode :	802.11b	Temperature :	21~25°C
Test Band :	2.4GHz Low	Relative Humidity :	51~54%
Test Channel :	01	Test Engineer :	Alex Lee

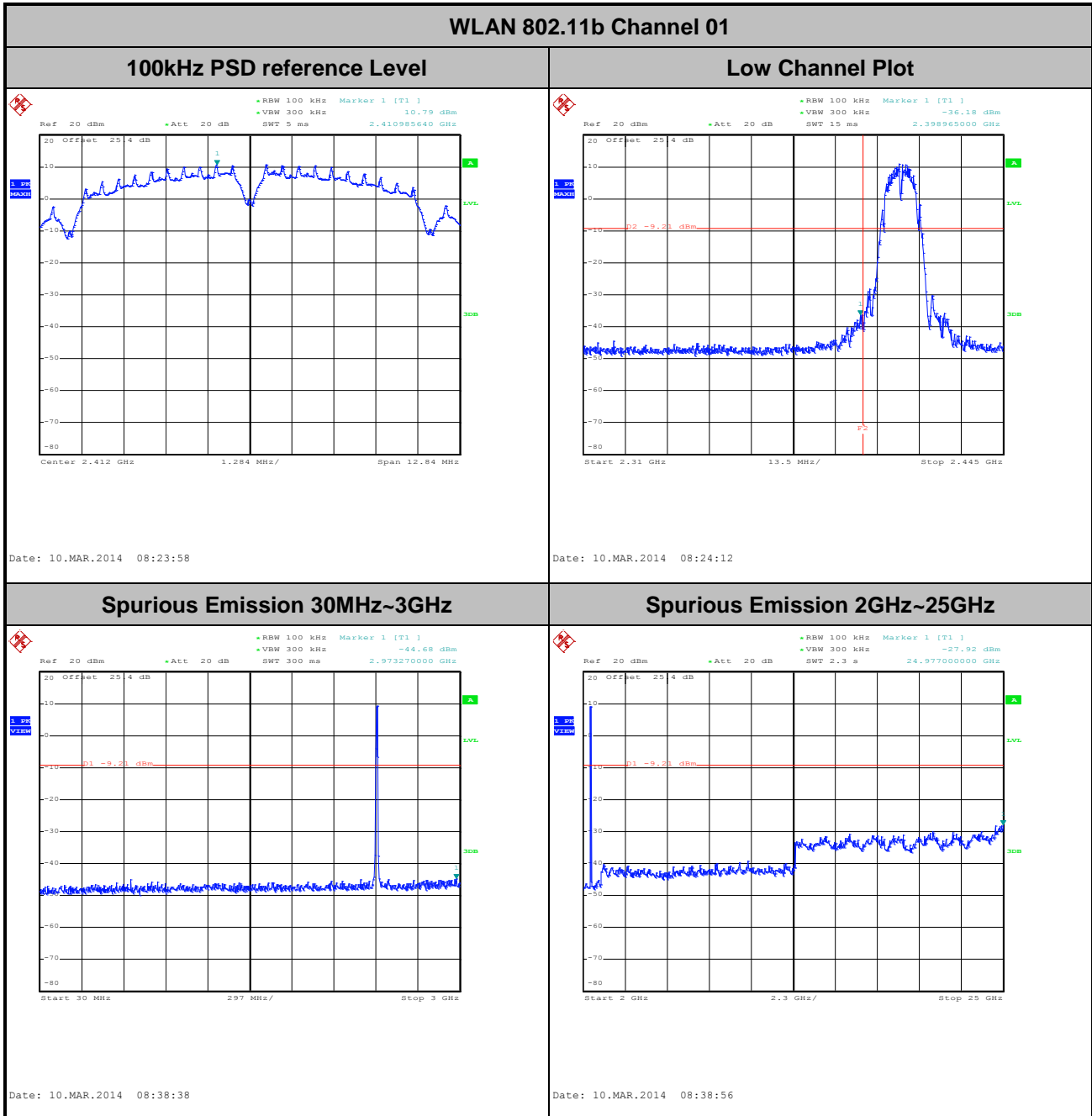



Test Mode :	802.11b	Temperature :	21~25°C
Test Band :	2.4GHz Mid	Relative Humidity :	51~54%
Test Channel :	06	Test Engineer :	Alex Lee

WLAN 802.11b Channel 06

100kHz PSD reference Level

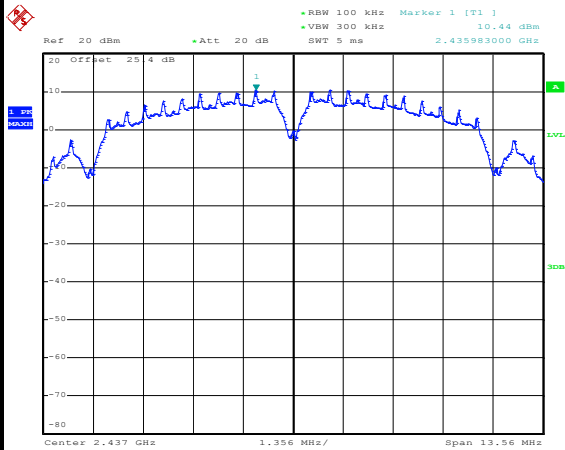

Date: 10.MAR.2014 08:28:25

Spurious Emission 30MHz~3GHz

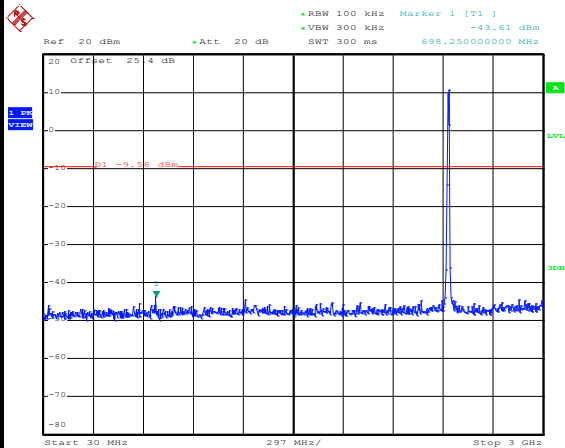

Date: 10.MAR.2014 08:28:45

Spurious Emission 2GHz~25GHz

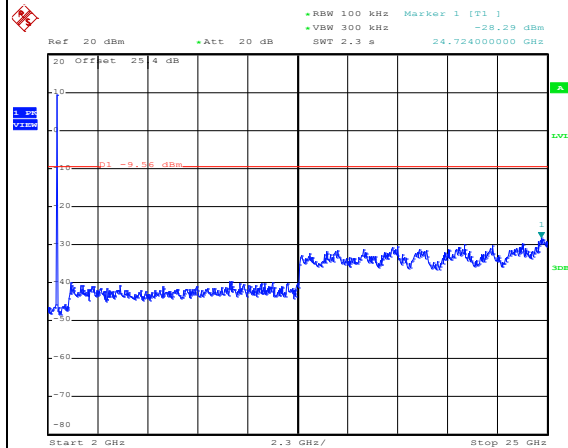

Date: 10.MAR.2014 08:29:04



Test Mode :	802.11b	Temperature :	21~25°C
Test Band :	2.4GHz High	Relative Humidity :	51~54%
Test Channel :	11	Test Engineer :	Alex Lee

WLAN 802.11b Channel 11

100kHz PSD reference Level

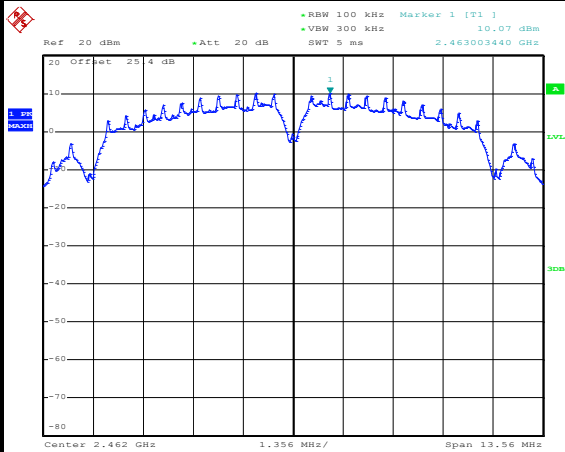

Date: 10.MAR.2014 08:35:26

High Channel Plot

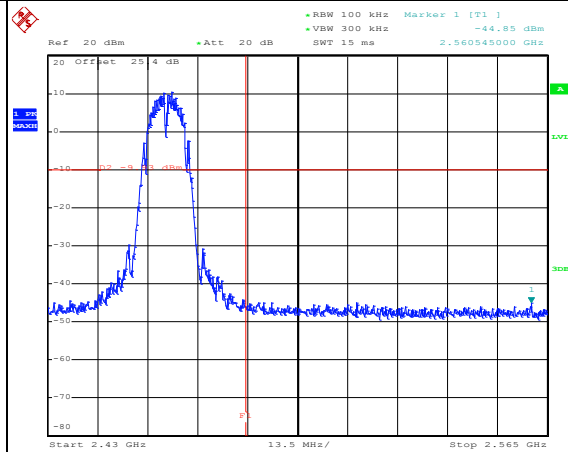

Date: 10.MAR.2014 08:35:40

Spurious Emission 30MHz~3GHz

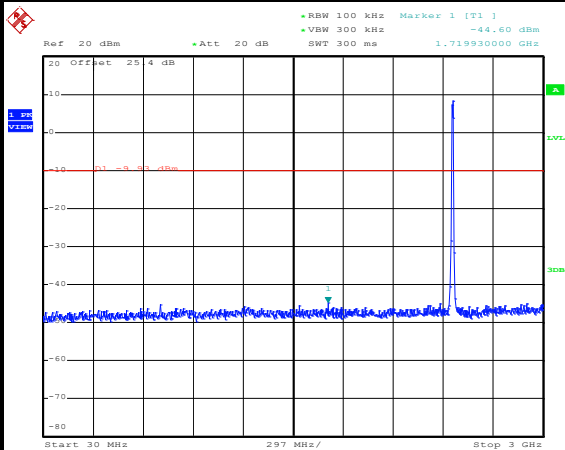

Date: 10.MAR.2014 08:35:59

Spurious Emission 2GHz~25GHz

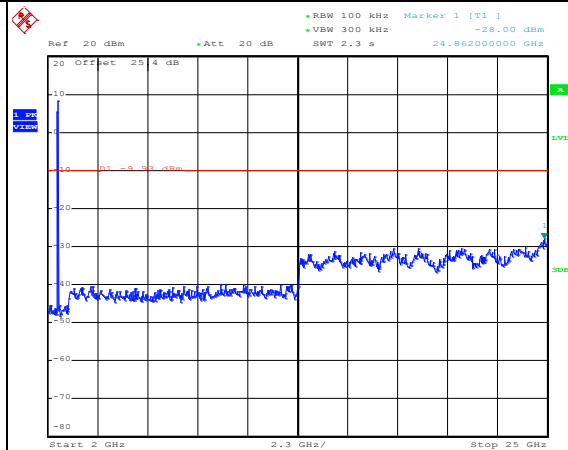

Date: 10.MAR.2014 08:36:18





Test Mode :	802.11g	Temperature :	21~25°C
Test Band :	2.4GHz Low	Relative Humidity :	51~54%
Test Channel :	01	Test Engineer :	Alex Lee

WLAN 802.11g Channel 01

100kHz PSD reference Level

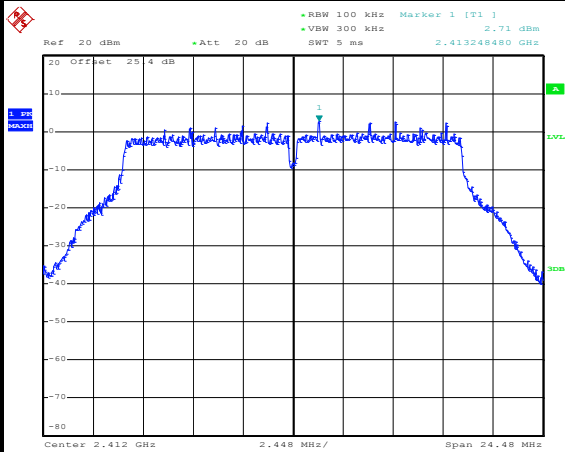

Date: 10.MAR.2014 08:57:57

Low Channel Plot

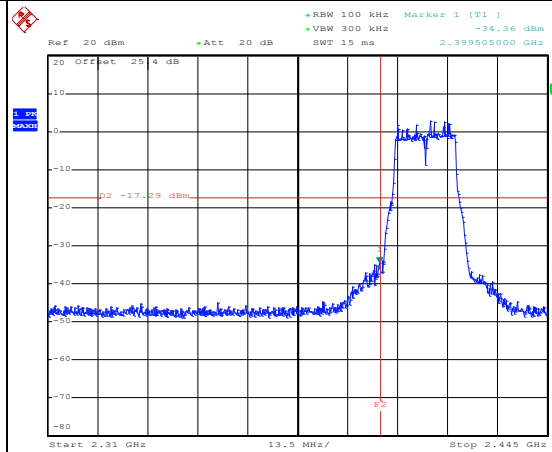

Date: 10.MAR.2014 08:58:10

Spurious Emission 30MHz~3GHz

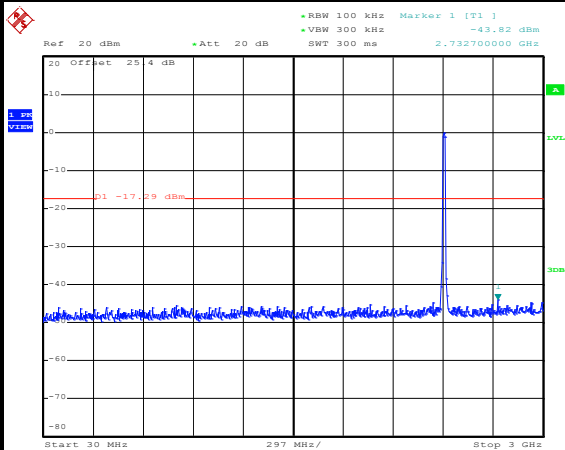

Date: 10.MAR.2014 08:58:29

Spurious Emission 2GHz~25GHz

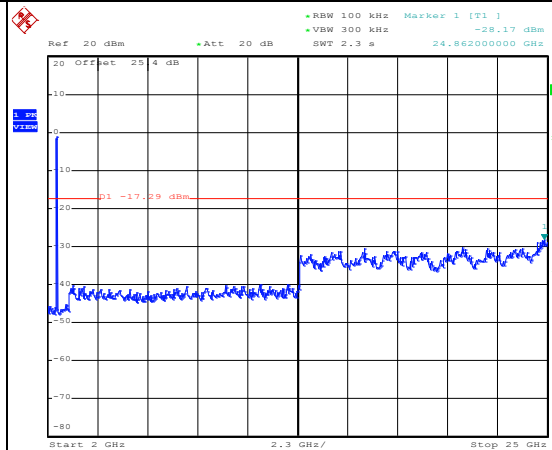

Date: 10.MAR.2014 08:58:48



Test Mode :	802.11g	Temperature :	21~25°C
Test Band :	2.4GHz Mid	Relative Humidity :	51~54%
Test Channel :	06	Test Engineer :	Alex Lee

WLAN 802.11g Channel 06

100kHz PSD reference Level

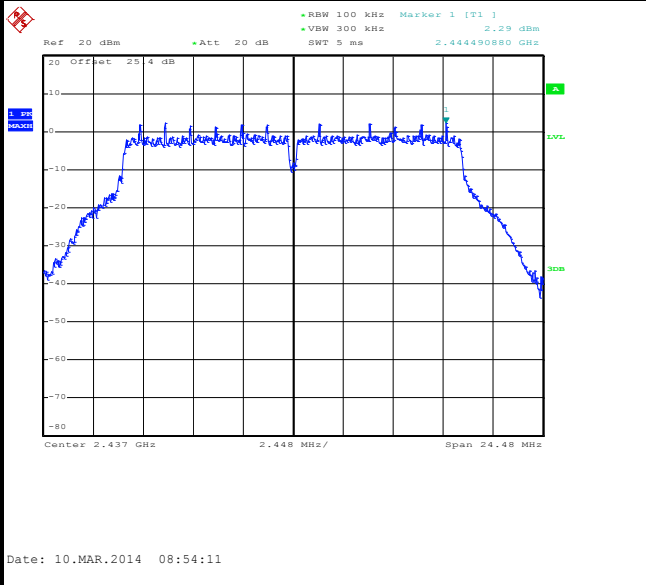

Spurious Emission 30MHz~3GHz

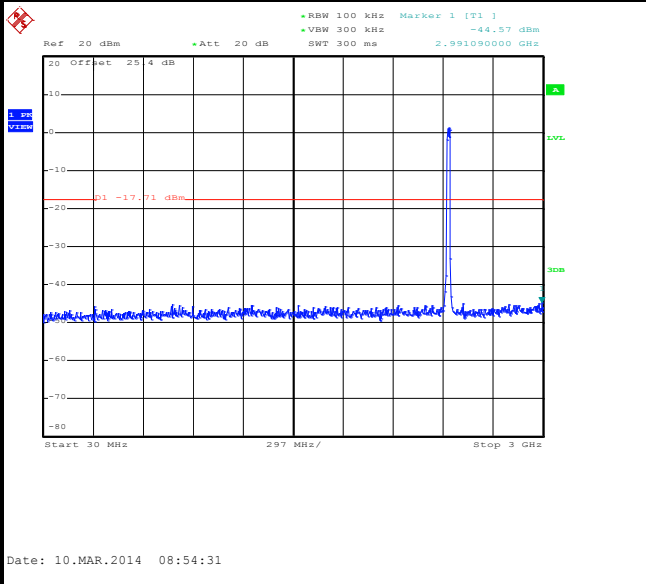

Spurious Emission 2GHz~25GHz

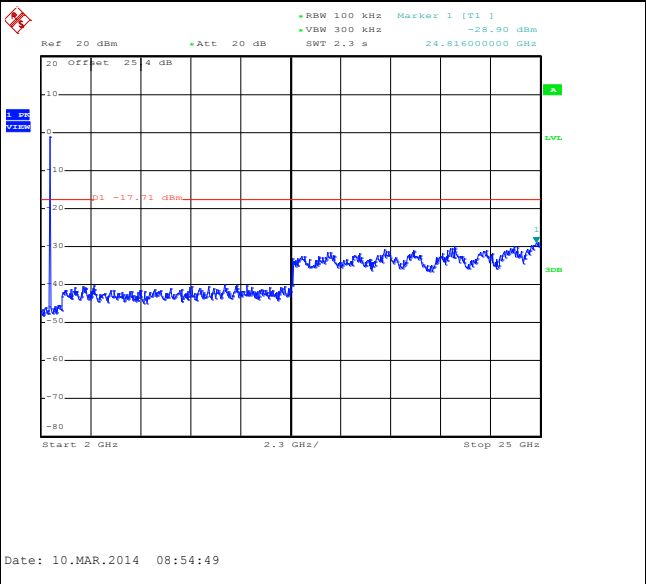



Test Mode :	802.11g	Temperature :	21~25°C
Test Band :	2.4GHz High	Relative Humidity :	51~54%
Test Channel :	11	Test Engineer :	Alex Lee

WLAN 802.11g Channel 11

100kHz PSD reference Level

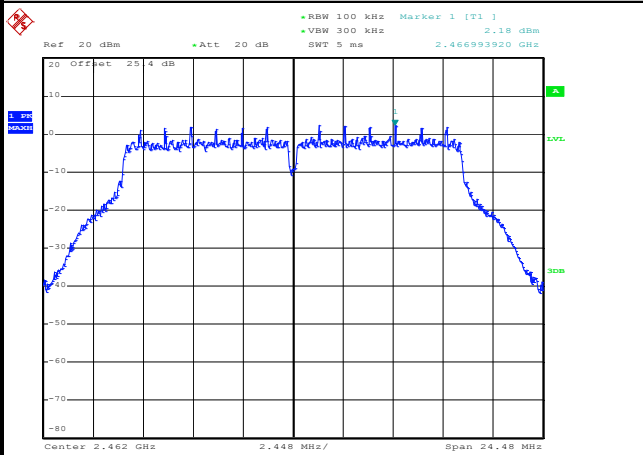

Date: 10.MAR.2014 08:50:38

High Channel Plot

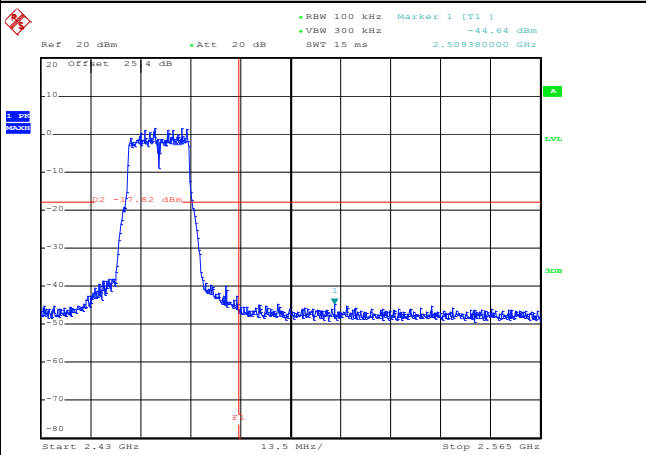

Date: 10.MAR.2014 08:50:51

Spurious Emission 30MHz~3GHz

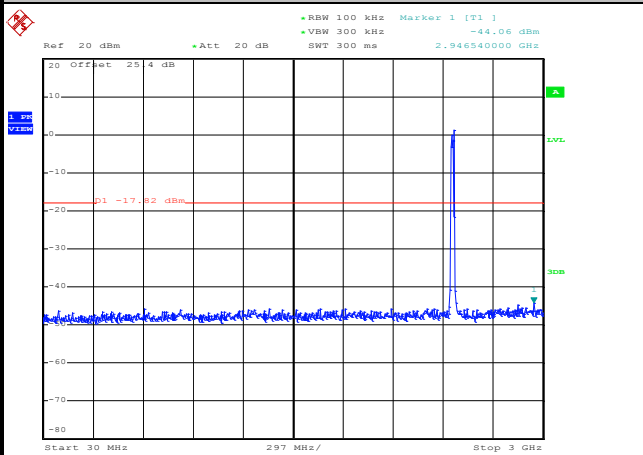

Date: 10.MAR.2014 08:51:11

Spurious Emission 2GHz~25GHz

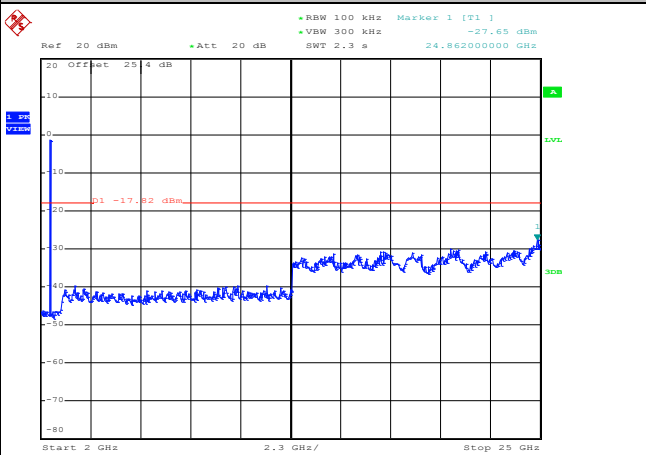

Date: 10.MAR.2014 08:51:29



Test Mode :	802.11n HT20	Temperature :	21~25°C
Test Band :	2.4GHz Low	Relative Humidity :	51~54%
Test Channel :	01	Test Engineer :	Alex Lee

WLAN 802.11n HT20 Channel 01

100kHz PSD reference Level

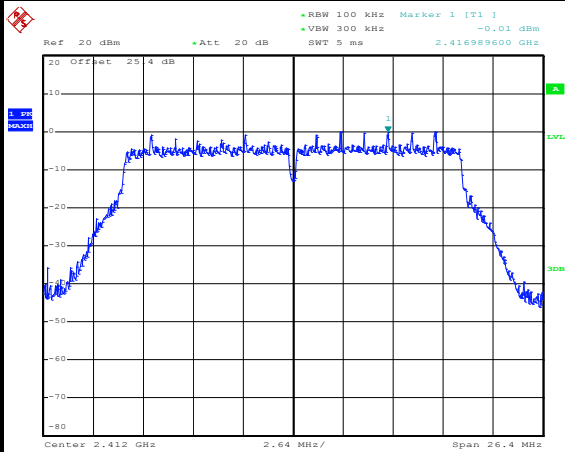

Date: 10.MAR.2014 09:04:47

Low Channel Plot

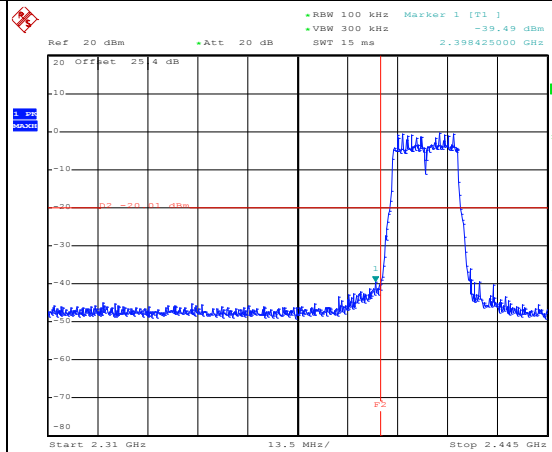

Date: 10.MAR.2014 09:05:00

Spurious Emission 30MHz~3GHz

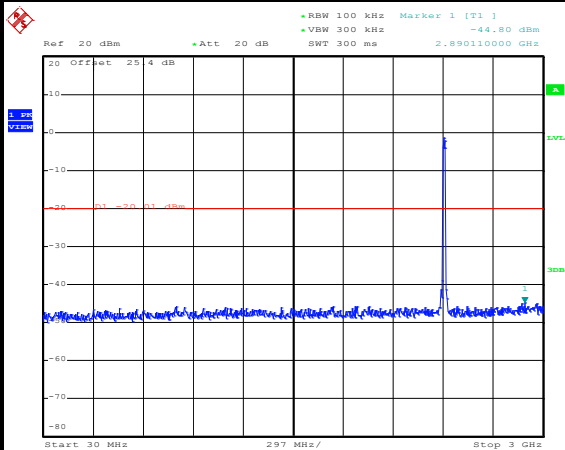

Date: 10.MAR.2014 09:05:19

Spurious Emission 2GHz~25GHz

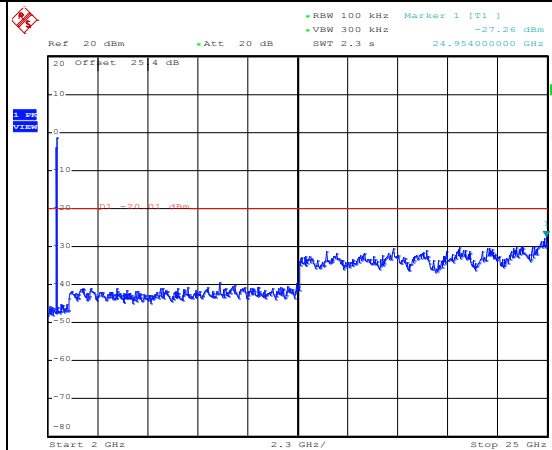

Date: 10.MAR.2014 09:05:38



Test Mode :	802.11n HT20	Temperature :	21~25°C
Test Band :	2.4GHz Mid	Relative Humidity :	51~54%
Test Channel :	06	Test Engineer :	Alex Lee

WLAN 802.11n HT20 Channel 06

100kHz PSD reference Level

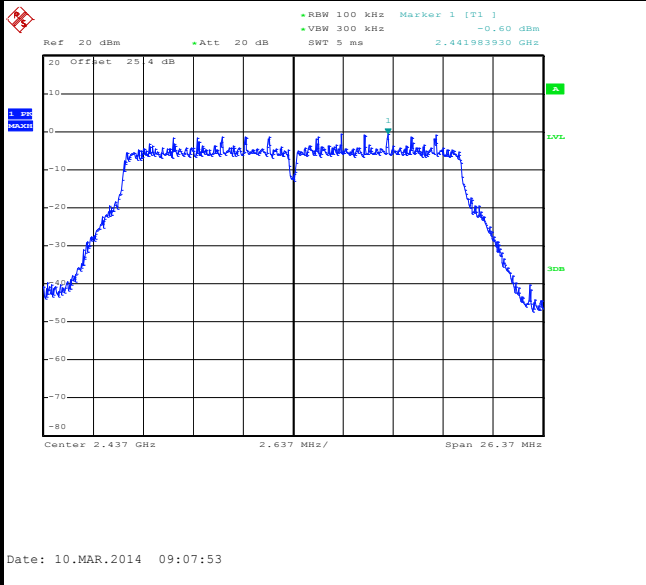

Spurious Emission 30MHz~3GHz

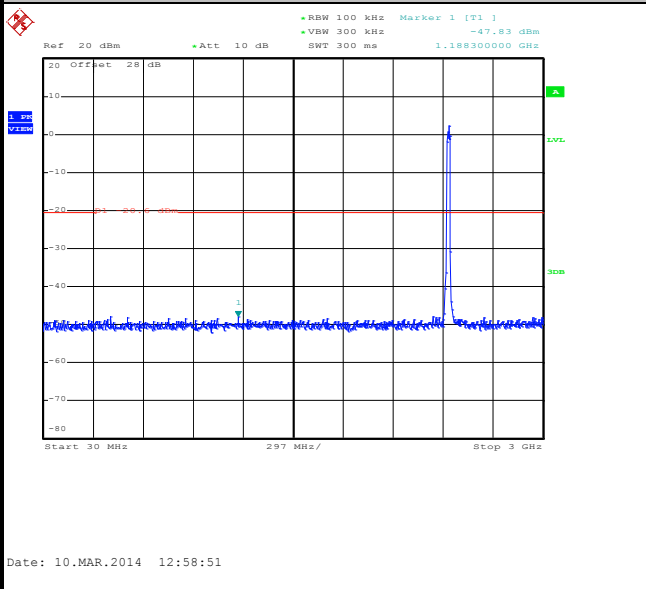

Spurious Emission 2GHz~25GHz

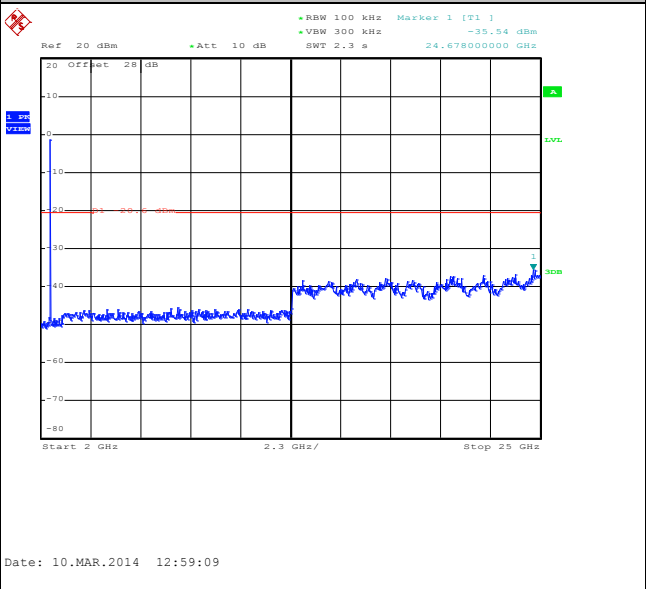



Test Mode :	802.11n HT20	Temperature :	21~25°C
Test Band :	2.4GHz High	Relative Humidity :	51~54%
Test Channel :	11	Test Engineer :	Alex Lee

WLAN 802.11n HT20 Channel 11

100kHz PSD reference Level

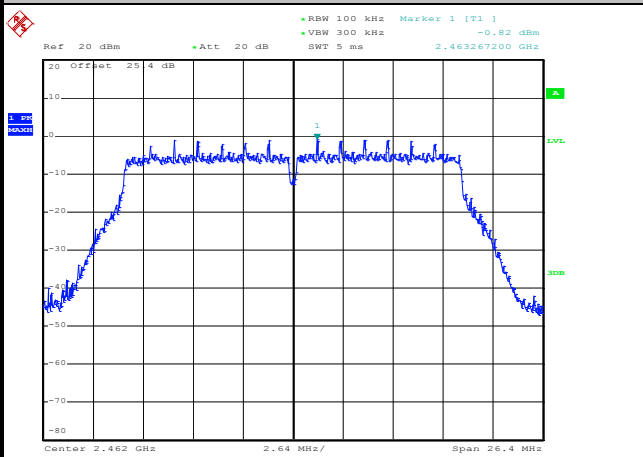

Date: 10.MAR.2014 09:11:06

High Channel Plot

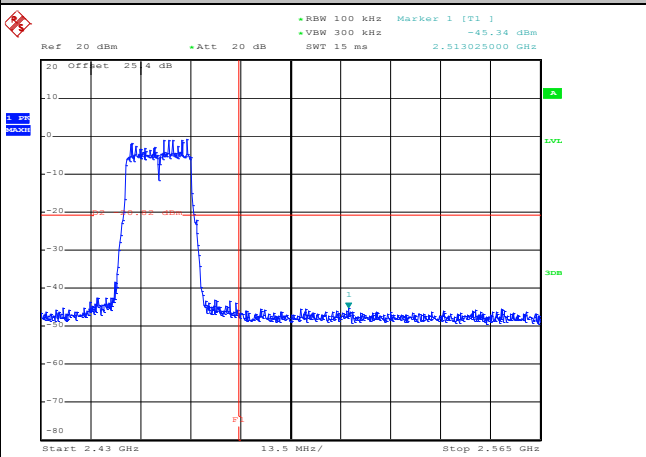

Date: 10.MAR.2014 09:11:19

Spurious Emission 30MHz~3GHz

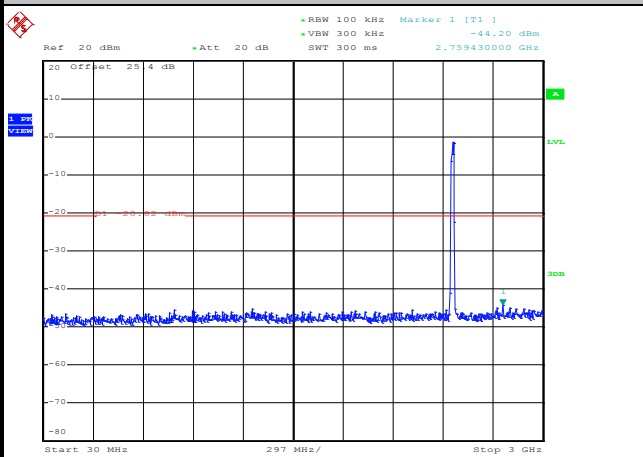

Date: 10.MAR.2014 09:11:38

Spurious Emission 2GHz~25GHz

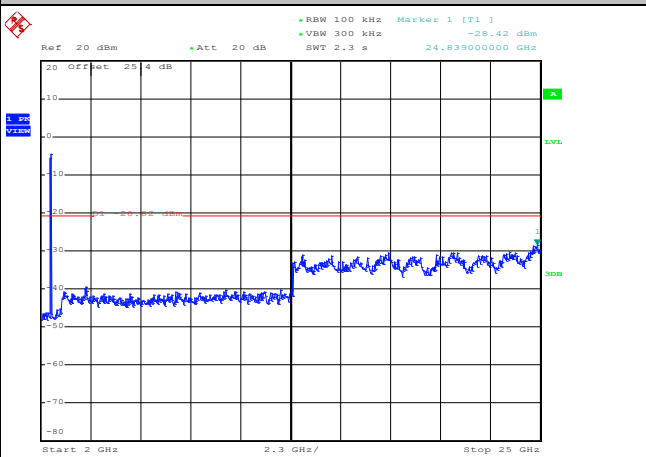

Date: 10.MAR.2014 09:11:57



Test Mode :	802.11n HT40	Temperature :	21~25°C
Test Band :	2.4GHz Low	Relative Humidity :	51~54%
Test Channel :	03	Test Engineer :	Alex Lee

WLAN 802.11n HT40 Channel 03

100kHz PSD reference Level

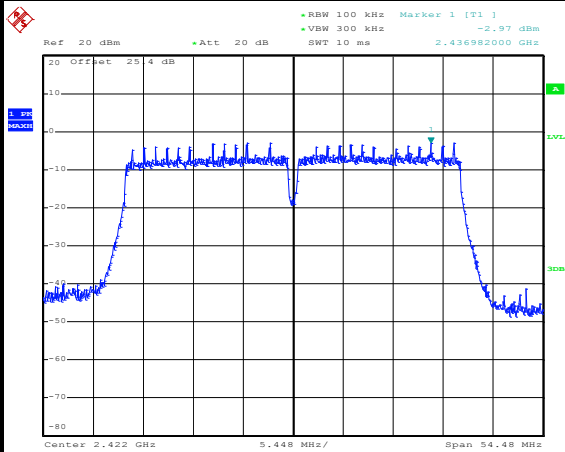

Date: 10.MAR.2014 09:16:51

Low Channel Plot

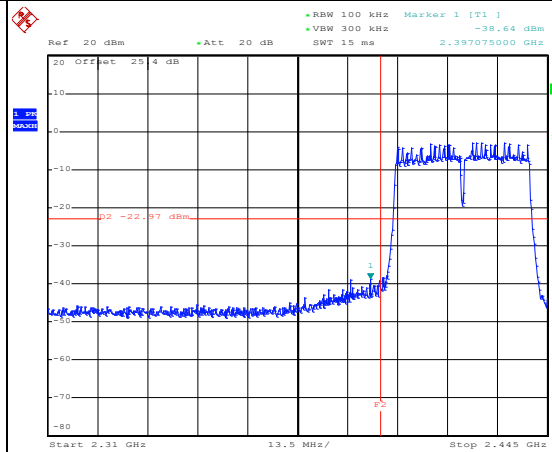

Date: 10.MAR.2014 09:17:05

Spurious Emission 30MHz~3GHz

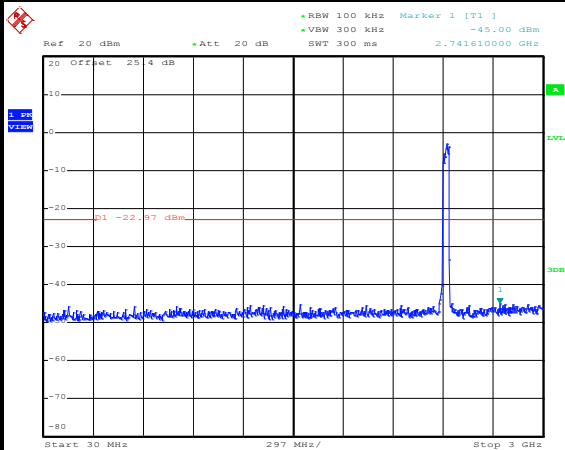

Date: 10.MAR.2014 09:19:16

Spurious Emission 2GHz~25GHz

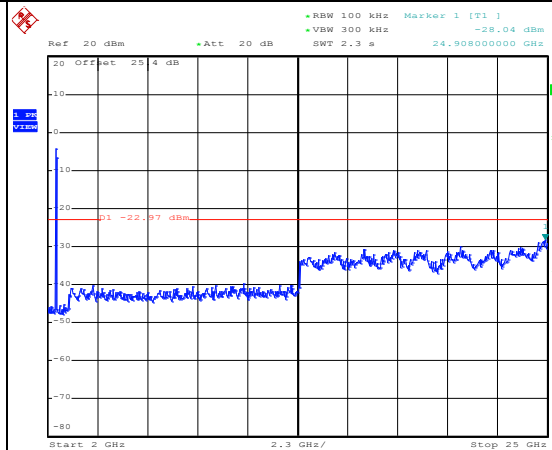

Date: 10.MAR.2014 09:19:35



Test Mode :	802.11n HT40	Temperature :	21~25°C
Test Band :	2.4GHz Mid	Relative Humidity :	51~54%
Test Channel :	06	Test Engineer :	Alex Lee

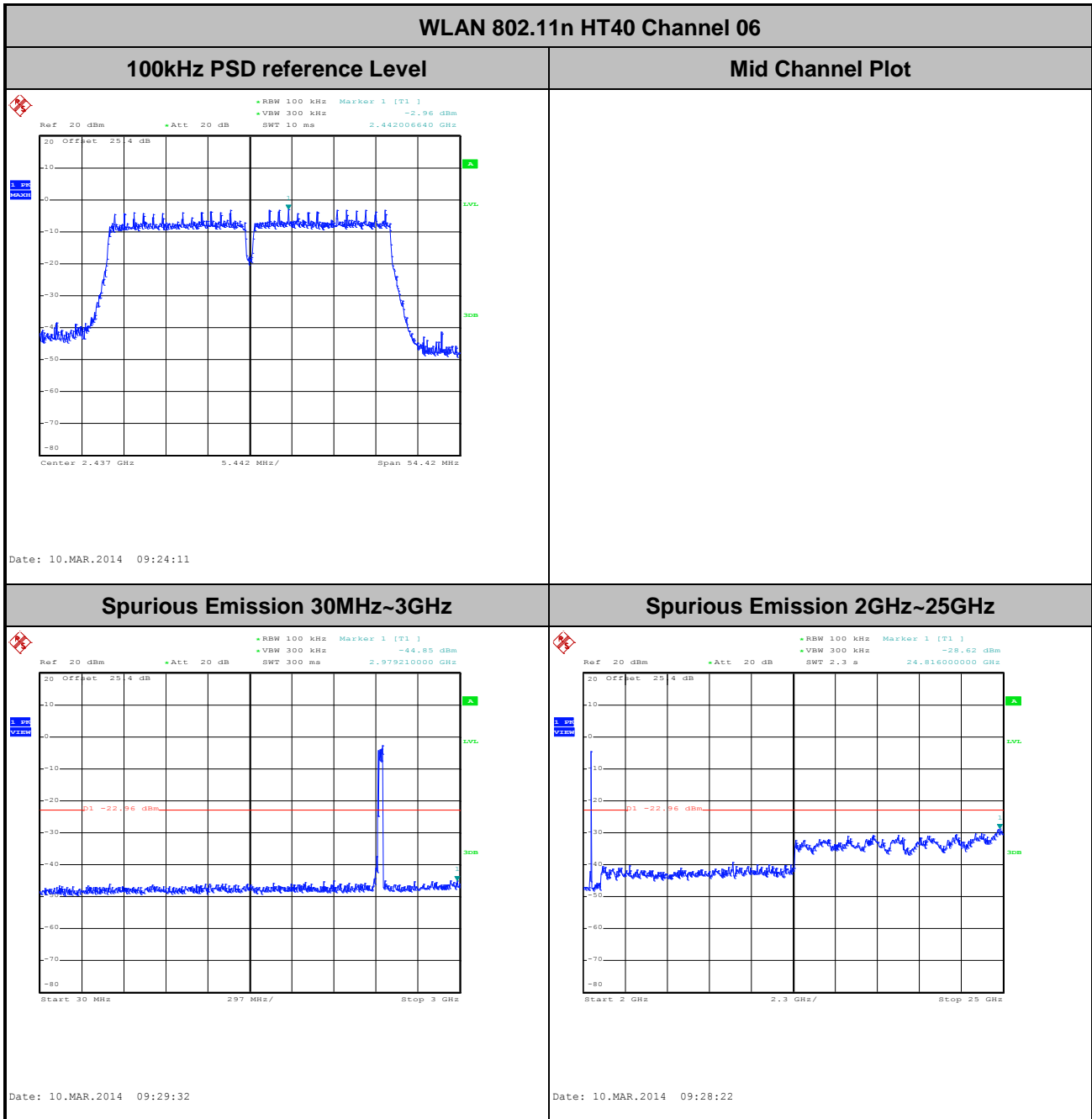





Test Mode :	802.11n HT40	Temperature :	21~25°C
Test Band :	2.4GHz High	Relative Humidity :	51~54%
Test Channel :	09	Test Engineer :	Alex Lee

WLAN 802.11n HT40 Channel 09

100kHz PSD reference Level

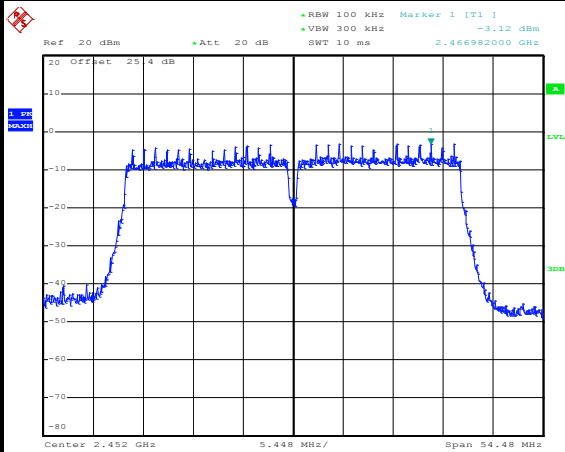

Date: 10.MAR.2014 09:33:31

High Channel Plot

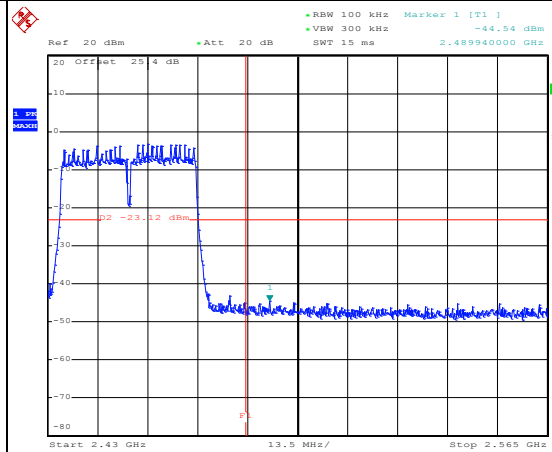

Date: 10.MAR.2014 09:33:45

Spurious Emission 30MHz~3GHz

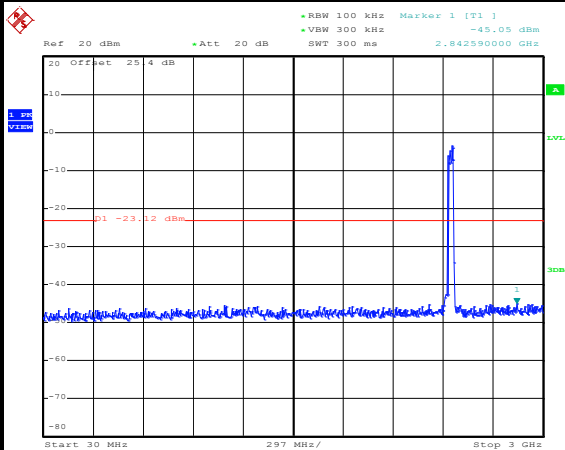

Date: 10.MAR.2014 09:41:21

Spurious Emission 2GHz~25GHz

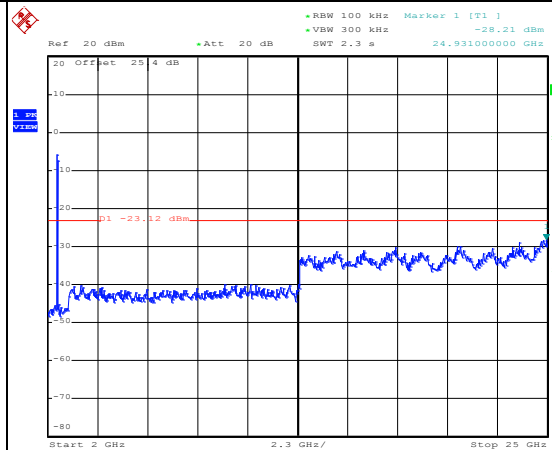

Date: 10.MAR.2014 09:40:47



Test Mode :	802.11a	Temperature :	21~25°C
Test Band :	5GHz Low	Relative Humidity :	51~54%
Test Channel :	149	Test Engineer :	Alex Lee

WLAN 802.11a Channel 149

100kHz PSD reference Level

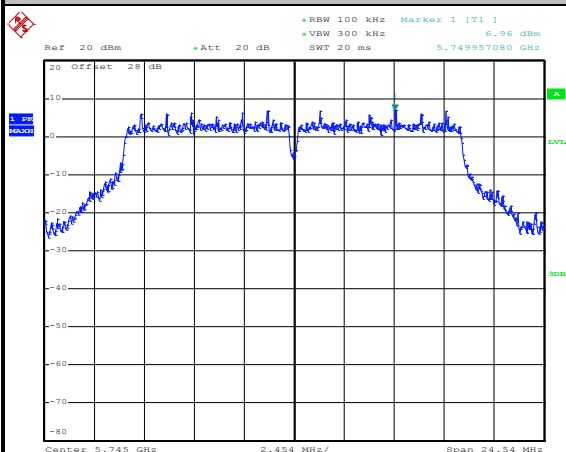

Date: 10.MAR.2014 10:53:10

Low Channel Plot

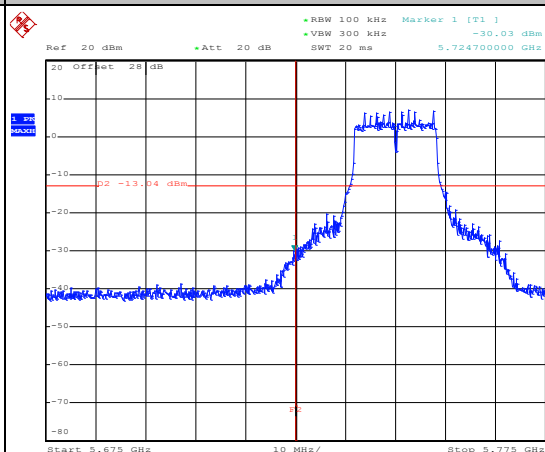

Date: 10.MAR.2014 10:53:24

Spurious Emission 30MHz~6GHz

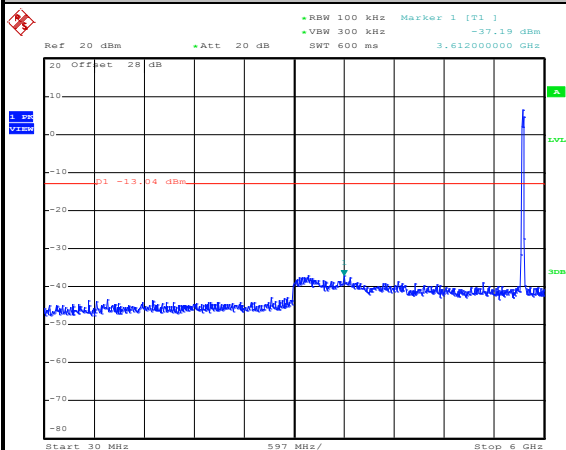

Date: 10.MAR.2014 10:55:09

Spurious Emission 5GHz~40GHz

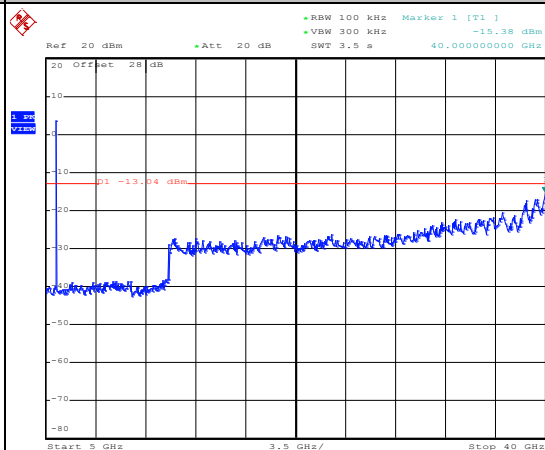

Date: 10.MAR.2014 10:55:27



Test Mode :	802.11a	Temperature :	21~25°C
Test Band :	5GHz Mid	Relative Humidity :	51~54%
Test Channel :	157	Test Engineer :	Alex Lee

WLAN 802.11a Channel 157

100kHz PSD reference Level

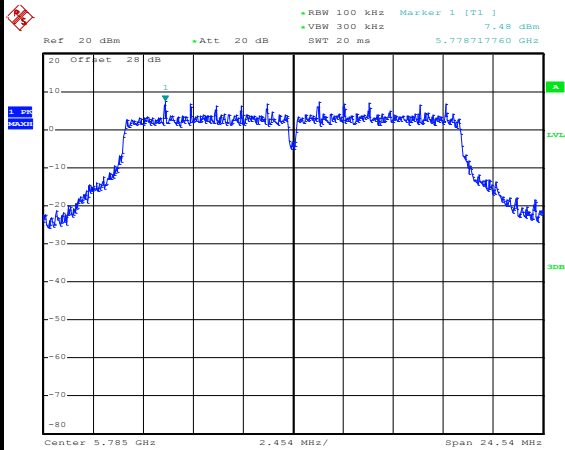

Date: 10.MAR.2014 11:00:50

Spurious Emission 30MHz~6GHz

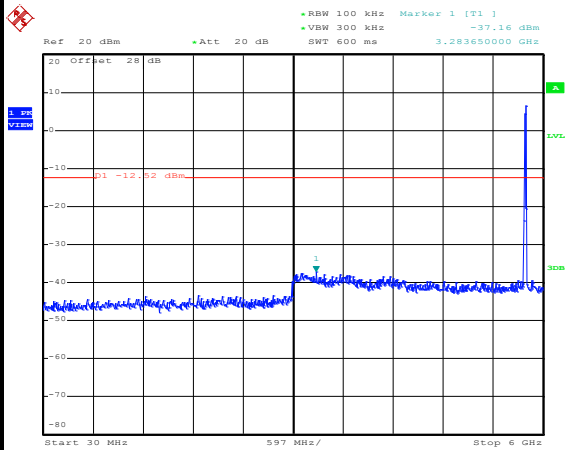

Date: 10.MAR.2014 11:01:10

Spurious Emission 5GHz~40GHz

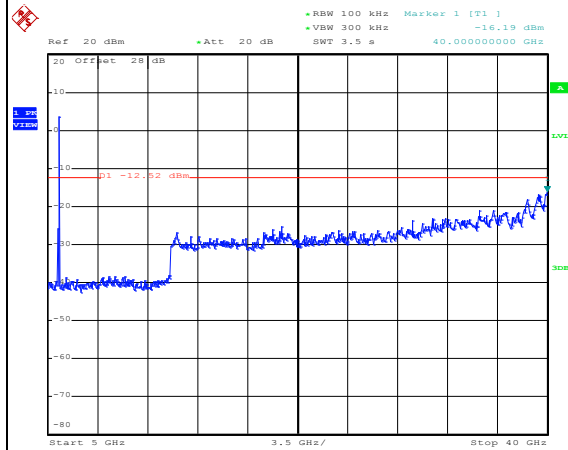

Date: 10.MAR.2014 11:01:28



Test Mode :	802.11a	Temperature :	21~25°C
Test Band :	5GHz High	Relative Humidity :	51~54%
Test Channel :	165	Test Engineer :	Alex Lee

WLAN 802.11a Channel 165

100kHz PSD reference Level

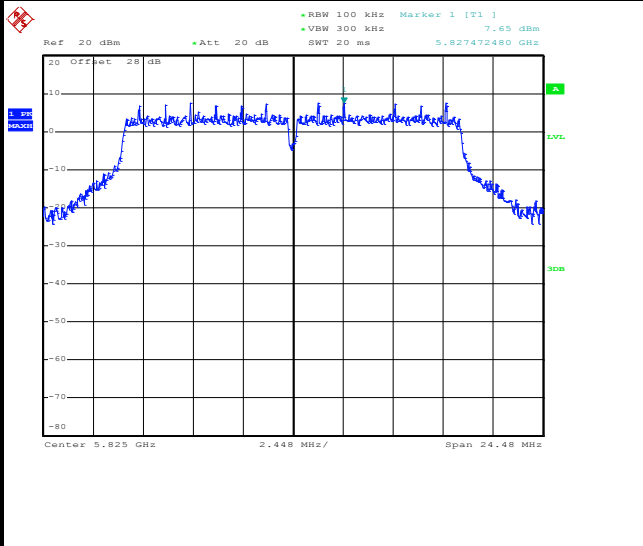

Date: 10.MAR.2014 11:04:01

High Channel Plot

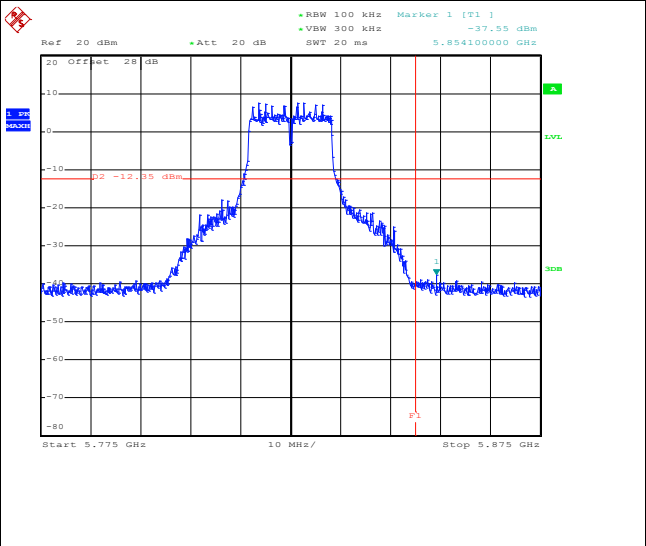

Date: 10.MAR.2014 11:04:15

Spurious Emission 30MHz~6GHz

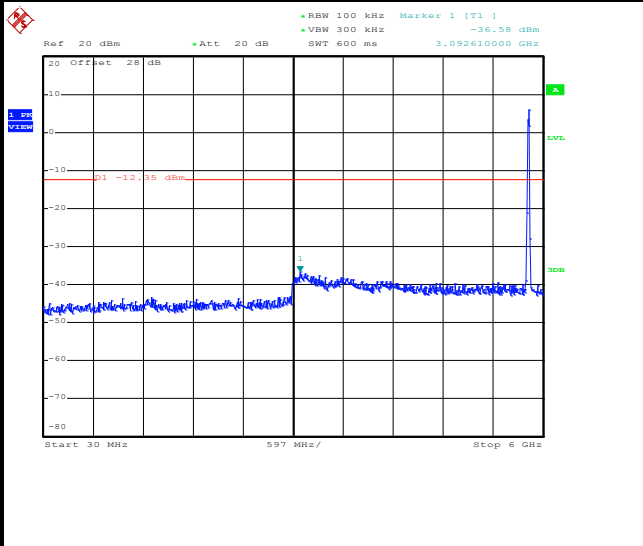

Date: 10.MAR.2014 11:04:34

Spurious Emission 5GHz~40GHz

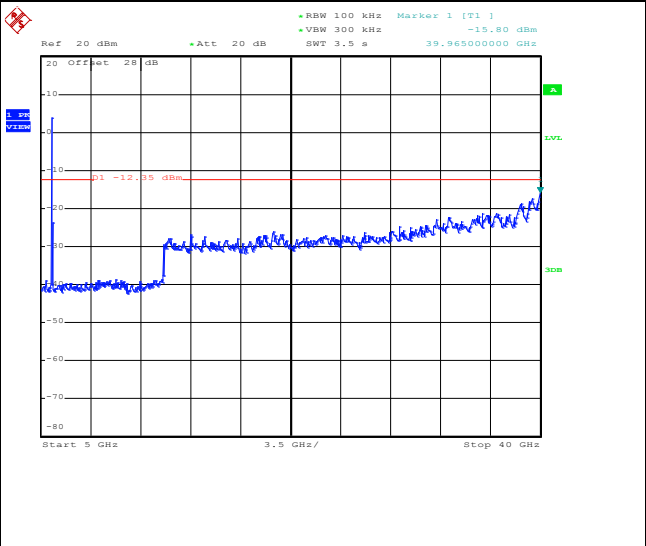

Date: 10.MAR.2014 11:04:53



Test Mode :	802.11n HT20	Temperature :	21~25°C
Test Band :	5GHz Low	Relative Humidity :	51~54%
Test Channel :	149	Test Engineer :	Alex Lee

WLAN 802.11n HT20 Channel 149

100kHz PSD reference Level

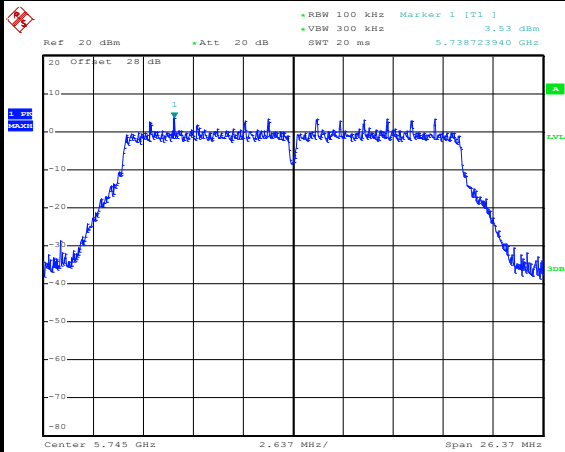

Date: 10.MAR.2014 11:17:20

Low Channel Plot

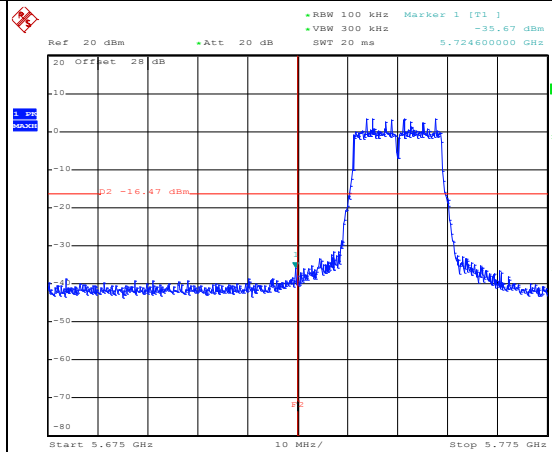

Date: 10.MAR.2014 11:17:33

Spurious Emission 30MHz~6GHz

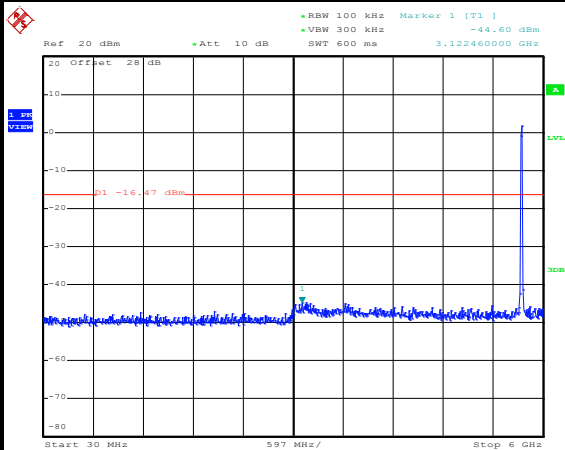

Date: 10.MAR.2014 11:17:53

Spurious Emission 5GHz~40GHz

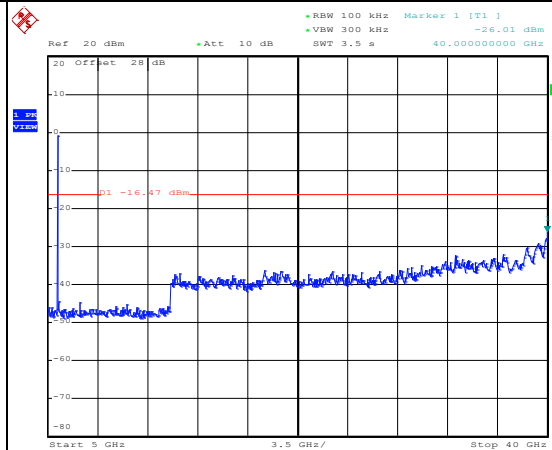

Date: 10.MAR.2014 11:18:11



Test Mode :	802.11n HT20	Temperature :	21~25°C
Test Band :	5GHz Mid	Relative Humidity :	51~54%
Test Channel :	157	Test Engineer :	Alex Lee

WLAN 802.11n HT20 Channel 157

100kHz PSD reference Level

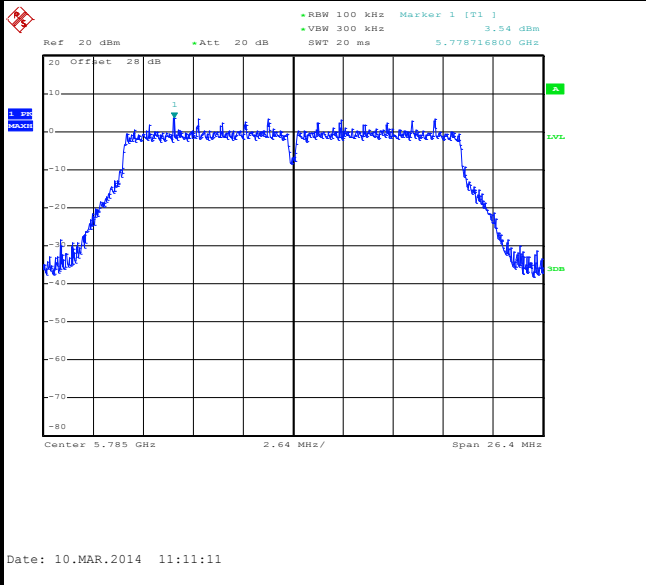

Spurious Emission 30MHz~6GHz

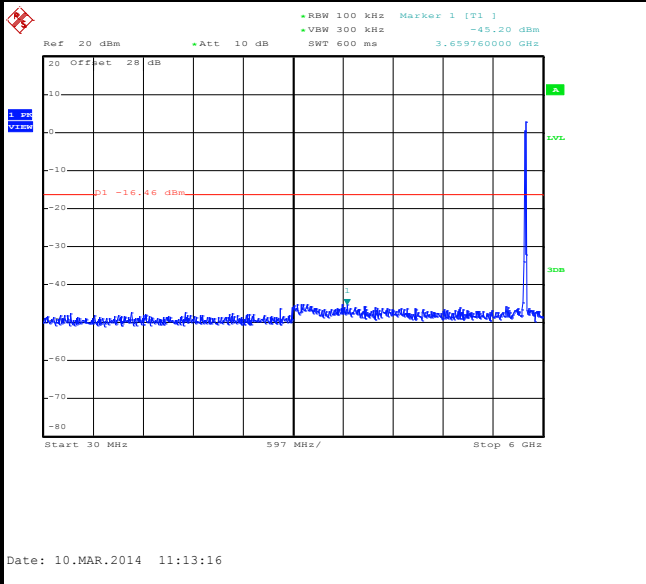

Spurious Emission 5GHz~40GHz

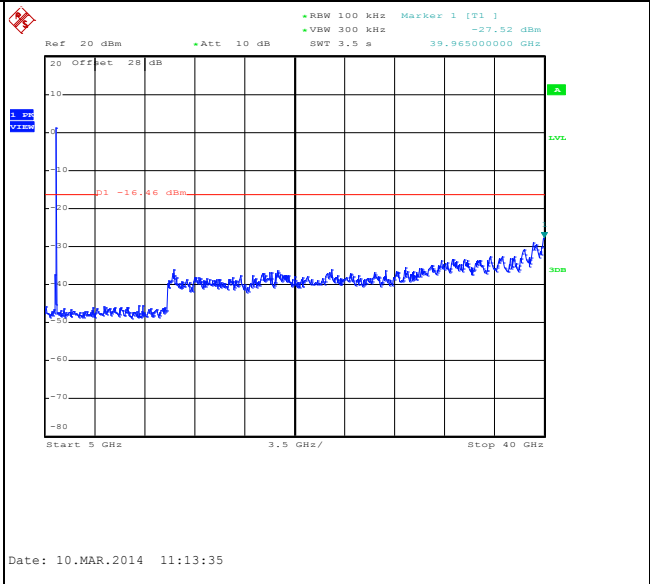



Test Mode :	802.11n HT20	Temperature :	21~25°C
Test Band :	5GHz High	Relative Humidity :	51~54%
Test Channel :	165	Test Engineer :	Alex Lee

WLAN 802.11n HT20 Channel 165

100kHz PSD reference Level

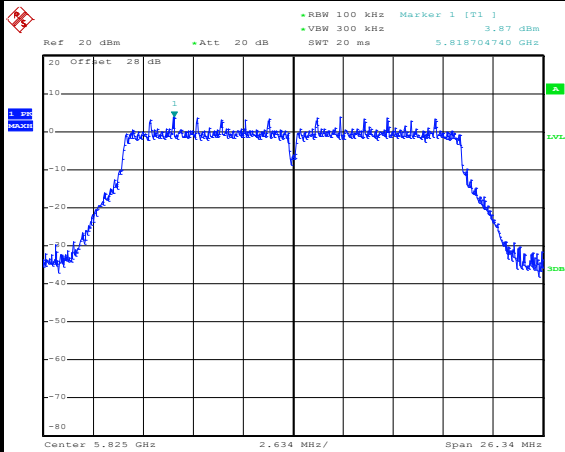

Date: 10.MAR.2014 11:07:40

High Channel Plot

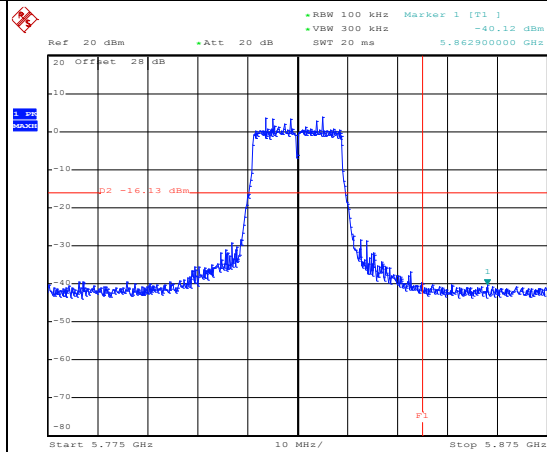

Date: 10.MAR.2014 11:07:54

Spurious Emission 30MHz~6GHz

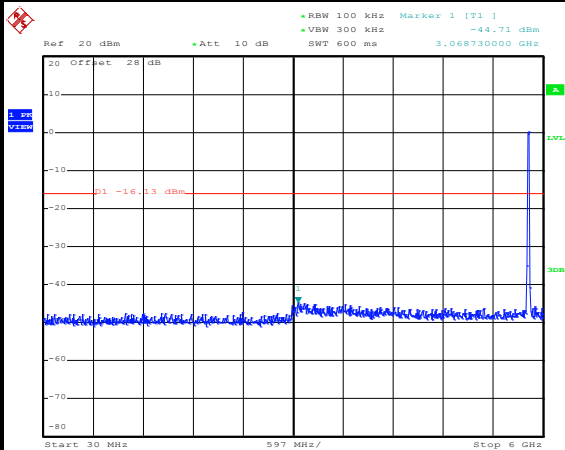

Date: 10.MAR.2014 11:14:23

Spurious Emission 5GHz~40GHz

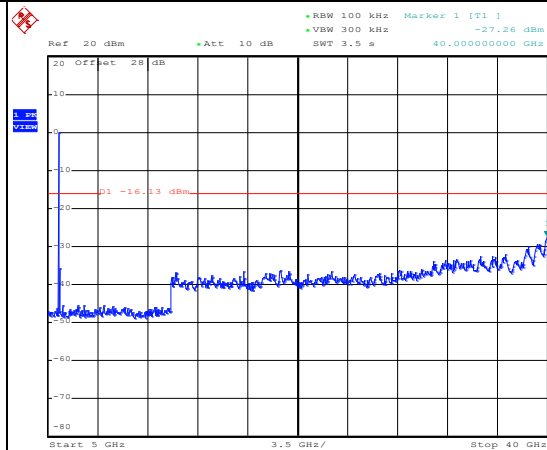

Date: 10.MAR.2014 11:14:42



Test Mode :	802.11n HT40	Temperature :	21~25°C
Test Band :	5GHz Low	Relative Humidity :	51~54%
Test Channel :	151	Test Engineer :	Alex Lee

WLAN 802.11n HT40 Channel 151

100kHz PSD reference Level

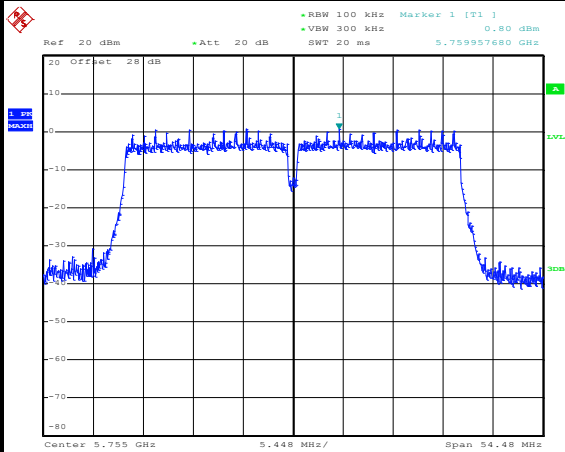

Date: 10.MAR.2014 11:21:40

Low Channel Plot

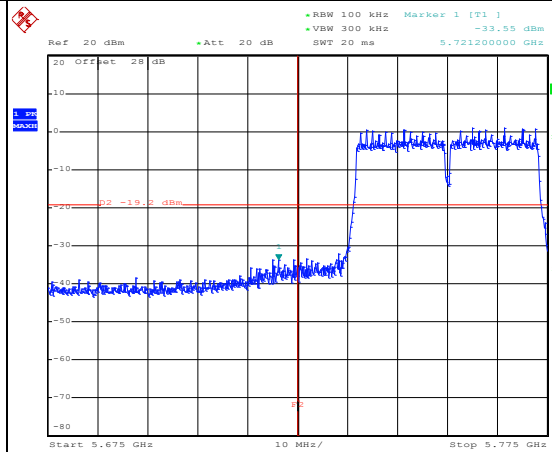

Date: 10.MAR.2014 11:21:54

Spurious Emission 30MHz~6GHz

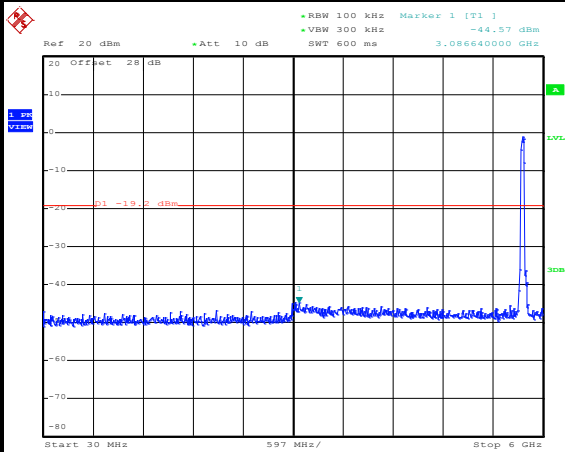

Date: 10.MAR.2014 11:22:13

Spurious Emission 5GHz~40GHz

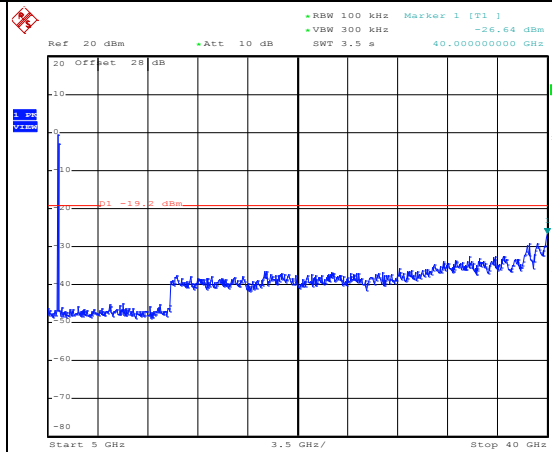

Date: 10.MAR.2014 11:22:32





Test Mode :	802.11n HT40	Temperature :	21~25°C
Test Band :	5GHz High	Relative Humidity :	51~54%
Test Channel :	159	Test Engineer :	Alex Lee

WLAN 802.11n HT40 Channel 159

100kHz PSD reference Level

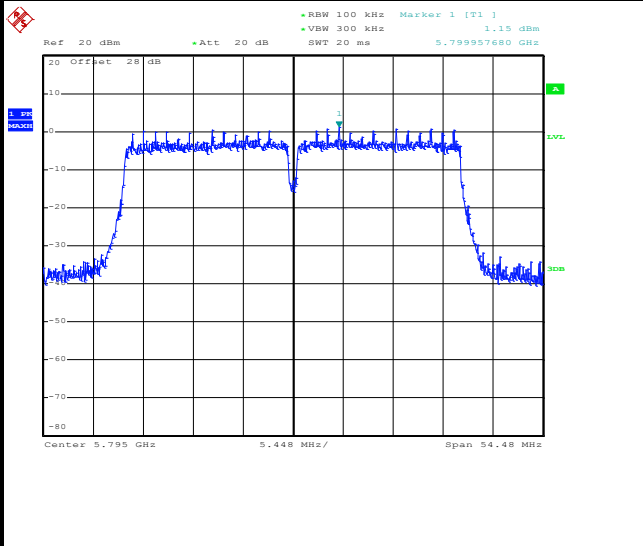

Date: 10.MAR.2014 11:25:07

High Channel Plot

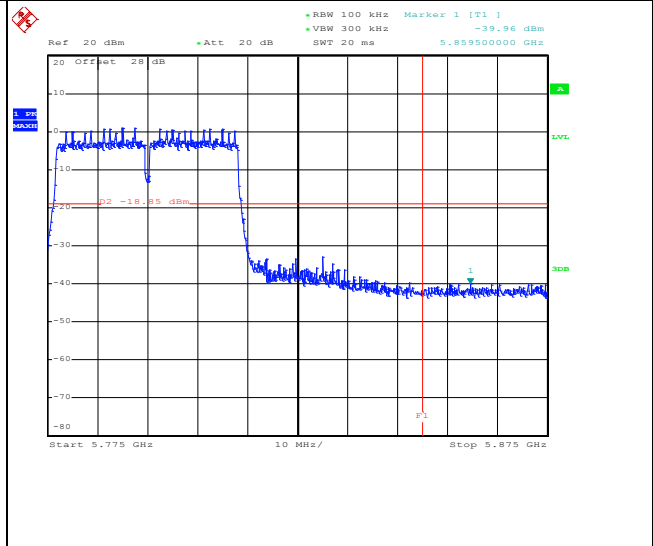

Date: 10.MAR.2014 11:25:21

Spurious Emission 30MHz~6GHz

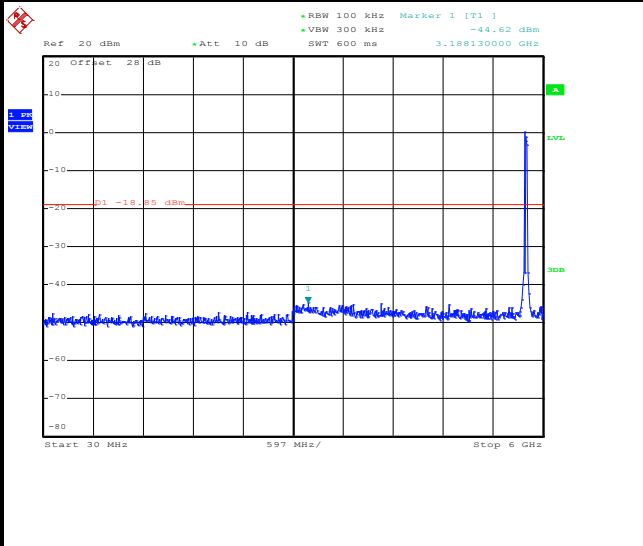

Date: 10.MAR.2014 11:25:40

Spurious Emission 5GHz~40GHz

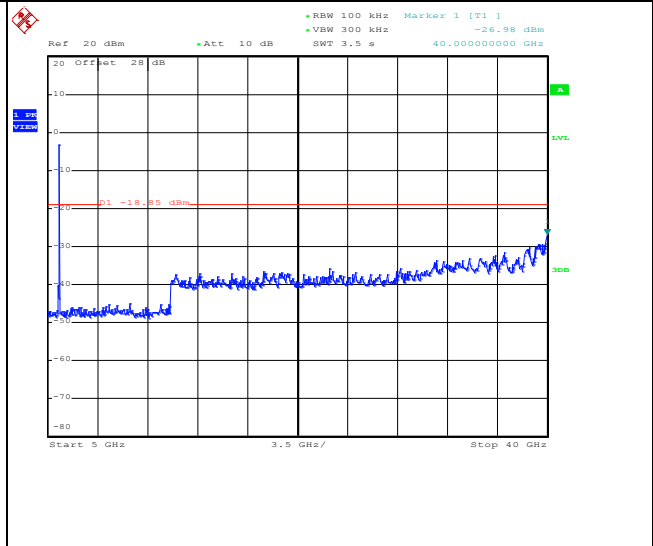

Date: 10.MAR.2014 11:25:59



Test Mode :	802.11ac VHT20	Temperature :	21~25°C
Test Band :	5GHz Low	Relative Humidity :	51~54%
Test Channel :	149	Test Engineer :	Alex Lee

WLAN 802.11n VHT20 Channel 149

100kHz PSD reference Level

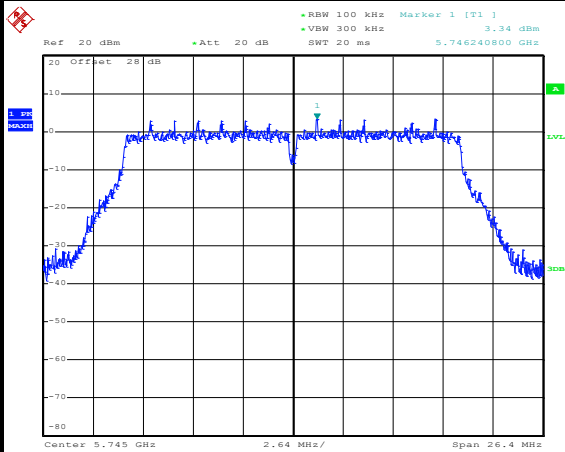

Date: 10.MAR.2014 11:41:32

Low Channel Plot

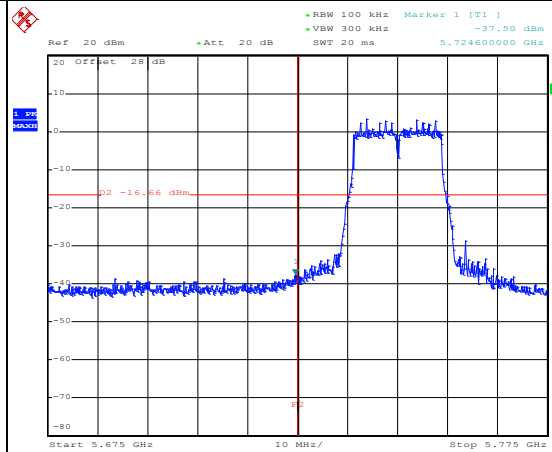

Date: 10.MAR.2014 11:41:45

Spurious Emission 30MHz~6GHz

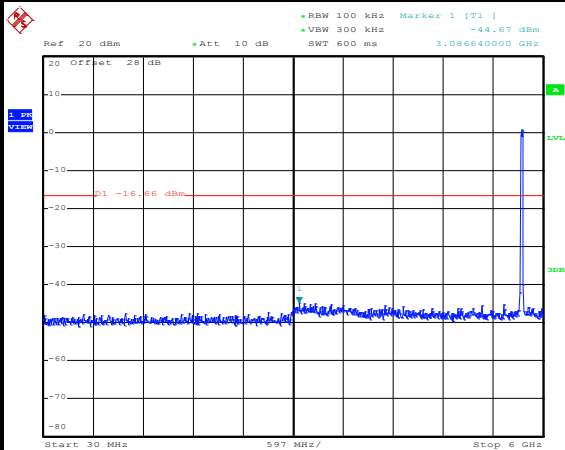

Date: 10.MAR.2014 11:42:05

Spurious Emission 5GHz~40GHz

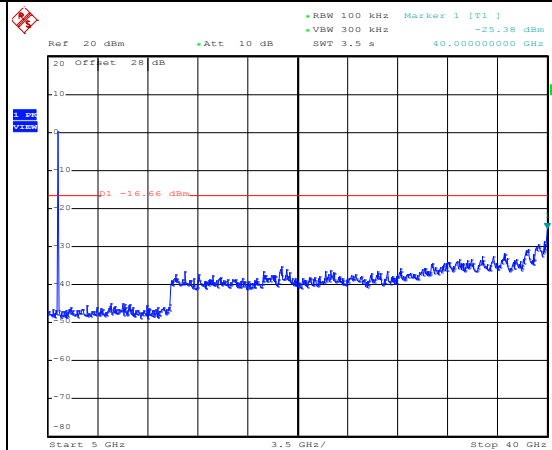

Date: 10.MAR.2014 11:42:23



Test Mode :	802.11ac VHT20	Temperature :	21~25°C
Test Band :	5GHz Mid	Relative Humidity :	51~54%
Test Channel :	157	Test Engineer :	Alex Lee

WLAN 802.11n VHT20 Channel 157

100kHz PSD reference Level

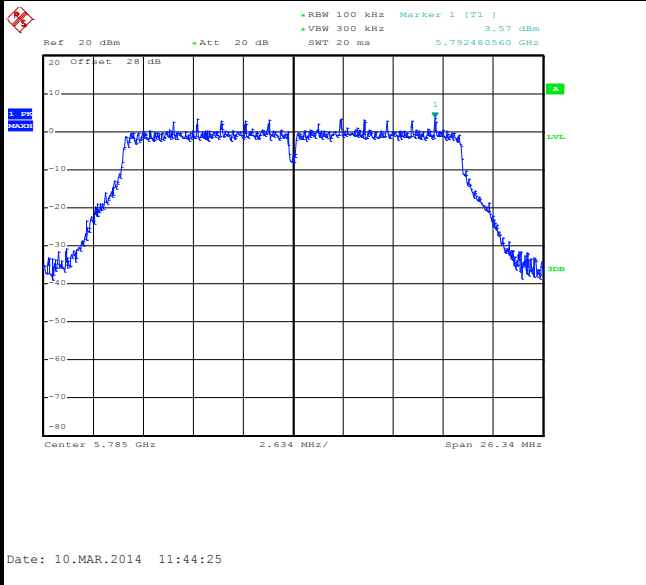

Spurious Emission 30MHz~6GHz

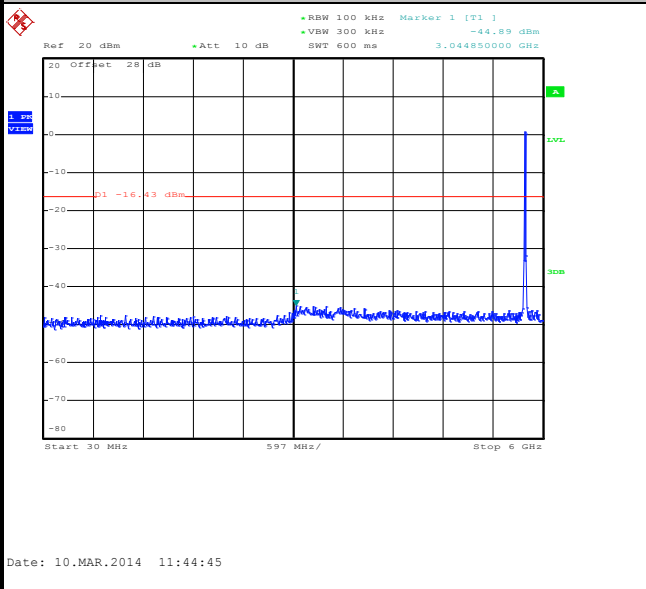

Spurious Emission 5GHz~40GHz

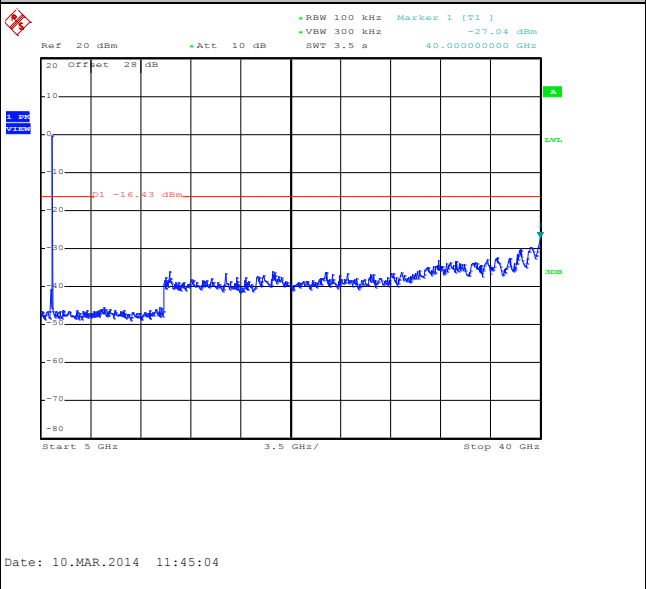



Test Mode :	802.11ac VHT20	Temperature :	21~25°C
Test Band :	5GHz High	Relative Humidity :	51~54%
Test Channel :	165	Test Engineer :	Alex Lee

WLAN 802.11n VHT20 Channel 165

100kHz PSD reference Level

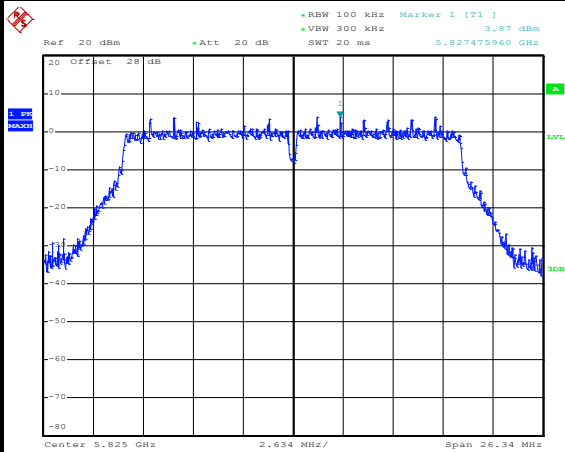

Date: 10.MAR.2014 11:46:59

High Channel Plot

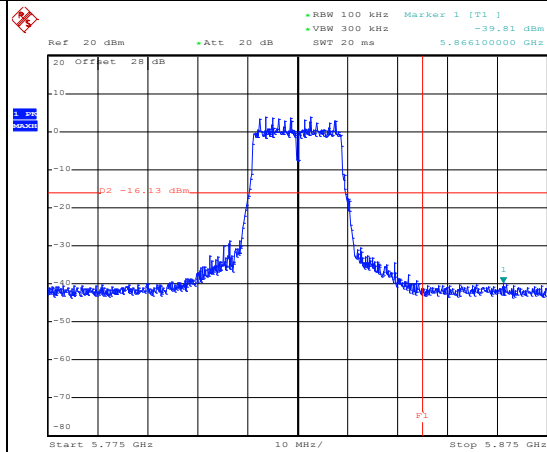

Date: 10.MAR.2014 11:47:13

Spurious Emission 30MHz~6GHz

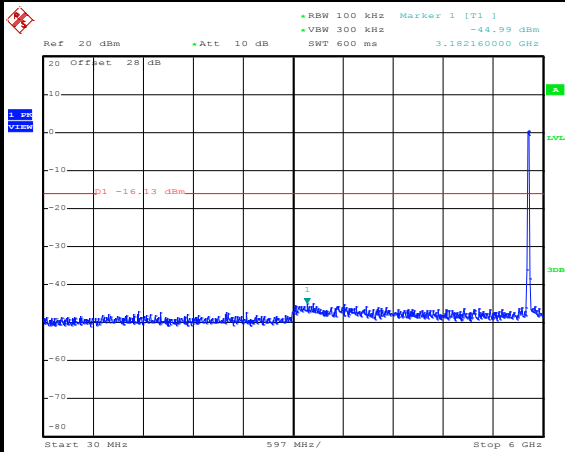

Date: 10.MAR.2014 11:47:32

Spurious Emission 5GHz~40GHz

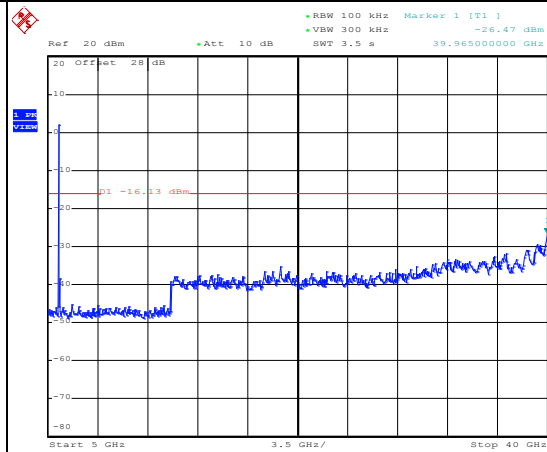

Date: 10.MAR.2014 11:47:51



Test Mode :	802.11ac VHT40	Temperature :	21~25°C
Test Band :	5GHz Low	Relative Humidity :	51~54%
Test Channel :	151	Test Engineer :	Alex Lee

WLAN 802.11n VHT40 Channel 151

100kHz PSD reference Level

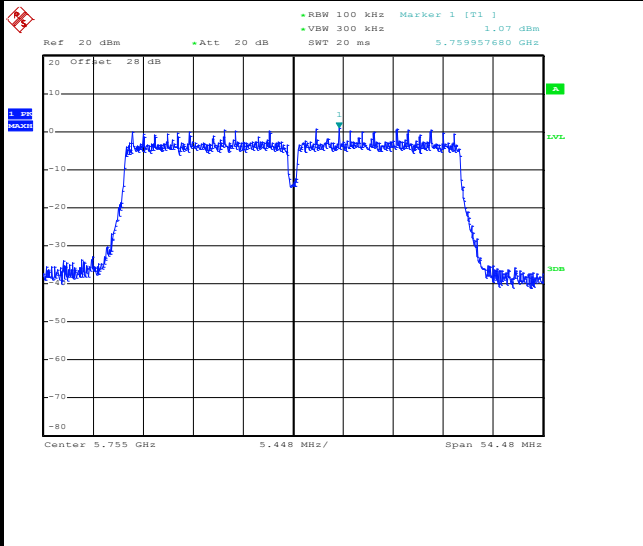

Date: 10.MAR.2014 11:37:27

Low Channel Plot

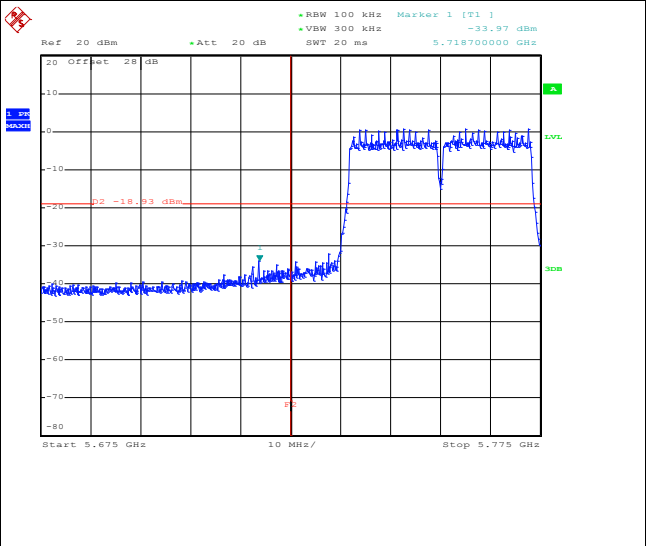

Date: 10.MAR.2014 11:37:40

Spurious Emission 30MHz~6GHz

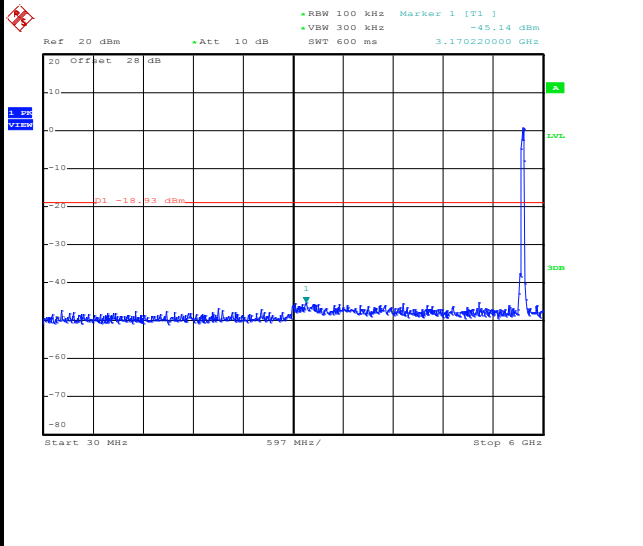

Date: 10.MAR.2014 11:38:00

Spurious Emission 5GHz~40GHz

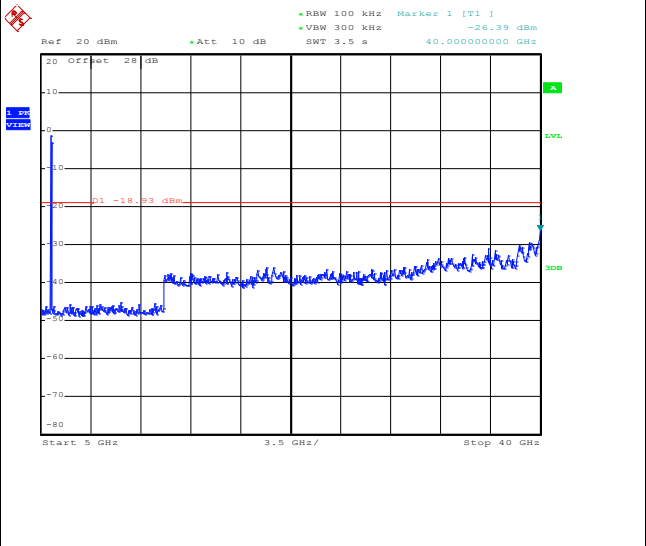

Date: 10.MAR.2014 11:38:18



Test Mode :	802.11ac VHT40	Temperature :	21~25°C
Test Band :	5GHz High	Relative Humidity :	51~54%
Test Channel :	159	Test Engineer :	Alex Lee

WLAN 802.11n VHT40 Channel 159

100kHz PSD reference Level

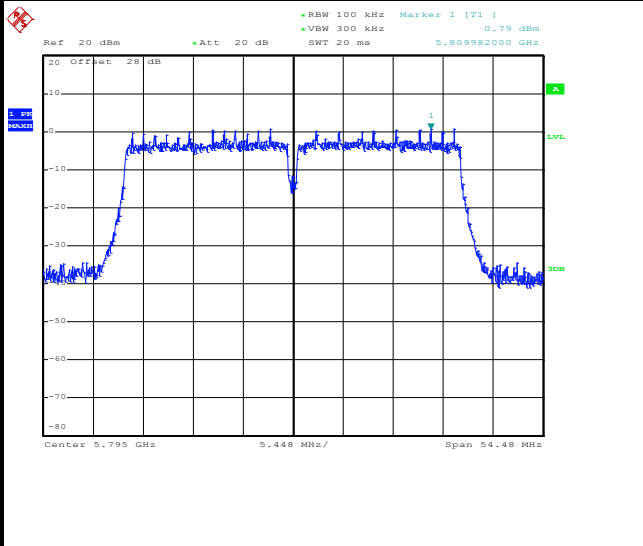

Date: 10.MAR.2014 11:33:44

High Channel Plot

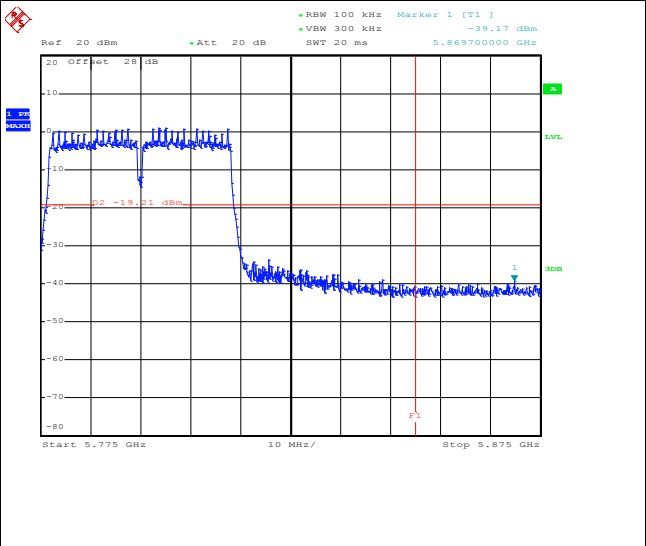

Date: 10.MAR.2014 11:33:58

Spurious Emission 30MHz~6GHz

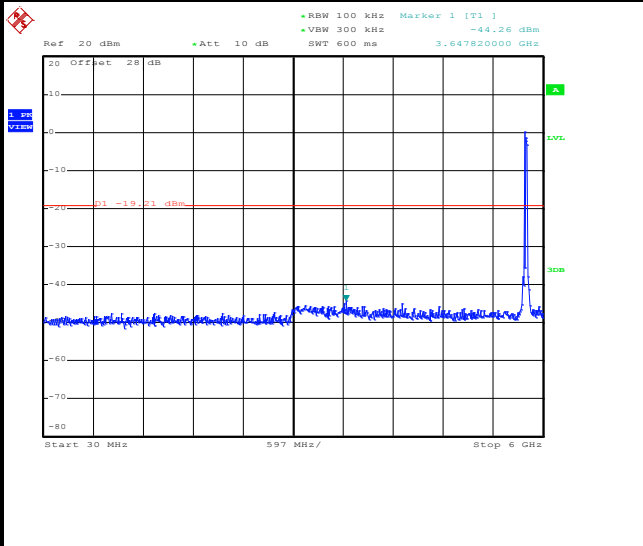

Date: 10.MAR.2014 11:34:17

Spurious Emission 5GHz~40GHz

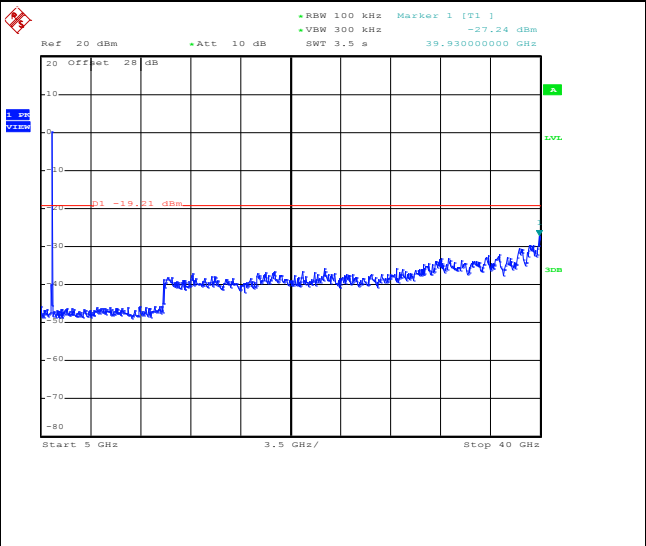

Date: 10.MAR.2014 11:34:36



Test Mode :	802.11ac VHT80	Temperature :	21~25°C
Test Band :	5GHz Middle	Relative Humidity :	51~54%
Test Channel :	155	Test Engineer :	Alex Lee

WLAN 802.11n VHT80 Channel 155

100kHz PSD reference Level

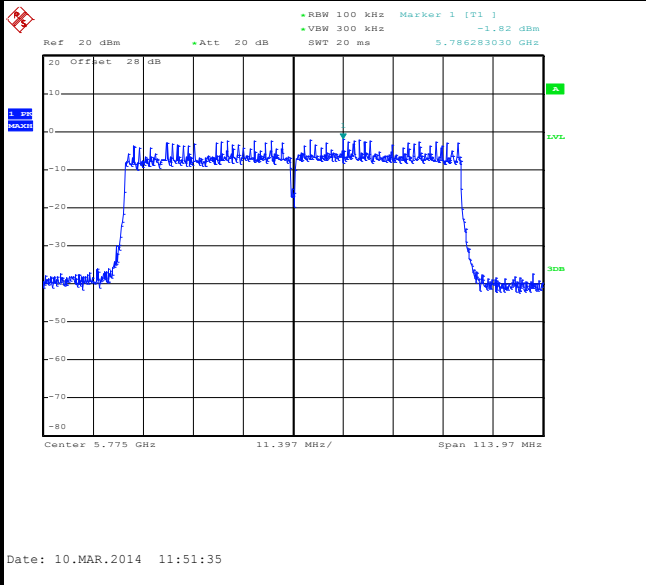

Spurious Emission 30MHz~6GHz

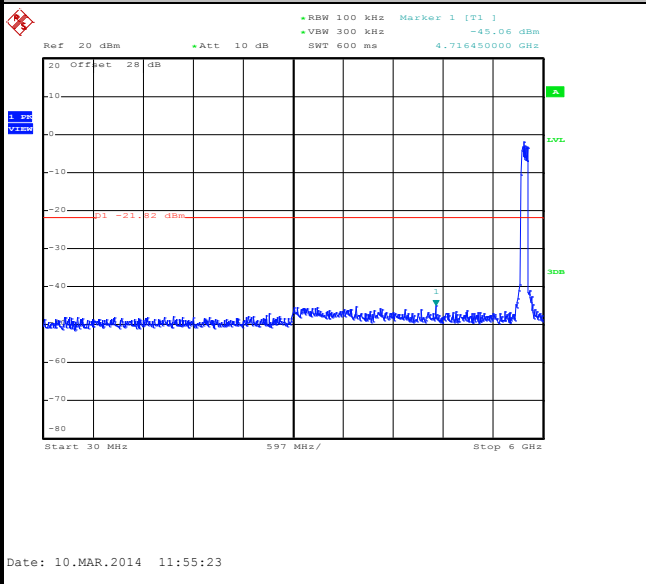

Spurious Emission 5GHz~40GHz

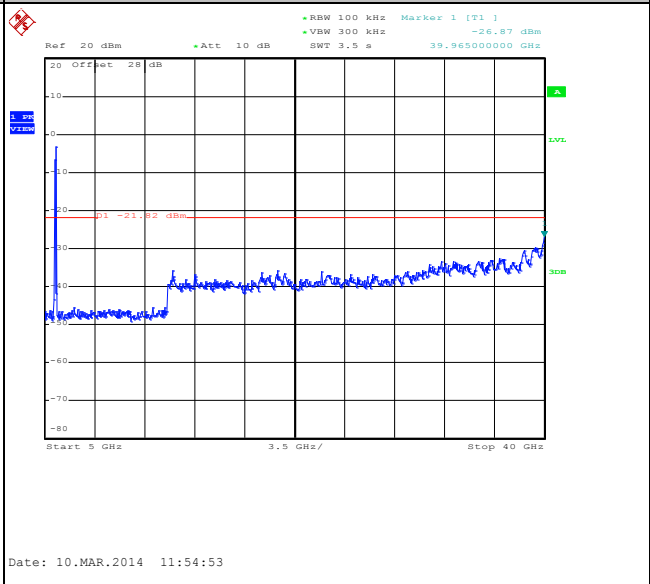



Test Mode :	802.11ac VHT80	Temperature :	21~25°C
Test Band :	5GHz Middle	Relative Humidity :	51~54%
Test Channel :	155	Test Engineer :	Alex Lee

WLAN 802.11n VHT80 Channel 155

Middle Channel Plot

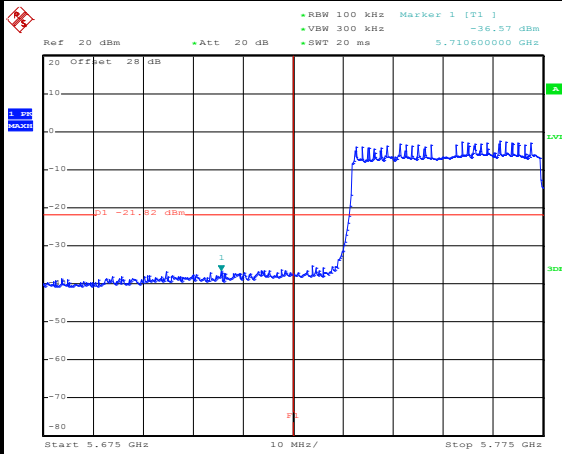

Date: 10.MAR.2014 11:57:52

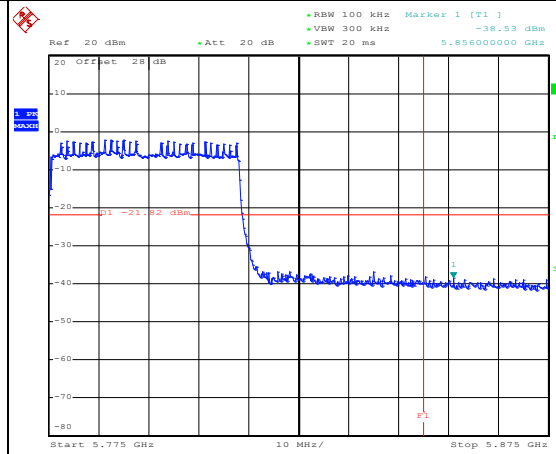

Date: 10.MAR.2014 11:58:37



### 3.5 Radiated Band Edges and Spurious Emission Measurement

#### 3.5.1 Limit of Radiated band edge and Spurious Emission Measurement

In any 100 kHz bandwidth outside the intentional radiator frequency band, all harmonics/spurious must be at least 20 dB below the highest emission level within the authorized band. If the output power of this device was measured by spectrum analyzer, the attenuation under this paragraph shall be 30 dB instead of 20 dB. In addition, radiated emissions which fall in the restricted bands must also comply with the FCC section 15.209 limits as below.

Frequency (MHz)	Field Strength (microvolts/meter)	Measurement Distance (meters)
0.009 – 0.490	2400/F(kHz)	300
0.490 – 1.705	24000/F(kHz)	30
1.705 – 30.0	30	30
30 – 88	100	3
88 – 216	150	3
216 - 960	200	3
Above 960	500	3

#### 3.5.2 Measuring Instruments

The measuring equipment is listed in the section 4 of this test report.



### 3.5.3 Test Procedures

1. The testing follows FCC KDB Publication No. 558074 D01 DTS Meas. Guidance v03r01.
2. The EUT was arranged to its worst case and then tune the antenna tower (from 1 m to 4 m) and turntable (from 0 degree to 360 degrees) to find the maximum reading. A pre-amp and a high pass filter are used for the test in order to get better signal level.
3. The EUT was placed on a turntable with 0.8 meter above ground.
4. The EUT was set 3 meters from the interference receiving antenna, which was mounted on the top of a variable height antenna tower.
5. Corrected Reading: Antenna Factor + Cable Loss + Read Level - Preamp Factor = Level
6. For measurement below 1GHz, If the emission level of the EUT measured by the peak detector is 3 dB lower than the applicable limit, the peak emission level will be reported. Otherwise, the emission measurement will be repeated using the quasi-peak detector and reported.
7. Use the following spectrum analyzer settings:
  - (1) Span shall wide enough to fully capture the emission being measured;
  - (2) Set RBW=100 kHz for  $f < 1$  GHz;  $VBW \geq RBW$ ; Sweep = auto; Detector function = peak; Trace = max hold;
  - (3) Set RBW = 1 MHz, VBW= 3MHz for  $f \geq 1$  GHz for peak measurement.  
For average measurement:
    - $VBW = 10$  Hz, when duty cycle is no less than 98 percent.
    - $VBW \geq 1/T$ , when duty cycle is less than 98 percent where T is the minimum transmission duration over which the transmitter is on and is transmitting at its maximum power control level for the tested mode of operation.



Band	Duty Cycle(%)	T(μs)	1/T(kHz)	VBW Setting
802.11b	98.1	-	-	10Hz
802.11g	88.79	2060	0.48	1kHz
2.4GHz 802.11n HT20	88.53	1930	0.52	1kHz
2.4GHz 802.11n HT40	79.17	950	1.05	3kHz
802.11a	88.84	2070	0.48	1kHz
5GHz 802.11n HT20	88.53	1930	0.52	1kHz
5GHz 802.11n HT40	78.99	940	1.06	3kHz
5GHz 802.11n VHT20	88.58	1940	0.52	1kHz
5GHz 802.11n VHT40	79.34	960	1.04	3kHz
5GHz 802.11n VHT80	65.28	470	2.13	3kHz

### 3.5.4 Test Setup

For radiated emissions below 30MHz

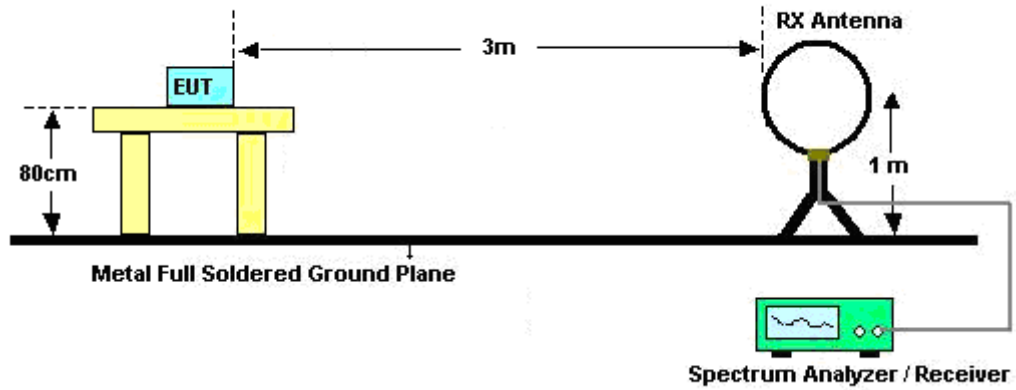

For radiated emissions from 30MHz to 1GHz

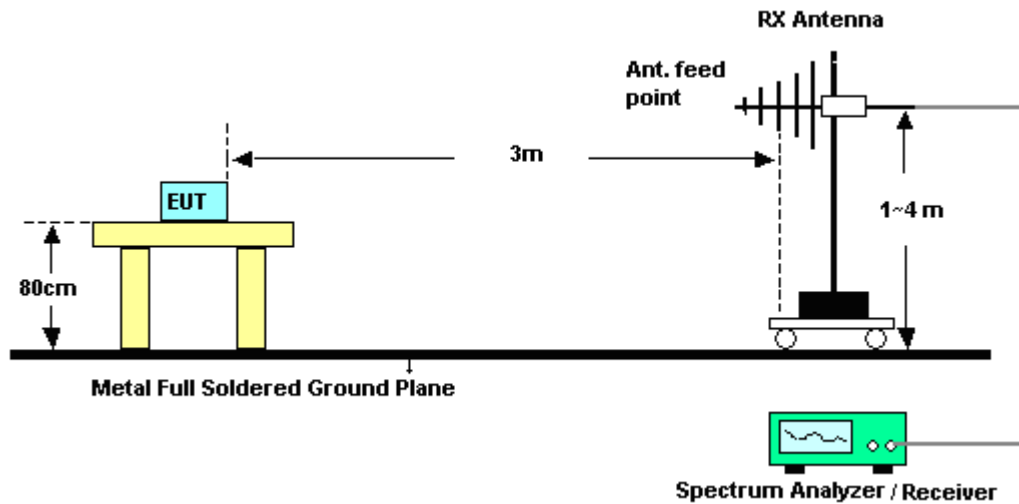

For radiated emissions above 1GHz

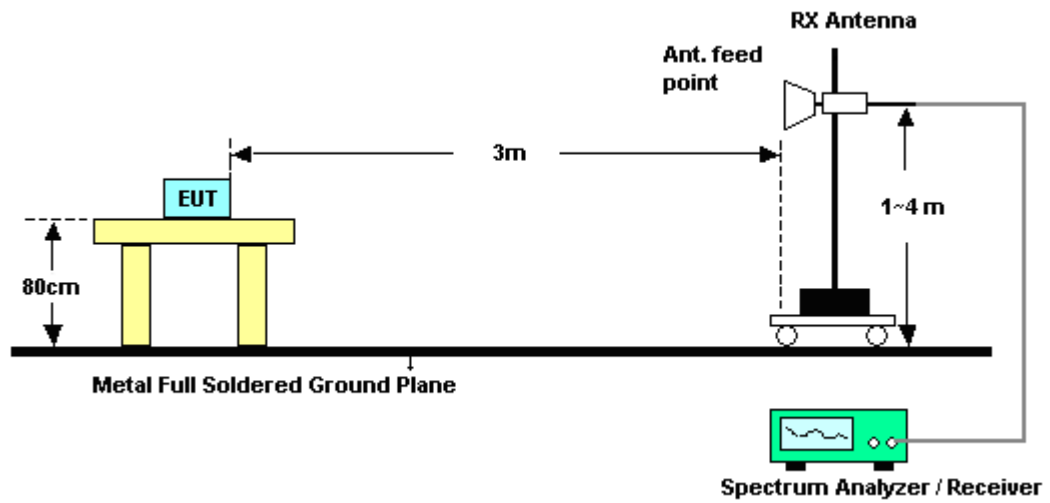

### 3.5.5 Test Results of Radiated Spurious Emissions (9kHz ~ 30MHz)

The low frequency, which started from 9 kHz to 30MHz, was pre-scanned and the result which was 20dB lower than the limit line per 15.31(o) was not reported.



3.5.6 Test Result of Radiated Spurious at Band Edges

Test Mode :	802.11b	Temperature :	22~24°C
Test Band :	Low	Relative Humidity :	50~52%
Test Channel :	01	Test Engineer :	Kyle Jhuang

ANTENNA POLARITY : HORIZONTAL										
Frequency ( MHz )	Level ( dBμV/m )	Over Limit ( dB )	Limit Line ( dBμV/m )	Read Level ( dBμV )	Antenna Factor ( dB )	Cable Loss ( dB )	Preamp Factor ( dB )	Ant Pos ( cm )	Table Pos ( deg )	Remark
2389.38	70.1	-3.9	74	67.12	32.29	6.22	35.53	100	188	Peak
2390	52.02	-1.98	54	49.01	32.29	6.22	35.5	100	188	Average

ANTENNA POLARITY : VERTICAL										
Frequency ( MHz )	Level ( dBμV/m )	Over Limit ( dB )	Limit Line ( dBμV/m )	Read Level ( dBμV )	Antenna Factor ( dB )	Cable Loss ( dB )	Preamp Factor ( dB )	Ant Pos ( cm )	Table Pos ( deg )	Remark
2381.64	61.51	-12.49	74	58.56	32.26	6.22	35.53	152	54	Peak
2390	46	-8	54	42.99	32.29	6.22	35.5	152	54	Average

Test Mode :	802.11b	Temperature :	22~24°C
Test Band :	High	Relative Humidity :	50~52%
Test Channel :	11	Test Engineer :	Kyle Jhuang

ANTENNA POLARITY : HORIZONTAL										
Frequency ( MHz )	Level ( dBμV/m )	Over Limit ( dB )	Limit Line ( dBμV/m )	Read Level ( dBμV )	Antenna Factor ( dB )	Cable Loss ( dB )	Preamp Factor ( dB )	Ant Pos ( cm )	Table Pos ( deg )	Remark
2484.19	70.7	-3.3	74	67.21	32.47	6.45	35.43	123	184	Peak
2486.74	50.1	-3.9	54	46.61	32.47	6.45	35.43	123	184	Average

ANTENNA POLARITY : VERTICAL										
Frequency ( MHz )	Level ( dBμV/m )	Over Limit ( dB )	Limit Line ( dBμV/m )	Read Level ( dBμV )	Antenna Factor ( dB )	Cable Loss ( dB )	Preamp Factor ( dB )	Ant Pos ( cm )	Table Pos ( deg )	Remark
2483.62	59.16	-14.84	74	55.67	32.47	6.45	35.43	149	49	Peak
2483.5	40.82	-13.18	54	37.33	32.47	6.45	35.43	149	49	Average



Test Mode :	802.11g	Temperature :	22~24°C
Test Band :	Low	Relative Humidity :	50~52%
Test Channel :	01	Test Engineer :	Kyle Jhuang

ANTENNA POLARITY : HORIZONTAL										
Frequency ( MHz )	Level ( dBμV/m )	Over Limit ( dB )	Limit Line ( dBμV/m )	Read Level ( dBμV )	Antenna Factor ( dB )	Cable Loss ( dB )	Preamp Factor ( dB )	Ant Pos ( cm )	Table Pos ( deg )	Remark
2389.74	73.74	-0.26	74	70.76	32.29	6.22	35.53	100	187	Peak
2390	52.98	-1.02	54	49.97	32.29	6.22	35.5	100	187	Average

ANTENNA POLARITY : VERTICAL										
Frequency ( MHz )	Level ( dBμV/m )	Over Limit ( dB )	Limit Line ( dBμV/m )	Read Level ( dBμV )	Antenna Factor ( dB )	Cable Loss ( dB )	Preamp Factor ( dB )	Ant Pos ( cm )	Table Pos ( deg )	Remark
2389.2	63.98	-10.02	74	61	32.29	6.22	35.53	180	49	Peak
2390	42.03	-11.97	54	39.02	32.29	6.22	35.5	180	49	Average

Test Mode :	802.11g	Temperature :	22~24°C
Test Band :	High	Relative Humidity :	50~52%
Test Channel :	11	Test Engineer :	Kyle Jhuang

ANTENNA POLARITY : HORIZONTAL										
Frequency ( MHz )	Level ( dBμV/m )	Over Limit ( dB )	Limit Line ( dBμV/m )	Read Level ( dBμV )	Antenna Factor ( dB )	Cable Loss ( dB )	Preamp Factor ( dB )	Ant Pos ( cm )	Table Pos ( deg )	Remark
2483.8	72.51	-1.49	74	69.02	32.47	6.45	35.43	121	187	Peak
2483.5	51.45	-2.55	54	47.96	32.47	6.45	35.43	121	187	Average

ANTENNA POLARITY : VERTICAL										
Frequency ( MHz )	Level ( dBμV/m )	Over Limit ( dB )	Limit Line ( dBμV/m )	Read Level ( dBμV )	Antenna Factor ( dB )	Cable Loss ( dB )	Preamp Factor ( dB )	Ant Pos ( cm )	Table Pos ( deg )	Remark
2483.71	64.32	-9.68	74	60.83	32.47	6.45	35.43	146	48	Peak
2483.56	40.65	-13.35	54	37.16	32.47	6.45	35.43	146	48	Average



Test Mode :	802.11n HT20	Temperature :	22~24°C
Test Band :	Low	Relative Humidity :	50~52%
Test Channel :	01	Test Engineer :	Kyle Jhuang

ANTENNA POLARITY : HORIZONTAL										
Frequency ( MHz )	Level ( dBμV/m )	Over Limit ( dB )	Limit Line ( dBμV/m )	Read Level ( dBμV )	Antenna Factor ( dB )	Cable Loss ( dB )	Preamp Factor ( dB )	Ant Pos ( cm )	Table Pos ( deg )	Remark
2388.48	73.3	-0.7	74	70.32	32.29	6.22	35.53	100	186	Peak
2390	49.78	-4.22	54	46.77	32.29	6.22	35.5	100	186	Average

ANTENNA POLARITY : VERTICAL										
Frequency ( MHz )	Level ( dBμV/m )	Over Limit ( dB )	Limit Line ( dBμV/m )	Read Level ( dBμV )	Antenna Factor ( dB )	Cable Loss ( dB )	Preamp Factor ( dB )	Ant Pos ( cm )	Table Pos ( deg )	Remark
2387.85	66.58	-7.42	74	63.6	32.29	6.22	35.53	152	50	Peak
2390	45.4	-8.6	54	42.39	32.29	6.22	35.5	152	50	Average

Test Mode :	802.11n HT20	Temperature :	22~24°C
Test Band :	High	Relative Humidity :	50~52%
Test Channel :	11	Test Engineer :	Kyle Jhuang

ANTENNA POLARITY : HORIZONTAL										
Frequency ( MHz )	Level ( dBμV/m )	Over Limit ( dB )	Limit Line ( dBμV/m )	Read Level ( dBμV )	Antenna Factor ( dB )	Cable Loss ( dB )	Preamp Factor ( dB )	Ant Pos ( cm )	Table Pos ( deg )	Remark
2486.26	73.43	-0.57	74	69.94	32.47	6.45	35.43	123	183	Peak
2483.71	48.01	-5.99	54	44.52	32.47	6.45	35.43	123	183	Average

ANTENNA POLARITY : VERTICAL										
Frequency ( MHz )	Level ( dBμV/m )	Over Limit ( dB )	Limit Line ( dBμV/m )	Read Level ( dBμV )	Antenna Factor ( dB )	Cable Loss ( dB )	Preamp Factor ( dB )	Ant Pos ( cm )	Table Pos ( deg )	Remark
2487.22	62.74	-11.26	74	59.25	32.47	6.45	35.43	146	50	Peak
2484.19	44.94	-9.06	54	41.45	32.47	6.45	35.43	146	50	Average





Test Mode :	802.11n HT40	Temperature :	22~24°C
Test Band :	Low	Relative Humidity :	50~52%
Test Channel :	03	Test Engineer :	Kyle Jhuang

ANTENNA POLARITY : HORIZONTAL										
Frequency ( MHz )	Level ( dBμV/m )	Over Limit ( dB )	Limit Line ( dBμV/m )	Read Level ( dBμV )	Antenna Factor ( dB )	Cable Loss ( dB )	Preamp Factor ( dB )	Ant Pos ( cm )	Table Pos ( deg )	Remark
2386.41	66.27	-7.73	74	63.29	32.29	6.22	35.53	100	186	Peak
2389.92	52.9	-1.1	54	49.89	32.29	6.22	35.5	100	186	Average
2484.04	58.54	-15.46	74	55.05	32.47	6.45	35.43	100	186	Peak
2488.18	46.26	-7.74	54	42.74	32.5	6.45	35.43	100	186	Average

ANTENNA POLARITY : VERTICAL										
Frequency ( MHz )	Level ( dBμV/m )	Over Limit ( dB )	Limit Line ( dBμV/m )	Read Level ( dBμV )	Antenna Factor ( dB )	Cable Loss ( dB )	Preamp Factor ( dB )	Ant Pos ( cm )	Table Pos ( deg )	Remark
2387.94	58.39	-15.61	74	55.41	32.29	6.22	35.53	180	52	Peak
2389.74	46.6	-7.4	54	43.62	32.29	6.22	35.53	180	52	Average
2491.36	58.28	-15.72	74	54.76	32.5	6.45	35.43	180	52	Peak
2490.73	45.21	-8.79	54	41.69	32.5	6.45	35.43	180	52	Average



Test Mode :	802.11n HT40	Temperature :	22~24°C
Test Band :	High	Relative Humidity :	50~52%
Test Channel :	09	Test Engineer :	Kyle Jhuang

ANTENNA POLARITY : HORIZONTAL										
Frequency ( MHz )	Level ( dBμV/m )	Over Limit ( dB )	Limit Line ( dBμV/m )	Read Level ( dBμV )	Antenna Factor ( dB )	Cable Loss ( dB )	Preamp Factor ( dB )	Ant Pos ( cm )	Table Pos ( deg )	Remark
2387.22	60.3	-13.7	74	57.32	32.29	6.22	35.53	123	185	Peak
2390	46.16	-7.84	54	43.15	32.29	6.22	35.5	123	185	Average
2485.48	72.2	-1.8	74	68.71	32.47	6.45	35.43	123	185	Peak
2487.79	50.68	-3.32	54	47.16	32.5	6.45	35.43	123	185	Average

ANTENNA POLARITY : VERTICAL										
Frequency ( MHz )	Level ( dBμV/m )	Over Limit ( dB )	Limit Line ( dBμV/m )	Read Level ( dBμV )	Antenna Factor ( dB )	Cable Loss ( dB )	Preamp Factor ( dB )	Ant Pos ( cm )	Table Pos ( deg )	Remark
2319.9	57.13	-16.87	74	54.36	32.16	6.18	35.57	146	48	Peak
2387.85	45.13	-8.87	54	42.15	32.29	6.22	35.53	146	48	Average
2484.94	63.06	-10.94	74	59.57	32.47	6.45	35.43	146	48	Peak
2493.31	46.27	-7.73	54	42.73	32.5	6.45	35.41	146	48	Average



3.5.7 Test Result of Radiated Spurious Emission (30MHz ~ 10<sup>th</sup> Harmonic)

Note: Pre-scanned all test modes and only choose the worst case mode recorded in the test report for radiated spurious emission below 1GHz.

<b>Test Mode :</b>	802.11b	<b>Temperature :</b>	22~24°C
<b>Test Channel :</b>	01	<b>Relative Humidity :</b>	50~52%
<b>Test Engineer :</b>	Kyle Jhuang	<b>Polarization :</b>	Horizontal
<b>Remark :</b>	1. 2412 MHz is fundamental signal which can be ignored. 2. Average measurement was not performed if peak level went lower than the average limit.		

Frequency ( MHz )	Level ( dBμV/m )	Over Limit ( dB )	Limit Line ( dBμV/m )	Read Level ( dBμV )	Antenna Factor ( dB )	Cable Loss ( dB )	Preamp Factor ( dB )	Ant Pos ( cm )	Table Pos ( deg )	Remark
150.69	13.24	-30.26	43.5	33.59	9.96	1.44	31.75	-	-	Peak
197.13	20.63	-22.87	43.5	41.93	8.82	1.63	31.75	-	-	Peak
230.07	25.38	-20.62	46	45.55	9.8	1.77	31.74	-	-	Peak
640.2	28.39	-17.61	46	38.66	18.85	2.92	32.04	-	-	Peak
689.9	31.46	-14.54	46	41.63	18.82	3.03	32.02	-	-	Peak
747.3	32.19	-13.81	46	41.1	19.94	3.14	31.99	100	19	Peak
2412	112.46	-	-	109.35	32.33	6.28	35.5	100	188	Average
2412	118.41	-	-	115.3	32.33	6.28	35.5	100	188	Peak
4824	38.73	-35.27	74	54.73	34.9	8.04	58.94	100	0	Peak



<b>Test Mode :</b>	802.11b	<b>Temperature :</b>	22~24°C
<b>Test Channel :</b>	01	<b>Relative Humidity :</b>	50~52%
<b>Test Engineer :</b>	Kyle Jhuang	<b>Polarization :</b>	Vertical
<b>Remark :</b>	1. 2414 MHz is fundamental signal which can be ignored. 2. Average measurement was not performed if peak level went lower than the average limit.		

Frequency ( MHz )	Level ( dBμV/m )	Over Limit ( dB )	Limit Line ( dBμV/m )	Read Level (dBμV)	Antenna Factor ( dB )	Cable Loss ( dB )	Preamp Factor ( dB )	Ant Pos ( cm )	Table Pos ( deg )	Remark
55.92	21.53	-18.47	40	46.84	5.59	0.88	31.78	-	-	Peak
74.55	19.17	-20.83	40	43.52	6.41	1.01	31.77	-	-	Peak
230.07	27.92	-18.08	46	47.76	10.13	1.77	31.74	-	-	Peak
500.2	21.82	-24.18	46	34.05	17.11	2.59	31.93	-	-	Peak
590.5	25.78	-20.22	46	36.27	18.75	2.81	32.05	-	-	Peak
689.9	28.88	-17.12	46	39.01	18.86	3.03	32.02	100	71	Peak
2414	104.64	-	-	101.53	32.33	6.28	35.5	152	54	Average
2414	110.57	-	-	107.46	32.33	6.28	35.5	152	54	Peak
4824	38.24	-35.76	74	54.24	34.9	8.04	58.94	100	0	Peak



<b>Test Mode :</b>	802.11b	<b>Temperature :</b>	22~24°C
<b>Test Channel :</b>	06	<b>Relative Humidity :</b>	50~52%
<b>Test Engineer :</b>	Kyle Jhuang	<b>Polarization :</b>	Horizontal
<b>Remark :</b>	1. 2436 MHz is fundamental signal which can be ignored. 2. Average measurement was not performed if peak level went lower than the average limit.		

Frequency ( MHz )	Level ( dBμV/m )	Over Limit ( dB )	Limit Line ( dBμV/m )	Read Level ( dBμV )	Antenna Factor ( dB )	Cable Loss ( dB )	Preamp Factor ( dB )	Ant Pos ( cm )	Table Pos ( deg )	Remark
2436	110.7	-	-	107.48	32.36	6.34	35.48	100	193	Average
2436	116.74	-	-	113.52	32.36	6.34	35.48	100	193	Peak
4875	39.96	-34.04	74	55.79	34.93	8.11	58.87	100	0	Peak
7311	39.93	-34.07	74	51.28	36.64	10.47	58.46	100	0	Peak

<b>Test Mode :</b>	802.11b	<b>Temperature :</b>	22~24°C
<b>Test Channel :</b>	06	<b>Relative Humidity :</b>	50~52%
<b>Test Engineer :</b>	Kyle Jhuang	<b>Polarization :</b>	Vertical
<b>Remark :</b>	1. 2438 MHz is fundamental signal which can be ignored. 2. Average measurement was not performed if peak level went lower than the average limit.		

Frequency ( MHz )	Level ( dBμV/m )	Over Limit ( dB )	Limit Line ( dBμV/m )	Read Level ( dBμV )	Antenna Factor ( dB )	Cable Loss ( dB )	Preamp Factor ( dB )	Ant Pos ( cm )	Table Pos ( deg )	Remark
2438	104.37	-	-	101.11	32.4	6.34	35.48	150	52	Average
2438	110.08	-	-	106.82	32.4	6.34	35.48	150	52	Peak
4875	40.05	-33.95	74	55.88	34.93	8.11	58.87	100	0	Peak
7311	40.91	-33.09	74	52.26	36.64	10.47	58.46	100	0	Peak



<b>Test Mode :</b>	802.11b	<b>Temperature :</b>	22~24°C
<b>Test Channel :</b>	11	<b>Relative Humidity :</b>	50~52%
<b>Test Engineer :</b>	Kyle Jhuang	<b>Polarization :</b>	Horizontal
<b>Remark :</b>	1. 2462 MHz is fundamental signal which can be ignored. 2. Average measurement was not performed if peak level went lower than the average limit.		

Frequency ( MHz )	Level ( dBμV/m )	Over Limit ( dB )	Limit Line ( dBμV/m )	Read Level ( dBμV )	Antenna Factor ( dB )	Cable Loss ( dB )	Preamp Factor ( dB )	Ant Pos ( cm )	Table Pos ( deg )	Remark
2462	110.21	-	-	106.85	32.43	6.39	35.46	123	184	Average
2462	116.5	-	-	113.14	32.43	6.39	35.46	123	184	Peak
4923	41.85	-32.15	74	57.51	34.96	8.18	58.8	100	0	Peak
7386	42.12	-31.88	74	53.66	36.62	10.45	58.61	100	0	Peak

<b>Test Mode :</b>	802.11b	<b>Temperature :</b>	22~24°C
<b>Test Channel :</b>	11	<b>Relative Humidity :</b>	50~52%
<b>Test Engineer :</b>	Kyle Jhuang	<b>Polarization :</b>	Vertical
<b>Remark :</b>	1. 2464 MHz is fundamental signal which can be ignored. 2. Average measurement was not performed if peak level went lower than the average limit.		

Frequency ( MHz )	Level ( dBμV/m )	Over Limit ( dB )	Limit Line ( dBμV/m )	Read Level ( dBμV )	Antenna Factor ( dB )	Cable Loss ( dB )	Preamp Factor ( dB )	Ant Pos ( cm )	Table Pos ( deg )	Remark
2464	101.08	-	-	97.72	32.43	6.39	35.46	149	49	Average
2464	107.23	-	-	103.87	32.43	6.39	35.46	149	49	Peak
4923	40.14	-33.86	74	55.8	34.96	8.18	58.8	100	0	Peak
7386	41.33	-32.67	74	52.87	36.62	10.45	58.61	100	0	Peak



<b>Test Mode :</b>	802.11g	<b>Temperature :</b>	22~24°C
<b>Test Channel :</b>	01	<b>Relative Humidity :</b>	50~52%
<b>Test Engineer :</b>	Kyle Jhuang	<b>Polarization :</b>	Horizontal
<b>Remark :</b>	1. 2414 MHz is fundamental signal which can be ignored. 2. Average measurement was not performed if peak level went lower than the average limit.		

Frequency ( MHz )	Level ( dBμV/m )	Over Limit ( dB )	Limit Line ( dBμV/m )	Read Level (dBμV)	Antenna Factor ( dB )	Cable Loss ( dB )	Preamp Factor ( dB )	Ant Pos ( cm )	Table Pos ( deg )	Remark
153.12	12.98	-30.52	43.5	33.43	9.85	1.45	31.75	-	-	Peak
197.67	20.31	-23.19	43.5	41.61	8.82	1.63	31.75	-	-	Peak
230.07	25.31	-20.69	46	45.48	9.8	1.77	31.74	-	-	Peak
689.9	31.53	-14.47	46	41.7	18.82	3.03	32.02	100	47	Peak
750.1	31.1	-14.9	46	39.98	19.96	3.15	31.99	-	-	Peak
806.1	30.09	-15.91	46	38.59	20.15	3.27	31.92	-	-	Peak
2414	103.05	-	-	99.94	32.33	6.28	35.5	100	187	Average
2414	113.79	-	-	110.68	32.33	6.28	35.5	100	187	Peak
4824	39.28	-34.72	74	55.28	34.9	8.04	58.94	100	0	Peak



<b>Test Mode :</b>	802.11g	<b>Temperature :</b>	22~24°C
<b>Test Channel :</b>	01	<b>Relative Humidity :</b>	50~52%
<b>Test Engineer :</b>	Kyle Jhuang	<b>Polarization :</b>	Vertical
<b>Remark :</b>	1. 2414 MHz is fundamental signal which can be ignored. 2. Average measurement was not performed if peak level went lower than the average limit.		

Frequency ( MHz )	Level ( dBμV/m )	Over Limit ( dB )	Limit Line ( dBμV/m )	Read Level ( dBμV )	Antenna Factor ( dB )	Cable Loss ( dB )	Preamp Factor ( dB )	Ant Pos ( cm )	Table Pos ( deg )	Remark
55.92	21.03	-18.97	40	46.34	5.59	0.88	31.78	-	-	Peak
145.83	16.24	-27.26	43.5	35.15	11.42	1.42	31.75	-	-	Peak
230.07	28.35	-17.65	46	48.19	10.13	1.77	31.74	100	148	Peak
500.2	20.99	-25.01	46	33.22	17.11	2.59	31.93	-	-	Peak
689.9	27.63	-18.37	46	37.76	18.86	3.03	32.02	-	-	Peak
786.5	25.03	-20.97	46	33.84	19.92	3.23	31.96	-	-	Peak
2414	95.02	-	-	91.91	32.33	6.28	35.5	180	49	Average
2414	105.79	-	-	102.68	32.33	6.28	35.5	180	49	Peak
4824	38.51	-35.49	74	54.51	34.9	8.04	58.94	100	0	Peak





<b>Test Mode :</b>	802.11g	<b>Temperature :</b>	22~24°C
<b>Test Channel :</b>	06	<b>Relative Humidity :</b>	50~52%
<b>Test Engineer :</b>	Kyle Jhuang	<b>Polarization :</b>	Horizontal
<b>Remark :</b>	1. 2438 MHz is fundamental signal which can be ignored. 2. Average measurement was not performed if peak level went lower than the average limit.		

Frequency ( MHz )	Level ( dBμV/m )	Over Limit ( dB )	Limit Line ( dBμV/m )	Read Level (dBμV)	Antenna Factor ( dB )	Cable Loss ( dB )	Preamp Factor ( dB )	Ant Pos ( cm )	Table Pos ( deg )	Remark
2438	102.28	-	-	99.02	32.4	6.34	35.48	122	183	Average
2438	112.99	-	-	109.73	32.4	6.34	35.48	122	183	Peak
4875	39.68	-34.32	74	55.51	34.93	8.11	58.87	100	0	Peak
7311	41.91	-32.09	74	53.26	36.64	10.47	58.46	100	0	Peak

<b>Test Mode :</b>	802.11g	<b>Temperature :</b>	22~24°C
<b>Test Channel :</b>	06	<b>Relative Humidity :</b>	50~52%
<b>Test Engineer :</b>	Kyle Jhuang	<b>Polarization :</b>	Vertical
<b>Remark :</b>	1. 2436 MHz is fundamental signal which can be ignored. 2. Average measurement was not performed if peak level went lower than the average limit.		

Frequency ( MHz )	Level ( dBμV/m )	Over Limit ( dB )	Limit Line ( dBμV/m )	Read Level (dBμV)	Antenna Factor ( dB )	Cable Loss ( dB )	Preamp Factor ( dB )	Ant Pos ( cm )	Table Pos ( deg )	Remark
2436	94.28	-	-	91.06	32.36	6.34	35.48	174	49	Average
2436	104.99	-	-	101.77	32.36	6.34	35.48	174	49	Peak
4875	39.7	-34.3	74	55.53	34.93	8.11	58.87	100	0	Peak
7311	40.35	-33.65	74	51.7	36.64	10.47	58.46	100	0	Peak



<b>Test Mode :</b>	802.11g	<b>Temperature :</b>	22~24°C
<b>Test Channel :</b>	11	<b>Relative Humidity :</b>	50~52%
<b>Test Engineer :</b>	Kyle Jhuang	<b>Polarization :</b>	Horizontal
<b>Remark :</b>	1. 2464 MHz is fundamental signal which can be ignored. 2. Average measurement was not performed if peak level went lower than the average limit.		

Frequency ( MHz )	Level ( dBμV/m )	Over Limit ( dB )	Limit Line ( dBμV/m )	Read Level ( dBμV )	Antenna Factor ( dB )	Cable Loss ( dB )	Preamp Factor ( dB )	Ant Pos ( cm )	Table Pos ( deg )	Remark
2464	101.46	-	-	98.1	32.43	6.39	35.46	121	187	Average
2464	112.51	-	-	109.15	32.43	6.39	35.46	121	187	Peak
4923	39.76	-34.24	74	55.42	34.96	8.18	58.8	100	0	Peak
7386	40.89	-33.11	74	52.43	36.62	10.45	58.61	100	0	Peak

<b>Test Mode :</b>	802.11g	<b>Temperature :</b>	22~24°C
<b>Test Channel :</b>	11	<b>Relative Humidity :</b>	50~52%
<b>Test Engineer :</b>	Kyle Jhuang	<b>Polarization :</b>	Vertical
<b>Remark :</b>	1. 2460 MHz is fundamental signal which can be ignored. 2. Average measurement was not performed if peak level went lower than the average limit.		

Frequency ( MHz )	Level ( dBμV/m )	Over Limit ( dB )	Limit Line ( dBμV/m )	Read Level ( dBμV )	Antenna Factor ( dB )	Cable Loss ( dB )	Preamp Factor ( dB )	Ant Pos ( cm )	Table Pos ( deg )	Remark
2460	92.31	-	-	88.95	32.43	6.39	35.46	146	48	Average
2460	103.36	-	-	100	32.43	6.39	35.46	146	48	Peak
4923	39.52	-34.48	74	55.18	34.96	8.18	58.8	100	0	Peak
7386	40.9	-33.1	74	52.44	36.62	10.45	58.61	100	0	Peak



<b>Test Mode :</b>	2.4GHz 802.11n HT20	<b>Temperature :</b>	22~24°C
<b>Test Channel :</b>	01	<b>Relative Humidity :</b>	50~52%
<b>Test Engineer :</b>	Kyle Jhuang	<b>Polarization :</b>	Horizontal
<b>Remark :</b>	1. 2414 MHz is fundamental signal which can be ignored. 2. Average measurement was not performed if peak level went lower than the average limit.		

Frequency ( MHz )	Level ( dBμV/m )	Over Limit ( dB )	Limit Line ( dBμV/m )	Read Level ( dBμV )	Antenna Factor ( dB )	Cable Loss ( dB )	Preamp Factor ( dB )	Ant Pos ( cm )	Table Pos ( deg )	Remark
2414	100.97	-	-	97.86	32.33	6.28	35.5	100	186	Average
2414	111.85	-	-	108.74	32.33	6.28	35.5	100	186	Peak
4824	39.18	-34.82	74	55.18	34.9	8.04	58.94	100	0	Peak

<b>Test Mode :</b>	2.4GHz 802.11n HT20	<b>Temperature :</b>	22~24°C
<b>Test Channel :</b>	01	<b>Relative Humidity :</b>	50~52%
<b>Test Engineer :</b>	Kyle Jhuang	<b>Polarization :</b>	Vertical
<b>Remark :</b>	1. 2410 MHz is fundamental signal which can be ignored. 2. Average measurement was not performed if peak level went lower than the average limit.		

Frequency ( MHz )	Level ( dBμV/m )	Over Limit ( dB )	Limit Line ( dBμV/m )	Read Level ( dBμV )	Antenna Factor ( dB )	Cable Loss ( dB )	Preamp Factor ( dB )	Ant Pos ( cm )	Table Pos ( deg )	Remark
2410	93.16	-	-	90.05	32.33	6.28	35.5	152	50	Average
2410	103.6	-	-	100.49	32.33	6.28	35.5	152	50	Peak
4824	38.41	-35.59	74	54.41	34.9	8.04	58.94	100	0	Peak



<b>Test Mode :</b>	2.4GHz 802.11n HT20	<b>Temperature :</b>	22~24°C
<b>Test Channel :</b>	06	<b>Relative Humidity :</b>	50~52%
<b>Test Engineer :</b>	Kyle Jhuang	<b>Polarization :</b>	Horizontal
<b>Remark :</b>	1. 2436 MHz is fundamental signal which can be ignored. 2. Average measurement was not performed if peak level went lower than the average limit.		

Frequency ( MHz )	Level ( dBμV/m )	Over Limit ( dB )	Limit Line ( dBμV/m )	Read Level ( dBμV )	Antenna Factor ( dB )	Cable Loss ( dB )	Preamp Factor ( dB )	Ant Pos ( cm )	Table Pos ( deg )	Remark
2436	100.08	-	-	96.86	32.36	6.34	35.48	100	188	Average
2436	110.54	-	-	107.32	32.36	6.34	35.48	100	188	Peak
4875	38.8	-35.2	74	54.63	34.93	8.11	58.87	100	0	Peak
7311	39.92	-34.08	74	51.27	36.64	10.47	58.46	100	0	Peak

<b>Test Mode :</b>	2.4GHz 802.11n HT20	<b>Temperature :</b>	22~24°C
<b>Test Channel :</b>	06	<b>Relative Humidity :</b>	50~52%
<b>Test Engineer :</b>	Kyle Jhuang	<b>Polarization :</b>	Vertical
<b>Remark :</b>	1. 2438 MHz is fundamental signal which can be ignored. 2. Average measurement was not performed if peak level went lower than the average limit.		

Frequency ( MHz )	Level ( dBμV/m )	Over Limit ( dB )	Limit Line ( dBμV/m )	Read Level ( dBμV )	Antenna Factor ( dB )	Cable Loss ( dB )	Preamp Factor ( dB )	Ant Pos ( cm )	Table Pos ( deg )	Remark
2438	91.76	-	-	88.5	32.4	6.34	35.48	174	57	Average
2438	102.24	-	-	98.98	32.4	6.34	35.48	174	57	Peak
4875	39.24	-34.76	74	55.07	34.93	8.11	58.87	100	0	Peak
7311	40.68	-33.32	74	52.03	36.64	10.47	58.46	100	0	Peak



<b>Test Mode :</b>	2.4GHz 802.11n HT20	<b>Temperature :</b>	22~24°C
<b>Test Channel :</b>	11	<b>Relative Humidity :</b>	50~52%
<b>Test Engineer :</b>	Kyle Jhuang	<b>Polarization :</b>	Horizontal
<b>Remark :</b>	1. 2460 MHz is fundamental signal which can be ignored. 2. Average measurement was not performed if peak level went lower than the average limit.		

Frequency ( MHz )	Level ( dBμV/m )	Over Limit ( dB )	Limit Line ( dBμV/m )	Read Level ( dBμV )	Antenna Factor ( dB )	Cable Loss ( dB )	Preamp Factor ( dB )	Ant Pos ( cm )	Table Pos ( deg )	Remark
156.63	12.7	-30.8	43.5	33.32	9.66	1.47	31.75	-	-	Peak
197.94	19.6	-23.9	43.5	40.9	8.82	1.63	31.75	-	-	Peak
230.07	25.38	-20.62	46	45.55	9.8	1.77	31.74	-	-	Peak
356	20.24	-25.76	46	35.3	14.54	2.18	31.78	-	-	Peak
689.9	31.92	-14.08	46	42.09	18.82	3.03	32.02	100	59	Peak
746.6	30.74	-15.26	46	39.65	19.94	3.14	31.99	-	-	Peak
2460	99.32	-	-	95.96	32.43	6.39	35.46	123	183	Average
2460	109.93	-	-	106.57	32.43	6.39	35.46	123	183	Peak
4923	39.39	-34.61	74	55.05	34.96	8.18	58.8	100	0	Peak
7386	41.16	-32.84	74	52.7	36.62	10.45	58.61	100	0	Peak



<b>Test Mode :</b>	2.4GHz 802.11n HT20	<b>Temperature :</b>	22~24°C
<b>Test Channel :</b>	11	<b>Relative Humidity :</b>	50~52%
<b>Test Engineer :</b>	Kyle Jhuang	<b>Polarization :</b>	Vertical
<b>Remark :</b>	1. 2464 MHz is fundamental signal which can be ignored. 2. Average measurement was not performed if peak level went lower than the average limit.		

Frequency ( MHz )	Level ( dBμV/m )	Over Limit ( dB )	Limit Line ( dBμV/m )	Read Level ( dBμV )	Antenna Factor ( dB )	Cable Loss ( dB )	Preamp Factor ( dB )	Ant Pos ( cm )	Table Pos ( deg )	Remark
56.19	21.13	-18.87	40	46.44	5.59	0.88	31.78	-	-	Peak
147.99	17.09	-26.41	43.5	36.08	11.33	1.43	31.75	-	-	Peak
230.07	27.99	-18.01	46	47.83	10.13	1.77	31.74	100	155	Peak
499.5	21.92	-24.08	46	34.18	17.08	2.59	31.93	-	-	Peak
635.3	26.07	-19.93	46	36.7	18.51	2.91	32.05	-	-	Peak
689.9	27.19	-18.81	46	37.32	18.86	3.03	32.02	-	-	Peak
2464	90.4	-	-	87.04	32.43	6.39	35.46	146	50	Average
2464	101.46	-	-	98.1	32.43	6.39	35.46	146	50	Peak
4923	39.34	-34.66	74	55	34.96	8.18	58.8	100	0	Peak
7386	39.97	-34.03	74	51.51	36.62	10.45	58.61	100	0	Peak



<b>Test Mode :</b>	2.4GHz 802.11n HT40	<b>Temperature :</b>	22~24°C
<b>Test Channel :</b>	03	<b>Relative Humidity :</b>	50~52%
<b>Test Engineer :</b>	Kyle Jhuang	<b>Polarization :</b>	Horizontal
<b>Remark :</b>	1. 2420 MHz is fundamental signal which can be ignored. 2. Average measurement was not performed if peak level went lower than the average limit.		

Frequency ( MHz )	Level ( dBμV/m )	Over Limit ( dB )	Limit Line ( dBμV/m )	Read Level ( dBμV )	Antenna Factor ( dB )	Cable Loss ( dB )	Preamp Factor ( dB )	Ant Pos ( cm )	Table Pos ( deg )	Remark
2420	96.64	-	-	93.48	32.36	6.28	35.48	100	186	Average
2420	106.65	-	-	103.49	32.36	6.28	35.48	100	186	Peak
4845	39.02	-34.98	74	54.96	34.91	8.07	58.92	100	0	Peak
7266	40.66	-33.34	74	51.94	36.64	10.48	58.4	100	0	Peak

<b>Test Mode :</b>	2.4GHz 802.11n HT40	<b>Temperature :</b>	22~24°C
<b>Test Channel :</b>	03	<b>Relative Humidity :</b>	50~52%
<b>Test Engineer :</b>	Kyle Jhuang	<b>Polarization :</b>	Vertical
<b>Remark :</b>	1. 2424 MHz is fundamental signal which can be ignored. 2. Average measurement was not performed if peak level went lower than the average limit.		

Frequency ( MHz )	Level ( dBμV/m )	Over Limit ( dB )	Limit Line ( dBμV/m )	Read Level ( dBμV )	Antenna Factor ( dB )	Cable Loss ( dB )	Preamp Factor ( dB )	Ant Pos ( cm )	Table Pos ( deg )	Remark
2424	88.51	-	-	85.35	32.36	6.28	35.48	180	52	Average
2424	98.8	-	-	95.64	32.36	6.28	35.48	180	52	Peak
4845	37.95	-36.05	74	53.89	34.91	8.07	58.92	100	0	Peak
7266	40.08	-33.92	74	51.36	36.64	10.48	58.4	100	0	Peak



<b>Test Mode :</b>	2.4GHz 802.11n HT40	<b>Temperature :</b>	22~24°C
<b>Test Channel :</b>	06	<b>Relative Humidity :</b>	50~52%
<b>Test Engineer :</b>	Kyle Jhuang	<b>Polarization :</b>	Horizontal
<b>Remark :</b>	1. 2435 MHz is fundamental signal which can be ignored. 2. Average measurement was not performed if peak level went lower than the average limit.		

Frequency ( MHz )	Level ( dBμV/m )	Over Limit ( dB )	Limit Line ( dBμV/m )	Read Level (dBμV)	Antenna Factor ( dB )	Cable Loss ( dB )	Preamp Factor ( dB )	Ant Pos ( cm )	Table Pos ( deg )	Remark
2435	98.09	-	-	94.87	32.36	6.34	35.48	100	187	Average
2435	109.09	-	-	105.87	32.36	6.34	35.48	100	187	Peak
4875	38.06	-35.94	74	53.89	34.93	8.11	58.87	100	0	Peak
7311	40.79	-33.21	74	52.14	36.64	10.47	58.46	100	0	Peak

<b>Test Mode :</b>	2.4GHz 802.11n HT40	<b>Temperature :</b>	22~24°C
<b>Test Channel :</b>	06	<b>Relative Humidity :</b>	50~52%
<b>Test Engineer :</b>	Kyle Jhuang	<b>Polarization :</b>	Vertical
<b>Remark :</b>	1. 2438 MHz is fundamental signal which can be ignored. 2. Average measurement was not performed if peak level went lower than the average limit.		

Frequency ( MHz )	Level ( dBμV/m )	Over Limit ( dB )	Limit Line ( dBμV/m )	Read Level (dBμV)	Antenna Factor ( dB )	Cable Loss ( dB )	Preamp Factor ( dB )	Ant Pos ( cm )	Table Pos ( deg )	Remark
2438	89.56	-	-	86.3	32.4	6.34	35.48	143	47	Average
2438	99.6	-	-	96.34	32.4	6.34	35.48	143	47	Peak
4875	38.63	-35.37	74	54.46	34.93	8.11	58.87	100	0	Peak
7311	40.25	-33.75	74	51.6	36.64	10.47	58.46	100	0	Peak





<b>Test Mode :</b>	2.4GHz 802.11n HT40	<b>Temperature :</b>	22~24°C
<b>Test Channel :</b>	09	<b>Relative Humidity :</b>	50~52%
<b>Test Engineer :</b>	Kyle Jhuang	<b>Polarization :</b>	Horizontal
<b>Remark :</b>	1. 2454 MHz is fundamental signal which can be ignored. 2. Average measurement was not performed if peak level went lower than the average limit.		

Frequency ( MHz )	Level ( dBμV/m )	Over Limit ( dB )	Limit Line ( dBμV/m )	Read Level ( dBμV )	Antenna Factor ( dB )	Cable Loss ( dB )	Preamp Factor ( dB )	Ant Pos ( cm )	Table Pos ( deg )	Remark
2454	97.68	-	-	94.32	32.43	6.39	35.46	123	185	Average
2454	108.46	-	-	105.1	32.43	6.39	35.46	123	185	Peak
4905	39.95	-34.05	74	55.64	34.95	8.18	58.82	100	0	Peak
7356	40.3	-33.7	74	51.76	36.63	10.46	58.55	100	0	Peak

<b>Test Mode :</b>	2.4GHz 802.11n HT40	<b>Temperature :</b>	22~24°C
<b>Test Channel :</b>	09	<b>Relative Humidity :</b>	50~52%
<b>Test Engineer :</b>	Kyle Jhuang	<b>Polarization :</b>	Vertical
<b>Remark :</b>	1. 2450 MHz is fundamental signal which can be ignored. 2. Average measurement was not performed if peak level went lower than the average limit.		

Frequency ( MHz )	Level ( dBμV/m )	Over Limit ( dB )	Limit Line ( dBμV/m )	Read Level ( dBμV )	Antenna Factor ( dB )	Cable Loss ( dB )	Preamp Factor ( dB )	Ant Pos ( cm )	Table Pos ( deg )	Remark
2450	88.65	-	-	85.37	32.4	6.34	35.46	146	48	Average
2450	98.98	-	-	95.7	32.4	6.34	35.46	146	48	Peak
4905	38.7	-35.3	74	54.39	34.95	8.18	58.82	100	0	Peak
7356	39.97	-34.03	74	51.43	36.63	10.46	58.55	100	0	Peak



<b>Test Mode :</b>	802.11a	<b>Temperature :</b>	22~24°C
<b>Test Channel :</b>	149	<b>Relative Humidity :</b>	50~52%
<b>Test Engineer :</b>	Kyle Jhuang	<b>Polarization :</b>	Horizontal
<b>Remark :</b>	1. 5744 MHz is fundamental signal which can be ignored. 2. Average measurement was not performed if peak level went lower than the average limit.		

Frequency ( MHz )	Level ( dBμV/m )	Over Limit ( dB )	Limit Line ( dBμV/m )	Read Level (dBμV)	Antenna Factor ( dB )	Cable Loss ( dB )	Preamp Factor ( dB )	Ant Pos ( cm )	Table Pos ( deg )	Remark
5744	103.23	-	-	93.01	35.74	9.1	34.62	102	303	Average
5744	113.16	-	-	102.94	35.74	9.1	34.62	102	303	Peak
11488	47.56	-26.44	74	53.26	38.69	12.92	57.31	100	0	Peak

<b>Test Mode :</b>	802.11a	<b>Temperature :</b>	22~24°C
<b>Test Channel :</b>	149	<b>Relative Humidity :</b>	50~52%
<b>Test Engineer :</b>	Kyle Jhuang	<b>Polarization :</b>	Vertical
<b>Remark :</b>	5743 MHz is fundamental signal which can be ignored.		

Frequency ( MHz )	Level ( dBμV/m )	Over Limit ( dB )	Limit Line ( dBμV/m )	Read Level (dBμV)	Antenna Factor ( dB )	Cable Loss ( dB )	Preamp Factor ( dB )	Ant Pos ( cm )	Table Pos ( deg )	Remark
5743	103.71	-	-	93.49	35.74	9.1	34.62	127	297	Average
5743	113.85	-	-	103.63	35.74	9.1	34.62	127	297	Peak
11492	43.02	-10.98	54	48.72	38.69	12.92	57.31	119	328	Average
11492	53.77	-20.23	74	59.47	38.69	12.92	57.31	119	328	Peak



<b>Test Mode :</b>	802.11a	<b>Temperature :</b>	22~24°C
<b>Test Channel :</b>	157	<b>Relative Humidity :</b>	50~52%
<b>Test Engineer :</b>	Kyle Jhuang	<b>Polarization :</b>	Horizontal
<b>Remark :</b>	1. 5787 MHz is fundamental signal which can be ignored. 2. Average measurement was not performed if peak level went lower than the average limit.		

Frequency ( MHz )	Level ( dBμV/m )	Over Limit ( dB )	Limit Line ( dBμV/m )	Read Level ( dBμV )	Antenna Factor ( dB )	Cable Loss ( dB )	Preamp Factor ( dB )	Ant Pos ( cm )	Table Pos ( deg )	Remark
5787	102.4	-	-	92.1	35.81	9.13	34.64	112	309	Average
5787	112.51	-	-	102.21	35.81	9.13	34.64	112	309	Peak
11572	50.46	-23.54	74	55.98	38.78	13	57.3	100	0	Peak

<b>Test Mode :</b>	802.11a	<b>Temperature :</b>	22~24°C
<b>Test Channel :</b>	157	<b>Relative Humidity :</b>	50~52%
<b>Test Engineer :</b>	Kyle Jhuang	<b>Polarization :</b>	Vertical
<b>Remark :</b>	5786 MHz is fundamental signal which can be ignored.		

Frequency ( MHz )	Level ( dBμV/m )	Over Limit ( dB )	Limit Line ( dBμV/m )	Read Level ( dBμV )	Antenna Factor ( dB )	Cable Loss ( dB )	Preamp Factor ( dB )	Ant Pos ( cm )	Table Pos ( deg )	Remark
5786	103.57	-	-	93.27	35.81	9.13	34.64	126	292	Average
5786	113.62	-	-	103.32	35.81	9.13	34.64	126	292	Peak
11572	43.7	-10.3	54	49.22	38.78	13	57.3	124	329	Average
11572	53.57	-20.43	74	59.09	38.78	13	57.3	124	329	Peak



<b>Test Mode :</b>	802.11a	<b>Temperature :</b>	22~24°C
<b>Test Channel :</b>	165	<b>Relative Humidity :</b>	50~52%
<b>Test Engineer :</b>	Kyle Jhuang	<b>Polarization :</b>	Horizontal
<b>Remark :</b>	1. 5824 MHz is fundamental signal which can be ignored. 2. Average measurement was not performed if peak level went lower than the average limit.		

Frequency ( MHz )	Level ( dBμV/m )	Over Limit ( dB )	Limit Line ( dBμV/m )	Read Level ( dBμV )	Antenna Factor ( dB )	Cable Loss ( dB )	Preamp Factor ( dB )	Ant Pos ( cm )	Table Pos ( deg )	Remark
150.42	12.88	-30.62	43.5	33.23	9.96	1.44	31.75	-	-	Peak
197.94	19.41	-24.09	43.5	40.71	8.82	1.63	31.75	-	-	Peak
230.07	25.57	-20.43	46	45.74	9.8	1.77	31.74	-	-	Peak
344.8	20.46	-25.54	46	35.89	14.19	2.14	31.76	-	-	Peak
689.9	32.48	-13.52	46	42.65	18.82	3.03	32.02	100	11	Peak
748.7	30.45	-15.55	46	39.29	20	3.15	31.99	-	-	Peak
5824	103.28	-	-	92.82	35.86	9.25	34.65	101	312	Average
5824	113.17	-	-	102.71	35.86	9.25	34.65	101	312	Peak
11652	48.58	-25.42	74	53.9	38.89	13.09	57.3	100	0	Peak



<b>Test Mode :</b>	802.11a	<b>Temperature :</b>	22~24°C
<b>Test Channel :</b>	165	<b>Relative Humidity :</b>	50~52%
<b>Test Engineer :</b>	Kyle Jhuang	<b>Polarization :</b>	Vertical
<b>Remark :</b>	5823 MHz is fundamental signal which can be ignored.		

Frequency ( MHz )	Level ( dBμV/m )	Over Limit ( dB )	Limit Line ( dBμV/m )	Read Level (dBμV)	Antenna Factor ( dB )	Cable Loss ( dB )	Preamp Factor ( dB )	Ant Pos ( cm )	Table Pos ( deg )	Remark
56.19	20.95	-19.05	40	46.26	5.59	0.88	31.78	-	-	Peak
150.69	16.12	-27.38	43.5	35.19	11.24	1.44	31.75	-	-	Peak
230.07	27.7	-18.3	46	47.54	10.13	1.77	31.74	100	121	Peak
600.3	25.76	-20.24	46	36.08	18.91	2.83	32.06	-	-	Peak
689.9	27.61	-18.39	46	37.74	18.86	3.03	32.02	-	-	Peak
811	25.3	-20.7	46	33.54	20.38	3.28	31.9	-	-	Peak
5823	103.67	-	-	93.21	35.86	9.25	34.65	124	296	Average
5823	113.96	-	-	103.5	35.86	9.25	34.65	124	296	Peak
11652	44.05	-9.95	54	49.37	38.89	13.09	57.3	100	325	Average
11652	53.52	-20.48	74	58.84	38.89	13.09	57.3	100	325	Peak



<b>Test Mode :</b>	5GHz 802.11n HT20	<b>Temperature :</b>	22~24°C
<b>Test Channel :</b>	149	<b>Relative Humidity :</b>	50~52%
<b>Test Engineer :</b>	Kyle Jhuang	<b>Polarization :</b>	Horizontal
<b>Remark :</b>	1. 5747 MHz is fundamental signal which can be ignored. 2. Average measurement was not performed if peak level went lower than the average limit.		

Frequency ( MHz )	Level ( dBμV/m )	Over Limit ( dB )	Limit Line ( dBμV/m )	Read Level (dBμV)	Antenna Factor ( dB )	Cable Loss ( dB )	Preamp Factor ( dB )	Ant Pos ( cm )	Table Pos ( deg )	Remark
5747	99.91	-	-	89.69	35.74	9.1	34.62	113	309	Average
5747	110.35	-	-	100.13	35.74	9.1	34.62	113	309	Peak
11490	45.85	-28.15	74	51.55	38.69	12.92	57.31	100	0	Peak

<b>Test Mode :</b>	5GHz 802.11n HT20	<b>Temperature :</b>	22~24°C
<b>Test Channel :</b>	149	<b>Relative Humidity :</b>	50~52%
<b>Test Engineer :</b>	Kyle Jhuang	<b>Polarization :</b>	Vertical
<b>Remark :</b>	1. 5743 MHz is fundamental signal which can be ignored. 2. Average measurement was not performed if peak level went lower than the average limit.		

Frequency ( MHz )	Level ( dBμV/m )	Over Limit ( dB )	Limit Line ( dBμV/m )	Read Level (dBμV)	Antenna Factor ( dB )	Cable Loss ( dB )	Preamp Factor ( dB )	Ant Pos ( cm )	Table Pos ( deg )	Remark
5743	100.32	-	-	90.1	35.74	9.1	34.62	115	291	Average
5743	112.22	-	-	102	35.74	9.1	34.62	115	291	Peak
11492	47.93	-26.07	74	53.63	38.69	12.92	57.31	100	0	Peak



<b>Test Mode :</b>	5GHz 802.11n HT20	<b>Temperature :</b>	22~24°C
<b>Test Channel :</b>	157	<b>Relative Humidity :</b>	50~52%
<b>Test Engineer :</b>	Kyle Jhuang	<b>Polarization :</b>	Horizontal
<b>Remark :</b>	1. 5783 MHz is fundamental signal which can be ignored. 2. Average measurement was not performed if peak level went lower than the average limit.		

Frequency ( MHz )	Level ( dBμV/m )	Over Limit ( dB )	Limit Line ( dBμV/m )	Read Level ( dBμV )	Antenna Factor ( dB )	Cable Loss ( dB )	Preamp Factor ( dB )	Ant Pos ( cm )	Table Pos ( deg )	Remark
71.04	12.59	-27.41	40	37.78	5.59	0.99	31.77	-	-	Peak
197.94	19.64	-23.86	43.5	40.94	8.82	1.63	31.75	-	-	Peak
230.07	25.47	-20.53	46	45.64	9.8	1.77	31.74	-	-	Peak
344.8	20.1	-25.9	46	35.53	14.19	2.14	31.76	-	-	Peak
689.9	31.93	-14.07	46	42.1	18.82	3.03	32.02	100	52	Peak
750.1	31.89	-14.11	46	40.77	19.96	3.15	31.99	-	-	Peak
5783	100.67	-	-	90.39	35.79	9.13	34.64	102	310	Average
5783	110.91	-	-	100.63	35.79	9.13	34.64	102	310	Peak
11571	45.61	-28.39	74	51.13	38.78	13	57.3	100	0	Peak



<b>Test Mode :</b>	5GHz 802.11n HT20	<b>Temperature :</b>	22~24°C
<b>Test Channel :</b>	157	<b>Relative Humidity :</b>	50~52%
<b>Test Engineer :</b>	Kyle Jhuang	<b>Polarization :</b>	Vertical
<b>Remark :</b>	1. 5783 MHz is fundamental signal which can be ignored. 2. Average measurement was not performed if peak level went lower than the average limit.		

Frequency ( MHz )	Level ( dBμV/m )	Over Limit ( dB )	Limit Line ( dBμV/m )	Read Level (dBμV)	Antenna Factor ( dB )	Cable Loss ( dB )	Preamp Factor ( dB )	Ant Pos ( cm )	Table Pos ( deg )	Remark
55.92	21.06	-18.94	40	46.37	5.59	0.88	31.78	-	-	Peak
150.69	16.89	-26.61	43.5	35.96	11.24	1.44	31.75	-	-	Peak
230.07	27.9	-18.1	46	47.74	10.13	1.77	31.74	100	133	Peak
500.2	22.09	-23.91	46	34.32	17.11	2.59	31.93	-	-	Peak
601	25.9	-20.1	46	36.28	18.85	2.83	32.06	-	-	Peak
689.9	26.7	-19.3	46	36.83	18.86	3.03	32.02	-	-	Peak
5783	100.49	-	-	90.21	35.79	9.13	34.64	126	295	Average
5783	110.93	-	-	100.65	35.79	9.13	34.64	126	295	Peak
11572	49.69	-24.31	74	55.21	38.78	13	57.3	100	0	Peak





<b>Test Mode :</b>	5GHz 802.11n HT20	<b>Temperature :</b>	22~24°C
<b>Test Channel :</b>	165	<b>Relative Humidity :</b>	50~52%
<b>Test Engineer :</b>	Kyle Jhuang	<b>Polarization :</b>	Horizontal
<b>Remark :</b>	1. 5823 MHz is fundamental signal which can be ignored. 2. Average measurement was not performed if peak level went lower than the average limit.		

Frequency ( MHz )	Level ( dBμV/m )	Over Limit ( dB )	Limit Line ( dBμV/m )	Read Level ( dBμV )	Antenna Factor ( dB )	Cable Loss ( dB )	Preamp Factor ( dB )	Ant Pos ( cm )	Table Pos ( deg )	Remark
5823	100.48	-	-	90.02	35.86	9.25	34.65	101	309	Average
5823	110.95	-	-	100.49	35.86	9.25	34.65	101	309	Peak
11652	46.57	-27.43	74	51.89	38.89	13.09	57.3	100	0	Peak

<b>Test Mode :</b>	5GHz 802.11n HT20	<b>Temperature :</b>	22~24°C
<b>Test Channel :</b>	165	<b>Relative Humidity :</b>	50~52%
<b>Test Engineer :</b>	Kyle Jhuang	<b>Polarization :</b>	Vertical
<b>Remark :</b>	1. 5823 MHz is fundamental signal which can be ignored. 2. Average measurement was not performed if peak level went lower than the average limit.		

Frequency ( MHz )	Level ( dBμV/m )	Over Limit ( dB )	Limit Line ( dBμV/m )	Read Level ( dBμV )	Antenna Factor ( dB )	Cable Loss ( dB )	Preamp Factor ( dB )	Ant Pos ( cm )	Table Pos ( deg )	Remark
5823	100.44	-	-	89.98	35.86	9.25	34.65	124	296	Average
5823	111.33	-	-	100.87	35.86	9.25	34.65	124	296	Peak
11648	49.42	-24.58	74	54.76	38.87	13.09	57.3	100	0	Peak



<b>Test Mode :</b>	5GHz 802.11n HT40	<b>Temperature :</b>	22~24°C
<b>Test Channel :</b>	151	<b>Relative Humidity :</b>	50~52%
<b>Test Engineer :</b>	Kyle Jhuang	<b>Polarization :</b>	Horizontal
<b>Remark :</b>	1. 5757 MHz is fundamental signal which can be ignored. 2. Average measurement was not performed if peak level went lower than the average limit.		

Frequency ( MHz )	Level ( dBμV/m )	Over Limit ( dB )	Limit Line ( dBμV/m )	Read Level (dBμV)	Antenna Factor ( dB )	Cable Loss ( dB )	Preamp Factor ( dB )	Ant Pos ( cm )	Table Pos ( deg )	Remark
5757	97.2	-	-	86.97	35.76	9.1	34.63	113	307	Average
5757	108.52	-	-	98.29	35.76	9.1	34.63	113	307	Peak
11511	43.27	-30.73	74	48.92	38.7	12.95	57.3	100	0	Peak

<b>Test Mode :</b>	5GHz 802.11n HT40	<b>Temperature :</b>	22~24°C
<b>Test Channel :</b>	151	<b>Relative Humidity :</b>	50~52%
<b>Test Engineer :</b>	Kyle Jhuang	<b>Polarization :</b>	Vertical
<b>Remark :</b>	1. 5757 MHz is fundamental signal which can be ignored. 2. Average measurement was not performed if peak level went lower than the average limit.		

Frequency ( MHz )	Level ( dBμV/m )	Over Limit ( dB )	Limit Line ( dBμV/m )	Read Level (dBμV)	Antenna Factor ( dB )	Cable Loss ( dB )	Preamp Factor ( dB )	Ant Pos ( cm )	Table Pos ( deg )	Remark
5757	97.67	-	-	87.44	35.76	9.1	34.63	114	292	Average
5757	108.07	-	-	97.84	35.76	9.1	34.63	114	292	Peak
11511	47.26	-26.74	74	52.91	38.7	12.95	57.3	100	0	Peak



<b>Test Mode :</b>	5GHz 802.11n HT40	<b>Temperature :</b>	22~24°C
<b>Test Channel :</b>	159	<b>Relative Humidity :</b>	50~52%
<b>Test Engineer :</b>	Kyle Jhuang	<b>Polarization :</b>	Horizontal
<b>Remark :</b>	1. 5793 MHz is fundamental signal which can be ignored. 2. Average measurement was not performed if peak level went lower than the average limit.		

Frequency ( MHz )	Level ( dBμV/m )	Over Limit ( dB )	Limit Line ( dBμV/m )	Read Level (dBμV)	Antenna Factor ( dB )	Cable Loss ( dB )	Preamp Factor ( dB )	Ant Pos ( cm )	Table Pos ( deg )	Remark
5793	97.72	-	-	87.39	35.81	9.16	34.64	102	308	Average
5793	107.62	-	-	97.29	35.81	9.16	34.64	102	308	Peak
11589	43.42	-30.58	74	48.9	38.8	13.02	57.3	100	0	Peak

<b>Test Mode :</b>	5GHz 802.11n HT40	<b>Temperature :</b>	22~24°C
<b>Test Channel :</b>	159	<b>Relative Humidity :</b>	50~52%
<b>Test Engineer :</b>	Kyle Jhuang	<b>Polarization :</b>	Vertical
<b>Remark :</b>	1. 5793 MHz is fundamental signal which can be ignored. 2. Average measurement was not performed if peak level went lower than the average limit.		

Frequency ( MHz )	Level ( dBμV/m )	Over Limit ( dB )	Limit Line ( dBμV/m )	Read Level (dBμV)	Antenna Factor ( dB )	Cable Loss ( dB )	Preamp Factor ( dB )	Ant Pos ( cm )	Table Pos ( deg )	Remark
5793	97.07	-	-	86.74	35.81	9.16	34.64	125	292	Average
5793	106.83	-	-	96.5	35.81	9.16	34.64	125	292	Peak
11592	48.15	-25.85	74	53.63	38.8	13.02	57.3	100	0	Peak



<b>Test Mode :</b>	5GHz 802.11n VHT80	<b>Temperature :</b>	22~24°C
<b>Test Channel :</b>	155	<b>Relative Humidity :</b>	50~52%
<b>Test Engineer :</b>	Kyle Jhuang	<b>Polarization :</b>	Horizontal
<b>Remark :</b>	1. 5777 MHz is fundamental signal which can be ignored. 2. Average measurement was not performed if peak level went lower than the average limit.		

Frequency ( MHz )	Level ( dBμV/m )	Over Limit ( dB )	Limit Line ( dBμV/m )	Read Level (dBμV)	Antenna Factor ( dB )	Cable Loss ( dB )	Preamp Factor ( dB )	Ant Pos ( cm )	Table Pos ( deg )	Remark
197.67	20.62	-22.88	43.5	41.92	8.82	1.63	31.75	-	-	Peak
230.07	25.45	-20.55	46	45.62	9.8	1.77	31.74	-	-	Peak
272.19	12.94	-33.06	46	30.28	12.47	1.92	31.73	-	-	Peak
689.9	32.17	-13.83	46	42.34	18.82	3.03	32.02	100	76	Peak
750.1	30.97	-15.03	46	39.85	19.96	3.15	31.99	-	-	Peak
812.4	29.14	-16.86	46	37.48	20.27	3.29	31.9	-	-	Peak
5777	95.08	-	-	84.79	35.79	9.13	34.63	102	311	Average
5777	104.82	-	-	94.53	35.79	9.13	34.63	102	311	Peak
11550	43.47	-30.53	74	49.01	38.76	13	57.3	100	0	Peak



<b>Test Mode :</b>	5GHz 802.11n VHT80	<b>Temperature :</b>	22~24°C
<b>Test Channel :</b>	155	<b>Relative Humidity :</b>	50~52%
<b>Test Engineer :</b>	Kyle Jhuang	<b>Polarization :</b>	Vertical
<b>Remark :</b>	1. 5773 MHz is fundamental signal which can be ignored. 2. Average measurement was not performed if peak level went lower than the average limit.		

Frequency ( MHz )	Level ( dBμV/m )	Over Limit ( dB )	Limit Line ( dBμV/m )	Read Level ( dBμV )	Antenna Factor ( dB )	Cable Loss ( dB )	Preamp Factor ( dB )	Ant Pos ( cm )	Table Pos ( deg )	Remark
55.92	21.08	-18.92	40	46.39	5.59	0.88	31.78	-	-	Peak
74.82	19.14	-20.86	40	43.49	6.41	1.01	31.77	-	-	Peak
230.07	28.43	-17.57	46	48.27	10.13	1.77	31.74	100	162	Peak
600.3	26.29	-19.71	46	36.61	18.91	2.83	32.06	-	-	Peak
689.9	27.67	-18.33	46	37.8	18.86	3.03	32.02	-	-	Peak
786.5	24.88	-21.12	46	33.69	19.92	3.23	31.96	-	-	Peak
5773	95.04	-	-	84.75	35.79	9.13	34.63	115	297	Average
5773	104.94	-	-	94.65	35.79	9.13	34.63	115	297	Peak
11550	45.42	-28.58	74	50.96	38.76	13	57.3	100	0	Peak

### 3.7 AC Conducted Emission Measurement

#### 3.7.1 Limit of AC Conducted Emission

For equipment that is designed to be connected to the public utility (AC) power line, the radio frequency voltage that is conducted back onto the AC power line on any frequency or frequencies within the band 150 kHz to 30 MHz shall not exceed the limits in the following table.

Frequency of Emission (MHz)	Conducted Limit (dB $\mu$ V)	
	Quasi-Peak	Average
0.15-0.5	66 to 56*	56 to 46*
0.5-5	56	46
5-30	60	50

\*Decreases with the logarithm of the frequency.

#### 3.7.2 Measuring Instruments

The measuring equipment is listed in the section 4 of this test report.

#### 3.7.3 Test Procedures

1. The EUT was placed 0.4 meter from the conducting wall of the shielding room, and it was kept at least 80 centimeters from any other grounded conducting surface.
2. Connect EUT to the power mains through a line impedance stabilization network (LISN).
3. All the support units are connecting to the other LISN.
4. The LISN provides 50 ohm coupling impedance for the measuring instrument.
5. The FCC states that a 50 ohm, 50 microhenry LISN should be used.
6. Both sides of AC line were checked for maximum conducted interference.
7. The frequency range from 150 kHz to 30 MHz was searched.
8. Set the test-receiver system to Peak Detect Function and specified bandwidth with Maximum Hold Mode.

### 3.7.4 Test Setup

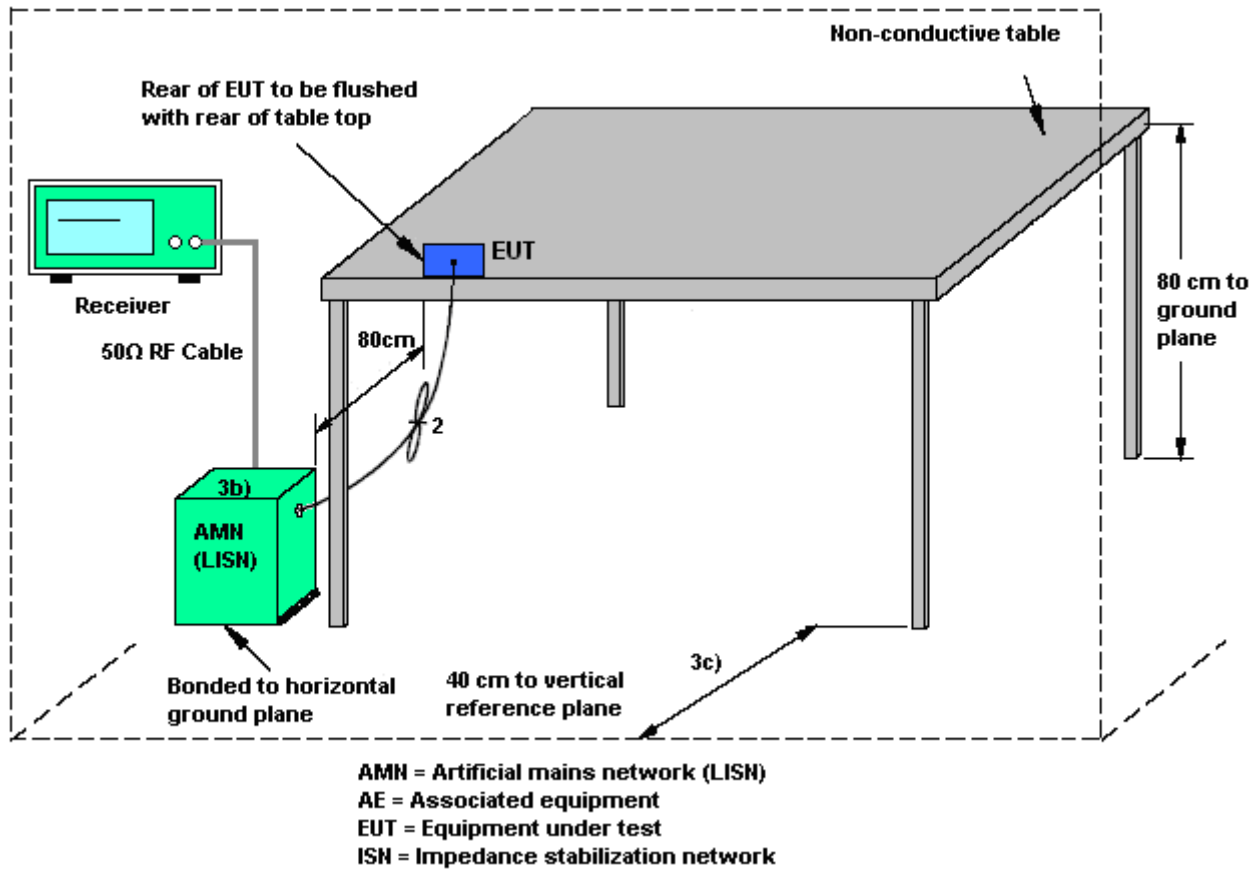

3.7.5 Test Result of AC Conducted Emission

Test Mode :	Mode 1	Temperature :	20~22°C
Test Engineer :	Cosmo Xu	Relative Humidity :	45~47%
Test Voltage :	120Vac / 60Hz	Phase :	Line
Function Type :	Bluetooth Link + WLAN (2.4GHz) Link + HDMI + Speaker + RJ-45 (Load) + Mouse + SD Card + MPEG4 + Adapter		

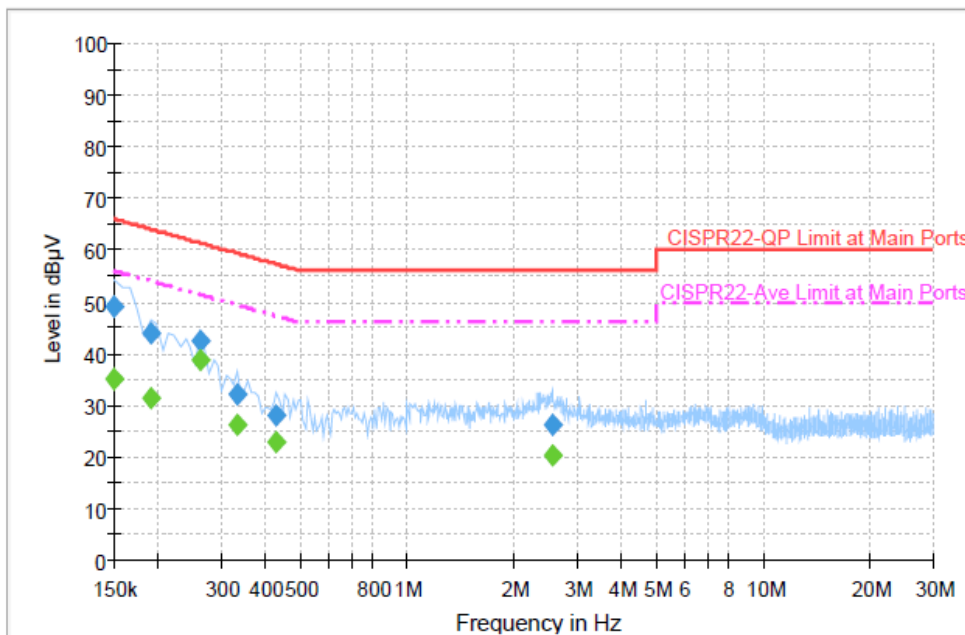

Final Result : Quasi-Peak

Frequency (MHz)	Quasi-Peak (dBµV)	Filter	Line	Corr. (dB)	Margin (dB)	Limit (dBµV)
0.150000	49.0	Off	L1	19.4	17.0	66.0
0.190000	44.1	Off	L1	19.4	19.9	64.0
0.262000	42.3	Off	L1	19.3	19.1	61.4
0.334000	32.0	Off	L1	19.4	27.4	59.4
0.430000	28.1	Off	L1	19.4	29.2	57.3
2.550000	26.1	Off	L1	19.6	29.9	56.0

Final Result : Average

Frequency (MHz)	Average (dBµV)	Filter	Line	Corr. (dB)	Margin (dB)	Limit (dBµV)
0.150000	35.1	Off	L1	19.4	20.9	56.0
0.190000	31.3	Off	L1	19.4	22.7	54.0
0.262000	38.7	Off	L1	19.3	12.7	51.4
0.334000	26.3	Off	L1	19.4	23.1	49.4
0.430000	23.1	Off	L1	19.4	24.2	47.3
2.550000	20.2	Off	L1	19.6	25.8	46.0



Test Mode :	Mode 1	Temperature :	20~22°C
Test Engineer :	Cosmo Xu	Relative Humidity :	45~47%
Test Voltage :	120Vac / 60Hz	Phase :	Neutral
Function Type :	Bluetooth Link + WLAN (2.4GHz) Link + HDMI + Speaker + RJ-45 (Load) + Mouse + SD Card + MPEG4 + Adapter		

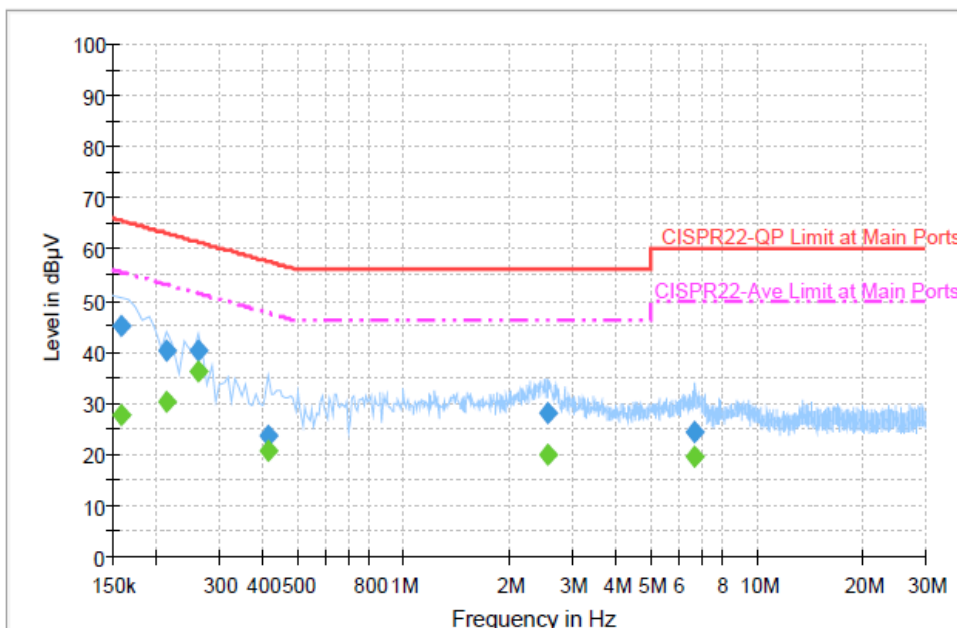

**Final Result : Quasi-Peak**

Frequency (MHz)	Quasi-Peak (dBµV)	Filter	Line	Corr. (dB)	Margin (dB)	Limit (dBµV)
0.158000	45.2	Off	N	19.3	20.4	65.6
0.214000	40.2	Off	N	19.4	22.8	63.0
0.262000	40.1	Off	N	19.4	21.3	61.4
0.414000	23.6	Off	N	19.4	34.0	57.6
2.566000	28.0	Off	N	19.6	28.0	56.0
6.702000	24.3	Off	N	19.6	35.7	60.0

**Final Result : Average**

Frequency (MHz)	Average (dBµV)	Filter	Line	Corr. (dB)	Margin (dB)	Limit (dBµV)
0.158000	27.8	Off	N	19.3	27.8	55.6
0.214000	30.4	Off	N	19.4	22.6	53.0
0.262000	36.3	Off	N	19.4	15.1	51.4
0.414000	20.7	Off	N	19.4	26.9	47.6
2.566000	20.0	Off	N	19.6	26.0	46.0
6.702000	19.5	Off	N	19.6	30.5	50.0



### **3.7.6 Antenna Requirements**

#### **3.7.7 Standard Applicable**

If directional gain of transmitting antennas is greater than 6dBi, the power shall be reduced by the same level in dB comparing to gain minus 6dBi. For the fixed point-to-point operation, the power shall be reduced by one dB for every 3 dB that the directional gain of the antenna exceeds 6 dBi. The use of a permanently attached antenna or of an antenna that uses a unique coupling to the intentional radiator shall be considered sufficient to comply with the FCC rule.

#### **3.7.8 Antenna Anti-Replacement Construction**

An embedded-in antenna design is used.

#### **3.7.9 Antenna Gain**

The antenna peak gain of EUT is less than 6 dBi. Therefore, it is not necessary to reduce maximum peak output power limit.



## 4 List of Measuring Equipment

Instrument	Manufacturer	Model No.	Serial No.	Characteristics	Calibration Date	Test Date	Due Date	Remark
Spectrum Analyzer	Rohde & Schwarz	FSP40	100055	9kHz~40GHz	Jun. 07, 2013	Mar. 06, 2014 ~ Mar. 10, 2014	Jun. 06, 2014	Conducted (TH02-HY)
Power Meter	Anritsu	ML2495A	1036004	300MHz~40GHz	Aug. 17, 2013	Mar. 06, 2014 ~ Mar. 10, 2014	Aug. 16, 2014	Conducted (TH02-HY)
Power Sensor	Anritsu	MA2411B	1027253	300MHz~40GHz	Aug. 17, 2013	Mar. 06, 2014 ~ Mar. 10, 2014	Aug. 16, 2014	Conducted (TH02-HY)
EMI Test Receiver	Rohde & Schwarz	ESU26	100472	20Hz – 26.5GHz	Jan. 15, 2014	Mar. 07, 2014~ Mar. 08, 2014	Jan. 14, 2015	Radiation (03CH08-HY)
Bilog Antenna	Teseq GmbH	CBL6112D	35379	30MHz~2GHz	Oct. 10, 2013	Mar. 07, 2014~ Mar. 08, 2014	Oct. 09, 2014	Radiation (03CH08-HY)
Horn Antenna	ESCO	3117	000143261	1GHz~18GHz	Jan. 16, 2014	Mar. 07, 2014~ Mar. 08, 2014	Jan. 15, 2015	Radiation (03CH08-HY)
SHF-EHF Horn Antenna	SCHWARZBECK	BBHA 9170	BBHA9170251	15GHz~40GHz	Oct. 03, 2013	Mar. 07, 2014~ Mar. 08, 2014	Oct. 02, 2014	Radiation (03CH08-HY)
Amplifier	SONOMA	310N	187231	9kHz~1GHz	May 15, 2013	Mar. 07, 2014~ Mar. 08, 2014	May 14, 2014	Radiation (03CH08-HY)
Preamplifier	MITEQ	AMF-7D-0010 1800-30-10P	1590074	1GHz~18GHz	Jul. 09, 2013	Mar. 07, 2014~ Mar. 08, 2014	Jul. 08, 2014	Radiation (03CH08-HY)
Pre Amplifier	Agilent	8449B	3008A02665	1GHz~26.5GHz	Sep. 04, 2013	Mar. 07, 2014~ Mar. 08, 2014	Sep. 03, 2014	Radiation (03CH08-HY)
Turn Table	Chaintek	Chaintek 3000	N/A	0~360 Degree	N/A	Mar. 07, 2014~ Mar. 08, 2014	N/A	Radiation (03CH08-HY)
Antenna Mast	MF	MFA520BS	N/A	1m~4m	N/A	Mar. 07, 2014~ Mar. 08, 2014	N/A	Radiation (03CH08-HY)
Loop Antenna	Rohde & Schwarz	HFH2-Z2	860004/0001	9 kHz~30 MHz	Jul. 03, 2012	Mar. 07, 2014~ Mar. 08, 2014	Jul. 03, 2014	Radiation (03CH08-HY)
EMI Test Receiver	Rohde & Schwarz	ESCS 30	100356	9kHz ~ 2.75GHz	Nov. 15, 2013	Mar. 06, 2014	Nov. 14, 2014	Conduction (CO05-HY)
LISN (for auxiliary equipment)	Rohde & Schwarz	ENV216	100081	9kHz ~ 30MHz	Dec. 12, 2013	Mar. 06, 2014	Dec. 11, 2014	Conduction (CO05-HY)
LISN	Rohde & Schwarz	ENV216	100080	9kHz ~ 30MHz	Dec. 04, 2013	Mar. 06, 2014	Dec. 03, 2014	Conduction (CO05-HY)
AC Power Source	ChainTek	APC-1000W	N/A	N/A	N/A	Mar. 06, 2014	N/A	Conduction (CO05-HY)



## 5 Uncertainty of Evaluation

### Uncertainty of Conducted Emission Measurement (150kHz ~ 30MHz)

Measuring Uncertainty for a Level of Confidence of 95% ( $U = 2Uc(y)$ )	2.26
---	------

### Uncertainty of Radiated Emission Measurement (30 MHz ~ 1000 MHz)

Measuring Uncertainty for a Level of Confidence of 95% ( $U = 2Uc(y)$ )	4.30
---	------

