

TEST REPORT

Report No.: 18050043HKG-002

Systech Electronics Ltd.

Application For Certification
(Original Grant)

FCC ID: 2ABQ3-SPC002

Transceiver

This report contains Bluetooth portion only

Prepared and Checked by:

Approved by:

Signed On File
Wong Cheuk Ho, Herbert
Lead Engineer

Wong Kwok Yeung, Kenneth
Senior Lead Engineer
Date: June 05, 2018

Intertek's standard Terms and Conditions can be obtained at our website <http://www.intertek.com/terms/>.

The test report only allows to be revised within the retention period unless further standard or the requirement was noticed.

This report is for the exclusive use of Intertek's Client and is provided pursuant to the agreement between Intertek and its Client. Intertek's responsibility and liability are limited to the terms and conditions of the agreement. Intertek assumes no liability to any party, other than to the Client in accordance with the agreement, for any loss, expense or damage occasioned by the use of this report. Only the Client is authorized to permit copying or distribution of this report and then only in its entirety. Any use of the Intertek name or one of its marks for the sale or advertisement of the tested material, product or service must first be approved in writing by Intertek. The observations and test results in this report are relevant only to the sample tested. This report by itself does not imply that the material, product, or service is or has ever been under an Intertek certification program.

© 2017 Intertek

TEST REPORT**GENERAL INFORMATION**

Grantee:	Systech Electronics Ltd.
Grantee Address:	Unit 802, 8/F., Sunbeam Centre, 27 Shing Yip Street, Kwun Tong, Kowloon, Hong Kong.
Contact Person:	Patrick Lee
Tel:	(852) 2770 8248
Fax:	(852) 2389 0979
e-mail:	patrick@systechele.com
Manufacturer:	Victory Telecom (Huizhou) Ltd.
Manufacturer Address:	Building A, No. 18 Shuiyuan Industrial District, Ruhu Town, Huizhou City 516021, Guangdong Province, P.R. China.
Brand Name:	Wifi Body Camera
Model:	SPC002
Type of EUT:	Transceiver
Description of EUT:	Wifi Body Camera
Serial Number:	N/A
FCC ID:	2ABQ3-SPC002
Date of Sample Submitted:	May 02, 2018
Date of Test:	May 02, 2018 to June 05, 2018
Report No.:	18050043HKG-002
Report Date:	June 05, 2018
Environmental Conditions:	Temperature: +10 to 40°C Humidity: 10 to 90%

TEST REPORT

SUMMARY OF TEST RESULT

Test Specification	Reference	Results
Transmitter Power Line Conducted Emissions	15.207	Pass
Radiated Emission Radiated Emission on the Bandedge	15.249, 15.209	Pass
Radiated Emission in Restricted Bands	15.205	Pass

The equipment under test is found to be complying with the following standards:
FCC Part 15, October 1, 2016 Edition

Note: 1. The EUT uses a permanently attached antenna which, in accordance to section 15.203, is considered sufficient to comply with the provisions of this section.
2. Pursuant to FCC part 15 Section 15.215(c), the 20 dB bandwidth of the emission was contained within the frequency band designated (mentioned as above) which the EUT operated. The effects, if any, from frequency sweeping, frequency hopping, other modulation techniques and frequency stability over excepted variations in temperature and supply voltage were considered.

TEST REPORT

TABLE OF CONTENTS

1.0 GENERAL DESCRIPTION 5

 1.1 Product Description5

 1.2 Related Submittal(s) Grants6

 1.3 Test Methodology.....6

 1.4 Test Facility6

2.0 SYSTEM TEST CONFIGURATION..... 7

 2.1 Justification.....7

 2.2 EUT Exercising Software.....7

 2.3 Special Accessories7

 2.4 Measurement Uncertainty.....8

 2.5 Support Equipment List and Description.....8

3.0 EMISSION RESULTS..... 9

 3.1 Field Strength Calculation9

 3.2 Radiated Emission Configuration Photograph.....10

 3.3 Radiated Emission Data10

 3.4 Conducted Emission Configuration Photograph10

 3.5 Conducted Emission Data10

4.0 EQUIPMENT PHOTOGRAPHS 16

5.0 PRODUCT LABELLING..... 16

6.0 TECHNICAL SPECIFICATIONS 16

7.0 INSTRUCTION MANUAL..... 16

8.0 MISCELLANEOUS INFORMATION 17

 8.1 Radiated Emission on the Bandedge.....17

 8.2 Discussion of Pulse Desensitization.....20

 8.3 Calculation of Average Factor20

 8.4 Emissions Test Procedures.....21

9.0 CONFIDENTIALITY REQUEST 25

10.0 EQUIPMENT LIST..... 25

TEST REPORT

1.0 GENERAL DESCRIPTION

1.1 Product Description

The SPC002 is a Wifi Body Camera.

The Equipment Under Test (EUT) contains a 2.4GHz RF module with WiFi and Bluetooth 4.0 BLE features. After pairing the EUT with a smartphone, the EUT camera function can be controlled via the smartphone Apps. A docking station is for charging the EUT and PC data transfer. When the apps is running, the EUT cannot support data transfer between PC. The USB port of docking station becomes charging purpose only. When the EUT disconnect with the smartphone Apps, the USB port of docking station can perform data transfer between PC. The EUT is powered by internal 3.8V rechargeable battery and/or 5VDC supplied from charging connector of the docking station. The EUT cannot support Bluetooth 3.0 feature.

For WiFi portion:

For 802.11b mode, it operates at frequency range of 2412MHz to 2462MHz with 11 channels. It transmits via Direct-sequence spread spectrum (DSSS) modulation. Maximum bit rate can be up to 11Mbps.

For 802.11g mode, it operates at frequency range of 2412MHz to 2462MHz with 11 channels. It transmits via Orthogonal Frequency Division Multiplexing (OFDM) modulation. Maximum bit rate can be up to 54Mbps.

For 802.11n (HT20 with 20MHz bandwidth) mode, it operates at frequency range of 2412MHz to 2462MHz with 11 channels. It transmits via Orthogonal Frequency Division Multiplexing (OFDM) modulation. Maximum bit rate can support up to 65Mbps.

The EUT cannot support 802.11n (HT40 40MHz bandwidth) as declared by the applicant.

For Bluetooth portion:

For Bluetooth 4.0 BLE mode, it occupies a frequency range from 2402MHz to 2480MHz (40 channels with channel spacing of 2MHz). It transmits via GFSK modulation.

The antenna(s) used in the EUT is integral, and the test sample is a prototype.

The circuit description is saved with filename: descri.pdf.

TEST REPORT

1.2 Related Submittal(s) Grants

This is a single application for certification of a transceiver (Bluetooth portion).

1.3 Test Methodology

Both AC mains line-conducted and radiated emission measurements were performed according to the procedures in ANSI C63.10 (2013). All radiated measurements were performed in an 3m Chamber. Preliminary scans were performed in the 3m Chamber only to determine worst case modes. All radiated tests were performed at an antenna to EUT distance of 3 meters, unless stated otherwise in the “**Justification Section**” of this Application.

1.4 Test Facility

The 3m Chamber and conducted measurement facility used to collect the radiated data is located at Workshop No. 3, G/F., World-Wide Industrial Centre, 43-47 Shan Mei Street, Fo Tan, Sha Tin, N.T., Hong Kong. This test facility and site measurement data have been placed on file with the FCC.

TEST REPORT

2.0 SYSTEM TEST CONFIGURATION

2.1 Justification

The system was configured for testing in a typical fashion (as a customer would normally use it), and in the confines as outlined in ANSI C63.10 (2013).

The EUT was powered by internal 3.8VDC rechargeable battery and/or 5VDC supplied by docking station. Both powering method were tested and only worse-case data is presented in this report (powered by docking station, the docking station was connected to notebook via USB port)

For maximizing emissions, the EUT was rotated through 360°, the antenna height was varied from 1 meter to 4 meters above the ground plane, and the antenna polarization was changed. This step by step procedure for maximizing emissions led to the data reported in Exhibit 3.0.

The rear of unit shall be flushed with the rear of the table.

The equipment under test (EUT) was configured for testing in a typical fashion (as a customer would normally use it). The EUT was mounted to a plastic stand if necessary and placed on the wooden turntable, which enabled the engineer to maximize emissions through its placement in the three orthogonal axes.

All connecting cables of EUT and peripherals were manipulated to find the maximum emission.

All configuration mode and setting of data rate for Bluetooth 4.0 BLE mode had been considered, and worst case test data are shown on this test report.

For simultaneous transmission, both WiFi and Bluetooth portions are also switched on when taking radiated emission for determining worst-case spurious emission.

2.2 EUT Exercising Software

The EUT exercise program (if any) used during radiated testing was designed to exercise the various system components in a manner similar to a typical use.

2.3 Special Accessories

There are no special accessories necessary for compliance of this product.

TEST REPORT

2.4 Measurement Uncertainty

When determining of the test conclusion, the Measurement Uncertainty of test has been considered.

Uncertainty and Compliance - Unless the standard specifically states that measured values are to be extended by the measurement uncertainty in determining compliance, all compliance determinations are based on the actual measured value.

2.5 Support Equipment List and Description

1. HP Notebook Computer (Adaptor Model: HSTNN-CA15)
2. LAN cable of 2m long
(Provided by Intertek)
3. USB cable of 0.9m long
4. Docking Station
(Provided by Applicant)

TEST REPORT

3.0 EMISSION RESULTS

Data is included of the worst case configuration (the configuration which resulted in the highest emission levels). A sample calculation, configuration photographs and data tables of the emissions are included.

3.1 Field Strength Calculation

The field strength is calculated by adding the Antenna Factor and Cable Factor, and subtracting the Amplifier Gain (if any), Average Factor (optional) from the measured reading. The basic equation with a sample calculation is as follows:

$$FS = RA + AF + CF - AG - AV$$

where FS = Field Strength in dB μ V/m

RA = Receiver Amplitude (including preamplifier) in dB μ V

CF = Cable Attenuation Factor in dB

AF = Antenna Factor in dB

AG = Amplifier Gain in dB

AV = Average Factor in dB

In the following table(s), the reading shown on the data table reflects the preamplifier gain. An example for the calculations in the following table is as follows:

$$FS = RR + LF$$

where FS = Field Strength in dB μ V/m

RR = RA - AG - AV in dB μ V

LF = CF + AF in dB

Assume a receiver reading of 52.0 dB μ V is obtained. The antenna factor of 7.4 dB and cable factor of 1.6 dB are added. The amplifier gain of 29 dB and average factor of 5 dB are subtracted, giving a field strength of 32 dB μ V/m. This value in dB μ V/m was converted to its corresponding level in μ V/m.

$$RA = 52.0 \text{ dB}\mu\text{V/m}$$

$$AF = 7.4 \text{ dB}$$

$$CF = 1.6 \text{ dB}$$

$$AG = 29.0 \text{ dB}$$

$$AV = 5.0 \text{ dB}$$

$$FS = RR + LF$$

$$FS = 18 + 9 = 27 \text{ dB}\mu\text{V/m}$$

$$RR = 18.0 \text{ dB}\mu\text{V}$$

$$LF = 9.0 \text{ dB}$$

$$\text{Level in } \mu\text{V/m} = \text{Common Antilogarithm } [(27 \text{ dB}\mu\text{V/m})/20] = 22.4 \mu\text{V/m}$$

TEST REPORT

3.2 Radiated Emission Configuration Photograph

The worst case in radiated emission was found at 45.304 MHz

For electronic filing, the worst case radiated emission configuration photographs are saved with filename: radiated photos.pdf.

3.3 Radiated Emission Data

The data on the following page lists the significant emission frequencies, the limit and the margin of compliance. Numbers with a minus sign are below the limit.

Judgment: Passed by 1.1 dB

3.4 Conducted Emission Configuration Photograph

The worst case in line-conducted emission was found at 0.150 MHz

For electronic filing, the worst case line-conducted configuration photographs are saved with filename: conducted photo.pdf.

3.5 Conducted Emission Data

For electronic filing, the graph and data table of conducted emission is saved with filename: conducted.pdf.

Judgment: Pass by 9.2 dB

TEST REPORT

CONDUCTED EMISSION

Model: SPC002

Date of Test: June 05, 2018

Worst-Case Operating Mode: WiFi + Bluetooth + Charging

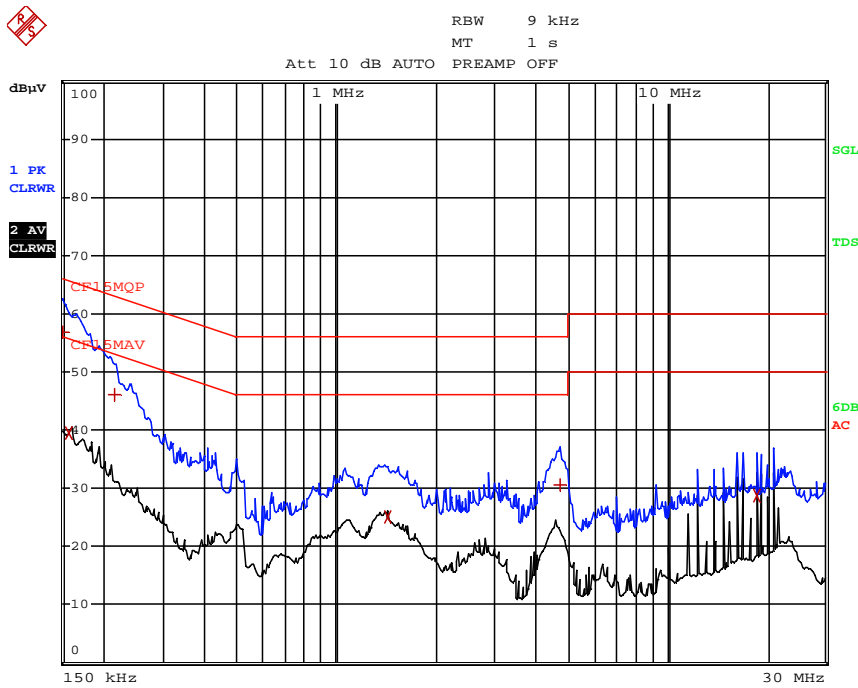

EDIT PEAK LIST (Final Measurement Results)				
TRACE	FREQUENCY	LEVEL dBµV	DELTA	LIMIT dB
Trace1:	CF15MQP			
Trace2:	CF15MAV			
Trace3:	---			
1	Quasi Peak 150 kHz	56.80	L1	-9.19
2	CISPR Average 159 kHz	39.42	N	-16.09
1	Quasi Peak 217.5 kHz	46.02	L1	-16.88
2	CISPR Average 1.428 MHz	25.11	N	-20.88
1	Quasi Peak 4.7625 MHz	30.44	L1	-25.55
2	CISPR Average 18.5415 MHz	28.72	L1	-21.27

Note: Measurement Uncertainty is ±4.2dB at a level of confidence of 95%.

TEST REPORT

RADIATED EMISSIONS

Model: SPC002

Date of Test: June 05, 2018

Worst-Case Operating Mode: Transmitting (Bluetooth 4.0 BLE)

Table 1
Pursuant to FCC Part 15 Section 15.249 Requirement

Lowest Channel

Polarization	Frequency (MHz)	Reading (dBµV)	Pre-Amp Gain (dB)	Antenna Factor (dB)	Net at 3m - Peak (dBµV/m)	Average Factor (dB)	Calculated at 3m (dBµV/m)	Average Limit at 3m (dBµV/m)	Margin (dB)
H	2402.000	95.8	33	29.4	92.2	0	92.2	94.0	-1.8
H	4804.000	44.0	33	34.9	45.9	0	45.9	54.0	-8.1
H	7206.000	42.9	33	37.9	47.8	0	47.8	54.0	-6.2
H	9608.000	41.9	33	40.4	49.3	0	49.3	54.0	-4.7
H	12010.000	44.7	33	40.5	52.2	0	52.2	54.0	-1.8
H	14412.000	45.4	33	40.0	52.4	0	52.4	54.0	-1.6

Polarization	Frequency (MHz)	Reading (dBµV)	Pre-Amp Gain (dB)	Antenna Factor (dB)	Net at 3m - Peak (dBµV/m)	Peak Limit at 3m (dBµV/m)	Margin (dB)
H	2402.000	95.8	33	29.4	92.2	114.0	-21.8
H	4804.000	44.0	33	34.9	45.9	74.0	-28.1
H	7206.000	42.9	33	37.9	47.8	74.0	-26.2
H	9608.000	41.9	33	40.4	49.3	74.0	-24.7
H	12010.000	44.7	33	40.5	52.2	74.0	-21.8
H	14412.000	45.4	33	40.0	52.4	74.0	-21.6

- NOTES:
1. Peak Detector Data unless otherwise stated.
 2. All measurements were made at 3 meters. Harmonic emissions not detected at the 3-meter distances were measured at 0.3-meter and an inverse proportional extrapolation was performed to compare the signal level to the 3-meter limit. No other harmonic emissions than those reported were detected at a test distance of 0.3-meter.
 3. Negative sign in the column shows value below limit.
 4. Horn antenna is used for the emission over 1000MHz.
 5. Emission (the row indicated by **bold italic**) within the restricted band meets the requirement of FCC Part 15 Section 15.205.
 6. Measurement Uncertainty is ±5.3dB at a level of confidence of 95%.

TEST REPORT

Model: SPC002
Date of Test: June 05, 2018
Worst-Case Operating Mode: Transmitting (Bluetooth 4.0 BLE)

Table 2
Pursuant to FCC Part 15 Section 15.249 Requirement

Middle Channel

Polarization	Frequency (MHz)	Reading (dBμV)	Pre-Amp Gain (dB)	Antenna Factor (dB)	Net at 3m - Peak (dBμV/m)	Average Factor (dB)	Calculated at 3m (dBμV/m)	Average Limit at 3m (dBμV/m)	Margin (dB)
H	2440.000	96.0	33	29.4	92.4	0	92.4	94.0	-1.6
H	4880.000	44.2	33	34.9	46.1	0	46.1	54.0	-7.9
H	7320.000	43.3	33	37.9	48.2	0	48.2	54.0	-5.8
H	9760.000	42.3	33	40.4	49.7	0	49.7	54.0	-4.3
H	12200.000	44.9	33	40.5	52.4	0	52.4	54.0	-1.6
H	14640.000	47.0	33	38.4	52.4	0	52.4	54.0	-1.6

Polarization	Frequency (MHz)	Reading (dBμV)	Pre-Amp Gain (dB)	Antenna Factor (dB)	Net at 3m - Peak (dBμV/m)	Peak Limit at 3m (dBμV/m)	Margin (dB)
H	2440.000	96.0	33	29.4	92.4	114.0	-21.6
H	4880.000	44.2	33	34.9	46.1	74.0	-27.9
H	7320.000	43.3	33	37.9	48.2	74.0	-25.8
H	9760.000	42.3	33	40.4	49.7	74.0	-24.3
H	12200.000	44.9	33	40.5	52.4	74.0	-21.6
H	14640.000	47.0	33	38.4	52.4	74.0	-21.6

- NOTES:
1. Peak Detector Data unless otherwise stated.
 2. All measurements were made at 3 meters. Harmonic emissions not detected at the 3-meter distances were measured at 0.3-meter and an inverse proportional extrapolation was performed to compare the signal level to the 3-meter limit. No other harmonic emissions than those reported were detected at a test distance of 0.3-meter.
 3. Negative sign in the column shows value below limit.
 4. Horn antenna is used for the emission over 1000MHz.
 5. Emission (the row indicated by **bold italic**) within the restricted band meets the requirement of FCC Part 15 Section 15.205.
 6. Measurement Uncertainty is ±5.3dB at a level of confidence of 95%.

TEST REPORT

Model: SPC002

Date of Test: June 05, 2018

Worst-Case Operating Mode: Transmitting (Bluetooth 4.0 BLE)

Table 3
Pursuant to FCC Part 15 Section 15.249 Requirement

Highest Channel

Polarization	Frequency (MHz)	Reading (dBµV)	Pre-Amp Gain (dB)	Antenna Factor (dB)	Net at 3m - Peak (dBµV/m)	Average Factor (dB)	Calculated at 3m (dBµV/m)	Average Limit at 3m (dBµV/m)	Margin (dB)
H	2480.000	96.1	33	29.4	92.5	0	92.5	94.0	-1.5
H	4960.000	44.1	33	34.9	46.0	0	46.0	54.0	-8.0
H	7440.000	43.2	33	37.9	48.1	0	48.1	54.0	-5.9
H	9920.000	42.2	33	40.4	49.6	0	49.6	54.0	-4.4
H	12400.000	44.8	33	40.5	52.3	0	52.3	54.0	-1.7
H	14880.000	47.0	33	38.4	52.4	0	52.4	54.0	-1.6

Polarization	Frequency (MHz)	Reading (dBµV)	Pre-Amp Gain (dB)	Antenna Factor (dB)	Net at 3m - Peak (dBµV/m)	Peak Limit at 3m (dBµV/m)	Margin (dB)
H	2480.000	96.1	33	29.4	92.5	114.0	-21.5
H	4960.000	44.1	33	34.9	46.0	74.0	-28.0
H	7440.000	43.2	33	37.9	48.1	74.0	-25.9
H	9920.000	42.2	33	40.4	49.6	74.0	-24.4
H	12400.000	44.8	33	40.5	52.3	74.0	-21.7
H	14880.000	47.0	33	38.4	52.4	74.0	-21.6

- NOTES:
1. Peak Detector Data unless otherwise stated.
 2. All measurements were made at 3 meters. Harmonic emissions not detected at the 3-meter distances were measured at 0.3-meter and an inverse proportional extrapolation was performed to compare the signal level to the 3-meter limit. No other harmonic emissions than those reported were detected at a test distance of 0.3-meter.
 3. Negative sign in the column shows value below limit.
 4. Horn antenna is used for the emission over 1000MHz.
 5. Emission (the row indicated by **bold italic**) within the restricted band meets the requirement of FCC Part 15 Section 15.205.
 6. Measurement Uncertainty is ±5.3dB at a level of confidence of 95%.

TEST REPORT

Model: SPC002

Date of Test: June 05, 2018

Worst-Case Operating Mode: WiFi + Bluetooth + Charging

Table 4
Pursuant to FCC Part 15 Section 15.209 Requirement

Polarization	Frequency (MHz)	Reading (dBμV)	Pre-amp (dB)	Antenna Factor (dB)	Net at 3m (dBμV/m)	Limit at 3m (dBμV/m)	Margin (dB)
V	31.240	41.8	16	10.0	35.8	40.0	-4.2
V	45.304	44.9	16	10.0	38.9	40.0	-1.1
V	75.698	45.8	16	6.0	35.8	40.0	-4.2
V	89.224	47.5	16	9.0	40.5	43.5	-3.0
V	131.688	35.2	16	14.0	33.2	43.5	-10.3
V	164.776	32.5	16	17.0	33.5	43.5	-10.0
V	200.774	33.2	16	16.0	33.2	43.5	-10.3
V	219.688	41.8	16	17.0	42.8	46.0	-3.2
V	238.604	29.4	16	19.0	32.4	46.0	-13.6
H	320.568	24.6	16	23.0	31.6	46.0	-14.4
H	545.555	20.5	16	28.0	32.5	46.0	-13.5
H	729.532	23.4	16	30.0	37.4	46.0	-8.6

- NOTES:
1. Quasi-Peak Detector Data unless otherwise stated.
 2. All measurements were made at 3 meters. Harmonic emissions not detected at the 3-meter distances were measured at 0.3-meter and an inverse proportional extrapolation was performed to compare the signal level to the 3-meter limit. No other harmonic emissions than those reported were detected at a test distance of 0.3-meter.
 3. Negative sign in the column shows value below limit.
 4. Horn antenna is used for the emission over 1000MHz.
 5. Emission (the row indicated by **bold italic**) within the restricted band meets the requirement of FCC Part 15 Section 15.205.
 6. Measurement Uncertainty is ±5.3dB at a level of confidence of 95%.

TEST REPORT

4.0 EQUIPMENT PHOTOGRAPHS

For electronic filing, the photographs are saved with filename: external photos.pdf and internal photos.pdf.

5.0 PRODUCT LABELLING

For electronics filing, the FCC ID label artwork and the label location are saved with filename: label.pdf.

6.0 TECHNICAL SPECIFICATIONS

For electronic filing, the block diagram and schematic of the tested EUT are saved with filename: block.pdf and circuit.pdf respectively.

7.0 INSTRUCTION MANUAL

For electronic filing, a preliminary copy of the Instruction Manual is saved with filename: manual.pdf.

This manual will be provided to the end-user with each unit sold/leased in the United States.

TEST REPORT

8.0 MISCELLANEOUS INFORMATION

The miscellaneous information includes details of the test procedure and measured bandwidth / calculation of factor such as pulse desensitization and averaging factor (calculation and timing diagram).

8.1 Radiated Emission on the Bandedge

From the following plots, they show that the fundamental emissions are confined in the specified band (2400MHz to 2483.5MHz). In case of the fundamental emissions are within two standard bandwidths from the bandedge, the delta measurement technique is used for determining bandedge compliance. Standard bandwidth is the bandwidth specified by ANSI C63.10 (2013) for frequency being measured.

Emissions radiated outside of the specified frequency bands, except harmonics, are attenuated by 50dB below the level of the fundamental or to the general radiated emissions limits in Section 15.209, whichever is the lesser attenuation, which meet the requirement of part 15.249(d).

TEST REPORT

PEAK MEASUREMENT (Bluetooth 4.0 BLE)

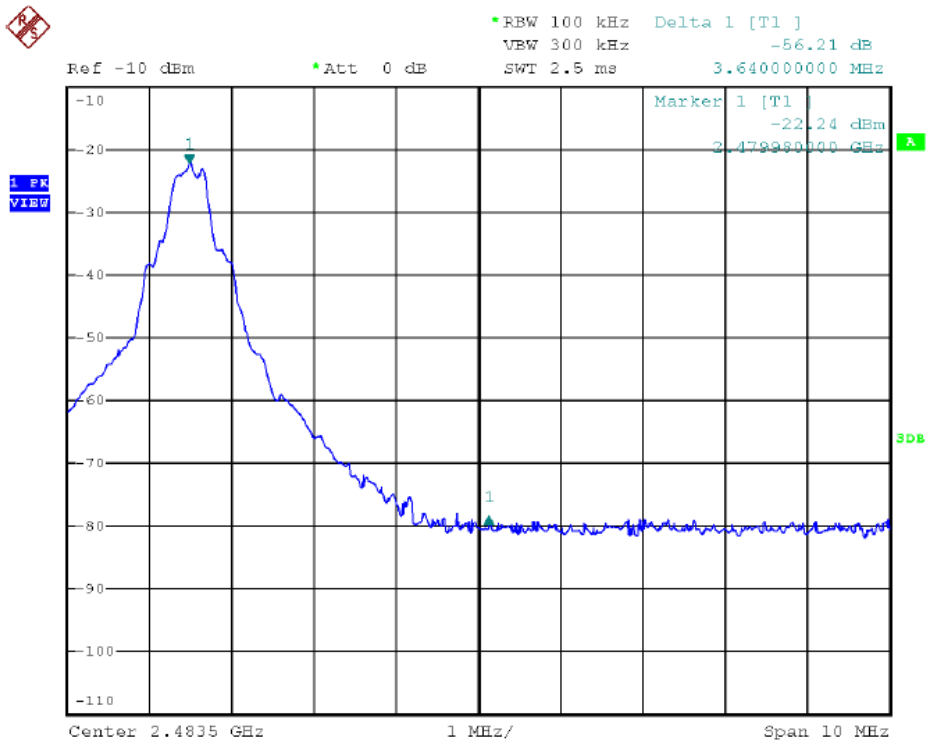
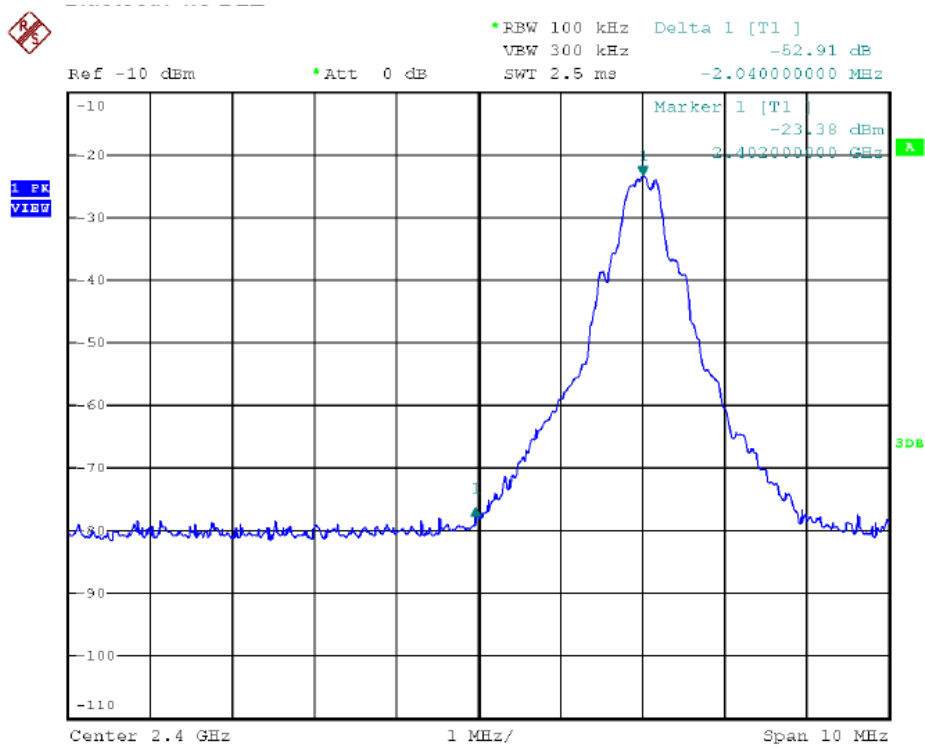

TEST REPORT

PEAK MEASUREMENT (Bluetooth 4.0 BLE)

Bandedge compliance is determined by applying marker-delta method, i.e. (Bandedge Plot).

Lower bandedge

Peak Resultant field strength = Fundamental emissions (peak value) – delta from the plot

=92.2 dB μ V/m – 52.9 dB

=39.3 dB μ V/m

Average Resultant field strength = Fundamental emissions (average value) – delta from the plot

=92.2 dB μ V/m – 52.9 dB

=39.3 dB μ V/m

Upper bandedge

Peak Resultant field strength = Fundamental emissions (peak value) – delta from the plot

=92.5 dB μ V/m – 56.2 dB

=36.3 dB μ V/m

Average Resultant field strength = Fundamental emissions (average value) – delta from the plot

=92.5 dB μ V/m – 56.2 dB

=36.3 dB μ V/m

The resultant field strength meets the general radiated emission limit in Section 15.209, which does not exceed 74 dB μ V/m (Peak Limit) and 54 dB μ V/m (Average Limit).

TEST REPORT

8.2 Discussion of Pulse Desensitization

Pulse desensitivity is not applicable for this device. The effective period (T_{eff}) is approximately $380\mu s$ for a digital "1" bit which illustrated on technical specification, with a resolution bandwidth (3dB) of 3MHz, so the pulse desensitivity factor is 0dB.

8.3 Calculation of Average Factor

It is not necessary to apply average factor as the measured (peak) data has been complied with average limit of the radiated emission.

TEST REPORT

8.4 Emissions Test Procedures

The following is a description of the test procedure used by Intertek Testing Services Hong Kong Ltd. in the measurements of transmitter operating under the Part 15, Subpart C rules.

The transmitting equipment under test (EUT) is placed on a wooden turntable which is four feet in diameter and approximately 0.8m in height above the ground plane for emission measurement at or below 1GHz and 1.5m in height above the ground plane for emission measurement above 1GHz. During the radiated emissions test, the turntable is rotated and any cables leaving the EUT are manipulated to find the configuration resulting in maximum emissions. The EUT is adjusted through all three orthogonal axis to obtain maximum emission levels. The antenna height and polarization are also varied during the testing to search for maximum signal levels. The height of the antenna is varied from one to four meters.

Detector function for radiated emissions is in peak mode. Average readings, when required, are taken by measuring the duty cycle of the equipment under test and subtracting the corresponding amount in dB from the measured peak readings. A detailed description for the calculation of the average factor can be found in Exhibit 8.3.

The frequency range scanned is from the lowest radio frequency signal generated in the device which is greater than 9 kHz to the tenth harmonic of the highest fundamental frequency or 40 GHz, whichever is lower. For line conducted emissions, the range scanned is 150 kHz to 30 MHz.

TEST REPORT

8.4 Emissions Test Procedures (cont'd)

The EUT is warmed up for 15 minutes prior to the test.

AC power to the unit is varied from 85% to 115% nominal and variation in the fundamental emission field strength is recorded. If battery powered, a new, fully charged battery is used.

Conducted measurements were made as described in ANSI C63.10 (2013).

The IF bandwidth used for measurement of radiated signal strength was 100 kHz or greater when frequency is below 1000 MHz. Where pulsed transmissions of short enough pulse duration warrant, a greater bandwidth is selected according to the recommendations of Hewlett Packard Application Note 150-2. A discussion of whether pulse desensitivity is applicable to this unit is included in this report (See Exhibit 8.1). Above 1000 MHz, a resolution bandwidth of 3 MHz is used.

Transmitter measurements are normally conducted at a measurement distance of three meters. However, to assure low enough noise floor in the forbidden bands and above 1 GHz, signals are acquired at a distance of one meter or less. All measurements are extrapolated to three meters using inverse scaling, unless otherwise reported. Measurements taken at a closer distance are so marked.

TEST REPORT

8.4.1 Radiated Emission Test Setup

The figure below shows the test setup, which is utilized to make these measurements.

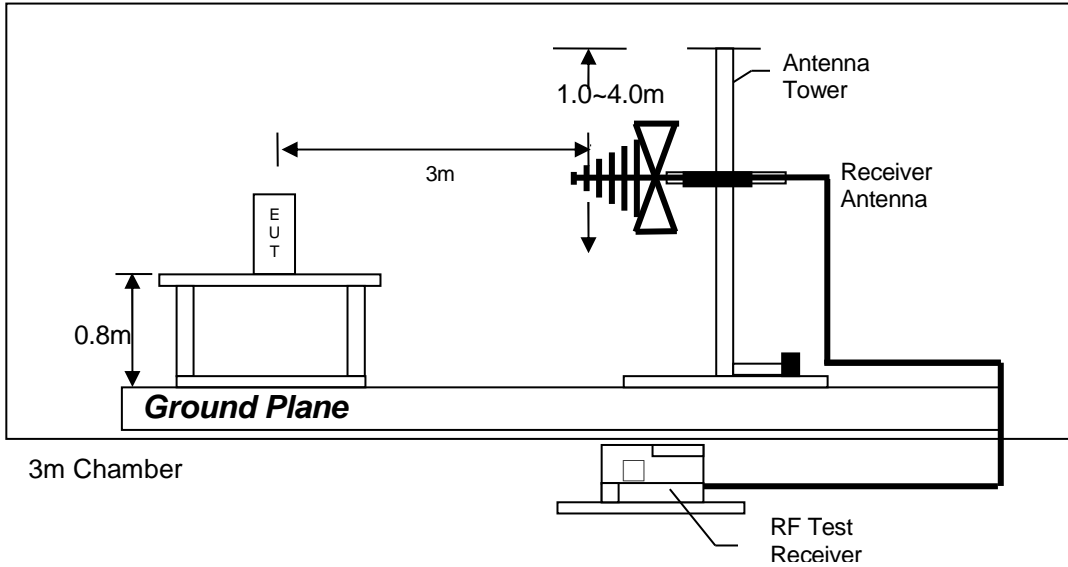

Test setup of radiated emissions up to 1GHz

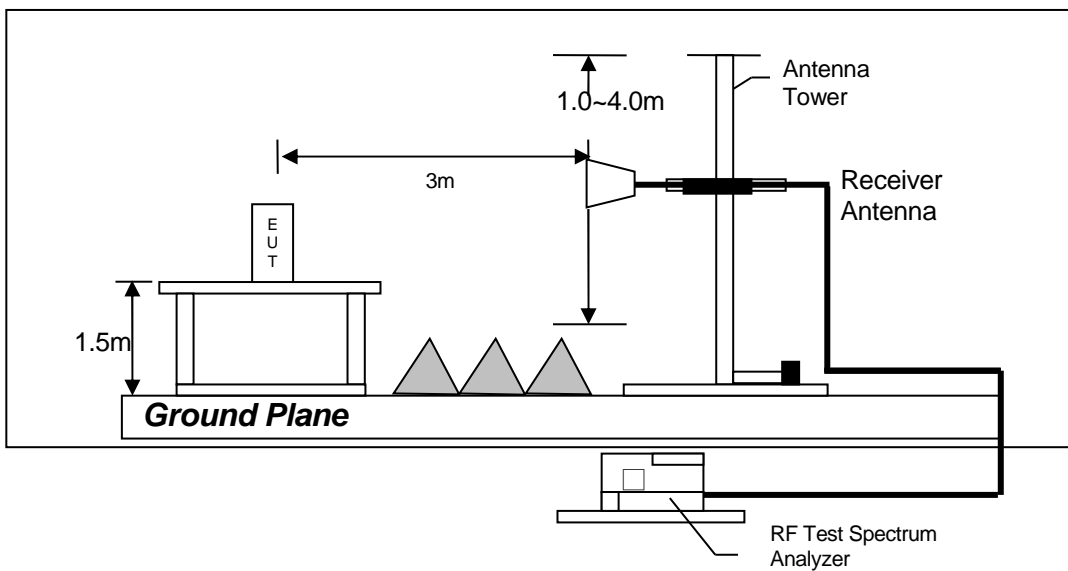

Test setup of radiated emissions above 1GHz

TEST REPORT

8.4.2 Conducted Emission Test Procedures

For tabletop equipment, the EUT along with its peripherals were placed on a 1.0m(W)×1.5m(L) and 0.8m in height wooden table. For floor-standing equipment, the EUT and all cables were insulated, if required, from the ground plane by up to 12 mm of insulating material. The EUT was adjusted to maintain a 0.4 meter space from a vertical reference plane. The EUT was connected to power mains through a line impedance stabilization network (LISN), which provided 50 ohm coupling impedance for measuring instrument and the chassis ground was bounded to the horizontal ground plane of shielded room. The excess power cable between the EUT and the LISN was bundled.

All connecting cables of EUT and peripherals were moved to find the maximum emission.

8.4.3 Conducted Emission Test Setup

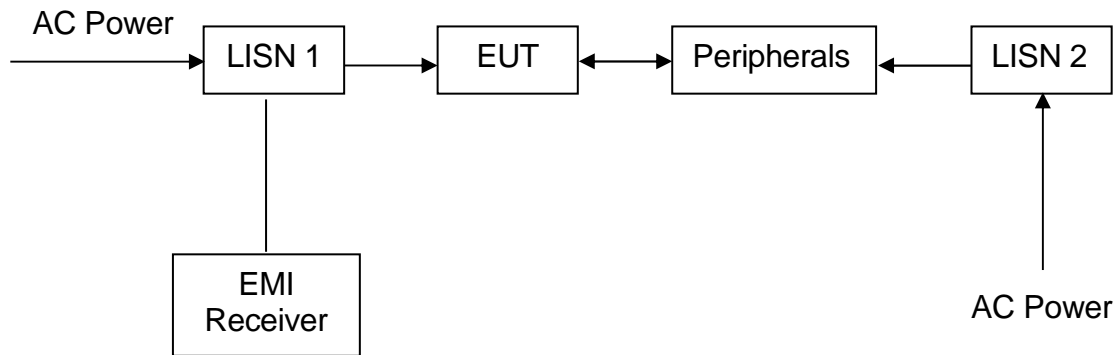

TEST REPORT

9.0 CONFIDENTIALITY REQUEST

For electronic filing, a preliminary copy of the confidentiality request is saved with filename: request.pdf.

10.0 EQUIPMENT LIST

1) Radiated Emissions Test

EQUIPMENT	EMI Test Receiver	BICONICAL ANTENNA	LOG PERIODIC ANTENNA
Registration No.	EW-2500	EW-0571	EW-1042
Manufacturer	ROHDESCHWARZ	EMCO	EMCO
Model No.	ESCI	3104C	3148
Calibration Date	Oct. 13, 2017	Feb. 27, 2018	Jun. 19, 2017
Calibration Due Date	Oct. 13, 2018	Aug. 27, 2019	Dec. 19, 2018

EQUIPMENT	SPECTRUM ANALYZER	Pyramidal Horn Antenna	DOUBLE RIDGED GUIDE ANTENNA
Registration No.	EW-2253	EW-0905	EW-1015
Manufacturer	ROHDESCHWARZ	EMCO	EMCO
Model No.	FSP40	3160-09	3115
Calibration Date	Jul. 24, 2017	Aug. 18, 2017	Nov. 17, 2017
Calibration Due Date	Jul. 24, 2018	Feb. 18, 2019	May. 17, 2019

Equipment	Active Loop H-field (9kHz to 30MHz)	12m Double Shield RF Cable (20MHz to 6GHz)	RF Cable 14m (1GHz to 26.5GHz)
Registration No.	EW-3326	EW1852	EW-2781
Manufacturer	EMCO	RADIALL	GREATBILLION
Model No.	6502	N(m)-RG142 - N(m)	SMA m/SHF5MPU /SMA m ra14m,26G
Calibration Date	Sep. 27, 2017	Jan. 19, 2018	Sep. 25, 2017
Calibration Due Date	Mar. 27, 2019	Jan. 19, 2019	Sep. 25, 2018

Equipment	RF PRE-AMPLIFIER 3 PCS (9KHZ TO 40GHZ)
Registration No.	EW-3229
Manufacturer	BONN ELEKTRO
Model No.	BLMA 0118-5G
Calibration Date	Jan. 30, 2018
Calibration Due Date	Jan. 30, 2019

TEST REPORT

2) Conducted Emissions Test

Equipment	EMI Test Receiver	RF Cable 120cm (RG142) (9kHz to 30MHz)	Artificial Mains Network
Registration No.	EW-3156	EW-2453	EW-0192
Manufacturer	R&S	RADIALL	ROHDESCHWARZ
Model No.	ESR26	bnc m st / 142 / bnc m st 100c	ESH3-Z5
Calibration Date	November 10, 2017	Sep. 15, 2017	Oct. 27, 2017
Calibration Due Date	November 10, 2018	Sep. 15, 2018	Aug. 25, 2018

3) Bandedge Measurement

EQUIPMENT	RF Cable 30cm (1-26)GHz	SPECTRUM ANALYZER
Registration No.	EW-2268	EW-2253
Manufacturer	RADIALL	ROHDESCHWARZ
Model No.	SMA(M)/SHF5M/SMA(M)30cm	FSP40
Calibration Date	Aug. 23, 2017	Jul. 24, 2017
Calibration Due Date	Aug. 23, 2018	Jul. 24, 2018

END OF TEST REPORT