

FCC Test Report

Product Name : REMOTE CONTROLLER
 Model No. : 28595 MV104
 FCC ID. : 2ABPM28595-MV104

Applicant : Whetron electronic Co., Ltd.
 Address : No.16, Singye Rd., Ta Fa Ind., Daliao Dist.,
 Kaohsiung City 831, Taiwan (R.O.C.)

Date of Receipt : 2014/01/06
 Issued Date : 2014/01/17
 Report No. : 1410158R-RFUSP14V00
 Report Version : V1.0



The test results relate only to the samples tested.
 The test report shall not be reproduced except in full without the written approval of QuieTek Corporation.

Test Report Certification

Issued Date : 2014/01/17

Report No. : 1410158R-RFUSP14V00



Product Name : REMOTE CONTROLLER
 Applicant : Whetron electronic Co., Ltd.
 Address : No.16, Singye Rd., Ta Fa Ind., Daliao Dist., Kaohsiung City
 831, Taiwan (R.O.C.)
 Manufacturer : Whetron electronic Co., Ltd.
 Model No. : 28595 MV104
 FCC ID. : 2ABPM28595-MV104
 EUT Voltage : DC 3V
 Trade Name : LUXGEN
 Applicable Standard : FCC 15 Subpart C Section 15.231(b): 2012
 Test Result : Complied

The test results relate only to the samples tested.

The test report shall not be reproduced except in full without the written approval of Quietek Corporation.

This report must not be used to claim product endorsement by NVLAP any agency of the U.S. Government

Documented By :

(Demi Chang / Engineering Adm. Specialist)

Reviewed By :

(Quale Tang / Senior Engineer)

Approved By :

(Roy Wang / Director)

Laboratory Information

We, **Quietek Corporation**, are an independent RF consultancy that was established the whole facility in our laboratories. The test facility has been accredited/accepted (audited or listed) by the following related bodies in compliance with ISO 17025 specified testing scopes:

Taiwan R.O.C.	:	TAF, Accreditation Number: 1313
USA	:	FCC, Registration Number: 365520
Canada	:	IC, Submission No: 150981

The related certificate for our laboratories about the test site and management system can be downloaded from Quietek Corporation's Web Site:<http://www.quietek.com/tw/ctg/cts/accreditations.htm>

The address and introduction of Quietek Corporation's laboratories can be founded in our Web site : <http://www.quietek.com/>

If you have any comments, Please don't hesitate to contact us. Our contact information is as below:

HsinChu Testing Laboratory:

No.75-2, 3rd Lin, Wangye Keng, Yonghxing Tsuen, Qionglin Shiang, Hsinchu County 307, Taiwan, R.O.C.
 TEL:+886-3-592-8858 / FAX:+886-3-592-8859 E-Mail : service@quietek.com

Linkou Testing Laboratory:

No.5-22, Ruishukeng, Linkou Dist., New Taipei City 24451, Taiwan, R.O.C.
 TEL : 886-2-8601-3788 / FAX : 886-2-8601-3789 E-Mail : service@quietek.com

TABLE OF CONTENTS

Description	Page
1. General Information.....	5
1.1. EUT Description	5
1.2. Operation Description.....	6
1.3. Test Mode	7
1.4. Tested System Details	8
1.5. Configuration of tested System	8
1.6. EUT Exercise Software	8
1.7. Test Facility.....	9
2. Radiated Emission.....	10
2.1. Test Equipment.....	10
2.2. Test Setup	11
2.3. Limits	12
2.4. Test Procedure	13
2.5. Test Specification.....	13
2.6. Uncertainty	13
2.7. Test Result.....	14
2.8. Test Photo	19
3. Occupied Bandwidth.....	21
3.1. Test Equipment.....	21
3.2. Test Setup	21
3.3. Limits	21
3.4. Test Specification.....	21
3.5. Uncertainty	21
3.6. Test Result.....	22
4. Duty cycle	23
4.1. Test Equipment.....	23
4.2. Test Setup	23
4.3. Limits	23
4.4. Test Specification.....	23
4.5. Uncertainty	23
4.6. Test Result.....	24
5. Transmitter time	26
5.1. Test Equipment.....	26
5.2. Test Setup	26
5.3. Limits	26
5.4. Test Specification.....	26
5.5. Uncertainty	26
5.6. Test Result.....	27
Attachment.....	28
EUT Photograph.....	28

1. General Information

1.1. EUT Description

Product Name	REMOTE CONTROLLER
Trade Name	LUXGEN
Model No.	28595 MV104
Frequency Range/Channel Number	315 MHz / 1 Channel
Antenna Gain	0dBi
Type of Modulation	ASK
Antenna Type	Soldered on PCB

Working Frequency of Each Channel	
Channel	Frequency
01	315MHz

Note:

1. This device is a REMOTE CONTROLLER included a 315MHz transmitter function.
2. These tests are conducted on a sample for the purpose of demonstrating compliance with Part 15 Subpart C Paragraph 15.231.
3. The radiation measurements are performed in X, Y, Z axis positioning. Only the worst case is shown in the report.

1.3. Test Mode

QuieTek verified the construction and function in typical operation. All the test modes are performed in normal operation and are defined as:

Pre-Test Mode	
TX	Mode 1: Transmit
Final Test Mode	
TX	Mode 1: Transmit

Emission	
Performed Item	
Conducted Emission	No
Radiated Emission	Yes
Occupied Bandwidth	Yes
Duty cycle	Yes
Transmitter time	Yes

1.4. Tested System Details

The types for all equipments, plus descriptions of all cables used in the tested system (including inserted cards) are:

N/A

1.5. Configuration of tested System

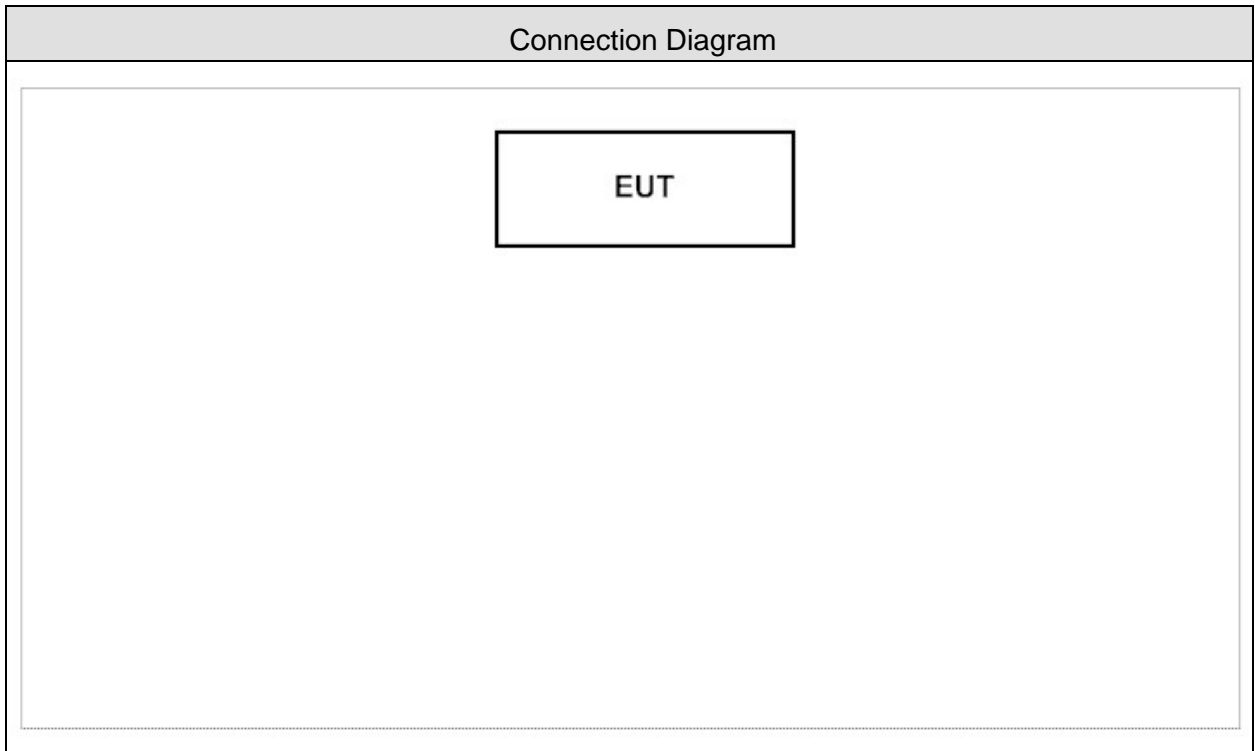

1.6. EUT Exercise Software

1	Setup the EUT as shown in section 1.5.
2	Turn on the EUT power.
3	The RF signal's status will continue transmit through EUT.
4	Repeat the above procedure.

1.7. Test Facility

Ambient conditions in the laboratory:

Items	Test Item	Required (IEC 68-1)	Actual
Temperature (°C)	FCC PART 15 C 15.231 Radiated Emission	15 - 35	25
Humidity (%RH)		25 - 75	50
Barometric pressure (mbar)		860 - 1060	950-1000
Temperature (°C)	FCC PART 15 C 15.231 Occupied Bandwidth	15 - 35	25
Humidity (%RH)		25 - 75	50
Barometric pressure (mbar)		860 - 1060	950-1000
Temperature (°C)	FCC PART 15 C 15.231 Duty Cycle	15 - 35	25
Humidity (%RH)		25 - 75	50
Barometric pressure (mbar)		860 - 1060	950-1000
Temperature (°C)	FCC PART 15 C 15.231 Transmitter Time	15 - 35	25
Humidity (%RH)		25 - 75	50
Barometric pressure (mbar)		860 - 1060	950-1000

2. Radiated Emission

2.1. Test Equipment

The following test equipments are used during the test:

Radiated Emission / CB1

Instrument	Manufacturer	Model No.	Serial No	Next Cal. Date
Bilog Antenna	SCHAFFNER	CBL6112B	2895(CB1)	2014/08/14
Double Ridged Guide Horn Antenna	Schwarzback	BBHA 9120	D743	2014/02/17
Pre-Amplifier	MITEQ	AMF-4D	888003	2014/06/09
Pre-Amplifier	QuieTek	AP-025C	CHM-0706049	2014/02/19
Spectrum Analyzer	Agilent	E4440A	MY46187335	2014/01/27
k Type Cable	Huber Suhner	Sucoflex 102	25623/2	2014/02/21

Note: 1. All equipments that need to calibrate are with calibration period of 1 year.

2.2. Test Setup

Under 1GHz Test Setup:

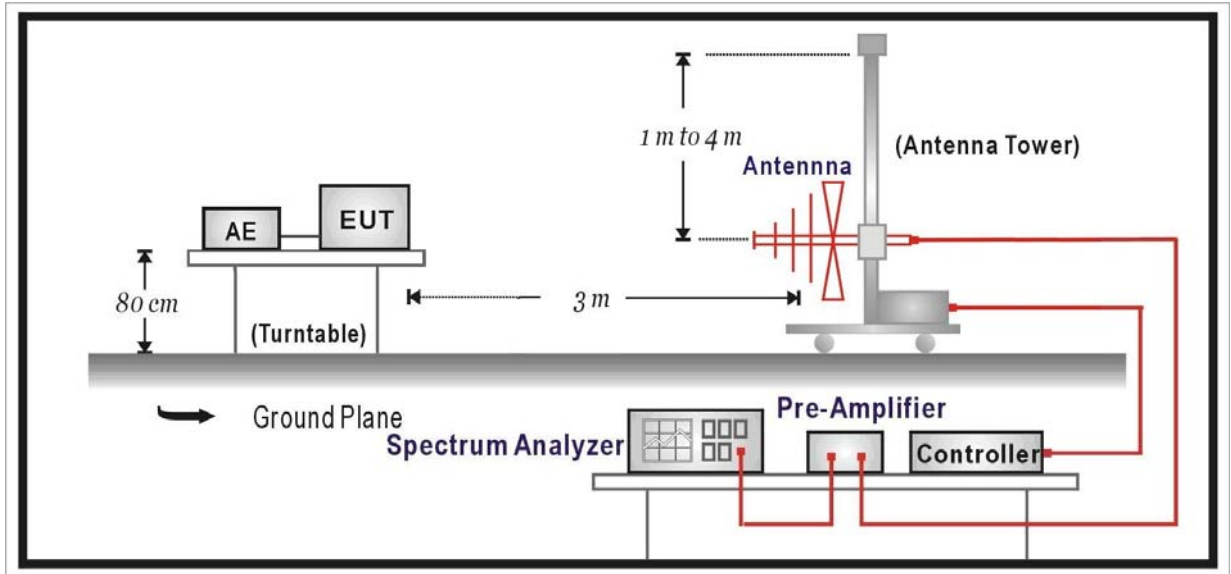

Above 1GHz Test Setup:

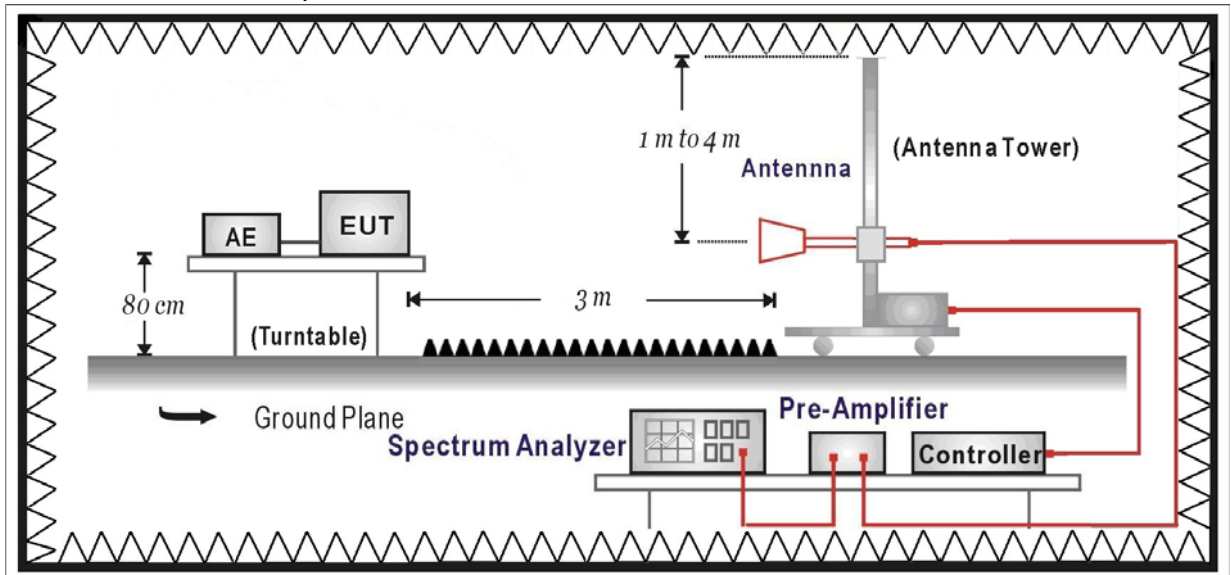

2.3. Limits

➤ Fundamental and Harmonics Emission Limits

FCC Part 15 Subpart C Paragraph 15.231(b) Limits				
Fundamental Frequency MHz	Field Strength of Fundamental		Field Strength of Harmonics	
	uV/m	dBuV/m	uV/m	dBuV/m
40.66-40.70	2250	67.04	225	47.04
70-130	1250	61.94	125	41.94
130-174	1250-3750	61.94-71.48	125-375	41.94-51.48
174-260	3750	71.48	375	51.48
260-470	3750-12500	71.48-81.94	375-1250	51.48-61.94
above 470	12500	81.94	1250	61.94

- Remarks: 1. RF Voltage (dBuV) = 20 log RF Voltage (uV)
 2. Distance refers to the distance in meters between the measuring instrument antenna and the closed point of any part of the device or system.
 3. The emission limit in this paragraph is based on measurement instrumentation employing an average detector.

➤ Spurious electric field strength limits

FCC Part 15 Subpart C Paragraph 15.209 Limits			
Frequency MHz	uV/m	dBuV/m	Measurement distance (meter)
0.009-0.490	2400/F(kHz)	See Remark ¹	300
0.490-1.705	24000/F(kHz)	See Remark ¹	30
1.705-30	30	29.5	30
30-88	100	40	3
88-216	150	43.5	3
216-960	200	46	3
Above 960	500	54	3

- Remarks : 1. RF Voltage (dBuV) = 20 log RF Voltage (uV)
 2. In the Above Table, the tighter limit applies at the band edges.
 3. Distance refers to the distance in meters between the measuring instrument antenna and the closed point of any part of the device or system.

2.4. Test Procedure

The EUT and its simulators are placed on a turn table which is 0.8 meter above ground. The turn table can rotate 360 degrees to determine the position of the maximum emission level. The EUT was positioned such that the distance from antenna to the EUT was 3 meters.

The antenna can move up and down between 1 meter and 4 meters to find out the maximum emission level.

Both horizontal and vertical polarizations of the antenna are set on measurement. In order to find the maximum emission, all of the interface cables must be manipulated according to ANSI C63.4: 2009 on radiated measurement.

The resolution bandwidth below 1GHz setting on the field strength meter is 120 kHz and above 1GHz is 1MHz.

Radiated emission measurements below 1GHz are made using broadband Bilog antenna and above 1GHz are made using Horn Antennas.

The measurement is divided into the Preliminary Measurement and the Final Measurement.

The suspected frequencies are searched for in Preliminary Measurement with the measurement antenna kept pointed at the source of the emission both in azimuth and elevation, with the polarization of the antenna oriented for maximum response. The antenna is pointed at an angle towards the source of the emission, and the EUT is rotated in both height and polarization to maximize the measured emission. The emission is kept within the illumination area of the 3 dB beamwidth of the antenna.

The worst radiated emission is measured on the Final Measurement.

The frequency range from 30MHz to 10th harmonics is checked.

2.5. Test Specification

According to FCC Part 15 Subpart C Paragraph 15.231(b): 2012

2.6. Uncertainty

± 3.8 dB below 1GHz

± 3.9 dB above 1GHz

2.7. Test Result

Product	REMOTE CONTROLLER		
Test Item	Fundamental Radiated Emission		
Test Mode	Mode 1: Transmit		
Date of Test	2014/01/14	Test Site	CB1

Frequency (MHz)	Correct Factor (dB)	Reading Level (dBuV)	Peak Measurement Level (dBuV/m)	Average Measurement Level (dBuV/m)	Peak Limit (dBuV/m)	Average Limit (dBuV/m)
Horizontal						
315.000 (X-axis)	13.113	58.409	71.522	63.095	95.623	75.623
315.000 (Y-axis)	13.113	43.690	56.803	48.376	95.623	75.623
315.000 (Z-axis)	13.113	53.919	67.032	58.605	95.623	75.623
Vertical						
315.000 (X-axis)	13.113	43.140	56.253	47.826	95.623	75.623
315.000 (Y-axis)	13.113	57.909	71.022	62.595	95.623	75.623
315.000 (Z-axis)	13.113	55.168	68.281	59.854	95.623	75.623

Note1:

Peak Measurement Level = Reading Level + Correct Factor

Average Measurement Level = Peak Measurement Level + 20Log (Duty Cycle)

Duty Cycle(Only Ton)= Ton/ Ton+off=(0.468 μ s/0.987 μ s)=0.474

Duty Cycle=(Ton/(Ton+Toff))* Duty Cycle(Only Ton) =(80ms/100ms)*0.474=0.379

20*Log(Duty Cycle) = -8.427

30MHz-1GHz Spurious :

Site : CB1	Time : 2014/01/14 - 19:08
Limit : FCC_SpartC_15.231(B)_H_315MHz_03M_PK	Margin : 6
Probe : CB1_FCC_EFS_30-1G-2_1011 - HORIZONTAL	Power : DC 3V
EUT : REMOTE CONTROLLER	Note : Axis-X

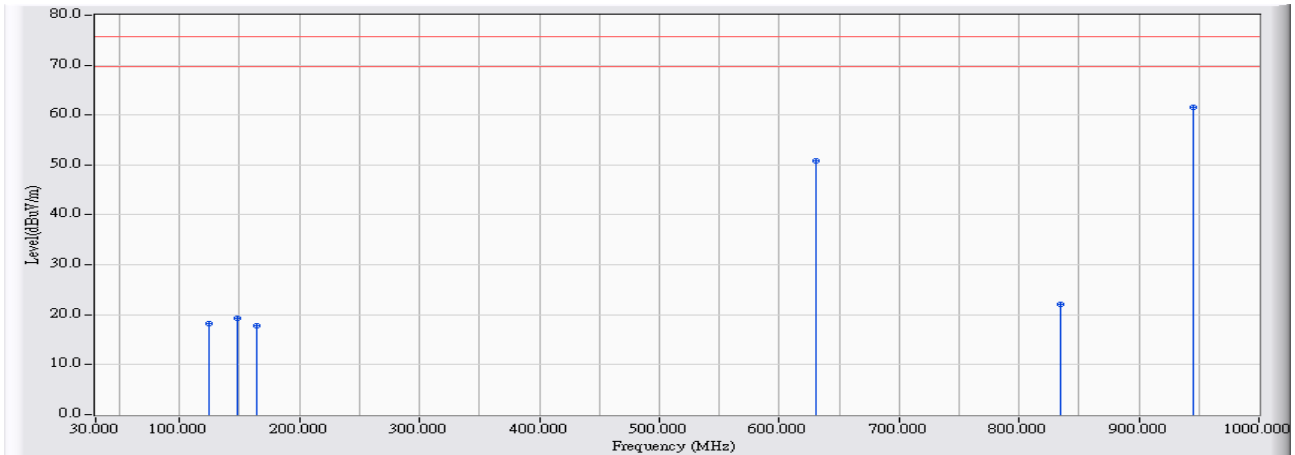

	Frequency (MHz)	Correct Factor (dB)	Reading Level (dBuV)	Measure Level (dBuV/m)	Margin (dB)	Limit (dBuV/m)	Detector Type
1	124.090	-22.322	40.525	18.202	-57.421	75.623	PEAK
2	148.340	-23.284	42.540	19.257	-56.366	75.623	PEAK
3	163.860	-24.033	41.809	17.776	-57.847	75.623	PEAK
4	630.430	-15.362	66.169	50.807	-24.816	75.623	PEAK
5	834.130	-13.498	35.570	22.072	-53.551	75.623	PEAK
6	* 945.680	-13.001	74.535	61.535	-14.088	75.623	PEAK

Note:

- All reading above 1GHz are performed with peak and/or average measurements as necessary.
- Peak measurement :RBW=1MHz,VBW=3MHz,Sweep:Auto.
- " * ", means this data is the worst emission level.
- Measurement Level = Reading Level + Correct Factor.
- Average Measurement Level = Peak Measurement Level + 20Log (Duty Cycle)
 Duty Cycle(Only Ton)= Ton/ Ton+off=(0.468 μs/0.987 μs)=0.474
 Duty Cycle=(Ton/(Ton+Toff))* Duty Cycle(Only Ton) =(80ms/100ms)*0.474=0.379
 20*Log(Duty Cycle) = -8.427
- The average measurement was not performed when the peak measured data under the limit of peak detection.

Site : CB1	Time : 2014/01/14 - 19:11
Limit : FCC_SpartC_15.231(B)_H_315MHz_03M_PK	Margin : 6
Probe : CB1_FCC_EFS_30-1G-2_1011 - VERTICAL	Power : DC 3V
EUT : REMOTE CONTROLLER	Note : Axis- X

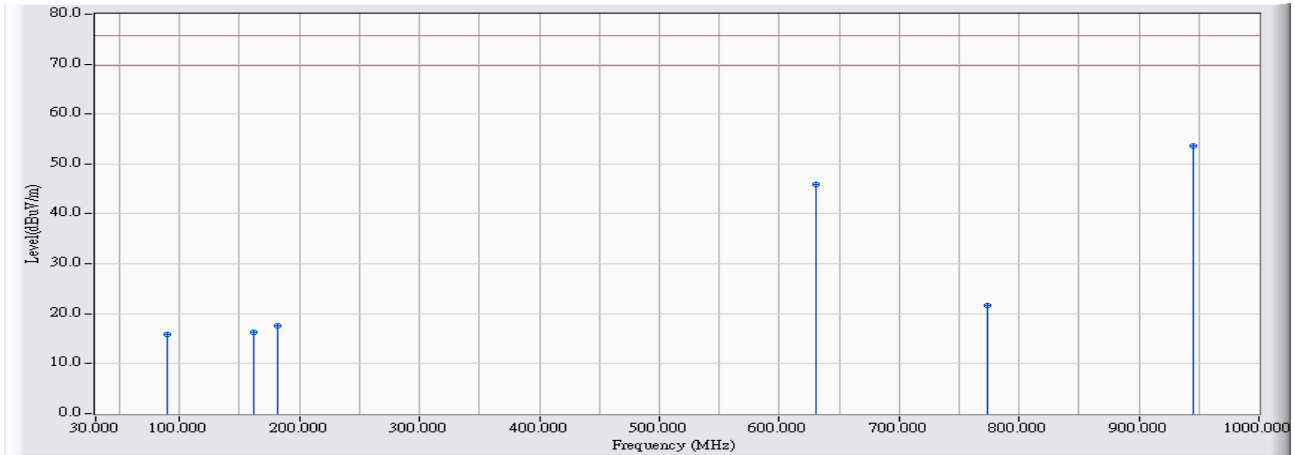

	Frequency (MHz)	Correct Factor (dB)	Reading Level (dBuV)	Measure Level (dBuV/m)	Margin (dB)	Limit (dBuV/m)	Detector Type
1	90.140	-25.468	41.392	15.923	-59.700	75.623	PEAK
2	161.920	-23.947	40.232	16.284	-59.339	75.623	PEAK
3	181.320	-24.746	42.300	17.554	-58.069	75.623	PEAK
4	630.430	-15.362	61.214	45.852	-29.771	75.623	PEAK
5	773.990	-13.956	35.588	21.632	-53.991	75.623	PEAK
6	* 945.680	-13.001	66.569	53.569	-22.054	75.623	PEAK

Note:

- All reading above 1GHz are performed with peak and/or average measurements as necessary.
- Peak measurement :RBW=1MHz,VBW=3MHz,Sweep:Auto.
- " * ", means this data is the worst emission level.
- Measurement Level = Reading Level + Correct Factor.
- Average Measurement Level = Peak Measurement Level + 20Log (Duty Cycle)
 Duty Cycle(Only Ton)= Ton/ Ton+off=(0.468 μs/0.987 μs)=0.474
 Duty Cycle=(Ton/(Ton+Toff))* Duty Cycle(Only Ton) =(80ms/100ms)*0.474=0.379
 20*Log(Duty Cycle) = -8.427
- The average measurement was not performed when the peak measured data under the limit of peak detection.

Above 1GHz Spurious:

Site : CB1	Time : 2014/01/14 - 19:28
Limit : FCC_SpartC_15.231(B)_H_315MHz_03M_PK	Margin : 6
Probe : CB4_FCC_EFS_1-18G-1_0901 - HORIZONTAL	Power : DC 3V
EUT : REMOTE CONTROLLER	Note : Axis- X

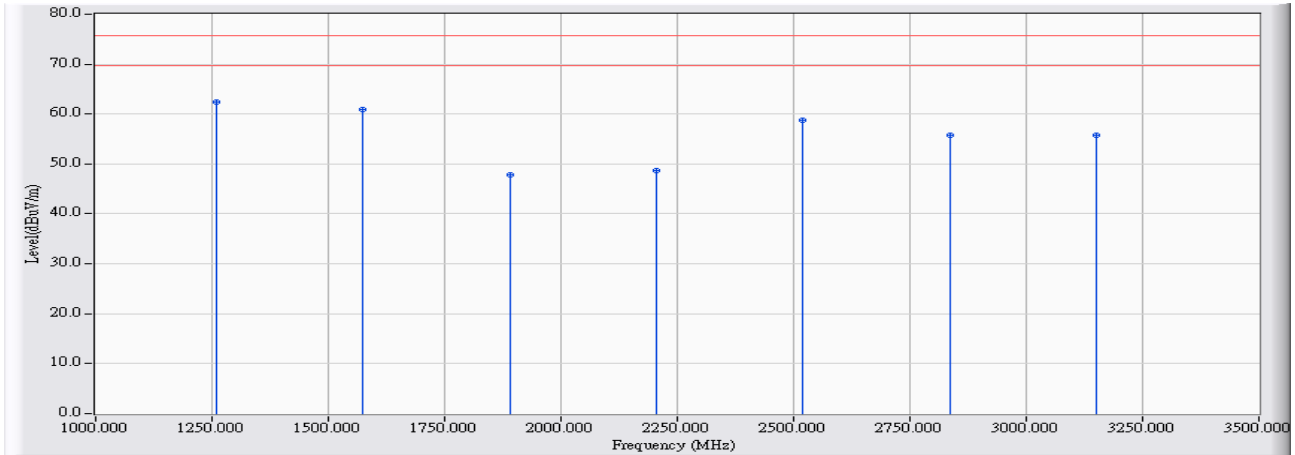

		Frequency (MHz)	Correct Factor (dB)	Reading Level (dBuV)	Measure Level (dBuV/m)	Margin (dB)	Limit (dBuV/m)	Detector Type
1	*	1260.000	-11.530	73.972	62.442	-13.181	75.623	PEAK
2		1575.000	-10.445	71.339	60.894	-14.729	75.623	PEAK
3		1890.000	-9.697	57.478	47.781	-27.842	75.623	PEAK
4		2205.000	-7.621	56.291	48.670	-26.953	75.623	PEAK
5		2520.000	-5.044	63.913	58.869	-16.754	75.623	PEAK
6		2835.000	-5.595	61.406	55.811	-19.812	75.623	PEAK
7		3150.000	-5.757	61.554	55.797	-19.826	75.623	PEAK

Note:

1. All readings above 1GHz are performed with peak and/or average measurements as necessary.
2. Peak measurements: RBW = 1MHz, VBW = 3 MHz, Sweep: Auto.
3. “ * ”, means this data is the worst emission level.
4. Measurement Level = Reading Level + Correct Factor.
5. Average Measurement Level = Peak Measurement Level + 20Log (Duty Cycle)
 Duty Cycle(Only Ton)= Ton/ Ton+off=(0.468 μ s/0.987 μ s)=0.474
 Duty Cycle=(Ton/(Ton+Toff))* Duty Cycle(Only Ton) =(80ms/100ms)*0.474=0.379
 20*Log(Duty Cycle) = -8.427
6. The average measurement was not performed when the peak measured data under the limit of peak detection.

Site : CB1	Time : 2014/01/14 - 19:30
Limit : FCC_SpartC_15.231(B)_H_315MHz_03M_PK	Margin : 6
Probe : CB4_FCC_EFS_1-18G-1_0901 - VERTICAL	Power : DC 3V
EUT : REMOTE CONTROLLER	Note : Axis- X

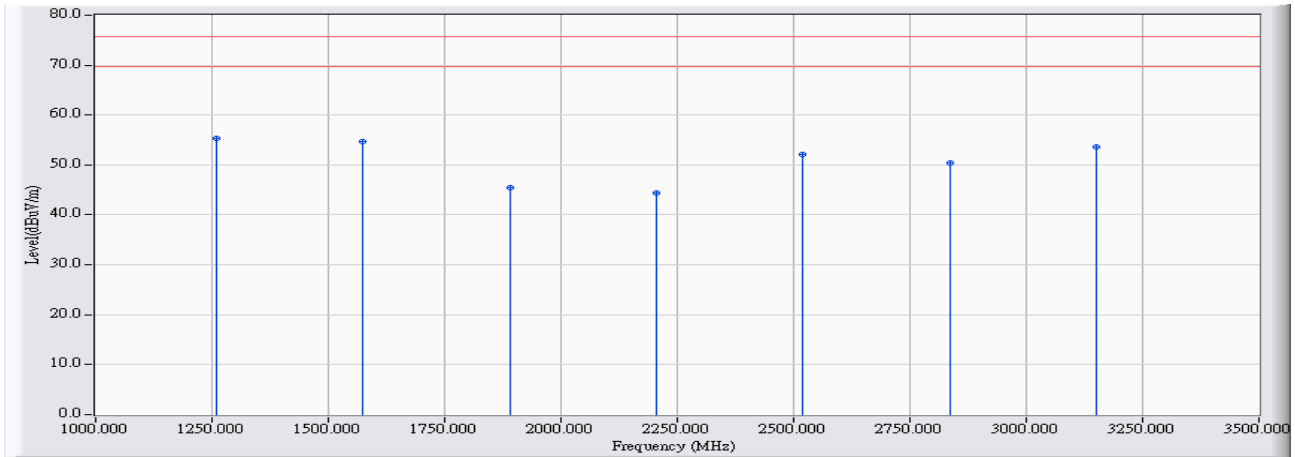

		Frequency (MHz)	Correct Factor (dB)	Reading Level (dBuV)	Measure Level (dBuV/m)	Margin (dB)	Limit (dBuV/m)	Detector Type
1	*	1260.000	-11.530	66.961	55.431	-20.192	75.623	PEAK
2		1575.000	-10.445	65.114	54.669	-20.954	75.623	PEAK
3		1890.000	-9.697	55.111	45.414	-30.209	75.623	PEAK
4		2205.000	-7.621	52.125	44.504	-31.119	75.623	PEAK
5		2520.000	-5.044	57.245	52.201	-23.422	75.623	PEAK
6		2835.000	-5.595	56.059	50.464	-25.159	75.623	PEAK
7		3150.000	-5.757	59.454	53.697	-21.926	75.623	PEAK

Note:

1. All readings above 1GHz are performed with peak and/or average measurements as necessary.
2. Peak measurements: RBW = 1MHz, VBW = 3 MHz, Sweep: Auto.
3. “ * ”, means this data is the worst emission level.
4. Measurement Level = Reading Level + Correct Factor.
5. Average Measurement Level = Peak Measurement Level + 20Log (Duty Cycle)
 Duty Cycle(Only Ton)= Ton/ Ton+off=(0.468 μ s/0.987 μ s)=0.474
 Duty Cycle=(Ton/(Ton+Toff))* Duty Cycle(Only Ton) =(80ms/100ms)*0.474=0.379
 20*Log(Duty Cycle) = -8.427
6. The average measurement was not performed when the peak measured data under the limit of peak detection.

3. Occupied Bandwidth

3.1. Test Equipment

The following test equipments are used during the radiated emission tests:

Occupied Bandwidth / SR7

Instrument	Manufacturer	Model No.	Serial No	Next Cal. Date
Spectrum Analyzer	Agilent	N9010A-EXA	US47140172	2014/08/05

Note: 1. All equipments that need to calibrate are with calibration period of 1 year.

3.2. Test Setup

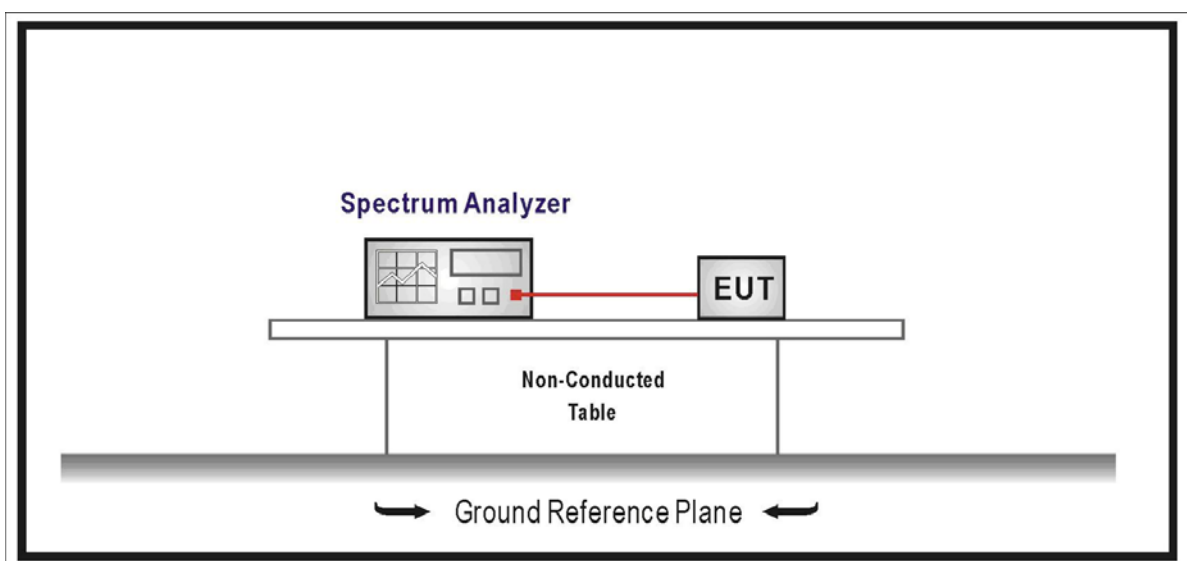

3.3. Limits

The bandwidth of the emission shall be no wider than 0.25% of the center frequency for devices operating above 70 MHz and below 900 MHz. For devices operating above 900 MHz, the emission shall be no wider than 0.5% of the center frequency. Bandwidth is determined at the points 20 dB down from the modulated carrier.

3.4. Test Specification

According to FCC Part 15 Subpart C Paragraph 15.231(b): 2012

3.5. Uncertainty

± 150Hz

3.6. Test Result

Product	REMOTE CONTROLLER		
Test Item	Occupied Bandwidth		
Test Mode	Mode 1: Transmit		
Date of Test	2014/01/08	Test Site	SR7

Center Frequency	315 MHz
Allowable Bandwidth (315 MHz: 0.25%)	787.5 kHz
Bandwidth at 20dB down (Max)	260 kHz
Result	PASS

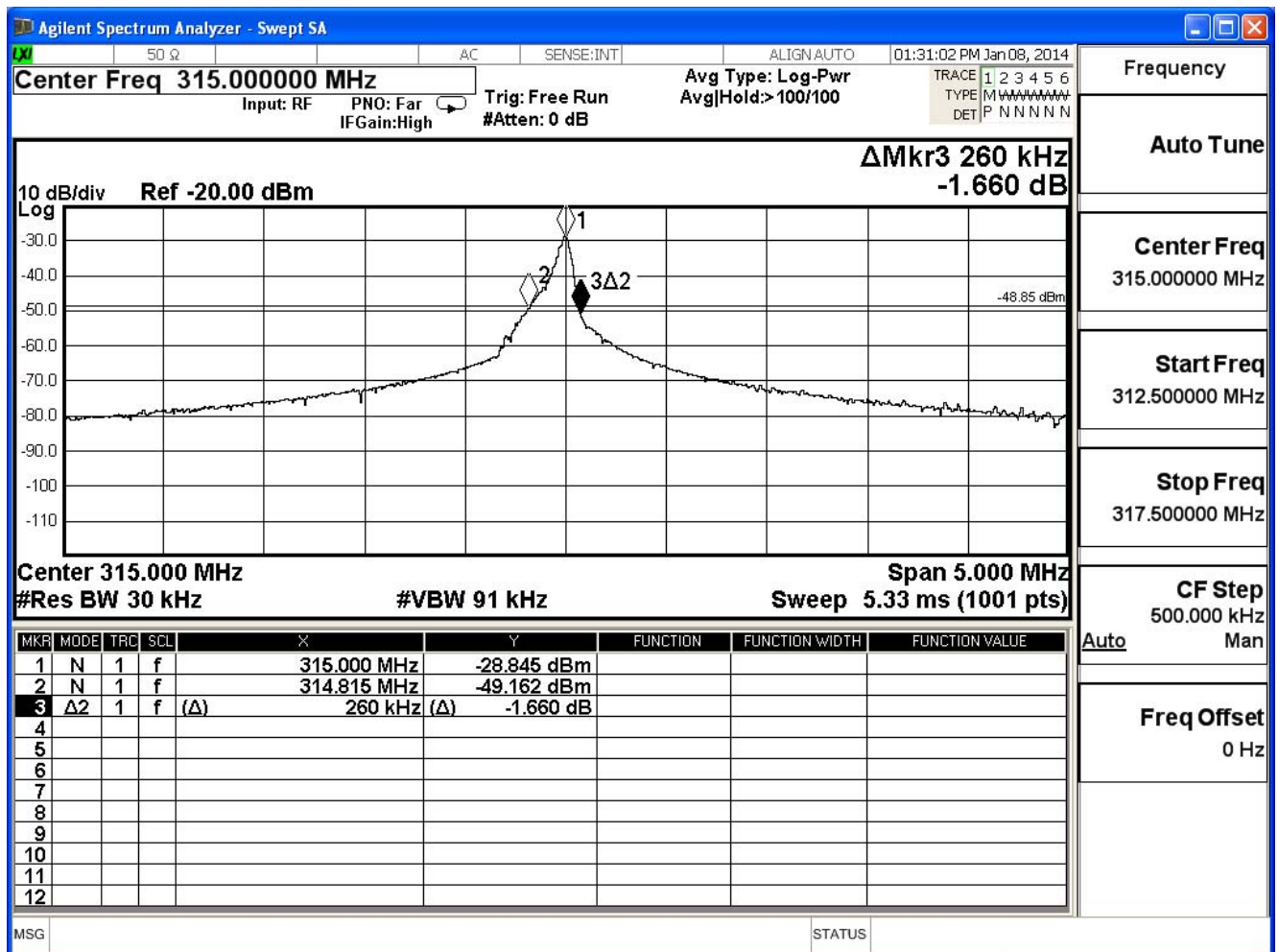

4. Duty cycle

4.1. Test Equipment

The following test equipments are used during the radiated emission tests:

Duty cycle / SR7

Instrument	Manufacturer	Model No.	Serial No	Next Cal. Date
Spectrum Analyzer	Agilent	N9010A-EXA	US47140172	2014/08/05

Note: 1. All equipments that need to calibrate are with calibration period of 1 year.

4.2. Test Setup

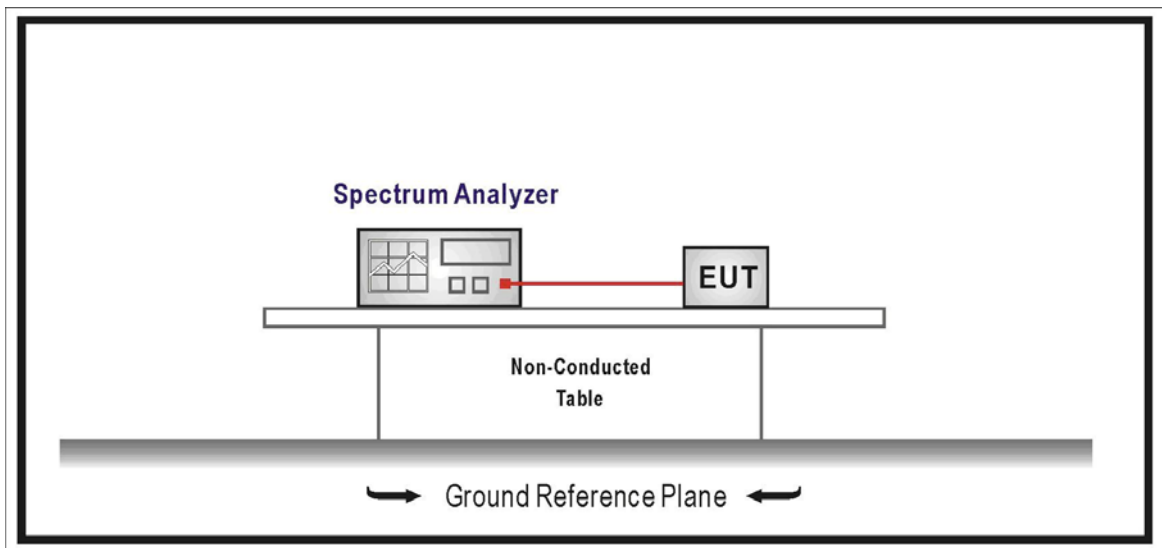

4.3. Limits

N/A

4.4. Test Specification

According to FCC Part 15 Subpart C Paragraph 15.231(b): 2012

4.5. Uncertainty

± 25msec

4.6. Test Result

Product	REMOTE CONTROLLER		
Test Item	Duty Cycle		
Test Mode	Mode 1: Transmit		
Date of Test	2014/01/08	Test Site	SR7

Center Frequency	315.00 MHz
Duty Cycle(Only Ton) $= \text{Ton} / \text{Ton} + \text{off} = (0.468 \mu\text{s} / 0.987 \mu\text{s})$ $= 0.474$	
Duty Cycle $= (\text{Ton} / (\text{Ton} + \text{Toff})) * \text{Duty Cycle(Only Ton)} = (80\text{ms} / 100\text{ms}) * 0.474$ $= 0.379$	

100ms

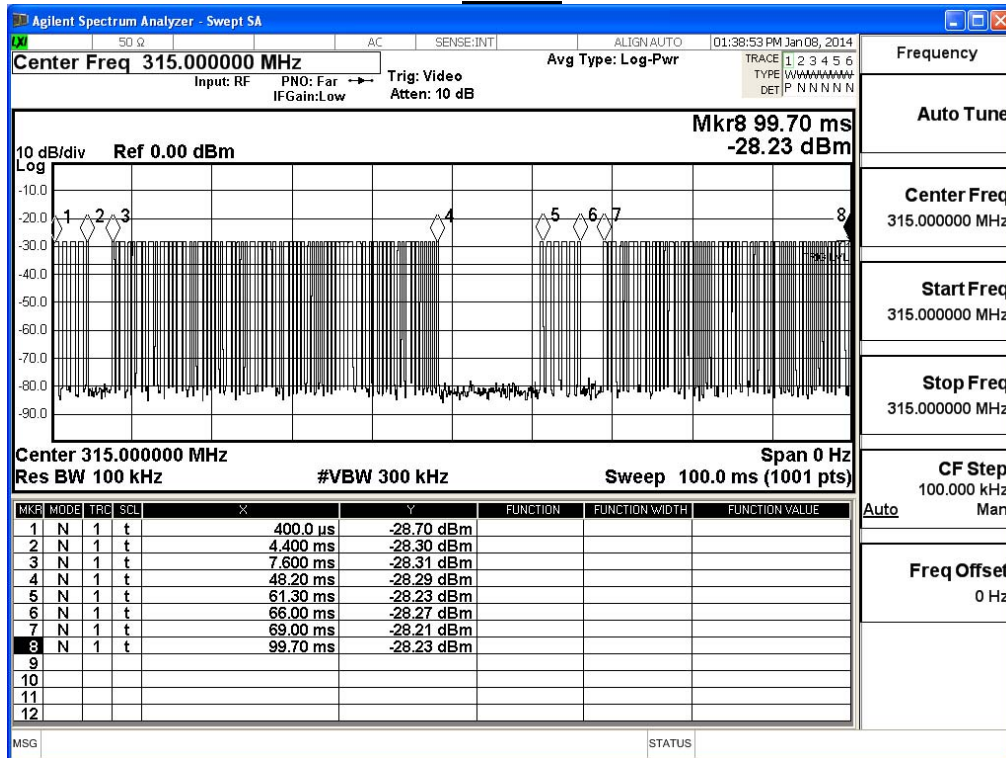

3ms

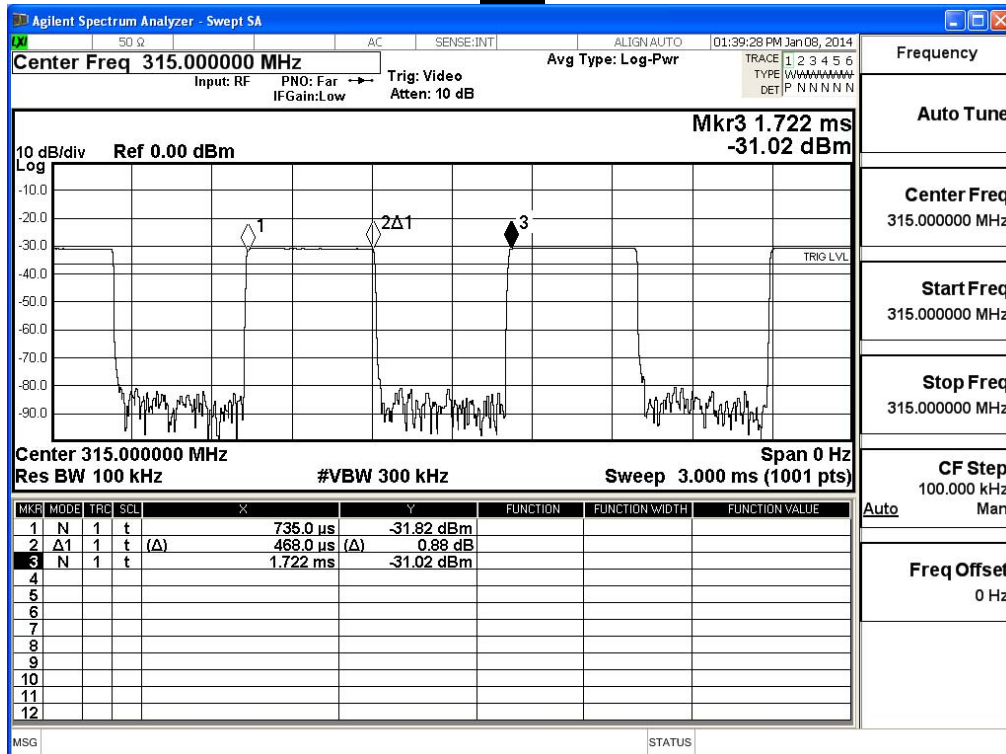

5. Transmitter time

5.1. Test Equipment

The following test equipments are used during the radiated emission tests:

Transmitter time / SR7

Instrument	Manufacturer	Model No.	Serial No	Next Cal. Date
Spectrum Analyzer	Agilent	N9010A-EXA	US47140172	2014/08/05

Note: 1. All equipments that need to calibrate are with calibration period of 1 year.

5.2. Test Setup

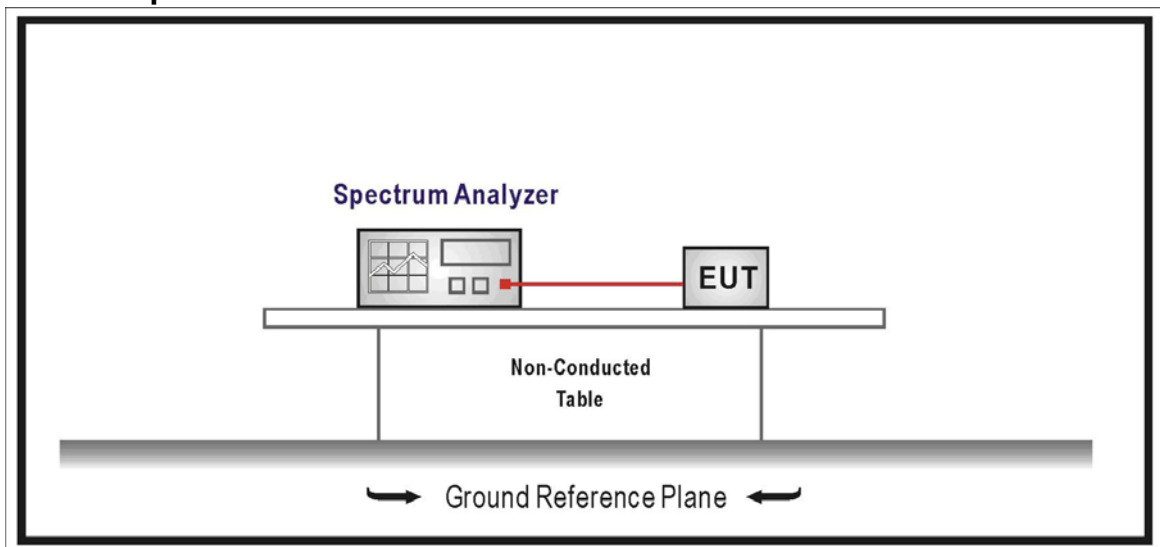

5.3. Limits

The duration of each transmission shall not be greater than one second and the silent period between transmissions shall be at least 30 times the duration of the transmission but in no case less than 10 seconds.

5.4. Test Specification

According to FCC Part 15 Subpart C Paragraph 15.231(b): 2012

5.5. Uncertainty

± 25msec

5.6. Test Result

Product	REMOTE CONTROLLER		
Test Item	Transmitter time		
Test Mode	Mode 1: Transmit		
Date of Test	2014/01/15	Test Site	SR7

Center Frequency	315 MHz
Transmitter time = 0.894s < 5 sec.	Below 5 sec.
Result	PASS

