

FCC TEST REPORT

47 CFR FCC Part 15 Subpart B

Report Reference No.....:	MWR1403002904	
FCC ID.....:	2ABOSSKYCOOL	
Compiled by (position+printed name+signature)...	File administrators Martin Ao	
Supervised by (position+printed name+signature)...	Test Engineer Martin Ao	
Approved by (position+printed name+signature)...	Manager Dixon Hao	
Date of issue.....:	Mar 25, 2014	
Representative Laboratory Name ..:	Maxwell International Co., Ltd.	
Address	Room 509, Hongfa center building, Baoan District, Shenzhen, Guangdong, China	
Testing Laboratory Name	DTT Services Co.,Ltd	
Address	1F,2 Block, Jiaquan Building, Guanlan High-tech Park, Bao'an District, Shenzhen, Guangdong, China. 518110	
Applicant's name.....:	SKY PHONE LLC	
Address	1348 Washington Av. Suite 350	
Test specification		
Standard	47 CFR FCC Part 15 Subpart B - Unintentional Radiators	
	ANSI C63.4: 2009	
TRF Originator.....:	DTT Services Co.,Ltd	
Master TRF.....:	Dated 2011-05	
DTT Services Co.,Ltd All rights reserved.		
This publication may be reproduced in whole or in part for non-commercial purposes as long as the DTT Services Co.,Ltd as copyright owner and source of the material. DTT Services Co.,Ltd takes no responsibility for and will not assume liability for damages resulting from the reader's interpretation of the reproduced material due to its placement and context.		
Test item description	Sky Cool	
Trade Mark		
Model/Type reference.....:	MG834	
Listed Models	MG834xy(x:0-9,y:A-Z),MS834,MS834xy(x:0-9,y:A-Z), PRO8340xy(x:0-9,y:A-Z), W100	
Manufacturer.....:	SKY PHONE LLC	
Rating	DC 3.70V	
Hardware version	M152-MB-V5.1	
Software version	V5.1	
Result.....:	PASS	

TEST REPORT

Test Report No. :	MWR1403002904	Mar 25, 2014
		Date of issue

Equipment under Test : Sky Cool

Model /Type : MG834

Listed Models : MG834xy(x:0-9,y:A-Z),MS834,MS834xy(x:0-9,y:A-Z),
PRO8340xy(x:0-9,y:A-Z), W100

Applicant : **SKY PHONE LLC**

Address : 1348 Washington Av. Suite 350

Manufacturer : **SKY PHONE LLC**

Address : 1348 Washington Av. Suite 350

Test Result:	PASS
---------------------	-------------

The test report merely corresponds to the test sample.
It is not permitted to copy extracts of these test result without the written permission of the test laboratory.

Contents

1.	<u>TEST STANDARDS.....</u>	4
2.	<u>SUMMARY</u>	5
2.1.	General Remarks	5
2.2.	Product Description	5
2.3.	Equipment Under Test	5
2.4.	Short description of the Equipment under Test (EUT)	5
2.5.	EUT operation mode	5
2.6.	Related Submittal(s) / Grant (s)	5
2.7.	Internal Identification of AE used during the test	6
2.8.	Modifications	6
2.9.	EUT configuration	6
2.10.	Configuration of Tested System	6
2.11.	NOTE	7
3.	<u>TEST ENVIRONMENT.....</u>	8
3.1.	Address of the test laboratory	8
3.2.	Test Facility	8
3.3.	Environmental conditions	8
3.4.	Statement of the measurement uncertainty	8
3.5.	Equipments Used during the Test	9
4.	<u>TEST CONDITIONS AND RESULTS.....</u>	10
4.1.	Conducted Emissions Test	10
4.2.	Radiated Emission Test	12
5.	<u>TEST SETUP PHOTOS OF THE EUT</u>	16
6.	<u>EXTERNAL AND INTERNAL PHOTOS OF THE EUT</u>	17

1. TEST STANDARDS

The tests were performed according to following standards:

[47 CFR FCC Part 15 Subpart B](#) - Unintentional Radiators

[ANSI C63.4: 2009](#) – American National Standard for Methods of Measurement of Radio-Noise Emissions from Low-Voltage Electrical and Electronic Equipment in the Range of 9 kHz to 40GHz

2. SUMMARY

2.1. General Remarks

Date of receipt of test sample	:	Mar 10, 2014
Testing commenced on	:	Mar 10, 2014
Testing concluded on	:	Mar 24, 2014

2.2. Product Description

The **SKY PHONE LLC**'s Model: MG384 or the "EUT" as referred to in this report; more general information as follows, for more details, refer to the user's manual of the EUT.

Name of EUT	Sky Cool
Model Number	MG834, MG834xy(x:0-9,y:A-Z),MS834,MS834xy(x:0-9,y:A-Z), PRO8340xy(x:0-9,y:A-Z), W100
FCC ID	2ABOSSKYCOOL
Modulation Type	GMSK for GSM/GPRS
Antenna Type	External
GSM/EDGE/GPRS	Supported GPRS
Extreme temp. Tolerance	-30°C to +50°C
Extreme vol. Limits	3.40VDC to 4.20VDC (nominal: 3.70VDC)
GSM Operation Frequency Band	GSM 850MHz/ PCS 1900MHz
GSM Release Version	R99
GPRS operation mode	Class B
GPRS Multislot Class	12
EGPRS Multislot Class	Not Supported

2.3. Equipment under Test

Power supply system utilised

Power supply voltage	:	<input type="radio"/> 120V / 60 Hz	<input type="radio"/> 115V / 60Hz
		<input type="radio"/> 12 V DC	<input type="radio"/> 24 V DC
		<input checked="" type="radio"/> Other (specified in blank below)	

DC 3.70V

2.4. Short description of the Equipment under Test (EUT)

2.4GHz (SKY COOL (M/N: MG834))

For more details, refer to the user's manual of the EUT.

2.5. EUT operation mode

The EUT has been tested under typical operating condition.

2.6. Related Submittal(s) / Grant (s)

This submittal(s) (test report) is intended for FCC ID: **2ABOSSKYCOOL** filing to comply with the FCC Part 15, Subpart B Rules.

2.7. Internal Identification of AE used during the test

AE ID*	Description
AE1	Battery
AE2	Charger

AE1

Model: MG834
 Manufacturer: SKY PHONE LLC
 Capacitance: 800mAh
 Nominal Voltage: 3.70V

AE2:

Model: MG834
 Manufacturer: SKY PHONE LLC

*AE ID: is used to identify the test sample in the lab internally.
 We not used AE2 when for FCC Part 15B test.

2.8. Modifications

No modifications were implemented to meet testing criteria.

2.9. EUT configuration

The following peripheral devices and interface cables were connected during the measurement:

- - supplied by the manufacturer
- - supplied by the lab

○	Power Cable	Length (m) :	/
		Shield :	/
		Detachable :	/
○	Multimeter	Manufacturer :	/
		Model No. :	/

2.10. Configuration of Tested System

Configuration of Tested System

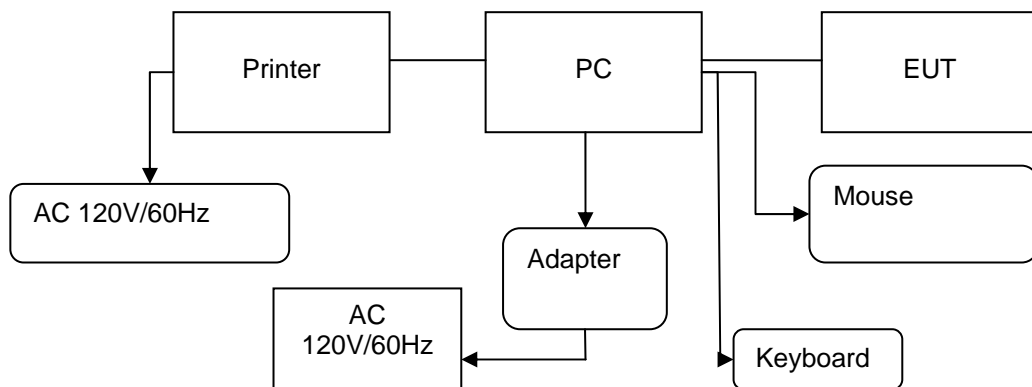

Equipment Used in Tested System

No.	Equipment	Manufacturer	Model No.	Serial No.	Length	shielded/unshielded	Notes
1	PC	Acer	E1-571G	1RNN42X	/	/	DOC
2	Printer	HP	C3990	C3990A	/	/	DOC
3	Mouse	DELL	MO56UO A	G0E02SY7	1.00m	unshielded	DOC
4	Keyboard	DELL	L100	CNRH656658907	/	/	DOC

				26009L			
5	USB Cable (EUT to PC)	Genshuo	USB 2.0	N/A	0.60m	unshielded	N/A
6	USB Cable (Printer to PC)	Genshuo	USB 2.0	N/A	1.20m	unshielded	N/A
7	Power line	/	/	N/A	1.00m	unshielded	N/A
8	Adapter	HIPRO	HP-A0904A3	F1120709016S404	1.50m	unshielded	DOC

2.11. NOTE

1. The EUT is a Sky Cool with GSM/GPRS,WiFi and Bluetooth fuction,The functions of the EUT listed as below:

	Test Standards	Reference Report
GSM/GPRS	FCC Part 22/FCC Part 24	MWR1403002901
Bluetooth	FCC Part 15 C 15.247	MWR1403002902
WiFi	FCC Part 15 C 15.247	MWR1403002903
USB Port	FCC Part 15 B	MWR1403002904
SAR	FCC Part 2 §2.1093	MWR1403002905

3. TEST ENVIRONMENT

3.1. Address of the test laboratory

DTT Services Co.,Ltd

1F,2 Block, Jiaquan Building, Guanlan High-tech Park, Bao'an District, Shenzhen, Guangdong, China.
518110

The sites are constructed in conformance with the requirements of ANSI C63.7, ANSI C63.4 (2003) and CISPR Publication 22.

3.2. Test Facility

The test facility is recognized, certified, or accredited by the following organizations:

IC Registration No.: 9783A

The 3m alternate test site of DTT Services Co.,Ltd EMC Laboratory has been registered by Certification and Engineer Bureau of Industry Canada for the performance of with Registration NO.: 9783A on Aug, 2011.

FCC-Registration No.: 214666

DTT Services Co.,Ltd EMC Laboratory has been registered and fully described in a report filed with the (FCC) Federal Communications Commission. The acceptance letter from the FCC is maintained in our files. Registration 214666, Sep 19, 2011

3.3. Environmental conditions

During the measurement the environmental conditions were within the listed ranges:

Temperature:	<u>15-35 ° C</u>
Humidity:	<u>30-60 %</u>
Atmospheric pressure:	<u>950-1050mbar</u>

3.4. Statement of the measurement uncertainty

The data and results referenced in this document are true and accurate. The reader is cautioned that there may be errors within the calibration limits of the equipment and facilities. The measurement uncertainty was calculated for all measurements listed in this test report acc. to CISPR 16 - 4 „Specification for radio disturbance and immunity measuring apparatus and methods – Part 4: Uncertainty in EMC Measurements“ and is documented in the DTT Services Co.,Ltd quality system acc. to DIN EN ISO/IEC 17025. Furthermore, component and process variability of devices similar to that tested may result in additional deviation. The manufacturer has the sole responsibility of continued compliance of the device.

Hereafter the best measurement capability for DTT Services Co.,Ltd laboratory is reported:

Test	Range	Measurement Uncertainty	Notes
Radiated Emission	30~1000MHz	4.24 dB	(1)
Radiated Emission	1~18GHz	5.16 dB	(1)
Radiated Emission	18-40GHz	5.54 dB	(1)
Conducted Disturbance	0.15~30MHz	3.39 dB	(1)

(1) This uncertainty represents an expanded uncertainty expressed at approximately the 95% confidence level using a coverage factor of k=2.

3.5. Equipments Used during the Test

Conducted Emission					
Item	Test Equipment	Manufacturer	Model No.	Serial No.	Last Cal.
1	EMI TEST RECEIVER	Rohde & Schwarz	ESCI	100106	2013/10/26
2	ARTIFICIAL MAINS	Rohde & Schwarz	ESH2-Z5	100028	2013/10/26
3	PULSE LIMITER	Rohde & Schwarz	ESHSZ2	100044	2013/10/26
4	EMI TEST Software	Rohde & Schwarz	ES-K1	N/A	N/A

Radiated Emission					
Item	Test Equipment	Manufacturer	Model No.	Serial No.	Last Cal.
1	Ultra-Broadband Antenna	ShwarzBeck	VULB9163	538	2013/10/27
2	EMI TEST RECEIVER	Rohde & Schwarz	ESI 26	100009	2013/10/25
3	EMI TEST Software	Audix	E3	N/A	N/A
4	TURNTABLE	MATURO	TT2.0	----	N/A
5	ANTENNA MAST	MATURO	TAM-4.0-P	----	N/A
6	EMI TEST Software	Rohde & Schwarz	ESK1	N/A	N/A
7	HORN ANTENNA	ShwarzBeck	9120D	1012	2013/10/27
8	Preamplifier	ShwarzBeck	BBV 9718	BBV 9718	2013/10/25
9	Broadband Preamplifier	ShwarzBeck	BBV743	9743-0079	2013/10/25

The calibration interval was one year.

4. TEST CONDITIONS AND RESULTS

4.1. Conducted Emissions Test

TEST CONFIGURATION

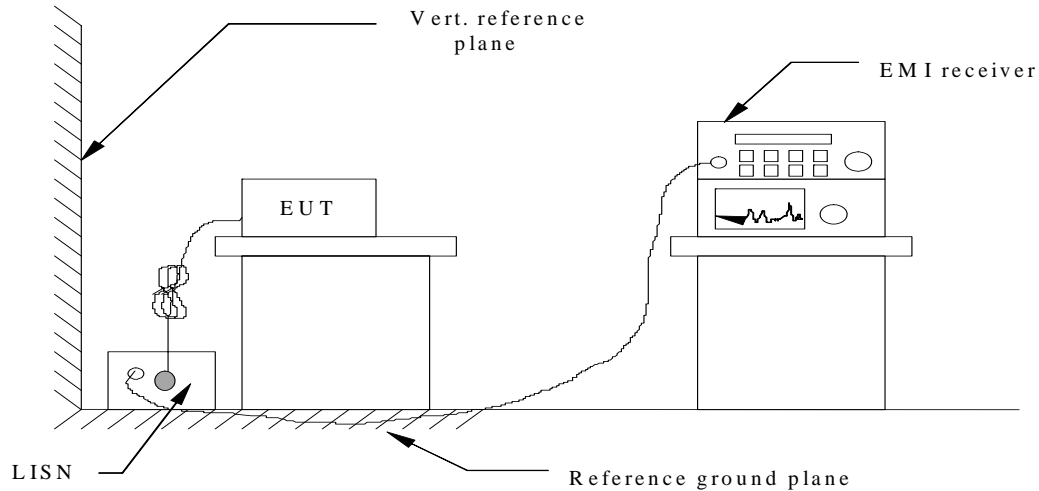

TEST PROCEDURE

1. The equipment was set up as per the test configuration to simulate typical actual usage per the user's manual. The EUT is a tabletop system; a wooden table with a height of 0.8 meters is used and is placed on the ground plane as per ANSI C63.4-2009.
2. Support equipment, if needed, was placed as per ANSI C63.4-2009.
3. All I/O cables were positioned to simulate typical actual usage as per ANSI C63.4-2009.
4. The EUT received AC120V/60Hz power through a Line Impedance Stabilization Network (LISN) which supplied power source and was grounded to the ground plane.
5. All support equipments received AC power from a second LISN, if any.
6. The EUT test program was started. Emissions were measured on each current carrying line of the EUT using a spectrum Analyzer / Receiver connected to the LISN powering the EUT. The LISN has two monitoring points: Line 1 (Hot Side) and Line 2 (Neutral Side). Two scans were taken: one with Line 1 connected to Analyzer / Receiver and Line 2 connected to a 50 ohm load; the second scan had Line 1 connected to a 50 ohm load and Line 2 connected to the Analyzer / Receiver.
7. Analyzer / Receiver scanned from 150 KHz to 30MHz for emissions in each of the test modes.
8. During the above scans, the emissions were maximized by cable manipulation.

CONDUCTED POWER LINE EMISSION LIMIT

For unintentional device, according to § 15.107(a) Line Conducted Emission Limits is as following :

Frequency (MHz)	Maximum RF Line Voltage (dBµV)			
	CLASS A		CLASS B	
	Q.P.	Ave.	Q.P.	Ave.
0.15 - 0.50	79	66	66-56*	56-46*
0.50 - 5.00	73	60	56	46
5.00 - 30.0	73	60	60	50

* Decreasing linearly with the logarithm of the frequency

TEST RESULTS

SCAN TABLE: "Voltage (150K-30M) FIN"
 Short Description: 150K-30M Voltage

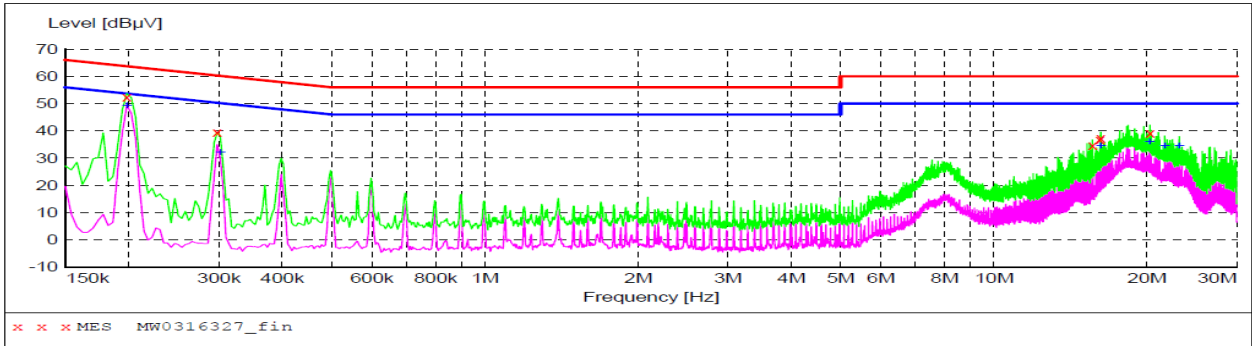

MEASUREMENT RESULT: "MW0316327_fin"

3/16/2014 5:47PM

Frequency MHz	Level dBuV	Transd dB	Limit dBuV	Margin dB	Detector	Line	PE
0.198000	52.50	10.3	64	11.2	QP	N	GND
0.298000	39.50	10.2	60	20.8	QP	N	GND
15.618000	34.70	10.9	60	25.3	QP	N	GND
16.166000	36.80	10.9	60	23.2	QP	N	GND
16.230000	37.30	10.9	60	22.7	QP	N	GND
20.258000	39.20	10.9	60	20.8	QP	N	GND

MEASUREMENT RESULT: "MW0316327_fin2"

3/16/2014 5:47PM

Frequency MHz	Level dBuV	Transd dB	Limit dBuV	Margin dB	Detector	Line	PE
0.198000	49.10	10.3	54	4.6	AV	N	GND
0.302000	31.90	10.2	50	18.3	AV	N	GND
16.230000	34.30	10.9	50	15.7	AV	N	GND
20.258000	35.90	10.9	50	14.1	AV	N	GND
21.662000	34.50	11.0	50	15.5	AV	N	GND
23.130000	34.30	11.1	50	15.7	AV	N	GND

SCAN TABLE: "Voltage (150K-30M) FIN"
 Short Description: 150K-30M Voltage

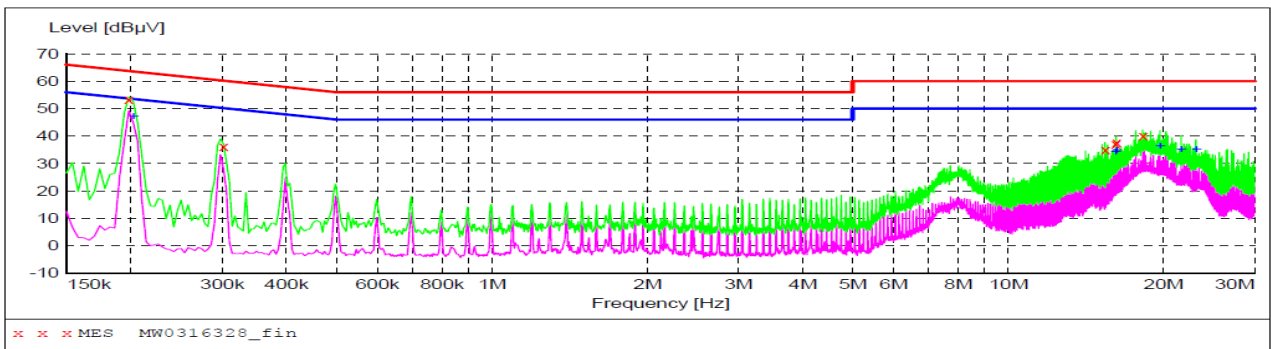

MEASUREMENT RESULT: "MW0316328_fin"

3/16/2014 5:51PM

Frequency MHz	Level dBuV	Transd dB	Limit dBuV	Margin dB	Detector	Line	PE
0.198000	53.30	10.3	64	10.4	QP	L1	GND
0.302000	36.20	10.2	60	24.0	QP	L1	GND
15.434000	35.00	10.9	60	25.0	QP	L1	GND
16.166000	37.00	10.9	60	23.0	QP	L1	GND
16.230000	37.60	10.9	60	22.4	QP	L1	GND
18.242000	40.20	10.9	60	19.8	QP	L1	GND

MEASUREMENT RESULT: "MW0316328_fin2"

3/16/2014 5:51PM

Frequency MHz	Level dBuV	Transd dB	Limit dBuV	Margin dB	Detector	Line	PE
0.202000	47.00	10.3	54	6.5	AV	L1	GND
16.166000	34.10	10.9	50	15.9	AV	L1	GND
16.230000	34.60	10.9	50	15.4	AV	L1	GND
19.710000	36.30	10.9	50	13.7	AV	L1	GND
21.662000	35.00	11.0	50	15.0	AV	L1	GND
23.130000	35.00	11.1	50	15.0	AV	L1	GND

4.2. Radiated Emission Test

TEST CONFIGURATION

- a) Radiated Emission Test Set-Up, Frequency below 1000MHz

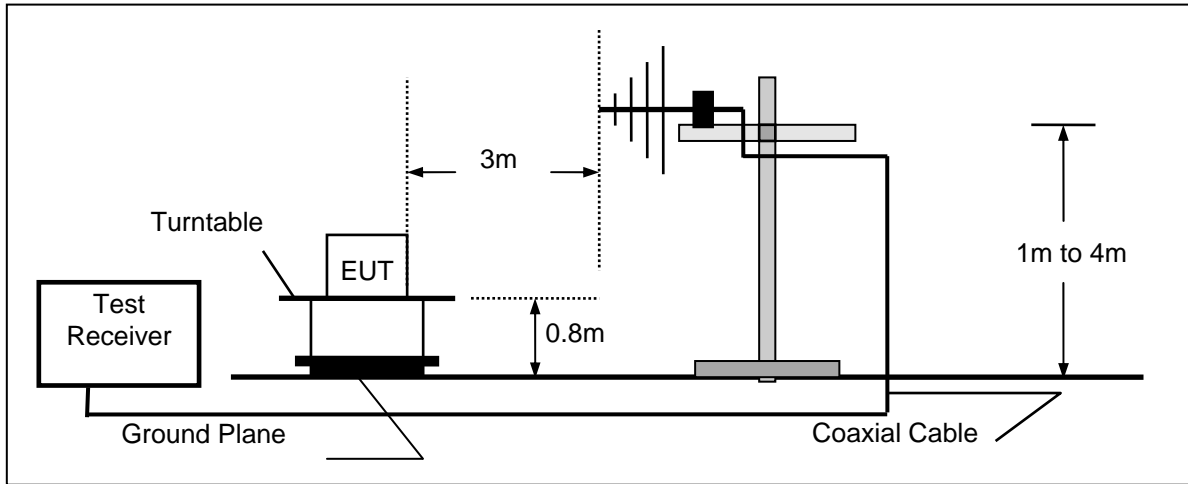

- b) Radiated Emission Test Set-Up, Frequency above 1000MHz

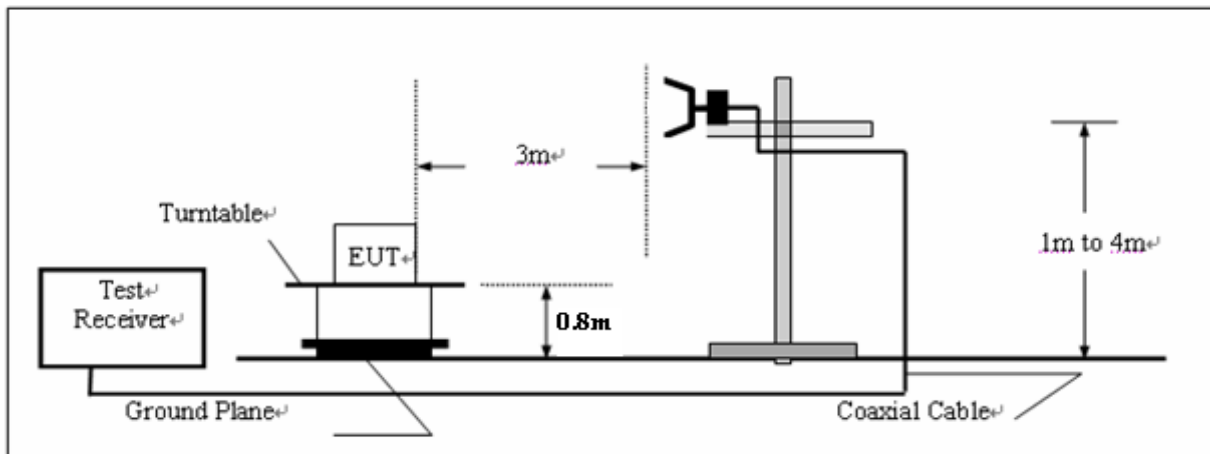

TEST PROCEDURE

1. The EUT is placed on a turntable, which is 0.8m above ground plane.
2. The turntable shall be rotated for 360 degrees to determine the position of maximum emission level.
3. EUT is set 3m away from the receiving antenna, which is varied from 1m to 4m to find out the highest emissions.
4. Maximum procedure was performed on the six highest emissions to ensure EUT compliance.
5. And also, each emission was to be maximized by changing the polarization of receiving antenna both horizontal and vertical.
6. Repeat above procedures until the measurements for all frequencies are complete.
7. The maximum operation frequency was 512MHz, the radiated emission test frequency from 30MHz to 6GHz.

FIELD STRENGTH CALCULATION

The field strength is calculated by adding the Antenna Factor and Cable Factor and subtracting the Amplifier Gain and Duty Cycle Correction Factor (if any) from the measured reading. The basic equation with a sample calculation is as follows:

$$FS = RA + AF + CL - AG$$

Where FS = Field Strength	CL = Cable Attenuation Factor (Cable Loss)
RA = Reading Amplitude	AG = Amplifier Gain
AF = Antenna Factor	

For example

Frequency (MHz)	FS (dBµV/m)	RA (dBµV/m)	AF (dB)	CL (dB)	AG (dB)	Transd (dB)
300.00	40	58.1	12.2	1.6	31.90	-18.1

Transd=AF +CL-AG

RADIATION LIMIT

For unintentional device, according to § 15.109(a), except for Class A digital devices, the field strength of radiated emissions from unintentional radiators at a distance of 3 meters shall not exceed the following values:

Frequency (MHz)	Distance (Meters)	Radiated (dBµV/m)	Radiated (µV/m)
30-88	3	40.0	100
88-216	3	43.5	150
216-960	3	46.0	200
Above 960	3	54.0	500

TEST RESULTS

For 30MHz-1GHz

SCAN TABLE: "test Field(30M-1G)OP"

Short Description: Field Strength(30M-1G)
 Start Stop Step Detector Meas. IF Transducer
 Frequency Frequency Width Time Bandw.
 30.0 MHz 1.0 GHz 60.0 kHz QuasiPeak 1.0 s 120 kHz VULB9163

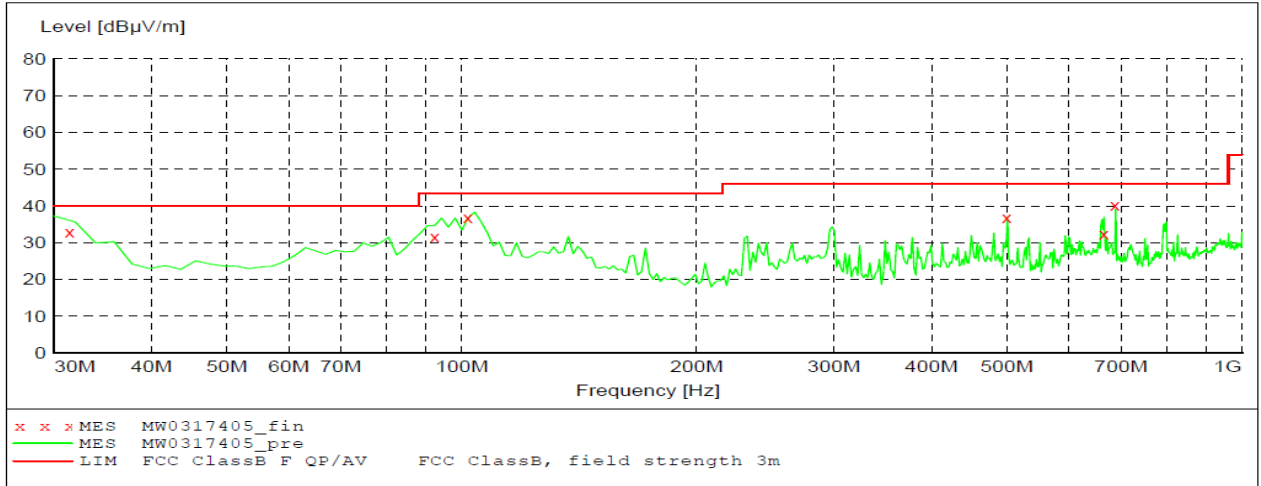

MEASUREMENT RESULT: "MW0317405_fin"

3/18/2014 00:11AM

Frequency MHz	Level dBuV/m	Transd dB	Limit dBuV/m	Margin dB	Det.	Height cm	Azimuth deg	Polarization
31.440000	33.00	-10.9	40.0	7.0	QP	100.0	196.00	VERTICAL
92.340000	31.70	-20.5	43.5	11.8	QP	114.0	225.00	VERTICAL
101.880000	36.70	-19.6	43.5	6.8	QP	100.0	218.00	VERTICAL
499.980000	36.80	-14.3	46.0	9.2	QP	100.0	280.00	VERTICAL
665.460000	32.40	-11.1	46.0	13.6	QP	100.0	235.00	VERTICAL
688.080000	40.10	-10.9	46.0	5.9	QP	124.0	168.00	VERTICAL

SCAN TABLE: "test Field(30M-1G)OP"

Short Description: Field Strength(30M-1G)
 Start Stop Step Detector Meas. IF Transducer
 Frequency Frequency Width Time Bandw.
 30.0 MHz 1.0 GHz 60.0 kHz QuasiPeak 1.0 s 120 kHz VULB9163

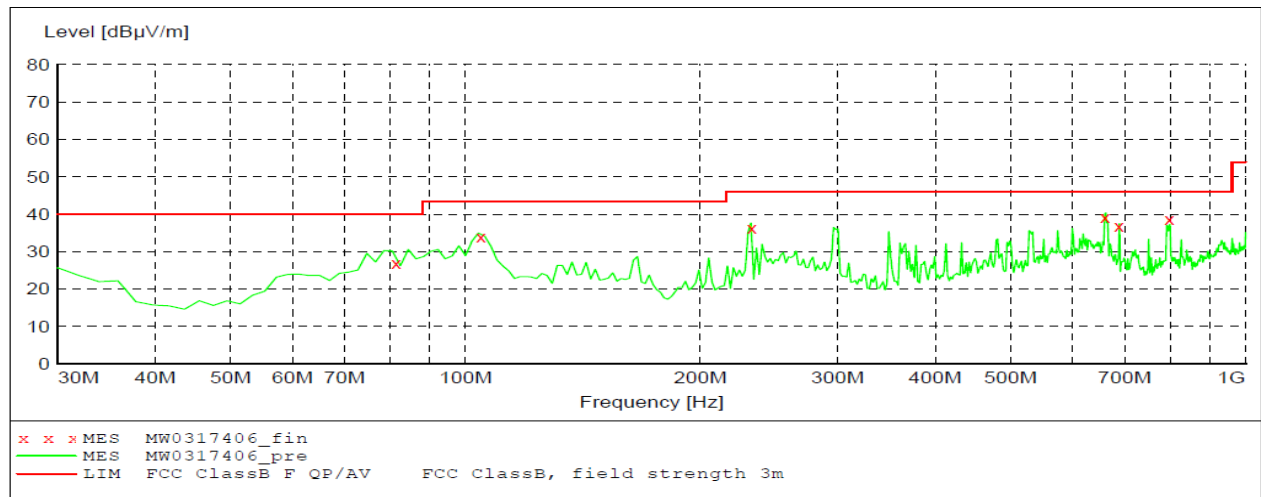

MEASUREMENT RESULT: "MW0317406_fin"

3/18/2014 00:21AM

Frequency MHz	Level dBuV/m	Transd dB	Limit dBuV/m	Margin dB	Det.	Height cm	Azimuth deg	Polarization
81.480000	26.90	-22.4	40.0	13.1	QP	327.0	188.00	HORIZONTAL
104.700000	34.10	-19.3	43.5	9.4	QP	251.0	183.00	HORIZONTAL
232.920000	36.20	-20.4	46.0	9.8	QP	100.0	264.00	HORIZONTAL
660.360000	39.30	-11.0	46.0	6.7	QP	147.0	152.00	HORIZONTAL
688.080000	36.90	-10.9	46.0	9.1	QP	100.0	163.00	HORIZONTAL
798.900000	38.60	-8.8	46.0	7.4	QP	118.0	179.00	HORIZONTAL

For 1GHz-7.5GHz

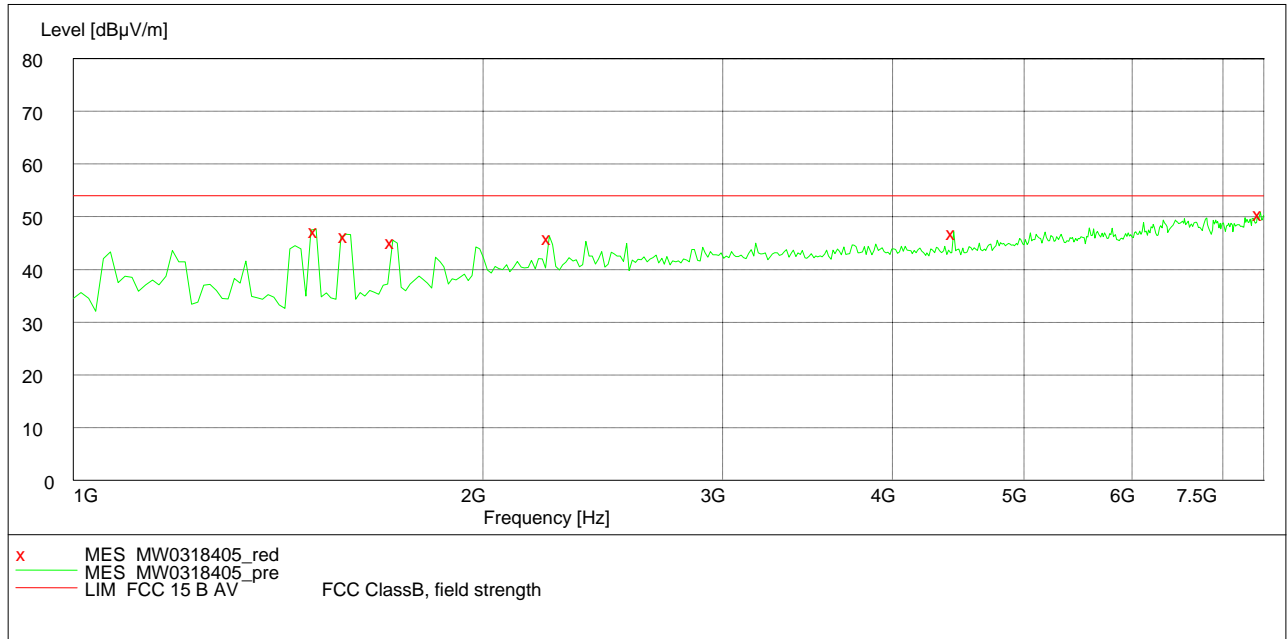

Frequency MHz	Level dBµV/m	Transd dB	Limit dBµV/m	Margin dB	Det.	Height cm	Azimuth deg	Polarization
1508.016032	47.60	-5.9	53.90	6.3	Peak	100.0	181.00	HORIZONTAL
1586.172345	46.70	-5.1	53.90	7.2	Peak	100.0	254.00	HORIZONTAL
1716.432866	45.50	-3.8	53.90	8.4	Peak	100.0	220.00	HORIZONTAL
2237.474950	46.30	-0.3	53.90	7.6	Peak	100.0	347.00	HORIZONTAL
4438.877756	47.20	3.4	53.90	6.7	Peak	100.0	293.00	HORIZONTAL
7460.921844	50.80	11.3	53.90	3.1	Peak	100.0	308.00	HORIZONTAL

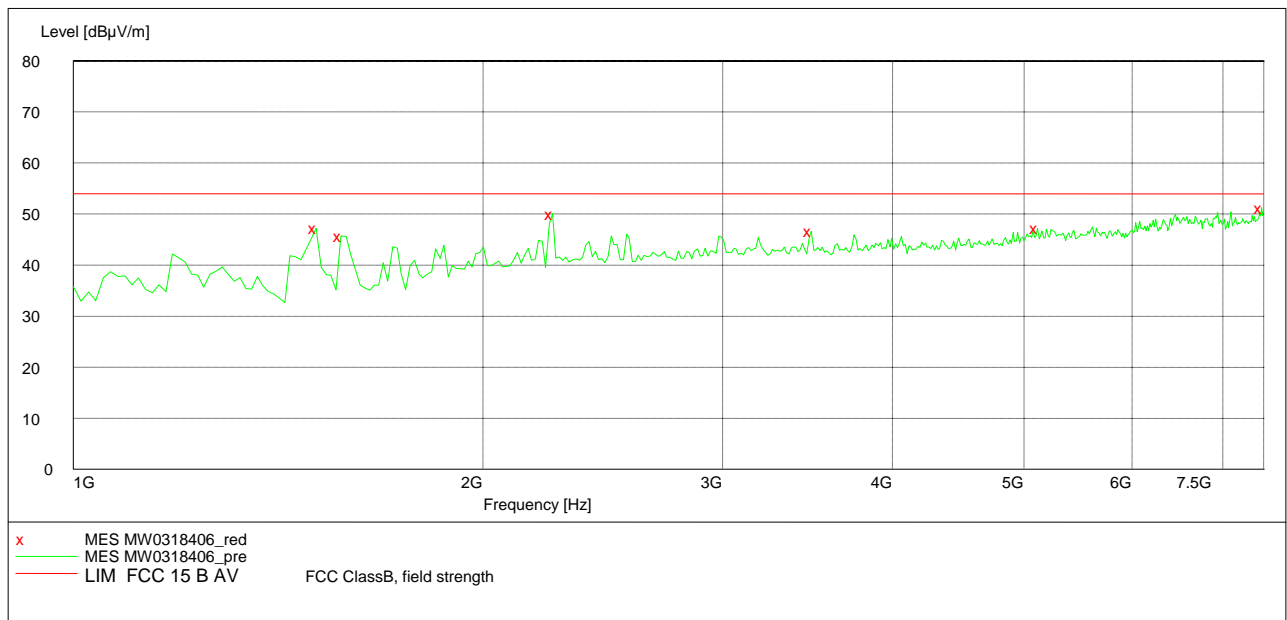

Frequency MHz	Level dBµV/m	Transd dB	Limit dBµV/m	Margin dB	Det.	Height cm	Azimuth deg	Polarization
1508.016032	47.20	-5.9	53.90	6.7	Peak	100.0	14.00	VERTICAL
1573.146293	45.70	-5.2	53.90	8.2	Peak	100.0	271.00	VERTICAL
2250.501002	50.10	-0.2	53.90	3.8	Peak	100.0	329.00	VERTICAL
3487.975952	46.60	2.6	53.90	7.3	Peak	100.0	345.00	VERTICAL
5116.232465	47.20	5.8	53.90	6.7	Peak	100.0	236.00	VERTICAL
7473.947896	51.20	11.4	53.90	2.7	Peak	100.0	310.00	VERTICAL

5. Test Setup Photos of the EUT

Conducted Emission (AC Mains)



Radiated Emission (30MHz-1GHz)

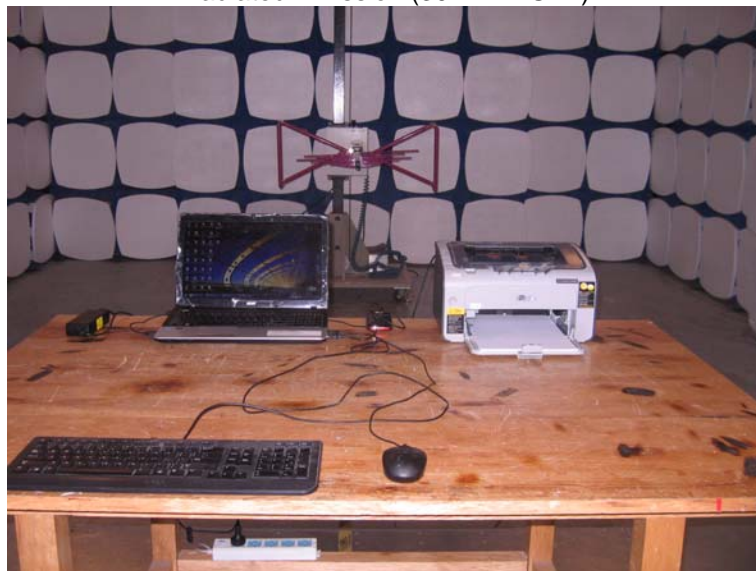

Radiated Emission (above 1GHz)



6. External and Internal Photos of the EUT

External photos of the EUT









Internal photos of the EUT

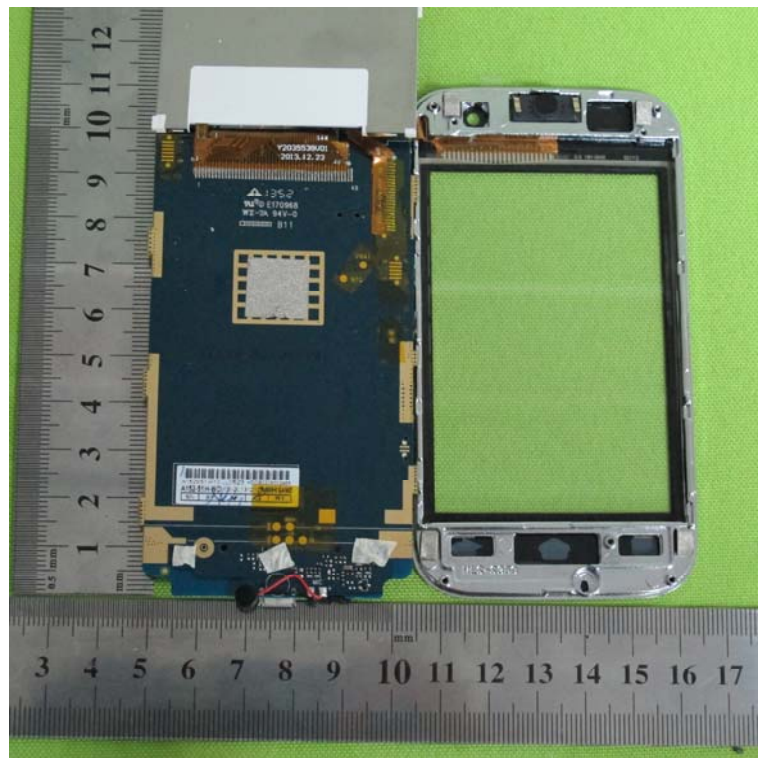
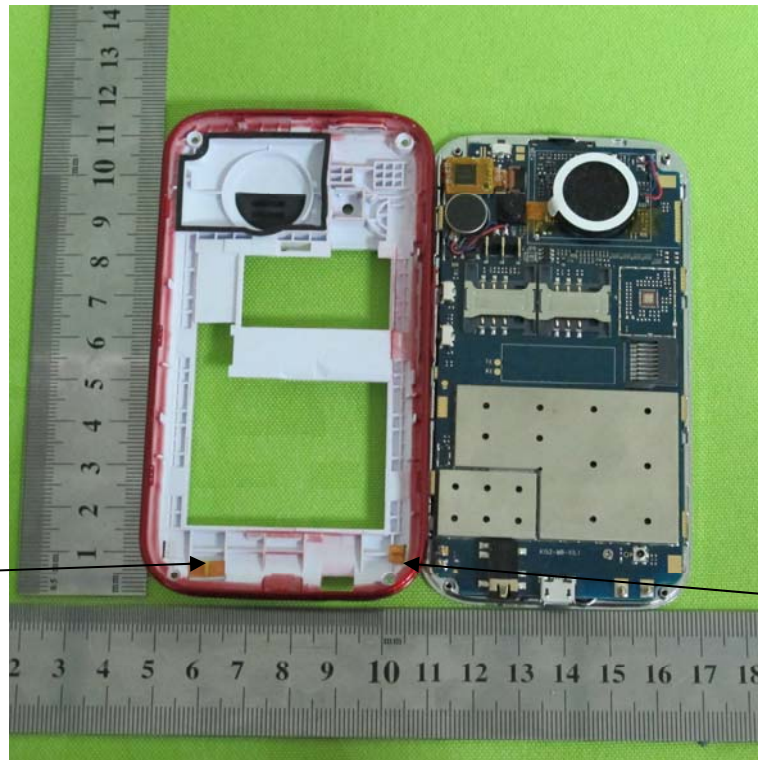

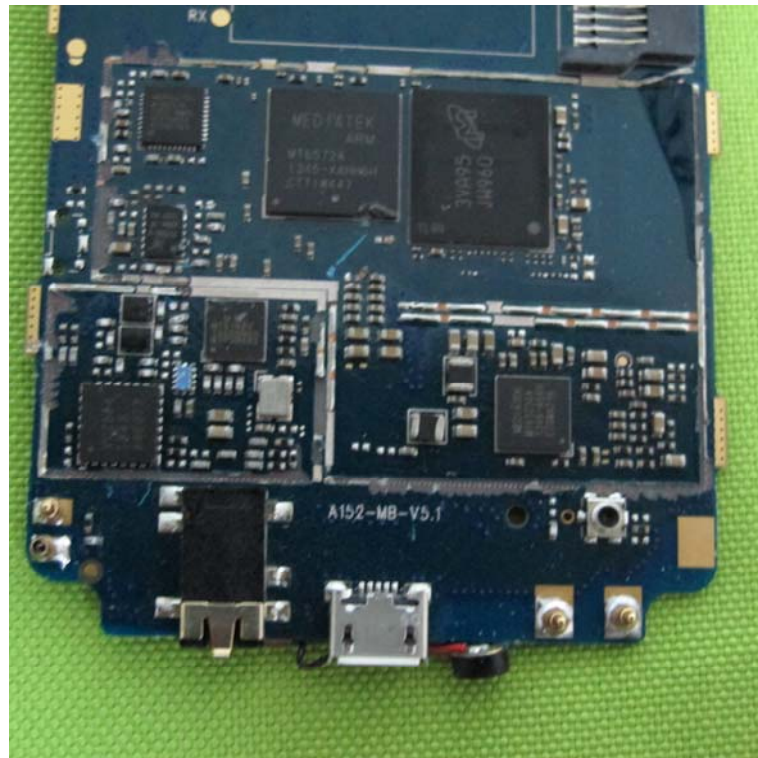
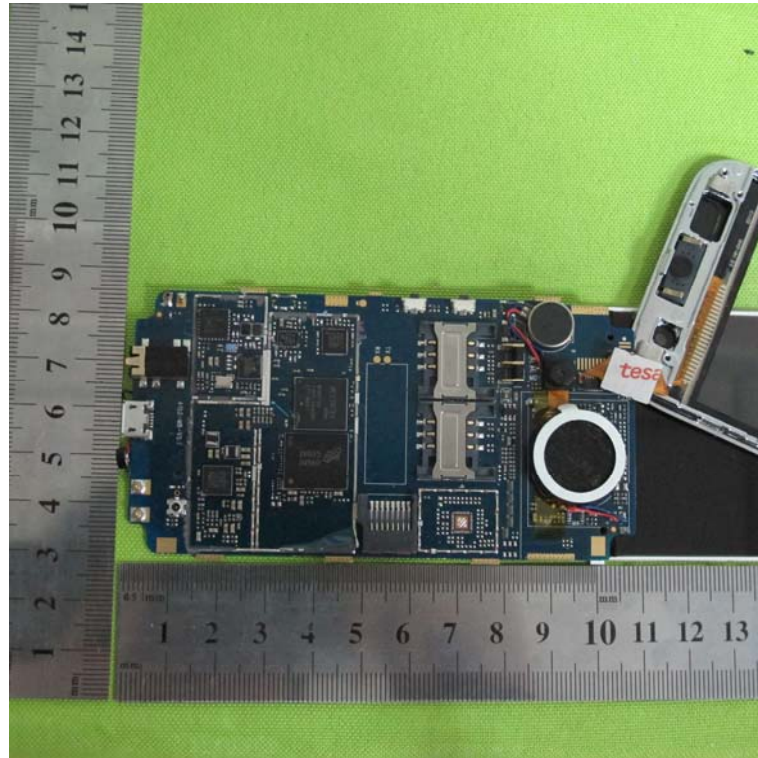

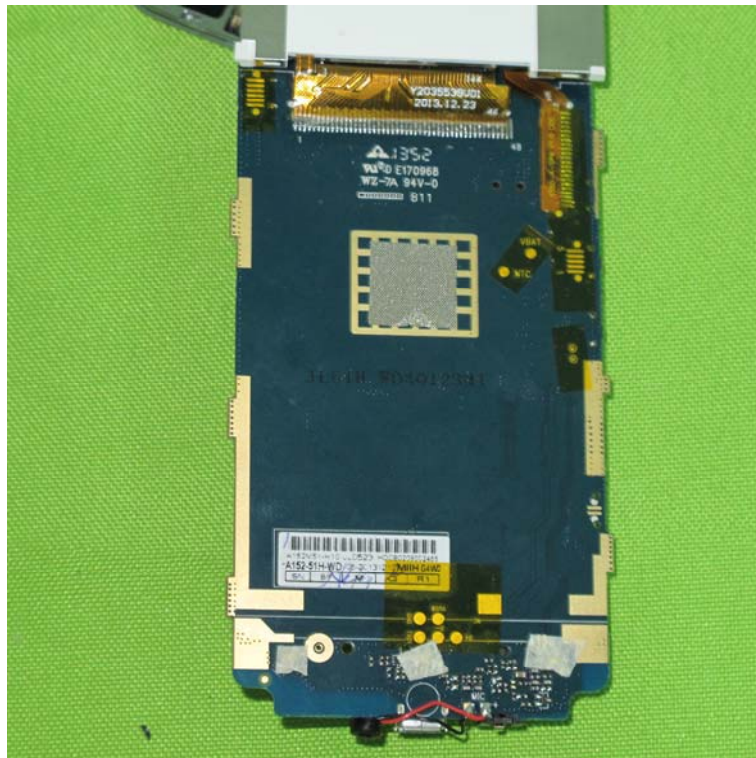
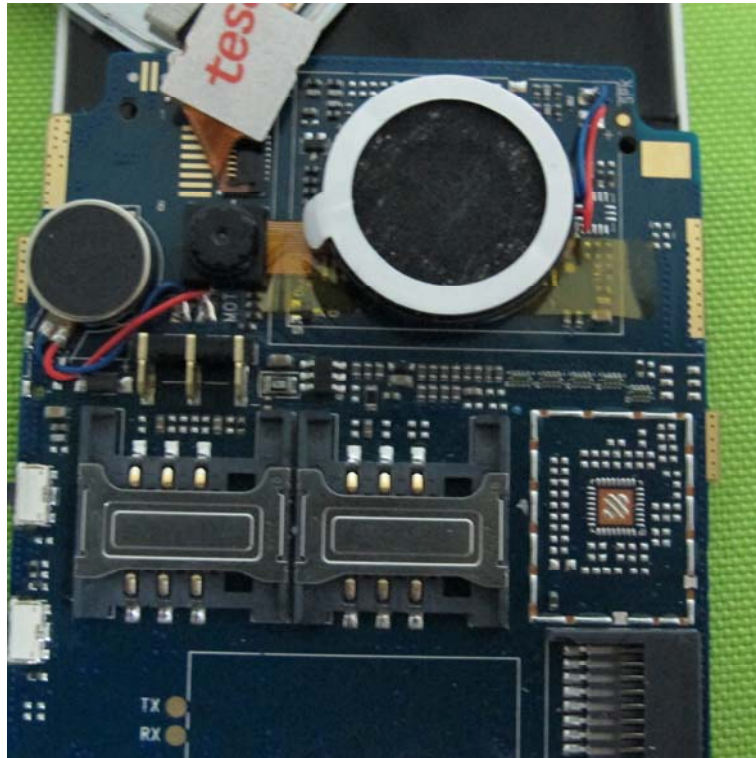

.....End of Report.....