



FCC Test Report

FCC ID:2ABNJ-LV580

Product: Bluetooth Speaker
Trade Name:  不見不散
SEE ME HERE
深圳西乡通富工业
Model Number: LV580
Serial Model: N/A
Report No.: NTEK-2016NT07056964F1

Prepared for
Shenzhen See Me Here Electronic Co., Ltd.
3-4th Floor, Building D, 4th Floor, Building A1, Xixiang Tongfuyu Industrial
Park, Bao'an District, Shenzhen, Guangdong China

Prepared by
Shenzhen NTEK Testing Technology Co., Ltd.
1/F, Building E, Fenda Science Park, Sanwei Community, Xixiang Street,
Bao'an District, Shenzhen P.R. China
Tel.: +86-0755-61156588 Fax.: +86-0755-61156599
Website: www.ntek.org.cn

TEST RESULT CERTIFICATION

Applicant's name : Shenzhen See Me Here Electronic Co., Ltd.
Address : 3-4th Floor, Building D,4th Floor, Building A1,Xixiang Tongfuyu
Industrial Park, Bao'an District, Shenzhen, GuangDong China

Manufacturer's Name : Shenzhen See Me Here Electronic Co., Ltd.
Address : 3-4th Floor, Building D,4th Floor, Building A1,Xixiang Tongfuyu
Industrial Park, Bao'an District, Shenzhen, GuangDong China

Product description

Product name..... : Bluetooth Speaker
Model and/or type reference : LV580
Standards..... : FCC Part15B:01 Oct.2015
ANSI C63.4:2014

This device described above has been tested by NTEK, and the test results show that the equipment under test (EUT) is in compliance with Part 15 of FCC Rules. And it is applicable only to the tested sample identified in the report.

This report shall not be reproduced except in full, without the written approval of NTEK, this document may be altered or revised by NTEK, personnel only, and shall be noted in the revision of the document.

Date of Test..... :
Date (s) of performance of tests..... : 05 Jul. 2016 ~28 Jul. 2016
Date of Issue..... : 28 Jul. 2016
Test Result..... : **Pass**

Testing Engineer : 

(Allen Liu)

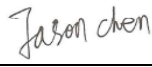
Technical Manager : 

(Jason Chen)

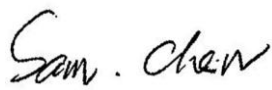
Authorized Signatory : 

(Sam Chen)

Table of Contents	Page
1 . TEST SUMMARY	4
1.1 TEST FACILITY	5
1.2 MEASUREMENT UNCERTAINTY	5
2 . GENERAL INFORMATION	6
2.1 GENERAL DESCRIPTION OF EUT	6
2.2 DESCRIPTION OF TEST SETUP	8
2.3 DESCRIPTION TEST PERIPHERAL AND EUT PERIPHERAL	9
2.4 MEASUREMENT INSTRUMENTS LIST	10
3 . EMC EMISSION TEST	11
3.1 CONDUCTED EMISSION MEASUREMENT	11
3.1.1 POWER LINE CONDUCTED EMISSION	11
3.1.2 TEST PROCEDURE	12
3.1.3 TEST SETUP	12
3.1.4 EUT OPERATING CONDITIONS	12
3.1.5 TEST RESULTS	13
3.2 RADIATED EMISSION MEASUREMENT	17
3.2.1 LIMITS OF RADIATED EMISSION MEASUREMENT	17
3.2.2 TEST PROCEDURE	17
3.2.3 TEST SETUP	18
3.2.4 TEST RESULTS	20
3.2.5 TEST RESULTS(1000~12400MHz)	22
4 . EUT TEST PHOTO	23

1. TEST SUMMARY

Test procedures according to the technical standards:

EMC Emission				
Standard	Test Item	Limit	Judgment	Remark
FCC Part15B:2014 ANSI C63.4: 2014	Conducted Emission	Class B	PASS	
	Radiated Emission	Class B	PASS	

NOTE:

- (1) 'N/A' denotes test is not applicable in this Test Report
- (2) For client's request and manual description, the test will not be executed.

1.1 TEST FACILITY

NTEK Testing Technology Co., Ltd

Add. : 1/F, Building E, Fenda Science Park, Sanwei Community, Xixiang Street, Bao'an District, Shenzhen P.R. China.

FCC Registration Number:238937; IC Registration Number:9270A-1

CNAS Registration Number:L5516

1.2 MEASUREMENT UNCERTAINTY

The reported uncertainty of measurement $y \pm U$, where expanded uncertainty U is based on a standard uncertainty multiplied by a coverage factor of $k=2$, providing a level of confidence of approximately **95** %.

A. Conducted Measurement :

Test Site	Method	Measurement Frequency Range	U, (dB)	NOTE
NTEKC01	ANSI	150 KHz ~ 30MHz	3.2	

B. Radiated Measurement :

Test Site	Method	Measurement Frequency Range	U, (dB)	NOTE
NTEKA01	ANSI	30MHz ~ 1000MHz	4.7	
		1GHz ~12.4GHz	5.0	

2. GENERAL INFORMATION

2.1 GENERAL DESCRIPTION OF EUT

Equipment	Bluetooth Speaker	
Trade Name		
Model Name	LV580	
Serial Model	N/A	
Model Difference	N/A	
Product Description	The EUT is a Bluetooth Speaker.	
	Connecting I/O port:	USB, DC in
	Operation Frequency:	BT:2402~2480 MHz
	Modulation Type:	BT(1Mbps): GFSK BT EDR(2Mbps): π /4-DQPSK
Power Source	DC Voltage	
Adapter	N/A	
Battery	DC 3.7V, 1000mAh	

2.1.1 DESCRIPTION OF TEST MODES

To investigate the maximum EMI emission characteristics generates from EUT, the test system was pre-scanning tested base on the consideration of following EUT operation mode or test configuration mode which possible have effect on EMI emission level. Each of these EUT operation mode(s) or test configuration mode(s) mentioned above was evaluated respectively.

Pretest Mode	Description
Mode 1	Connect to PC
Mode 2	TF card Play

For Conducted Test	
Final Test Mode	Description
Mode 1	Connect to PC
Mode 2	TF card Play

For Radiated Test	
Final Test Mode	Description
Mode 1	Connect to PC
Mode 2	TF card Play

Note: Final Test Mode: Through Pre-scan, find the mode 1 is the worst case. Only the worst case mode is recorded in the report.

2.2 DESCRIPTION OF TEST SETUP

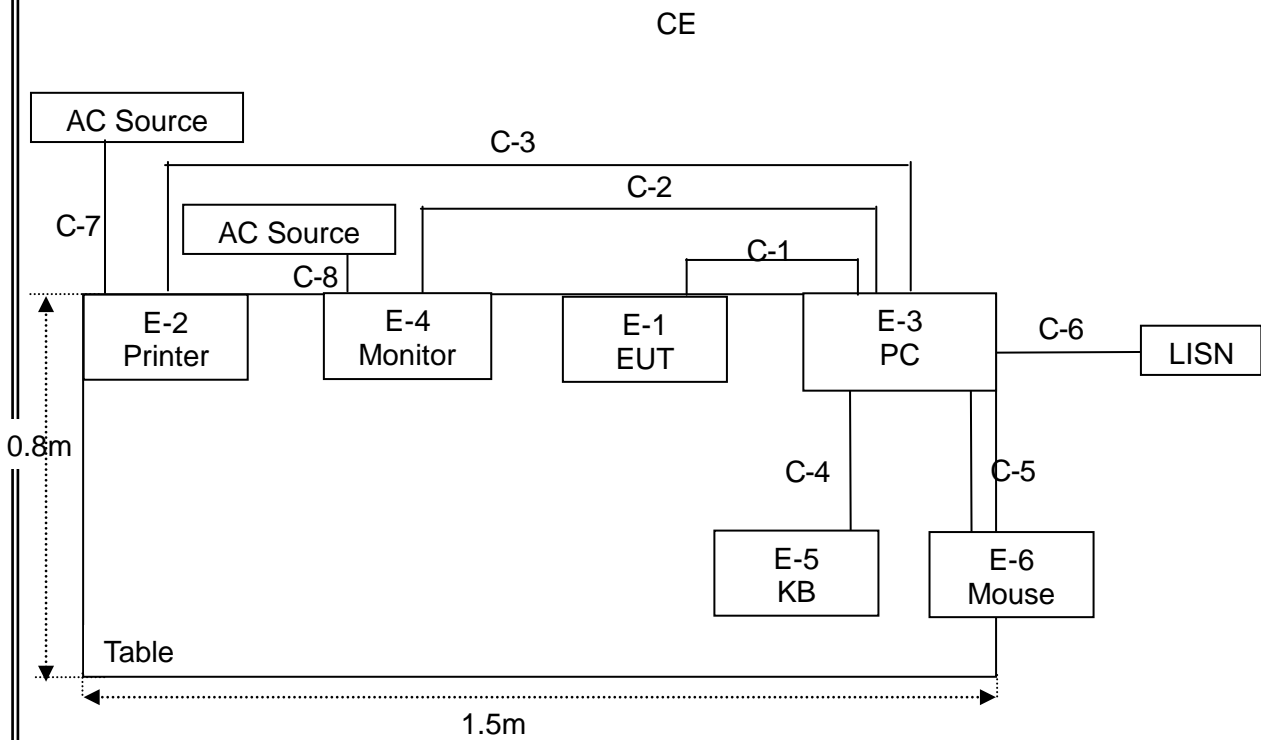
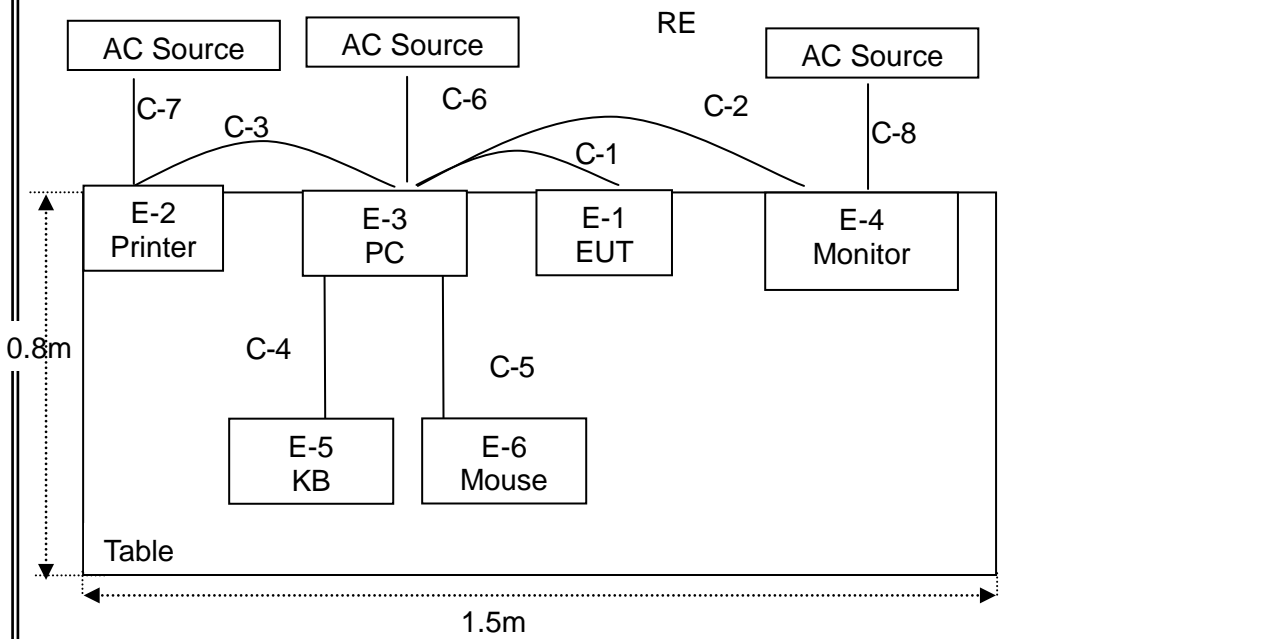

2.3 DESCRIPTION TEST PERIPHERAL AND EUT PERIPHERAL

The EUT has been tested as an independent unit together with other necessary accessories or support units. The following support units or accessories were used to form a representative test configuration during the tests.

Item	Equipment	Brand	Model/Type No.	Series No.	Note
E-1	Bluetooth Speaker		LV580	N/A	EUT
E-2	Printer	Canon	L11121E	LBP2900	
E-3	Personal computer	DELL	FT4Y23X	34413561645	
E-4	Monitor	DELL	IN2020MB	cn-0y6mhx-74261-11f-67es	
E-5	Keyboard	DELL	SK-8185	OY526KUS	
E-6	Mouse	DELL	MS111-P	cn-011d3v-71581-11e-1th7	

Item	Cable Type	Shielded Type	Ferrite Core	Length	Note
C-1	USB Cable	unshielded	NO	1.2m	
C-2	VGA	unshielded	NO	1.0m	
C-3	USB Cable	unshielded	NO	1.2m	
C-4	USB Cable	unshielded	NO	1.0m	
C-5	USB Cable	unshielded	NO	1.0m	
C-6	Power Line	unshielded	NO	1.2m	
C-7	Power Line	unshielded	NO	1.2m	
C-8	Power Line	unshielded	NO	1.2m	

Note:

- (1) The support equipment was authorized by Declaration of Confirmation.
- (2) For detachable type I/O cable should be specified the length in cm in 『Length』 column.
- (3) “YES” means “shielded” “with core”; “NO” means “unshielded” “without core”.

2.4 MEASUREMENT INSTRUMENTS LIST

Radiation Test equipment

Item	Kind of Equipment	Manufacturer	Type No.	Serial No.	Last calibration	Calibrated until	Calibration period
1	Spectrum Analyzer	Agilent	E4407B	MY45108040	2016.07.06	2017.07.05	1 year
2	Test Receiver	R&S	ESPI	101318	2016.06.07	2017.06.06	1 year
3	Bilog Antenna	TESEQ	CBL6111D	31216	2016.07.06	2017.07.05	1 year
4	50Ω Coaxial Switch	Anritsu	MP59B	6200264416	2016.06.07	2017.06.06	1 year
5	Spectrum Analyzer	ADVANTEST	R3132	150900201	2016.06.07	2017.06.06	1 year
6	Horn Antenna	EM	EM-AH-10180	2011071402	2016.07.06	2017.07.05	1 year
7	Horn Ant	Schwarzbeck	BBHA 9170	9170-181	2016.07.06	2017.07.05	1 year
8	Amplifier	EM	EM-30180	060538	2016.07.06	2017.07.05	1 year
9	Loop Antenna	ARA	PLA-1030/B	1029	2016.06.07	2017.06.06	1 year
10	Power Meter	R&S	NRVS	100696	2016.07.06	2017.07.05	1 year
11	Power Sensor	R&S	URV5-Z4	0395.1619.05	2016.07.06	2017.07.05	1 year
12	Test Cable	N/A	R-01	N/A	2016.07.06	2017.07.05	1 year
13	Test Cable	N/A	R-02	N/A	2016.07.06	2017.07.05	1 year

Conduction Test equipment

Item	Kind of Equipment	Manufacturer	Type No.	Serial No.	Last calibration	Calibrated until	Calibration period
1	Test Receiver	R&S	ESCI	101160	2016.06.06	2017.06.05	1 year
2	LISN	R&S	ENV216	101313	2015.08.24	2016.08.23	1 year
3	LISN	EMCO	3816/2	00042990	2015.08.24	2016.08.23	1 year
4	50Ω Coaxial Switch	Anritsu	MP59B	6200264417	2016.06.07	2017.06.06	1 year
5	Passive Voltage Probe	R&S	ESH2-Z3	100196	2016.06.07	2017.06.06	1 year
6	Absorbing clamp	R&S	MOS-21	100423	2016.06.08	2017.06.07	1 year
7	Test Cable	N/A	C01	N/A	2016.06.08	2017.06.07	1 year
8	Test Cable	N/A	C02	N/A	2016.06.08	2017.06.07	1 year
9	Test Cable	N/A	C03	N/A	2016.06.08	2017.06.07	1 year

3. EMC EMISSION TEST

3.1 CONDUCTED EMISSION MEASUREMENT

3.1.1 POWER LINE CONDUCTED EMISSION (Frequency Range 150KHz-30MHz)

FREQUENCY (MHz)	Class A (dBuV)		Class B (dBuV)	
	Quasi-peak	Average	Quasi-peak	Average
0.15 -0.5	79.00	66.00	66 - 56 *	56 - 46 *
0.50 -5.0	73.00	60.00	56.00	46.00
5.0 -30.0	73.00	60.00	60.00	50.00

Note:

- (1) The tighter limit applies at the band edges.
- (2) The limit of " * " marked band means the limitation decreases linearly with the logarithm of the frequency in the range.

The following table is the setting of the receiver

Receiver Parameters	Setting
Attenuation	10 dB
Start Frequency	0.15 MHz
Stop Frequency	30 MHz
IF Bandwidth	9 kHz

3.1.2 TEST PROCEDURE

- a. The EUT was placed 0.8 meters from the horizontal ground plane with EUT being connected to the power mains through a line impedance stabilization network (LISN). All other support equipments powered from additional LISN(s). The LISN provide 50 Ohm/ 50uH of coupling impedance for the measuring instrument.
- b. Interconnecting cables that hang closer than 40 cm to the ground plane shall be folded back and forth in the center forming a bundle 30 to 40 cm long.
- c. I/O cables that are not connected to a peripheral shall be bundled in the center. The end of the cable may be terminated, if required, using the correct terminating impedance. The overall length shall not exceed 1 m.
- d. LISN at least 80 cm from nearest part of EUT chassis.
- e. For the actual test configuration, please refer to the related Item –EUT Test Photos.

3.1.3 TEST SETUP

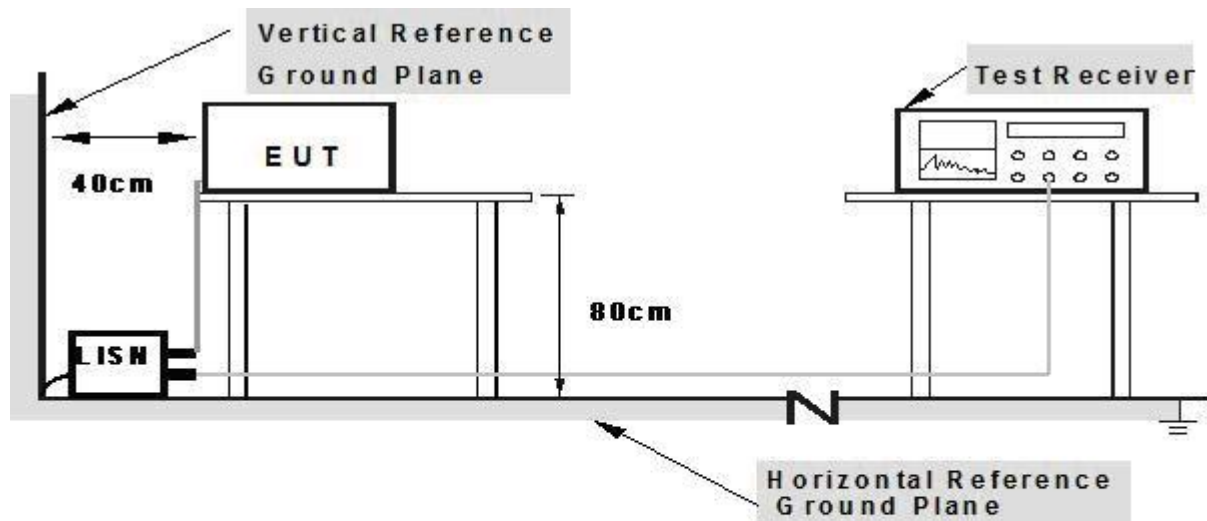

Note: 1. Support units were connected to second LISN.

2. Both of LISNs (AMN) are 80 cm from EUT and at least 80 cm from other units and other metal planes

3.1.4 EUT OPERATING CONDITIONS

The EUT tested system was configured as the statements of 2.3 Unless otherwise a special operating condition is specified in the follows during the testing.

3.1.5 TEST RESULTS

EUT:	Bluetooth Speaker	Model Name. :	LV580
Temperature:	26 °C	Relative Humidity:	54%
Pressure:	1010hPa	Test Date:	2016-7-28
Test Mode:	Mode 1	Phase :	L
Test Voltage:	DC 5V From PC AC 120V/60Hz		

Frequency (MHz)	Reading Level (dBμV)	Correct Factor (dB)	Measure-ment (dBμV)	Limits (dBμV)	Margin (dB)	Remark
0.234	30.13	10.13	40.26	62.3	-22.04	QP
0.234	18.12	10.13	28.25	52.3	-24.05	AVG
0.5655	36.89	9.79	46.68	56	-9.32	QP
0.5655	16.73	9.79	26.52	46	-19.48	AVG
0.7177	37.34	9.78	47.12	56	-8.88	QP
0.7177	19.55	9.78	29.33	46	-16.67	AVG
1.018	38.57	9.85	48.42	56	-7.58	QP
1.018	15.73	9.85	25.58	46	-20.42	AVG
1.9375	36.29	9.74	46.03	56	-9.97	QP
1.9375	20.71	9.74	30.45	46	-15.55	AVG
4.3897	33.88	9.75	43.63	56	-12.37	QP
4.3897	21.27	9.75	31.02	46	-14.98	AVG

Remark:

1. All readings are Quasi-Peak and Average values.
2. Factor = Insertion Loss + Cable Loss.

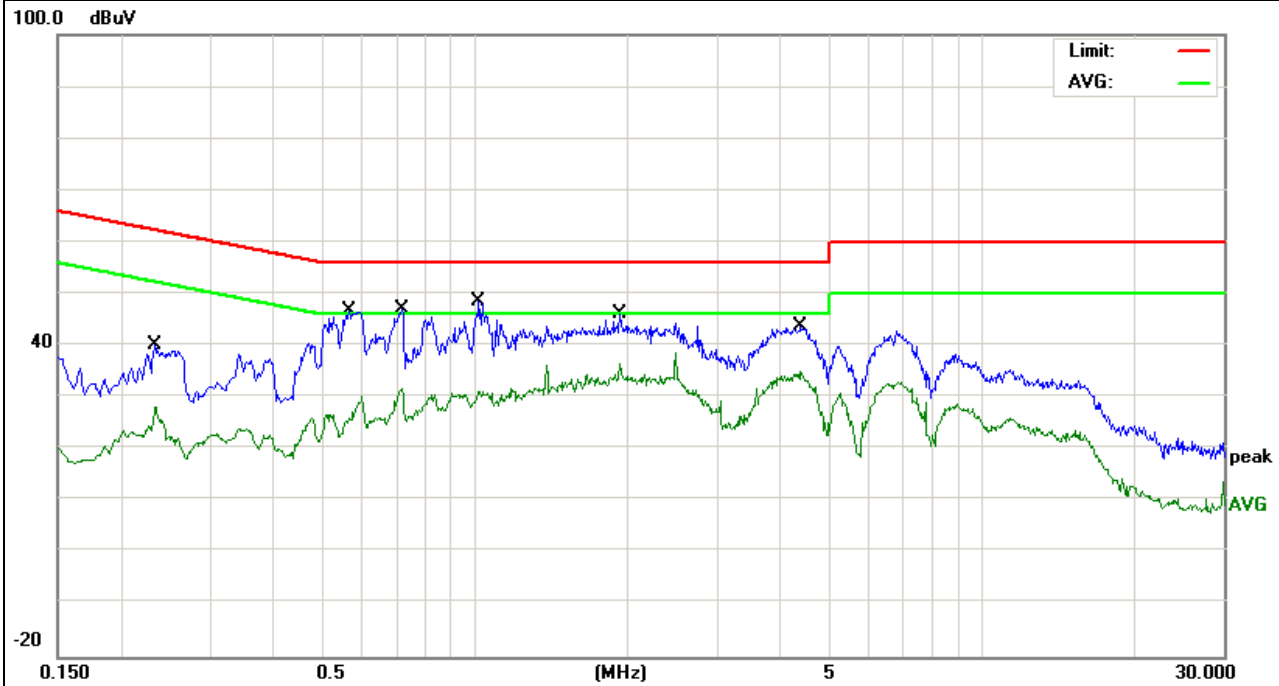

EUT:	Bluetooth Speaker	Model Name. :	LV580
Temperature:	26 °C	Relative Humidity:	54%
Pressure:	1010hPa	Test Date:	2016-7-28
Test Mode:	Mode 1	Phase :	N
Test Voltage:	DC 5V From PC AC 120V/60Hz		

Frequency (MHz)	Reading Level (dBμV)	Correct Factor (dB)	Measure-ment (dBμV)	Limits (dBμV)	Margin (dB)	Remark
0.2379	33.1	10.06	43.16	62.17	-19.01	QP
0.2379	17.38	10.06	27.44	52.17	-24.73	AVG
0.522	40.12	9.82	49.94	56	-6.06	QP
0.522	19.53	9.82	29.35	46	-16.65	AVG
0.5695	39.74	9.82	49.56	56	-6.44	QP
0.5695	16.77	9.82	26.59	46	-19.41	AVG
0.7217	38.95	9.81	48.76	56	-7.24	QP
0.7217	15.77	9.81	25.58	46	-20.42	AVG
1.014	37.42	9.87	47.29	56	-8.71	QP
1.014	15.6	9.87	25.47	46	-20.53	AVG
4.2778	34.7	9.72	44.42	56	-11.58	QP
4.2778	20.75	9.72	30.47	46	-15.53	AVG

Remark:

1. All readings are Quasi-Peak and Average values.
2. Factor = Insertion Loss + Cable Loss.

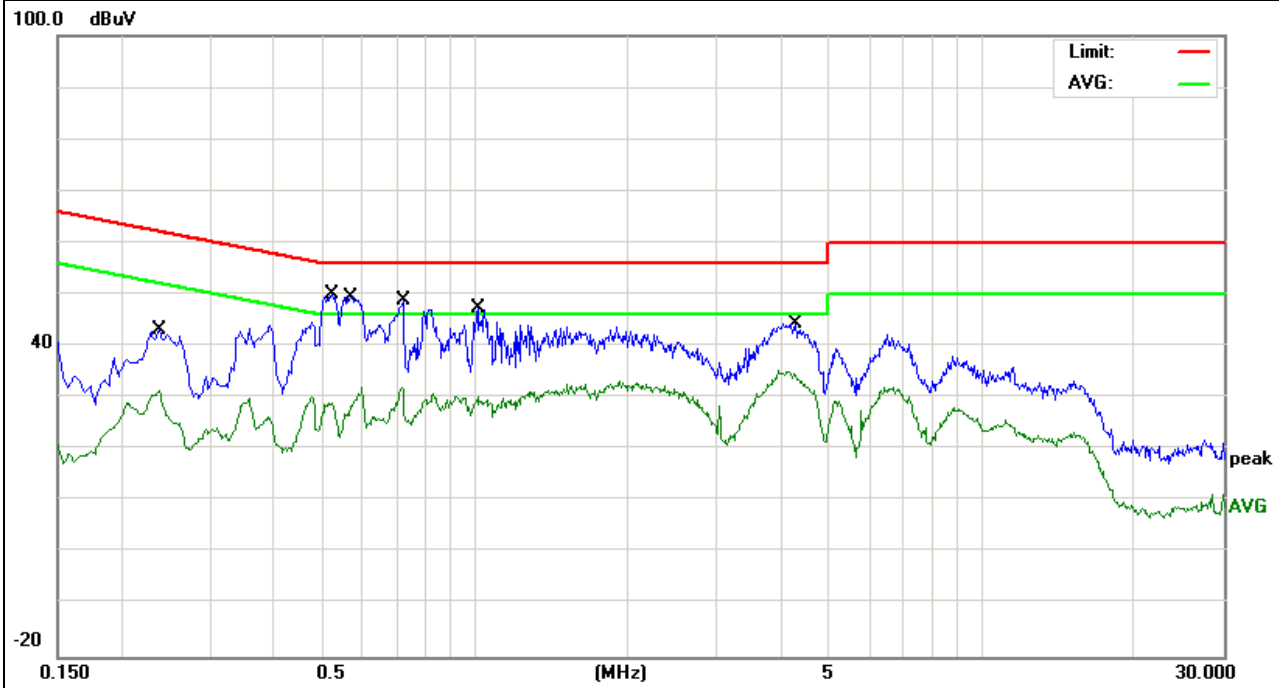

EUT:	Bluetooth Speaker	Model Name. :	LV580
Temperature:	26 °C	Relative Humidity:	54%
Pressure:	1010hPa	Test Date:	2016-7-28
Test Mode:	Mode 1	Phase :	L
Test Voltage:	DC 5V From PC AC 240V/50Hz		

Frequency (MHz)	Reading Level (dBμV)	Correct Factor (dB)	Measure-ment (dBμV)	Limits (dBμV)	Margin (dB)	Remark
0.518	37.11	9.8	46.91	56	-9.09	QP
0.518	17.78	9.8	27.58	46	-18.42	AVG
0.5698	38	9.79	47.79	56	-8.21	QP
0.5698	18.95	9.79	28.74	46	-17.26	AVG
0.7138	37.86	9.78	47.64	56	-8.36	QP
0.7138	17.2	9.78	26.98	46	-19.02	AVG
0.8059	36.95	9.8	46.75	56	-9.25	QP
0.8059	18.64	9.8	28.44	46	-17.56	AVG
1.0339	36.73	9.85	46.58	56	-9.42	QP
1.0339	17.3	9.85	27.15	46	-18.85	AVG
4.03	35.39	9.75	45.14	56	-10.86	QP
4.03	19.27	9.75	29.02	46	-16.98	AVG

Remark:

1. All readings are Quasi-Peak and Average values.
2. Factor = Insertion Loss + Cable Loss.

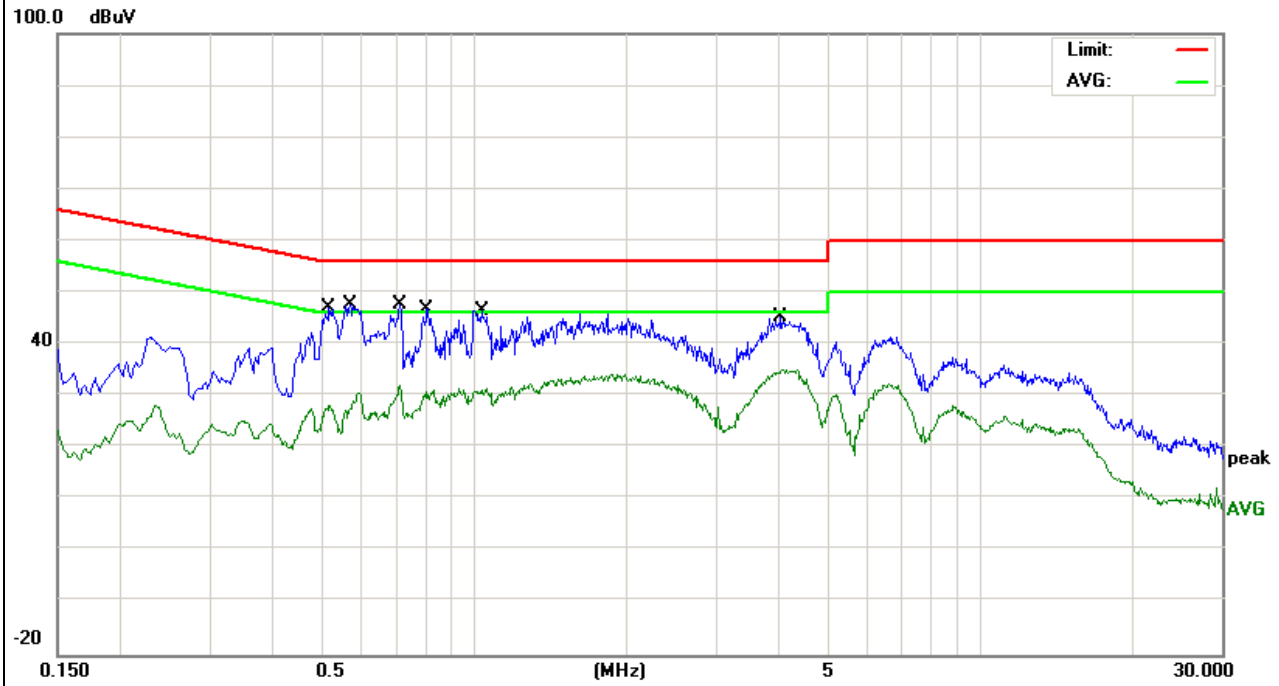

EUT:	Bluetooth Speaker	Model Name. :	LV580
Temperature:	26 °C	Relative Humidity:	54%
Pressure:	1010hPa	Test Date:	2016-7-28
Test Mode:	Mode 1	Phase :	N
Test Voltage:	DC 5V From PC AC 240V/50Hz		

Frequency (MHz)	Reading Level (dBμV)	Correct Factor (dB)	Measure-ment (dBμV)	Limits (dBμV)	Margin (dB)	Remark
0.518	41.69	9.82	51.51	56	-4.49	QP
0.518	18.5	9.82	28.32	46	-17.68	AVG
0.7138	39.76	9.81	49.57	56	-6.43	QP
0.7138	19.21	9.81	29.02	46	-16.98	AVG
0.8138	37.86	9.83	47.69	56	-8.31	QP
0.8138	18.58	9.83	28.41	46	-17.59	AVG
1.038	39.08	9.87	48.95	56	-7.05	QP
1.038	16.71	9.87	26.58	46	-19.42	AVG
1.9458	35.5	9.76	45.26	56	-10.74	QP
1.9458	18.68	9.76	28.44	46	-17.56	AVG
4.3018	35.55	9.72	45.27	56	-10.73	QP
4.3018	17.44	9.72	27.16	46	-18.84	AVG

Remark:

1. All readings are Quasi-Peak and Average values.
2. Factor = Insertion Loss + Cable Loss.

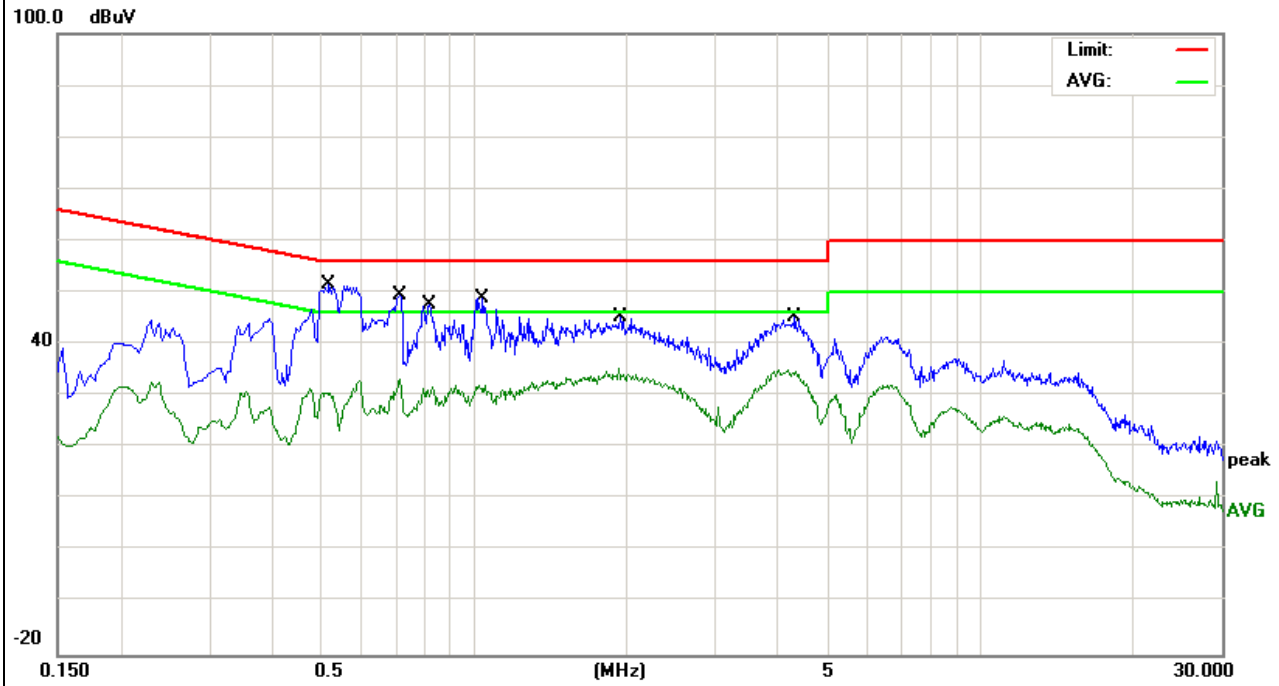

3.2 RADIATED EMISSION MEASUREMENT

3.2.1 LIMITS OF RADIATED EMISSION MEASUREMENT

FREQUENCY (MHz)	Class A (at 10m)	Class B (at 3m)
	dBuV/m	dBuV/m
30 ~ 88	39.0	40.0
88 ~ 216	43.5	43.5
216 ~ 960	46.5	46.0
Above 960	49.5	54.0

Notes:

- (1) The limit for radiated test was performed according to as following:
FCC PART 15B /ICES-003.
- (2) The tighter limit applies at the band edges.
- (3) Emission level (dBuV/m)=20log Emission level (uV/m).

3.2.2 TEST PROCEDURE

Test Arrangement for Radiated Emissions up to 1 GHz

- a. The EUT was placed on the top of a rotating table 0.8 meters above the ground at an accredited test facility. The table was rotated 360 degrees to determine the position of the highest radiation.
- b. The EUT was set 3 meters away from the interference-receiving antenna, which was mounted on the top of a variable-height antenna tower.
- c. The antenna is a broadband antenna, and its height is varied from one meter to four meters above the ground to determine the maximum value of the field strength. Both horizontal and vertical polarizations of the antenna are set to make the measurement.
- d. For each suspected emission, the EUT was arranged to its worst case and then the antenna was tuned to heights from 1 meter to 4 meters and the rotatable table was turned from 0 degrees to 360 degrees to find the maximum reading.

Note: The resolution bandwidth and video bandwidth of test receiver/spectrum analyzer is 120kHz for quasi-peak detection (QP) at frequency below 1GHz.

Test Arrangement for Radiated Emissions above 1 GHz.

- a. The EUT was placed on the top of a rotating table 0.8 meters above the ground at an accredited chamber room. The table was rotated 360 degrees to determine the position of the highest radiation.
- b. The EUT was set 3 meters away from the interference-receiving antenna, which was mounted on the top of a variable-height antenna tower.
- c. The height of antenna can be varied from one meter to four meters, the height of adjustment depends on the EUT height and the antenna 3dB beamwidth both, to detect the maximum value of the field strength.Both horizontal and vertical polarizations of the antenna are set to make the measurement.
- d. For each suspected emission, the EUT was arranged to its worst case and then the antenna was tuned to heights and the rotatable table was turned from 0 degrees to 360 degrees to find the maximum reading.

Note: For the hand-held device, the EUT should be measured for all 3 axes and only the worst case is recorded in the report
 During the radiated emission test, the Spectrum Analyzer was set with the following configurations:

Frequency Band (MHz)	Function	Resolution bandwidth	Video Bandwidth
30 to 1000	QP	120 kHz	300 kHz
Above 1000	Peak	1 MHz	1 MHz
	Avg	1 MHz	10 Hz

3.2.3 TEST SETUP

For Radiated Emission 30~1000MHz

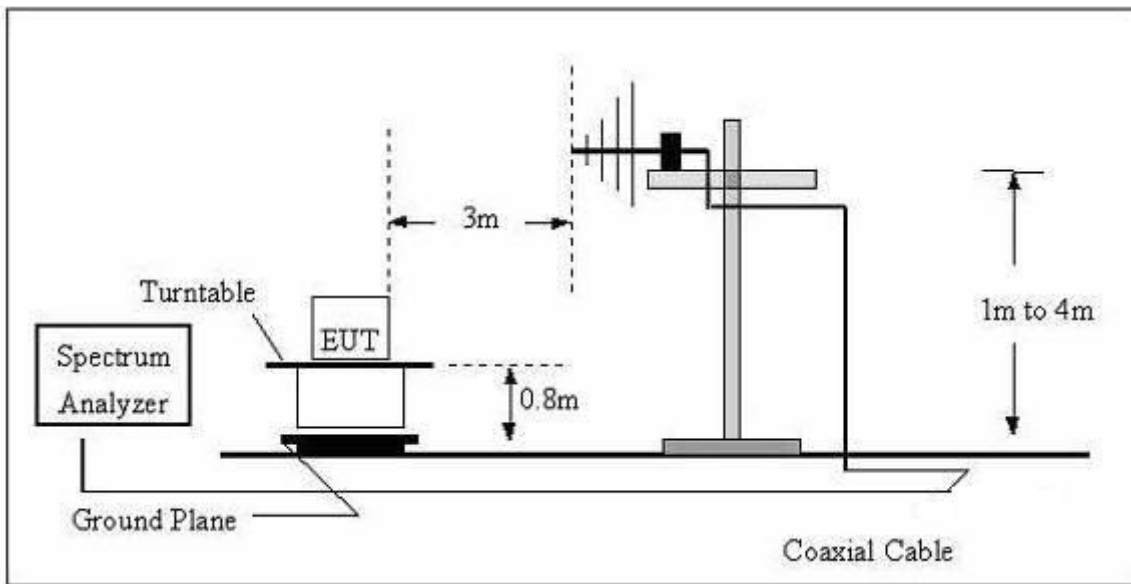

(B) Radiated Emission Test Set-Up Frequency Above 1GHz

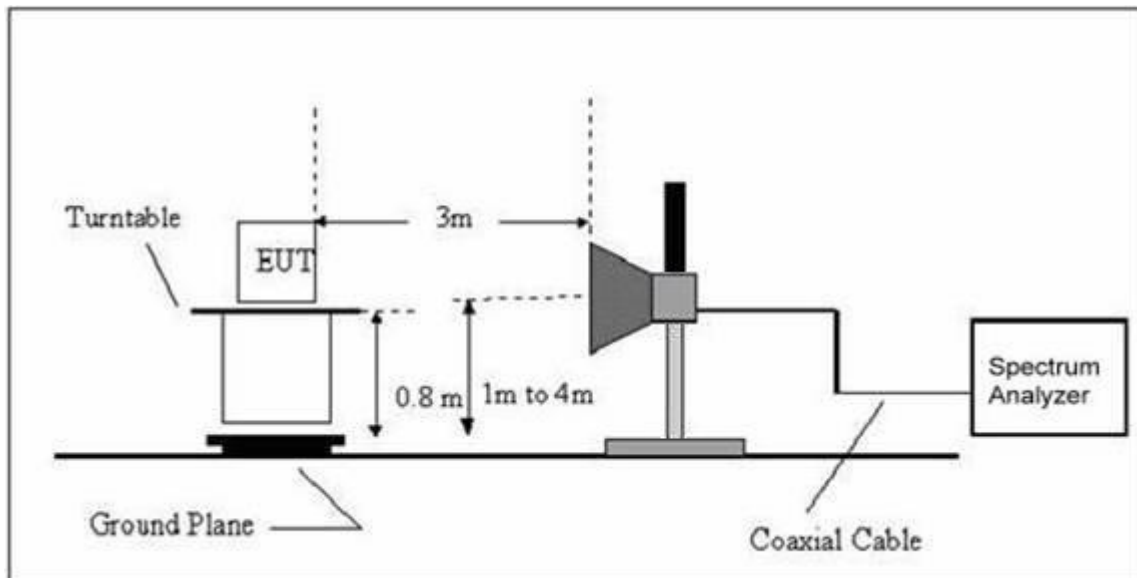

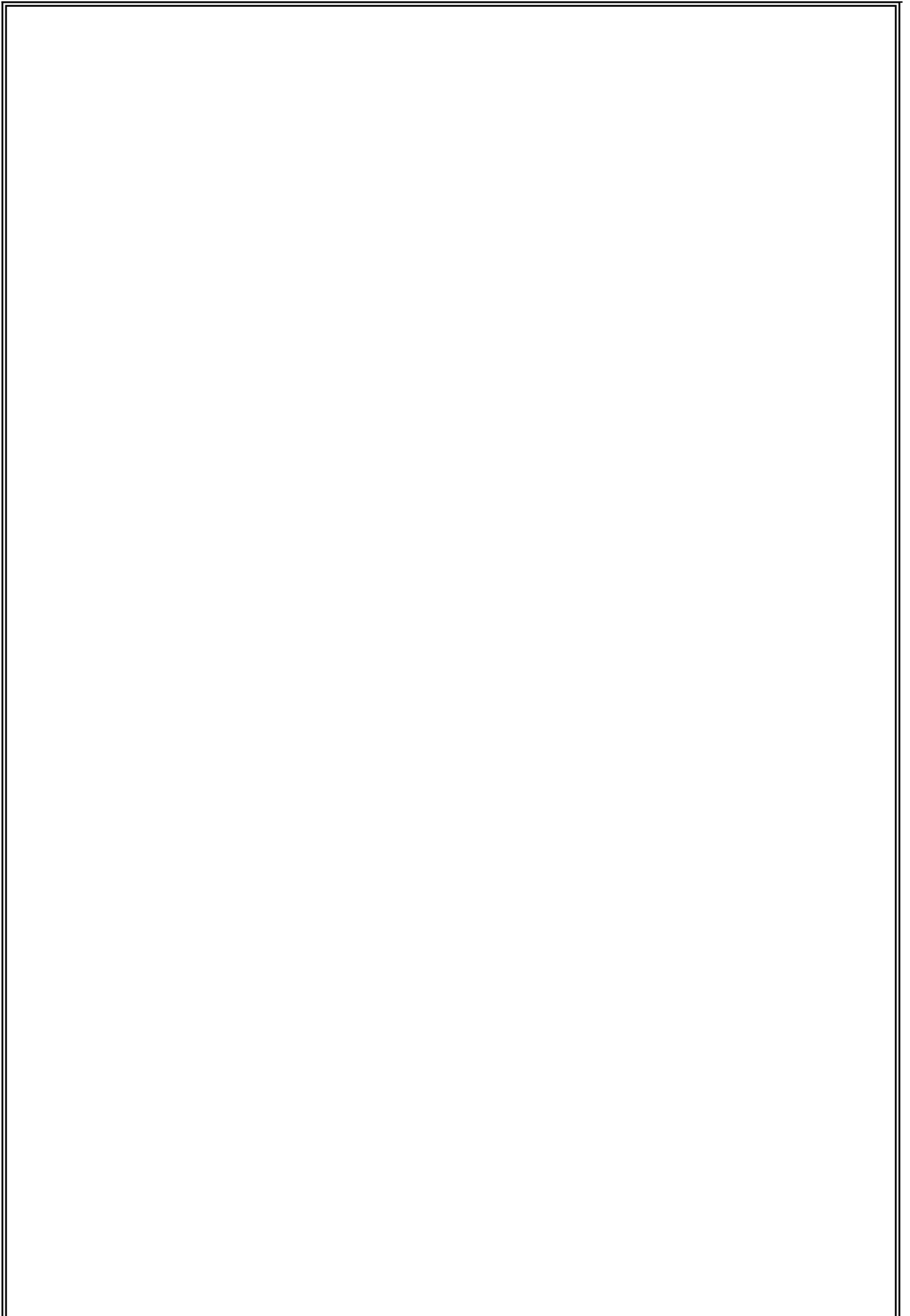

3.2.4 TEST RESULTS

TEST RESULTS (30~1000 MHz)

EUT:	Bluetooth Speaker	Model Name:	LV580
Temperature:	24 °C	Relative Humidity:	54%
Pressure:	1010 hPa	Test Date :	2016-7-28
Test Mode :	Mode 1	Polarization :	Horizontal
Test Power :	DC 5V From PC AC 120V/60Hz		

Polar (H/V)	Frequency	Meter Reading	Factor	Emission Level	Limits	Margin	Remark
	(MHz)	(dBuV)	(dB)	(dBuV/m)	(dBuV/m)	(dB)	
H	47.9938	25.22	10.57	35.79	40	-4.21	QP
H	50.7637	26.41	9.99	36.4	40	-3.6	QP
H	128.5629	24.98	11.93	36.91	43.5	-6.59	QP
H	344.3854	25.63	15.3	40.93	46	-5.07	QP
H	404.6664	26.3	16.06	42.36	46	-3.64	QP
H	810.2653	17.81	24.15	41.96	46	-4.04	QP

Remark:
Factor = Antenna Factor + Cable Loss - Amplifier.

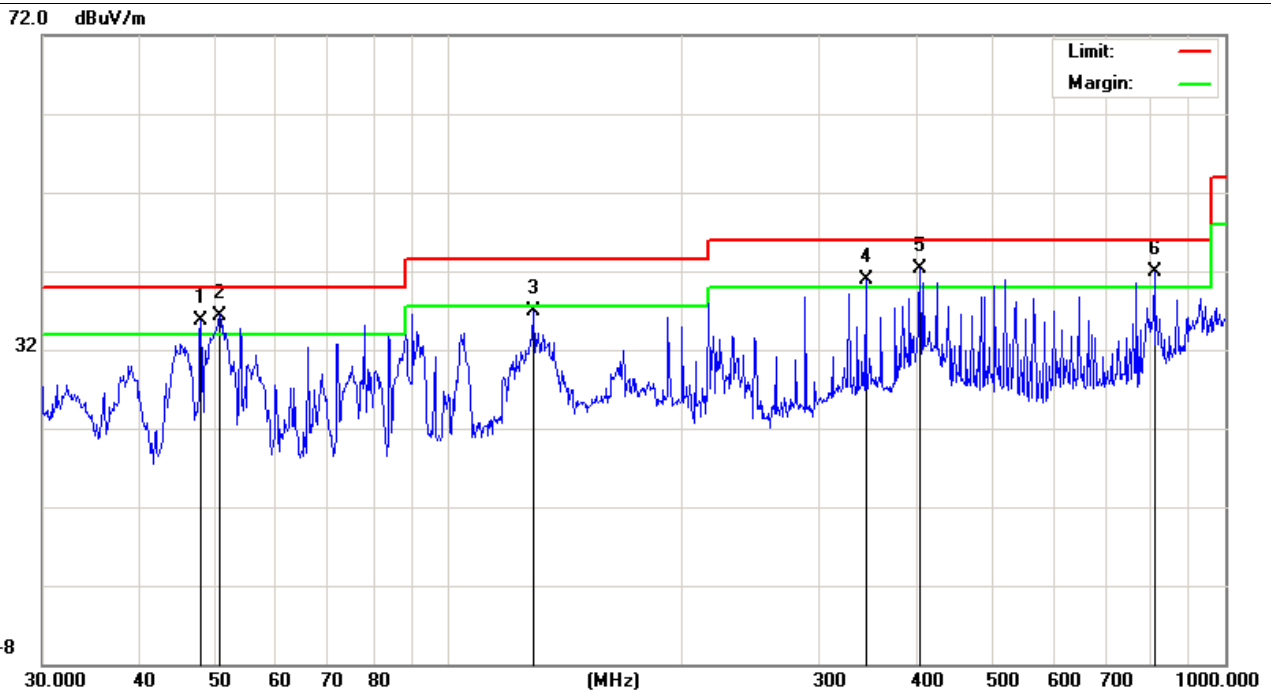

EUT:	Bluetooth Speaker	Model Name :	LV580
Temperature:	24 °C	Relative Humidity:	54%
Pressure:	1010 hPa	Test Date :	2016-7-28
Test Mode :	Mode 1	Polarization :	Vertical
Test Power :	DC 5V From PC AC 120V/60Hz		

Polar (H/V)	Frequency	Meter Reading	Factor	Emission Level	Limits	Margin	Remark
	(MHz)	(dBuV)	(dB)	(dBuV/m)	(dBuV/m)	(dB)	
V	38.7518	19.61	15.93	35.54	40	-4.46	QP
V	47.9938	24.97	10.57	35.54	40	-4.46	QP
V	129.9225	27.56	11.99	39.55	43.5	-3.95	QP
V	199.9856	25.65	12.75	38.4	43.5	-5.1	QP
V	327.8872	26.87	14.83	41.7	46	-4.3	QP
V	344.3854	26.58	15.3	41.88	46	-4.12	QP

Remark:

Factor = Antenna Factor + Cable Loss - Amplifier.

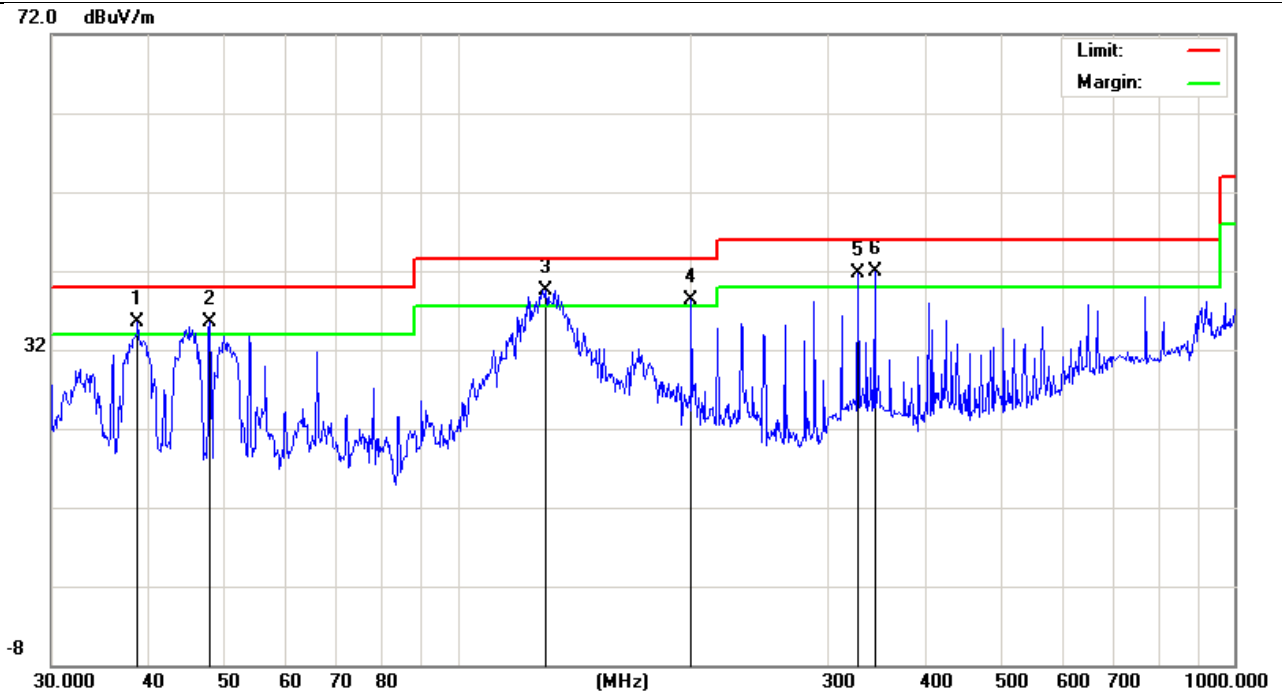

3.2.5 TEST RESULTS(1000~25000MHz)

The Testing have been conformed to $10 \times 2462\text{MHz} = 24620\text{MHz}$, and the worst result was report as below:

Polar (H/V)	Frequency	Meter Reading	Factor	Emission Level	Limits	Margin	Remark
	(MHz)	(dBuV)	(dB)	(dBuV/m)	(dBuV/m)	(dB)	
V	1566.021	59.33	-9.27	50.06	74	-23.94	peak
V	1566.021	48.25	-9.27	38.98	54	-15.02	AVG
V	2251.334	56.59	-6.98	49.61	74	-24.39	peak
V	2251.334	45.32	-6.98	38.34	54	-15.66	AVG
V	2911.056	60.15	-7.54	52.61	74	-21.39	peak
V	2911.056	43.26	-7.54	35.72	54	-18.28	AVG
H	1277.141	58.15	-10.75	47.4	74	-26.6	peak
H	1277.141	43.25	-10.75	32.5	54	-21.5	AVG
H	1933.032	66.02	-9.63	56.39	74	-17.61	peak
H	1933.032	52.54	-9.63	42.91	54	-11.09	AVG
H	3156.114	57.47	-6.24	51.23	74	-22.77	peak
H	3156.114	42.15	-6.24	35.91	54	-18.09	AVG

Remark:

Absolute Level= ReadingLevel+ Factor, Margin= Absolute Level - Limit

4. EUT TEST PHOTO

Radiated Measurement Photos

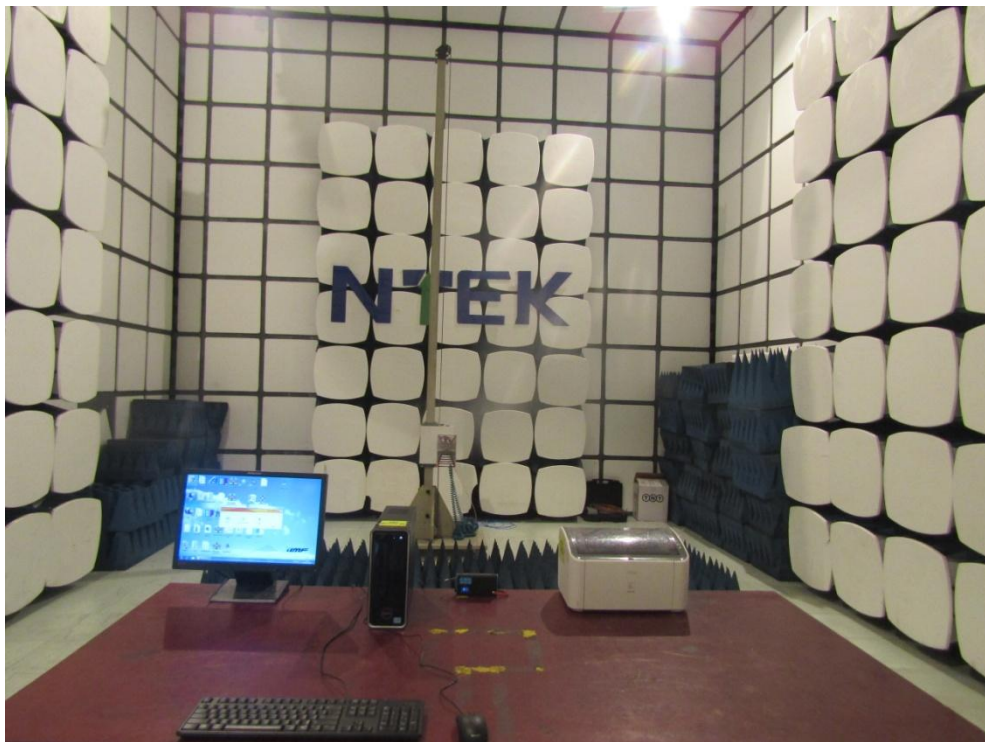
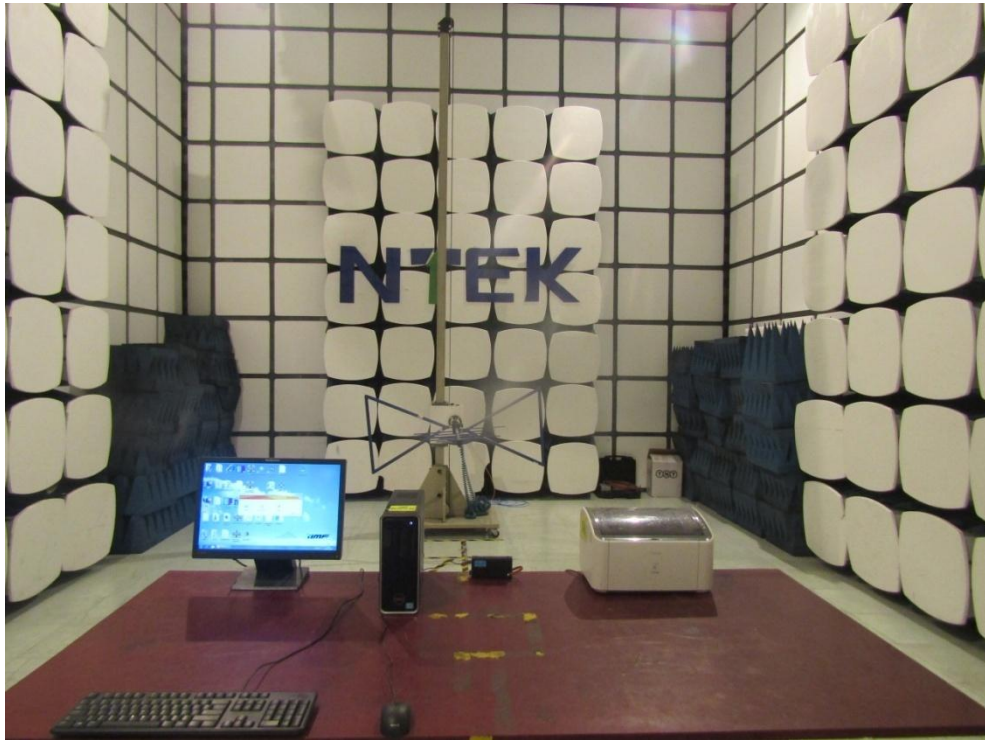

Conducted Measurement Photos

