



TEST REPORT

FCC ID: 2ABNA-TRM101

Applicant : Guangzhou Geoelectron Science & Technology Company Limited
Address : No.704, 7/F, Building C, No.7, Cai Pin Road, Science City, Luogang
District, Guangzhou, China

Equipment under Test (EUT):

Name	:	Wireless Data Transceiver Module
Model	:	TRM101
Trademark	:	Geoelectron

Standards: FCC PART 90: 2015, TIA/EIA-603-D: 2010

Report No : T1861045 06
Date of Test : June 12, 2016- June 24, 2016
Date of Issue : June 28, 2016

Test Result : PASS

In the configuration tested, the EUT complied with the standards specified above
Authorized Signature

(Mark Zhu)
Manager

The manufacture should ensure that all the products in series production are in conformity with the product sample detailed in this report. If the product in this report is used in any configuration other than that detailed in the report, the manufacturer must ensure the new system complies with all relevant standards. Any mention of Shenzhen Alpha Product Testing Co., Ltd. Or test done by Shenzhen Alpha Product Testing Co., Ltd. Approvals in connection with, distribution or use of the product described in this report must be approved by Shenzhen Alpha Product Testing Co., Ltd. Approvals in writing.

TABLE OF CONTENT

1 General Information	4
1.1 Description of Device (EUT)	4
1.2 Description of Test Facility	5
2 EMC Equipment List	5
3 Test Procedure	7
4 Summary of Measurement	8
4.1 Summary of test result	8
4.2 Test connection	8
4.3 Assistant equipment used for test	9
4.4 Test mode	9
4.5 Test Conditions	10
4.6 Measurement Uncertainty (95% confidence levels, k=2)	10
5 Transmitter Power(Conducted)	11
5.1 Test limit	11
5.2 Test Setup	11
5.3 Test Results	11
6 99% Occupied Bandwidth	13
6.1 Test limit	13
6.2 Test Setup	13
6.3 Test Results	13
7 Spectrum Emission Mask	17
7.1 Test limit	17
7.2 Test Setup	17
7.3 Test Results	17
8 Spurious Emissions(conducted)	21
8.1 Test limit	21
8.2 Test Setup	21
8.3 Test Result	21
9 Radiation Emission Spurious Emissions(Radiated)	28
9.1 Radiation Emission Limits(90.210)	28
9.1.1 Test Setup	28
9.1.2 Test Procedure	29
9.1.3 Test Equipment Setting For emission test Result	30
9.1.4 Test Condition	30
9.1.5 Test Result	30
10 Transient Frequency Behavior	33
10.1 Test limit	33
10.2 Test Setup	33
10.3 Test Procedure	33
10.4 Test Result	33
11 Behavior Frequency Stability	36
11.1 Standard Requirement	36
11.2 Test Setup	36
11.3 Test Result	36
12 Test setup photo	38
13 Photos of EUT	39

TEST REPORT VERIFICATION

Applicant : Guangzhou Geoelectron Science & Technology Company Limited
 Manufacturer : Guangzhou Geoelectron Science & Technology Company Limited EUT
 Description : Wireless Data Transceiver Module

(A) Model No. : TRM101
 (B) Trademark : **Geoelectron**
 (C) Ratings Supply : DC 3.3V from Power Source
 (D) Test Voltage : DC 3.3V from Power Source

Measurement Standard Used:

FCC Rules and Regulations Part 90 15, RSS-119 TIA-603-D:2010

The device described above is tested by Shenzhen Alpha Product Testing Co., Ltd. to determine the maximum emission levels emanating from the device. The maximum emission levels are compared to the FCC Part 15 Subpart C limits both conducted and radiated emissions. The test results are contained in this test report and Shenzhen Alpha Product Testing Co., Ltd. is assumed of full responsibility for the accuracy and completeness of these tests.

After the test, our opinion is that EUT compliance with the requirement of the above standards.

This report applies to above tested sample only. This report shall not be reproduced in parts without written approval of Shenzhen Alpha Product Testing Co., Ltd.

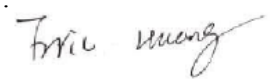
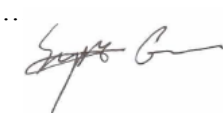
Tested by (name + signature).....:	Eric Huang Test Engineer 
Approved by (name + signature).....:	Simple Guan Project Manager 
Date of issue.....:	June 28, 2016	

1 General Information

1.1 Description of Device (EUT)

Trade Name	:	Geoelectron
EUT	:	Wireless Data Transceiver Module
Model No.	:	TRM101
DIFF	:	N/A
Radio Technology	:	UHF
Antenna Type	:	Integrated Antenna, Gain is 4dBi.
Operation frequency	:	410-470MHz
Modulation	:	GMSK
Channel Spacing	:	12.5KHz, 25KHz
Power Supply	:	DC 3.3V from Power Source
Applicant	:	Guangzhou Geoelectron Science & Technology Company Limited
Address	:	No.704, 7/F, Building C, No.7, Cai Pin Road, Science City, Luogang District, Guangzhou, China
Manufacture	:	Guangzhou Geoelectron Science & Technology Company Limited
Address	:	No.704, 7/F, Building C, No.7, Cai Pin Road, Science City, Luogang District, Guangzhou, China

1.2 Description of Test Facility

Shenzhen Alpha Product Testing Co., Ltd.
Building B, East Area of Nanchang Second, Industrial Zone, Gushu 2nd Road,
Bao'an, Shenzhen, China

March 25, 2015 File on Federal Communication Commission
Registration Number: 203110

July 18, 2014 Certificated by IC
Registration Number: 12135A

2 EMC Equipment List

Equipment	Manufacture	Model No.	Serial No.	Cal. Due day	Cal Interval
3m Semi-Anechoic	ETS-LINDGREN	N/A	SEL0017	2018.01.18	2Year
Spectrum analyzer	Agilent	E4407B	MY46185649	2017.01.16	1Year
Receiver	R&S	ESCI	1166.5950K03-1011	2017.01.16	1Year
Receiver	R&S	ESCI	101202	2017.01.16	1Year
Bilog Antenna	Schwarzbeck	VULB 9168	VULB9168-438	2017.01.21	2Year
Bilog Antenna	Schwarzbeck	VULB 9168	VULB9168-439	2017.01.21	2Year
Horn Antenna	EMCO	3115	640201028-06	2017.01.21	2Year
Horn Antenna	SCHWARZBECK	D:266	BBHA9120D	2017.01.21	2Year
Active Loop Antenna	Beijing Daze	ZN30900A	SEL0097	2017.01.21	2Year
Cable	Resenberger	N/A	No.1	2017.01.16	1Year
Cable	SCHWARZBECK	N/A	No.2	2017.01.16	1Year
Cable	SCHWARZBECK	N/A	No.3	2017.01.16	1Year
Pre-amplifier	Schwarzbeck	BBV9743	9743-019	2017.01.18	1Year

Pre-amplifier	R&S	AFS33-18002650 -30-8P-44	SEL0080	2017.01.18	1Year
Base station	Agilent	E5515C	GB44300243	2017.01.18	1 Year
Temperature controller	Terchy	MHQ	120	2017.01.18	1Year
Power divider	Anritsu	K240C	020346	2017.01.18	1 Year
Signal Generator	HP	83732B	VS3449051	2017.01.18	1 Year
Power Meter	Anritsu	ML2487A	6K00001491	2017.01.18	1Year
Power sensor	Anritsu	ML2491A	32516	2017.01.18	1Year
L.I.S.N.#1	Schwarzbeck	NSLK8126	8126466	2017.01.18	1Year
L.I.S.N.#2	ROHDE&SCHWARZ	ENV216	101043	2017.01.18	1 Year
Digital phosphor Oscilloscope	Tecktronix Inc	DPO4054	C012267	2017.01.18	1 Year
Signal Generator	HP	E4438C	MY45031273	2017.01.18	1 Year
Analyzer, RF Communication Test set	HP	8920A	3438A05227	2017.01.18	1 Year
Attenuator	Bird Electronic Corp.	50-AFFB-30	120540086	2017.01.18	1 Year

3 Test Procedure

RADIATION INTERFERENCE: The test procedure used was TIA-603-D:2010 using a ANRITSU spectrum analyzer with a pre-selector. The analyzer was calibrated in dB above a micro volt at the output of the antenna. The resolution bandwidth was 100kHz and the video bandwidth was 300 kHz up to 1 GHz and 1 MHz with a video BW of 3MHz above 1 GHz. The ambient temperature of the EUT was 25°C with a humidity of 58%.

FORMULA OF CONVERSION FACTORS: The Field Strength at 3m was established by adding the meter reading of the spectrum analyzer (which is set to read in units of dBuV) to the antenna correction factor supplied by the antenna manufacturer and cable loss. The antenna correction factors and cable loss are stated in terms of dB. The gain of the Pre-selector was accounted for in the Spectrum Analyzer Meter Reading.

Example:

Freq (MHz) METER READING + ACF + CABLE = FS

33.20 dBuV + 10.36 dB + 0.9 dB = 44.46 dBuV/m @ 3m

TIA-603-D:2010 MEASUREMENT PROCEDURES: The EUT was placed on a table 80 cm high and with dimensions of 1m by 1.5m. The EUT was placed in the center of the table (1.5m side). The table used for radiated measurements is capable of continuous rotation. When an emission was found, the table was rotated to produce the maximum signal strength. At this point, the antenna was raised and lowered from 1m to 4m. The antenna was placed in both the horizontal and vertical planes. The situation was similar for the conducted measurement except that the table did not rotate. The EUT was setup as described in TIA-603-D:2010 with the EUT 40 cm from the vertical ground wall.

4 Summary of Measurement

4.1 Summary of test result

Test Item	Standards Paragraph	Result
Transmitter Power(Conducted)	FCC Part90.205	Compliance
99% Occupied Bandwidth	FCC Part90.210	Compliance
Spectrum Emission Mask	FCC Part90.210	Compliance
Spurious Emissions(conducted)	FCC Part90.210	Compliance
Spurious Emissions(Radiated)	FCC Part90.210	Compliance
Transient Frequency Behavior	FCC Part90.214	Compliance
Frequency Stability	FCC Part90.213	Compliance

Note: The EUT has been tested as an independent unit. And Continual Transmitting in maximum power.

4.2 Test connection

EUT

4.3 Assistant equipment used for test

Description	:	Notebook
Manufacturer	:	ACER
Model No.	:	ZQT
Remark: FCC DOC approved		

4.4 Test mode

Dutycycle :100%		
Keeping TX		
Mode	Channel	Frequency (MHz)
UHF	Low	410
	Middle	440
	High	470
<p>Note: According exploratory test, EUT will have maximum output power in those data rate. so those data rate were used for all test.</p> <p>Note2: The UHF is designed to be capable of transmit voice on public safety frequency in the 450-570MHz band on nationwide public safety, also can transmit data with a power of 1W, with data rate of 4800bits per second per 6.25KHz of channel bandwidth.</p>		

4.5 Test Conditions

Temperature range	21-25°C
Humidity range	40-75%
Pressure range	86-106kPa

4.6 Measurement Uncertainty (95% confidence levels, k=2)

Item	MU	Remark
Uncertainty for Power point Conducted Emissions Test	2.42dB	
Uncertainty for Radiation Emission test in 3m chamber (below 30MHz)	2.13 dB	Polarize: V
	2.57dB	Polarize: H
Uncertainty for Radiation Emission test in 3m chamber (30MHz to 1GHz)	3.54dB	Polarize: V
	4.1dB	Polarize: H
Uncertainty for Radiation Emission test in 3m chamber (1GHz to 25GHz)	2.08dB	Polarize: H
	2.56dB	Polarize: V
Uncertainty for radio frequency	1×10^{-9}	
Uncertainty for conducted RF Power	0.65dB	
Uncertainty for temperature	0.2°C	
Uncertainty for humidity	1%	
Uncertainty for DC and low frequency voltages	0.06%	

5 Transmitter Power(Conducted)

5.1 Test limit

Please refer section FCC Part 90.205&RSS-119 5.4.

5.2 Test Setup

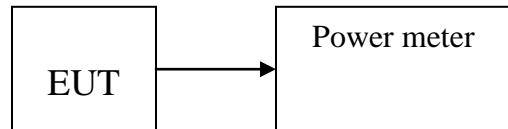

5.3 Test Results

PASS

Detailed information please see the following page.

EUT: Wireless Data Transceiver Module		M/N: TRM101		
Test date: 2016-06-21		Test site: RF site		Tested by: Eric Huang
Mode	Frequency (MHz)	PK Output power(dBm)	Limit (dBm)	Judgment
GMSK 12.5KHz channel spacing	410	30.35	33	Pass
	440	30.17	33	Pass
	470	30.25	33	Pass
Conclusion: PASS				

EUT: Wireless Data Transceiver Module		M/N: TRM101		
Test date: 2016-06-21		Test site: RF site		Tested by: Eric Huang
Mode	Frequency (MHz)	PK Output power(dBm)	Limit (dBm)	Judgment
GMSK 25.0KHz channel spacing	410	30.19	33	Pass
	440	30.26	33	Pass
	470	30.31	33	Pass
Conclusion: PASS				

6 99% Occupied Bandwidth

6.1 Test limit

Please refer section FCC Part 90.210 & RS-119 5.5.

6.2 Test Setup

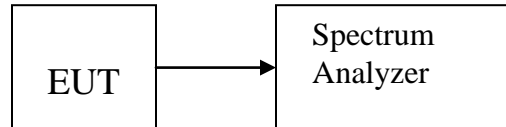

6.3 Test Results

PASS.

Detailed information please see the following page.

Channel	Frequency (MHz)	26dB Bandwidth (KHz)	99% Occupied Bandwidth (KHz)	Result
GMSK 12.5KHz Channel Spacing:				
Low	410	/	9.863	PASS
Mid	440	/	9.970	PASS
High	470	/	9.890	PASS

Channel	Frequency (MHz)	26dB Bandwidth (KHz)	99% Occupied Bandwidth (KHz)	Result
GMSK 25KHz Channel Spacing:				
Low	410	/	19.728	PASS
Mid	440	/	20.019	PASS
High	470	/	19.671	PASS

12.5KHz channel Spacing

GMSK :

CH Low :

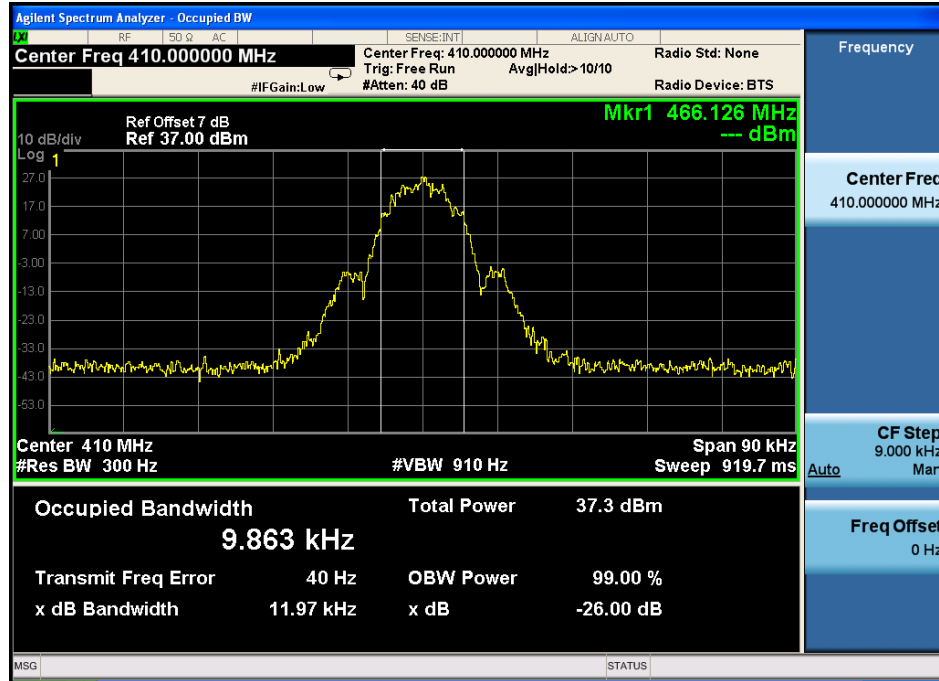

CH Mid:

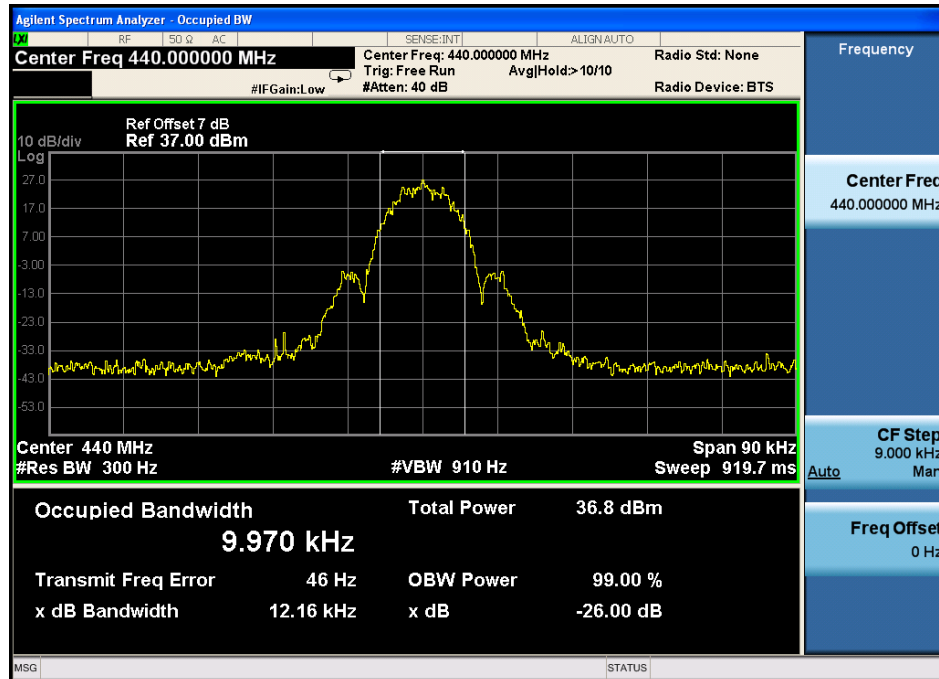

CH Hig:

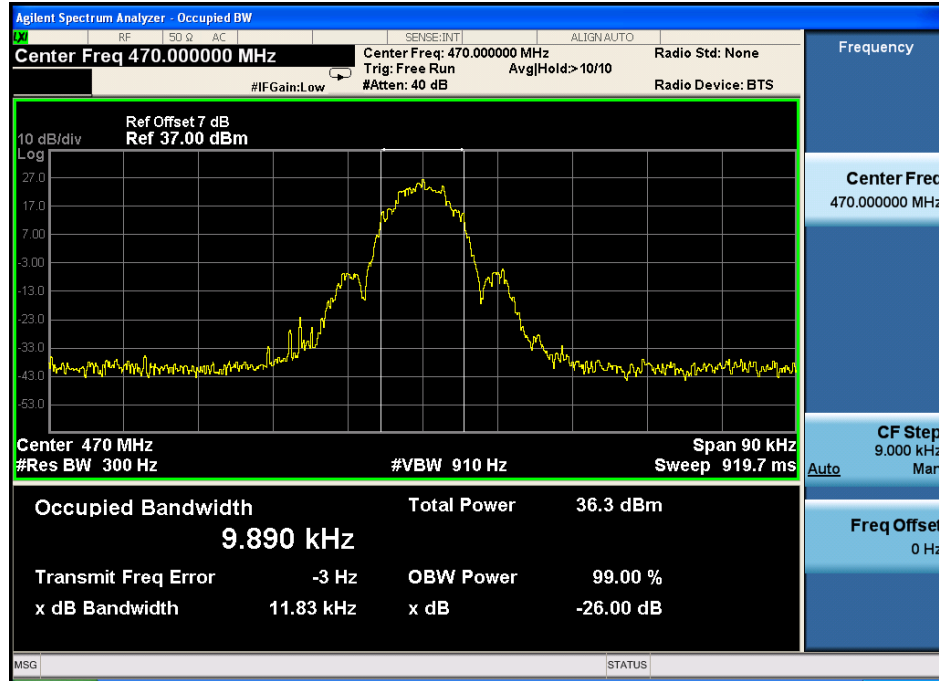

25KHz channel Spacing

GMSK :

CH Low :

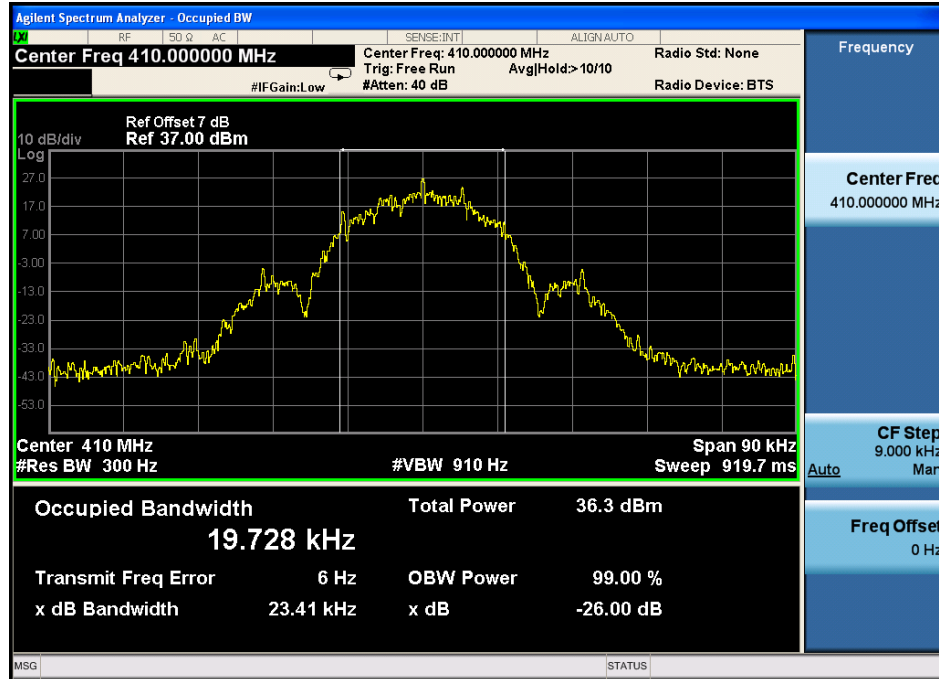

CH Mid:

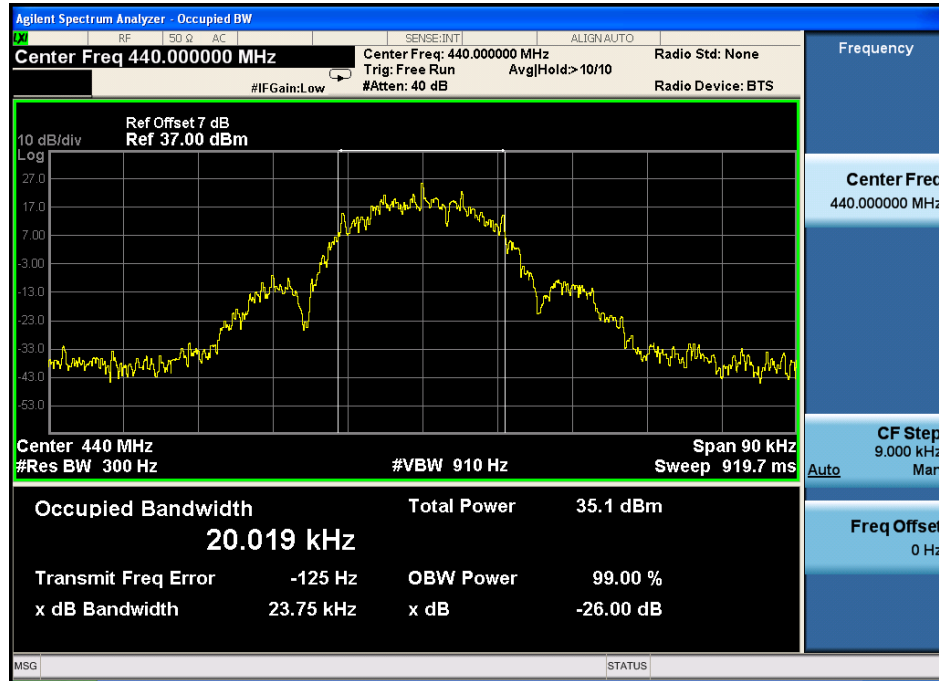

CH Hig:

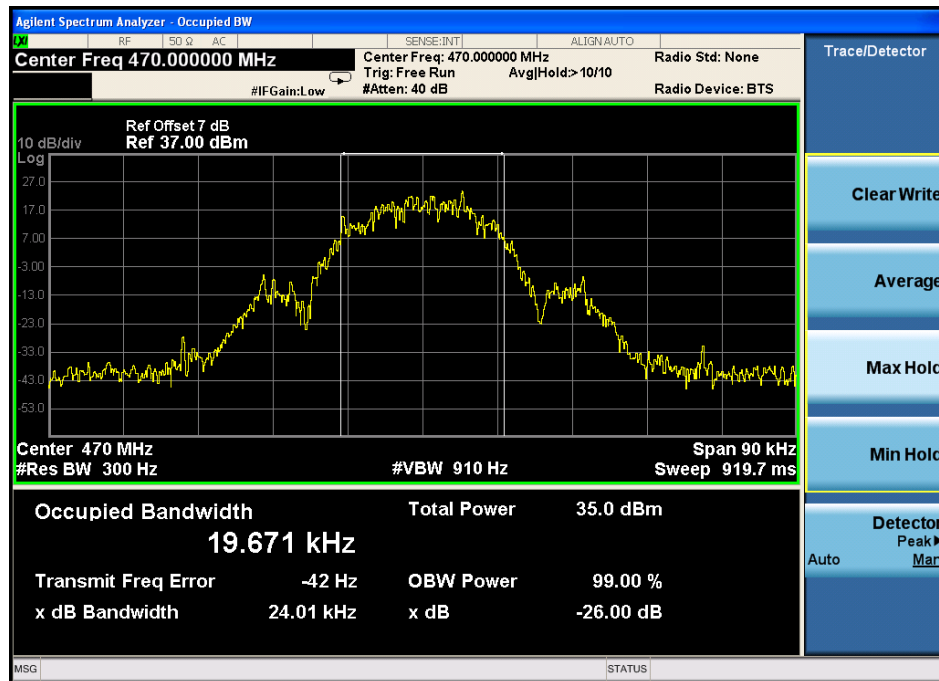

7 Spectrum Emission Mask

7.1 Test limit

FCC Part90.210& RSS-119 5.5

7.2 Test Setup

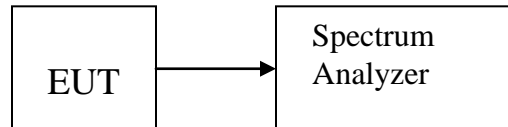

7.3 Test Results

PASS.

Detailed information please see the following page.

12.5KHz Channel Spacing
GMSK:
Ch Low

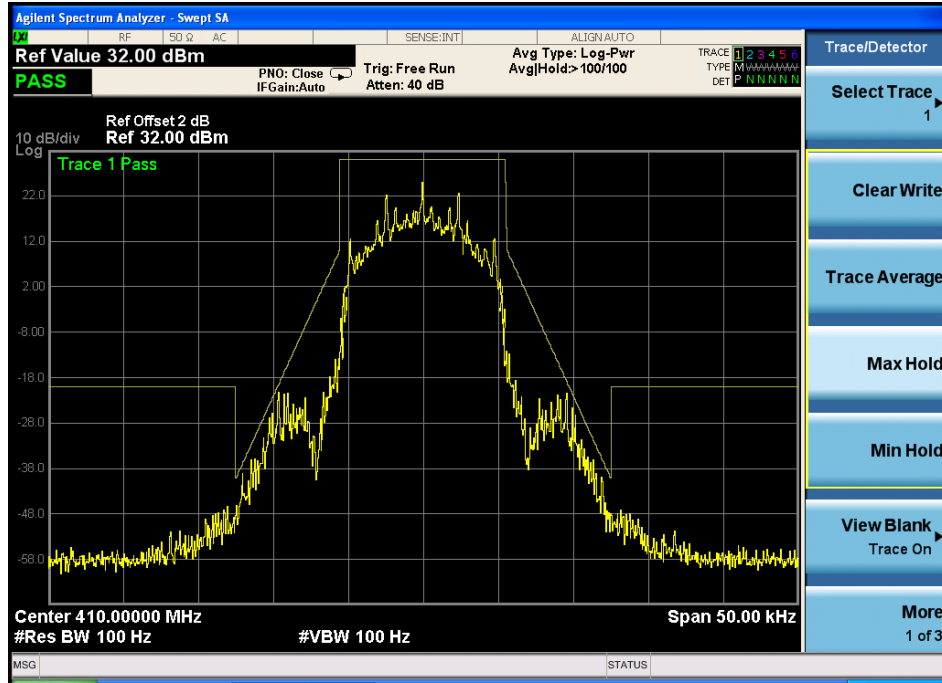

Ch Mid:

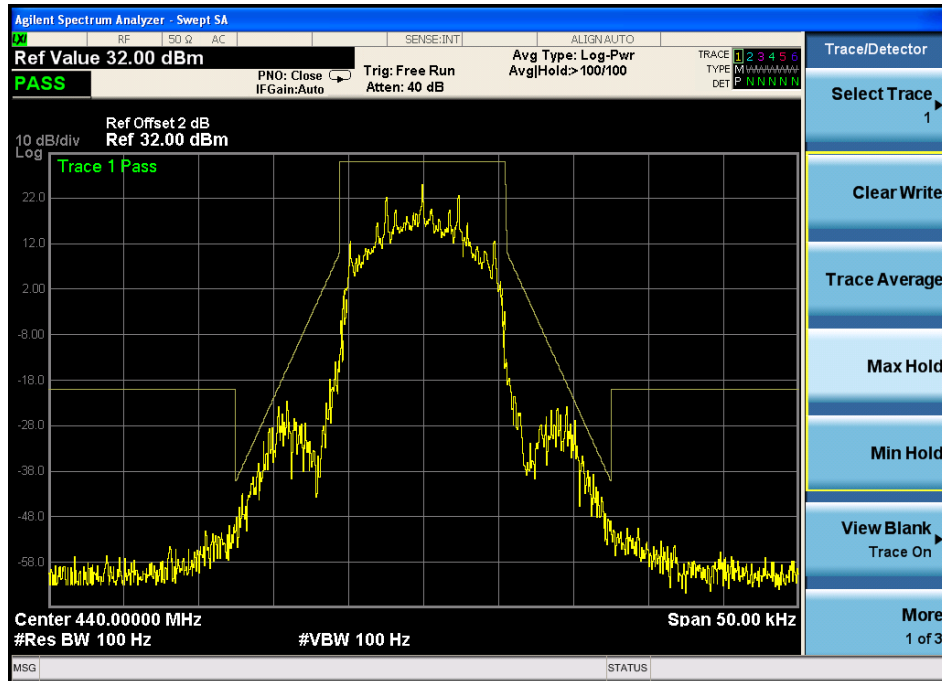

CH Hig:

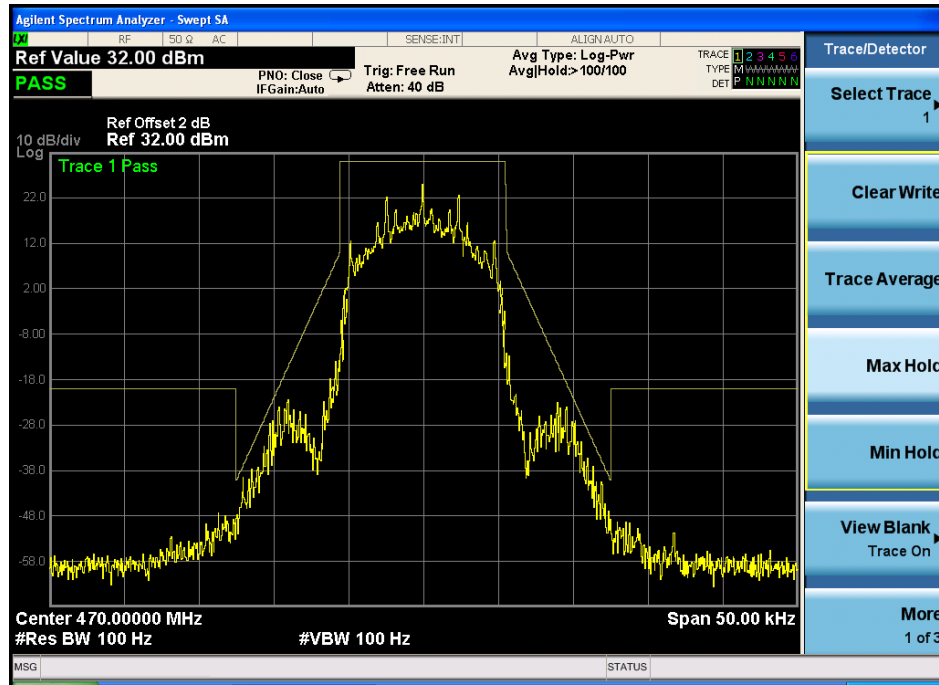

25KHz Channel Spacing:

Ch Low

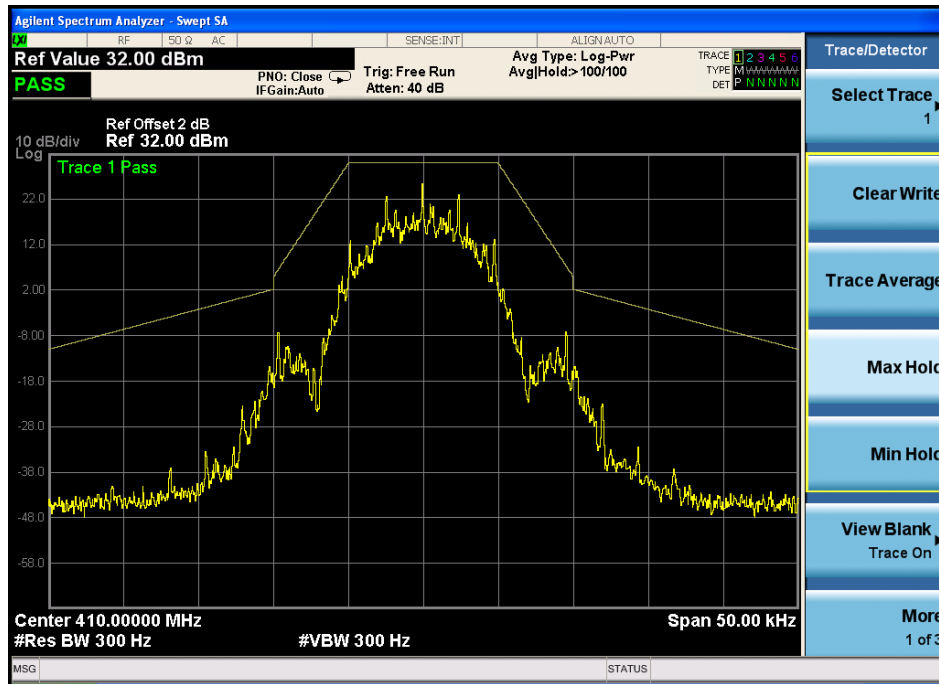

Ch Mid:

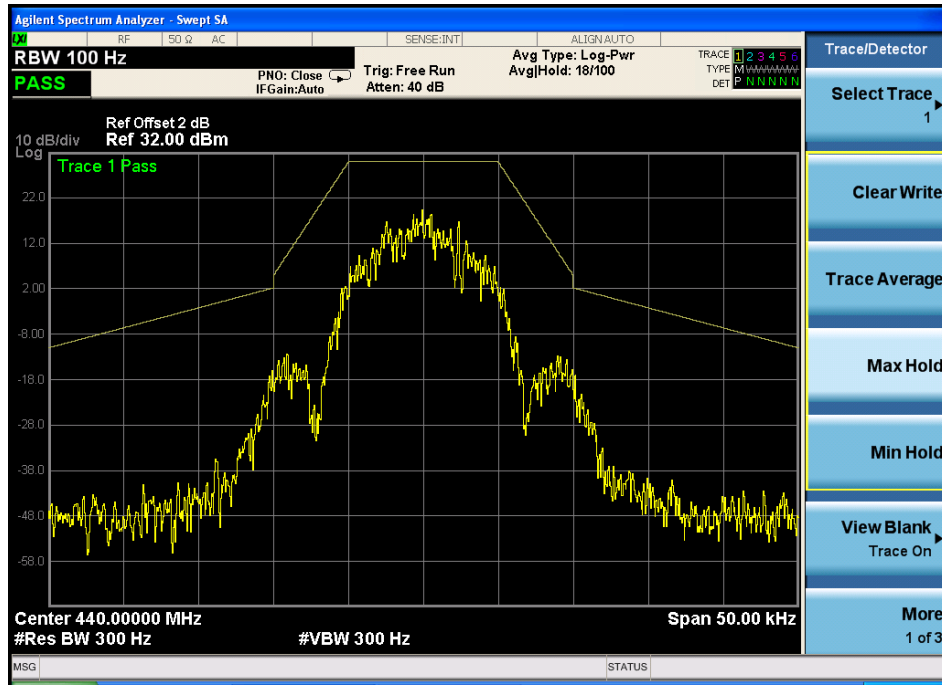

CH Hig:

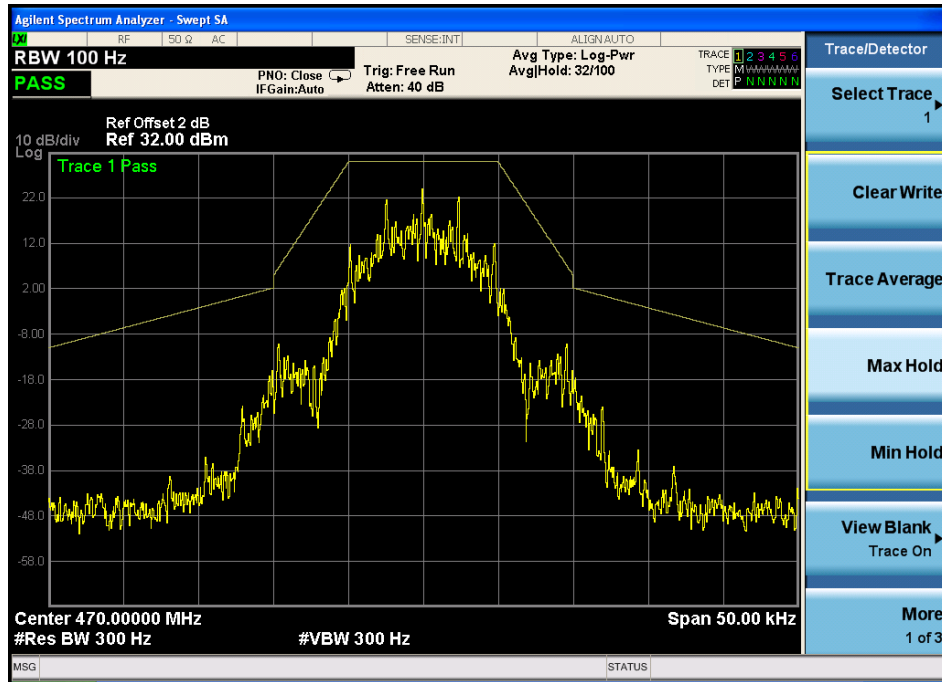

8 Spurious Emissions(conducted)

8.1 Test limit
FCC Part90.210& RSS-119 5.8.

8.2 Test Setup

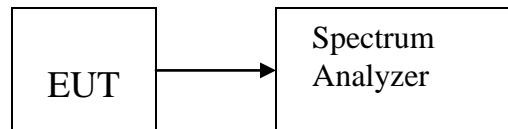

8.3 Test Result
PASS.
Detailed information please see the following page.

12.5KHz Channel Spacing:

Ch Low

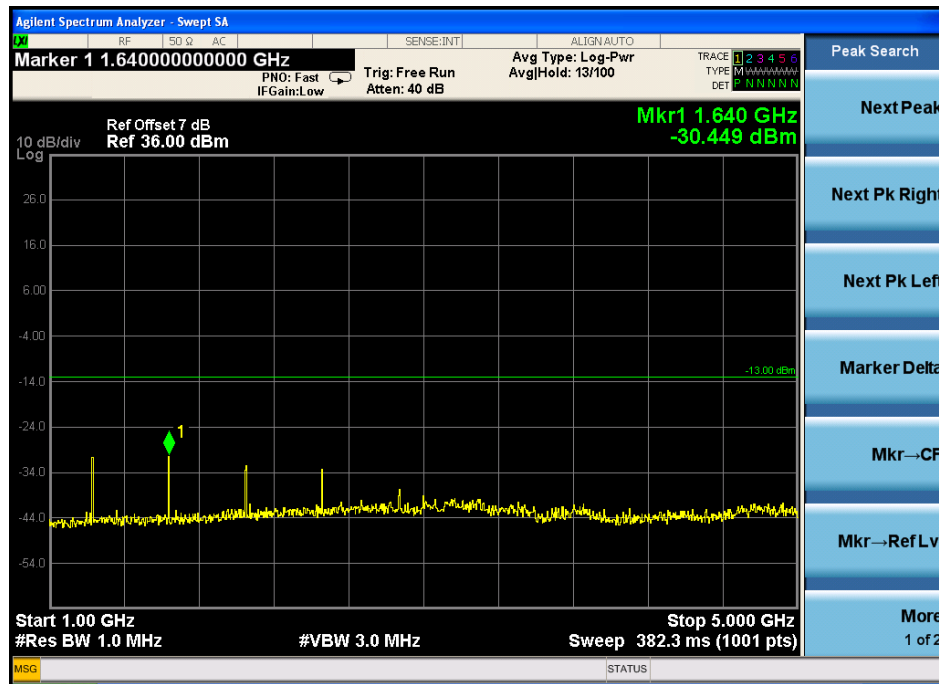
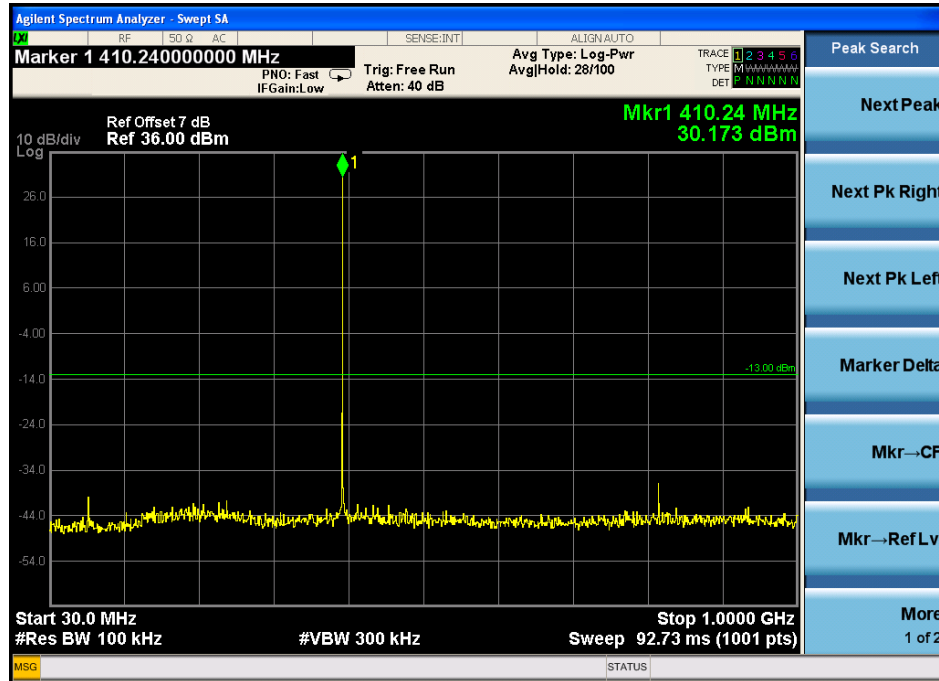

Ch Mid:

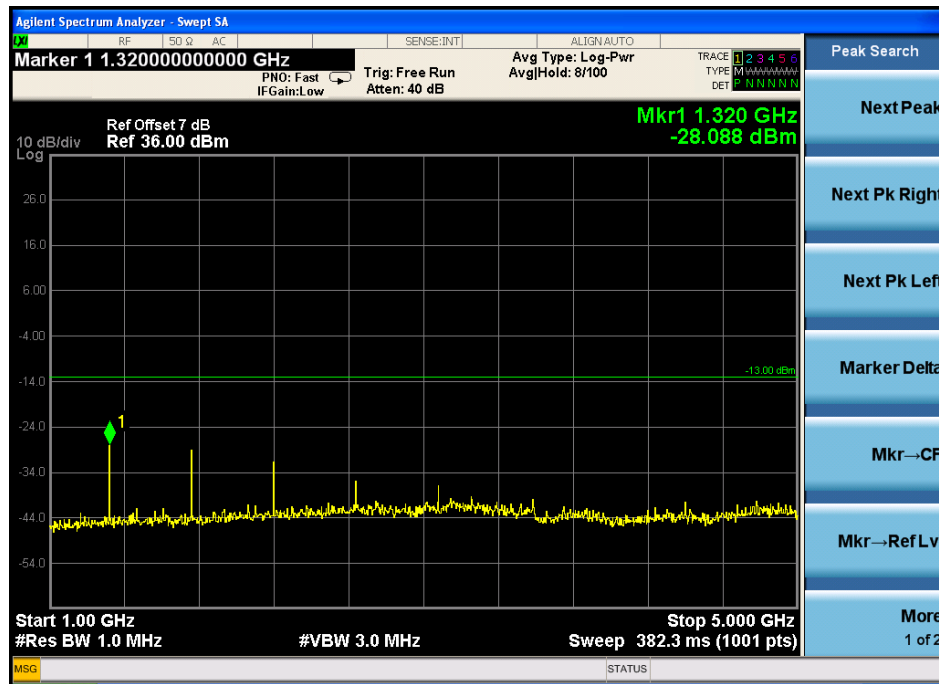
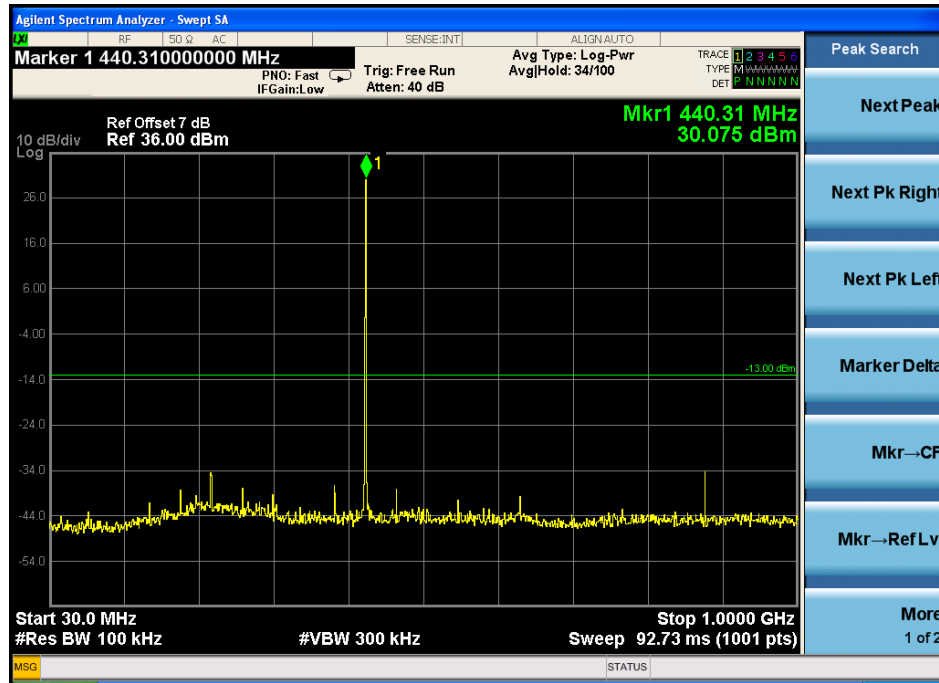

CH Hig:

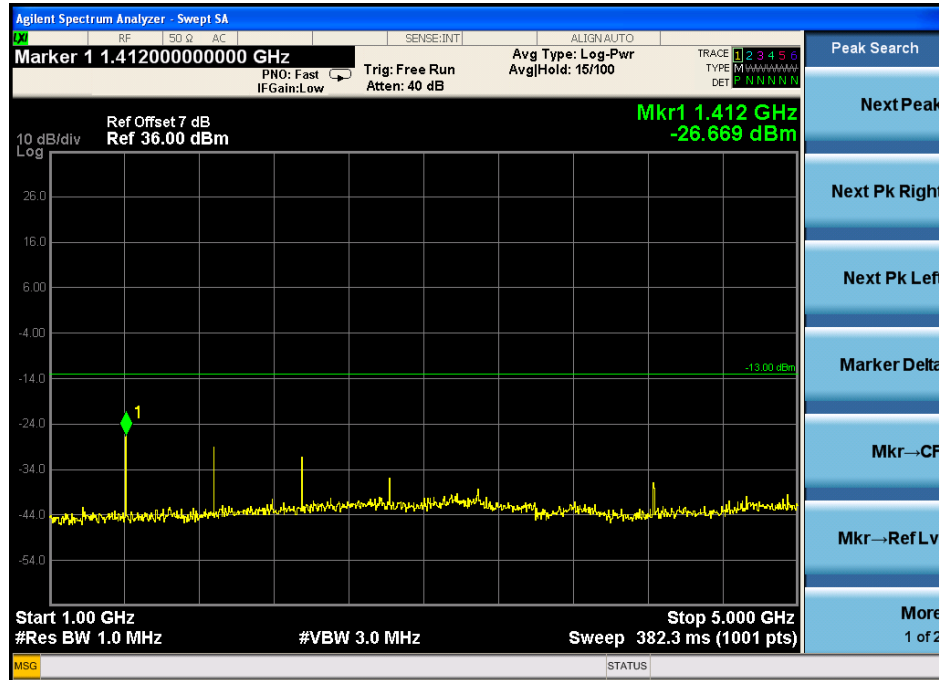
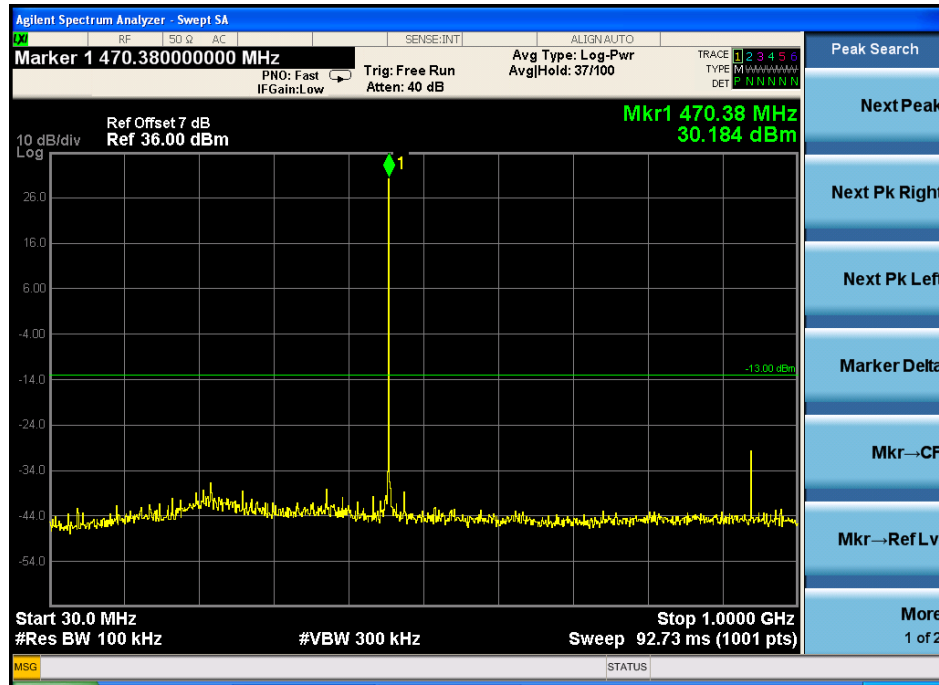

25KHz Channel Spacing:

Ch Low

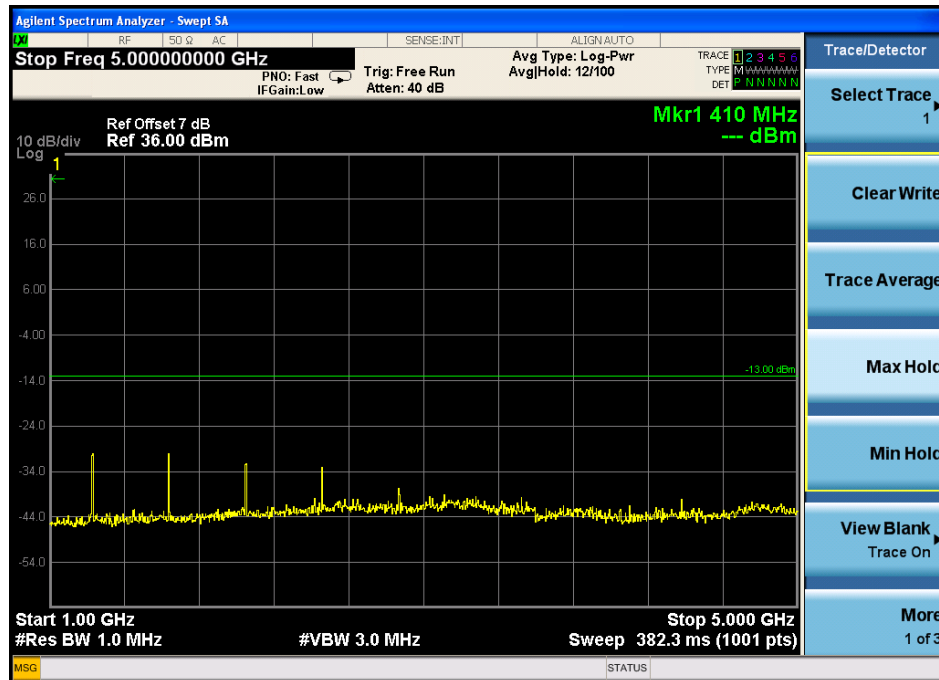
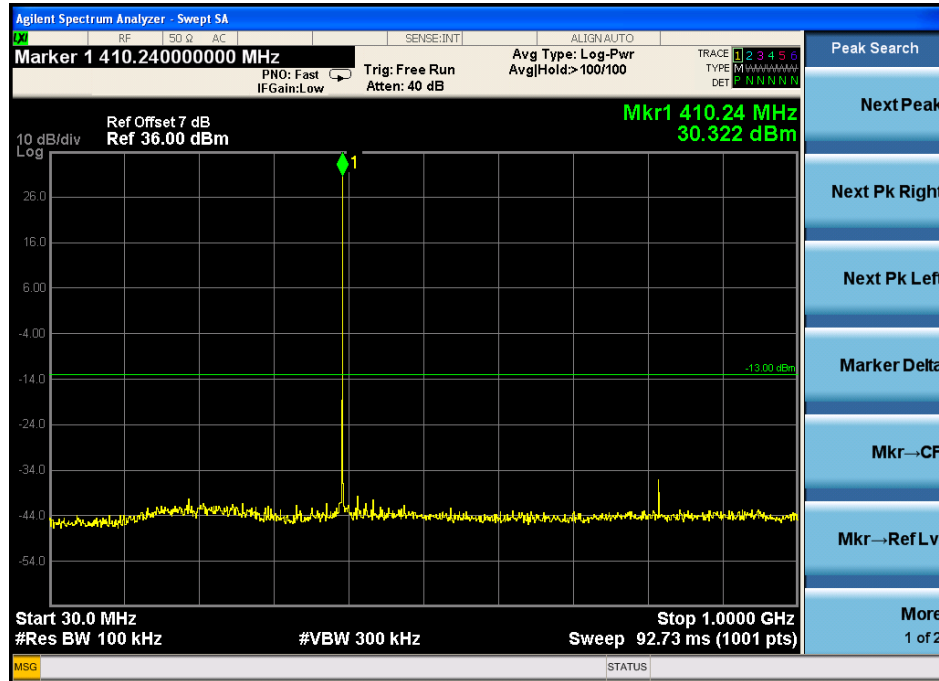

Ch Mid:

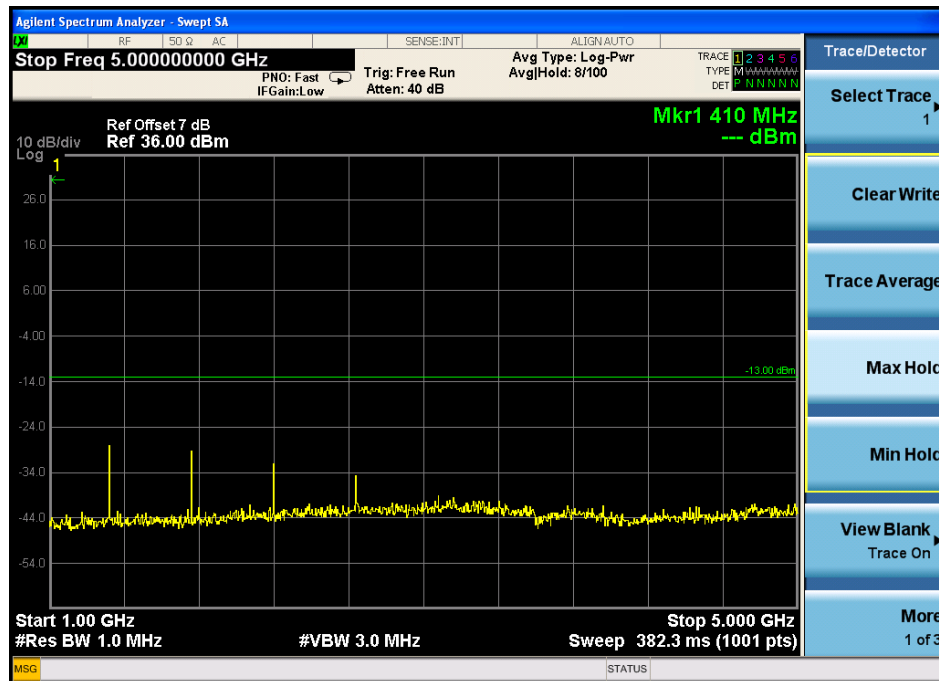
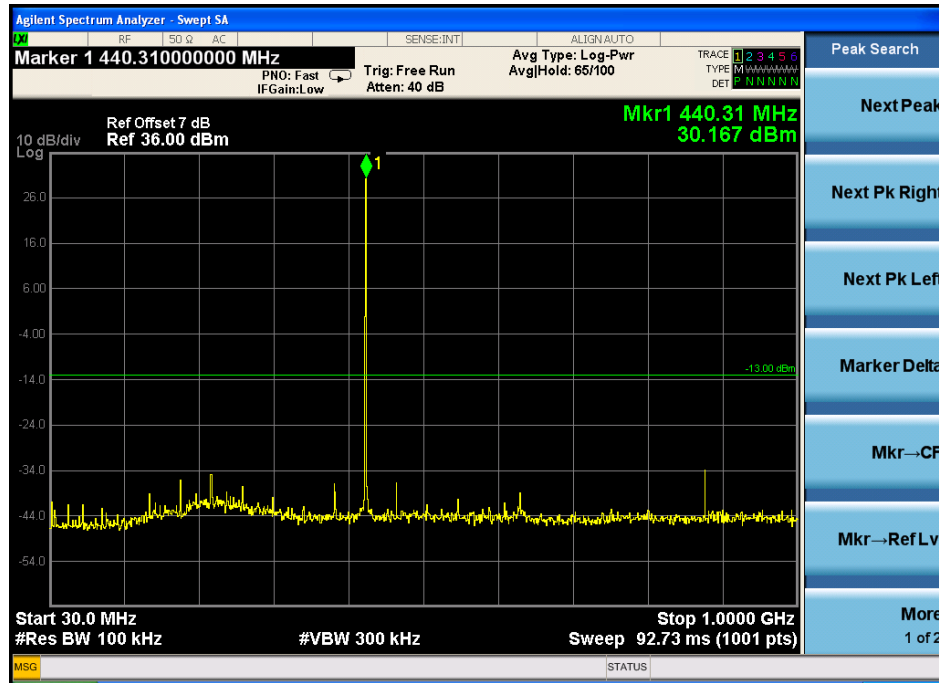

CH Hig:

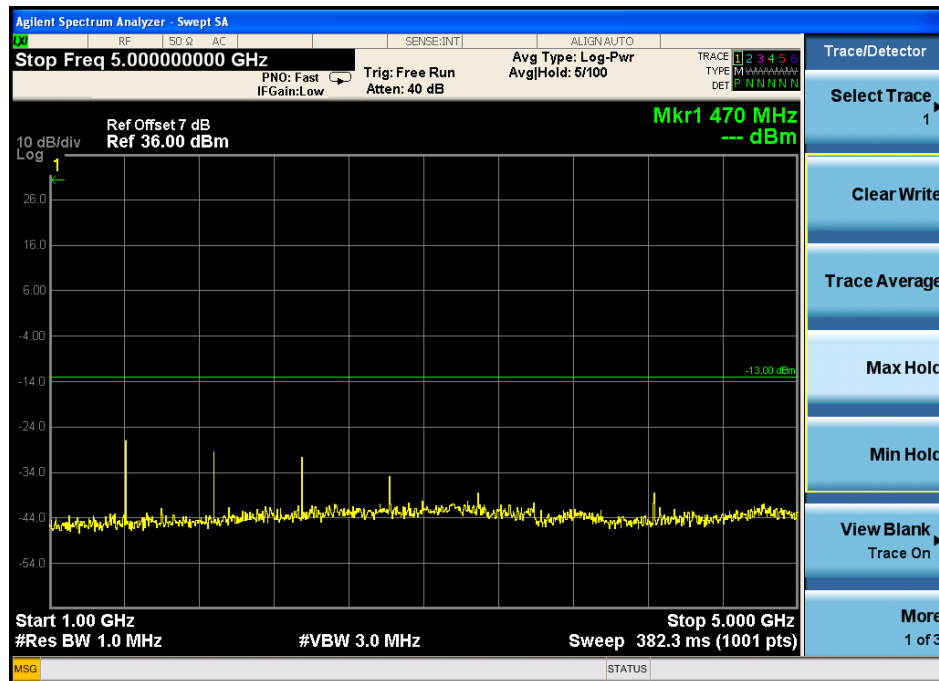
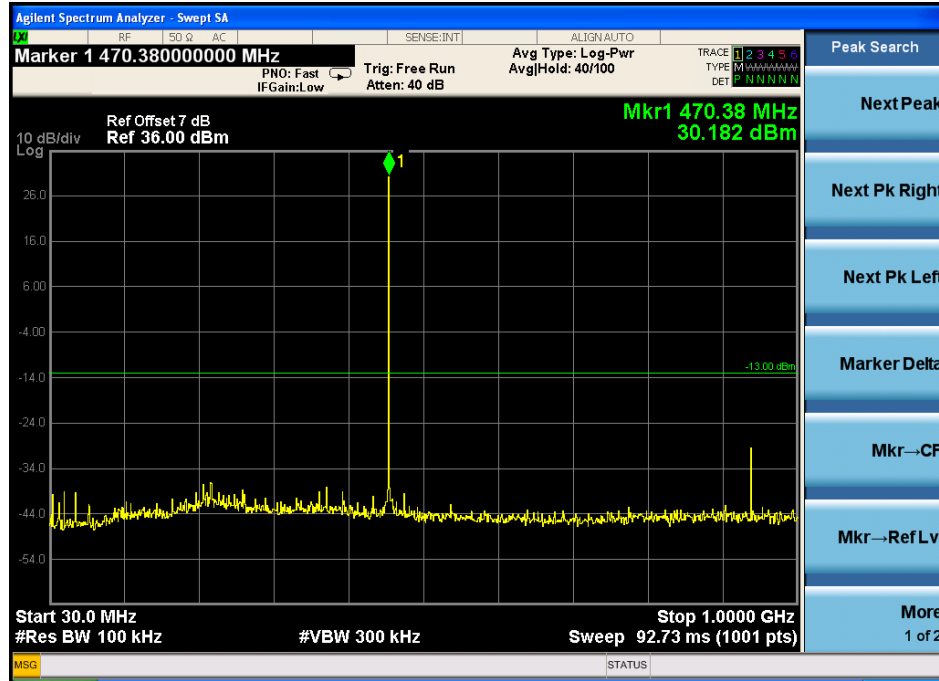

9 Radiation Emission Spurious Emissions(Radiated)

9.1 Radiation Emission Limits(90.210)

For equipment using 25 kHz channel spacing, on any frequency removed from the center of the authorized bandwidth by more than 250 percent of the authorized bandwidth: At least $43 + 10 \log(P)$ dB.

For equipment using 12.5 kHz channel spacing, on any frequency removed from the center of the authorized bandwidth by a displacement frequency (f_a in kHz) of more than 12.5 kHz: At least $50 + 10 \log(P)$ dB or 70 dB, whichever is the lesser attenuation.

9.1.1 Test Setup

See the next page

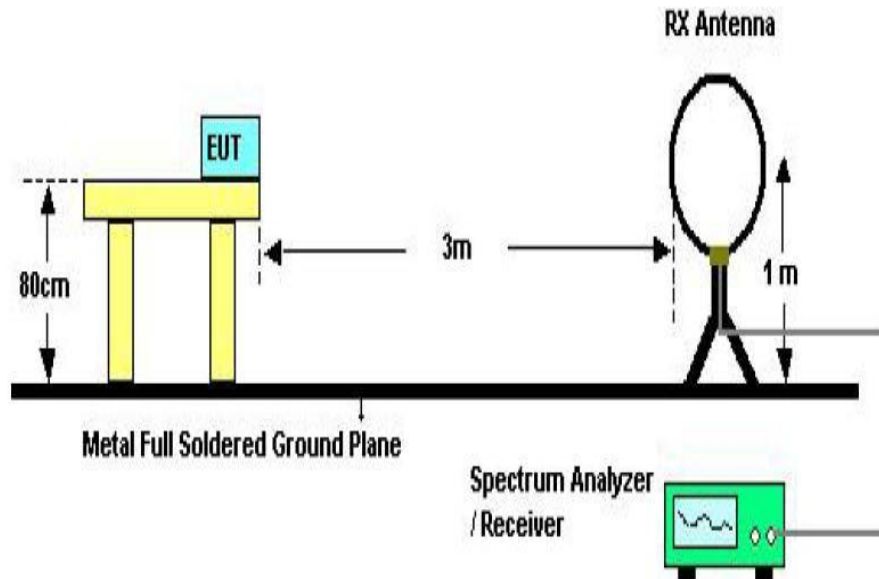

Below 30MHz Test Setup

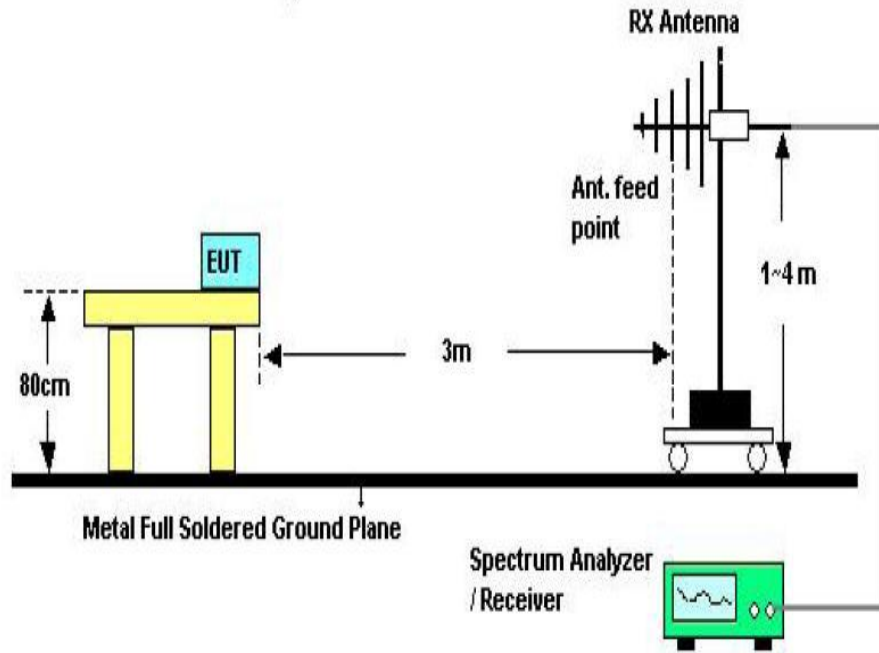

Above 30MHz Test Setup

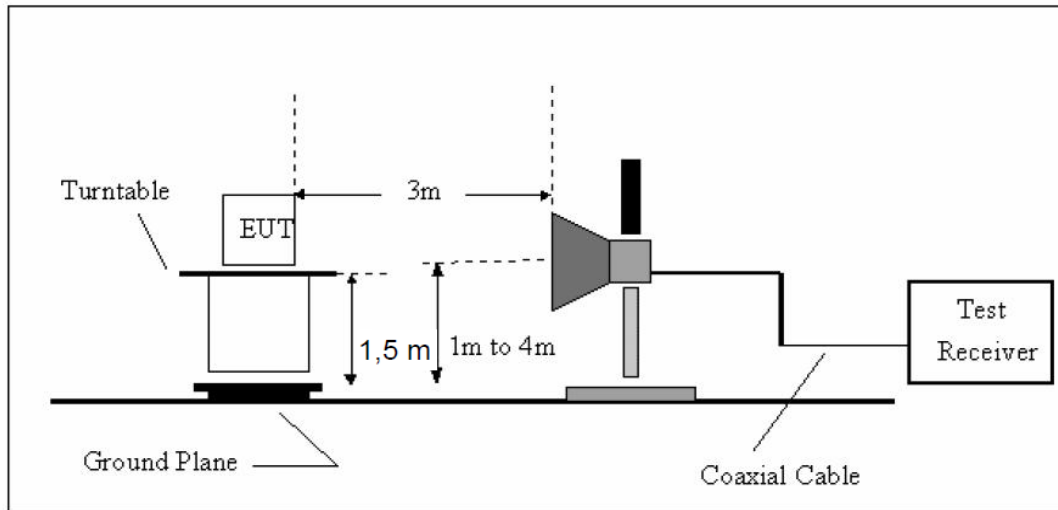

Above 1GHz Test Setup

9.1.2 Test Procedure

- a) The measuring distance of 3m shall be used for measurements at frequency up

to 1GHz and above 1GHz, The EUT was placed on a rotating 0.8 m high above ground for below 1GHz and 1.5m high for above1GHz testing, The table was rotated 360 degrees to determine the position of the highest radiation

- b) The Test antenna shall vary between 1m and 4m,Both Horizontal and Vertical antenna are set of make measurement.
- c) The initial step in collecting conducted emission data is a spectrum analyzer Peak detector mode pre-scanning the measurement frequency range. Significant Peaks are then marked. and then Qusia Peak Detector mode premeasured
- d) If Peak value comply with QP limit Below 1GHz.The EUT deemed to comply with QP limit. But the Peak value and average value both need to comply with applicable limit above 1GHz.
- e) For the actual test configuration, please see the test setup photo.

9.1.3 Test Equipment Setting For emission test Result

9KHz~150KHz	RBW 200Hz	VBW1KHz
150KHz~30MHz	RBW 9KHz	VBW 30KHz
30MHz~1GHz	RBW 120KHz	VBW 300KHz
Above 1GHz	RBW 1MHz	VBW 3MHz

9.1.4 Test Condition

Continual Transmitting in maximum power.

9.1.5 Test Result

We have scanned the 9KHz from 25GHz to the EUT.
Detailed information please see the following page.

From 9KHz to 30MHz: Conclusion: PASS

Note: The amplitude of spurious emissions which are attenuated by more than 20dB below the permissible value has no need to be reported.

EUT: Wireless Data Transceiver Module M/N: TRM101					
Power: DC 3.3V from power source					
Ambient Temperature: 23 °C			Relative Humidity: 60%		
Test result					
Test Mode: Low Channel, Channel Spacing 12.5KHz					
Frequency (MHz)	Antenna polarization	Result (dBm)	Limit (dBm)	Margin (dB)	Conclusion
532.43	H	-54.59	-20	34.59	PASS
820.0	H	-54.72	-20	34.72	PASS
1230.0	H	-39.49	-20	19.49	PASS
532.43	V	-55.39	-20	35.39	PASS
820.0	V	-53.47	-20	33.47	PASS
1230.0	V	-40.52	-20	20.52	PASS
Test Mode: Mid channel, Channel Spacing 12.5KHz					
532.43	H	-54.12	-20	34.12	PASS
880	H	-54.63	-20	34.63	PASS
1320	H	-42.35	-20	22.35	PASS
532.43	V	-53.24	-20	23.24	PASS
880	V	-51.19	-20	31.19	PASS
1320	V	-43.88	-20	23.88	PASS
Test Mode: High Channel, Channel Spacing 12.5KHz					
532.43	H	-51.39	-20	31.39	PASS
940	H	-49.45	-20	29.45	PASS
1410	H	-40.14	-20	20.14	PASS
532.43	V	-51.72	-20	31.72	PASS
940	V	-49.62	-20	29.62	PASS
1410	V	-39.82	-20	19.82	PASS
Note: All the emissions detected are belonging to narrowband emissions.					

EUT: Wireless Data Transceiver Module M/N: TRM101					
Power: DC 3.3V from power source					
Ambient Temperature: 23 °C			Relative Humidity: 60%		
Test result					
Test Mode: Low Channel, Channel Spacing 25KHz					
Frequency (MHz)	Antenna polarization	Result (dBm)	Limit (dBm)	Margin (dB)	Conclusion
532.43	H	-52.75	-13	39.75	PASS
820.0	H	-51.46	-13	38.46	PASS
1230.0	H	-37.39	-13	24.39	PASS
532.43	V	-53.24	-13	40.24	PASS
820.0	V	-51.44	-13	38.44	PASS
1230.0	V	-38.89	-13	25.89	PASS
Test Mode: Mid channel, Channel Spacing 25KHz					
532.43	H	-53.22	-13	40.22	PASS
880	H	-52.71	-13	39.71	PASS
1320	H	-41.63	-13	28.63	PASS
532.43	V	-52.49	-13	39.49	PASS
880	V	-50.53	-13	37.53	PASS
1320	V	-42.35	-13	29.35	PASS
Test Mode: High Channel, Channel Spacing 25KHz					
532.43	H	-50.27	-13	37.27	PASS
940	H	-48.16	-13	35.16	PASS
1410	H	-36.52	-13	23.2	PASS
532.43	V	-50.91	-13	37.91	PASS
940	V	-48.35	-13	35.35	PASS
1410	V	-37.44	-13	24.44	PASS

10 Transient Frequency Behavior

10.1 Test limit

FCC Part90.214& RSS-119 5.9.

10.2 Test Setup

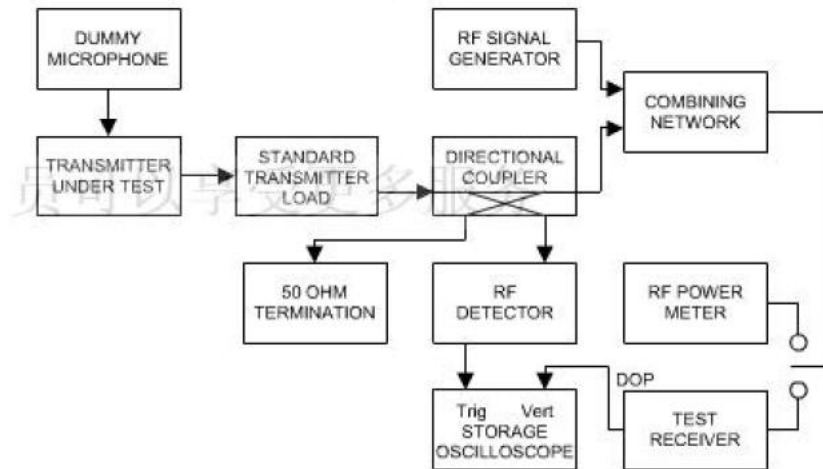

10.3 Test Procedure

The method of testing used was from TIA-603-D, section 2.2.19 Transient Frequency Behavior, sub-section 2.2.19.3 Method of Measurement (using a Modulation Domain Analyzer).

The output of the EUT was connected to a power meter in order to get a reference power measurement. And the reference level is -20dBm. Once the reference power measurement was determined, an external signal source was connected to the Modulation Domain Analyzer in order to set the trigger level.

The EUT was connected to the Modulation Domain Analyzer. In order to capture a single-shot turn-on of the transmitter signal, the modulation domain analyzer was set to trigger on the rising edge of the waveform. Plots were taken.

The modulation domain analyzer was then adjusted to trigger on the falling edge of the transmitter waveform in order to capture a single-shot turn-off transient of the transmitter signal. Plots were taken.

10.4 Test Result

PASS.

Detailed information please see the following page.

Test Plots for channel spacing 25KHz, EUT power setting:1W.

Power On

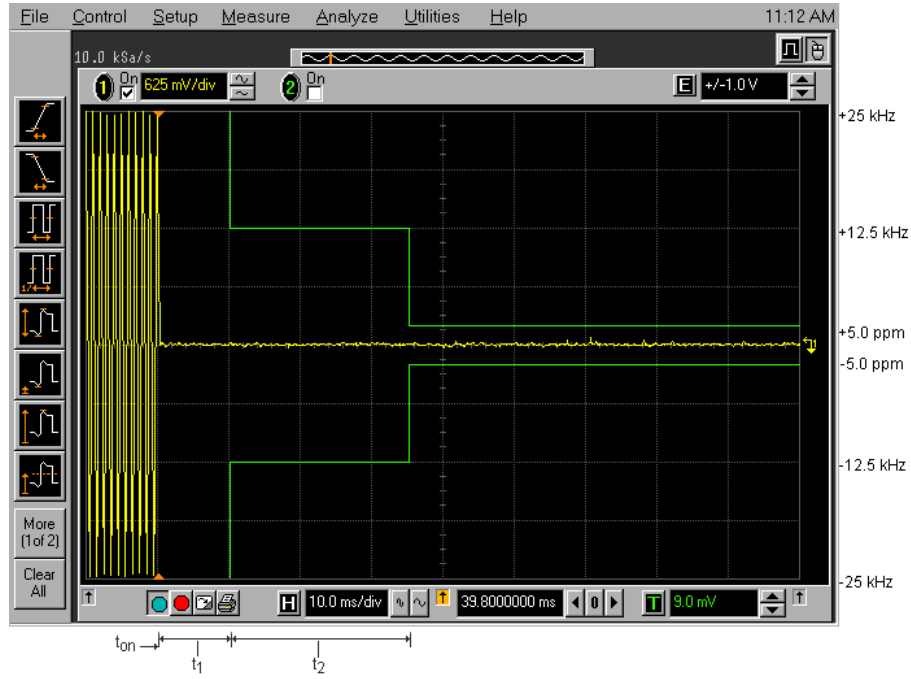

Power Off

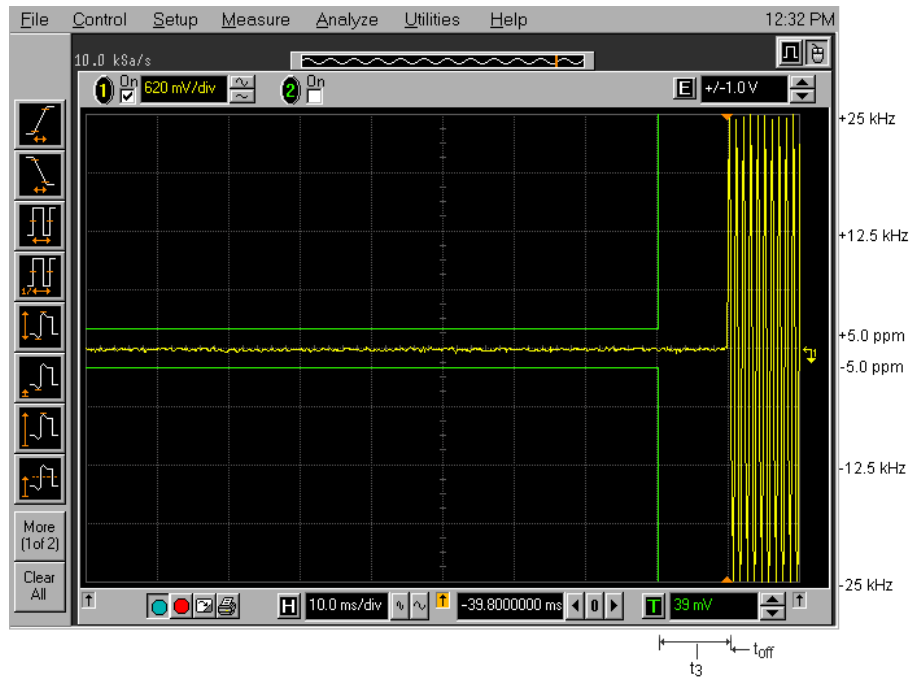

Test Plots for channel spacing 12.5KHz. EUT power setting:1W.

Power On

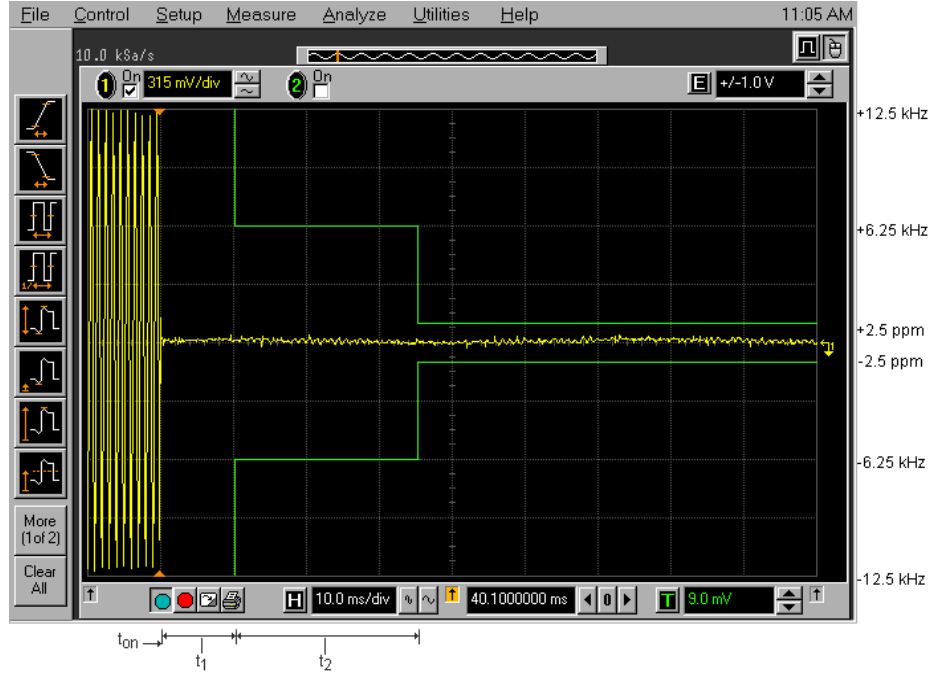

Power Off

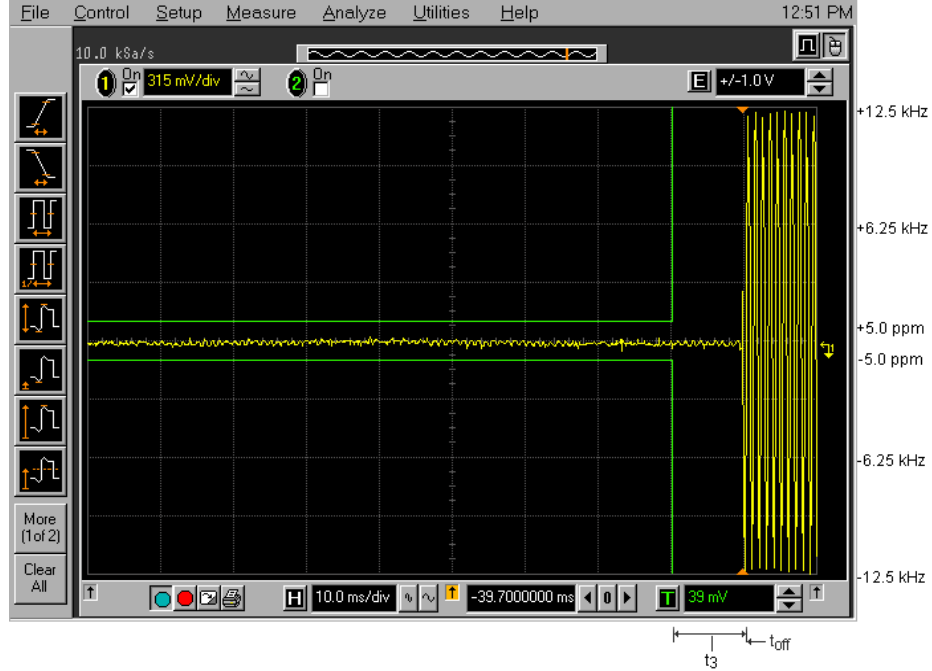

11 Behavior Frequency Stability

11.1 Standard Requirement

FCC Part90.213& RSS-119 5.3

11.2 Test Setup

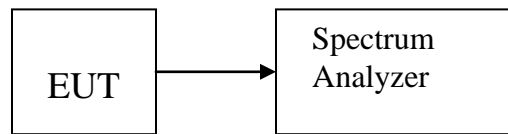

11.3 Test Result

PASS.

Detailed information please see the following page.

EUT: Wireless Data Transceiver Module M/N:TRM101			
Ambient Temperature:23°C		Relative Humidity: 60%	
Conclusion: PASS			
Mode	Voltage (V)	Frequency error (Hz)	frequency error (ppm)
Middle Channel 12.5KHz Channel Spacing	3.6V	-27	-0.06136
	3.5V	-27	-0.06136
	3.4V	-27	-0.06136
	3.3V	-27	-0.06136
Limit	1.5ppm		
Middle Channel 25KHz Channel Spacing	3.6V	-27	-0.06136
	3.5V	-27	-0.06136
	3.4V	-27	-0.06136
	3.3V	-27	-0.06136
Limit	2.5ppm		

Mode	Temperature (°C)	Frequency error (Hz)	frequency error (ppm)
Middle Channel 12.5KHz Channel Spacing	-30	-35	-0.07955
	-20	-27	-0.06136
	-10	-54	-0.12273
	0	-29	-0.06591
	10	-31	-0.07045
	20	-43	-0.09773
	30	-26	-0.05909
	40	-19	-0.04318
	50	-28	-0.06364
Limit	1.5ppm		
Middle Channel 25KHz Channel Spacing	-30	-31	-0.07045
	-20	-39	-0.08864
	-10	-29	-0.06591
	0	-29	-0.06591
	10	-31	-0.07045
	20	-33	-0.0750
	30	-28	-0.06364
	40	-26	-0.05909
	50	-22	-0.0500
Limit	2.5ppm		

12 Test setup photo

Photographs-Radiated Emission Test Setup in Chamber



13 Photos of EUT

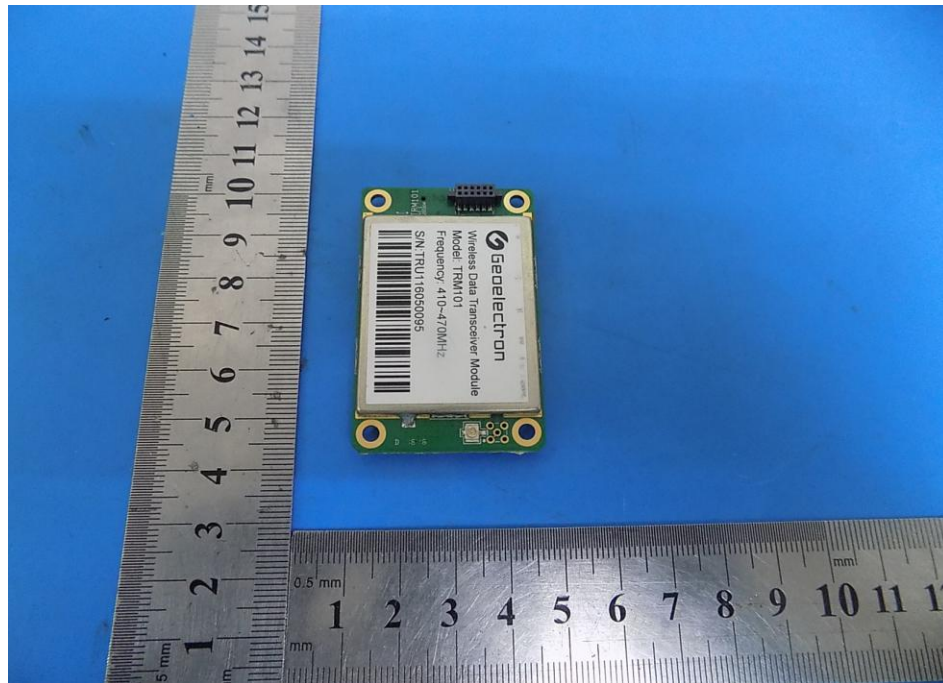

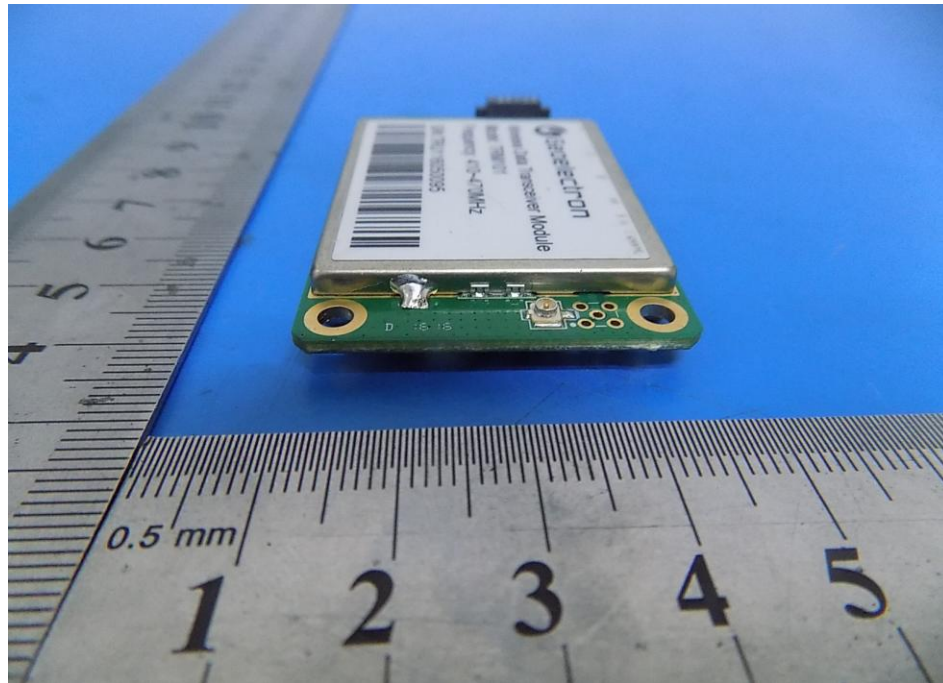
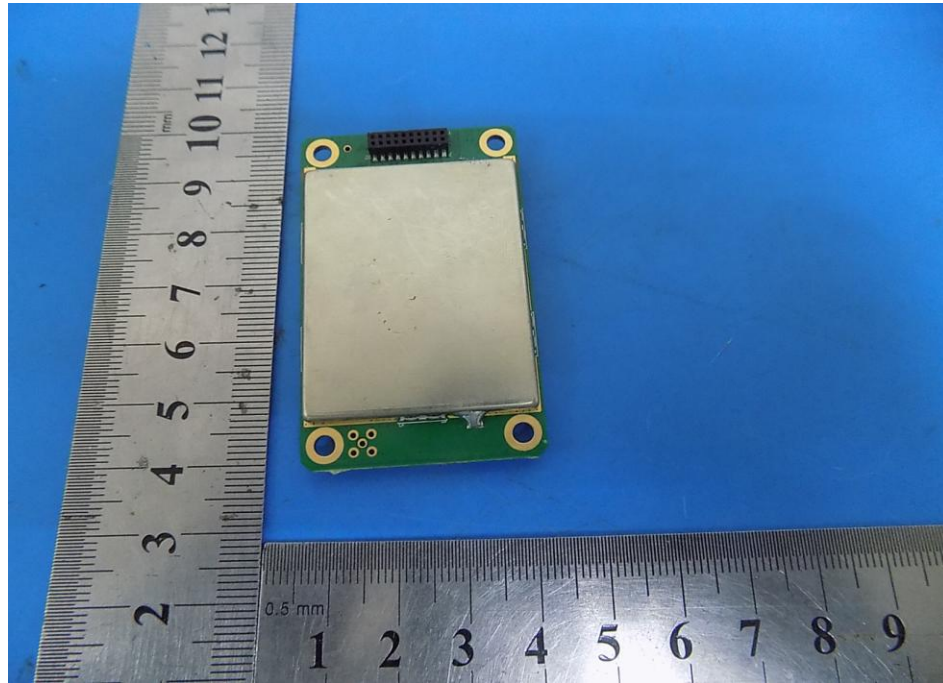

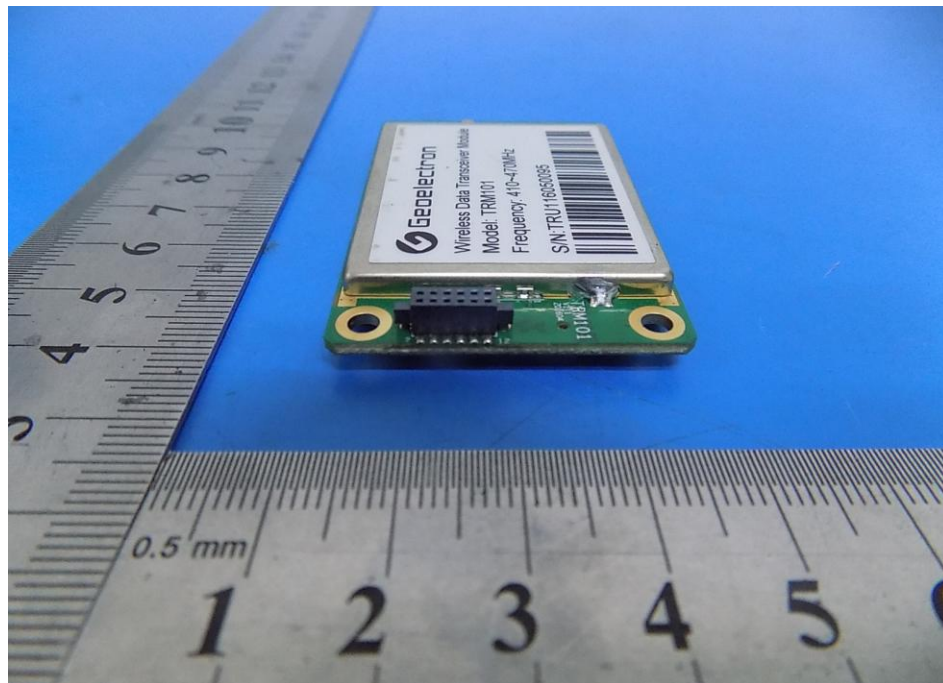
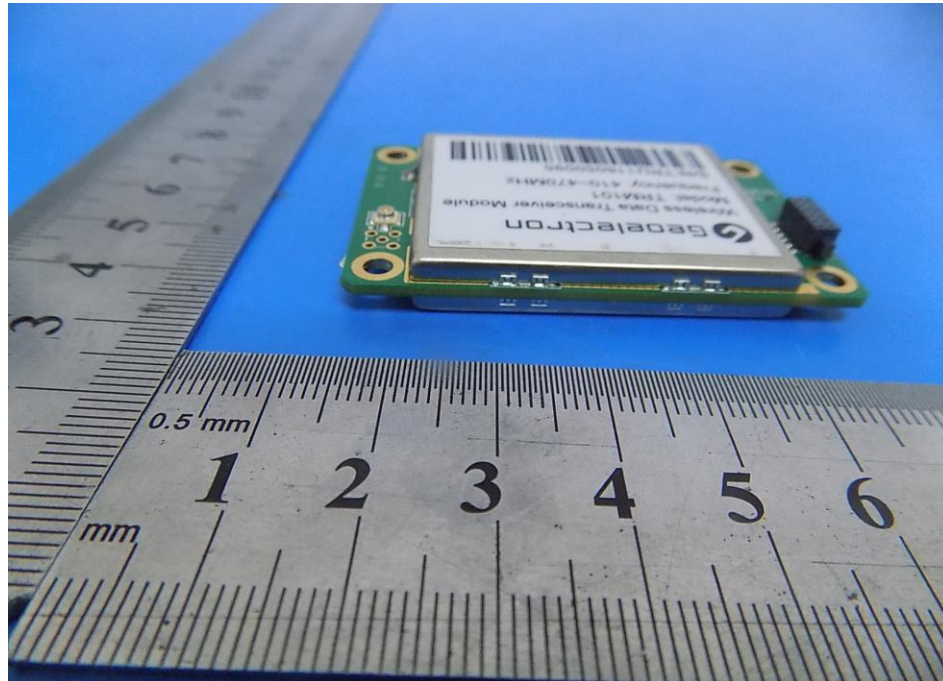

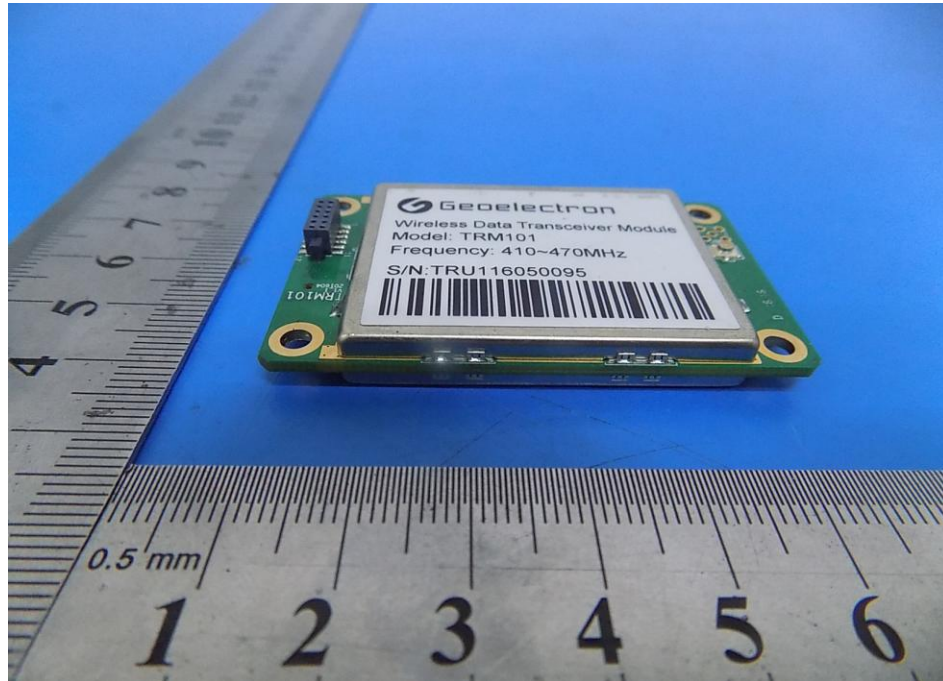

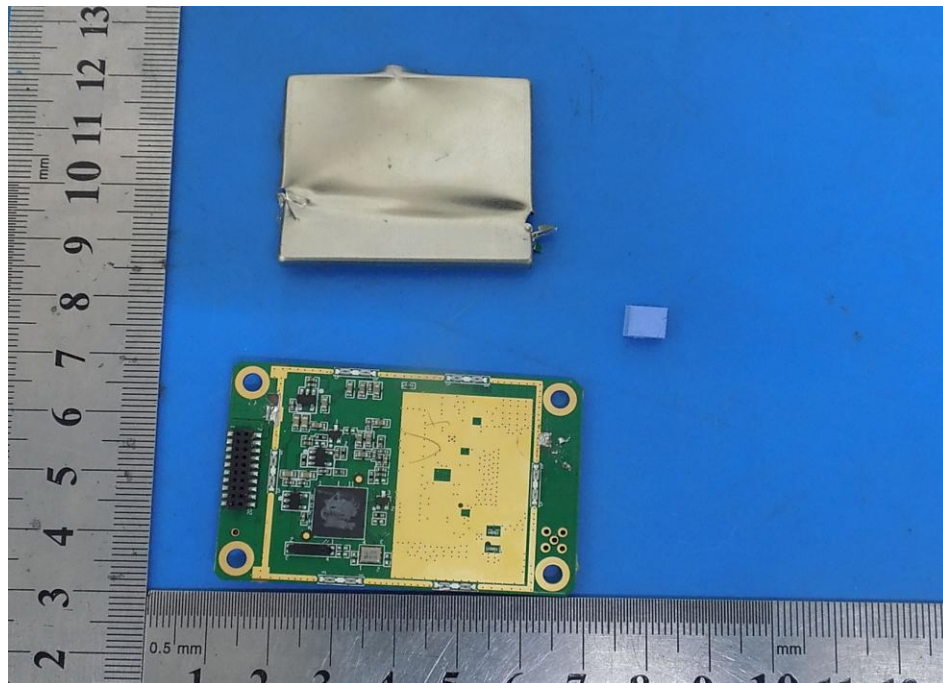
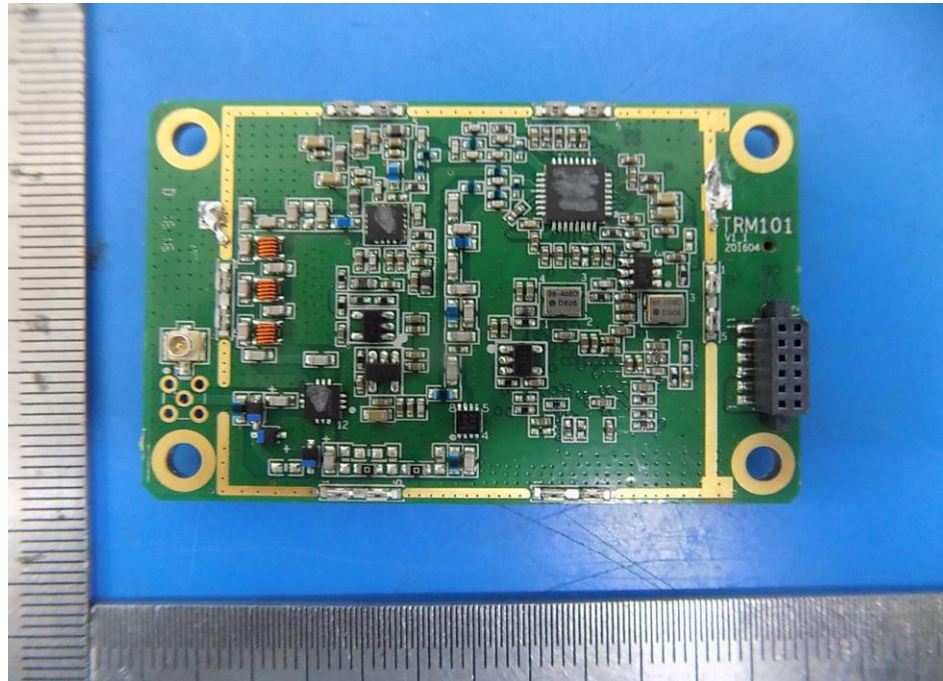

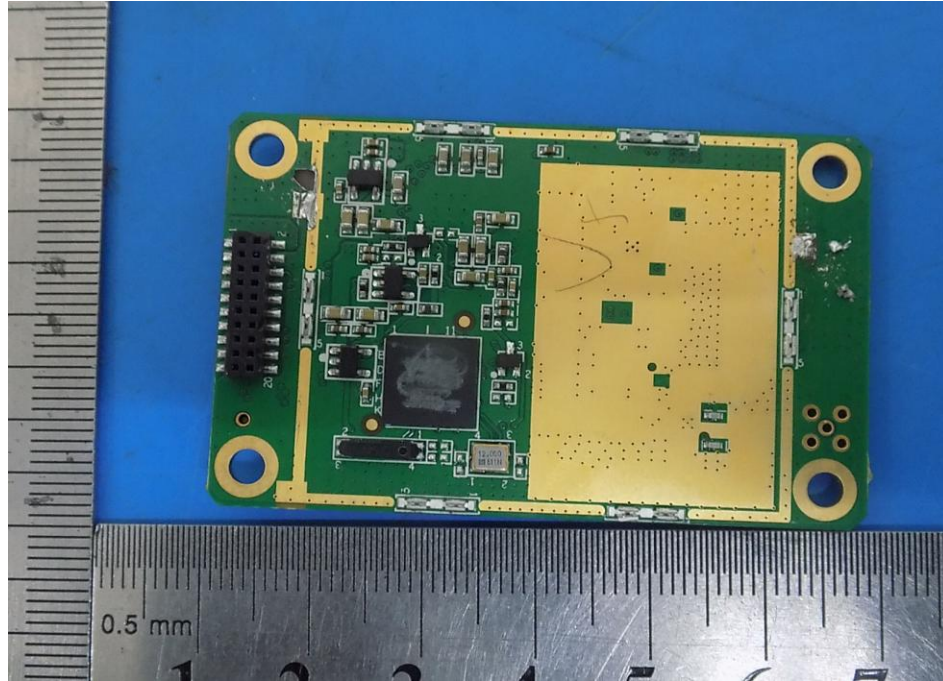

-----END OF THE REPORT-----