



## **FCC&IC TEST REPORT**

FCC ID: 2ABNA-P9IIHH, IC: 11648A-P9IIHH

**On Behalf of**

**Guangzhou Geoelectron Science & Technology Company  
Limited**

**P9II Handheld**

**Model No.: P9II PRO, P9II STD**

Prepared for : Guangzhou Geoelectron Science & Technology  
Company Limited  
Address : No.704, 7/F, Building C, No.7, Cai Pin Road, Science  
City, Luogang District, Guangzhou, China

Prepared By : Shenzhen Alpha Product Testing Co., Ltd.  
Address : Building i, No.2, Lixin Road, Fuyong Street, Bao'an  
District, 518103, Shenzhen, Guangdong, China

Report Number : T1881637 23  
Date of Receipt : October 23, 2018  
Date of Test : October 23, 2018- February 19, 2019  
Date of Report : February 20, 2019  
Version Number : REV0

## Contents

Page

<b>1</b>	<b>TEST SUMMARY .....</b>	<b>5</b>
<b>2</b>	<b>GENERAL INFORMATION .....</b>	<b>7</b>
2.1	GENERAL DESCRIPTION OF EUT .....	7
2.2	RELATED SUBMITTAL(S) / GRANT (S) .....	9
2.3	TEST FACILITY .....	9
2.4	MEASUREMENT UNCERTAINTY .....	9
<b>3</b>	<b>TEST INSTRUMENTS LIST .....</b>	<b>10</b>
<b>4</b>	<b>SYSTEM TEST CONFIGURATION .....</b>	<b>11</b>
4.1	TEST MODE .....	11
4.2	CONFIGURATION OF TESTED SYSTEM .....	12
4.3	CONDUCTED AV OUTPUT POWER .....	13
4.4	PEAK-TO-AVERAGE RATIO .....	15
4.5	OCCUPY BANDWIDTH .....	20
4.6	MODULATION CHARACTERISTIC .....	28
4.7	OUT OF BAND EMISSION AT ANTENNA TERMINALS .....	28
4.8	ERP, EIRP MEASUREMENT .....	41
4.9	FIELD STRENGTH OF SPURIOUS RADIATION MEASUREMENT .....	52
4.10	FREQUENCY STABILITY V.S. TEMPERATURE MEASUREMENT .....	63
4.11	FREQUENCY STABILITY V.S. VOLTAGE MEASUREMENT .....	67

## TEST REPORT DECLARATION

Applicant : Guangzhou Geoelectron Science & Technology Company Limited

Address : No.704, 7/F, Building C, No.7, Cai Pin Road, Science City,  
Luogang District, Guangzhou, China

Manufacturer : Guangzhou Geoelectron Science & Technology Company Limited

Address : No.704, 7/F, Building C, No.7, Cai Pin Road, Science City,  
Luogang District, Guangzhou, China

EUT Description : P9II Handheld

(A) Model No. : P9II PRO, P9II STD

(B) Trademark : N/A

**Measurement Standard Used:**

**FCC CFR Title 47 Part 2**  
**FCC CFR Title 47 Part22 Subpart H**  
**FCC CFR Title 47 Part24 Subpart E**  
**FCC CFR Title 47 Part27 Subpart C**  
**RSS-132 Issue 3 January 2013**  
**RSS-133 Issue 6 January 2018**  
**RSS-139 Issue 3, July 2015**  
**RSS-Gen Issue 5, April 2018**  
**ANSIC 63.26:2015, TIA/EIA-603-D:2010**

The device described above is tested by Shenzhen Alpha Product Testing Co., Ltd. to determine the maximum emission levels emanating from the device. The test results are contained in this test report and Shenzhen Alpha Product Testing Co., Ltd. is assumed of full responsibility for the accuracy and completeness of these tests.

After the test, our opinion is that EUT compliance with the requirement of the above standards.

This report applies to above tested sample only. This report shall not be reproduced in parts without written approval of Shenzhen Alpha Product Testing Co., Ltd.

Tested by (name + signature).....: Reak Yang  
Project Engineer

*Reak Yang*  
.....

Approved by (name + signature).....: Simple Guan  
Project Manager

*Simple Guan*  
.....

Date of issue.....: February 20, 2019

**Revision History**

Revision	Issue Date	Revisions	Revised By
00	February 20, 2019	Initial released Issue	Simple Guan

## 1 Test Summary

Test Item	Section in CFR 47	Result
RF Exposure (SAR)	Part 1.1307 Part 2.1093 RSS-102 Issue 5	Pass* (Please refer to SAR Report)
RF Output Power	Part 2.1046 Part 22.913 (a)(2) Part 24.232 (c) Part 27.50(d)(4) RSS-132 Issue 3, January 2013(5.4) RSS-133 Issue 6, January 2018(4.1) RSS-139 Issue 3, January 2015(4.1)	Pass
Peak-to-Average Ratio	Part 2.1046 Part 22.913(d) Part 24.232 (d) Part 27.50(d)(5) RSS-132 Issue 3, January 2013(5.4) RSS-133 Issue 6, January 2018(6.4) RSS-139 Issue 3, January 2015(6.5)	Pass
Modulation Characteristics	Part 2.1047 RSS-132 Issue 3, January 2013(5.2) RSS-133 Issue 6, January 2018(6.2) RSS-139 Issue 3, January 2015(6.2)	Pass
99% & -26 dB Occupied Bandwidth	Part 2.1049 Part 22.917 Part 24.238 Part 27.53(h) RSS-132 Issue 3, January 2013(3.1) RSS-133 Issue 6, January 2018(2.3) RSS-139 Issue 3, January 2015(2.3)	Pass
Spurious Emissions at Antenna Terminal	Part 2.1051 Part 22.917 (a) Part 24.238 (a) Part 27.53(h) RSS-132 Issue 3, January 2013(5.5) RSS-133 Issue 6, January 2018(6.5) RSS-139 Issue 3, January 2015(6.6)	Pass
Field Strength of Spurious Radiation	Part 2.1053 Part 22.917 (a) Part 24.238 (a) Part 27.53(h) RSS-132 Issue 3, January 2013(5.5) RSS-133 Issue 6, January 2018(6.5) RSS-139 Issue 3, January 2015(6.6)	Pass
Out of band emission, Band Edge	Part 22.917 (a) Part 24.238 (a) Part 27.53(h) RSS-132 Issue 3, January 2013(5.5) RSS-133 Issue 6, January 2018(6.5) RSS-139 Issue 3, January 2015(6.6)	Pass
Frequency stability vs. temperature	Part 2.1055(a)(1)(b) Part 22.355, Part 24.235, Part 27.54 RSS-132 Issue 3, January 2013(5.3) RSS-133 Issue 6, January 2018(6.3) RSS-139 Issue 3, January 2015(6.4)	Pass

Frequency stability vs. voltage	Part 2.1055(d)(1)(2) Part 22.355, Part 24.235, Part 27.54 RSS-132 Issue 3, January 2013(5.3) RSS-133 Issue 6, January 2018(6.3) RSS-139 Issue 3, January 2015(6.4)	Pass
---------------------------------	--	------

*Pass: The EUT complies with the essential requirements in the standard.*

## 2 General Information

### 2.1 General Description of EUT

Description/PMN	: P9II Handheld
Model Number/HVIN(s)	: P9II PRO, P9II STD
Diff	: They are all the same, except that P9II PRO with M8T GPS receiver, P9II STD without M8T GPS receiver, the result of this report belongs to P9II PRO.
Trademark	: N/A
Test Voltage	: DC 7.2V from battery, DC 15V For Charging
Support Networks	GPRS, EGPRS, WCDMA
Support Bands	GSM850, PCS1900, WCDMA Band V, WCDMA Band IV, WCDMA Band II
TX Frequency	GSM850: 824.20MHz-848.80MHz PCS1900: 1850.20MHz-1909.80MHz WCDMA Band V: 826.40MHz -846.60MHz WCDMA Band IV: 1712.60MHz -1752.40MHz WCDMA Band II: 1852.40MHz -1907.60MHz
GPRS Class	12
EGPRS Class	12
Modulation type	GPRS: GMSK EGPRS: GMSK/8PSK WCDMA Band II/IV/V: QPSK
Antenna type	Internal antenna
Antenna gain	Internal Antenna, Maximum Gain is -0.72dBi for GSM Internal Antenna, Maximum Gain is -0.72dBi for WCDMA
Software version	: V1.0
Hardware version/FVIN	: V1.3

Remark: The worst-case simultaneous transmission configuration was evaluated with no non-compliance found. Results in this report are only for 2G and 3G function, and there is no other transmitter involved.

**Operation Frequency List:**

GSM 850		PCS1900		WCDMA Band V		WCDMA Band II	
Channel	Frequency (MHz)	Channel	Frequency (MHz)	Channel	Frequency (MHz)	Channel	Frequency (MHz)
128	824.20	512	1850.20	4132	826.40	9262	1852.40
129	824.40	513	1850.40	4133	826.60	9263	1852.60
·	·	·	·	·	·	·	·
189	836.40	660	1879.80	4181	836.20	9399	1879.80
190	836.60	661	1880.00	4182	836.40	9400	1880.00
191	836.80	662	1880.20	4183	836.60	9401	1880.20
·	·	·	·	·	·	·	·
250	848.60	809	1909.60	4232	846.40	9537	1907.40
251	848.80	810	1909.80	4233	846.60	9538	1907.60

WCDMA Band IV					
Channel	Frequency (MHz)	Channel	Frequency (MHz)	Channel	Frequency (MHz)
1313	1712.60	...	...	...	...
1314	1712.80	1412	1732.60	1510	1752.00
1315	1713.00	1413	1732.80	1511	1752.20
...	...	...	...	1512	1752.40

Regards to the operating frequency range over 10 MHz, the Lowest frequency, the middle frequency, and the highest frequency of channel were selected to perform the test, and the selected channel see below:

**Final test channel:**

GSM 850		PCS1900		WCDMA Band II		WCDMA Band V		WCDMA Band IV	
Channel	Frequency (MHz)	Channel	Frequency (MHz)	Channel	Frequency (MHz)	Channel	Frequency (MHz)	Channel	Frequency (MHz)
128	824.20	512	1850.20	9262	1852.40	4132	826.40	1313	1712.60
190	836.60	661	1880.00	9400	1880.00	4183	836.60	1413	1732.60
251	848.80	810	1909.80	9538	1907.60	4233	846.60	1512	1752.40



## 2.2 Related Submittal(s) / Grant (s)

This submittal(s) (test report) is filing to comply with Section Part 2, Part 22 subpart H, Part 24 subpart E, Part 27 subpart C of the FCC CFR 47, RSS-Gen, RSS-132, RSS-133, RSS-139 Rules, KDB 971168 D01 v03r01, ANSI C63.26 and TIA/EIA-603-D.

## 2.3 Test Facility

Shenzhen Alpha Product Testing Co., Ltd  
Building i, No.2, Lixin Road, Fuyong Street, Bao'an District, 518103, Shenzhen, Guangdong, China

June 21, 2018 File on Federal Communication Commission

Registration Number: 293961

Designation Number: CN1236

July 25, 2017 Certificated by IC

Registration Number: 12135A

## 2.4 Measurement Uncertainty

Item	Uncertainty
Uncertainty for Power point Conducted Emissions Test	2.74dB
Uncertainty for Radiation Emission test in 3m chamber (below 30MHz)	2.13 dB(Polarize: V)
	2.57dB(Polarize: H)
Uncertainty for Radiation Emission test in 3m chamber (30MHz to 1GHz)	3.77dB(Polarize: V)
	3.80dB(Polarize: H)
Uncertainty for Radiation Emission test in 3m chamber (1GHz to 25GHz)	4.16dB(Polarize: H)
	4.13dB(Polarize: V)
Uncertainty for radio frequency	$5.4 \times 10^{-8}$
Uncertainty for conducted RF Power	0.37dB
Uncertainty for temperature	0.2°C
Uncertainty for humidity	1%
Uncertainty for DC and low frequency voltages	0.06%

### 3 Test Instruments list

Equipment	Manufacturer	Model No.	Serial No.	Last cal.	Cal Interval
Bilog Antenna	Schwarzbeck	VULB 9168	VULB9168-438	2018.04.13	2Year
Horn Antenna	SCHWARZBECK	BBHA 9120 D	BBHA 9120 D(1201)	2018.04.13	2Year
Loop Antenna	SCHWARZBECK	FMZB 1519B	00059	2018.09.26	2Year
Filter	KANGMAI	ZLPP-LDC-1000-1959	1209002075	2018.09.21	1Year
Filter	WAINWRIGHT	WHKX2.80 /18G-12SS	SN1	2018.09.21	1Year
Filter	WAINWRIGHT	WHKX1.0G/15 G-10SS	SN40	2018.09.21	1Year
RF Cable	Resenberger	Cable 4	N/A	2018.09.21	1Year
CMU200	ROHDE&SCHWARZ	CMU200	116785	2018.09.11	1Year
CMW500	ROHDE&SCHWARZ	CMW500	1201.0002K50-117239-sM	2018.09.21	1Year
Signal Analyzer	Agilent	N9020A	MY499100060	2018.09.11	1Year
vector Signal Generator	Agilent	N5182A	MY49060042	2018.09.11	1Year
vector Signal Generator	Agilent	E4438C	US44271917	2018.09.11	1Year
Amplifier	Agilent	8449B	3008A02664	2018.09.21	1Year
Test Receiver	ROHDE&SCHWARZ	ESR	1316.3003K03-102082-Wa	2018.09.21	1Year
9*6*6 anechoic	CHENYU	9*6*6	N/A	/	/
RF Cable	Resenberger	Cable 1	N/A	2018.09.21	1Year
RF Cable	Resenberger	Cable 2	N/A	2018.09.21	1Year
RF Cable	Resenberger	Cable 3	N/A	2018.09.21	1Year
Power Sensor	Power Radio	RPR3006W	15100041SNO91	2018.09.21	1Year
20dB Attenuator	ICPROBING	IATS1	82347	2018.09.21	1Year
L.I.S.N.#1	SCHWARZBECK	NSLK8126	8126-466	2018.09.21	1Year
L.I.S.N.#2	ROHDE&SCHWARZ	ENV216	101043	2018.09.21	1Year
POWER DIVIDER	Mini-circuits	PD-2SF-0010	N/A	2018.09.21	1Year
POWER DIVIDER	Mini-circuits	PD-2SF-0010	N/A	2018.09.21	1Year
Temperature& Humidity test chamber	GZGONGWEN	GDS-250	080821	2018.09.11	1Year
Horn Antenna	SCHWARZBECK	BBHA 9120 D	BBHA 9120 D(1207)	2018.04.13	2Year
Bilog Antenna	Schwarzbeck	VULB 9168	VULB9168-627	2018.09.24	2Year

## 4 System test configuration

### 4.1 Test mode

During all testing, EUT is in link mode with base station emulator at maximum power level. The spurious emission measurements were carried out in semi-anechoic chamber with 3-meter test range, and EUT is rotated on three test planes to find out the worst emission.

Test modes		
Band	Radiated	Conducted
<b>GSM 850</b>	<ul style="list-style-type: none"> <li>■ GSM 1 link</li> <li>■ GPRS 1 link</li> <li>■ EPRS 1 link</li> </ul>	<ul style="list-style-type: none"> <li>■ GSM 1 link</li> <li>■ GPRS 1 link</li> <li>■ EGPRS 1 link</li> </ul>
<b>PCS 1900</b>	<ul style="list-style-type: none"> <li>■ GSM 1 link</li> <li>■ GPRS 1 link</li> <li>■ EGPRS 1 link</li> </ul>	<ul style="list-style-type: none"> <li>■ GSM 1 link</li> <li>■ GPRS 1 link</li> <li>■ EGPRS 1 link</li> </ul>
<b>WCDMA II</b>	<ul style="list-style-type: none"> <li>■ RMC 12.2Kbps link</li> </ul>	<ul style="list-style-type: none"> <li>■ RMC 12.2Kbps link</li> </ul>
<b>WCDMA Band V</b>	<ul style="list-style-type: none"> <li>■ RMC 12.2Kbps link</li> </ul>	<ul style="list-style-type: none"> <li>■ RMC 12.2Kbps link</li> </ul>
<b>WCDMA IV</b>	<ul style="list-style-type: none"> <li>■ RMC 12.2Kbps link</li> </ul>	<ul style="list-style-type: none"> <li>■ RMC 12.2Kbps link</li> </ul>

Note: The maximum power levels are GSM mode for GMSK link, GPRS multi-slot class 12 mode for GMSK link, EGPRS multi-slot class 12 mode for 8PSK link, RMC12.2Kbps mode for WCDMA Band V/II. only these modes were used for all tests.

The conducted burst power tables are as follows:

Conducted Burst Power (dBm)						
Band	GSM850			PCS1900		
Channel	128	190	251	512	661	810
Frequency	824.20	836.60	848.80	1850.20	1880.00	1909.80
GSM (GMSK, 1 TX slot)	32.26	32.29	32.04	28.95	29.44	28.96
GPRS (GMSK, 1 TX slot)	31.19	31.12	31.05	28.33	28.45	28.67
GPRS (GMSK, 2 TX slot)	30.31	30.87	30.77	27.16	27.99	28.08
GPRS (GMSK, 3 TX slot)	29.07	29.87	29.19	26.50	26.55	27.23
GPRS (GMSK, 4 TX slot)	28.34	29.22	28.61	24.62	24.63	24.84
EGPRS (8PSK, 1 TX slot)	26.23	26.39	26.87	26.21	26.89	26.26
EGPRS (8PSK, 2 TX slot)	24.10	24.11	24.28	23.09	23.51	23.99
EGPRS (8PSK, 3 TX slot)	22.30	22.83	22.31	21.35	21.58	22.08
EGPRS (8PSK, 4 TX slot)	20.41	21.25	20.77	20.51	20.57	20.88

Burst Average Power (dBm)									
Band	WCDMA Band II			WCDMA Band IV			WCDMA Band V		
Channel	9262	9400	9538	1313	1413	1512	4132	4183	4233
Frequency	1852.4	1880.0	1907.6	1712.6	1732.6	1752.4	826.4	836.6	846.6
RMC 12.2Kbps	23.89	23.50	24.19	23.08	22.94	22.42	23.08	23.97	23.03
HSDPA Subtest-1	23.13	23.11	23.08	22.57	22.25	22.20	22.08	21.88	21.90
HSDPA Subtest-2	23.07	22.85	22.69	22.15	21.85	21.35	21.75	22.04	22.06
HSDPA Subtest-3	22.98	23.19	22.61	21.86	22.14	21.75	21.65	21.96	22.24
HSDPA Subtest-4	22.97	23.22	23.27	22.45	22.57	22.25	21.75	21.76	21.83
HSUPA Subtest-1	22.76	23.08	23.10	22.15	22.64	21.49	21.45	22.01	22.14
HSUPA Subtest-2	23.52	23.08	23.11	22.37	22.44	22.65	21.88	22.69	21.82
HSUPA Subtest-3	22.60	22.77	22.27	22.29	22.65	21.94	21.88	22.47	22.58
HSUPA Subtest-4	22.71	22.63	22.68	22.54	21.92	21.63	22.49	22.66	21.62
HSUPA Subtest-5	22.61	22.84	23.24	21.66	21.76	22.09	22.57	22.47	22.39
AMR	22.58	23.33	23.46	22.06	22.48	22.14	22.45	22.47	22.60

## 4.2 Configuration of Tested System

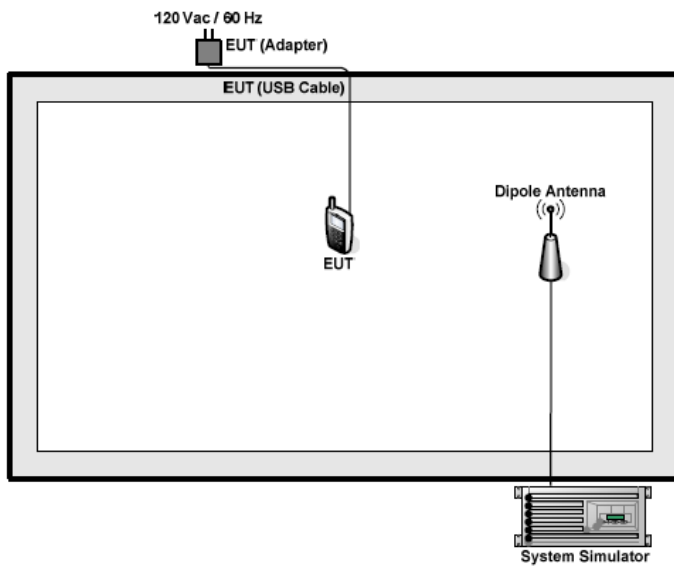

### 4.3 Conducted AV Output Power

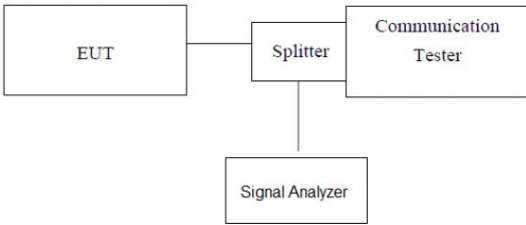
Test Requirement:	FCC part22.913(a), FCC part24.232(b), FCC part27.50(d)(4), RSS-132 (5.4), RSS-133 (4.1), RSS-139(4.1)
Test Method:	FCC part2.1046, TIA/EIA-603-D, ANSI C63.26 clause 5.2.4 FCC KDB971168 D01 v03r01 Section 5.2.
Limit:	GSM850, WCDMA Band V: 7W(ERP) PCS1900, WCDMA Band II: 2W(EIRP) WCDMA Band IV: 1W(EIRP)
Test setup:	 <pre> graph LR     EUT[EUT] --- Splitter[Splitter]     Splitter --- CT[Communication Tester]     Splitter --- SA[Signal Analyzer]   </pre> <p><i>Note: Measurement setup for testing on Antenna connector</i></p>
Test Procedure:	<ol style="list-style-type: none"> <li>1. The transmitter output port was connected to base station.</li> <li>2. The RF output of EUT was connected to the Signal Analyzer by RF cable and attenuator, the path loss was compensated to the results for each measurement.</li> <li>3. Set EUT at maximum power through base station.</li> <li>4. Select lowest, middle, and highest channels for each band and different modulation.</li> <li>5. Measure the maximum frame average power.</li> </ol>
Test Instruments:	Refer to section 3 for details
Test mode:	Refer to section 4.1 for details
Test results:	Pass

## Measurement Data

Frame Average Power (dBm)						
Band	GSM 850			PCS 1900		
Channel	128	190	251	512	661	810
Frequency (MHz)	824.2	836.6	848.8	1850.2	1880.0	1909.8
GSM (GMSK, 1 TX slot)	22.83	23.21	23.45	19.95	20.81	20.18
GPRS (GMSK, 1-Slot)	22.61	22.75	23.36	19.75	20.20	20.20
GPRS (GMSK, 2-Slot)	24.40	24.95	24.66	21.13	21.98	21.45
GPRS (GMSK, 3-Slot)	25.04	25.44	25.77	22.31	22.85	22.82
GPRS (GMSK, 4-Slot)	24.81	25.64	25.28	22.10	22.37	22.17
EGPRS (8PSK, 1-Slot)	16.98	17.08	17.52	16.44	17.23	17.29
EGPRS (8PSK, 2-Slot)	17.63	18.01	17.70	17.14	17.32	17.68
EGPRS (8PSK, 3-Slot)	17.51	17.94	18.44	17.64	17.65	18.43
EGPRS (8PSK, 4-Slot)	17.39	17.73	17.57	17.40	17.69	17.57

#### 4.4 Peak-to-Average Ratio

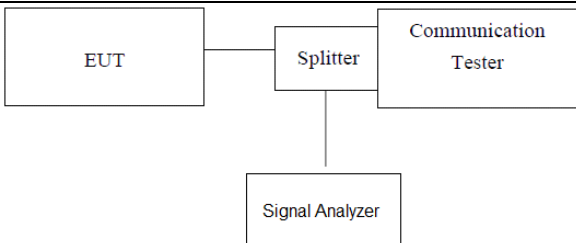
Test Requirement:	Part 22.913(d), FCC part24.232(d), FCC part27.50(d)(5), RSS-132 (5.4), RSS-133 (6.4), RSS-139(6.5)
Test Method:	FCC part2.1046, ANSI/TIA-603-D, ANSI C63.26 Clause 5.2.3.4 FCC KDB971168 D01 v03r01 Section 5.7
Limit:	13db
Test setup:	 <pre> graph LR     EUT[EUT] --- Splitter[Splitter]     Splitter --- CT[Communication Tester]     Splitter --- SA[Signal Analyzer]   </pre> <p><i>Note: Measurement setup for testing on Antenna connector</i></p>
Test Procedure:	<ol style="list-style-type: none"> <li>1. The transmitter output port was connected to base station.</li> <li>2. The RF output of EUT was connected to the Signal Analyzer by RF cable and attenuator, the path loss was compensated to the results for each measurement.</li> <li>3. Set EUT at maximum power through base station.</li> <li>4. Select lowest, middle, and highest channels for each band and different modulation.</li> <li>5. Measure the maximum burst average power.</li> <li>6. Record the maximum peak-to-average ratio value.</li> </ol>
Test Instruments:	Refer to section 3 for details
Test mode:	Refer to section 4.1 for details
Test results:	Pass

Measurement data

Test mode	Peak to Average Ratio (dB)			Limit (dB)	Result
	Low Ch.	Middle Ch.	High Ch.		
GSM/TM1/GSM850(GPRS)	8.85	8.95	9.70	13	PASS
GSM/TM1/GSM1900(GPRS)	8.86	9.17	8.86	13	PASS

GPRS 850  
Low Ch

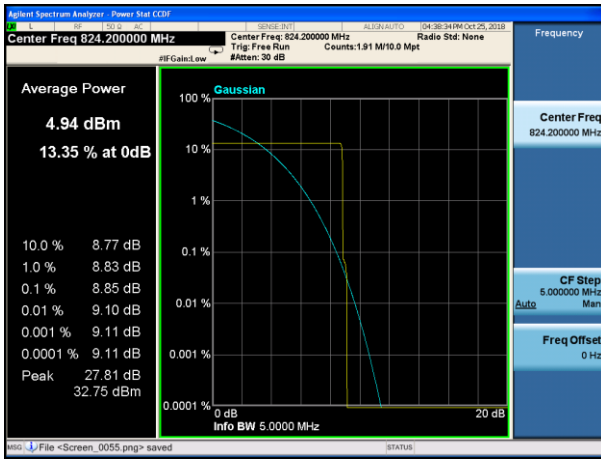

Middle Ch

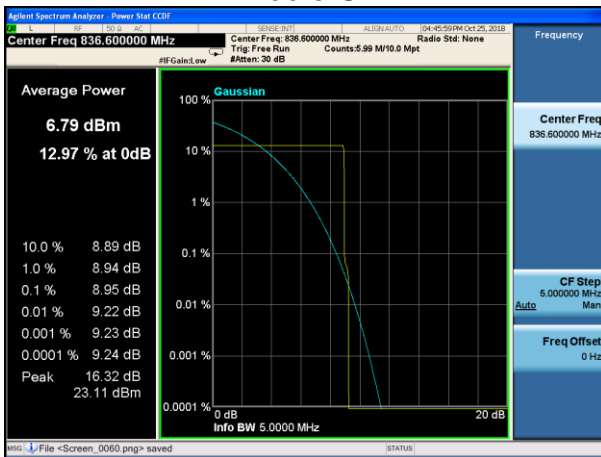

High Ch

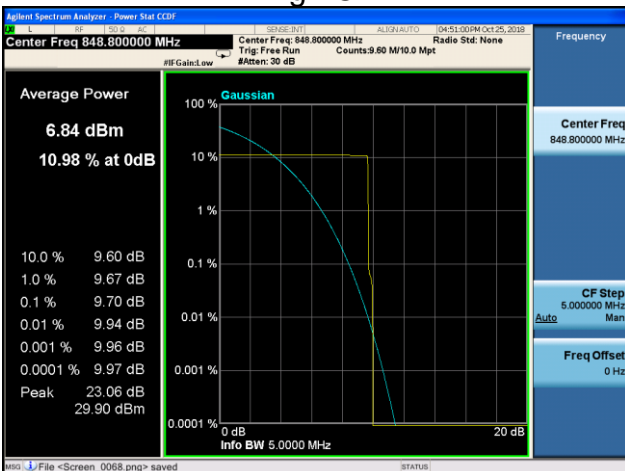

GPRS 1900  
Low Ch

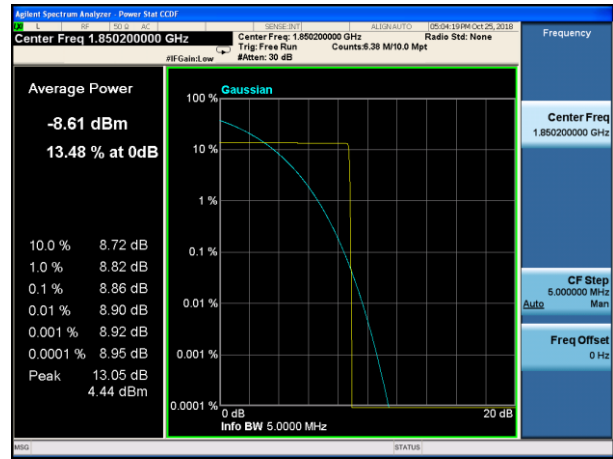

Middle Ch

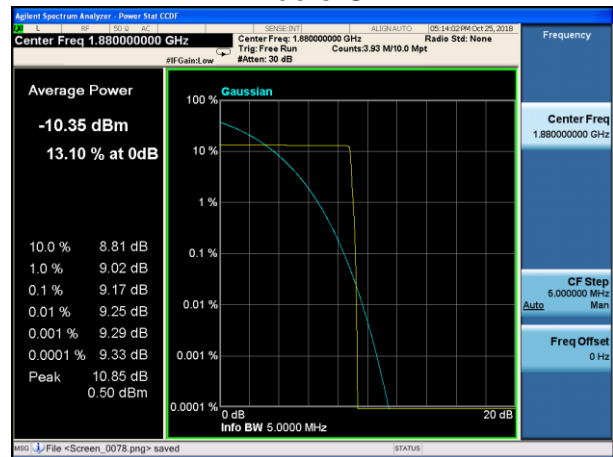

High Ch





Test mode	Peak to Average Ratio (dB)			Limit (dB)	Result
	Low Ch.	Middle Ch.	High Ch.		
GSM/TM1/GSM850(EGPRS)	8.85	8.95	9.42	13	PASS
GSM/TM1/GSM1900(EGPRS)	9.43	9.03	9.02	13	PASS

EGPRS 850  
Low Ch

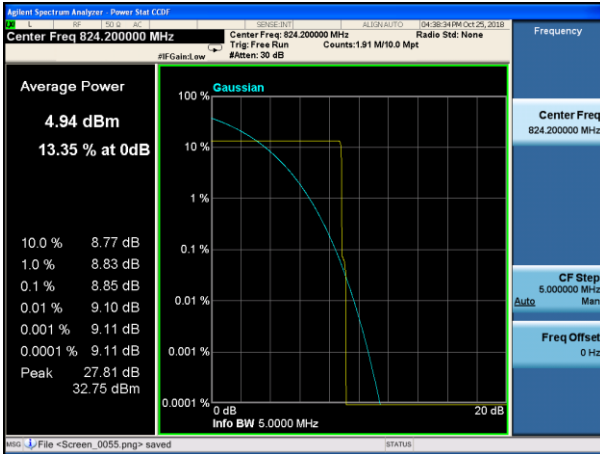

EGPRS 1900  
Low Ch

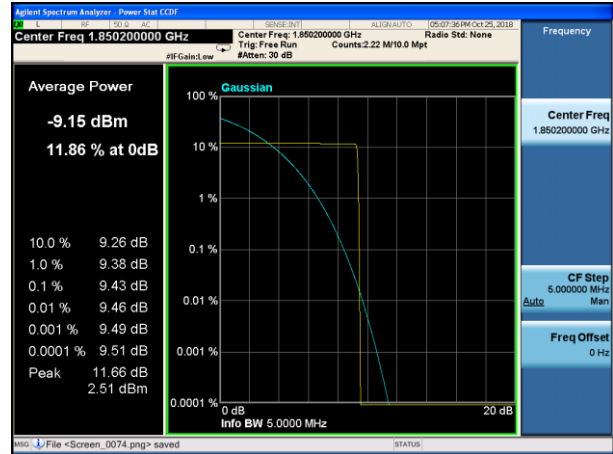

Middle Ch

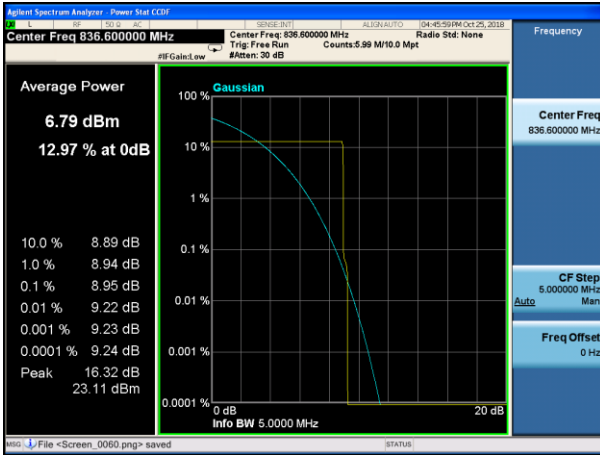

Middle Ch

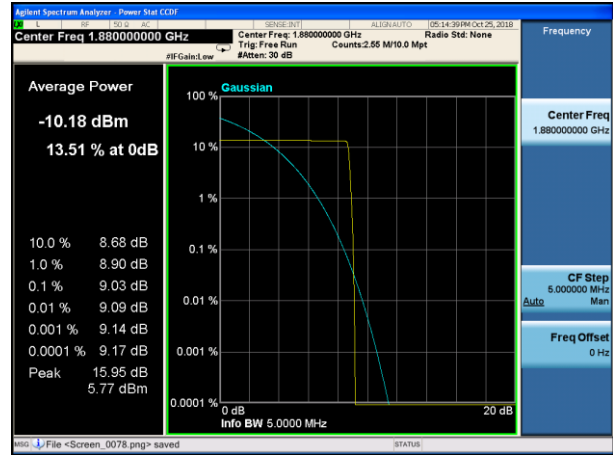

High Ch

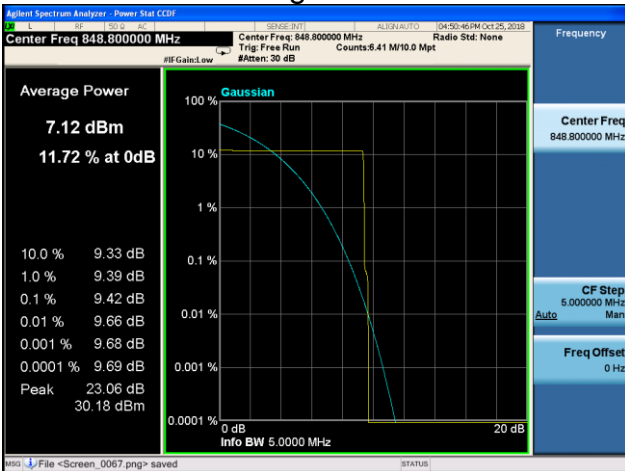

High Ch

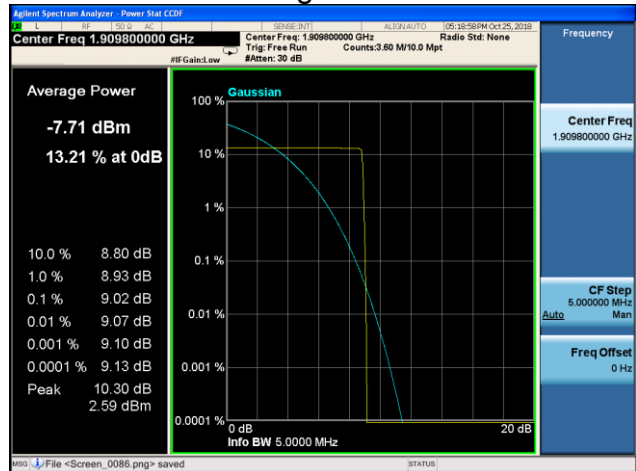

Test mode	Peak to Average Ratio ( dB )			Limit ( dB )	Result
	Low Ch.	Middle Ch.	High Ch.		
WCDMA Band II	3.07	2.99	3.01	13	PASS
WCDMA Band IV	3.34	2.98	3.01		
WCDMA Band V	3.34	2.91	3.33		

WCDMA Band II  
Low Ch

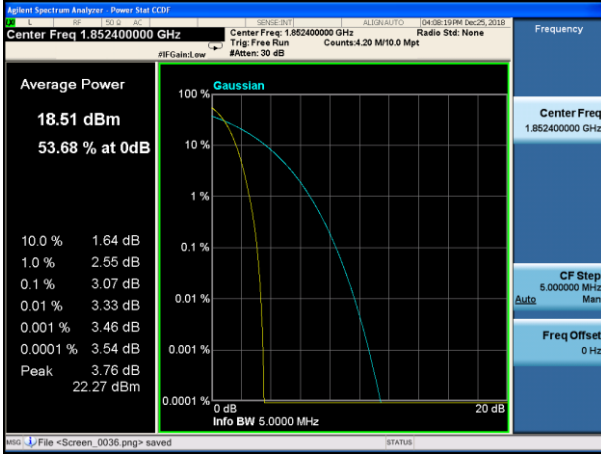

Middle Ch

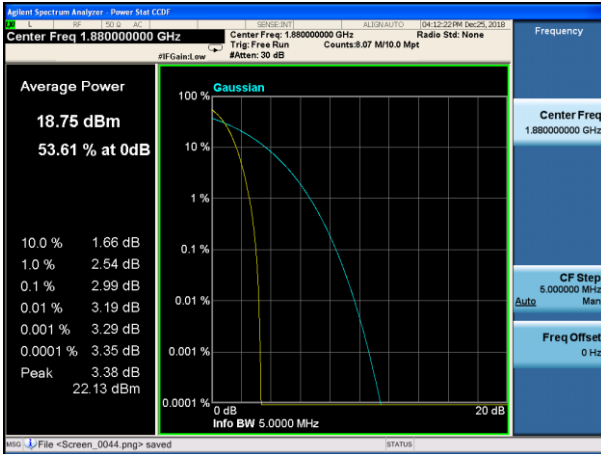

High Ch



WCDMA Band IV  
Low Ch

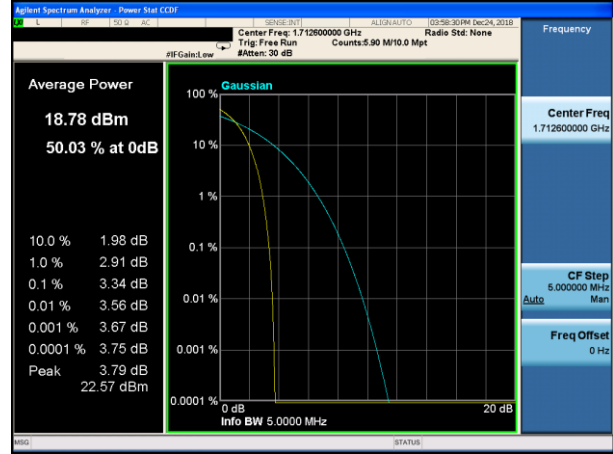

Middle Ch

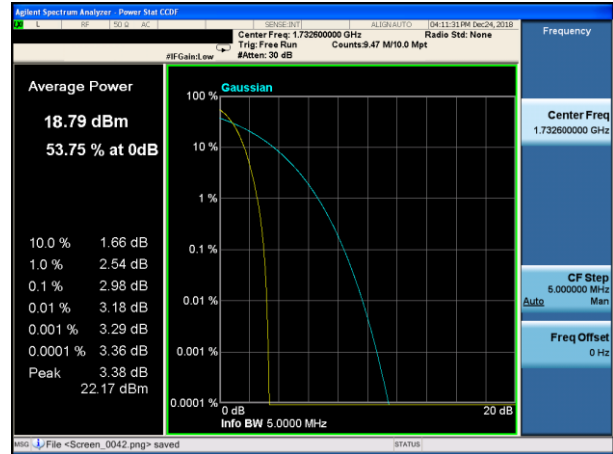

High Ch

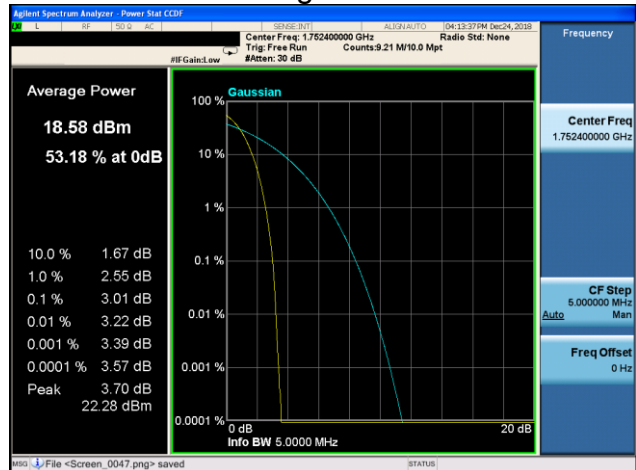

### WCDMA Band V Low Ch

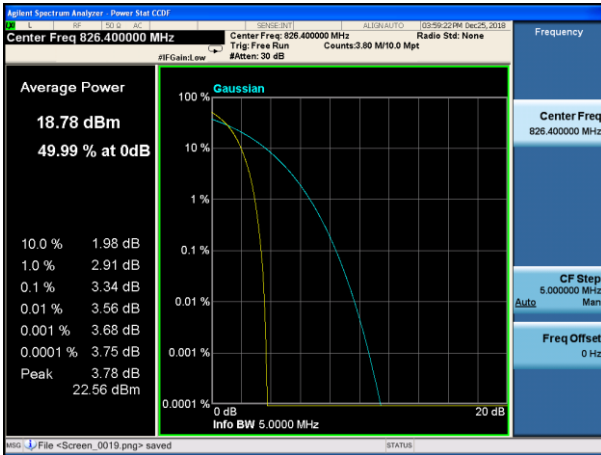

### Middle Ch

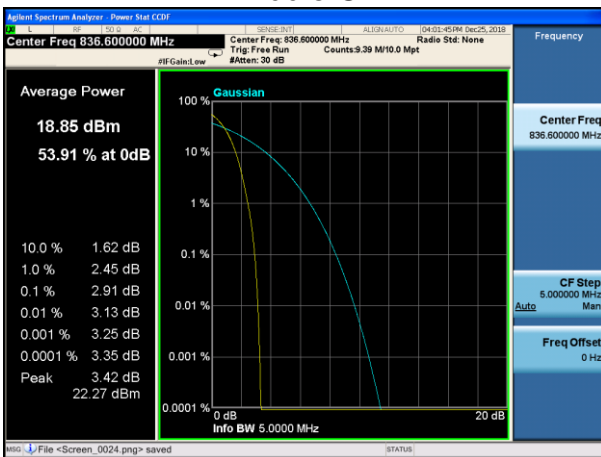

### High Ch

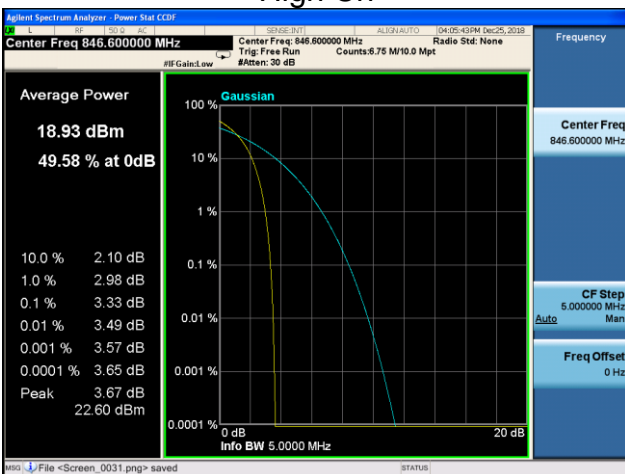

#### 4.5 Occupy Bandwidth

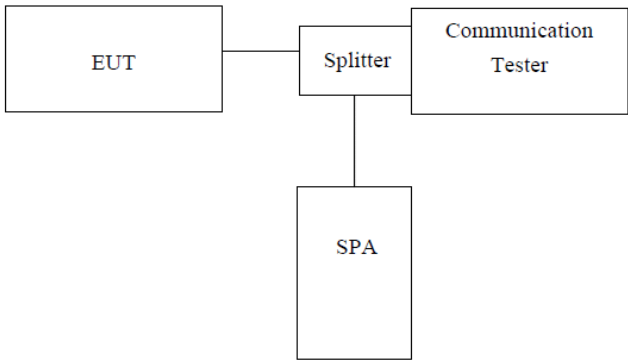
Test Requirement:	FCC part22.913(a), FCC part24.232(b), FCC part27.53(h), RSS-132(3.1), RSS-133(2.3), RSS-139(2.3)
Test Method:	KDB 971168 D01 v03r1 clause 4, FCC part2.1049, ANSI/TIA-603-D, ANSI C63.26 clause 5.4, RSS-Gen Section 6.7.
Test setup:	 <pre> graph LR     EUT[EUT] --- Splitter[Splitter]     Splitter --- CT[Communication Tester]     Splitter --- SPA[SPA]   </pre> <p><i>Note: Measurement setup for testing on Antenna connector</i></p>
Test Procedure:	<ol style="list-style-type: none"> <li>1. The EUT's output RF connector was connected with a short cable to the spectrum analyzer</li> <li>2. RBW was set to about 1% of emission BW, VBW= 3 times RBW.</li> <li>3. -26dBc display line was placed on the screen (or 99% bandwidth), the occupied bandwidth is the delta frequency between the two points where the display line intersects the signal trace.</li> </ol>
Test Instruments:	Refer to section 3 for details
Test mode:	Refer to section 4.1 for details
Test results:	Pass

## Measurement Data

EUT Mode	Channel	Frequency (MHz)	99% Occupy bandwidth (KHz)	-26dB bandwidth (KHz)
GSM 850 (GSM link)	128	824.20	244.26	317.0
	190	836.60	246.48	318.3
	251	848.80	242.50	315.6
GSM 850 (GPRS 1 link)	128	824.20	243.06	316.3
	190	836.60	241.49	315.7
	251	848.80	244.52	322.9
GSM 850 (EGPRS 1 link)	128	824.20	247.25	314.0
	190	836.60	240.99	319.2
	251	848.80	248.18	318.1
PCS 1900 (GSM link)	512	1850.20	249.33	315.5
	661	1880.00	243.26	315.6
	810	1909.80	243.51	316.1
PCS 1900 (GPRS 1 link)	512	1850.20	243.81	322.7
	661	1880.00	247.53	312.3
	810	1909.80	241.20	310.1
PCS 1900 (EGPRS 1 link)	512	1850.20	241.67	314.5
	661	1880.00	247.48	316.6
	810	1909.80	245.69	312.4
WCDMA Band V (RMC 12.2Kbps link)	4132	826.40	4241.5	4920
	4183	836.60	4278.3	4911
	4233	846.60	4448.4	4948
WCDMA Band II (RMC 12.2Kbps link)	9262	1852.4	4268.2	4900
	9400	1880.0	4251.3	4838
	9538	1907.6	4223.6	4872
WCDMA Band IV (RMC 12.2Kbps link)	1313	1712.6	4271.9	4754
	1413	1732.6	4289.1	4918
	1512	1752.4	4288.3	4944

Test plot as follows:

GSM 850 (GSM link)	GSM 850 (GPRS 1 link)
--------------------	-----------------------



Lowest channel

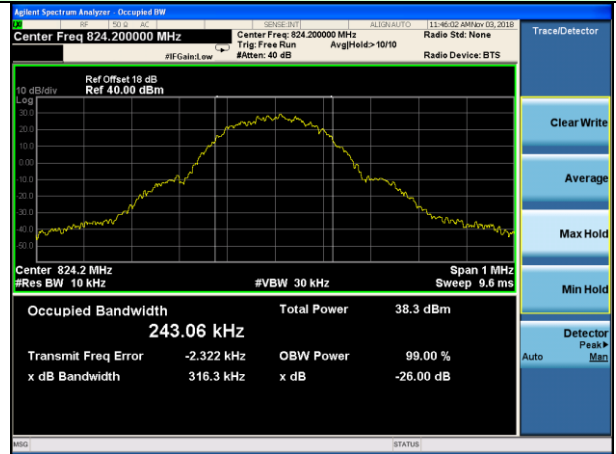

Lowest channel

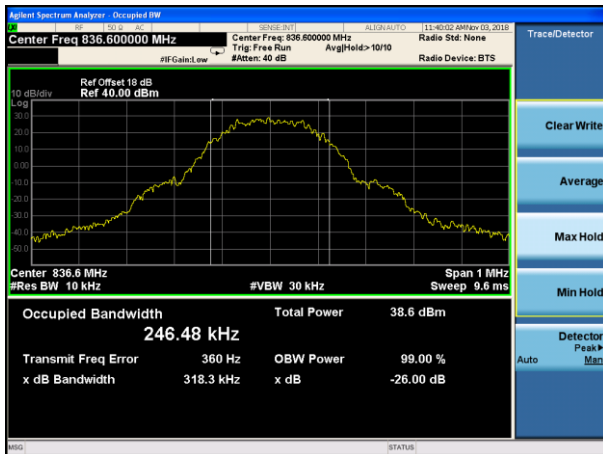

Middle channel

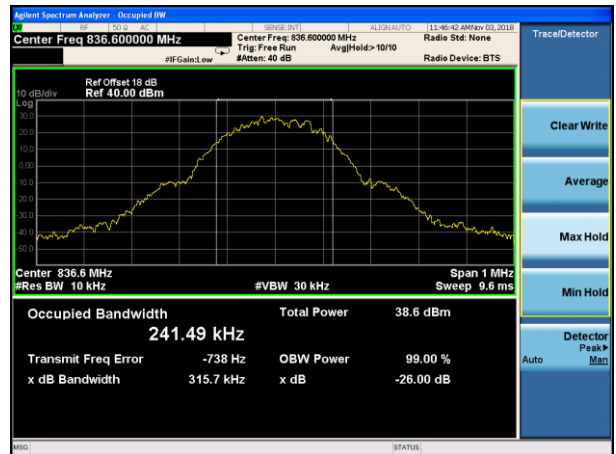

Middle channel

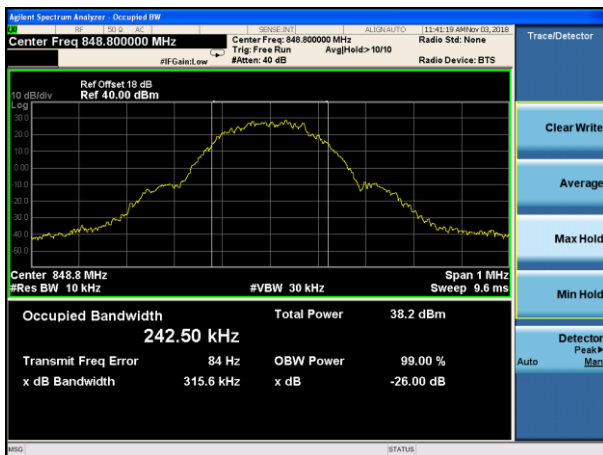

Highest channel

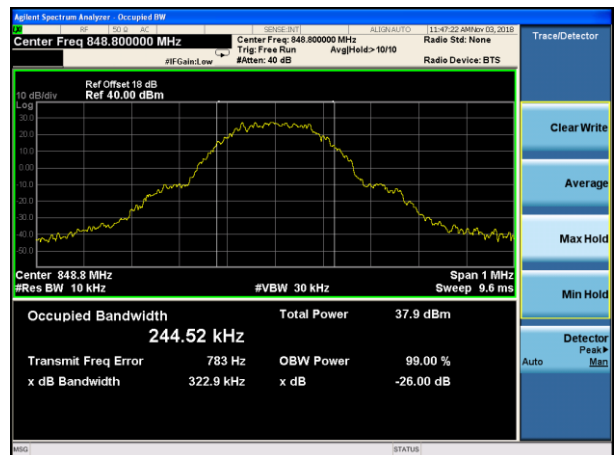

Highest channel

GSM 850 (EGPRS 1 link)

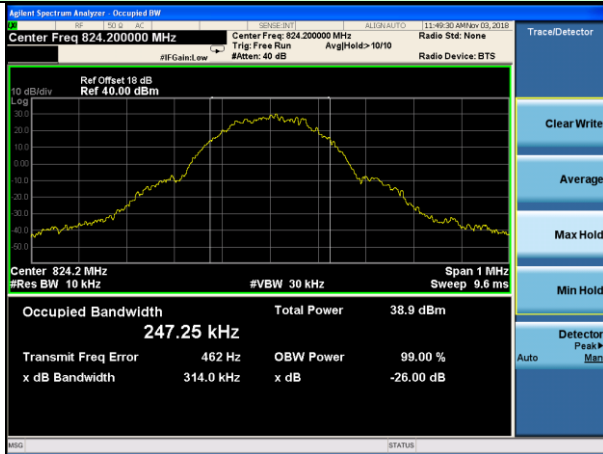

Lowest channel

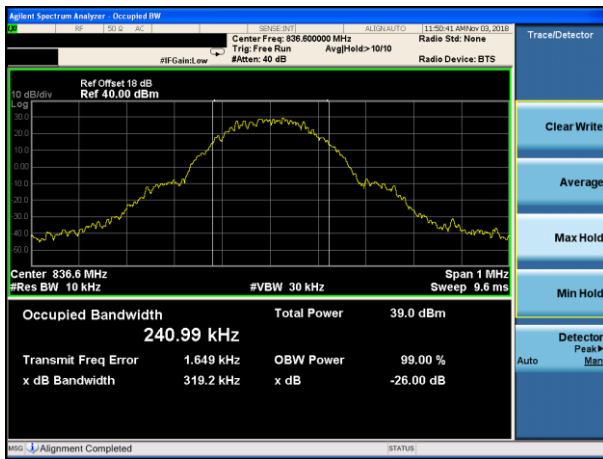

Middle channel

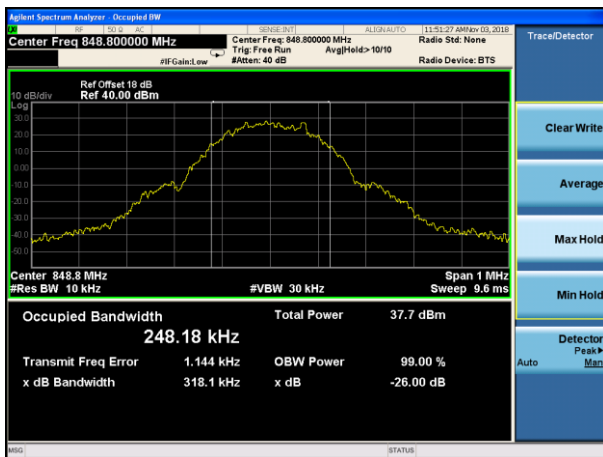

Highest channel

PCS 1900 (GSM link)

PCS 1900 (GPRS 1 link)

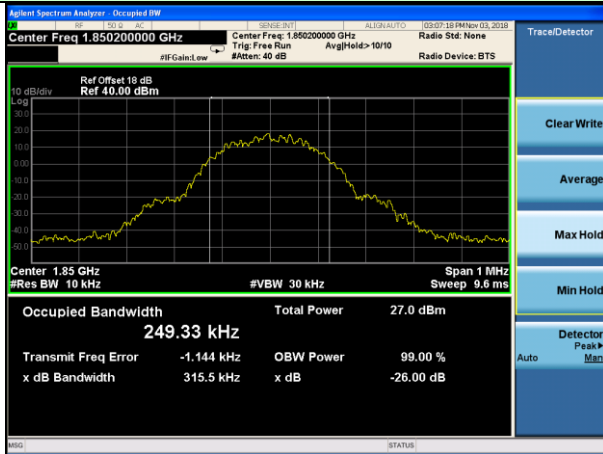

Lowest channel

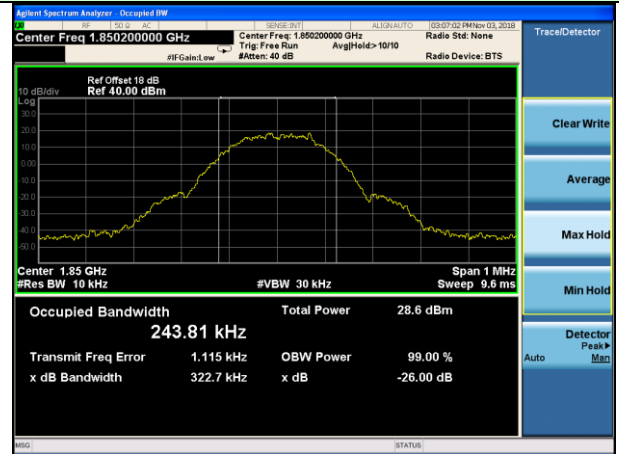

Lowest channel

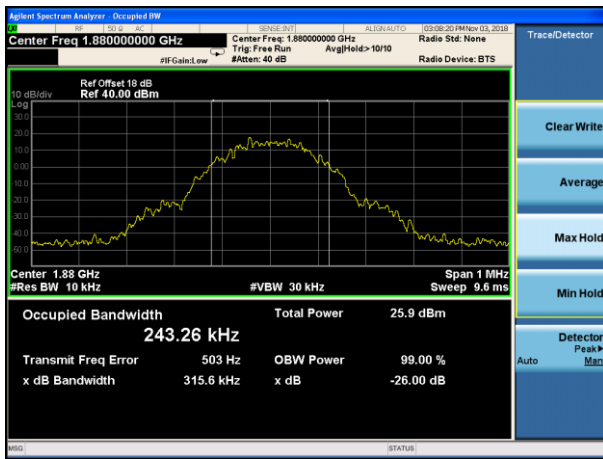

Middle channel

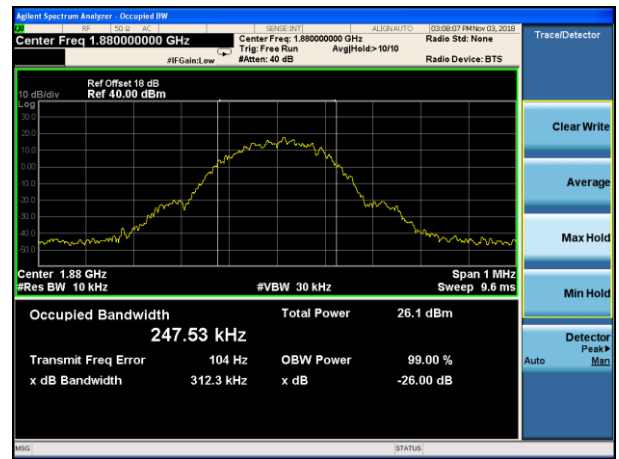

Middle channel

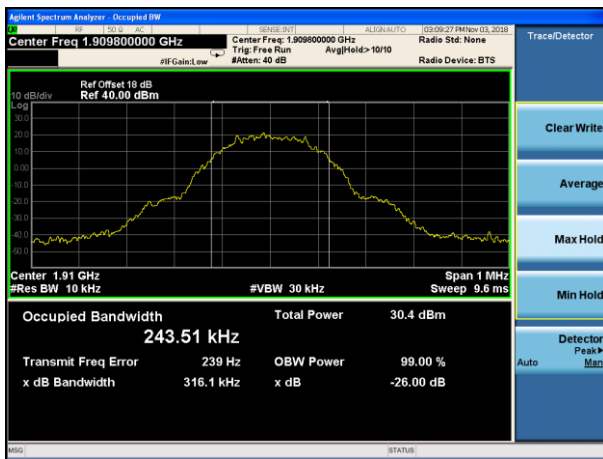

Highest channel

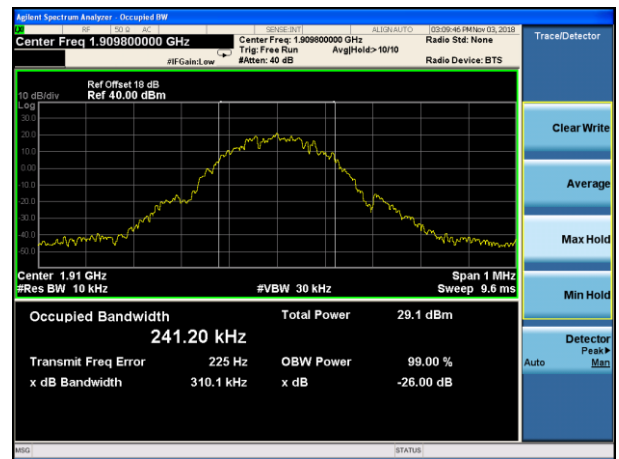

Highest channel



PCS 1900 (EGPRS 1 link)

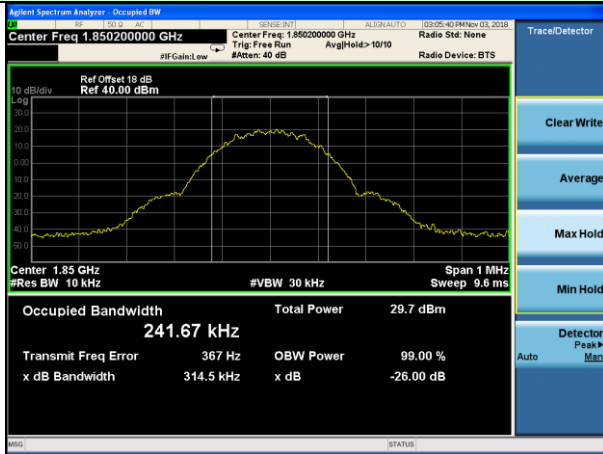

Lowest channel

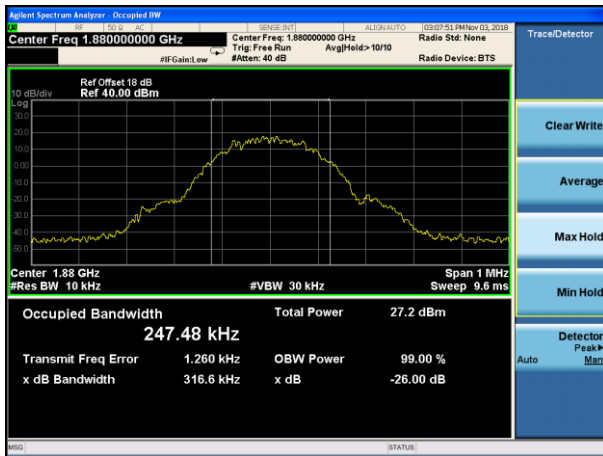

Middle channel

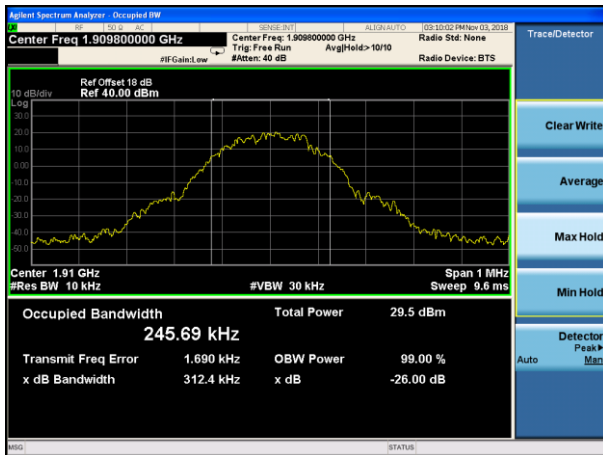

Highest channel

WCDMA Band V (RMC 12.2Kbps link)      WCDMA Band II (RMC 12.2Kbps link)

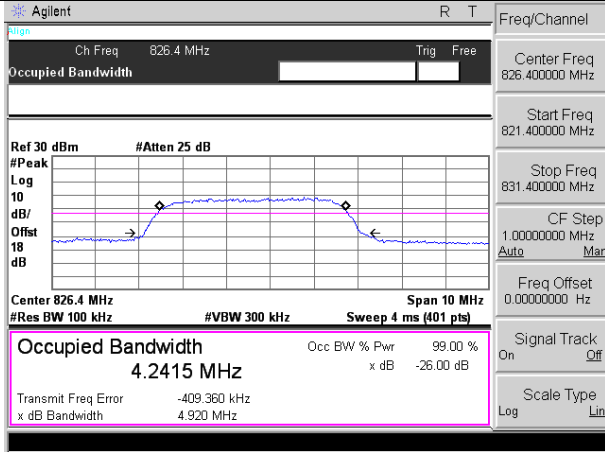

Lowest channel

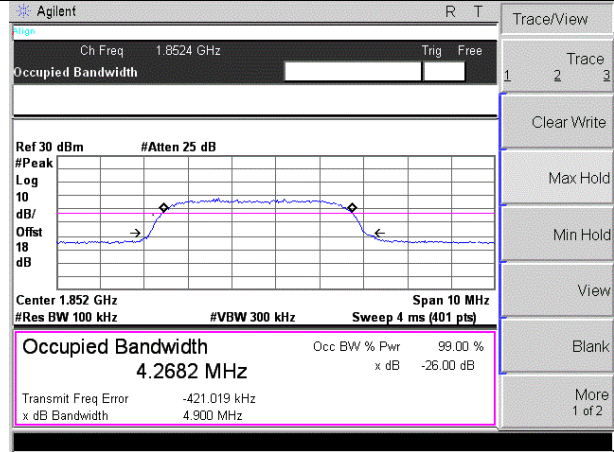

Lowest channel

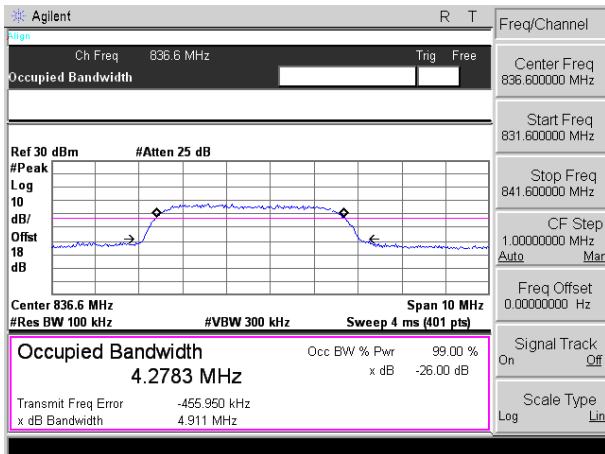

Middle channel

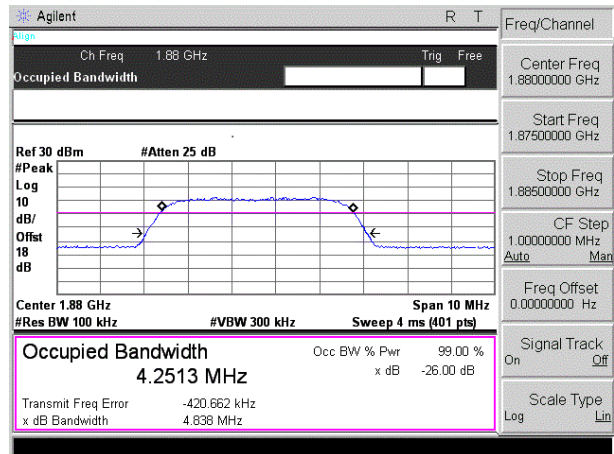

Middle channel

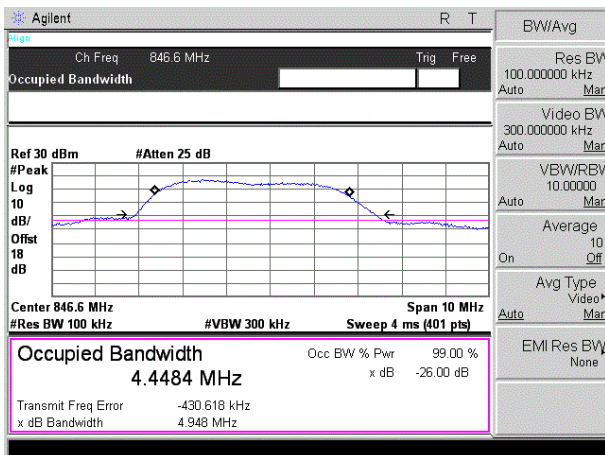

Highest channel

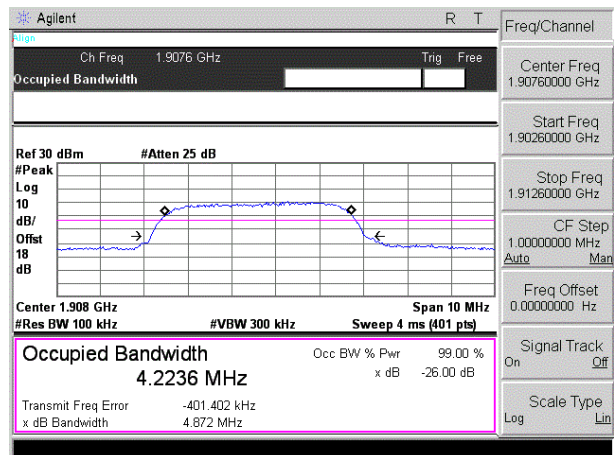

Highest channel

WCDMA Band IV (RMC 12.2Kbps link)

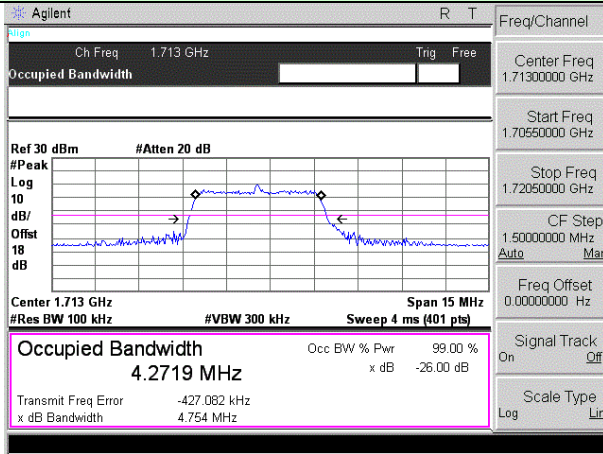

Lowest channel

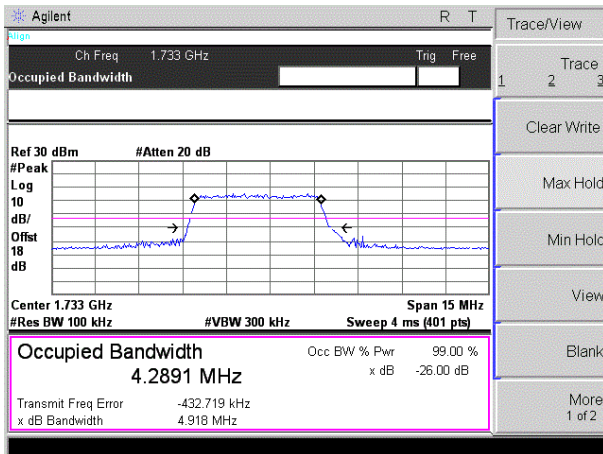

Middle channel

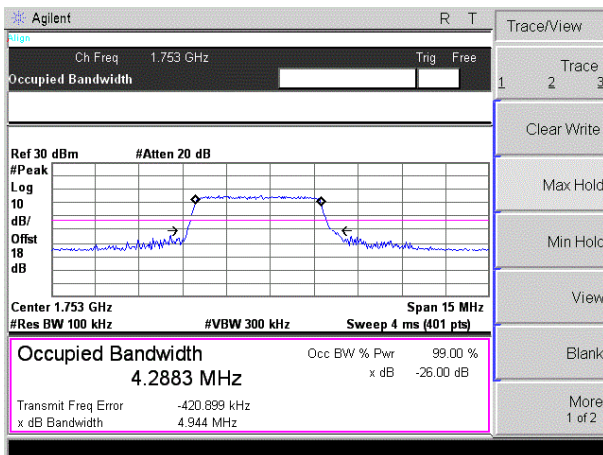

Highest channel

#### 4.6 MODULATION CHARACTERISTIC

According to FCC § 2.1047(d), Part 22H, 24E & 27C, there is no specific requirement for digital modulation, therefore modulation characteristic is not presented.

According to RSS-132, RSS-133, RSS-199, the equipment certified under these standards shall employ digital modulation, but there is no specific requirement for digital modulation, therefore modulation characteristic is not presented.

#### 4.7 Out of band emission at antenna terminals

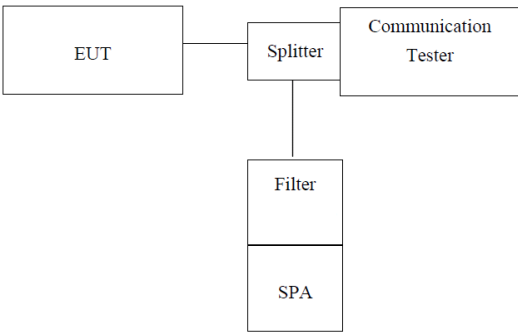
Test Requirement:	FCC part22.917(a), FCC part24.238(a), FCC part27.53(h) RSS-132(5.5), RSS-133(6.5), RSS-139(6.5)
Test Method:	KDB 971168 D01 v03r1 clause 6, FCC part2.1051, ANSI/TIA-603-D, ANSI C63.26 clause 5.7
Limit:	-13dBm
Test setup:	 <p><i>Note: Measurement setup for testing on Antenna connector</i></p>
Test Procedure:	<ol style="list-style-type: none"> <li>1 The RF output of the transceiver was connected to a spectrum analyzer through appropriate attenuation.</li> <li>2 The resolution bandwidth of the spectrum analyzer was set at 1MHz, sufficient scans were taken to show the out of band Emissions if any up to 10th harmonic.</li> <li>3 For the out of band: Set the RBW= 1MHz, VBW = 3MHz, Start=30MHz, Stop= 10th harmonic.</li> <li>4 Band Edge Requirements: In the 1 MHz bands immediately outside and adjacent to the frequency block, a resolution bandwidth of at least 1 percent of the emission bandwidth of the fundamental emission of the transmitter may be employed to measure the out of band Emissions.</li> </ol>
Test Instruments:	Refer to section 3 for details
Test mode:	Refer to section 4.1 for details
Test results:	Pass

Test plot as follows:

Test Mode: Traffic mode GSM 850 (GSM link)

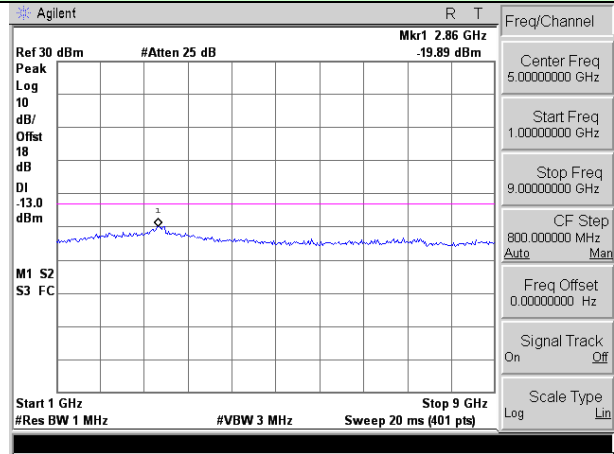
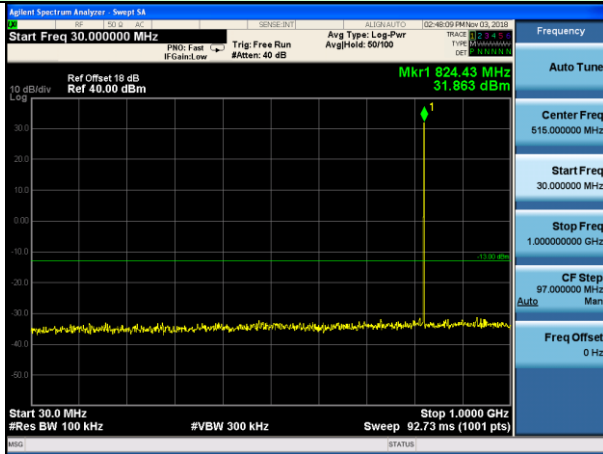

Lowest channel

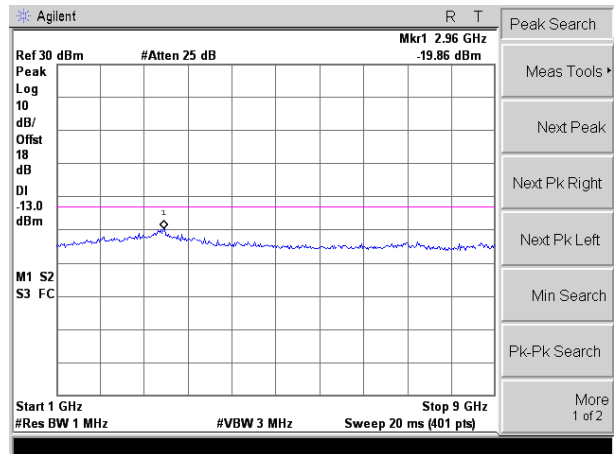
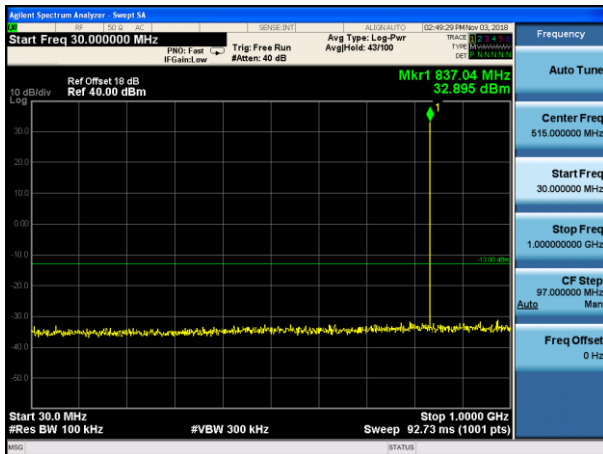

Middle channel

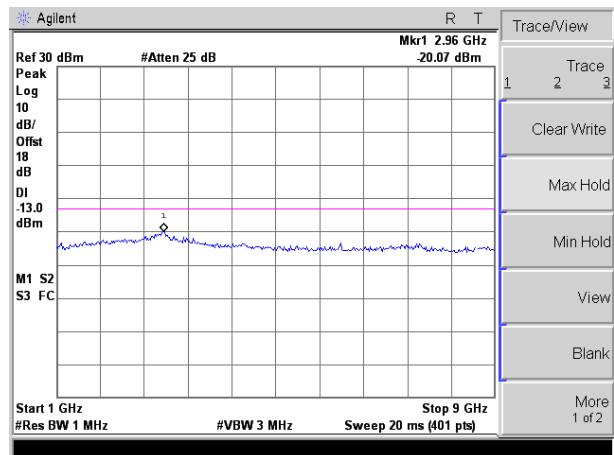
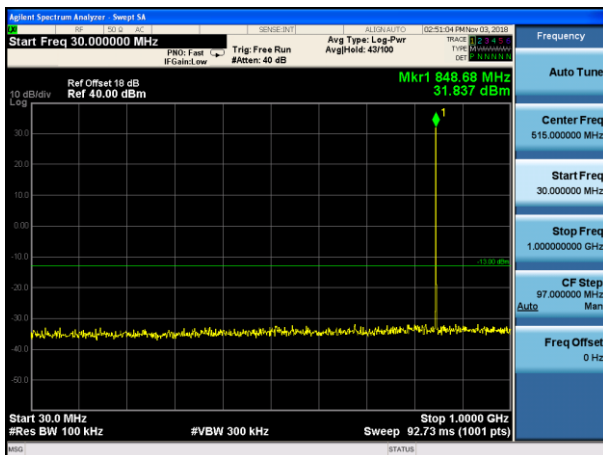

Highest channel

Test Mode: Traffic mode GSM 850 (GPRS 1 link)

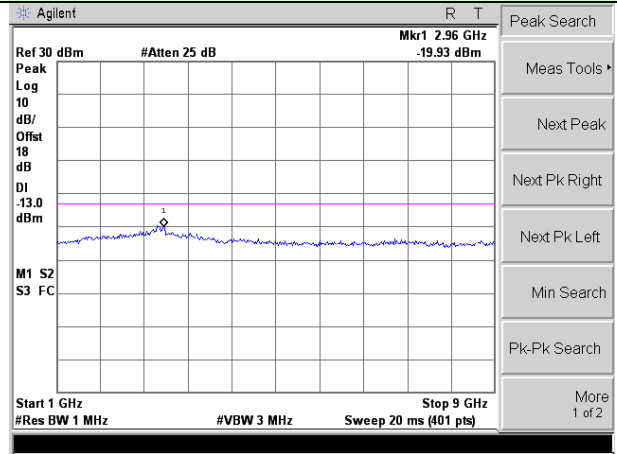
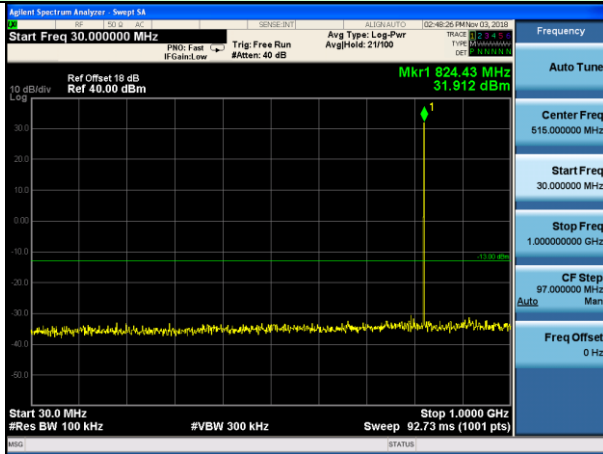

Lowest channel

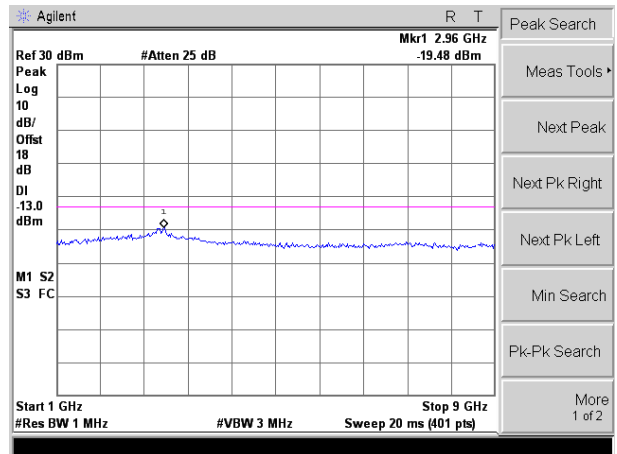
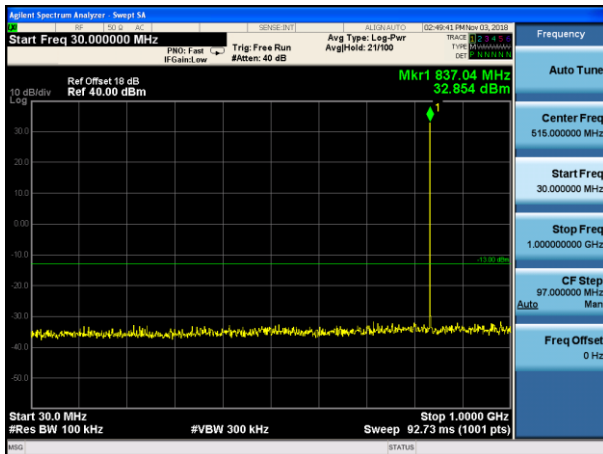

Middle channel

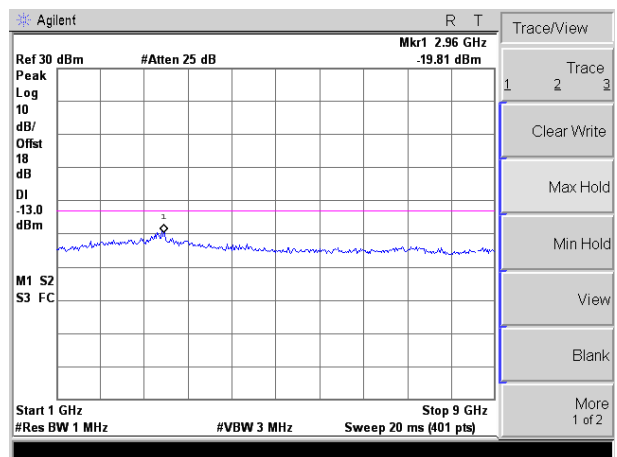
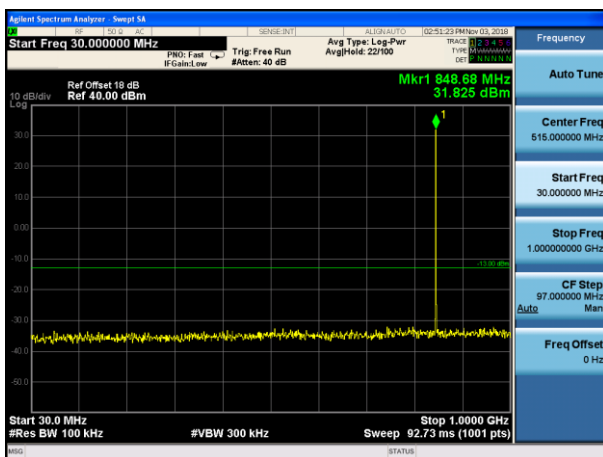

Highest channel

Test Mode: Traffic mode GSM 850 (EGPRS 1 link)

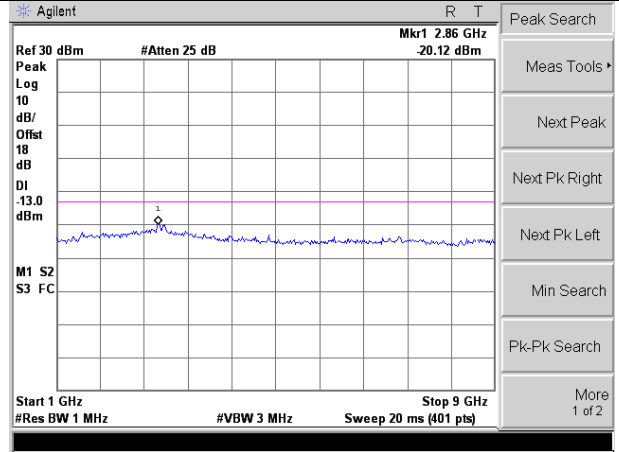
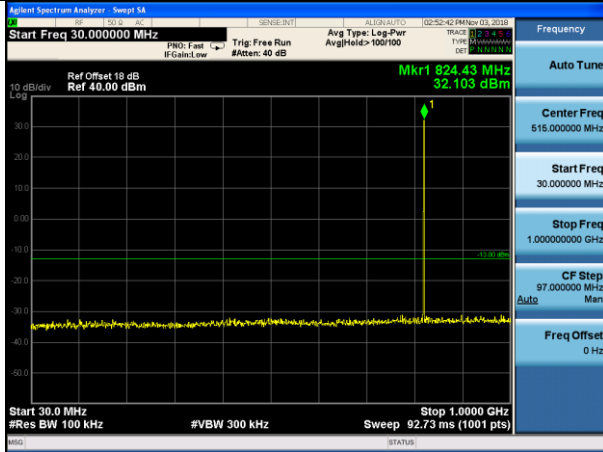

Lowest channel

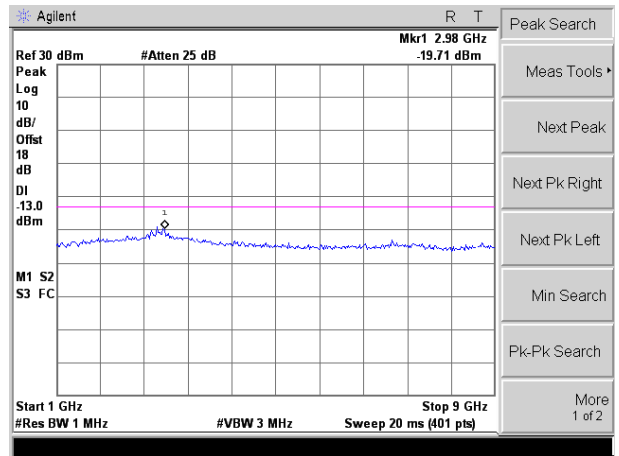
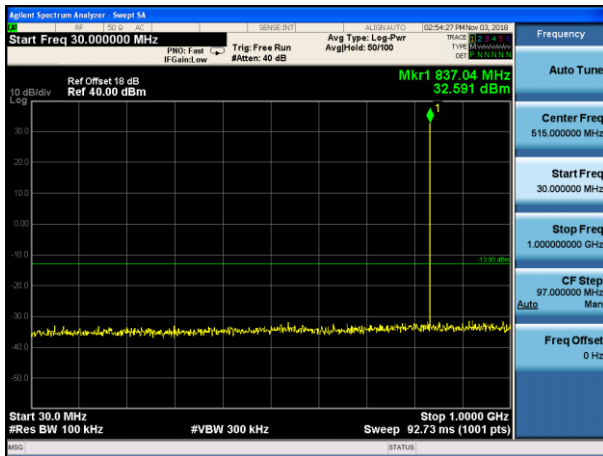

Middle channel

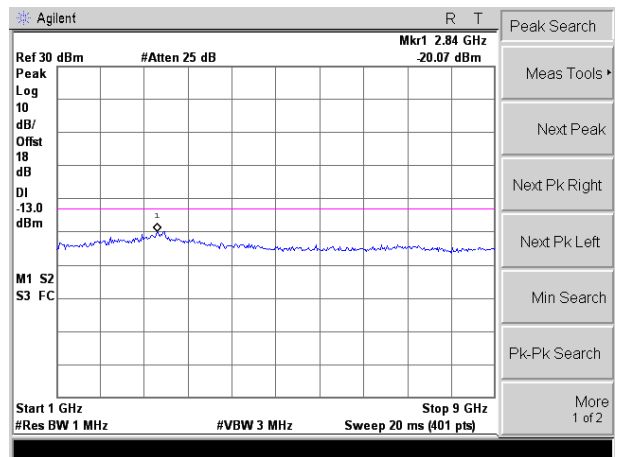
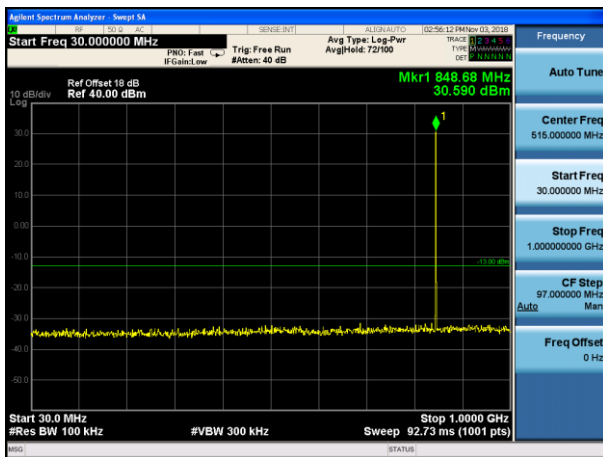

Highest channel



Test Mode: Traffic mode PCS1900 (GSM link)

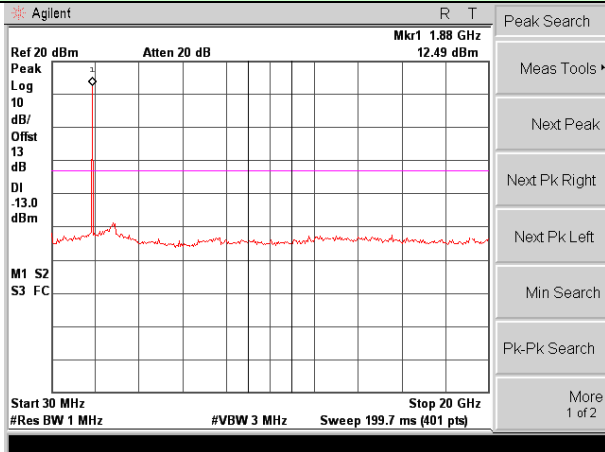

Lowest channel

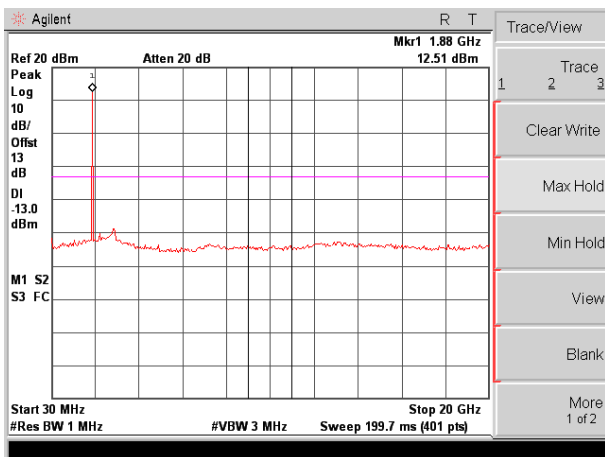

Middle channel

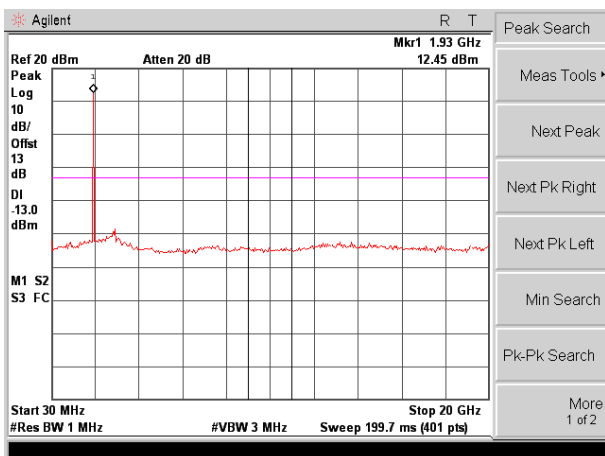

Highest channel



Test Mode: Traffic mode PCS1900 (GPRS 1 link)

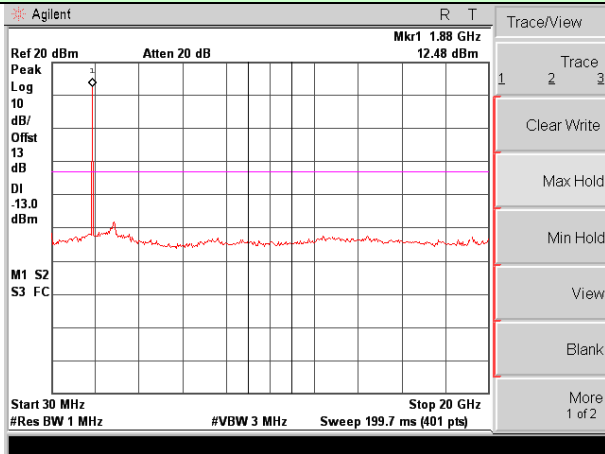

Lowest channel

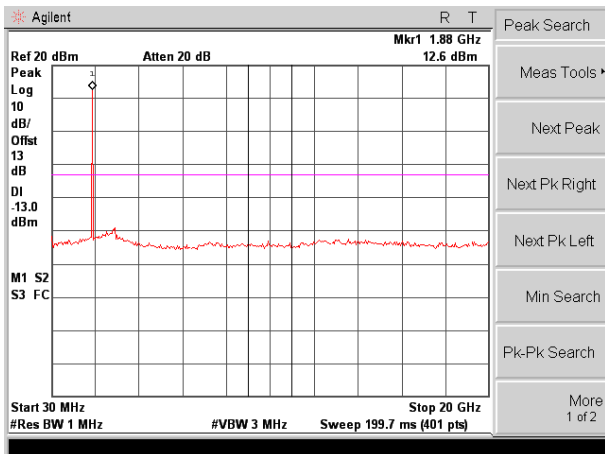

Middle channel

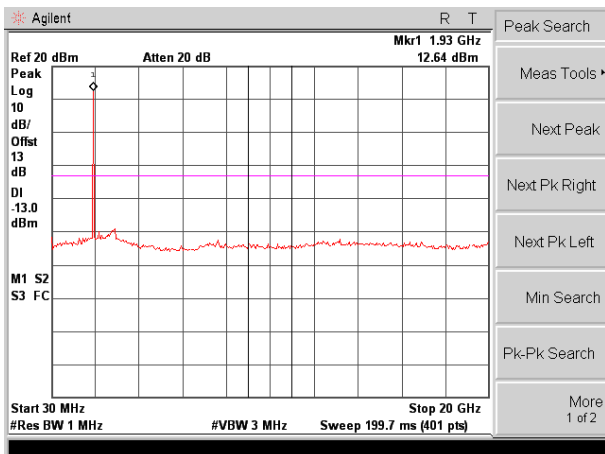

Highest channel

Test Mode: Traffic mode PCS1900 (EGPRS 1 link)

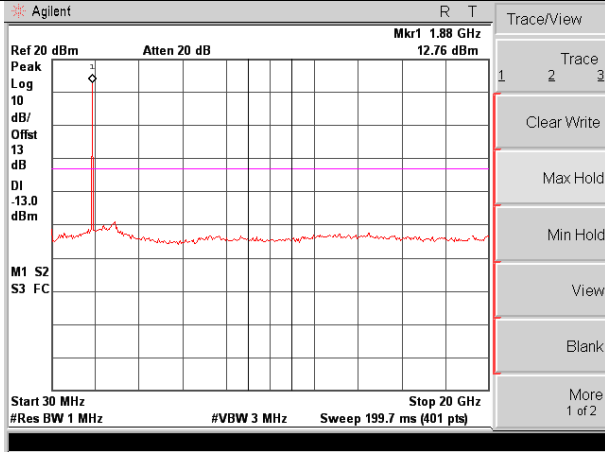

Lowest channel

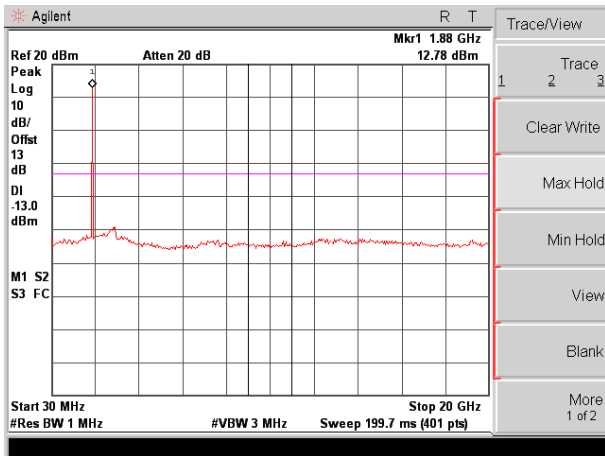

Middle channel

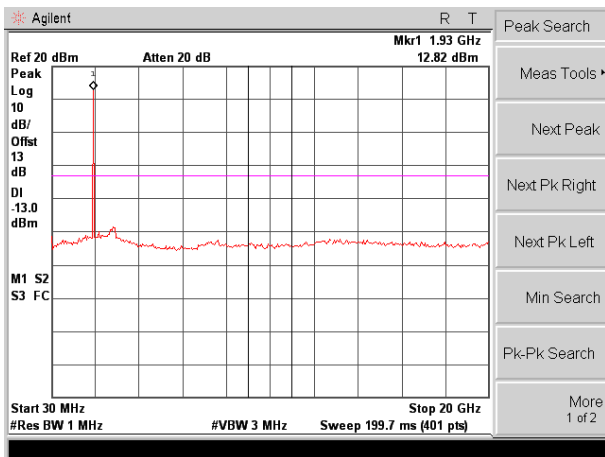

Highest channel

Test Mode: Traffic mode WCDMA Band V (RMC 12.2Kbps link)

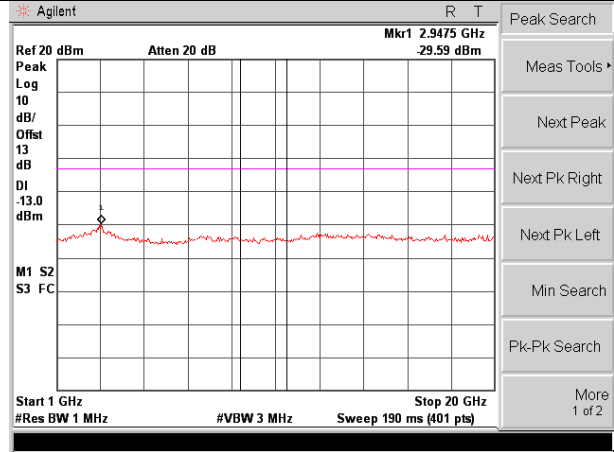
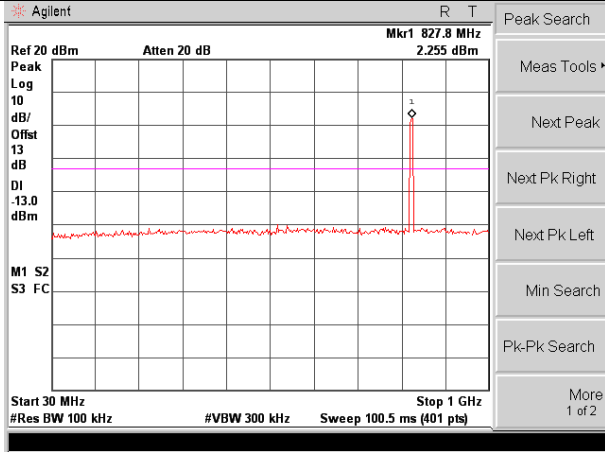

Lowest channel

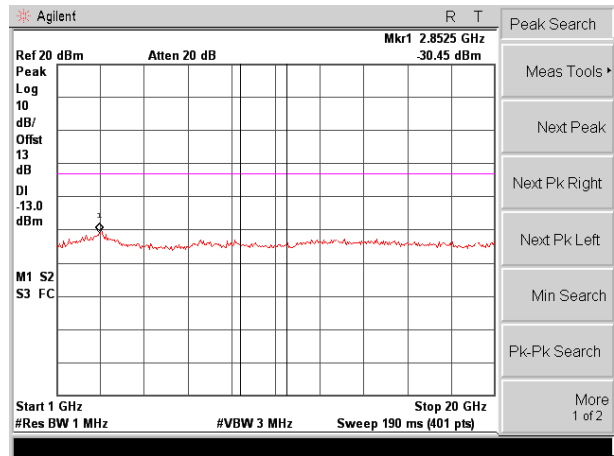
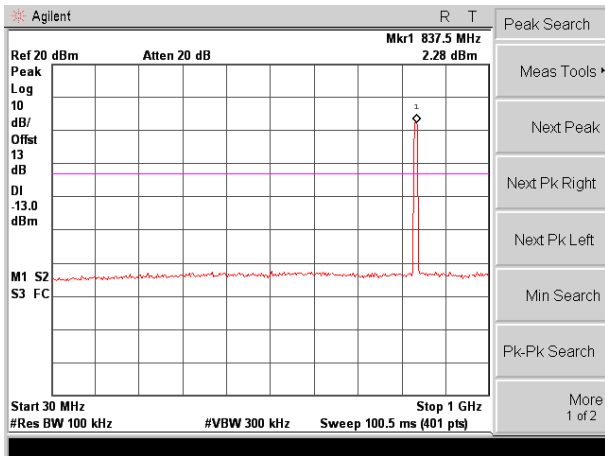

Middle channel

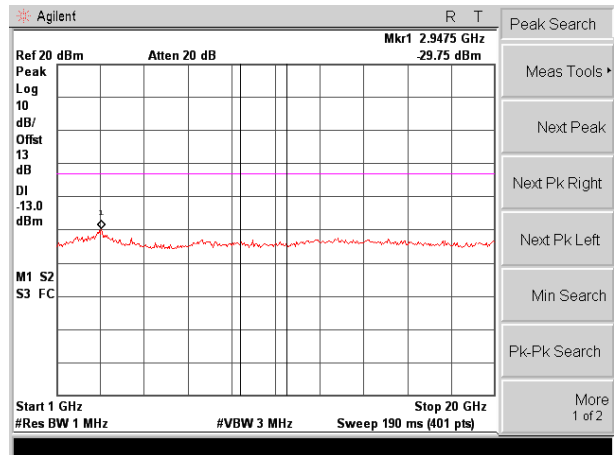
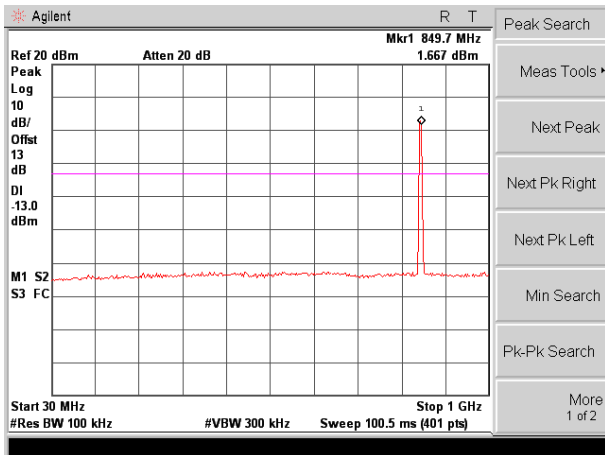

Highest channel

Test Mode: Traffic mode WCDMA Band II (RMC 12.2Kbps link)

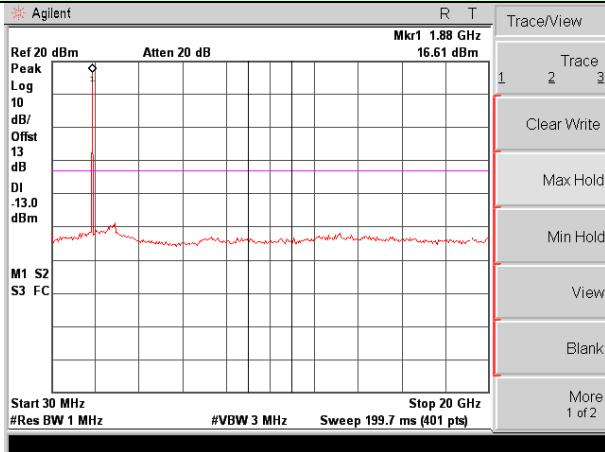

Lowest channel

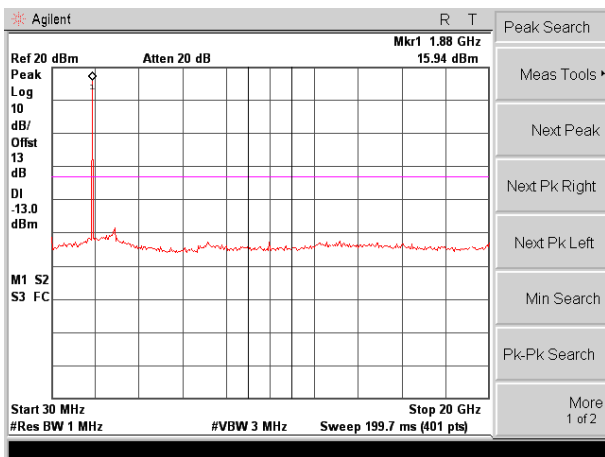

Middle channel

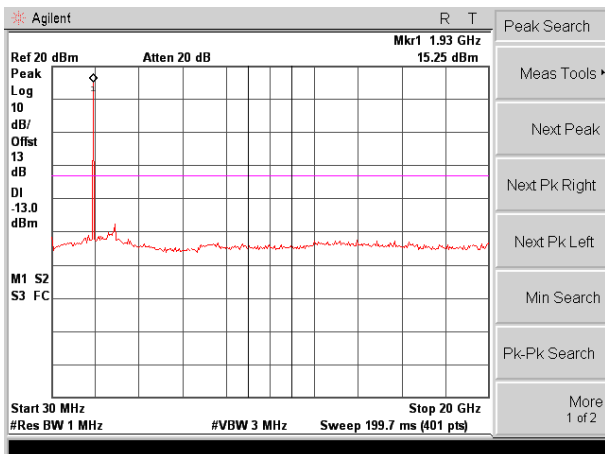

Highest channel

Test Mode: Traffic mode WCDMA Band IV (RMC 12.2Kbps link)

Lowest channel

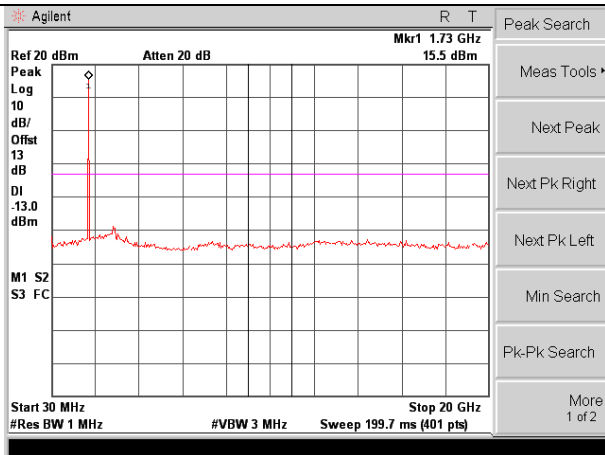

Middle channel

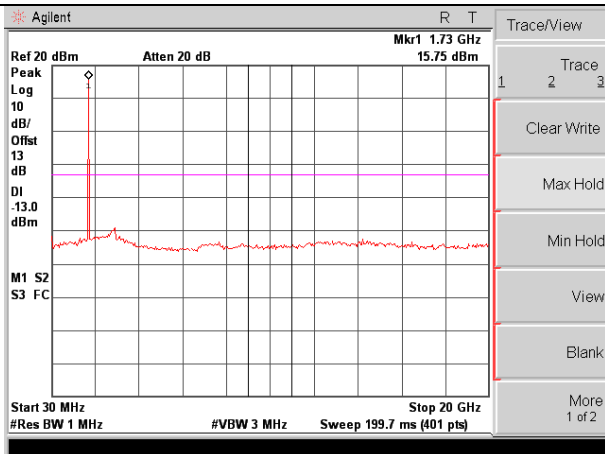

Highest channel

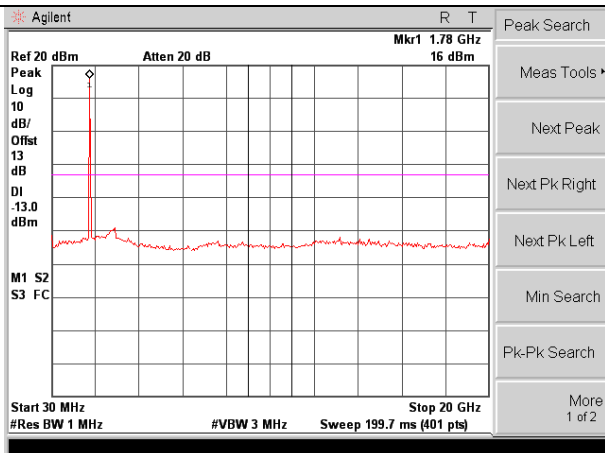

Band Edge:

Test Mode: Traffic mode GSM850 (GSM link)

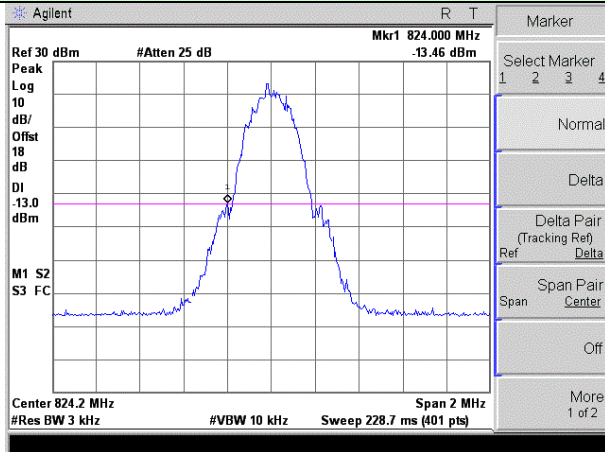

Lowest channel

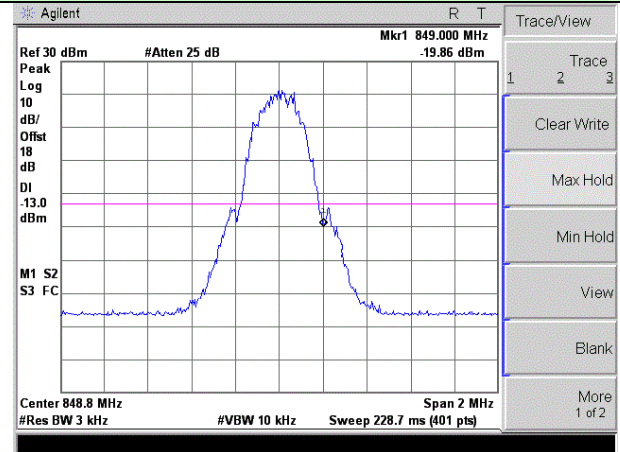

Highest channel

Test Mode: Traffic mode GSM850 (GPRS 1 link)

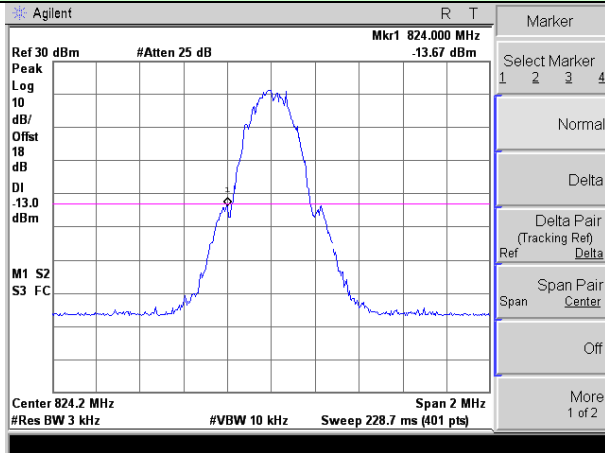

Lowest channel

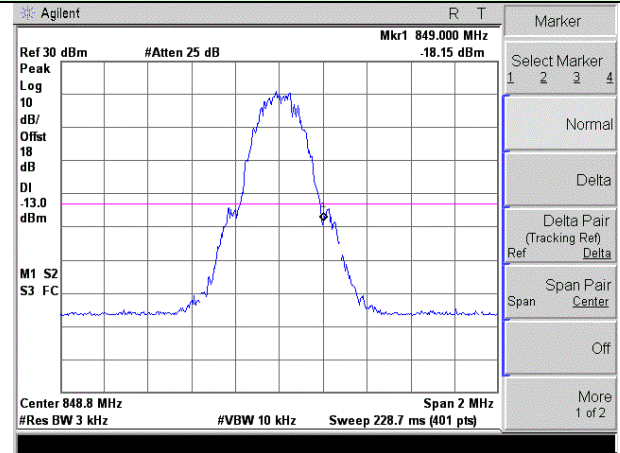

Highest channel

Test Mode: Traffic mode GSM850 (EGPRS 1 link)

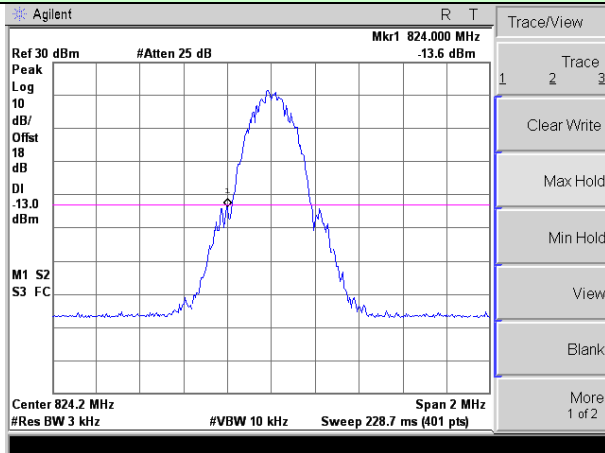

Lowest channel

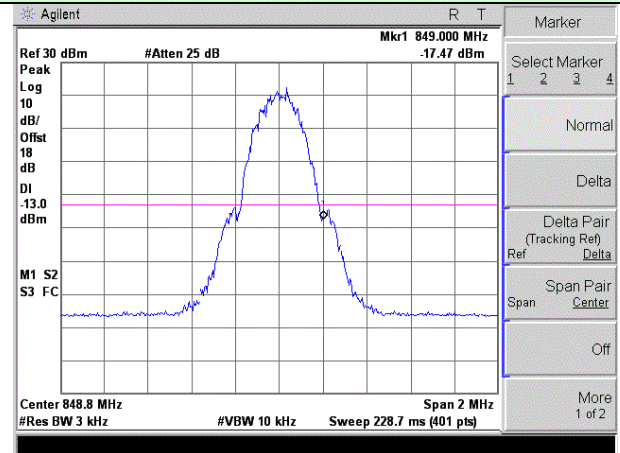

Highest channel

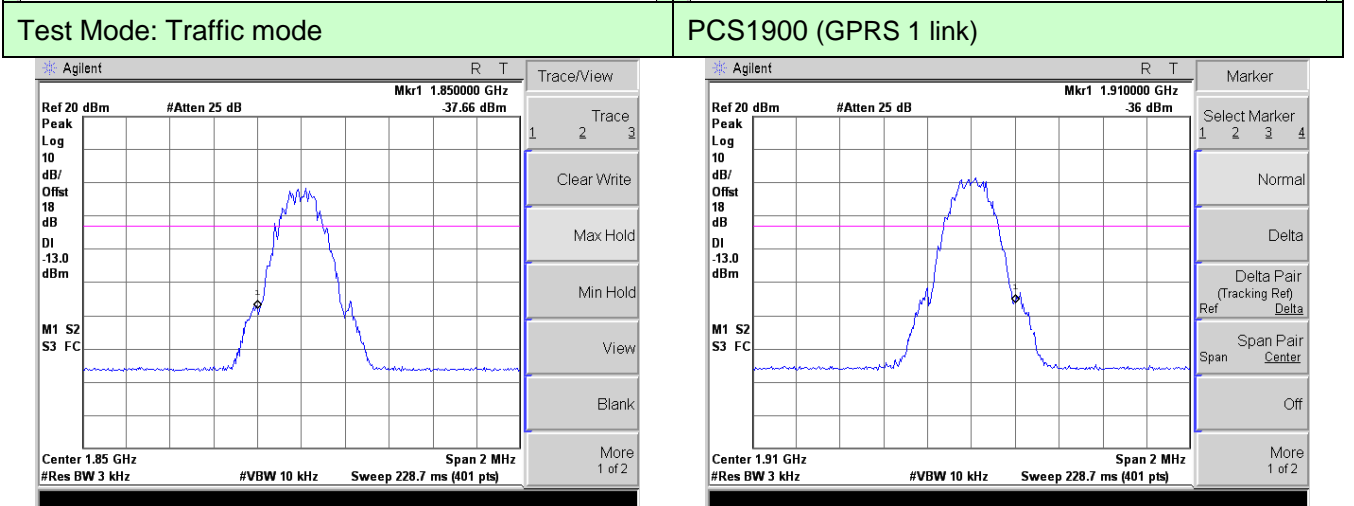
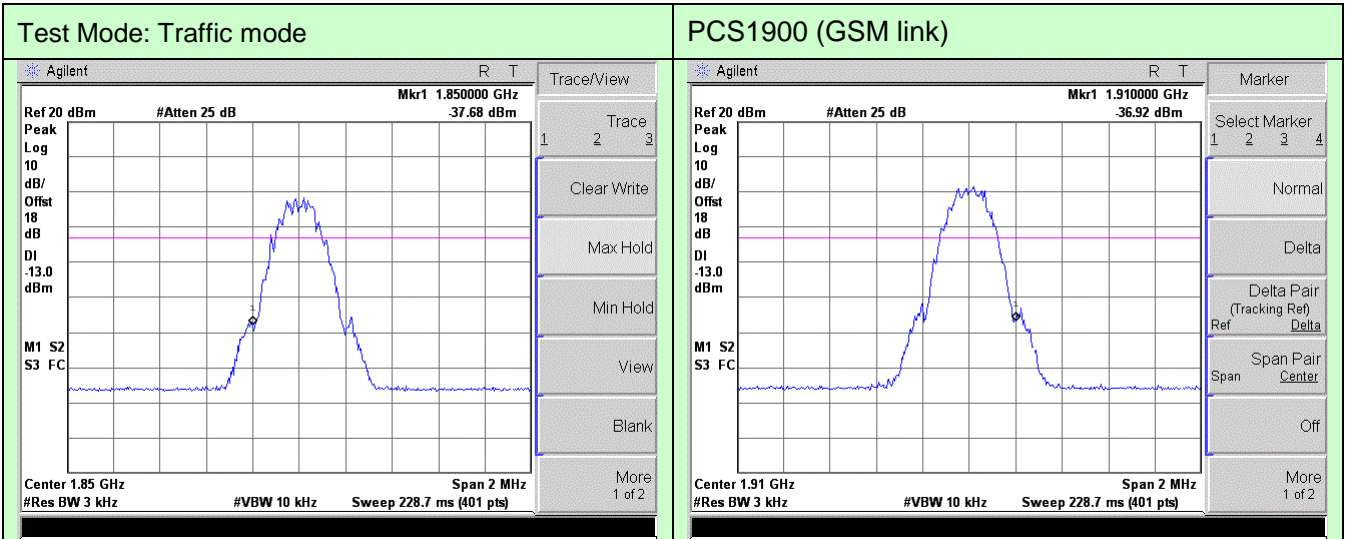

Lowest channel

Highest channel

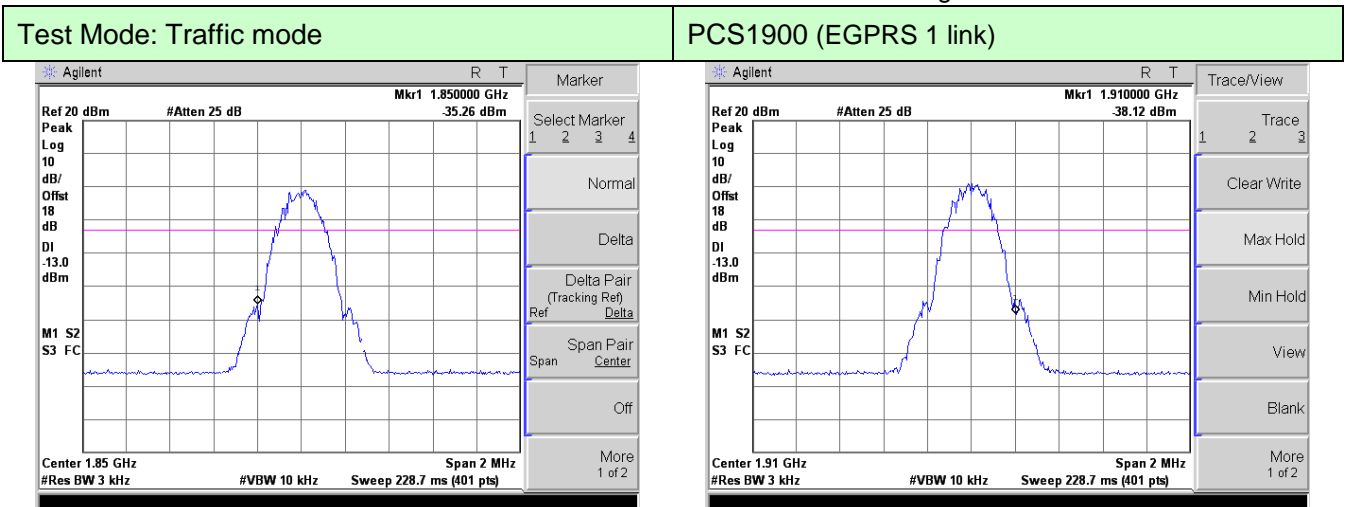

Lowest channel

Highest channel

Test Mode: Traffic mode WCDMA Band V (RMC 12.2Kbps link)

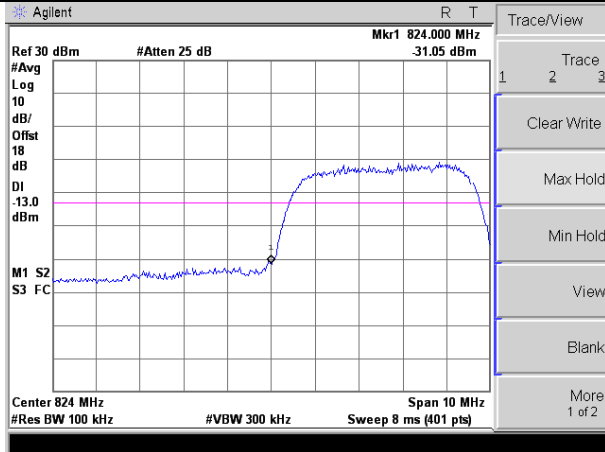

Lowest channel

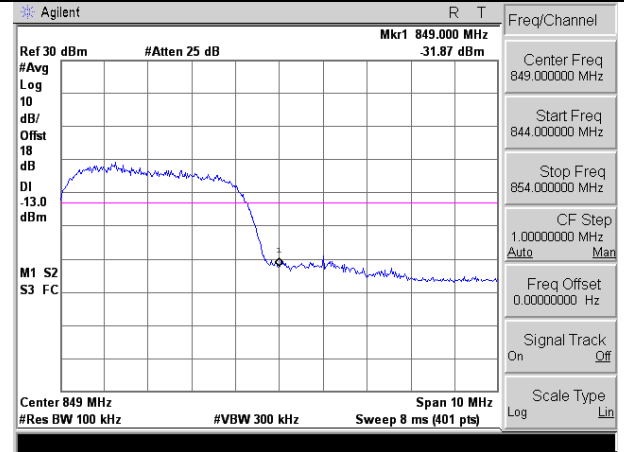

Highest channel

Test Mode: Traffic mode WCDMA Band II (RMC 12.2Kbps link)

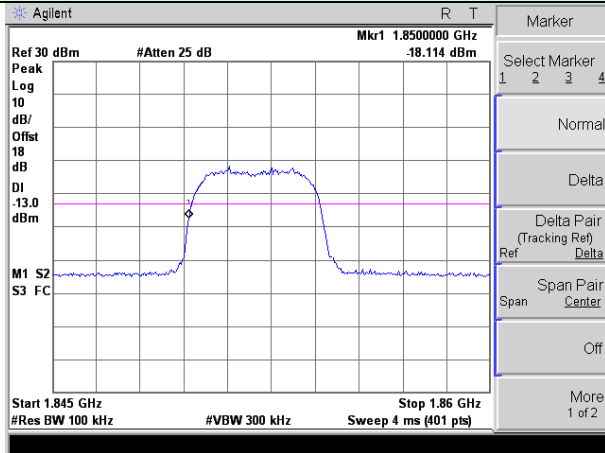

Lowest channel

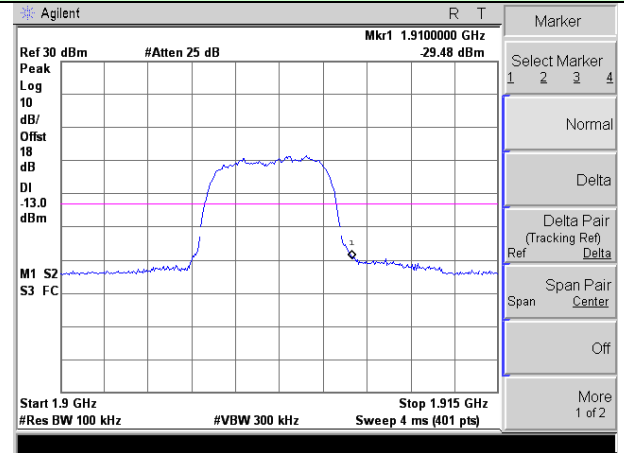

Highest channel

Test Mode: Traffic mode WCDMA Band IV (RMC 12.2Kbps link)

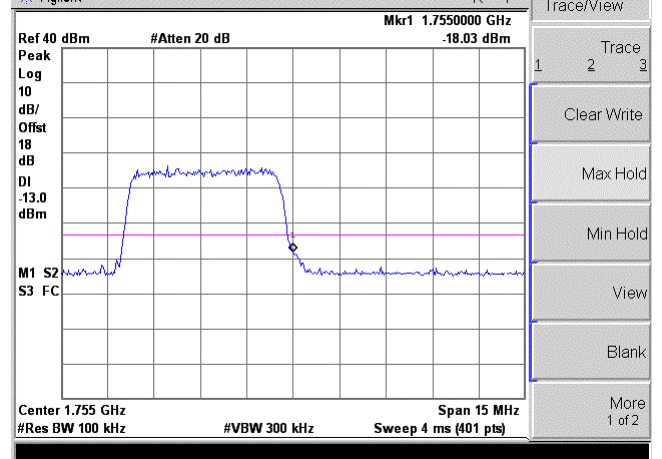
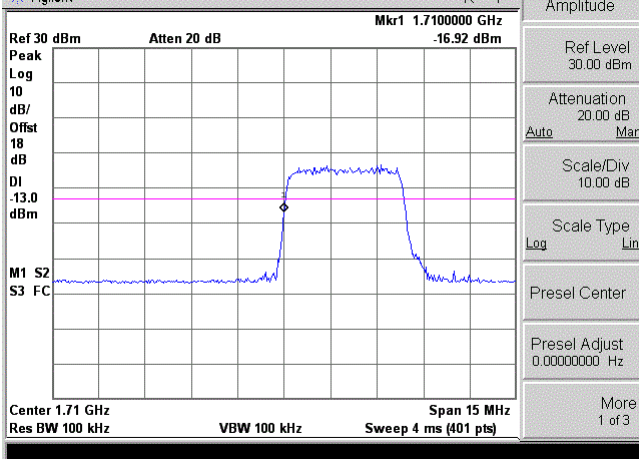

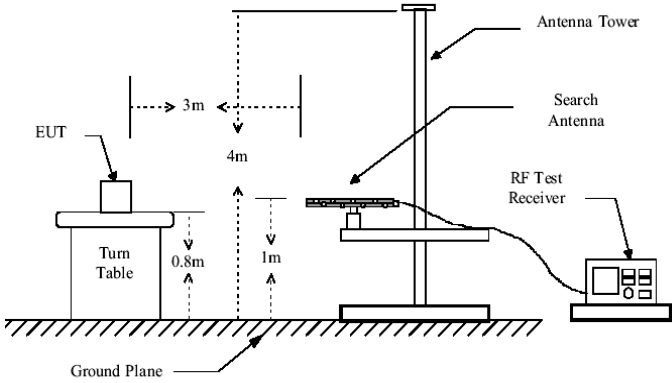
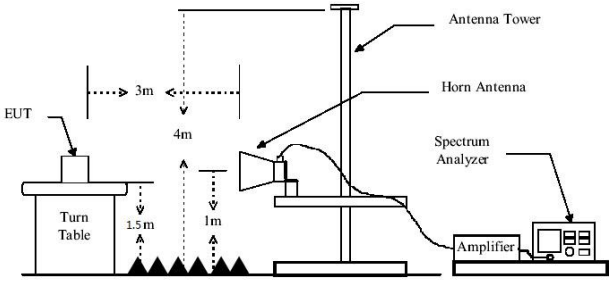
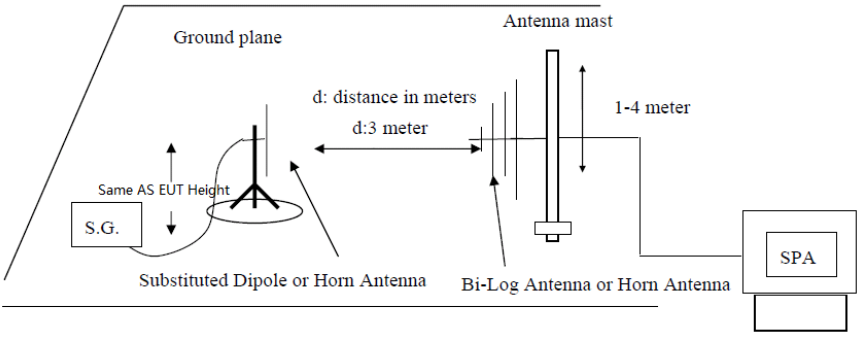

**4.8 ERP, EIRP Measurement**

<p>Test Requirement:</p>	<p>FCC part22.913(a), FCC part24.232(b), FCC part27.50(d)(4), RSS-132 (5.4), RSS-133 (4.1), RSS-139(4.1)</p>
<p>Test Method:</p>	<p>KDB 971168 D01 v03r1 clause 5.8, FCC part2.1051, ANSI/TIA-603-D, ANSI C63.26 clause 5.7</p>
<p>Limit:</p>	<p>GSM850, WCDMA Band V: 7W                  PCS1900, WCDMA Band II: 2W                  WCDMA Band IV: 1W</p>
<p>Test setup:</p>	<p>Below 1GHz</p>  <p>Above 1GHz</p>  <p>Substituted method:</p> 

Test Procedure:	<ol style="list-style-type: none"> <li>1. The EUT was placed on an non-conductive turntable using a non-conductive support. The radiated emission at the fundamental frequency was measured at 3 m with a test antenna and EMI spectrum analyzer.</li> <li>2. During the measurement, the EUT was communication with the station. The highest emission was recorded with the rotation of the turntable and the lowering of the test antenna from 4m to 1m. The reading was recorded and the field strength (E in dBuV/m) was calculated.</li> <li>3. ERP in frequency band 824.2 –848.80.8MHz were measured using a substitution method. The EUT was replaced by dipole antenna connected, the S.G. output was recorded and ERP was calculated asfollows:  <math display="block">\text{ERP} = \text{S.G. output (dBm)} + \text{Antenna Gain (dBd)} - \text{Cable Loss (dB)}</math> </li> <li>4. EIRP in frequency band 1712.6-1752.4, 1850.2 –1909.8MHz were measured using a substitution method. The EUT was replaced by or horn antenna connected, the S.G. output was recorded and EIRP was calculated as follows:  <math display="block">\text{EIRP} = \text{S.G. output (dBm)} + \text{Antenna Gain (dBi)} - \text{Cable Loss (dB)}</math> </li> </ol>
Test Instruments:	Refer to section 3 for details
Test mode:	Refer to section 4.1 for details
Test results:	Pass
Remark:	H,E1,E2 mean for EUT polarization of X, Y, Z

## Measurement Data

EUT mode	Channel	EUT Pol.	Antenna Pol.	ERP(dBm)	Limit (dBm)	Result
GSM850 (GSM link)	Lowest	H	V	25.62	38.45	Pass
			H	28.94		
		E1	V	25.97		
			H	29.41		
		E2	V	25.82		
			H	28.99		
	Middle	H	V	25.15	38.45	Pass
			H	28.44		
		E1	V	25.63		
			H	28.72		
		E2	V	25.71		
			H	28.94		
	Highest	H	V	26.01	38.45	Pass
			H	29.27		
		E1	V	26.05		
			H	29.33		
		E2	V	25.77		
			H	28.62		

EUT mode	Channel	EUT Pol.	Antenna Pol.	ERP(dBm)	Limit (dBm)	Result
GSM850 (GPRS 1 link)	Lowest	H	V	24.91	38.45	Pass
			H	27.96		
		E1	V	24.75		
			H	28.28		
		E2	V	24.35		
			H	28.16		
	Middle	H	V	23.99	38.45	Pass
			H	26.78		
		E1	V	24.57		
			H	27.55		
		E2	V	24.93		
			H	27.65		
	Highest	H	V	24.67	38.45	Pass
			H	27.35		
		E1	V	24.36		
			H	27.83		
		E2	V	24.70		
			H	27.58		

EUT mode	Channel	EUT Pol.	Antenna Pol.	ERP(dBm)	Limit (dBm)	Result
GSM850 (EGPRS 1 link)	Lowest	H	V	19.31	38.45	Pass
			H	23.98		
		E1	V	18.65		
			H	23.45		
		E2	V	19.03		
			H	23.75		
	Middle	H	V	18.83	38.45	Pass
			H	23.70		
		E1	V	19.42		
			H	23.06		
		E2	V	19.60		
			H	23.35		
	Highest	H	V	18.97	38.45	Pass
			H	23.63		
		E1	V	19.10		
			H	23.00		
		E2	V	19.35		
			H	23.65		

EUT mode	Channel	EUT Pol.	Antenna Pol.	EIRP (dBm)	Limit (dBm)	Result
PCS1900 (GSM link)	Lowest	H	V	22.07	33.01	Pass
			H	25.21		
		E1	V	21.25		
			H	25.62		
		E2	V	24.51		
			H	27.72		
	Middle	H	V	24.45	33.01	Pass
			H	27.46		
		E1	V	23.79		
			H	26.22		
		E2	V	23.96		
			H	26.43		
	Highest	H	V	24.12	33.01	Pass
			H	28.69		
		E1	V	24.02		
			H	27.68		
		E2	V	25.23		
			H	28.16		

EUT mode	Channel	EUT Pol.	Antenna Pol.	EIRP (dBm)	Limit (dBm)	Result
PCS1900 (GPRS 1 link)	Lowest	H	V	24.40	33.01	Pass
			H	27.28		
		E1	V	24.45		
			H	27.92		
		E2	V	23.51		
			H	27.27		
	Middle	H	V	23.75	33.01	Pass
			H	25.85		
		E1	V	24.11		
			H	26.89		
		E2	V	24.77		
			H	26.80		
	Highest	H	V	24.44	33.01	Pass
			H	26.50		
		E1	V	24.07		
			H	27.72		
		E2	V	24.17		
			H	27.34		

EUT mode	Channel	EUT Pol.	Antenna Pol.	EIRP (dBm)	Limit (dBm)	Result
PCS1900 (EGPRS 1 link)	Lowest	H	V	23.02	33.01	Pass
			H	25.70		
		E1	V	22.30		
			H	25.35		
		E2	V	21.37		
			H	25.58		
	Middle	H	V	21.12	33.01	Pass
			H	25.38		
		E1	V	22.14		
			H	25.33		
		E2	V	21.09		
			H	24.51		
	Highest	H	V	23.60	33.01	Pass
			H	25.38		
		E1	V	23.90		
			H	25.75		
		E2	V	22.70		
			H	26.17		



EUT mode	Channel	EUT Pol.	Antenna Pol.	ERP(dBm)	Limit (dBm)	Result
WCDMA Band V	Lowest	H	V	16.60	38.45	Pass
			H	20.18		
		E1	V	16.84		
			H	19.33		
		E2	V	15.30		
			H	19.63		
	Middle	H	V	15.70	38.45	Pass
			H	19.30		
		E1	V	17.22		
			H	19.11		
		E2	V	15.06		
			H	18.11		
	Highest	H	V	17.31	38.45	Pass
			H	19.40		
		E1	V	16.65		
			H	20.02		
		E2	V	16.91		
			H	19.86		

EUT mode	Channel	EUT Pol.	Antenna Pol.	EIRP(dBm)	Limit (dBm)	Result
WCDMA Band II	Lowest	H	V	17.73	33.01	Pass
			H	20.81		
		E1	V	17.04		
			H	20.92		
		E2	V	16.92		
			H	20.52		
	Middle	H	V	17.06	33.01	Pass
			H	20.26		
		E1	V	17.21		
			H	19.92		
		E2	V	17.23		
			H	18.66		
	Highest	H	V	18.09	33.01	Pass
			H	21.21		
		E1	V	18.26		
			H	21.67		
		E2	V	18.24		
			H	21.44		

EUT mode	Channel	EUT Pol.	Antenna Pol.	EIRP(dBm)	Limit (dBm)	Result
WCDMA Band IV	Lowest	H	V	17.57	30	Pass
			H	20.57		
		E1	V	16.83		
			H	20.12		
		E2	V	16.15		
			H	20.19		
	Middle	H	V	16.75	30	Pass
			H	19.98		
		E1	V	16.27		
			H	19.04		
		E2	V	16.51		
			H	18.30		
	Highest	H	V	17.47	30	Pass
			H	21.03		
		E1	V	17.29		
			H	20.86		
		E2	V	17.75		
			H	21.10		

### 4.9 Field strength of spurious radiation measurement

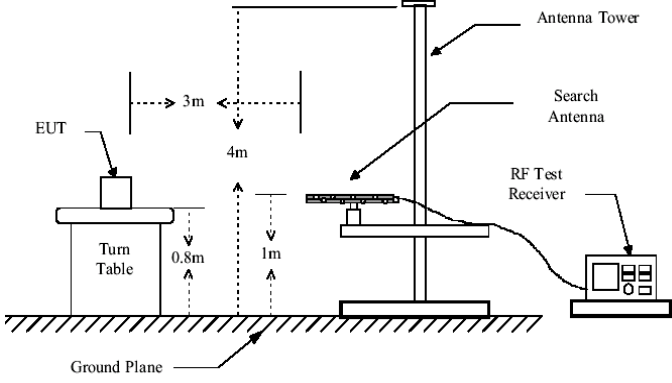
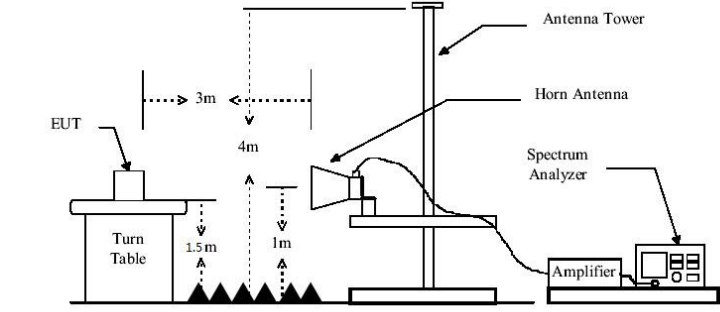
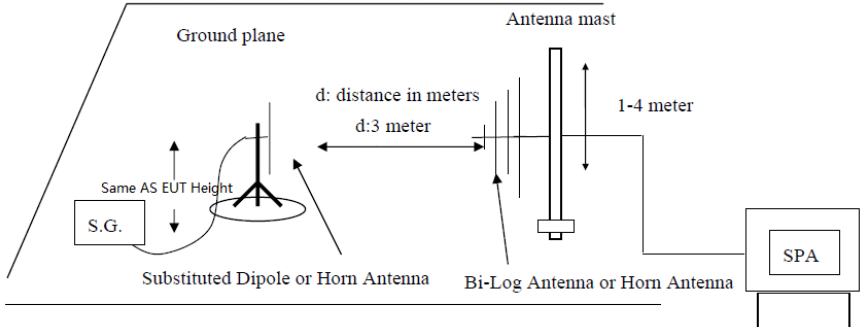
<p>Test Requirement:</p>	<p>FCC part22.917(a), FCC part24.238(a), FCC part27.53(h) RSS-132(5.5), RSS-133(6.5), RSS-139(6.5)</p>
<p>Test Method:</p>	<p>KDB 971168 D01 v03r1 clause 7, FCC part2.1051, ANSI/TIA-603-D, ANSI C63.26 clause 5.5</p>
<p>Limit:</p>	<p>-13dBm</p>
<p>Test setup:</p>	<p>Below 1GHz</p>  <p>Above 1GHz</p>  <p>Substituted method:</p> 

Test Procedure:	<ol style="list-style-type: none"> <li>1. The EUT was placed on an non-conductive turntable using a non-conductive support. The radiated emission at the fundamental frequency was measured at 3 m with a test antenna and EMI spectrum analyzer.</li> <li>2. During the tests, the antenna height and the EUT azimuth were varied in order to identify the maximum level of emissions from the EUT. This maximization process was repeated with the EUT positioned in each of its three orthogonal orientations.</li> <li>3. The frequency range up to tenth harmonic was investigated for each of three fundamental frequency (low, middle and high channels). Once spurious emission was identified, the power of the emission was determined using the substitution method.</li> <li>4. The spurious emissions attenuation was calculated as the difference between radiated power at the fundamental frequency and the spurious emissions frequency.  <math display="block">\text{ERP / EIRP} = \text{S.G. output (dBm)} + \text{Antenna Gain(dB/dBi)} - \text{Cable Loss (dB)}</math> </li> </ol>
Test Instruments:	Refer to section 3 for details
Test mode:	Refer to section 4.1 for details
Test results:	Pass

## Measurement Data

Test mode:	GSM850(GSM)		Test channel:	Lowest
Frequency (MHz)	Spurious Emission		Limit (dBm)	Result
	Polarization	Level (dBm)		
1648.40	Vertical	-47.18	-13.00	Pass
2472.60	V	-47.36		
3296.80	V	-47.64		
4121.00	V	-47.4		
4945.20	V	-46.16		
1648.40	Horizontal	-42.84	-13.00	Pass
2472.60	H	-42.62		
3296.80	H	-42.09		
4121.00	H	-40.38		
4945.20	H	-38.97		
Test mode:	GSM850(GSM)		Test channel:	Middle
Frequency (MHz)	Spurious Emission		Limit (dBm)	Result
	Polarization	Level (dBm)		
1673.20	Vertical	-46.49	-13.00	Pass
2509.80	V	-47.07		
3346.40	V	-47.17		
4183.00	V	-47.45		
5019.60	V	-45.74		
1673.20	Horizontal	-42.34	-13.00	Pass
2509.80	H	-41.89		
3346.40	H	-41.46		
4183.00	H	-40.16		
5019.60	H	-38.94		
Test mode:	GSM850(GSM)		Test channel:	Highest
Frequency (MHz)	Spurious Emission		Limit (dBm)	Result
	Polarization	Level (dBm)		
1697.60	Vertical	-46.60	-13.00	Pass
2546.40	V	-47.21		
3395.20	V	-47.76		
4244.00	V	-46.81		
5092.80	V	-45.47		
1697.60	Horizontal	-42.31	-13.00	Pass
2546.40	H	-42.04		
3395.20	H	-41.89		
4244.00	H	-40.19		
5092.80	H	-38.98		

Remark:

1. The emission behaviour belongs to narrowband spurious emission.
2. Remark"---" means that the emission level is too low to be measured
3. The emission levels of below 1 GHz are 20dB lower than the limit and not show in test report.

Test mode:	GSM850(GPRS)		Test channel:	Lowest
Frequency (MHz)	Spurious Emission		Limit (dBm)	Result
	Polarization	Level (dBm)		
1648.40	Vertical	-46.92	-13.00	Pass
2472.60	V	-47.00		
3296.80	V	-47.58		
4121.00	V	-47.09		
4945.20	V	-45.84		
1648.40	Horizontal	-42.86	-13.00	Pass
2472.60	H	-42.54		
3296.80	H	-42.12		
4121.00	H	-39.57		
4945.20	H	-38.79		
Test mode:	GSM850(GPRS)		Test channel:	Middle
Frequency (MHz)	Spurious Emission		Limit (dBm)	Result
	Polarization	Level (dBm)		
1673.20	Vertical	-46.37	-13.00	Pass
2509.80	V	-46.71		
3346.40	V	-47.79		
4183.00	V	-46.66		
5019.60	V	-45.72		
1673.20	Horizontal	-42.17	-13.00	Pass
2509.80	H	-42.41		
3346.40	H	-41.67		
4183.00	H	-40.25		
5019.60	H	-38.79		
Test mode:	GSM850(GPRS)		Test channel:	Highest
Frequency (MHz)	Spurious Emission		Limit (dBm)	Result
	Polarization	Level (dBm)		
1697.60	Vertical	-46.52	-13.00	Pass
2546.40	V	-47.46		
3395.20	V	-47.27		
4244.00	V	-47.14		
5092.80	V	-46.11		
1697.60	Horizontal	-42.17	-13.00	Pass
2546.40	H	-42.40		
3395.20	H	-41.66		
4244.00	H	-39.55		
5092.80	H	-39.13		

Remark :

1. The emission behaviour belongs to narrowband spurious emission.
2. Remark"---" means that the emission level is too low to be measured
3. The emission levels of below 1 GHz are 20dB lower than the limit and not show in test report.

Test mode:	GSM850(EGPRS)		Test channel:	Lowest
Frequency (MHz)	Spurious Emission		Limit (dBm)	Result
	Polarization	Level (dBm)		
1648.40	Vertical	-47.34	-13.00	Pass
2472.60	V	-47.47		
3296.80	V	-47.39		
4121.00	V	-46.62		
4945.20	V	-45.59		
1648.40	Horizontal	-42.33	-13.00	Pass
2472.60	H	-42.36		
3296.80	H	-41.60		
4121.00	H	-39.85		
4945.20	H	-39.01		
Test mode:	GSM850(EGPRS)		Test channel:	Middle
Frequency (MHz)	Spurious Emission		Limit (dBm)	Result
	Polarization	Level (dBm)		
1673.20	Vertical	-47.02	-13.00	Pass
2509.80	V	-47.45		
3346.40	V	-47.47		
4183.00	V	-46.77		
5019.60	V	-45.52		
1673.20	Horizontal	-42.73	-13.00	Pass
2509.80	H	-41.99		
3346.40	H	-41.30		
4183.00	H	-40.23		
5019.60	H	-38.55		
Test mode:	GSM850(EGPRS)		Test channel:	Highest
Frequency (MHz)	Spurious Emission		Limit (dBm)	Result
	Polarization	Level (dBm)		
1697.60	Vertical	-46.58	-13.00	Pass
2546.40	V	-47.27		
3395.20	V	-46.90		
4244.00	V	-46.81		
5092.80	V	-45.42		
1697.60	Horizontal	-42.62	-13.00	Pass
2546.40	H	-42.77		
3395.20	H	-41.57		
4244.00	H	-40.27		
5092.80	H	-38.92		

Remark :

1. The emission behaviour belongs to narrowband spurious emission.
2. Remark"---" means that the emission level is too low to be measured
3. The emission levels of below 1 GHz are 20dB lower than the limit and not show in test report.



Test mode:	PCS1900(GSM)		Test channel:	Lowest
Frequency (MHz)	Spurious Emission		Limit (dBm)	Result
	Polarization	Level (dBm)		
3700.40	Vertical	-45.21	-13.00	Pass
5550.60	V	-44.84		
7400.80	V	-44.34		
9251.00	V	-43.20		
11101.20	V	-42.75		
3700.40	Horizontal	-41.20	-13.00	Pass
5550.60	H	-38.21		
7400.80	H	-38.25		
9251.00	H	-37.23		
11101.20	H	-35.67		
Test mode:	PCS1900(GSM)		Test channel:	Middle
Frequency (MHz)	Spurious Emission		Limit (dBm)	Result
	Polarization	Level (dBm)		
3760.00	Vertical	-44.80	-13.00	Pass
5640.00	V	-44.96		
7520.00	V	-44.30		
9400.00	V	-42.67		
11280.00	V	-43.13		
3760.00	Horizontal	-41.16	-13.00	Pass
5640.00	H	-38.79		
7520.00	H	-38.10		
9400.00	H	-37.00		
11280.00	H	-35.67		
Test mode:	PCS1900(GSM)		Test channel:	Highest
Frequency (MHz)	Spurious Emission		Limit (dBm)	Result
	Polarization	Level (dBm)		
3819.60	Vertical	-44.51	-13.00	Pass
5729.40	V	-44.77		
7639.20	V	-44.14		
9549.00	V	-43.42		
11458.80	V	-43.21		
3819.60	Horizontal	-41.56	-13.00	Pass
5729.40	H	-38.02		
7639.20	H	-38.00		
9549.00	H	-36.94		
11458.80	H	-35.78		

Remark:

1. The emission behaviour belongs to narrowband spurious emission.
2. Remark"---" means that the emission level is too low to be measured
3. The emission levels of below 1 GHz are 20dB lower than the limit and not show in test report.

Test mode:	PCS1900(GPRS)		Test channel:	Lowest
Frequency (MHz)	Spurious Emission		Limit (dBm)	Result
	Polarization	Level (dBm)		
3700.40	Vertical	-44.39	-13.00	Pass
5550.60	V	-45.45		
7400.80	V	-44.52		
9251.00	V	-42.93		
11101.20	V	-42.71		
3700.40	Horizontal	-41.76	-13.00	Pass
5550.60	H	-38.36		
7400.80	H	-38.11		
9251.00	H	-37.47		
11101.20	H	-35.22		
Test mode:	PCS1900(GPRS)		Test channel:	Middle
Frequency (MHz)	Spurious Emission		Limit (dBm)	Result
	Polarization	Level (dBm)		
3760.00	Vertical	-45.23	-13.00	Pass
5640.00	V	-45.37		
7520.00	V	-44.13		
9400.00	V	-43.36		
11280.00	V	-42.49		
3760.00	Horizontal	-41.12	-13.00	Pass
5640.00	H	-38.37		
7520.00	H	-38.15		
9400.00	H	-36.70		
11280.00	H	-35.60		
Test mode:	PCS1900(GPRS)		Test channel:	Highest
Frequency (MHz)	Spurious Emission		Limit (dBm)	Result
	Polarization	Level (dBm)		
3819.60	Vertical	-44.73	-13.00	Pass
5729.40	V	-44.97		
7639.20	V	-44.68		
9549.00	V	-43.55		
11458.80	V	-42.93		
3819.60	Horizontal	-41.04	-13.00	Pass
5729.40	H	-38.77		
7639.20	H	-37.97		
9549.00	H	-37.53		
11458.80	H	-35.78		

Remark:

4. The emission behaviour belongs to narrowband spurious emission.
5. Remark"---" means that the emission level is too low to be measured
6. The emission levels of below 1 GHz are 20dB lower than the limit and not show in test report.

Test mode:	PCS1900(EGPRS)		Test channel:	Lowest
Frequency (MHz)	Spurious Emission		Limit (dBm)	Result
	Polarization	Level (dBm)		
3700.40	Vertical	-44.44	-13.00	Pass
5550.60	V	-45.23		
7400.80	V	-44.12		
9251.00	V	-43.17		
11101.20	V	-43.20		
3700.40	Horizontal	-41.25	-13.00	Pass
5550.60	H	-37.88		
7400.80	H	-37.40		
9251.00	H	-36.89		
11101.20	H	-35.45		
Test mode:	PCS1900(EGPRS)		Test channel:	Middle
Frequency (MHz)	Spurious Emission		Limit (dBm)	Result
	Polarization	Level (dBm)		
3760.00	Vertical	-44.75	-13.00	Pass
5640.00	V	-45.18		
7520.00	V	-44.52		
9400.00	V	-42.81		
11280.00	V	-42.48		
3760.00	Horizontal	-41.62	-13.00	Pass
5640.00	H	-37.85		
7520.00	H	-37.37		
9400.00	H	-37.48		
11280.00	H	-36.00		
Test mode:	PCS1900(EGPRS)		Test channel:	Highest
Frequency (MHz)	Spurious Emission		Limit (dBm)	Result
	Polarization	Level (dBm)		
3819.60	Vertical	-44.99	-13.00	Pass
5729.40	V	-45.20		
7639.20	V	-44.64		
9549.00	V	-42.86		
11458.80	V	-42.39		
3819.60	Horizontal	-41.27	-13.00	Pass
5729.40	H	-38.37		
7639.20	H	-37.28		
9549.00	H	-37.43		
11458.80	H	-35.56		

Remark:

1. The emission behaviour belongs to narrowband spurious emission.
2. Remark"---" means that the emission level is too low to be measured
3. The emission levels of below 1 GHz are 20dB lower than the limit and not show in test report.

Test mode:	WCDMA Band V		Test channel:	Lowest
Frequency (MHz)	Spurious Emission		Limit (dBm)	Result
	Polarization	Level (dBm)		
1652.80	Vertical	-47.04	-13.00	Pass
2479.20	V	-47.49		
3305.60	V	-47.66		
4132.00	V	-47.52		
4958.40	V	-46.10		
1652.80	Horizontal	-42.07	-13.00	Pass
2479.20	H	-41.48		
3305.60	H	-41.34		
4132.00	H	-40.55		
4958.40	H	-40.81		
Test mode:	WCDMA Band V		Test channel:	Middle
Frequency (MHz)	Spurious Emission		Limit (dBm)	Result
	Polarization	Level (dBm)		
1672.80	Vertical	-47.44	-13.00	Pass
2509.20	V	-47.11		
3345.60	V	-47.63		
4182.00	V	-47.18		
5018.40	V	-46.59		
1672.80	Horizontal	-42.15	-13.00	Pass
2509.20	H	-42.01		
3345.60	H	-40.84		
4182.00	H	-41.06		
5018.40	H	-40.10		
Test mode:	WCDMA Band V		Test channel:	Highest
Frequency (MHz)	Spurious Emission		Limit (dBm)	Result
	Polarization	Level (dBm)		
1693.20	Vertical	-47.68	-13.00	Pass
2539.80	V	-47.13		
3386.40	V	-47.41		
4233.00	V	-47.54		
5079.60	V	-45.99		
1693.20	Horizontal	-41.43	-13.00	Pass
2539.80	H	-41.40		
3386.40	H	-40.66		
4233.00	H	-41.07		
5079.60	H	-40.36		

Remark :

1. The emission behaviour belongs to narrowband spurious emission.
2. Remark"---" means that the emission level is too low to be measured
3. The emission levels of below 1 GHz are 20dB lower than the limit and not show in test report.

Test mode:	WCDMA Band II		Test channel:	Lowest
Frequency (MHz)	Spurious Emission		Limit (dBm)	Result
	Polarization	Level (dBm)		
3704.80	Vertical	-45.07	-13.00	Pass
5557.20	V	-45.14		
7409.60	V	-44.70		
9262.00	V	-42.58		
11114.40	V	-42.90		
3704.80	Horizontal	-41.75	-13.00	Pass
5557.20	H	-38.43		
7409.60	H	-37.67		
9262.00	H	-36.96		
11114.40	H	-35.65		
Test mode:	WCDMA Band II		Test channel:	Middle
Frequency (MHz)	Spurious Emission		Limit (dBm)	Result
	Polarization	Level (dBm)		
3760.00	Vertical	-45.07	-13.00	Pass
5640.00	V	-45.45		
7520.00	V	-44.55		
9400.00	V	-43.51		
11280.00	V	-42.43		
3760.00	Horizontal	-41.13	-13.00	Pass
5640.00	H	-38.79		
7520.00	H	-37.59		
9400.00	H	-37.26		
11280.00	H	-35.17		
Test mode:	WCDMA Band II		Test channel:	Highest
Frequency (MHz)	Spurious Emission		Limit (dBm)	Result
	Polarization	Level (dBm)		
3815.20	Vertical	-45.32	-13.00	Pass
5722.80	V	-44.71		
7630.40	V	-44.20		
9538.00	V	-43.48		
11445.60	V	-42.58		
3815.20	Horizontal	-41.18	-13.00	Pass
5722.80	H	-38.36		
7630.40	H	-37.86		
9538.00	H	-37.54		
11445.60	H	-35.46		

Remark:

1. The emission behaviour belongs to narrowband spurious emission.
2. Remark"---" means that the emission level is too low to be measured
3. The emission levels of below 1 GHz are 20dB lower than the limit and not show in test report.

Test mode:	WCDMA Band IV		Test channel:	Lowest
Frequency (MHz)	Spurious Emission		Limit (dBm)	Result
	Polarization	Level (dBm)		
3425.20	Vertical	-44.53	-13.00	Pass
5137.80	V	-44.74		
6850.40	V	-44.09		
8563.00	V	-42.68		
10275.60	V	-42.55		
3425.20	Horizontal	-41.39	-13.00	Pass
5137.80	H	-37.92		
6850.40	H	-37.53		
8563.00	H	-37.47		
10275.60	H	-35.97		
Test mode:	WCDMA Band IV		Test channel:	Middle
Frequency (MHz)	Spurious Emission		Limit (dBm)	Result
	Polarization	Level (dBm)		
3465.20	Vertical	-44.35	-13.00	Pass
5197.80	V	-45.16		
6930.40	V	-43.88		
8663.00	V	-43.18		
10395.60	V	-42.95		
3465.20	Horizontal	-41.22	-13.00	Pass
5197.80	H	-37.95		
6930.40	H	-37.95		
8663.00	H	-36.68		
10395.60	H	-35.78		
Test mode:	WCDMA Band IV		Test channel:	Highest
Frequency (MHz)	Spurious Emission		Limit (dBm)	Result
	Polarization	Level (dBm)		
3504.80	Vertical	-44.38	-13.00	Pass
5257.20	V	-44.85		
7009.60	V	-44.39		
8762.00	V	-42.97		
10514.40	V	-42.54		
3504.80	Horizontal	-42.00	-13.00	Pass
5257.20	H	-37.84		
7009.60	H	-37.89		
8762.00	H	-37.53		
10514.40	H	-35.73		

Remark:

1. The emission behaviour belongs to narrowband spurious emission.
2. Remark"---" means that the emission level is too low to be measured
3. The emission levels of below 1 GHz are 20dB lower than the limit and not show in test report.

#### 4.10 Frequency stability V.S. Temperature measurement

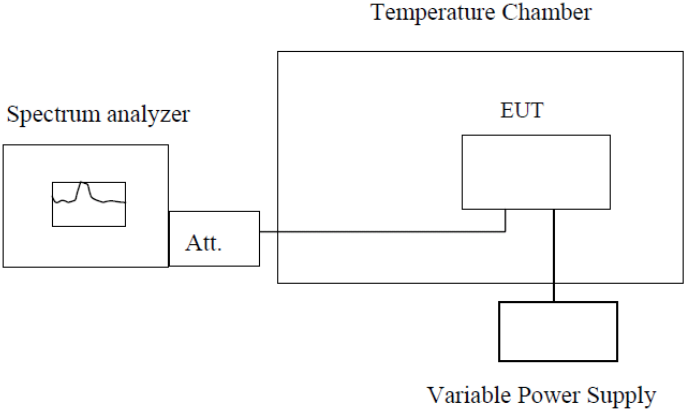
Test Requirement:	Part 2.1055(a)(1)(b), Part 22.355, Part 24.235, Part 27.54 RSS-132(5.3), RSS-133 (6.3), RSS-139 (6.4)
Test Method:	FCC Part2.1055(d)(1)(2), ANSI/TIA-603-D FCC KDB971168 D01 v03r01 Section 8, ANSI C63.26 clause 5.6.
Limit:	2.5ppm (Band V) Within the authorized bands of operation(Band II, Band IV)
Test setup:	<p style="text-align: center;">Temperature Chamber</p>  <p style="text-align: center;">Variable Power Supply</p> <p><b>Note :</b> Measurement setup for testing on Antenna connector</p>
Test procedure:	<ol style="list-style-type: none"> <li>1. The equipment under test was connected to an external DC power supply and input rated voltage.</li> <li>2. RF output was connected to a frequency counter or spectrum analyzer via feed through attenuators.</li> <li>3. The EUT was placed inside the temperature chamber.</li> <li>4. Set the spectrum analyzer RBW low enough to obtain the desired frequency resolution and measure EUT 20°C operating frequency as reference frequency.</li> <li>5. Turn EUT off and set the chamber temperature to –20°C. After the temperature stabilized for approximately 30 minutes recorded the frequency.</li> <li>6. Repeat step measure with 10°C increased per stage until the highest temperature of +50°C reached.</li> </ol>
Test Instruments:	Refer to section 3 for details
Test mode:	Refer to section 4.1 for details
Test results:	Pass
Remark:	If all frequencies stability are comply with the lower limit, then all results can be considered qualified

Measurement Data

Reference Frequency: GSM850 (GSM link) Middle channel=190 channel=836.6MHz					
Power supplied (Vdc)	Temperature (°C)	Frequency error		Limit (ppm)	Result
		Hz	ppm		
7.2	-30	8	0.0094	2.5	Pass
	-20	28	0.0340		
	-10	14	0.0173		
	0	8	0.0097		
	10	15	0.0175		
	20	9	0.0109		
	30	21	0.0246		
	40	25	0.0294		
	50	21	0.0257		
Reference Frequency: GSM850 (GPRS 1 link) Middle channel=190 channel=836.6MHz					
Power supplied (Vdc)	Temperature (°C)	Frequency error		Limit (ppm)	Result
		Hz	ppm		
7.2	-30	12	0.0148	2.5	Pass
	-20	25	0.0294		
	-10	13	0.0160		
	0	16	0.0189		
	10	8	0.0101		
	20	9	0.0111		
	30	18	0.0221		
	40	29	0.0342		
	50	17	0.0207		
Reference Frequency: GSM850 (EGPRS 1 link) Middle channel=190 channel=836.6MHz					
Power supplied (Vdc)	Temperature (°C)	Frequency error		Limit (ppm)	Result
		Hz	ppm		
7.2	-30	11	0.0128	2.5	Pass
	-20	27	0.0326		
	-10	15	0.0176		
	0	8	0.0097		
	10	12	0.0147		
	20	11	0.0135		
	30	26	0.0316		
	40	27	0.0319		
	50	17	0.0204		



Reference Frequency: PCS1900 (GSM link) Middle channel=661 channel=1880MHz					
Power supplied (Vdc)	Temperature (°C)	Frequency error			Result
		Hz	ppm		
7.2	-30	31	0.0163	2.5	Pass
	-20	52	0.0274		
	-10	28	0.0150		
	0	36	0.0190		
	10	32	0.0168		
	20	26	0.0137		
	30	46	0.0245		
	40	32	0.0172		
	50	38	0.0200		
Reference Frequency: PCS1900 (GPRS 1 link) Middle channel=661 channel=1880MHz					
Power supplied (Vdc)	Temperature (°C)	Frequency error			Result
		Hz	ppm		
7.2	-30	28	0.0147	2.5	Pass
	-20	52	0.0277		
	-10	33	0.0176		
	0	36	0.0194		
	10	24	0.0127		
	20	27	0.0142		
	30	49	0.0260		
	40	35	0.0189		
	50	38	0.0203		
Reference Frequency: PCS1900 (EGPRS 1 link) Middle channel=661 channel=1880MHz					
Power supplied (Vdc)	Temperature (°C)	Frequency error			Result
		Hz	ppm		
7.2	-30	28	0.0148	2.5	Pass
	-20	52	0.0278		
	-10	29	0.0157		
	0	28	0.0147		
	10	27	0.0141		
	20	18	0.0097		
	30	47	0.0247		
	40	32	0.0169		
	50	31	0.0163		

Reference Frequency: WCDMA Band V Middle channel=4183 channel=836.6MHz					
Power supplied (Vdc)	Temperature (°C)	Frequency error		Limit (ppm)	Result
		Hz	ppm		
7.2	-30	9	0.0107	2.5	Pass
	-20	18	0.0217		
	-10	4	0.0042		
	0	15	0.0184		
	10	3	0.0038		
	20	7	0.0078		
	30	9	0.0108		
	40	22	0.0268		
	50	16	0.0190		
Reference Frequency: WCDMA Band II Middle channel=9400 channel=1880.0MHz					
Power supplied (Vdc)	Temperature (°C)	Frequency error		Limit (ppm)	Result
		Hz	ppm		
7.2	-30	33	0.0174	2.5	Pass
	-20	52	0.0276		
	-10	36	0.0191		
	0	33	0.0178		
	10	28	0.0147		
	20	26	0.0141		
	30	45	0.0237		
	40	35	0.0187		
	50	38	0.0201		
Reference Frequency: WCDMA Band IV Middle channel=1413 channel=1732.6MHz					
Power supplied (Vdc)	Temperature (°C)	Frequency error		Limit (ppm)	Result
		Hz	ppm		
7.2	-30	29	0.0181	2.5	Pass
	-20	43	0.0263		
	-10	35	0.0199		
	0	25	0.0163		
	10	20	0.0127		
	20	24	0.0142		
	30	35	0.0219		
	40	31	0.0147		
	50	34	0.0164		

#### 4.11 Frequency stability V.S. Voltage measurement

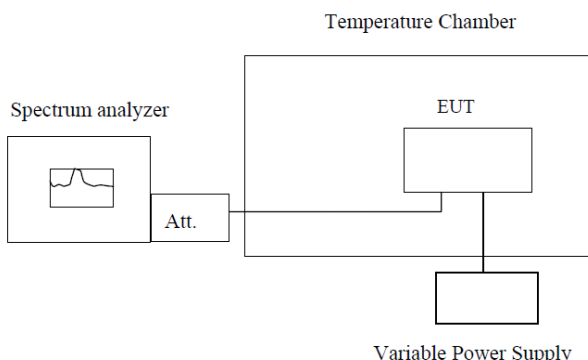
Test Requirement:	Part 2.1055(d)(1)(2), Part 22.355, Part 24.235, Part 27.54 RSS-132(5.3), RSS-133 (6.3), RSS-139 (6.4)
Test Method:	FCC Part2.1055(d)(1)(2), ANSI/TIA-603-D FCC KDB971168 D01 v03r01 Section 8, ANSI C63.26 clause 5.6.
Limit:	2.5ppm (Band V) Within the authorized bands of operation(Band II, Band IV)
Test setup:	 <p style="text-align: center;">Temperature Chamber</p> <p style="text-align: center;">Spectrum analyzer      Att.      EUT</p> <p style="text-align: center;">Variable Power Supply</p> <p><b>Note :</b> Measurement setup for testing on Antenna connector</p>
Test procedure:	<ol style="list-style-type: none"> <li>1. Set chamber temperature to 20°C. Use a variable DC power source to power the EUT and set the voltage to rated voltage.</li> <li>2. Set the spectrum analyzer RBW low enough to obtain the desired frequency resolution and recorded the frequency.</li> <li>3. Reduce the input voltage to specified extreme voltage variation (+/- 15%) and endpoint, record the maximum frequency change.</li> </ol>
Test Instruments:	Refer to section 3 for details
Test mode:	Refer to section 4.1 for details
Test results:	Pass
Remark:	<ol style="list-style-type: none"> <li>1. Manufacturer specified the battery operating end point voltage is 6.1VDC, max voltage is 8.3VDC.</li> <li>2. If all frequencies stability are comply with the lower limit, then all results can be considered qualified</li> </ol>

## Measurement Data

Reference Frequency: GSM850 (GSM link) Middle channel=190 channel=836.6MHz					
Temperature (°C)	Power supplied (Vdc)	Frequency error		Limit (ppm)	Result
		Hz	ppm		
20	8.3	21	0.0246	2.5	Pass
	7.2	27	0.0323		
	6.1	19	0.0230		
Reference Frequency: GSM850 (GPRS 1 link) Middle channel=190 channel=836.6MHz					
Temperature (°C)	Power supplied (Vdc)	Frequency error		Limit (ppm)	Result
		Hz	ppm		
20	8.3	29	0.0341	2.5	Pass
	7.2	32	0.0383		
	6.1	28	0.0332		
Reference Frequency: GSM850 (EGPRS 1 link) Middle channel=190 channel=836.6MHz					
Temperature (°C)	Power supplied (Vdc)	Frequency error		Limit (ppm)	Result
		Hz	ppm		
20	8.3	24	0.0289	2.5	Pass
	7.2	34	0.0405		
	6.1	28	0.0331		

Reference Frequency: PCS1900 (GSM link) Middle channel=661 channel=1880MHz					
Temperature (°C)	Power supplied (Vdc)	Frequency error		Limit (ppm)	Result
		Hz	ppm		
25	8.3	31	0.0164	2.5	Pass
	7.2	34	0.0178		
	6.1	37	0.0196		
Reference Frequency: PCS1900 (GPRS 1 link) Middle channel=661 channel=1880MHz					
Temperature (°C)	Power supplied (Vdc)	Frequency error		Limit (ppm)	Result
		Hz	ppm		
25	8.3	31	0.0168	2.5	Pass
	7.2	32	0.0172		
	6.1	29	0.0153		
Reference Frequency: PCS1900 (EGPRS 1 link) Middle channel=661 channel=1880MHz					
Temperature (°C)	Power supplied (Vdc)	Frequency error		Limit (ppm)	Result
		Hz	ppm		
25	8.3	25	0.0135	2.5	Pass
	7.2	31	0.0163		
	6.1	35	0.0184		

Reference Frequency: WCDMA Band V Middle channel=4183 channel=836.6MHz					
Temperature (°C)	Power supplied (Vdc)	Frequency error		Limit (ppm)	Result
		Hz	ppm		
25	8.3	22	0.0258	2.5	Pass
	7.2	32	0.0379		
	6.1	21	0.0255		
Reference Frequency: WCDMA Band II Middle channel=940 channel=1880.0MHz					
Temperature (°C)	Power supplied (Vdc)	Frequency error		Limit (ppm)	Result
		Hz	ppm		
25	8.3	33	0.0174	2.5	Pass
	7.2	33	0.0173		
	6.1	30	0.0158		
Reference Frequency: WCDMA Band IV Middle channel=1413 channel=1732.6MHz					
Temperature (°C)	Power supplied (Vdc)	Frequency error		Limit (ppm)	Result
		Hz	ppm		
25	8.3	28	0.0162	2.5	Pass
	7.2	25	0.0144		
	6.1	29	0.0167		

-----THE END OF REPORT-----