



FCC&IC TEST REPORT

FCC ID: 2ABNA-P9IIHH, IC: 11648A-P9IIHH

On Behalf of

Guangzhou Geoelectron Science & Technology Company

Limited

P9II Handheld

Model No.: P9II PRO, P9II STD

Prepared for : Guangzhou Geoelectron Science & Technology Company Limited
Address : No.704, 7/F, Building C, No.7, Cai Pin Road, Science City, Luogang
District, Guangzhou, China

Prepared By : Shenzhen Alpha Product Testing Co., Ltd.
Address : Building i, No.2, Lixin Road, Fuyong Street, Bao'an District, 518103,
Shenzhen, Guangdong, China

Report Number : T1881637 22
Date of Receipt : October 23, 2018
Date of Test : October 23, 2018-December 27, 2018
Date of Report : February 04, 2019
Version Number : REV0

TABLE OF CONTENTS

Description	Page
1. Summary of Standards And Results-----	6
1.1. Description of Standards and Results -----	6
2. General Information -----	7
2.1. Description of Device (EUT)-----	7
2.2. Accessories of Device (EUT) -----	8
2.3. Tested Supporting System Details -----	8
2.4. Block Diagram of connection between EUT and simulators -----	8
2.5. Test Mode Description -----	9
2.6. Test Conditions -----	10
2.7. Test Facility -----	10
2.8. Measurement Uncertainty -----	11
2.9. Test Equipment List -----	12
3. Spurious Emission -----	13
3.1. Test Limits -----	13
3.2. Test Procedure -----	16
3.3. Test Setup -----	16
3.4. Test Results -----	17
4. Power line Conducted Emission -----	25
4.1. Test Limits -----	25
4.2. Test Procedure -----	25
4.3. Test Setup -----	25
4.4. Test Results -----	26
5. Conducted Maximum Output Power -----	28
5.1. Test limits -----	28
5.2. Test Procedure -----	28
5.3. Test Setup -----	28
5.4. Test Results -----	28
6. Peak Power Spectral Density-----	30
6.1. Test limits -----	30
6.2. Test Procedure -----	30
6.3. Test Setup -----	30
6.4. Test Results -----	31
7. Bandwidth-----	34
7.1. Test limits -----	34
7.2. Test Procedure -----	34
7.3. Test Setup -----	34
7.4. Test Results -----	34
8. Band Edge Check-----	38
8.1. Test limits -----	38
8.2. Test Procedure -----	38
8.3. Test Setup -----	38
8.4. Test Results -----	38
9. Frequency stability -----	45

- 9.1. Test limit ----- 45
- 9.2. Test Procedure ----- 45
- 9.3. Test Setup ----- 45
- 9.4. Test Results ----- 45
- 10. Antenna Requirement ----- 47**
- 10.1. Standard Requirement ----- 47
- 10.2. Antenna Connected Construction ----- 47
- 10.3. Results ----- 47

TEST REPORT DECLARATION

Applicant : Guangzhou Geoelectron Science & Technology Company Limited
 Address : No.704, 7/F, Building C, No.7, Cai Pin Road, Science City, Luogang District, Guangzhou, China
 Manufacturer : Guangzhou Geoelectron Science & Technology Company Limited
 Address : No.704, 7/F, Building C, No.7, Cai Pin Road, Science City, Luogang District, Guangzhou, China
 EUT Description : P9II Handheld
 (A) Model No. : P9II PRO, P9II STD
 (B) Trademark : N/A

Measurement Standard Used:

FCC Rules and Regulations Part 15 Subpart C Section 15.247: 2017, RSS-247 Issue 2, RSS-Gen Issue 5, ANSI C63.10:2013, CISPR 16-1-4:2010

The device described above is tested by Shenzhen Alpha Product Testing Co., Ltd. to determine the maximum emission levels emanating from the device. The maximum emission levels are compared to the FCC Part 15 Subpart C limits both conducted and radiated emissions. The test results are contained in this test report and Shenzhen Alpha Product Testing Co., Ltd. is assumed of full responsibility for the accuracy and completeness of these tests.

After the test, our opinion is that EUT compliance with the requirement of the above standards.

This report applies to above tested sample only. This report shall not be reproduced in parts without written approval of Shenzhen Alpha Product Testing Co., Ltd.

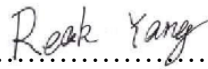
Tested by (name + signature).....: Reak Yang 

Project Engineer

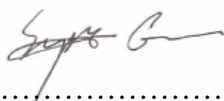
Approved by (name + signature).....: Simple Guan 

Project Manager

Date of issue.....: February 04, 2019

Revision History

Revision	Issue Date	Revisions	Revised By
00	February 04, 2019	Initial released Issue	Simple Guan

1. SUMMARY OF STANDARDS AND RESULTS

1.1. Description of Standards and Results

The EUT have been tested according to the applicable standards as referenced below:

Test Item	Standards Paragraph	Result
Conducted Emission	FCC Part 15: 15.207 RSS-GEN(8.8) ANSI C63.10 :2013	P
6dB Bandwidth	FCC PART 15:15.247(a)(2) RSS-247(5.2 a) ANSI C63.10 :2013	P
Output Power	FCC Part 15: 15.247(b)(3) RSS-247(5.4 d) ANSI C63.10 :2013	P
Radiated Spurious Emission	FCC Part 15: 15.209 FCC Part 15: 15.247(d) RSS-Gen(8.9), RSS-247(5.5) ANSI C63.10 :2013	P
Conducted Spurious & Band Edge Emission	FCC Part 15: 15.247(d) RSS-Gen(8.9), RSS-247(5.5) ANSI C63.10 :2013	P
Power Spectral Density	FCC PART 15:15.247(e) RSS-247(5.2 b) ANSI C63.10 :2013	P
Radiated Band Edge Emission	FCC Part 15: 15.247(d) RSS-GEN(6.13) ANSI C63.10 :2013	P
Frequency stability	RSS-GEN(6.11)	P
Antenna Requirement	FCC Part 15: 15.203 RSS-GEN(6.8)	P
Note:	1. P is an abbreviation for Pass. 2. F is an abbreviation for Fail. 3. N/A is an abbreviation for Not Applicable.	

2. GENERAL INFORMATION

2.1. Description of Device (EUT)

Description/PMN	:	P9II Handheld
Model Number/HVIN(s) Diff.	:	P9II PRO, P9II STD They are all the same, except that P9II PRO with M8T GPS receiver, P9II STD without M8T GPS receiver, the result of this report belongs to P9II PRO.
Trademark	:	N/A
Test Voltage	:	DC 7.2V from battery, DC 15V For Charging
Operation frequency	:	2412MHz-2462MHz for IEEE 802.11 b, g, n/HT20 2422MHz-2452MHz for IEEE 802.11 n/HT40
Channel No.	:	802.11b/802.11g /802.11n(HT20): 11 802.11n(HT40): 7
Modulation type	:	IEEE 802.11b: DSSS(CCK,DQPSK,DBPSK) IEEE 802.11g: OFDM(64QAM, 16QAM, QPSK, BPSK) IEEE 802.11n :OFDM(64QAM, 16QAM, QPSK, BPSK)
Antenna Type	:	Internal antenna, Maximum Gain is 1.56dBi for WLAN
Software version	:	V1.0
Hardware version/FVIN	:	V1.3

Remark: The worst-case simultaneous transmission configuration was evaluated with no non-compliance found. Results in this report are only for 2.4G Wi-Fi function, and there is no other transmitter involved.

2.2. Accessories of Device (EUT)

Accessories1 : USB-PD Chager
Manufacturer : Kuantech (Cambodia) Corpration Limited
Model : KSA-45P-45W D5
Input : AC 100-240V, 50/60Hz, 1.5A
Output : DC 5V/3A, DC 9V/3A, DC 12V/3A, DC 15V/3A,
DC 20V/2.25A, DC 3.3-16V/3A Max., 45W Max.

2.3. Tested Supporting System Details

No.	Description	Manufacturer	Model	Serial Number	Certification or DOC
1	Notebook	ACER	ZQT	N/A	DOC

2.4. Block Diagram of connection between EUT and simulators

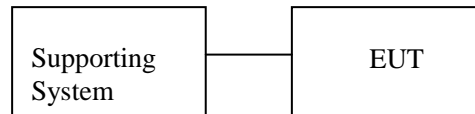

2.5. Test Mode Description

Duty cycle :100% Keeping TX			
Mode	data rate (Mbps)(see Note)	Channel	Frequency (MHz)
IEEE 802.11b	1	Low :CH1	2412
	1	Middle: CH6	2437
	1	High: CH11	2462
IEEE 802.11g	6	Low :CH1	2412
	6	Middle: CH6	2437
	6	High: CH11	2462
IEEE 802.11 n/HT20	6.5	Low :CH1	2412
	6.5	Middle: CH6	2437
	6.5	High: CH11	2462
IEEE 802.11 n/HT40	13.5	Low :CH3	2422
	13.5	Middle: CH6	2437
	13.5	High: CH9	2452

Note: According exploratory test, EUT will have maximum output power in those data rate. so those data rate were used for all test.

Channel list:					
For IEEE 802.11b, g, n/HT20, n/HT40					
Channel	Frequency (MHz)	Channel	Frequency (MHz)	Channel	Frequency (MHz)
CH1	2412	CH5	2432	CH9	2452
CH2	2417	CH6	2437	CH10	2457
CH3	2422	CH7	2442	CH11	2462
CH4	2427	CH8	2447		
For IEEE 802.11 n/HT40					
Channel	Frequency (MHz)	Channel	Frequency (MHz)	Channel	Frequency (MHz)
CH1	/	CH5	2432	CH9	2452
CH2	/	CH6	2437	CH10	/
CH3	2422	CH7	2442	CH11	/
CH4	2427	CH8	2447		

Setting output power (Max)		
802.11b	802.11g	802.11n(HT20/HT40)
16dBm	17dBm	17dBm

2.6. Test Conditions

Items	Required	Actual
Temperature range:	15-35°C	27°C
Humidity range:	25-75%	56%
Pressure range:	86-106kPa	98kPa

2.7. Test Facility

Shenzhen Alpha Product Testing Co., Ltd
Building i, No.2, Lixin Road, Fuyong Street, Bao'an District, 518103,
Shenzhen, Guangdong, China

June 21, 2018 File on Federal Communication Commission
Registration Number: 293961
Designation Number: CN1236

July 25, 2017 Certificated by IC
Registration Number: 12135A

2.8.Measurement Uncertainty

(95% confidence levels, k=2)

Item	Uncertainty
Uncertainty for Power point Conducted Emissions Test	2.74dB
Uncertainty for Radiation Emission test in 3m chamber (below 30MHz)	2.13 dB(Polarize: V)
	2.57dB(Polarize: H)
Uncertainty for Radiation Emission test in 3m chamber (30MHz to 1GHz)	3.77dB(Polarize: V)
	3.80dB(Polarize: H)
Uncertainty for Radiation Emission test in 3m chamber (1GHz to 25GHz)	4.16dB(Polarize: H)
	4.13dB(Polarize: V)
Uncertainty for radio frequency	5.4×10^{-8}
Uncertainty for conducted RF Power	0.37dB
Uncertainty for temperature	0.2°C
Uncertainty for humidity	1%
Uncertainty for DC and low frequency voltages	0.06%

2.9. Test Equipment List

Equipment	Manufacture	Model No.	Serial No.	Last cal.	Cal Interval
3m Semi-Anechoic	ETS-LINDGRE N	N/A	SEL0017	2018.09.21	1 Year
Spectrum analyzer	Agilent	E4407B	MY46185649	2018.09.21	1 Year
Receiver	R&S	ESCI	1166.5950K03-1011	2018.09.21	1 Year
Receiver	R&S	ESCI	101202	2018.09.21	1 Year
Bilog Antenna	Schwarzbeck	VULB 9168	VULB9168-438	2018.04.13	2 Year
Horn Antenna	EMCO	3115	640201028-06	2018.04.13	2 Year
Active Loop Antenna	Beijing Daze	ZN30900A	SEL0097	2018.04.13	2 Year
Cable	Resenberger	N/A	No.1	2018.09.21	1 Year
Cable	SCHWARZBEC K	N/A	No.2	2018.09.21	1 Year
Cable	SCHWARZBEC K	N/A	No.3	2018.09.21	1 Year
Pre-amplifier	Schwarzbeck	BBV9743	9743-019	2018.09.21	1 Year
Pre-amplifier	R&S	AFS33-18002650-30-8P-44	SEL0080	2018.09.21	1 Year
Temperature controller	Terchy	MHQ	120	2018.09.21	1 Year
L.I.S.N.#1	Schwarzbeck	NSLK8126	8126466	2018.09.21	1 Year
L.I.S.N.#2	ROHDE&SCHWARZ	ENV216	101043	2018.09.21	1 Year
20db Attenuator	ICPROBING	IATS1	82347	2018.09.21	1 Year
Horn Antenna	SCHWARZBEC K	BBHA 9170	BBHA 9170294	2018.04.13	2 Year
Power Meter	Agilent	E9300A	MY41496625	2018.09.21	1 Year
Temperature Chamber	Gongwen	GDS-250	080943	2018.09.11	1 Year
Switching Mode Power Supply	JUNKE	JK12010S	20140927-6	2018.09.11	1 Year

3. SPURIOUS EMISSION

3.1. Test Limits

All the emissions appearing within 15.205 restricted frequency bands shall not exceed the limits shown in 15.209, all the other emissions shall be at least 20dB below the fundamental emissions, or comply with 15.209 limits.

15.205 Restricted frequency band

MHz	MHz	MHz	GHz
0.090 - 0.110	16.42 - 16.423	399.9 - 410	4.5 - 5.15
¹ 0.495 - 0.505	16.69475 - 16.69525	608 - 614	5.35 - 5.46
2.1735 - 2.1905	16.80425 - 16.80475	960 - 1240	7.25 - 7.75
4.125 - 4.128	25.5 - 25.67	1300 - 1427	8.025 - 8.5
4.17725 - 4.17775	37.5 - 38.25	1435 - 1626.5	9.0 - 9.2
4.20725 - 4.20775	73 - 74.6	1645.5 - 1646.5	9.3 - 9.5
6.215 - 6.218	74.8 - 75.2	1660 - 1710	10.6 - 12.7
6.26775 - 6.26825	108 - 121.94	1718.8 - 1722.2	13.25 - 13.4
6.31175 - 6.31225	123 - 138	2200 - 2300	14.47 - 14.5
8.291 - 8.294	149.9 - 150.05	2310 - 2390	15.35 - 16.2
8.362 - 8.366	156.52475 - 156.52525	2483.5 - 2500	17.7 - 21.4
8.37625 - 8.38675	156.7 - 156.9	2690 - 2900	22.01 - 23.12
8.41425 - 8.41475	162.0125 - 167.17	3260 - 3267	23.6 - 24.0
12.29 - 12.293	167.72 - 173.2	3332 - 3339	31.2 - 31.8
12.51975 - 12.52025	240 - 285	3345.8 - 3358	36.43 - 36.5
12.57675 - 12.57725	322 - 335.4	3600 - 4400	(²)

RSS-GEN Restricted frequency band

Table 7 – Restricted frequency bands ^{Note 1}

MHz	MHz	GHz
0.090 - 0.110	149.9 - 150.05	9.0 - 9.2
0.495 - 0.505	156.52475 - 156.52525	9.3 - 9.5
2.1735 - 2.1905	156.7 - 156.9	10.6 - 12.7
3.020 - 3.026	162.0125 - 167.17	13.25 - 13.4
4.125 - 4.128	167.72 - 173.2	14.47 - 14.5
4.17725 - 4.17775	240 – 285	15.35 - 16.2

4.20725 - 4.20775	322 - 335.4	17.7 - 21.4
5.677 - 5.683	399.9 - 410	22.01 - 23.12
6.215 - 6.218	608 - 614	23.6 - 24.0
6.26775 - 6.26825	960 - 1427	31.2 - 31.8
6.31175 - 6.31225	1435 - 1626.5	36.43 - 36.5
8.291 - 8.294	1645.5 - 1646.5	Above 38.6
8.362 - 8.366	1660 - 1710	
8.37625 - 8.38675	1718.8 - 1722.2	
8.41425 - 8.41475	2200 - 2300	
12.29 - 12.293	2310 - 2390	
12.51975 - 12.52025	2483.5 - 2500	
12.57675 - 12.57725	2655 - 2900	
13.36 - 13.41	3260 - 3267	
16.42 - 16.423	3332 - 3339	
16.69475 - 16.69525	3345.8 - 3358	
16.80425 - 16.80475	3500 - 4400	
25.5 - 25.67	4500 - 5150	
37.5 - 38.25	5350 - 5460	
73 - 74.6	7250 - 7750	
74.8 - 75.2	8025 - 8500	
108 - 138		

Note 1: Certain frequency bands listed in table 7 and in bands above 38.6 GHz are designated for licence-exempt applications. These frequency bands and the requirements that apply to related devices are set out in the 200 and 300 series of RSSs.

15.209 Limit

FREQUENCY MHz	DISTANCE Meters	FIELD STRENGTHS LIMIT	
		$\mu\text{V}/\text{m}$	$\text{dB}(\mu\text{V})/\text{m}$
0.009-0.490	300	2400/F(KHz)	/
0.490-1.705	30	24000/F(KHz)	/
1.705-30	30	30	29.5
30 ~ 88	3	100	40.0
88 ~ 216	3	150	43.5
216 ~ 960	3	200	46.0
960 ~ 1000	3	500	54.0
Above 1000	3	74.0 dB(μV)/m (Peak) 54.0 dB(μV)/m (Average)	
Note 1: The peak limit is 20 dB higher than the average limit			
Note 2: Peak limit applies (AVG limit + 20 dB) as well as RSS-247 Section 5.5			

Harmonic emissions limits comply with below 54 dB $\mu\text{V}/\text{m}$ at 3m. Other emissions radiated outside of the specified frequency bands, except for harmonics, shall be attenuated by at least 50 dB below the level of the fundamental or comply with the radiated emissions limits specified in section 15.209(a) limit in the table below has to be followed.

Table 5 – General field strength limits at frequencies above 30 MHz

Frequency (MHz)	Field strength ($\mu\text{V}/\text{m}$ at 3 m)
30 – 88	100
88 – 216	150
216 – 960	200
Above 960	500

Table 6 – General field strength limits at frequencies below 30 MHz

Frequency	Magnetic field strength (H-Field) ($\mu\text{A}/\text{m}$)	Measurement distance (m)
9 - 490 kHz ^{Note 1}	6.37/F (F in kHz)	300
490 - 1705 kHz	63.7/F (F in kHz)	30
1.705 - 30 MHz	0.08	30

Note 1: The emission limits for the ranges 9-90 kHz and 110-490 kHz are based on measurements employing a linear average detector.

3.2. Test Procedure

The measuring distance of 3m shall be used for measurements at frequency up to 1GHz and above 1GHz. The EUT was placed on a rotating 0.8 m high above ground for below 1GHz and 1.5m high for above 1GHz testing, the table was rotated 360 degrees to determine the position of the highest radiation

The Test antenna shall vary between 1m and 4m, both Horizontal and Vertical antenna are set of make measurement.

The initial step in collecting radiated emission data is a spectrum analyzer Peak detector mode pre-scanning the measurement frequency range. Significant Peaks are then marked. and then Quasi Peak Detector mode premeasured

If Peak value comply with QP limit below 1GHz, the EUT deemed to comply with QP limit. But the Peak value and average value both need to comply with applicable limit above 1GHz.

For the actual test configuration, please see the test setup photo.

3.3. Test Setup

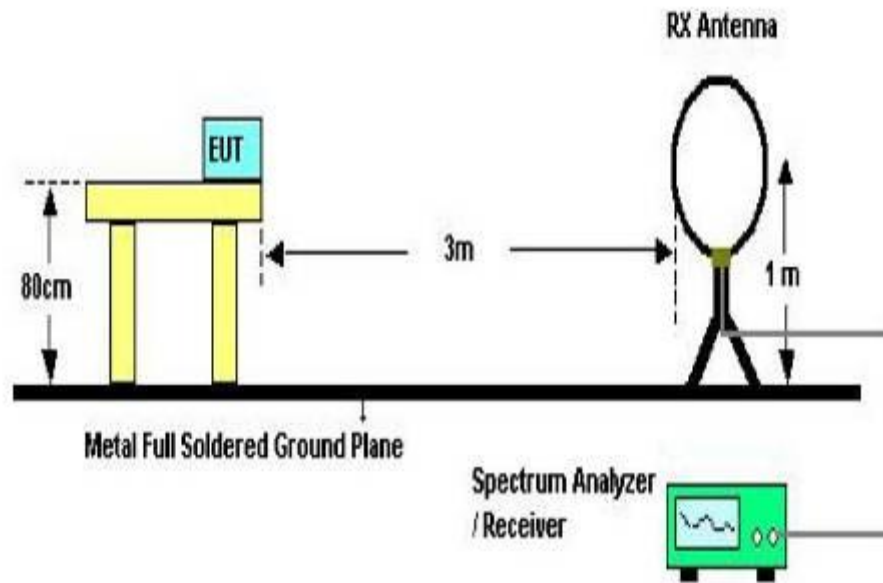

Below 30MHz Test Setup

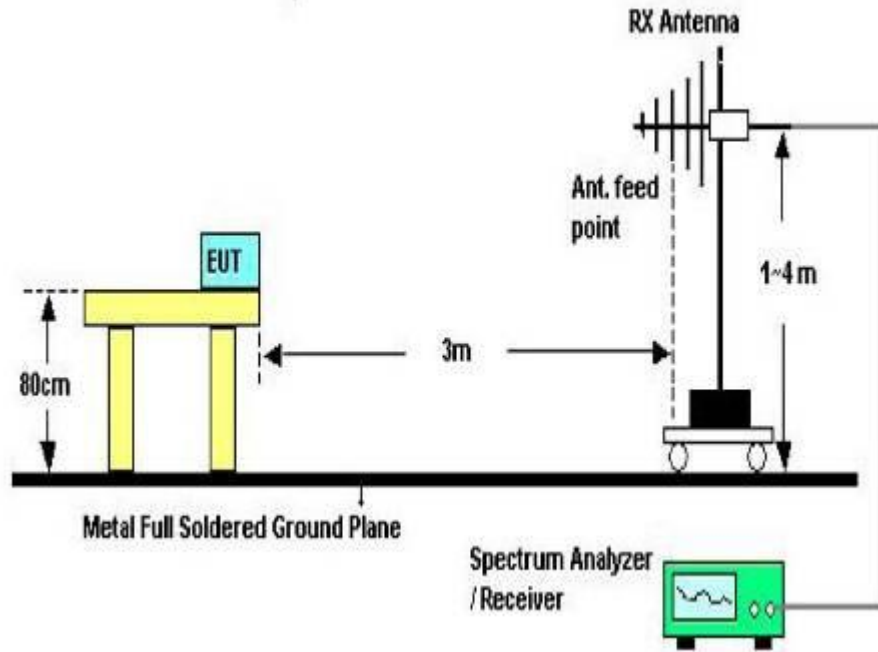

Above 30MHz Test Setup

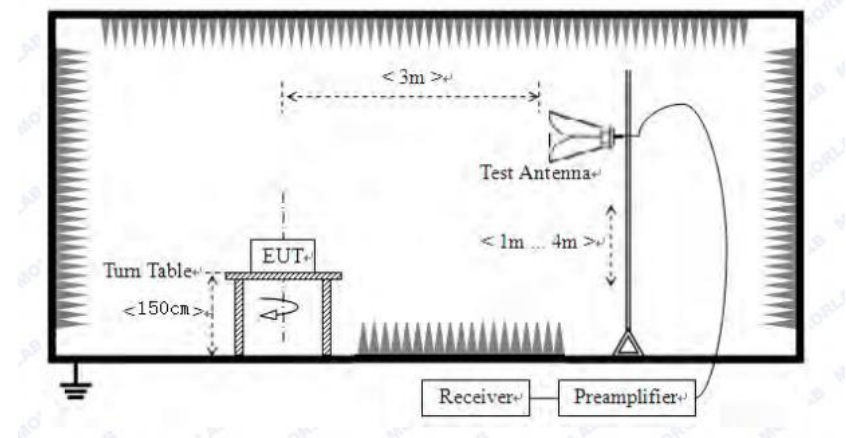

Above 1GHz Test Setup

3.4. Test Results

Test Condition

Continual Transmitting in maximum power.

9KHz~150KHz	RBW200Hz	VBW1KHz
150KHz~30MHz	RBW9KHz	VBW 30KHz
30MHz~1GHz	RBW120KHz	VBW 300KHz
Above1GHz	RBW1MHz	VBW 3MHz

We have scanned the EUT from 9kHz up to the 10th harmonic of the fundamental.

Detailed information please see the following page.

From 9KHz to 30MHz: Conclusion: PASS

Note:1.The amplitude of spurious emissions which are attenuated by more than 20dB below the permissible value has no need to be reported.

2.Only show the test data of the worst Channel in this report.

Test result for 802.11n/HT40 (High Channel), AC 120V/ 60Hz
Vertical

Radiated Emission Measurement

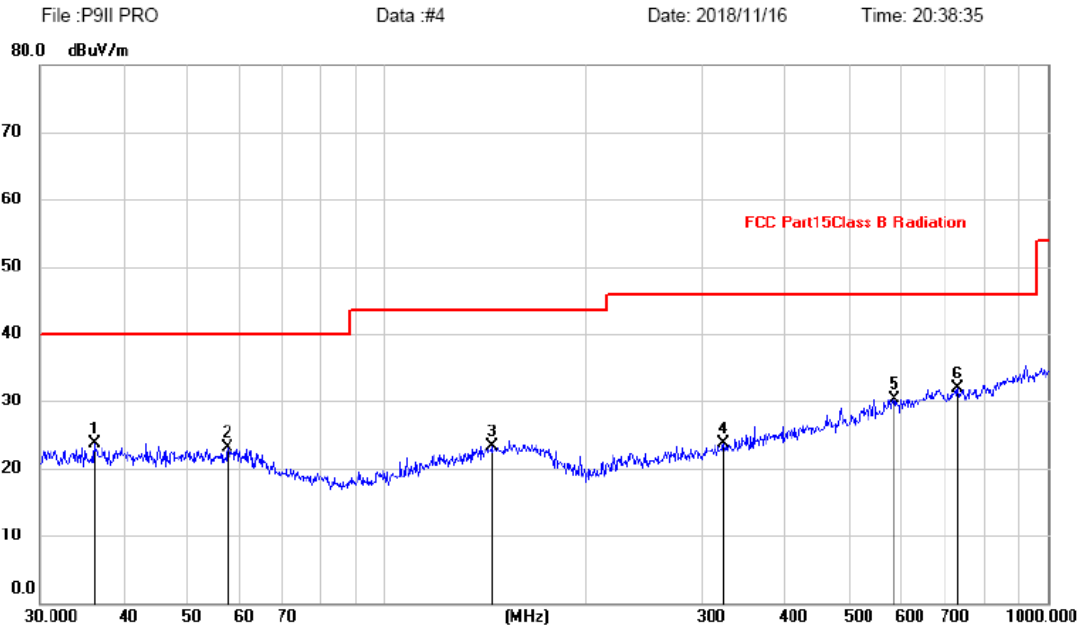

No.	Mk.	Freq. MHz	Reading Level dBuV	Correct Factor dB	Measure- ment dBuV/m	Limit dBuV/m	Margin dB	Detector	Antenna Height m	Table Degree
1		36.2541	10.20	13.59	23.79	40.00	-16.21	peak	1-4	0-360
2		57.5939	10.07	13.10	23.17	40.00	-16.83	peak	1-4	0-360
3		144.8417	9.14	14.17	23.31	43.50	-20.19	peak	1-4	0-360
4		324.4560	9.67	14.05	23.72	46.00	-22.28	peak	1-4	0-360
5		586.8436	11.29	18.96	30.25	46.00	-15.75	peak	1-4	0-360
6	*	731.9202	10.57	21.37	31.94	46.00	-14.06	peak	1-4	0-360

Note: 1. *:Maximum data; x:Over limit; !:over margin.

2. Measurement=Reading Level+Correct Factor; Correct Factor=Antenna Factor+Cable Loss.

Horizontal

Radiated Emission Measurement

File :P9II PRO

Data :#3

Date: 2018/11/16

Time: 20:37:16

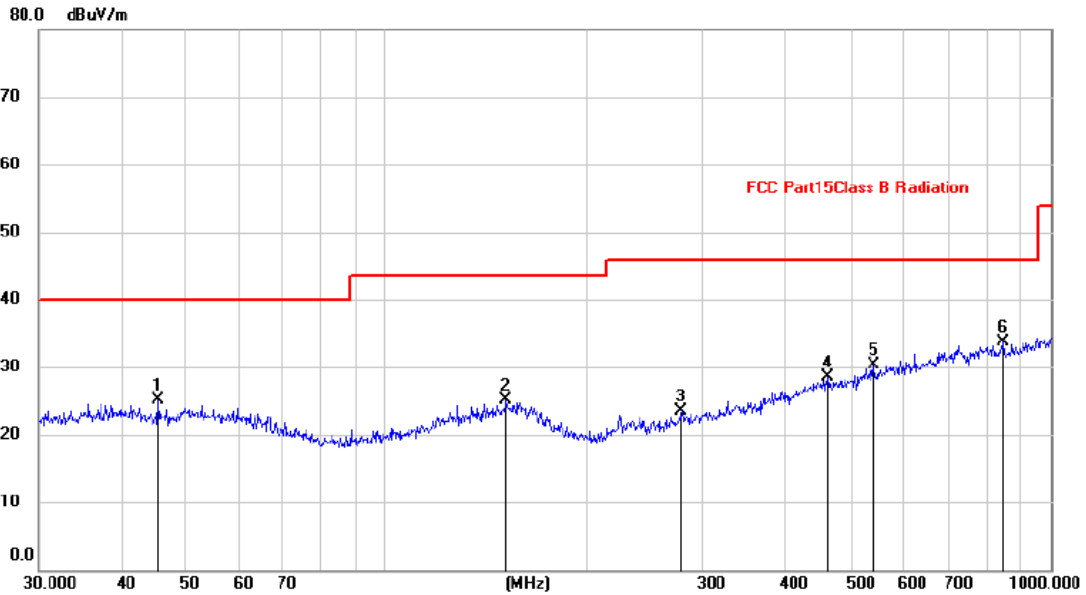

No.	Mk.	Freq. MHz	Reading Level dBuV	Correct Factor dB	Measure- ment dBuV/m	Limit dBuV/m	Margin dB	Antenna Height m	Table Degree
1		45.3755	11.50	13.69	25.19	40.00	-14.81	peak	1-4 0-360
2		151.0665	10.54	14.56	25.10	43.50	-18.40	peak	1-4 0-360
3		278.0668	10.51	12.94	23.45	46.00	-22.55	peak	1-4 0-360
4		460.7271	11.40	17.12	28.52	46.00	-17.48	peak	1-4 0-360
5		539.4775	12.08	18.22	30.30	46.00	-15.70	peak	1-4 0-360
6	*	848.0563	10.97	22.68	33.65	46.00	-12.35	peak	1-4 0-360

Note:1. *:Maximum data; x:Over limit; !:over margin.

2.Measurement=Reading Level+Correct Factor; Correct Factor=Antenna Factor+Cable Loss.

From 1G-25GHz

Test Mode: IEEE 802.11b TX Low									
Freq (MHz)	Read Level (dBUV/m)	Polar (H/V)	Antenna Factor (dB/m)	Cable loss(dB)	Amp Factor (dB)	Result (dBUV/m)	Limit (dBUV/m)	Margin (dB)	Remark
4824	47.10	V	33.95	10.18	34.26	56.97	74	-17.03	PK
4824	36.48	V	33.95	10.18	34.26	46.35	54	-7.65	AV
7236	/	/	/	/	/	/	/	/	/
9648	/	/	/	/	/	/	/	/	/
4824	49.87	H	33.95	10.18	34.26	59.74	74	-14.26	PK
4824	38.63	H	33.95	10.18	34.26	48.50	54	-5.50	AV
7236	/	/	/	/	/	/	/	/	/
9648	/	/	/	/	/	/	/	/	/
Test Mode: IEEE 802.11b TX Mid									
4874	46.58	V	33.93	10.2	34.29	56.42	74	-17.58	PK
4874	34.97	V	33.93	10.2	34.29	44.81	54	-9.19	AV
7311	/	/	/	/	/	/	/	/	/
9748	/	/	/	/	/	/	/	/	/
4874	47.68	H	33.93	10.2	34.29	57.52	74	-16.48	PK
4874	36.34	H	33.93	10.2	34.29	46.18	54	-7.82	AV
7311	/	/	/	/	/	/	/	/	/
9748	/	/	/	/	/	/	/	/	/
Test Mode: IEEE 802.11b TX High									
4924	47.13	V	33.98	10.22	34.25	57.08	74	-16.92	PK
4924	35.85	V	33.98	10.22	34.25	45.80	54	-8.20	AV
7386	/	/	/	/	/	/	/	/	/
9848	/	/	/	/	/	/	/	/	/
4924	50.09	H	33.98	10.22	34.25	60.04	74	-13.96	PK
4924	38.94	H	33.98	10.22	34.25	48.89	54	-5.11	AV
7386	/	/	/	/	/	/	/	/	/
9848	/	/	/	/	/	/	/	/	/
Note:									
1, Result = Read level + Antenna factor + cable loss-Amp factor									
2, All the other emissions not reported were too low to read and deemed to comply with FCC limit.									

Test Mode: IEEE 802.11g TX Low									
Freq (MHz)	Read Level (dBuV/m)	Polar (H/V)	Antenna Factor (dB/m)	Cable loss(dB)	Amp Factor (dB)	Result (dBuV/m)	Limit (dBuV/m)	Margin (dB)	Remark
4824	46.81	V	33.95	10.18	34.26	56.68	74	-17.32	PK
4824	36.47	V	33.95	10.18	34.26	46.34	54	-7.66	AV
7236	/	/	/	/	/	/	/	/	/
9648	/	/	/	/	/	/	/	/	/
4824	49.75	H	33.95	10.18	34.26	59.62	74	-14.38	PK
4824	38.23	H	33.95	10.18	34.26	48.10	54	-5.90	AV
7236	/	/	/	/	/	/	/	/	/
9648	/	/	/	/	/	/	/	/	/
Test Mode: IEEE 802.11g TX Mid									
4874	46.79	V	33.93	10.2	34.29	56.63	74	-17.37	PK
4874	34.88	V	33.93	10.2	34.29	44.72	54	-9.28	AV
7311	/	/	/	/	/	/	/	/	/
9748	/	/	/	/	/	/	/	/	/
4874	47.66	H	33.93	10.2	34.29	57.50	74	-16.50	PK
4874	36.90	H	33.93	10.2	34.29	46.74	54	-7.26	AV
7311	/	/	/	/	/	/	/	/	/
9748	/	/	/	/	/	/	/	/	/
Test Mode: IEEE 802.11g TX High									
4924	47.54	V	33.98	10.22	34.25	57.49	74	-16.51	PK
4924	36.19	V	33.98	10.22	34.25	46.14	54	-7.86	AV
7386	/	/	/	/	/	/	/	/	/
9848	/	/	/	/	/	/	/	/	/
4924	50.30	H	33.98	10.22	34.25	60.25	74	-13.75	PK
4924	39.11	H	33.98	10.22	34.25	49.06	54	-4.94	AV
7386	/	/	/	/	/	/	/	/	/
9848	/	/	/	/	/	/	/	/	/
Note:									
1, Result = Read level + Antenna factor + cable loss-Amp factor									
2, All the other emissions not reported were too low to read and deemed to comply with FCC limit.									

Test Mode: IEEE 802.11n HT20 TX Low									
Freq (MHz)	Read Level (dBuV/m)	Polar (H/V)	Antenna Factor (dB/m)	Cable loss (dB)	Amp Factor (dB)	Result (dBuV/m)	Limit (dBuV/m)	Margin (dB)	Remark
4824	46.85	V	33.95	10.18	34.26	56.72	74	-17.28	PK
4824	34.43	V	33.95	10.18	34.26	44.30	54	-9.70	AV
7236	/	/	/	/	/	/	/	/	/
9648	/	/	/	/	/	/	/	/	/
4824	47.76	H	33.95	10.18	34.26	57.63	74	-16.37	PK
4824	36.67	H	33.95	10.18	34.26	46.54	54	-7.46	AV
7236	/	/	/	/	/	/	/	/	/
9648	/	/	/	/	/	/	/	/	/
Test Mode: IEEE 802.11n HT20 TX Mid									
4874	47.38	V	33.93	10.2	34.25	57.26	74	-16.74	PK
4874	36.34	V	33.93	10.2	34.25	46.22	54	-7.78	AV
7311	/	/	/	/	/	/	/	/	/
9748	/	/	/	/	/	/	/	/	/
4874	49.92	H	33.93	10.2	34.29	59.76	74	-14.24	PK
4874	38.44	H	33.93	10.2	34.29	48.28	54	-5.72	AV
7311	/	/	/	/	/	/	/	/	/
9748	/	/	/	/	/	/	/	/	/
Test Mode: IEEE 802.11n HT20 TX High									
4924	46.86	V	33.98	10.22	34.25	56.81	74	-17.19	PK
4924	34.53	V	33.98	10.22	34.25	44.48	54	-9.52	AV
7386	/	/	/	/	/	/	/	/	/
9848	/	/	/	/	/	/	/	/	/
4924	47.55	H	33.98	10.22	34.25	57.50	74	-16.50	PK
4924	36.96	H	33.98	10.22	34.25	46.91	54	-7.09	AV
7386	/	/	/	/	/	/	/	/	/
9848	/	/	/	/	/	/	/	/	/
Note:									
1, Result = Read level + Antenna factor + cable loss - Amp factor									
2, All the other emissions not reported were too low to read and deemed to comply with FCC limit.									

Test Mode IEEE 802.11n HT40 TX Low									
Freq (MHz)	Read Level (dBuV/m)	Polar (H/V)	Antenna Factor (dB/m)	Cable loss(dB)	Amp Factor (dB)	Result (dBuV/m)	Limit (dBuV/m)	Margin (dB)	Remark
4844	47.57	V	33.95	10.18	34.26	57.44	74	-16.56	PK
4844	35.90	V	33.95	10.18	34.26	45.77	54	-8.23	AV
7266	/	/	/	/	/	/	/	/	/
9688	/	/	/	/	/	/	/	/	/
4844	50.16	H	33.95	10.18	34.26	60.03	74	-13.97	PK
4844	38.80	H	33.95	10.18	34.26	48.67	54	-5.33	AV
7266	/	/	/	/	/	/	/	/	/
9688	/	/	/	/	/	/	/	/	/
Test Mode: IEEE 802.11n HT40 TX Mid									
4874	46.29	V	33.93	10.2	34.29	56.13	74	-17.87	PK
4874	34.84	V	33.93	10.2	34.29	44.68	54	-9.32	AV
7311	/	/	/	/	/	/	/	/	/
9748	/	/	/	/	/	/	/	/	/
4874	48.29	H	33.93	10.2	34.29	58.13	74	-15.87	PK
4874	36.74	H	33.93	10.2	34.29	46.58	54	-7.42	AV
7311	/	/	/	/	/	/	/	/	/
9748	/	/	/	/	/	/	/	/	/
Test Mode: IEEE 802.11n HT40 TX High									
4904	47.16	V	33.98	10.22	34.25	57.11	74	-16.89	PK
4904	35.72	V	33.98	10.22	34.25	45.67	54	-8.33	AV
7356	/	/	/	/	/	/	/	/	/
9808	/	/	/	/	/	/	/	/	/
4904	50.16	H	33.98	10.22	34.25	60.11	74	-13.89	PK
4904	39.17	H	33.98	10.22	34.25	49.12	54	-4.88	AV
7356	/	/	/	/	/	/	/	/	/
9808	/	/	/	/	/	/	/	/	/
Note:									
1, Result = Read level + Antenna factor + cable loss - Amp factor									
2, All the other emissions not reported were too low to read and deemed to comply with FCC limit.									

4. POWER LINE CONDUCTED EMISSION

4.1. Test Limits

Frequency MHz	Limits dB(μ V)	
	Quasi-peak Level	Average Level
0.15 -0.50	66 -56*	56 - 46*
0.50 -5.00	56	46
5.00 -30.00	60	50

- Notes: 1. *Decreasing linearly with logarithm of frequency.
 2. The lower limit shall apply at the transition frequencies.
 3. The limit decreases in line with the logarithm of the frequency in the rang of 0.15 to 0.50 MHz.

4.2. Test Procedure

The EUT is put on the plane 0.8m high above the ground by insulating support and is connected to the power mains through a line impedance stabilization network (L.I.S.N.). This provides a 50ohm coupling impedance for the EUT system. Please refer the block diagram of the test setup and photographs. Both sides of AC lines are checked to find out the maximum conducted emission. In order to find the maximum emission levels, the relative positions of equipment and all of the interface cables shall be changed according to ANSI C63.10:2013 on Conducted Emission Measurement.

The bandwidth of test receiver is set at 9 kHz.

4.3. Test Setup

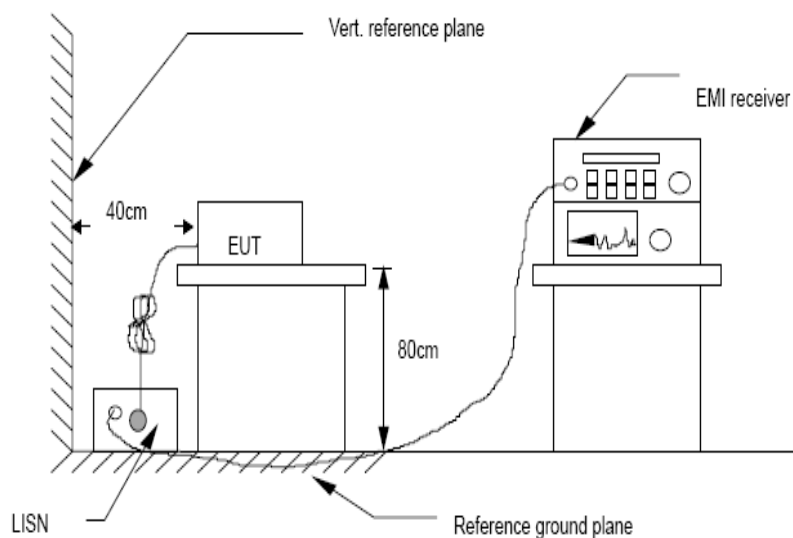

4.4. Test Results

Test result for 802.11n/HT40 (High Channel), AC 120V/ 60Hz

Line:

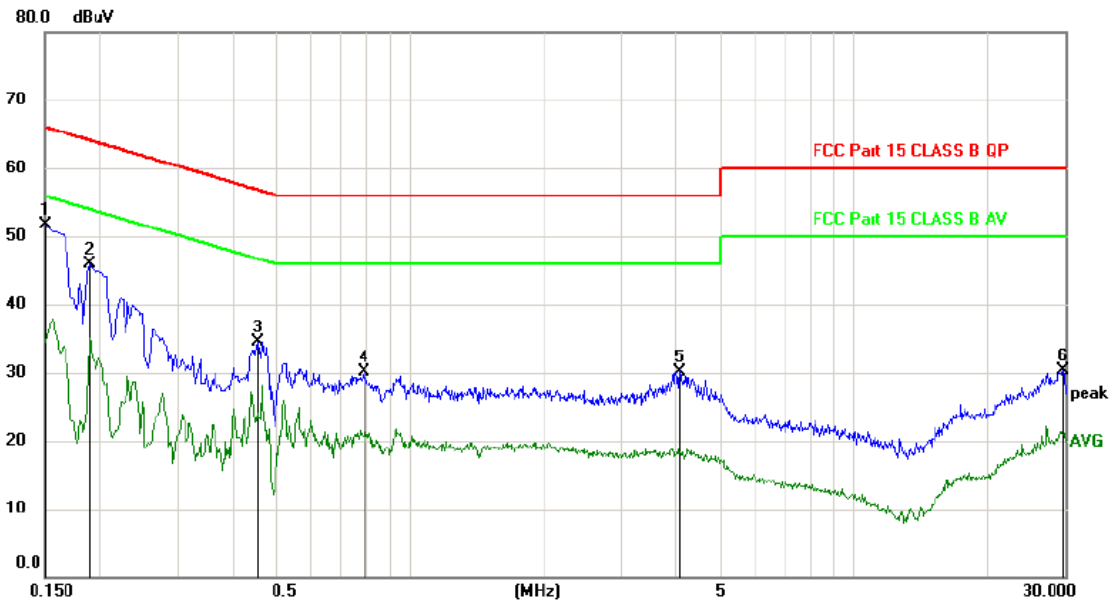

No.	Mk.	Freq. MHz	Reading Level dBuV	Correct Factor dB	Measure- ment dBuV	Limit dBuV	Margin dB	Detector	Comment
1	*	0.1500	51.62	0.13	51.75	66.00	-14.25	peak	
2		0.1890	45.84	0.13	45.97	64.08	-18.11	peak	
3		0.4560	34.44	0.13	34.57	56.77	-22.20	peak	
4		0.7860	30.06	0.13	30.19	56.00	-25.81	peak	
5		4.0590	30.00	0.20	30.20	56.00	-25.80	peak	
6		29.7779	29.11	1.17	30.28	60.00	-29.72	peak	

*:Maximum data x:Over limit !:over margin

Note: Measurement=Reading Level+Correc Factor. Factor=(LISN or ISN or PLC or Current Probe)Factor+Cable

Neutral:

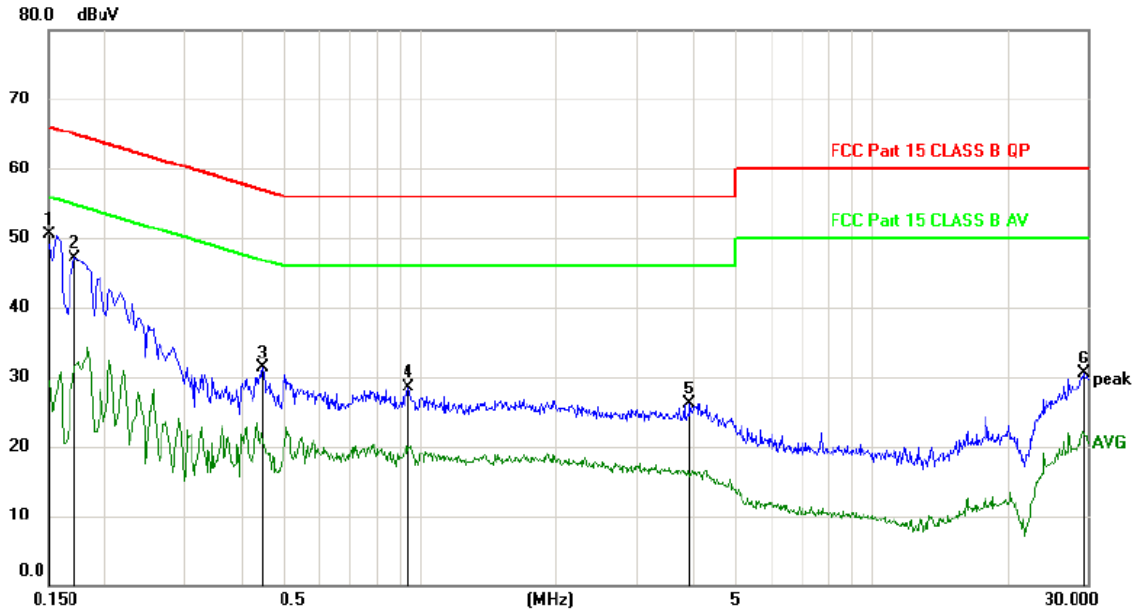

No.	Mk.	Freq. MHz	Reading Level dBuV	Correct Factor dB	Measure- ment dBuV	Limit dBuV	Margin dB	Detector	Comment
1	*	0.1500	50.36	0.13	50.49	66.00	-15.51	peak	
2		0.1710	47.07	0.13	47.20	64.91	-17.71	peak	
3		0.4470	31.16	0.13	31.29	56.93	-25.64	peak	
4		0.9420	28.31	0.14	28.45	56.00	-27.55	peak	
5		3.9630	25.91	0.20	26.11	56.00	-29.89	peak	
6		29.4660	29.33	1.14	30.47	60.00	-29.53	peak	

*:Maximum data x:Over limit !:over margin

Note: Measurement=Reading Level+Correc Factor. Factor=(LISN or ISN or PLC or Current Probe)Factor+Cable

5. CONDUCTED MAXIMUM OUTPUT POWER

5.1. Test limits

Please refer RSS-247 & FCC PART 15: 15.247.

Regulation 15.247(b) The limit of Maximum Peak Output Power Measurement is 1 W(30dBm)

5.2. Test Procedure

Details see the KDB558074 D01 Meas Guidance V05

5.2.1 Place the EUT on the table and set it in transmitting mode.

5.2.2 Connected the EUT's antenna port to peak power meter by 20dB attenuator.

5.2.3 Measure out each mode and each bands peak output power of EUT.

Note: The cable loss and attenuator loss were offset into measure device as amplitude offset.

5.3. Test Setup

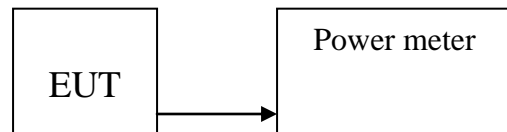

5.4. Test Results

PASS

Detailed information please see the following page.

Mode	Frequency (MHz)	PK Output power(dBm)	Limit (dBm)	Result
IEEE 802.11 b	CH1: 2412	14.30	30	PASS
	CH6: 2437	13.76	30	PASS
	CH11: 2462	14.59	30	PASS
IEEE 802.11 g	CH1: 2412	15.68	30	PASS
	CH6: 2437	15.16	30	PASS
	CH11: 2462	14.81	30	PASS
IEEE 802.11 n/HT20	CH1: 2412	13.05	30	PASS
	CH6: 2437	13.29	30	PASS
	CH11: 2462	12.57	30	PASS
IEEE 802.11 n/HT40	CH3: 2422	13.63	30	PASS
	CH6: 2437	13.70	30	PASS
	CH9: 2452	13.46	30	PASS

6. PEAK POWER SPECTRAL DENSITY

6.1. Test limits

6.1.1 Please refer RSS-247 & FCC PART 15: 15.247.

6.1.2 For direct sequence systems, the peak power spectral density conducted from the intentional radiator to the antenna shall not be greater than 8dBm in any 3kHz band during any time interval of continuous transmission.

6.1.3 The direct sequence operating of the hybrid system, with the frequency hopping operation turned off, shall comply with the power density requirements of paragraph (d) of this section.

6.2. Test Procedure

Details see the KDB558074 D01 Meas Guidance V05

6.2.1 Place the EUT on the table and set it in transmitting mode.

6.2.2 Remove the antenna from the EUT and then connect a low loss RF cable from the antenna port to the spectrum analyzer.

6.2.3 Set the spectrum analyzer as $RBW = 3\text{kHz}$ (Set the RBW to: $3\text{ kHz} \leq RBW \leq 100\text{ kHz}$), $VBW = 10\text{kHz}$ (Set the $VBW \geq 3 \times RBW$), $\text{span} \geq 1.5 \times \text{DTS bandwidth}$., detail see the test plot.

6.2.4 Record the max reading.

6.2.5 Repeat the above procedure until the measurements for all frequencies are completed.

6.3. Test Setup

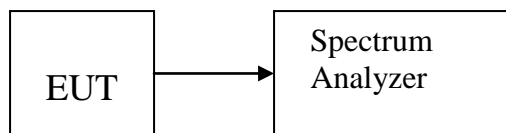

6.4. Test Results

Test CH	Power Spectral Density (dBm/3kHz)				Limit (dBm/3kHz)	Result
	802.11b	802.11g	802.11n(HT20)	802.11n(HT40)		
Lowest	-17.748	-20.522	-21.011	-23.633	8.00	Pass
Middle	-18.133	-20.786	-21.285	-24.331		
Highest	-19.530	-22.630	-22.753	-24.865		

802.11b 802.11g

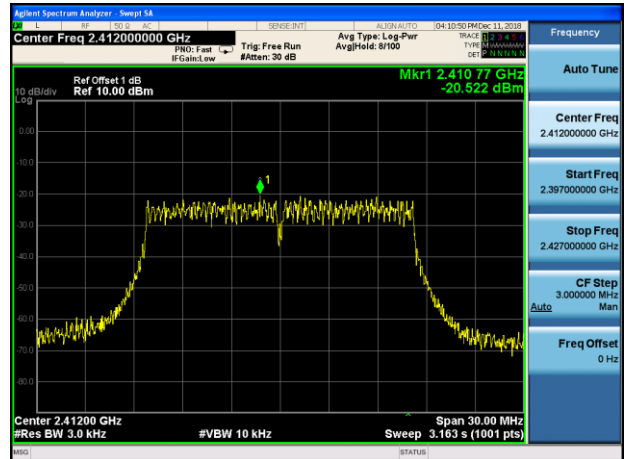
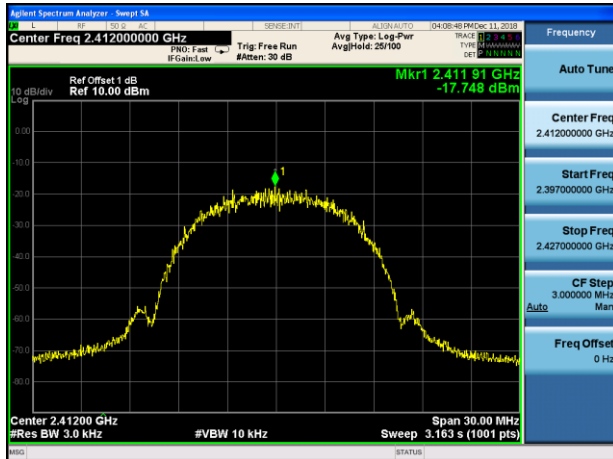

Lowest channel

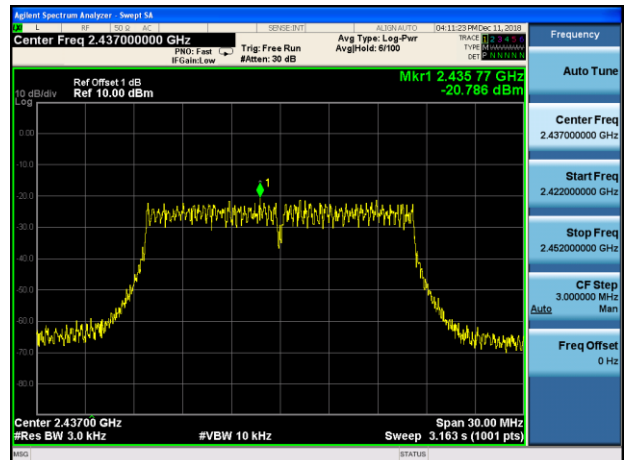
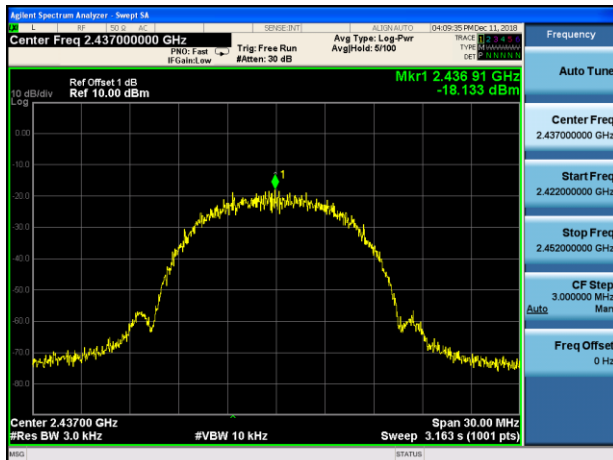

Middle channel

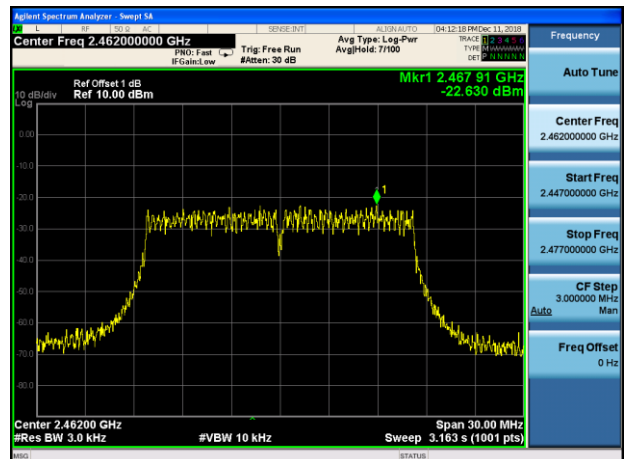
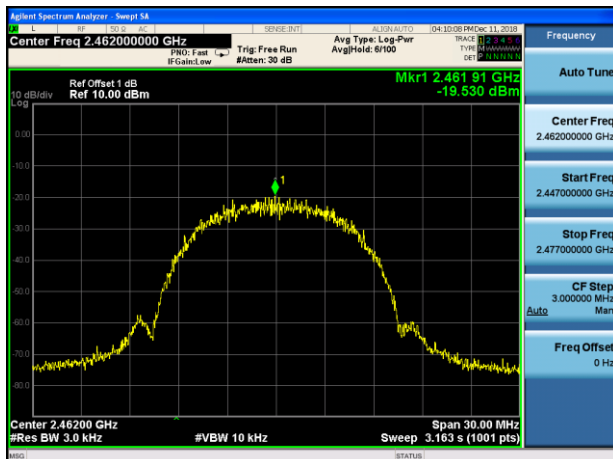

Highest channel

802.11n(HT20)

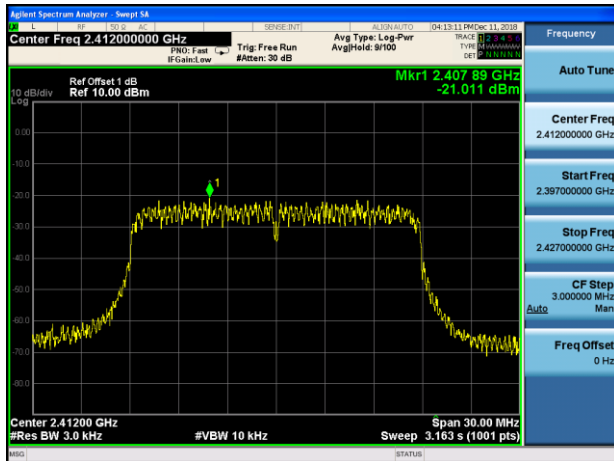

Lowest channel

802.11n(HT40)

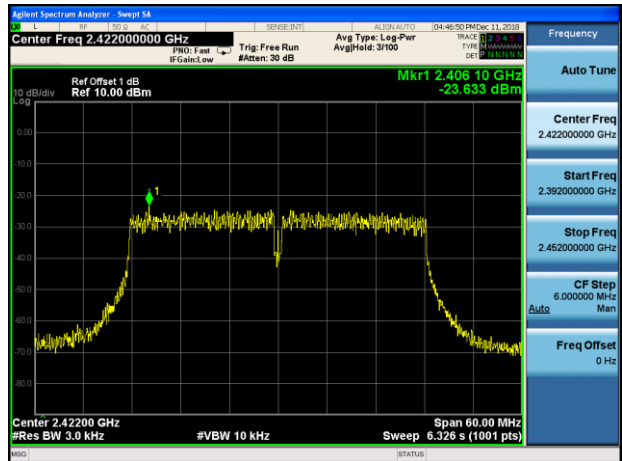

Lowest channel

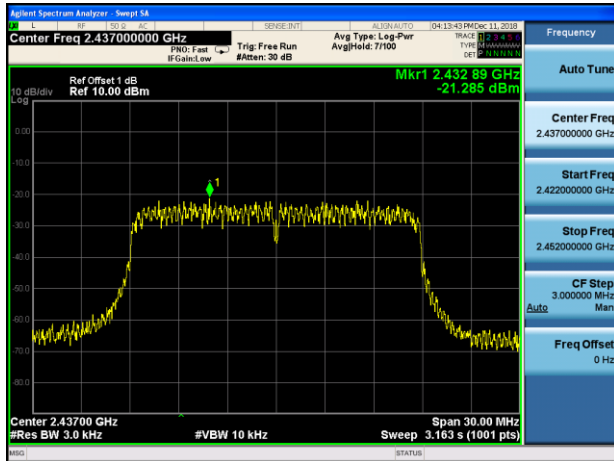

Middle channel

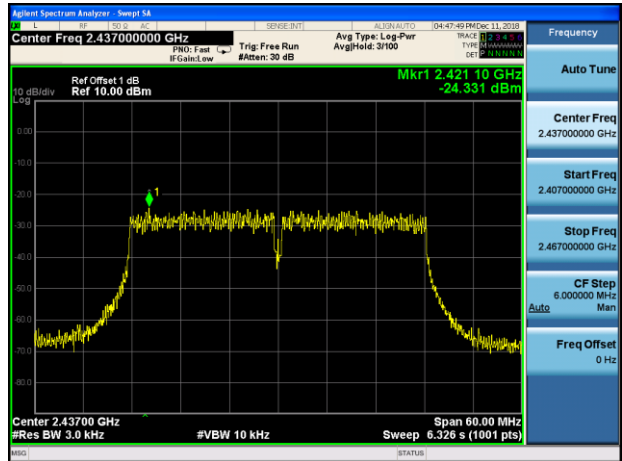

Middle channel

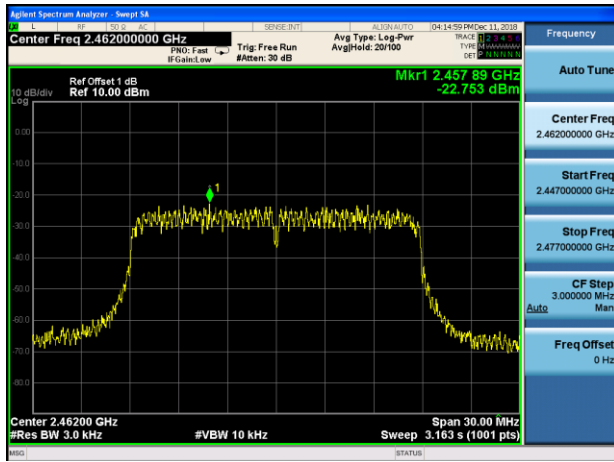

Highest channel

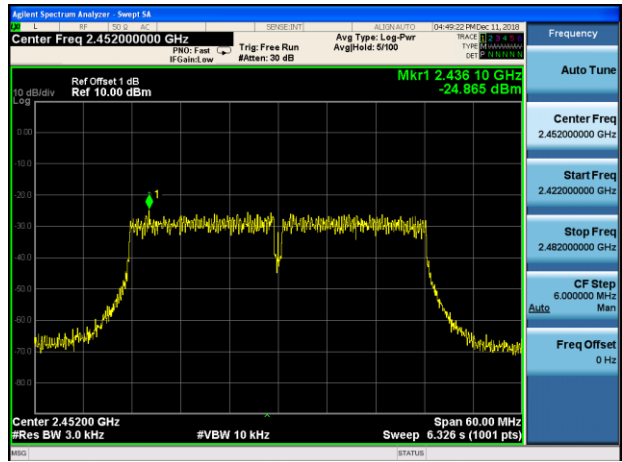

Highest channel

7. BANDWIDTH

7.1. Test limits

Please refer RSS-247 & FCC PART 15: 15.247

For direct sequence systems, the minimum 6dB bandwidth shall be at least 500 kHz.

7.2. Test Procedure

Details see the KDB558074 D01 Meas Guidance V05

- a) The bandwidth is measured at an amplitude level reduced 6dB from the reference level. The reference level is the level of the highest amplitude signal observed from the transmitter at the fundamental frequency. Once the reference level is established, the equipment is conditioned with typical modulating signal to produce the worst-case (i.e. the widest) bandwidth.
- b) The test receiver set $RBW = 100\text{kHz}$, $VBW \geq 3 * RBW = 300\text{kHz}$, Peak Detector, Sweep time set auto, detail see the test plot.

7.3. Test Setup

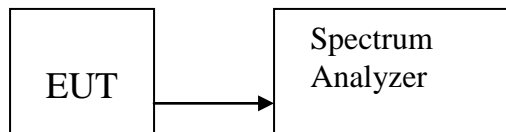

7.4. Test Results

IEEE 802.11b:					
Channel	Frequency (MHz)	6dB Bandwidth (MHz)	99% Occupied Bandwidth (MHz)	Limit (MHz)	Result
Low	2412	7.605	12.168	0.5	PASS
Mid	2437	7.594	12.081	0.5	PASS
High	2462	7.150	12.071	0.5	PASS
IEEE 802.11g					
Channel	Frequency (MHz)	6dB Bandwidth (MHz)	99% Occupied Bandwidth (MHz)	Limit (MHz)	Result
Low	2412	16.39	16.520	0.5	PASS
Mid	2437	16.36	16.507	0.5	PASS
High	2462	16.44	16.548	0.5	PASS
IEEE 802.11n/HT20					
Channel	Frequency (MHz)	6dB Bandwidth (MHz)	99% Occupied Bandwidth (MHz)	Limit (MHz)	Result
Low	2412	17.63	17.691	0.5	PASS
Mid	2437	17.23	17.649	0.5	PASS
High	2462	17.62	17.709	0.5	PASS
IEEE 802.11n/HT40					
Channel	Frequency (MHz)	6dB Bandwidth (MHz)	99% Occupied Bandwidth (MHz)	Limit (MHz)	Result
Low	2422	35.38	35.989	0.5	PASS
Mid	2437	35.10	35.727	0.5	PASS
High	2452	35.57	36.056	0.5	PASS

IEEE 802.11b:

IEEE 802.11g:

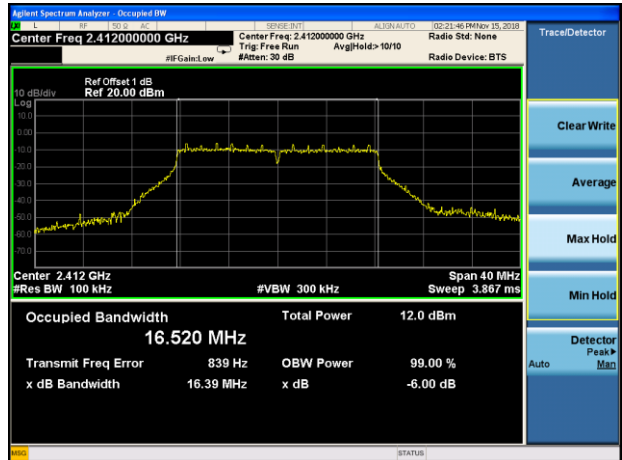
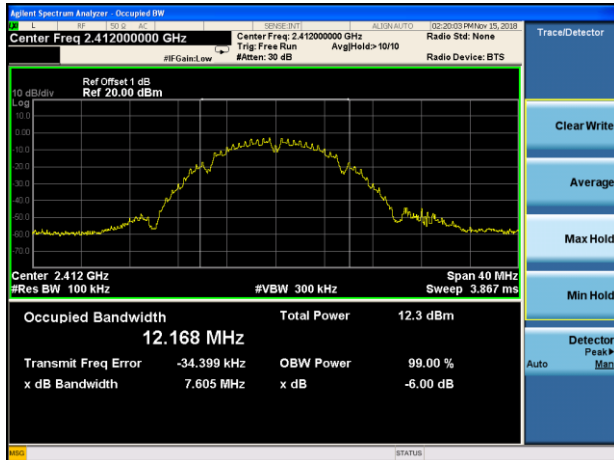

Lowest channel

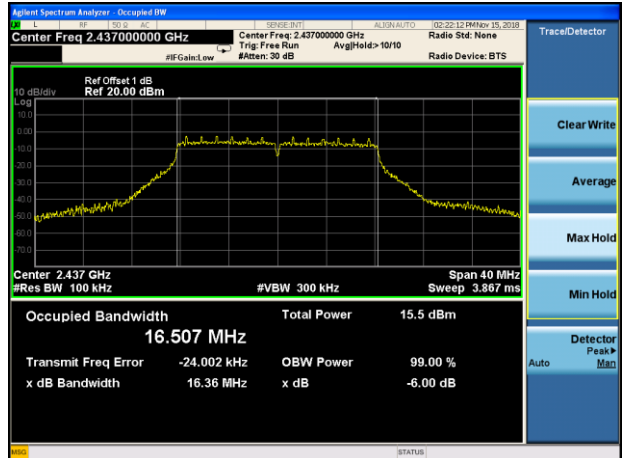
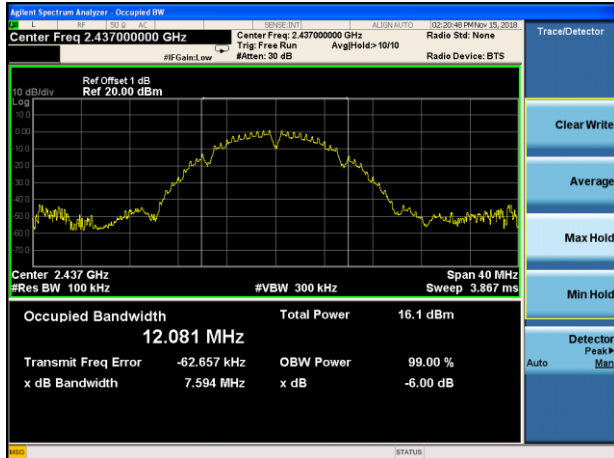

Middle channel

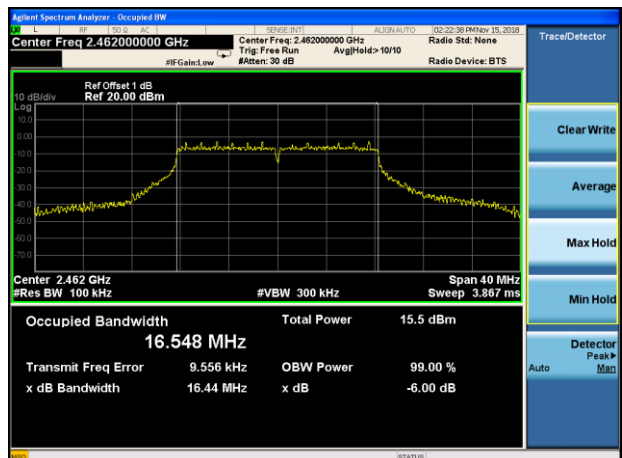
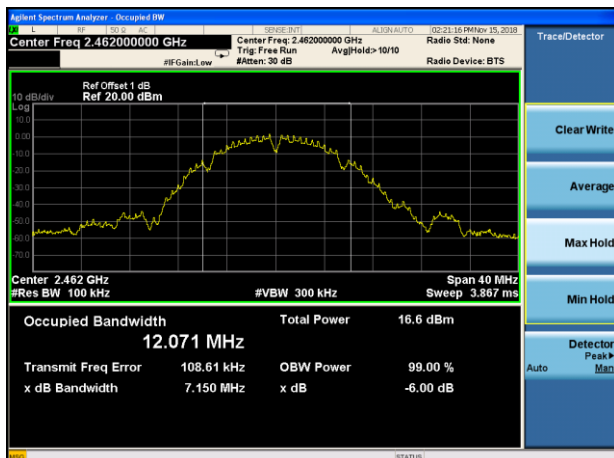

Highest channel

IEEE 802.11n/HT20

IEEE 802.11n/HT40

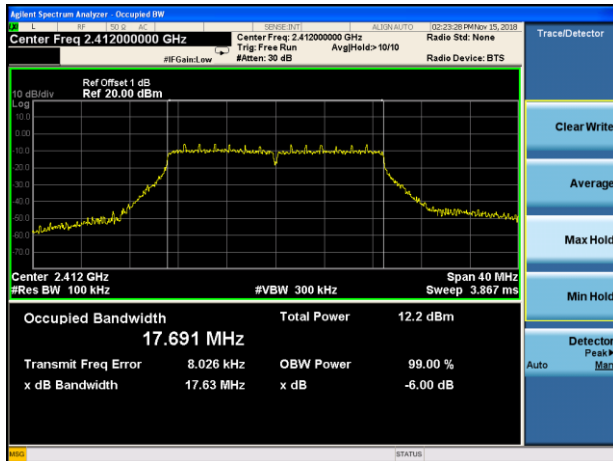

Lowest channel

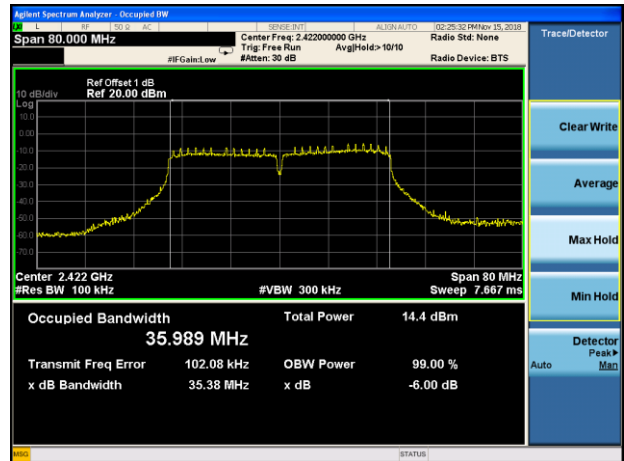

Lowest channel

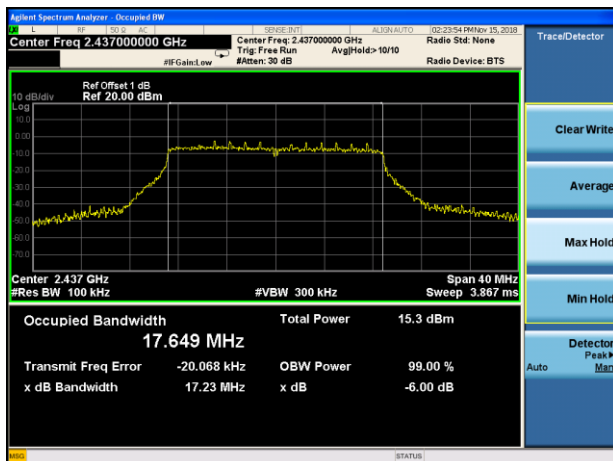

Middle channel

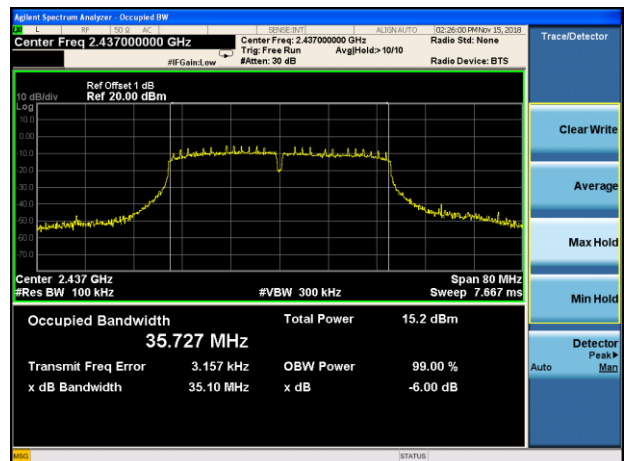

Middle channel

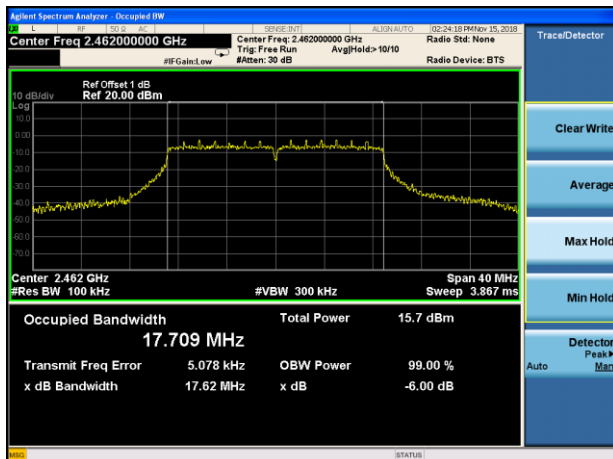

Highest channel

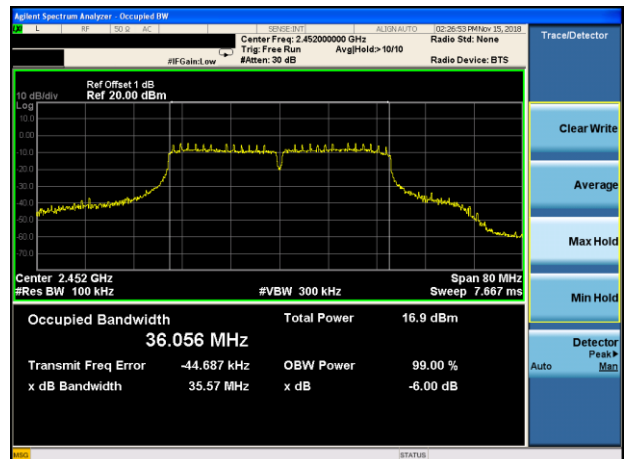

Highest channel

8. BAND EDGE CHECK

8.1. Test limits

Please refer RSS-GEN & FCC PART 15: 15.247

All the lower and upper band-edges emissions appearing within 2310MHz to 2390MHz and 2483.5MHz to 2500MHz restricted frequency bands shall not exceed the limits shown in 15.209, all the other emissions outside operation frequency band 2400MHz to 2483.5MHz shall be at least 20dB below the fundamental emissions, or comply with 15.209 limits and RSS-GEN limits.

8.2. Test Procedure

Details see the KDB558074 D01 Meas Guidance V05

8.2.1 Put the EUT on a 1.5m high table, power on the EUT. Emissions were scanned and measured rotating the EUT to 360 degrees, Find the maximum Emission

8.2.2 Check the spurious emissions out of band.

8.2.3 RBW 1MHz, VBW 3MHz, peak detector for peak value , RBW 1MHz ,VBW 10Hz , RMS detector for AV value.

8.3. Test Setup

Same as 5.2.2.

8.4. Test Results

PASS.

Detailed information please see the following page.

Test Mode: IEEE 802.11b-Low
Polarization: Vertical

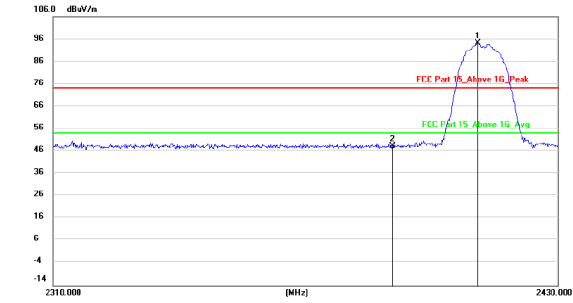

No.	Mk.	Freq.	Reading Level	Correct Factor	Measurement	Limit	Margin	Antenna Height	Table Degree	Comment
		MHz	dBuV	dB	dBuV/m	dBuV/m	dB	cm	degree	
1	*	2410.595	97.46	-3.40	94.06	74.00	20.06			peak
2		2390.000	51.70	-3.40	48.30	74.00	-25.70			peak

Polarization: Horizontal

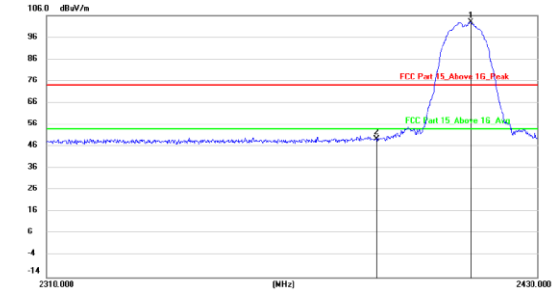

No.	Mk.	Freq.	Reading Level	Correct Factor	Measurement	Limit	Margin	Antenna Height	Table Degree	Comment
		MHz	dBuV	dB	dBuV/m	dBuV/m	dB	cm	degree	
1	*	2413.410	106.13	-3.41	102.72	74.00	28.72			peak
2		2390.000	52.95	-3.40	49.55	74.00	-24.45			peak

Test Mode: IEEE 802.11b-High
Polarization: Vertical

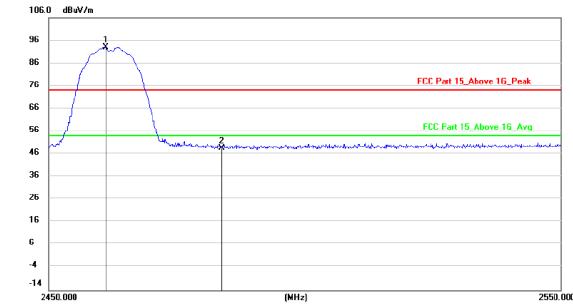

No.	Mk.	Freq.	Reading Level	Correct Factor	Measurement	Limit	Margin	Antenna Height	Table Degree	Comment
		MHz	dBuV	dB	dBuV/m	dBuV/m	dB	cm	degree	
1	*	2460.926	96.49	-3.39	93.10	74.00	19.10			peak
2		2483.500	52.01	-3.38	48.63	74.00	-25.37			peak

Polarization: Horizontal

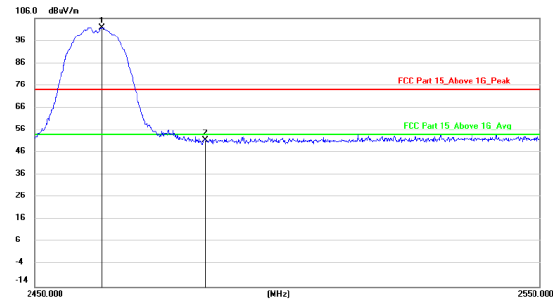

No.	Mk.	Freq.	Reading Level	Correct Factor	Measurement	Limit	Margin	Antenna Height	Table Degree	Comment
		MHz	dBuV	dB	dBuV/m	dBuV/m	dB	cm	degree	
1	*	2462.998	104.99	-3.40	101.59	74.00	27.59			peak
2		2483.500	54.96	-3.38	51.58	74.00	-22.42			peak

Test Mode: IEEE 802.11g-Low
Polarization: Vertical

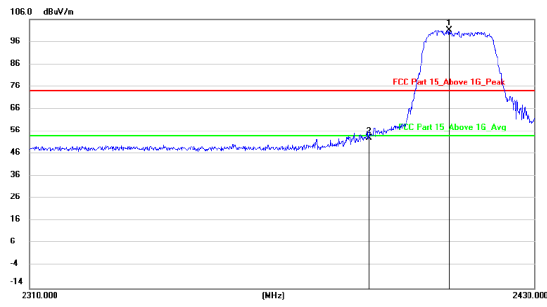

No.	Mk.	Freq.	Reading Level	Correct Factor	Measurement	Limit	Margin	Antenna Height	Table Degree	Comment
		MHz	dBuV	dB	dBuV/m	dBuV/m	dB	cm	degree	
1	*	2409.372	104.43	-3.40	101.03	74.00	27.03			peak
2		2390.000	56.49	-3.40	53.09	74.00	-20.91			peak

Polarization: Horizontal

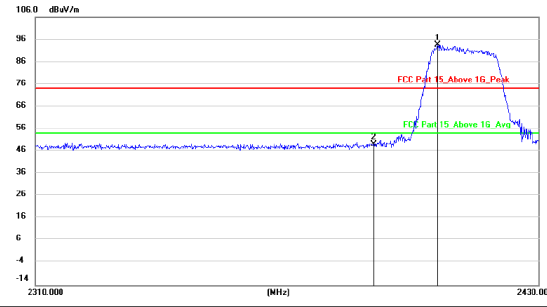

No.	Mk.	Freq.	Reading Level	Correct Factor	Measurement	Limit	Margin	Antenna Height	Table Degree	Comment
		MHz	dBuV	dB	dBuV/m	dBuV/m	dB	cm	degree	
1	*	2405.463	96.91	-3.41	93.50	74.00	19.50			peak
2		2390.000	52.48	-3.40	49.08	74.00	-24.92			peak

Test Mode: IEEE 802.11g-High
Polarization: Vertical

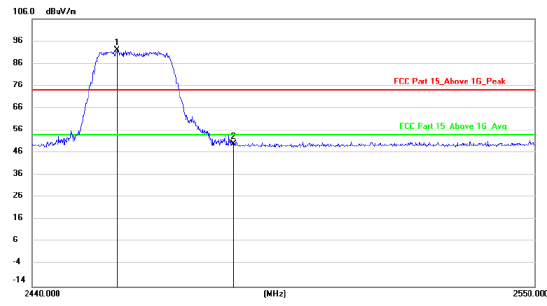

No.	Mk.	Freq.	Reading Level	Correct Factor	Measurement	Limit	Margin	Antenna Height	Table Degree	Comment
		MHz	dBuV	dB	dBuV/m	dBuV/m	dB	cm	degree	
1	*	2458.288	95.53	-3.39	92.14	74.00	18.14			peak
2		2483.500	53.40	-3.38	50.02	74.00	-23.98			peak

Polarization: Horizontal

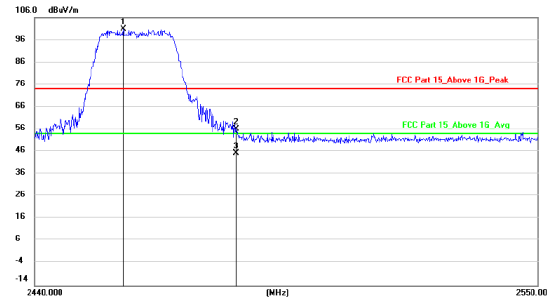

No.	Mk.	Freq.	Reading Level	Correct Factor	Measurement	Limit	Margin	Antenna Height	Table Degree	Comment
		MHz	dBuV	dB	dBuV/m	dBuV/m	dB	cm	degree	
1	*	2459.048	104.00	-3.39	100.61	74.00	26.61			peak
2		2483.500	59.57	-3.38	56.19	74.00	-17.81			peak
3		2483.500	48.77	-3.38	45.39	54.00	-8.61			AVG

Test Mode: IEEE 802.11n20-Low
Polarization: Vertical

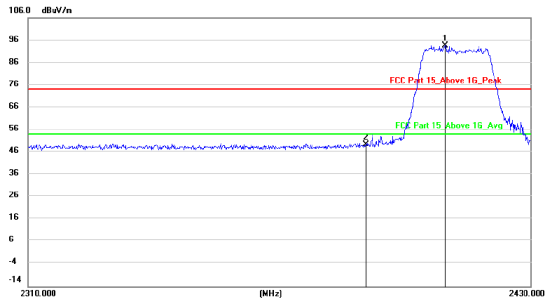

No.	Mk.	Freq.	Reading Level	Correct Factor	Measurement	Limit	Margin	Antenna Height	Table Degree	Comment
		MHz	dBuV	dB	dBuV/m	dBuV/m	dB	cm	degree	
1	*	2409.127	96.91	-3.40	93.51	74.00	19.51	peak		
2		2390.000	52.72	-3.40	49.32	74.00	-24.68	peak		

Polarization: Horizontal

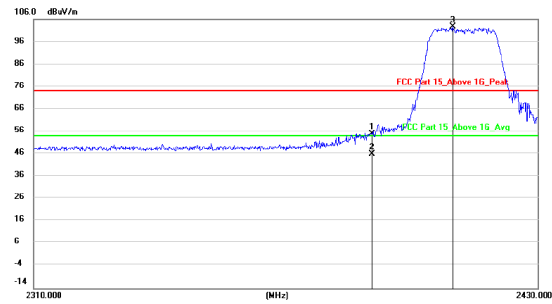

No.	Mk.	Freq.	Reading Level	Correct Factor	Measurement	Limit	Margin	Antenna Height	Table Degree	Comment
		MHz	dBuV	dB	dBuV/m	dBuV/m	dB	cm	degree	
1		2390.000	58.17	-3.40	54.77	74.00	-19.23	peak		
2		2390.000	49.25	-3.40	45.85	74.00	-8.15	AVG		
3	*	2409.372	105.88	-3.40	102.48	74.00	28.48	peak		

Test Mode: IEEE 802.11n20-High
Polarization: Vertical

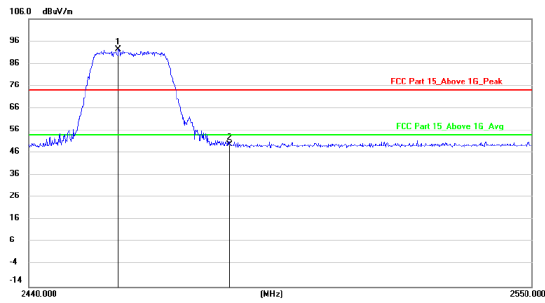

No.	Mk.	Freq.	Reading Level	Correct Factor	Measurement	Limit	Margin	Antenna Height	Table Degree	Comment
		MHz	dBuV	dB	dBuV/m	dBuV/m	dB	cm	degree	
1	*	2459.374	95.06	-3.39	92.27	74.00	18.27	peak		
2		2483.500	53.03	-3.38	49.65	74.00	-24.35	peak		

Polarization: Horizontal

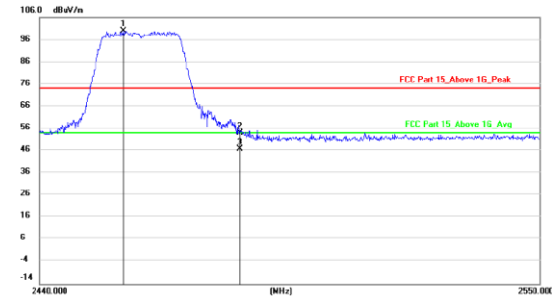

No.	Mk.	Freq.	Reading Level	Correct Factor	Measurement	Limit	Margin	Antenna Height	Table Degree	Comment
		MHz	dBuV	dB	dBuV/m	dBuV/m	dB	cm	degree	
1	*	2458.179	103.22	-3.39	99.83	74.00	25.83	peak		
2		2483.500	57.44	-3.38	54.06	74.00	-19.94	peak		
3		2483.500	50.20	-3.38	46.82	74.00	-7.18	AVG		

Test Mode: IEEE 802.11n40-Low
Polarization: Vertical

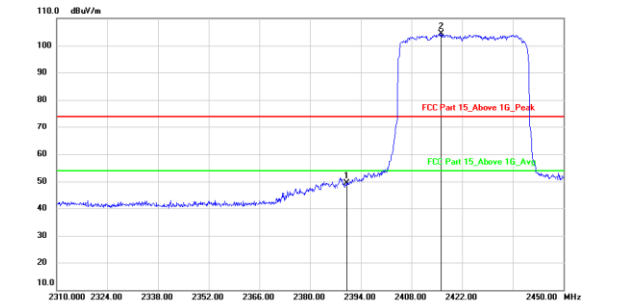

No.	Mk.	Freq.	Reading Level	Correct Factor	Measurement	Limit	Margin	Antenna Height	Table Degree	Comment
		MHz	dBuV	dB	dBuV/m	dBuV/m	dB	cm	degree	
1		2390.000	52.73	-3.40	49.33	74.00	-24.67			peak
2	*	2416.260	107.75	-3.41	104.34	74.00	30.34			peak

Polarization: Horizontal

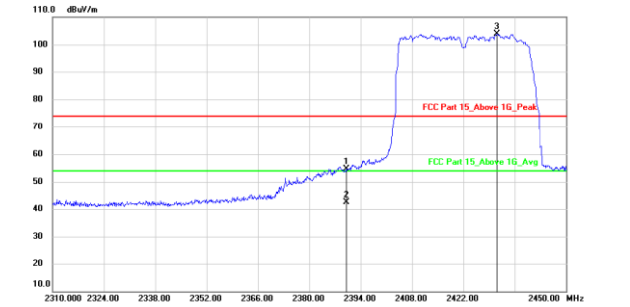

No.	Mk.	Freq.	Reading Level	Correct Factor	Measurement	Limit	Margin	Antenna Height	Table Degree	Comment
		MHz	dBuV	dB	dBuV/m	dBuV/m	dB	cm	degree	
1		2390.000	57.92	-3.40	54.52	74.00	-19.48			peak
2		2390.000	45.81	-3.40	42.41	54.00	-11.59			AVG
3	*	2431.240	107.36	-3.40	103.96	74.00	29.96			peak

Test Mode: IEEE 802.11n40-High
Polarization: Vertical

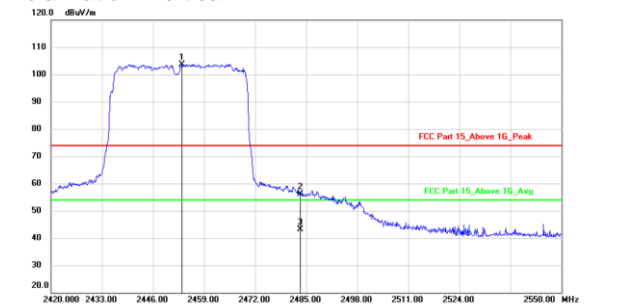

No.	Mk.	Freq.	Reading Level	Correct Factor	Measurement	Limit	Margin	Antenna Height	Table Degree	Comment
		MHz	dBuV	dB	dBuV/m	dBuV/m	dB	cm	degree	
1	*	2453.280	107.11	-3.39	103.72	74.00	29.72			peak
2		2483.500	59.50	-3.38	56.12	74.00	-17.88			peak
3		2483.500	46.39	-3.38	43.01	54.00	-10.99			AVG

Polarization: Horizontal

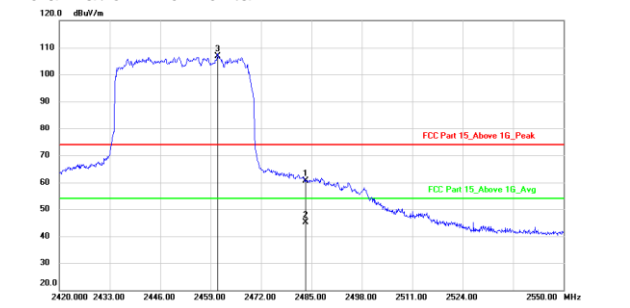

No.	Mk.	Freq.	Reading Level	Correct Factor	Measurement	Limit	Margin	Antenna Height	Table Degree	Comment
		MHz	dBuV	dB	dBuV/m	dBuV/m	dB	cm	degree	
1		2483.500	64.13	-3.38	60.75	74.00	-13.25			peak
2		2483.500	48.63	-3.38	45.25	54.00	-8.75			AVG
3	*	2460.820	110.17	-3.39	106.78	74.00	32.78			peak

Note: 1. *:Maximum data; x:Over limit; !:over margin.
2.Measurement=Reading Level + Correct Factor; Correct Factor=Antenna Factor + Cable Loss.

Test mode: 802.11b

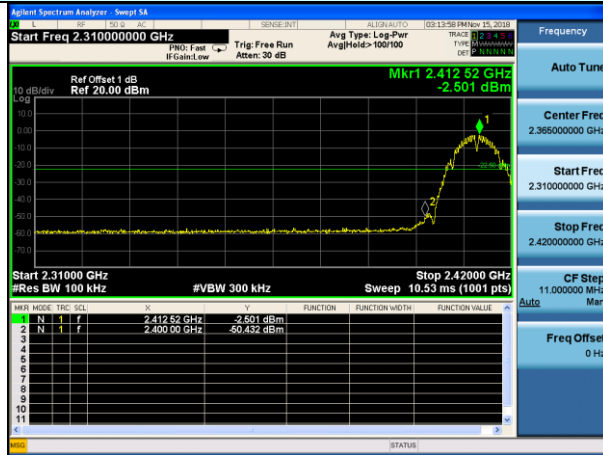

Lowest channel

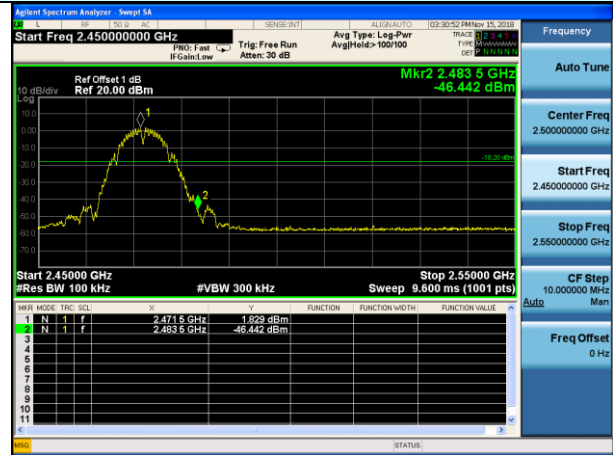

Highest channel

Test mode: 802.11g

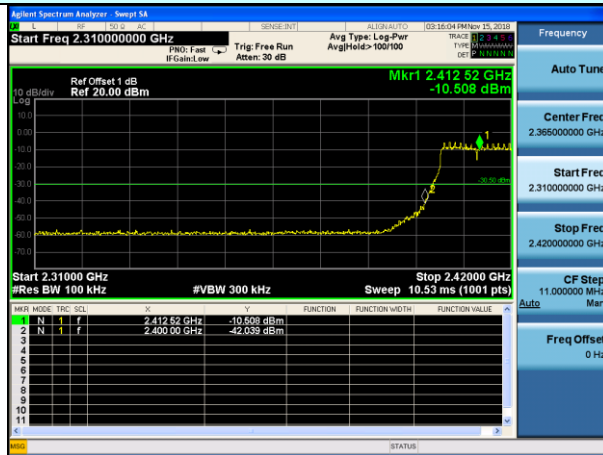

Lowest channel



Highest channel

Test mode: 802.11n(HT20)

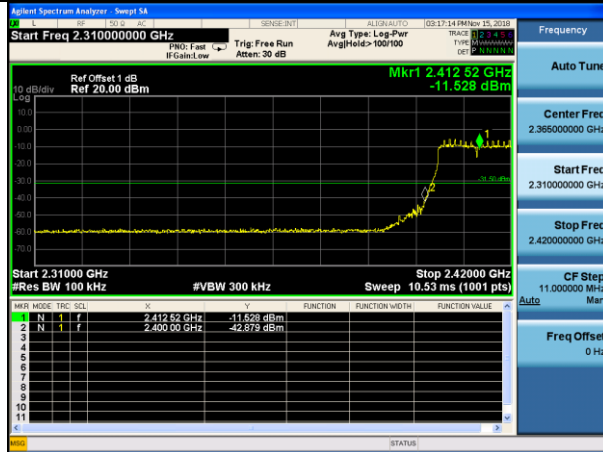

Lowest channel

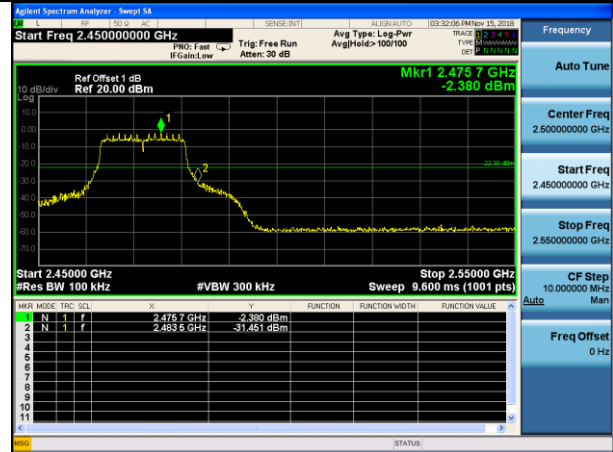

Highest channel

Test mode: 802.11n(HT40)

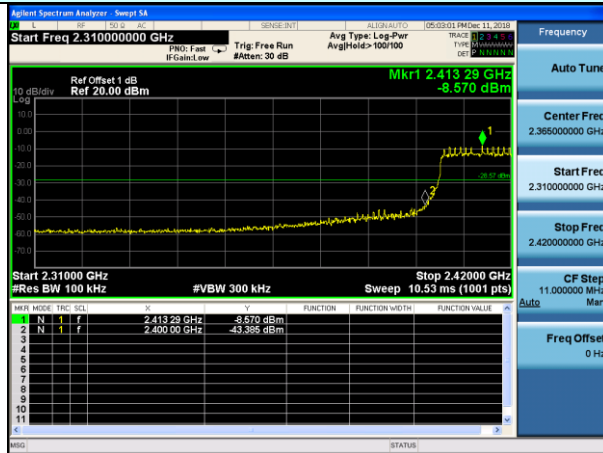

Lowest channel



Highest channel

9. FREQUENCY STABILITY

9.1. Test limit

Please refer section RSS-Gen.

Regulation RSS-Gen If the frequency stability of the licence-exempt radio apparatus is not specified in the applicable RSS, the fundamental emissions of the radio apparatus should be kept within at least the central 80% of its permitted operating frequency band in order to minimize the possibility of out-of-band operation. In addition, its occupied bandwidth shall be entirely outside the restricted bands and the prohibited TV bands of 54-72 MHz, 76-88 MHz, 174-216 MHz, and 470-602 MHz, unless otherwise indicated.

9.2. Test Procedure

The following equipment are installed on the emission measurement to meet the commission requirements and operating regulations in a manner which tends to maximize its emission characteristics in normal application.

9.3. Test Setup

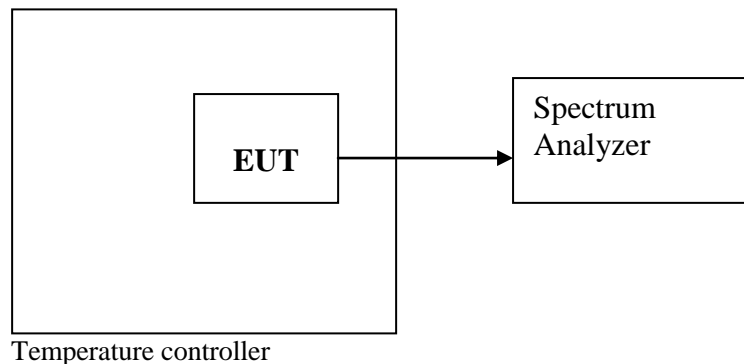

9.4. Test Results

PASS.

Detailed information please see the following page.

Assigned Frequency(MHz): 2412MHz				
Voltage	Temperature	Measured Frequency (MHz)	Frequency stability(MHz)	Limit(MHz)
Low DC 6.1V	+20°C	2412.988	-0.012	±0.020
Normal DC 7.2V	-20°C	2411.992	-0.008	±0.020
	-10°C	2411.995	-0.005	±0.020
	0°C	2411.992	-0.008	±0.020
	+10°C	2411.988	-0.012	±0.020
	+20°C	2411.996	-0.004	±0.020
	+30°C	2411.993	-0.007	±0.020
	+40°C	2411.989	-0.011	±0.020
	+50°C	2411.991	-0.009	±0.020
High DC 8.3V	+20°C	2411.986	-0.014	±0.020

10.ANTENNA REQUIREMENT

10.1.Standard Requirement

An intentional radiator shall be designed to ensure that no antenna other than that furnished by the responsible party shall be used with the device. The use of a permanently attached antenna or of an antenna that uses a unique coupling to the intentional radiator shall be considered sufficient to comply with the provisions of this Section. The manufacturer may design the unit so that a broken antenna can be replaced by the user, but the use of a standard antenna jack or electrical connector is prohibited.

10.2.Antenna Connected Construction

The antenna connector is unique antenna and no consideration of replacement. Please see EUT photo for details.

10.3.Results

The EUT antenna is internal Antenna. It complies with the standard requirement.

-----THE END OF REPORT-----