



RF-BM-2652P2 Specification

Version 1.0

ShenZhen Rfstar Technology Co.,Ltd

目录

- Overview 3
 - Brief introduction.....3
 - Application.....4
- Module parameters 5
- Module size and pin definition 6
- The considerations hardware design..... 8



● Overview

➤ Brief introduction

RF-BM-2652P2 is a multi-protocol 2.4GHz high transmission power wireless module based on Texas Instruments CC2652P, which is independently developed by ShenZhen Rfstar Technology Co.,Ltd.

In addition to integrating a high-performance ARM Cortex-M4F processor responsible for application logic with an ARM Cortex-M0 processor dedicated to the RF core, the module also features a 16-bit low-power sensor processing core. It has 352 KB programmable flash memory and 80 KB ultra-low leak RAM(SRAM).Support THREAD, ZigBee, low-power Bluetooth 5.0, 6LoWPAN, Wi-Fi and other wireless communication protocols.

The module has integrated industrial 48 MHz crystal oscillator and 32.768 kHz low power clock crystal oscillator. Contains a variety of peripherals, such as: I2C, I2S, UART, SPI,ADC and GPIO.

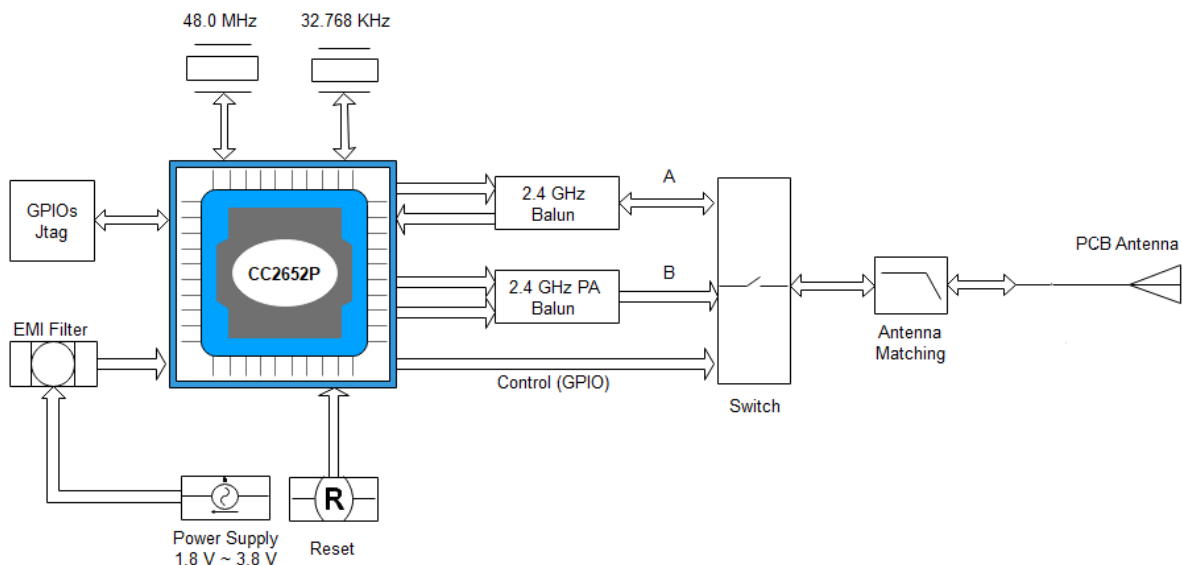

Figure 1. Diagram

➤ **Application**

RF-BM-2652P2 module can be widely used in a variety of occasions, such as:

- 2400 MHz to 2480 MHz ISM and SRD systems
 - Receive bandwidth as low as 4 kHz
- Residential and building automation
 - Building security systems: motion detectors, electronic door locks, door and window sensors, gateways
 - HVAC: Thermostat, wireless environmental sensor, HVAC system controller
 - Fire safety system: smoke detector, fire control panel
 - Video surveillance: IP camera
 - Garage door opener
 - Lift and escalator controls
- Smart grid and automatic meter reading
 - Water, gas and electricity meters
 - Heat distribution meter
 - the gateway
- Wireless sensor networks
 - Remote sensor applications
- Asset tracking and management
- Factory automation
- Wireless healthcare applications
- Energy harvesting applications
- Electronic Shelf Labels (ESL), etc

● Module parameters

Table 1. parameters

Chip	CC2652P
Working voltage	1.8 ~ 3.8 V, 3.3V is recommended
Working frequency	2402 MHz ~ 2480 MHz
Maximum transmitting power	+ 20 dBm
Receiving sensitivity	-100 dBm @ 802.15.4 (2.4 GHz) -105 dBm @ Bluetooth 125-kbps (LE Coded PHY)
SRAM	80 KB
FLASH	352 KB
GPIO	23 ↑
Power consumption	The current of receives: 6.9 mA The current of transmit: 7.3 mA @ 0 dBm 9.6 mA @ 5 dBm 22 mA @ 10 dBm 85 mA @ 20 dBm MCU 48 MHz (CoreMark): 3.4 mA (71 μA/MHz) Sensor Controller: 30.8 μA @ Low Power-Mode, 2 MHz 808 μA @ Active-Mode, 24 MHz sleep mode: 0.94 μA (RTC running, 80KB RAM and CPU maintained) shutdown: 150 nA
Encapsulation	SMT
Interface	UART, I ² S, I ² C, SPI, ADC
Size	30 x 16.4 mm
Operating temperature	- 40 °C ~ + 85 °C
Storage temperature	- 40 °C ~ + 125 °C

● Module size and pin definition

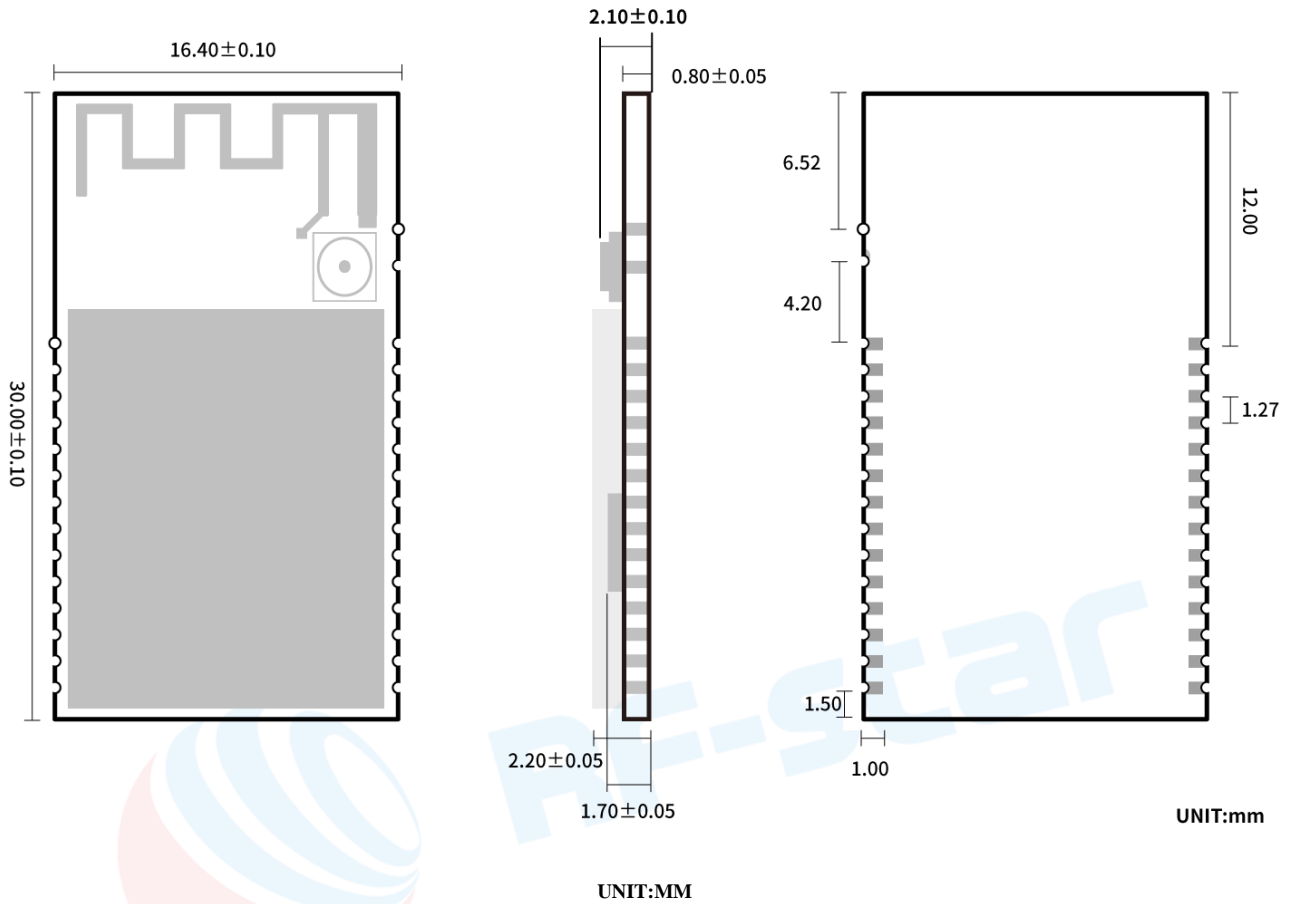

Figure 2. RF-BM-2652P2 size

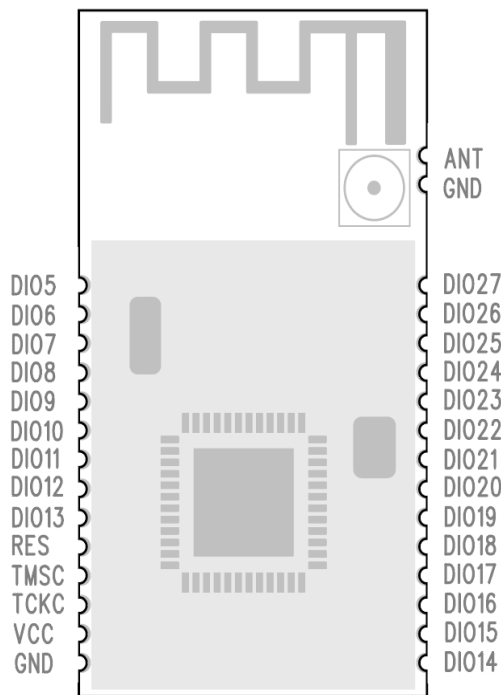

Figure 3. RF-BM-2652P2 pin

引脚序号	名称	功能	备注
1	DIO5	GPIO	High-drive capability
2	DIO6	GPIO	High-drive capability
3	DIO7	GPIO	High-drive capability
4	DIO8	GPIO	
5	DIO9	GPIO	
6	DIO10	GPIO	
7	DIO11	GPIO	
8	DIO12	GPIO	
9	DIO13	GPIO	
10	RESET	RESET	Reset, active low level
11	TMSC	JTAG_TMSC	High-drive capability
12	TCKC	JTAG_TCKC	
13	VCC	电源	The supply of module: 1.8V ~ 3.8V, 3.3V is recommended
14	GND	地	
15	DIO14	GPIO	
16	DIO15	GPIO	
17	DIO16	GPIO	GPIO,JTAG_TDO, high-drive capability
18	DIO17	GPIO	GPIO,JTAG_TDI, high-drive capability
19	DIO18	GPIO	
20	DIO19	GPIO	
21	DIO20	GPIO	
22	DIO21	GPIO	
23	DIO22	GPIO	
24	DIO23	GPIO	Analog capability
25	DIO24	GPIO	Analog capability
26	DIO25	GPIO	Analog capability
27	DIO26	GPIO	Analog capability
28	DIO27	GPIO	Analog capability
29	GND	地	
30	ANT	ANT	

Table 2. pin definition

● The considerations hardware design

- 1. It is recommended to use a DC regulated power supply to power the module. The ripple coefficient of the power supply should be as small as possible and the module should be reliably grounded. Please pay attention to the correct connection of the positive and negative poles of the power supply, such as the reverse connection may cause permanent damage to the module;
- 2. Please check the power supply to ensure that the module will be permanently damaged if the maximum power supply voltage is exceeded; Please check the stability of the power supply. The voltage cannot fluctuate greatly and frequently.
- 3. When designing the power supply circuit for the module, it is often recommended to keep more than 30% allowance, which is conducive to the long-term and stable work of the whole machine; The module should be as far away from the power supply, transformers, high-frequency wiring and other parts of large electromagnetic interference;
- 4. High-frequency digital wiring, high-frequency analog wiring and power wiring must avoid the lower part of the module. If it is really necessary to pass through the lower part of the module, assume that the module is welded on the Top Layer, and the Top Layer of the contact part of the module is covered with copper (all copper and well grounded). Must be close to the digital part of the module and routed in the Bottom Layer.
- 5. Assuming that the module is welded or placed in the Top Layer, it is also wrong to run wires randomly in the Bottom Layer or other layers, which will affect the stray and reception sensitivity of the module to varying degrees;
- 6. If there are devices with large electromagnetic interference around the module, it will also greatly affect the performance of the module. According to the intensity of the interference, it is recommended to stay away from the module appropriately.
- 7. Assuming that there are wiring (high-frequency digital, high-frequency analog, power wiring) with large electromagnetic interference around the module, it will also greatly affect the performance of the module. According to the intensity of the interference, it is recommended to keep away from the module appropriately.
- 8. If the communication line uses 5V level, the level conversion circuit must be used.
- 9. try to stay away from part of the physical layer is also 2.4GHz TTL protocol, such as: USB3.0;

Antenna information

PCB antenna Manufacturer: Shenzhen RF-star Technology Co.,Ltd. model: PCB ANT

Integral antenna Manufacturer: Dongguan Fangge Electronics Co., Ltd model: NB2458-044PCB

FCC Statement

FCC standards: FCC CFR Title 47 Part 15 Subpart C Section 15.247

PCB Antenna with antenna gain: 0dBi

Integral antenna with antenna gain: 4dBi

This device complies with part 15 of the FCC Rules. Operation is subject to the following two conditions: (1) This device may not cause harmful interference, and (2) this device must accept any interference received, including interference that may cause undesired operation.

Any Changes or modifications not expressly approved by the party responsible for compliance could void the user's authority to operate the equipment.

Note: This equipment has been tested and found to comply with the limits for a Class B digital device, pursuant to part 15 of the FCC Rules. These limits are designed to provide reasonable protection against harmful interference in a residential installation. This equipment generates, uses and can radiate radio frequency energy and, if not installed and used in accordance with the instructions, may cause harmful interference to radio communications. However, there is no guarantee that interference will not occur in a particular installation. If this equipment does cause harmful interference to radio or television reception, which can be determined by turning the equipment off and on, the user is encouraged to try to correct the interference by one or more of the following measures:

- Reorient or relocate the receiving antenna.
- Increase the separation between the equipment and receiver.
- Connect the equipment into an outlet on a circuit different from that to which the receiver is connected.
- Consult the dealer or an experienced radio/TV technician for help.

FCC Radiation Exposure Statement

The modular can be installed or integrated in mobile or fix devices. This modular cannot be installed in any portable device if without any further certify include C2PC with SAR. This modular complies with FCC RF radiation exposure limits set forth for an uncontrolled environment. This transmitter must not be co-located or operating in conjunction with any other antenna or transmitter. This modular must be installed and operated with a minimum distance of 20 cm between the radiator and user body.

If the FCC identification number is not visible when the module is installed inside another device, then the outside of the device into which the module is installed must also display a label referring to the enclosed module. This exterior label can use wording such as the following: “Contains Transmitter Module FCC ID: 2ABN2-BM2652P2 Or Contains FCC ID: 2ABN2-BM2652P2” When the module is installed inside another device, the user manual of the host must contain below warning statements;

1. This device complies with Part 15 of the FCC Rules. Operation is subject to the following two conditions:
 - (1) This device may not cause harmful interference.
 - (2) This device must accept any interference received, including interference that may cause undesired operation.

Note: This equipment has been tested and found to comply with the limits for a Class B digital device, pursuant to part 15 of the FCC Rules. These limits are designed to provide reasonable protection against harmful interference in a residential installation. This equipment generates, uses and can radiate radio frequency energy and, if not installed and used in accordance with the instructions, may cause harmful interference to radio communications. However, there is no guarantee that interference will not occur in a particular installation. If this equipment does cause harmful interference to radio or television reception, which can be determined by turning the equipment off and on, the user is encouraged to try to correct the interference by one or more of the following measures:

- Reorient or relocate the receiving antenna.
- Increase the separation between the equipment and receiver.
- Connect the equipment into an outlet on a circuit different from that to which the receiver is connected.
- Consult the dealer or an experienced radio/TV technician for help.

2. Changes or modifications not expressly approved by the party responsible for compliance could void the user's authority to operate the equipment.

The devices must be installed and used in strict accordance with the manufacturer's instructions as described in the user documentation that comes with the product.

Any company of the host device which install modular with Limit modular approval should perform the test of radiated & conducted emission and spurious emission,etc. according to FCC part 15C : 15.247 and 15.209 & 15.207 ,15B Class B requirement, Only if the test result comply with FCC part 15C : 15.247 and 15.209 & 15.207 ,15B Class B requirement, then the host can be sold legally.