

Operation Description for ISC-101A

1. Hardware Block diagram

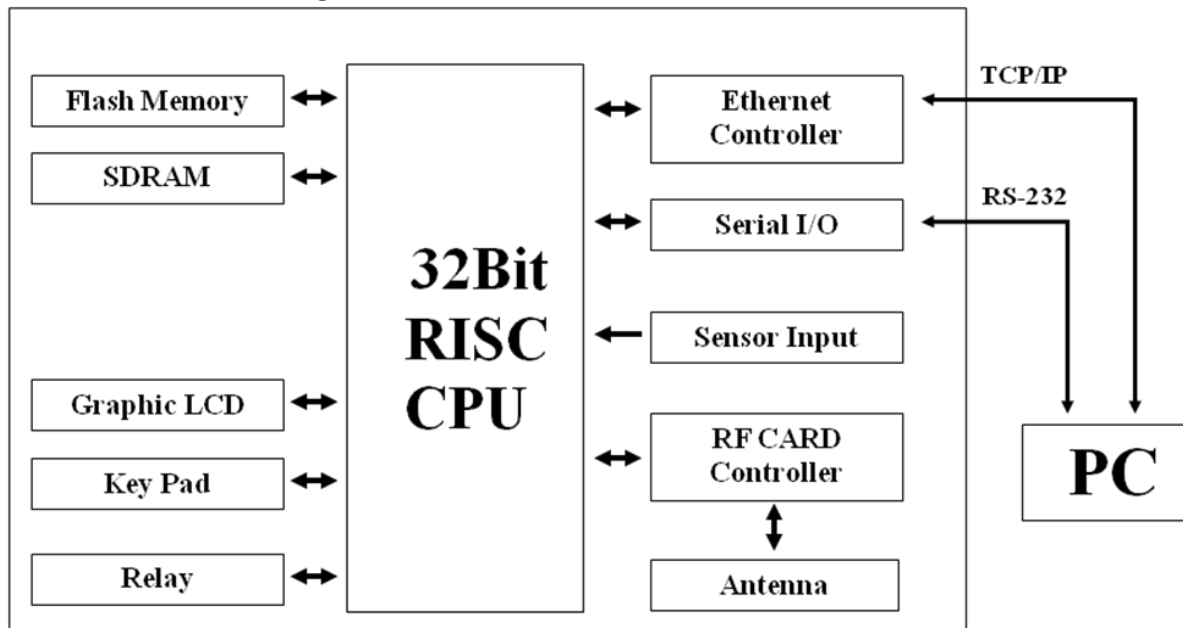

2. General

It supports various functions as follows

- User enrollment with user ID, RFID card and/or fingerprint
- User deletion with user ID
- User authentication using user ID and card
- User identification using card
- Configurable security modes
- Custom user display name and custom standby display message
- Standalone/Network communication via TCP/IP or RS-232
- Onboard menu configurable 2 inputs and 1 Relay output
- Various functions configurable with Key Pad and Graphic LCD

3. Operation

A. Card

- CPU reads card ID via RF Card Controller
- In Enroll process CPU write card ID to Flash Memory
- In authentication/identification process, CPU reads new card ID and compares enrolled card ID
- If authentication/ identification is successful, CPU display User ID on the LCD and drive the Relay

B. Delete User

- User can use the Key Pad, select Delete User function from the Program Menu
- User can delete single user data by entering the User ID
- User can delete all user data by select Delete All User function
- Completion of user deletion by erasing the user data that on a Flash Memory

C. Communication

- CPU communicate using TCP/IP, UDP protocol with the PC via Ethernet Controller
- CPU can RS-232 communication with the PC via Serial Input/Output
- CPU makes exchange with the PC about information for the operation of ISC-101A and User

D. Sensor

- Periodically, CPU checks the state of Sensor Input, notify to the PC or write to Flash Memory
- Sensor Input connected to Exit Button, CPU drives the relay