



BSC-401N

- Page1. MCU
- Page2. MEMORY
- Page3. ETHERNET
- Page4. AUDIO
- Page5. CAMERA
- Page6. UART
- Page7. IN/OUT
- Page8. POWER

저항, 콘덴서 기본 Size : 1608
저항, 콘덴서 별도 표기 Size 참조.

NO	CHANGE	DATE	SIGN
----	--------	------	------

1	Brian	2013 02 04	
---	-------	------------	--

MODEL BSC-401(ISC-401)

PART 0. INFO

DATE 2012/03/12

DESIGN

EXAMINE

APPROVAL

DRAWING NO IHD-A4C-120312-00

File BSC-401____.DSN

IDT INC



NO CHANGE DATE SIGN

1 Brian 2013 02 04

MODEL BSC-401(ISC-401)

PART 2. MEMORY

DATE 2012/03/12

DESIGN

EXAMINE

APPROVAL

DRAWING NO IHD-A4C-120312-00

File BSC-401____.DSN

IDT INC

PSRAM 4M : R29, 31 주입
PSRAM 8M : R28, 30, 32 주입

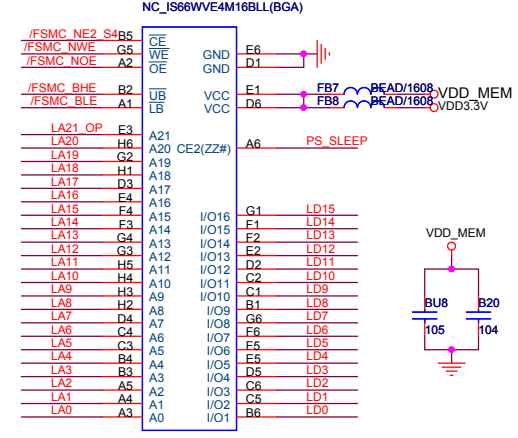
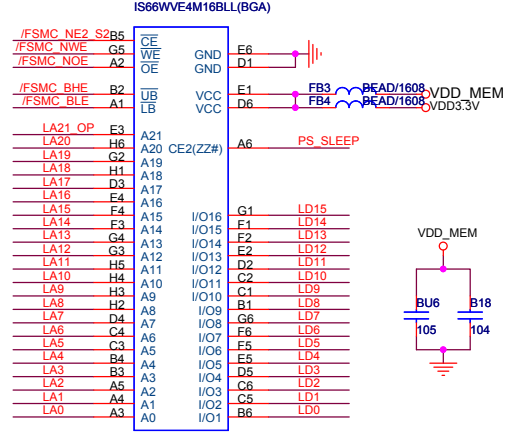
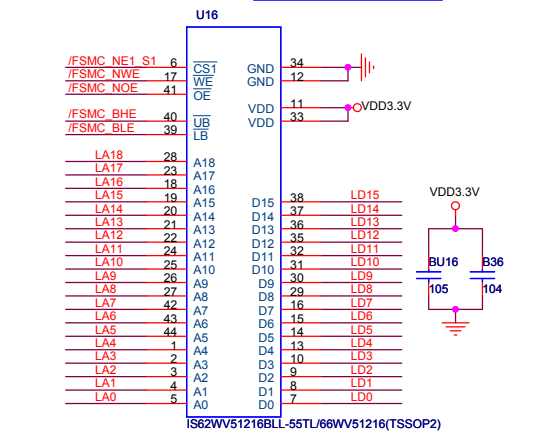
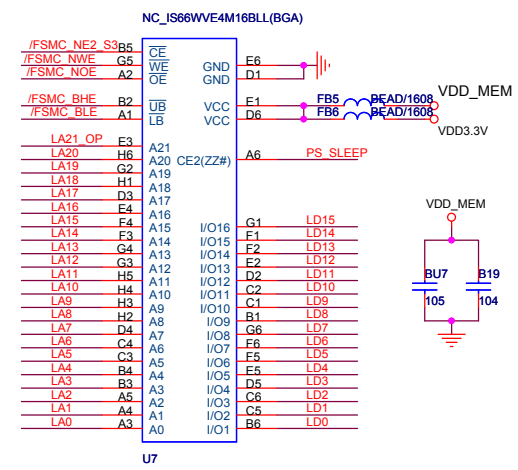
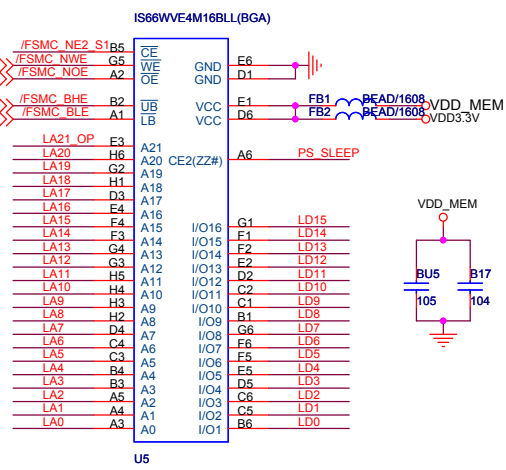
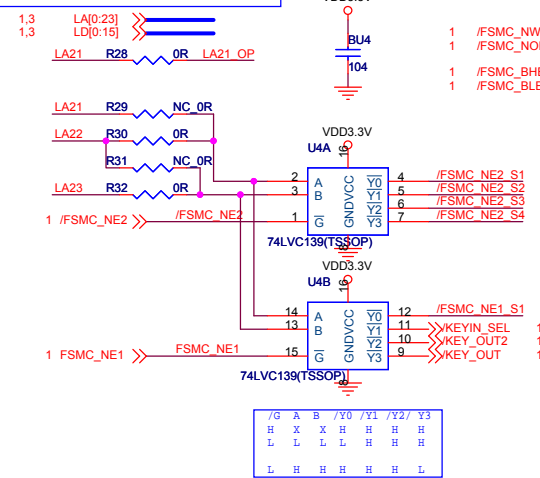

// 1M = 0x0010 0000
// 128M = 0x0800 0000
// 1G = 0x4000 0000
// 2G = 0x8000 0000

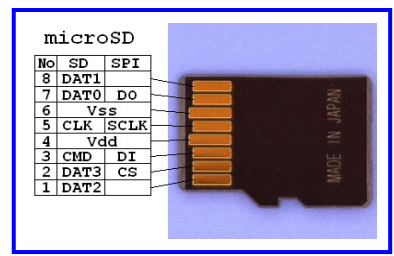
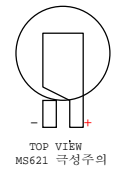
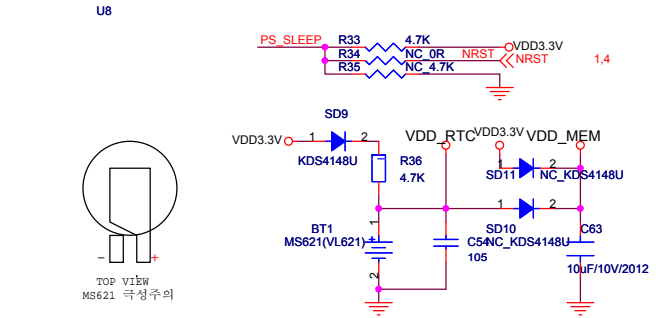
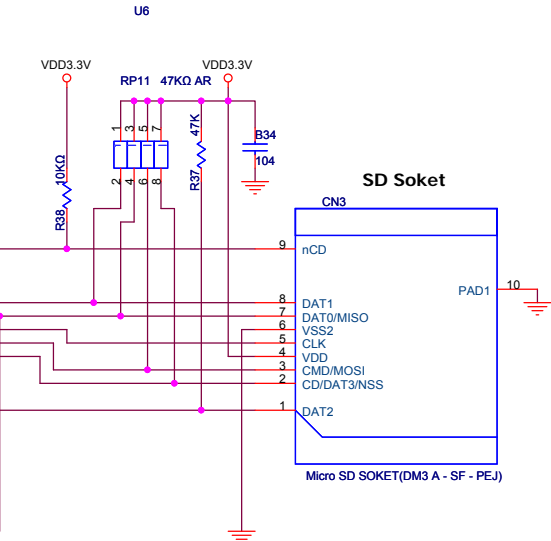
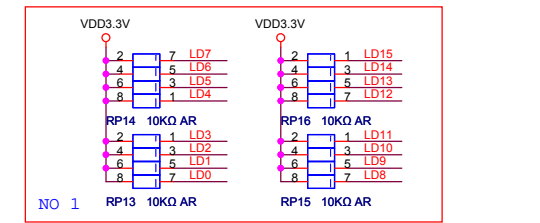



NO CHANGE DATE SIGN

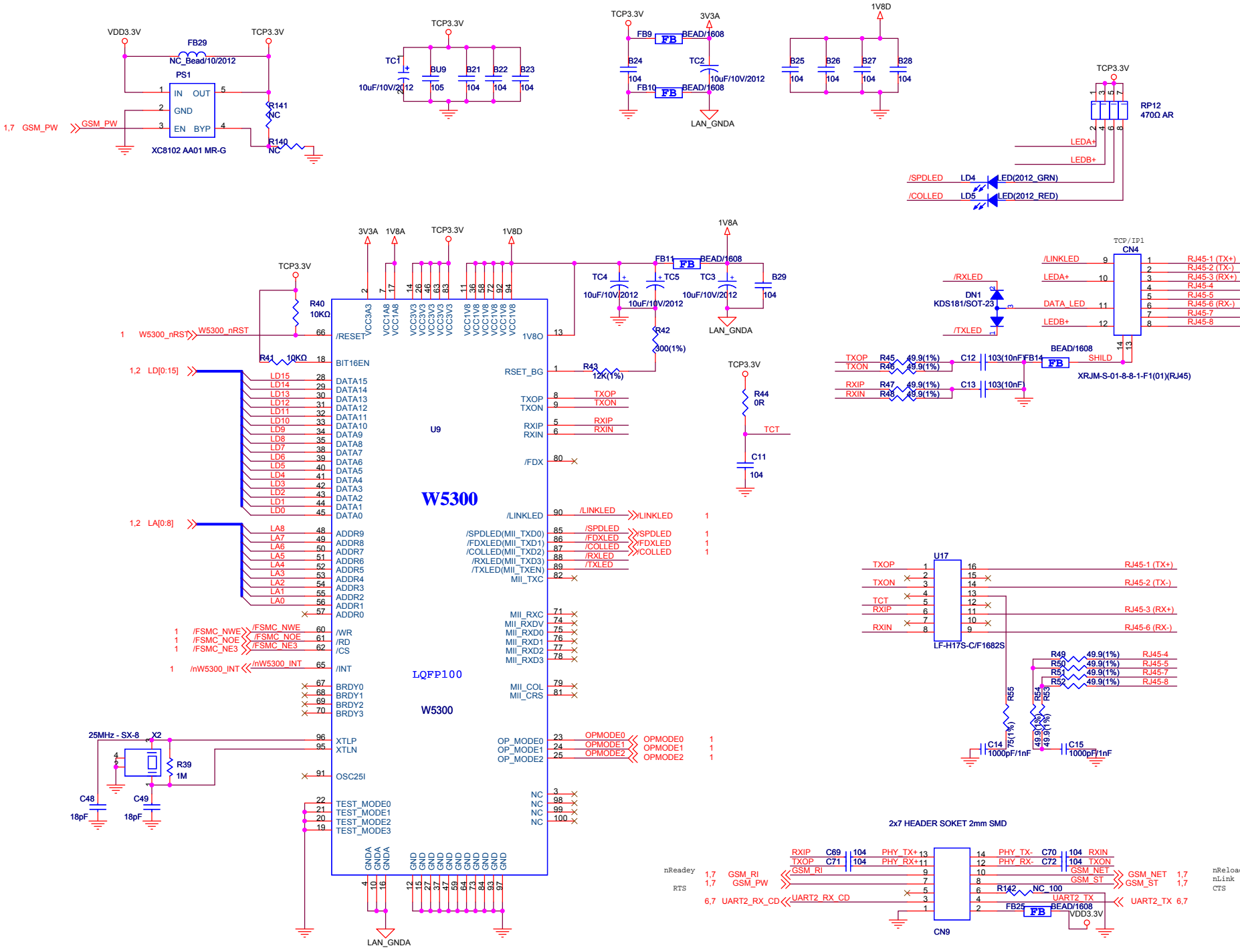

MODEL	BSC-401(ISC-401)
PART	3. ETHERNET
DATE	2012/03/12
DESIGN	
EXAMINE	
APPROVAL	
DRAWING NO	IHD-A4C-120312-00
File	BSC-401____.DSN

IDTI INC



NO	CHANGE	DATE	SIGN

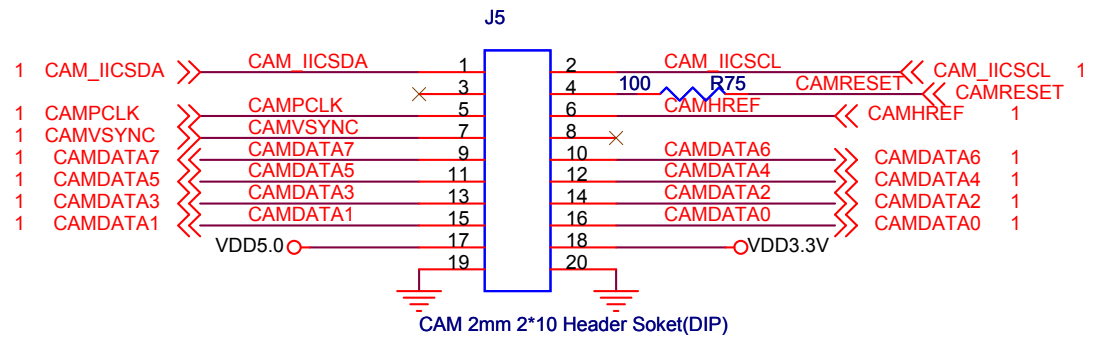

CAM 2mm 2*10 Header Scket(DIP)

CAM CONNECTOR

MODEL BSC-401(ISC-401)

PART 5. CAMERA

DATE 2012/03/12

DESIGN

EXAMINE

APPROVAL

DRAWING NO IHD-A4C-120312-00

File BSC-401____.DSN

IDT INC

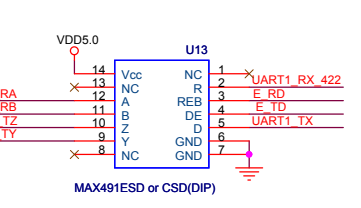
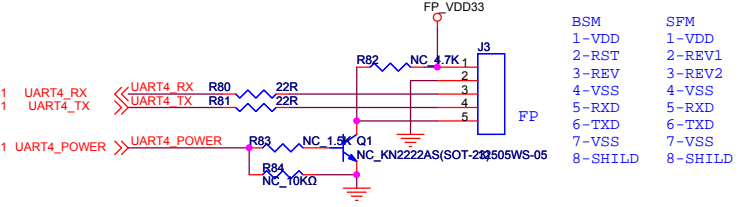
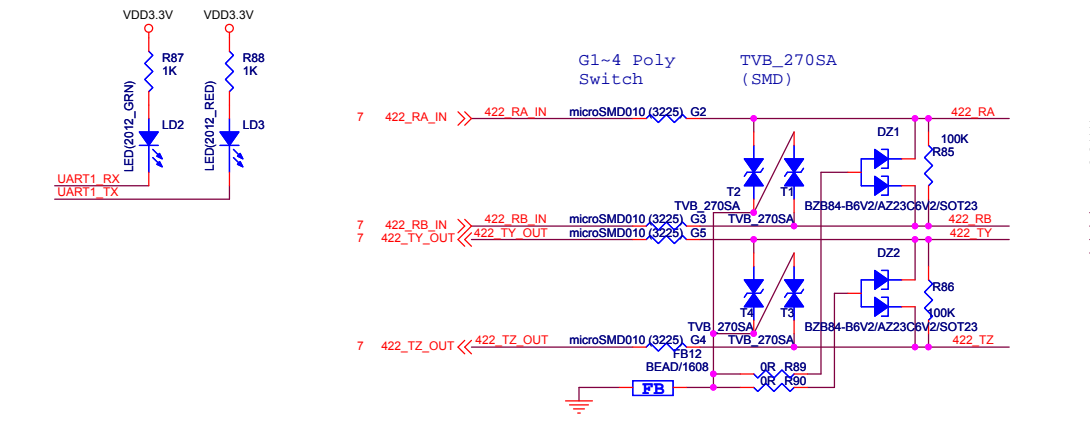
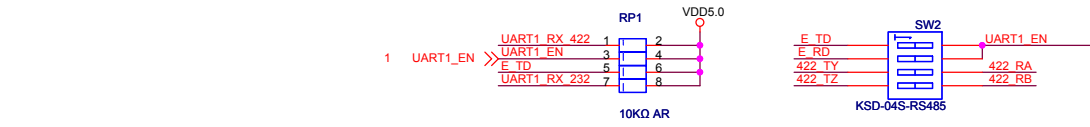
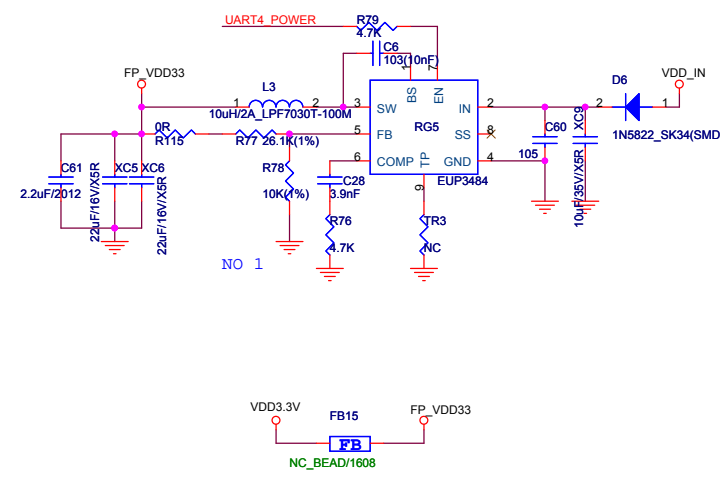
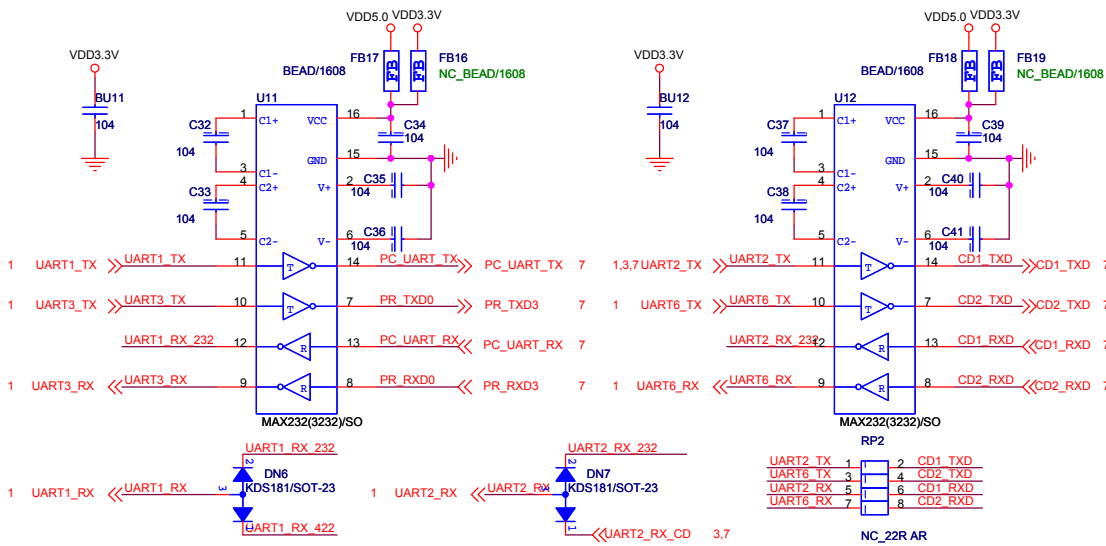

- | | |
|---------|---------|
| BSM | SFM |
| 1-VDD | 1-VDD |
| 2-RST | 2-REV1 |
| 3-REV | 3-REV2 |
| 4-VSS | 4-VSS |
| 5-RXD | 5-RXD |
| 6-TXD | 6-TXD |
| 7-VSS | 7-VSS |
| 8-SHILD | 8-SHILD |

MODEL BSC-401(ISC-401)

PART 6. UART

DATE 2012/03/12

DESIGN

EXAMINE

APPROVAL

DRAWING NO IHD-A4C-120312-00

File BSC-401____.DSN



NO	CHANGE	DATE	SIGN
1	Brian	2013 02 04	

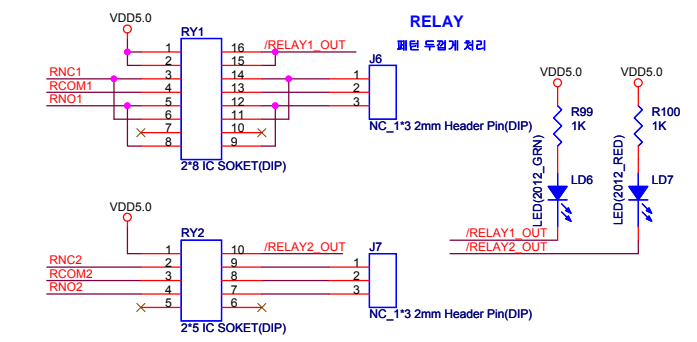
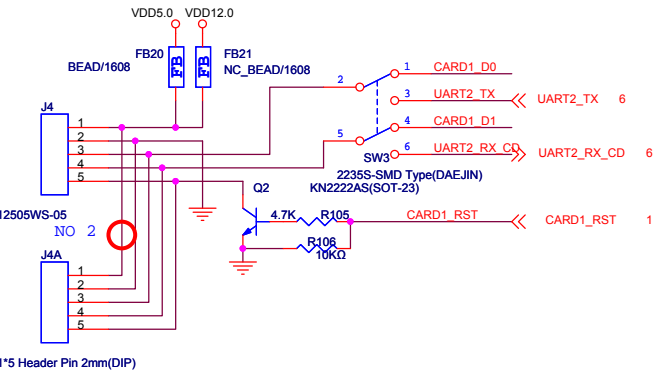
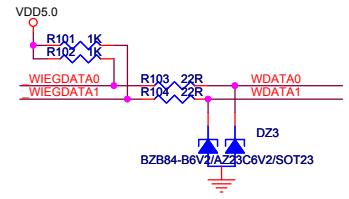
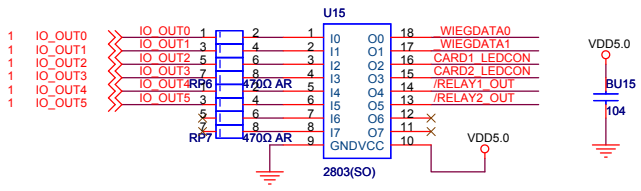
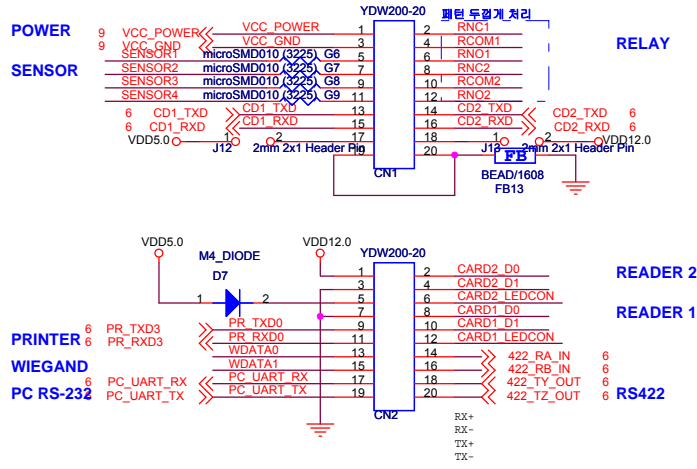
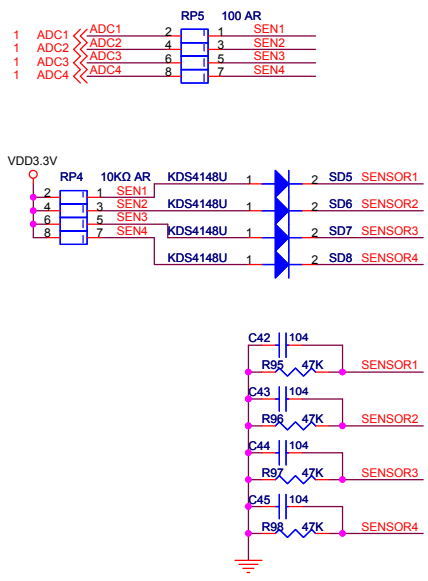
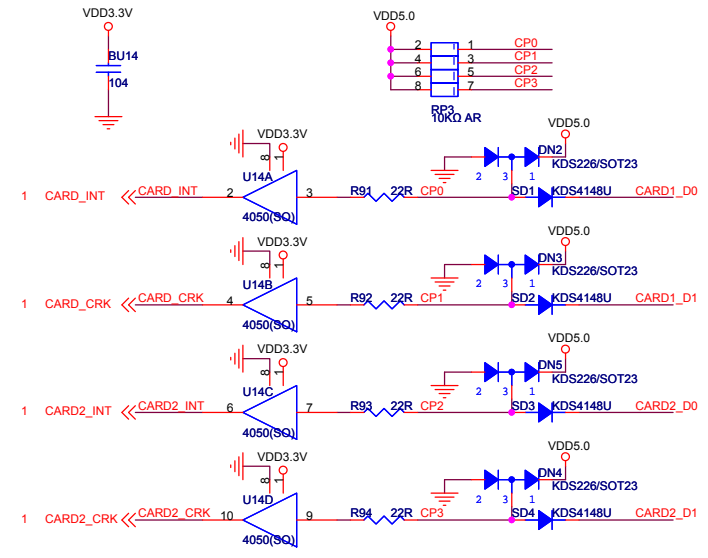

J4 pin1 -- J4A pin1 두집게.

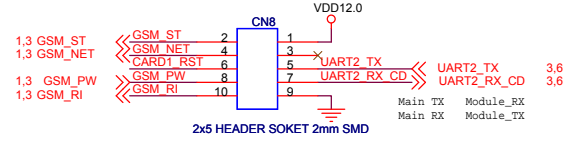

MODEL BSC-401(ISC-401)

PART 7. IN/OUT

DATE 2012/03/12

DESIGN

EXAMINE

APPROVAL

DRAWING NO IHD-A4C-120312-00

File BSC-401____.DSN

IDT INC



NO	CHANGE	DATE	SIGN
----	--------	------	------

1	Brian	2013 02 04	
---	-------	------------	--

MODEL BSC-401(ISC-401)

PART 8. POWER

DATE 2012/03/12

DESIGN

EXAMINE

APPROVAL

DRAWING NO IHD-A4C-120312-00

File BSC-401____.DSN

IDT INC

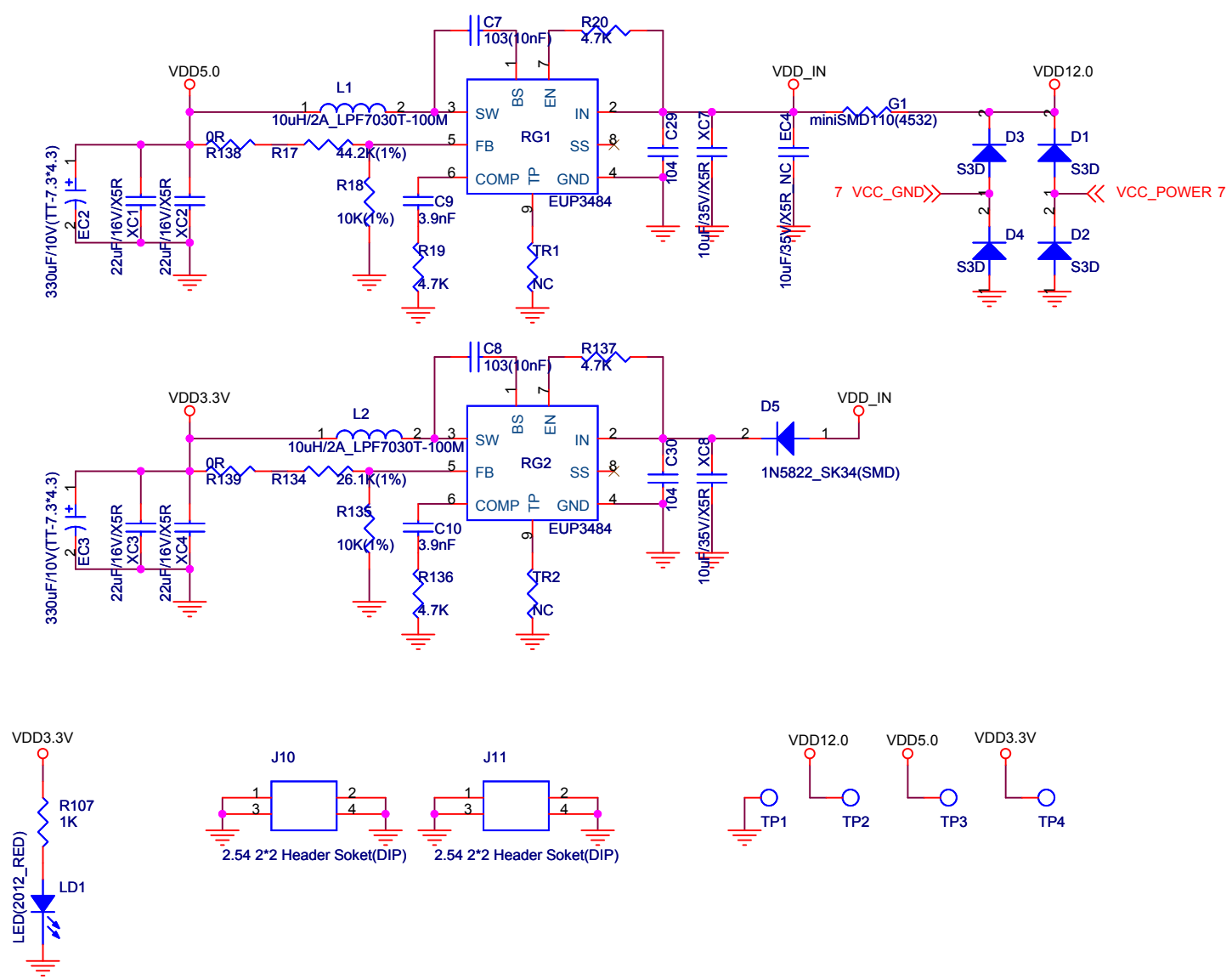

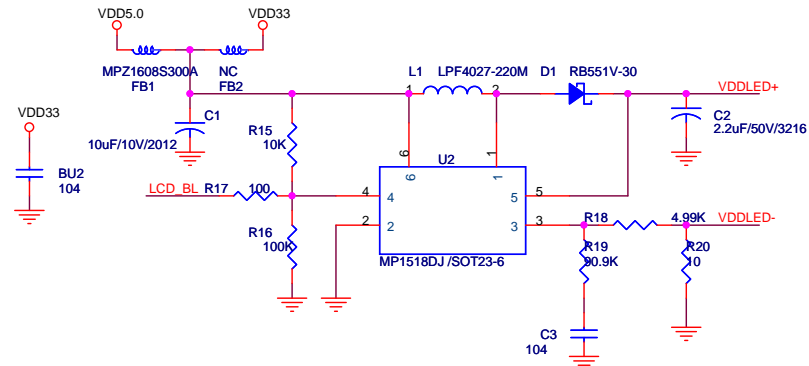
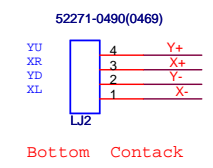
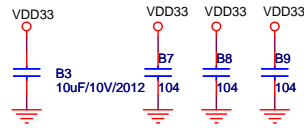
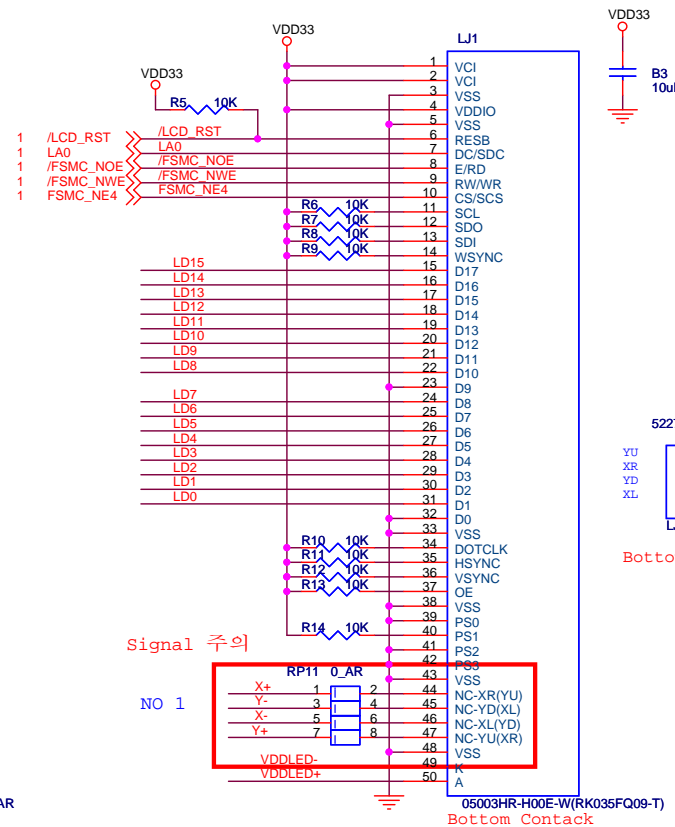
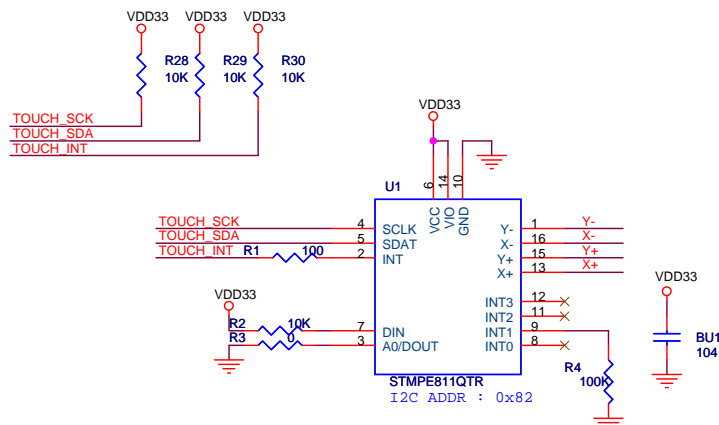

Signal 주의

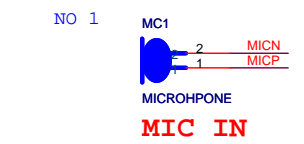
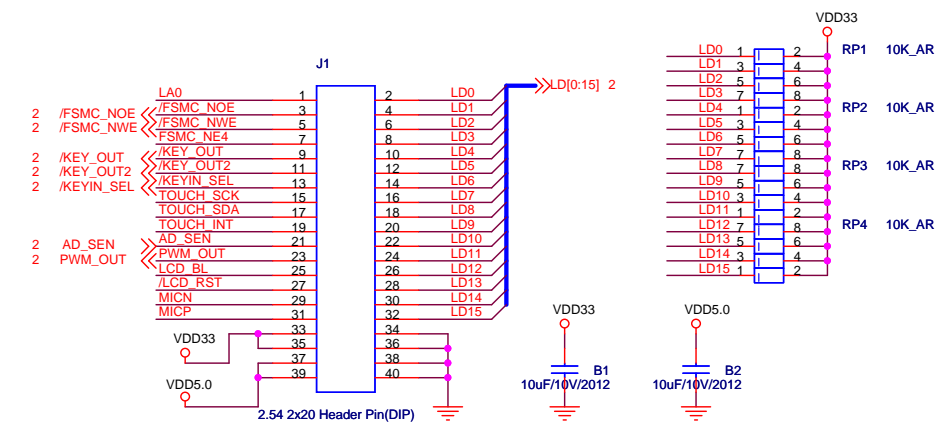
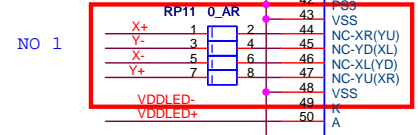

MIC1 조립시 LED 지지대
고무 1mm 사용.

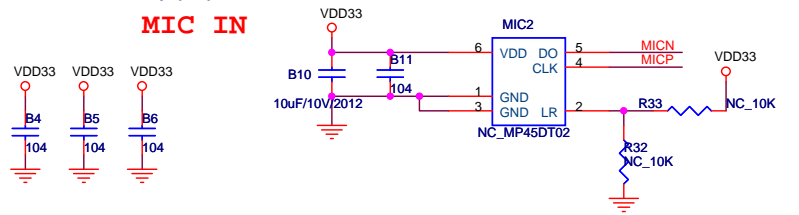

NO 1
RP11 추가.

MODEL BSC-401(ISC-401)

PART 1. LCD

DATE 2012/03/12

DESIGN

EXAMINE

APPROVAL

DRAWING NO IHD-A4C-120312-00

File BSC-401 KEY__.DSN

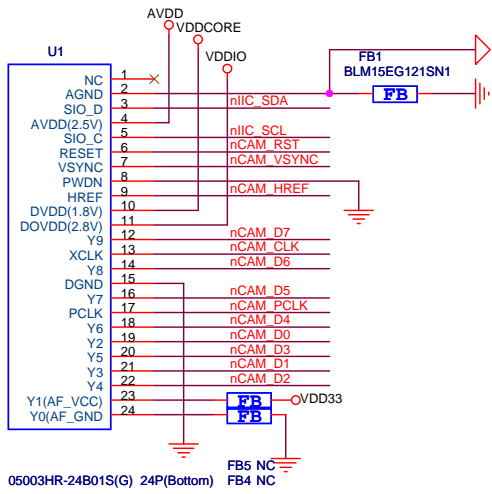

OV9655/OV9650/OV2460/OV3640

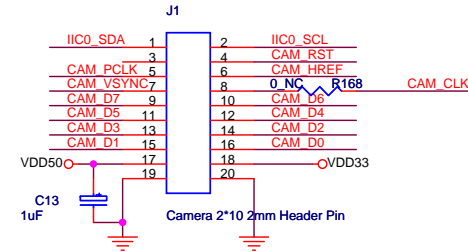
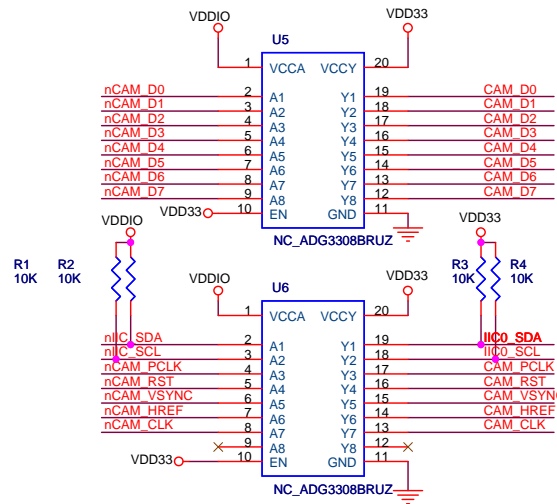
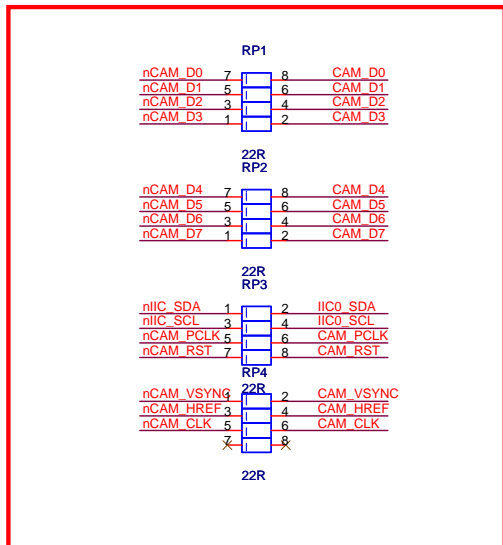
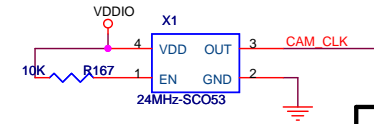
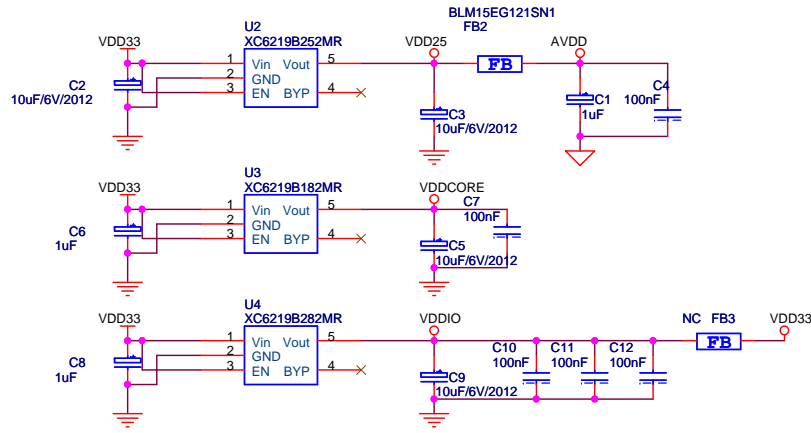

Extend Camera Socket



NO CHANGE DATE SIGN

MODEL BSC-401N

PART 1. CAMERA

DATE 2012/03/12

DESIGN

EXAMINE

APPROVAL

DRAWING NO IHD-A4C-120312-00

File BSC-401N Camera_DSN

IDT INC



NO CHANGE DATE SIGN

1 Brian 2013 02 04

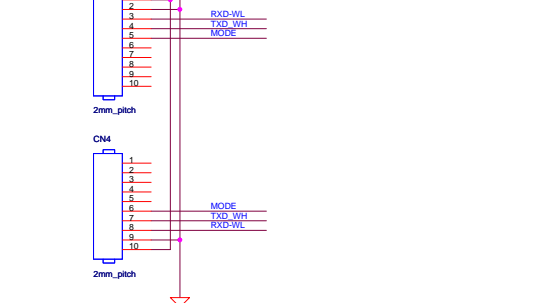
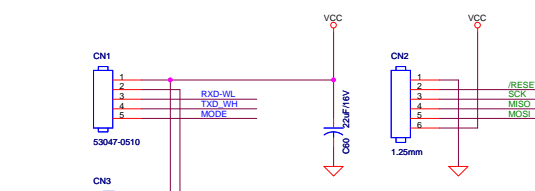
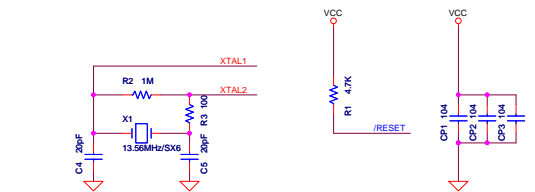
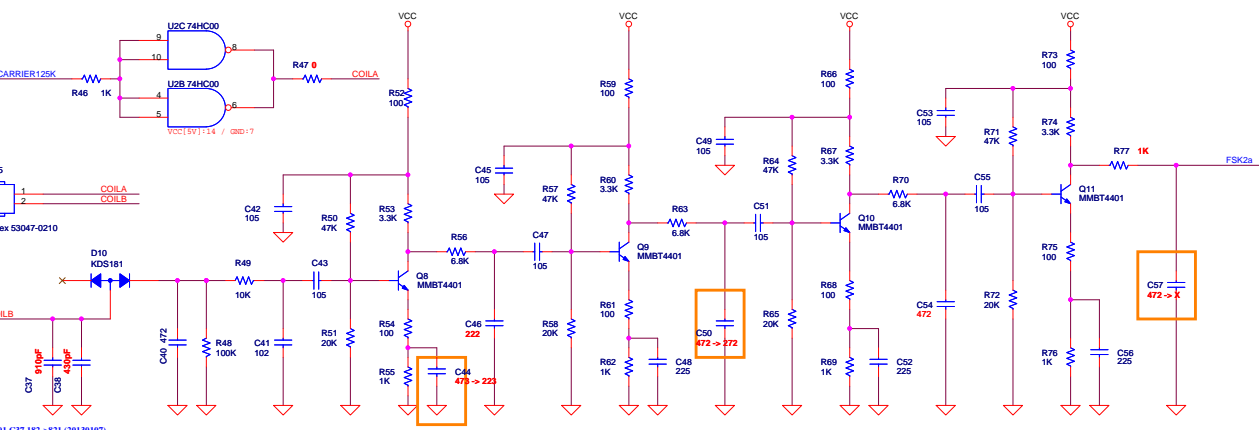
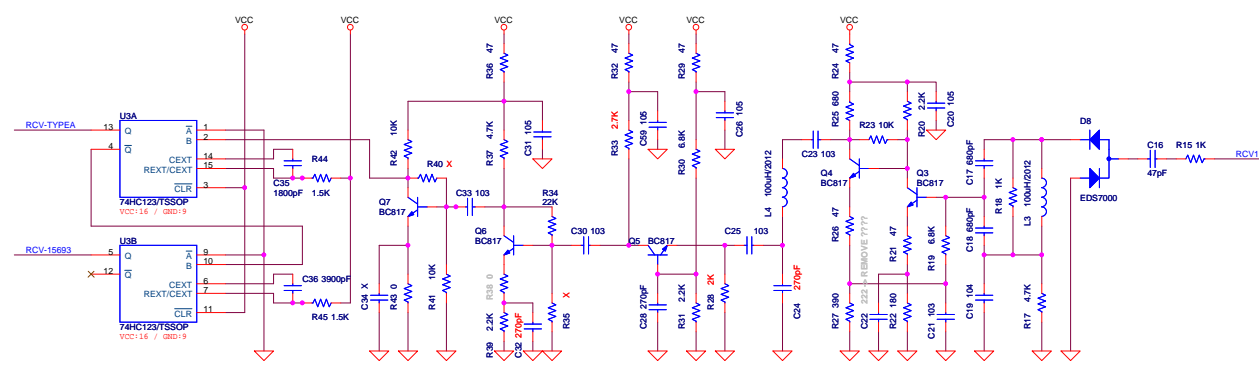
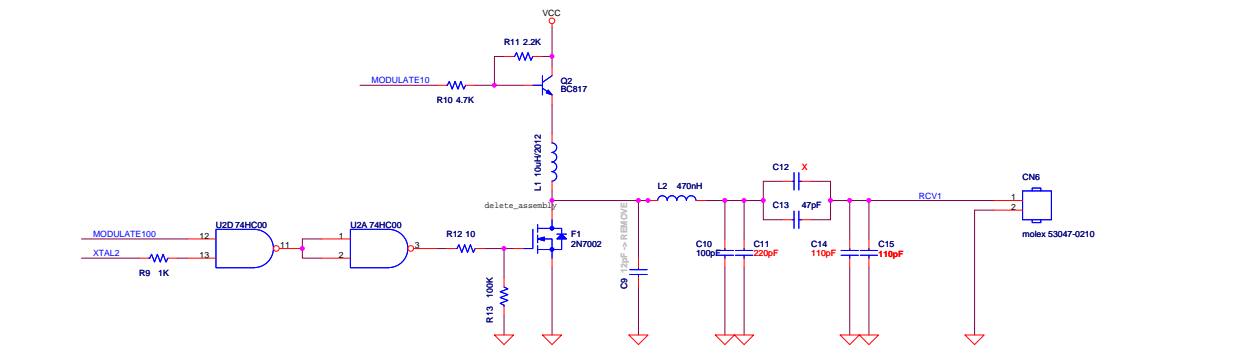
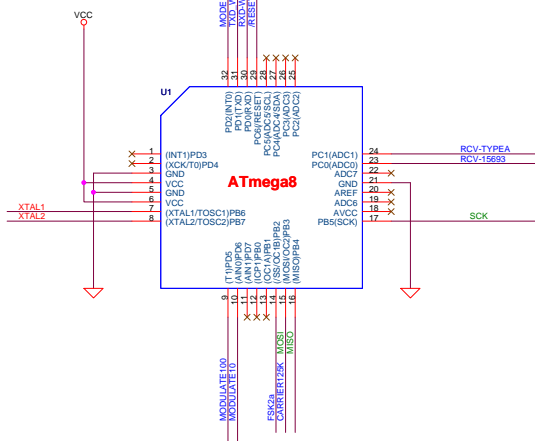

BSC-401 C37 182->821 (20130107)

MODEL BSC-401(1SC-401)

PART ISO14443A/
ISO15693/FSK/ASK

DATE 2012/03/12

DESIGN

EXAMINE

APPROVAL

DRAWING NO IHD-A4C-120312-00

File BSC-401 CARD...DSN

IDT INC