

Product Technical Spec Sheet

1. Product Overview

1.1 Product picture



1.2 Key Feature

- BK Bluetooth 4.0
- Compatibility: works with most Bluetooth smartphones, tablets, music devices, Bluetooth 2.1 or above
- Internal rechargeable Li-ion battery, single fully charge with 4-hour operating lifetime
- Voice prompt for convenient feedback during Bluetooth Mode
- Connectivity:
 - Audio Connections: 3.5mm Line in
 - Bluetooth profiles: A2DP, AVRCP, HFP
 - Bluetooth range: Line of sight, 10M or 30FT

2. Electrical Specification

2.1 Audio Performance:

- Driver: 1pcs 2" full range driver and 1pc bass enhance radiator
- RMS Output: 5W @10%
 - System SNR: >65 dB @ 1W
 - THD: <10% at the Max Volume
 - Loudness: SPL >65dB @ 1kHz sine wave
 - Frequency response: 90Hz – 20kHz

2.2 Power Solution:

- Built-in Lithium battery 3.7V 900mAh, single fully charged with 4-hour operating lifetime
- Micro USB charging port, 5V/500 mA battery charging, single fully charge time is 3hrs

2.3 Operation Instructions:

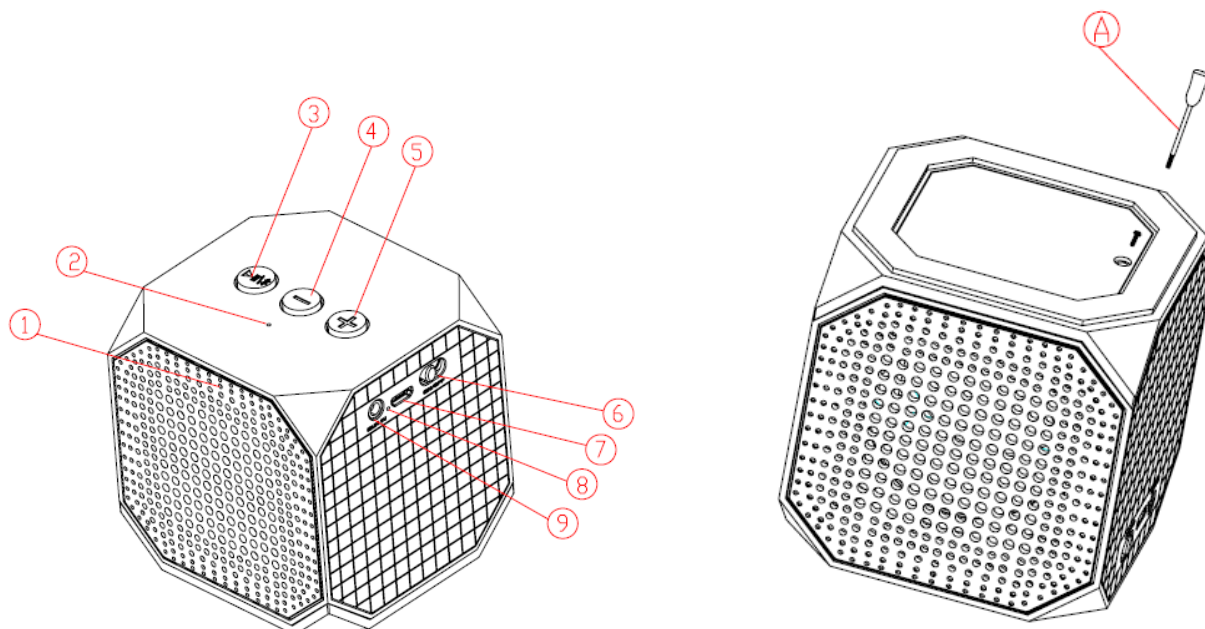

1. Mode indication LED
2. Mic
3. Short pressing for Play/Pause, 3's long pressing to cutting off connected device and waiting for pairing
4. short pressing for volume down
5. short pressing for volume up
6. Power on/off
7. Micro USB charging port
8. Charging indication LED
9. AUX-in
- A. **Battery compartment**

2.4 Light Indication:

1. Charging LED, charging---solid red, fully charged-LED off
2. Mode LED
 - Bluetooth mode, pairing-- blue fast flashing,
 - paired and connected--blue slow flashing
 - AUX-in mode, solid red
 -

2.5 Voice Prompt (for Bluetooth mode only):

1. power on-----“Welcome”
2. pairing-----“Waiting to connect to Bluetooth device” 1min a loop
3. paired and connected----“Connected to Bluetooth device”

3. Mechanical Specification

3.1 Dimension: 78X75X71 mm

3.2 Weight: TBD

3.3 Material and Finishing: ABS Plastic, matte Finishing, silicon gel , EVA mat

3.4 Color: Black, White, Yellow, Red, Blue, possible to make customized color subject to Buyer requirements

4. Packing

4.1 Color box or blister package:TBD

4.2 Box size: TBD

4.3 Carton size: TBD

4.4 Accessories: 1pc Micro USB charge cable, 1pc 3.5mm audio cable, 1pc QSG, others depends on buyer's requirements

5. Reliability

5.1 General Operating Temperature: 0 - 40 °C

5.2 General Humidity test: 90% (Operating @ 40 °C)

5.3 General storage temperature: -20 - 65 °C

5.4 Heat Storage test: 98.5 hours with Temp Cycling

5.5 Vibration test: 0.75 mm, 13Hz to 25Hz, 3 axis, 30 mins

5.6 Drop test (in pack outer carton): 1 corner, 3 edges, 6 faces

5.7 Drop test (out of pack drop test): 3 faces when opened, two faces when close at 1m height

5.8 Product Life: 36 Months (3 years) with 1 year limited warranty

5.9 Button life: 5000 times pressing

FCC Warning

This device complies with Part 15 of the FCC Rules. Operation is subject to the following two conditions:

(1) This device may not cause harmful interference, and (2) this device must accept any interference received, including interference that may cause undesired operation.

NOTE: Any changes or modifications to this unit not expressly approved by the party responsible for compliance could void the user's authority to operate the equipment.