



America

---

**Choose certainty.  
Add value.**

# Report On

Application for Grant of Equipment Authorization of the  
ViaSat, Inc.

L-Band Satellite Fixed Terminal M2M FT2225 Terminal

FCC Part 15 Subpart C §15.247 (FHSS)

IC RSS-247 Issue 1 May 2015

IC RSS-Gen Issue 4, November 2014

Report No. SD72107151C-0615

October 2015



**REPORT ON** Radio Testing of the  
ViaSat, Inc.  
L-Band Satellite Fixed Terminal

**TEST REPORT NUMBER** SD72107151C-0615

**PREPARED FOR** ViaSat, Inc.  
6155 El Camino Real  
Carlsbad, CA 92009  
USA

**CONTACT PERSON** Jason Soares  
Hardware Engineer  
(760) 893-4654  
Jason.Soares@viasat.com

**PREPARED BY**

  
Nikolay Shtin

**Name**  
Authorized Signatory  
Title: EMC Wireless Engineer

**APPROVED BY**

  
Ferdinand S. Custodio

**Name**  
Authorized Signatory  
Title: EMC/Senior Wireless Test Engineer

**DATED**

October 15, 2015



**Revision History**

SD72107151C-0615 ViaSat, Inc. L-Band Satellite Fixed Terminal M2M FT2225 Terminal					
DATE	OLD REVISION	NEW REVISION	REASON	PAGES AFFECTED	APPROVED BY
10/15/2015	Initial Release				Ferdinand Custodio



**CONTENTS**

<b>Section</b>	<b>Page No</b>
<b>1 REPORT SUMMARY .....</b>	<b>5</b>
1.1 Introduction .....	6
1.2 Brief Summary Of Results .....	7
1.3 Product Information .....	8
1.4 EUT Test Configuration .....	10
1.5 Deviations From The Standard .....	13
1.6 Modification Record .....	13
1.7 Test Methodology .....	13
1.8 Test Facility Location .....	13
1.9 Test Facility Registration .....	13
<b>2 TEST DETAILS .....</b>	<b>15</b>
2.1 Carrier Frequency Separation .....	16
2.2 Number Of Hopping Frequencies .....	19
2.3 Time Of Occupancy (Dwell Time) .....	21
2.4 20 dB Bandwidth .....	26
2.5 99% Emission Bandwidth .....	32
2.6 Peak Output Power .....	39
2.7 Band-Edge Compliance Of RF Conducted Emissions .....	42
2.8 Spurious RF Conducted Emissions .....	49
2.9 Spurious Radiated Emissions .....	55
2.10 Radiated Immediate Restricted Bands .....	65
2.11 Receiver Spurious Emissions .....	69
<b>3 TEST EQUIPMENT USED .....</b>	<b>70</b>
3.1 Test Equipment Used .....	71
3.2 Measurement Uncertainty .....	72
<b>4 DIAGRAM OF TEST SETUP .....</b>	<b>73</b>
4.1 Test Setup Diagram .....	74
<b>5 ACCREDITATION, DISCLAIMERS AND COPYRIGHT .....</b>	<b>76</b>
5.1 Accreditation, Disclaimers And Copyright .....	77



## **SECTION 1**

### **REPORT SUMMARY**

Radio Testing of the  
ViaSat, Inc.  
L-Band Satellite Fixed Terminal



## 1.1 INTRODUCTION

The information contained in this report is intended to show verification of the ViaSat, Inc. M2M FT2225 Terminal L-Band Satellite Fixed Terminal to the requirements of FCC Part 15 Subpart C §15.247 and IC RSS-247 Issue 1 May 2015.

Objective	To perform Radio Testing to determine the Equipment Under Test's (EUT's) compliance with the Test Specification, for the series of tests carried out.
Manufacturer	ViaSat, Inc.
Model Number(s)	FT2225
FCC ID Number	2ABLPFT2225
IC Number	20546-FT2225
Serial Number(s)	C10015220002
Number of Samples Tested	1
Test Specification/Issue/Date	<ul style="list-style-type: none"><li>• FCC Part 15 Subpart C §15.247 (October 1, 2014).</li><li>• RSS-247 - Licence-exempt Radio Apparatus (All Frequency Bands): Category I Equipment (Issue 1, May 2015).</li><li>• RSS-Gen - General Requirements for Compliance of Radio Apparatus (Issue 4, November 2014).</li><li>• Public Notice (DA 00-705 Released March 30, 2000) Filing and Measurement Guidelines for Frequency Hopping Spread Spectrum Systems.</li></ul>
Start of Test	July 17, 2015
Finish of Test	August 4, 2015
Name of Engineer(s)	Nikolay Shtin
Related Document(s)	None. Supporting documents for EUT certification are separate exhibits.



**1.2 BRIEF SUMMARY OF RESULTS**

A brief summary of the tests carried out in accordance with FCC Part 15 Subpart C §15.247 with cross-reference to the corresponding IC RSS standard is shown below.

Section	§15.247 Spec Clause	RSS	Test Description	Result	Comments/ Base Standard
2.1	§15.207 (a)	RSS-Gen 8.8	Conducted Emissions	N/A	
2.2	§15.247(a)(1)	RSS-247 Sec. 5.1(2)	Carrier Frequency Separation	Compliant	
2.3	§15.247(a)(1)(iii)	RSS-247 Sec. 5.1(4)	Number of Hopping Frequencies	Compliant	
2.4	§15.247(a)(1)(iii)	RSS-247 Sec. 5.1(4)	Time of Occupancy (Dwell Time)	Compliant	
2.5	§15.215(c)	RSS-247 Sec. 5.1(1)	20 dB Bandwidth	Compliant	
2.6		RSS-Gen 6.6	99% Emission Bandwidth	Compliant	
2.7	§15.247(b)(1)	RSS-247 Sec. 5.4(2)	Peak Output Power	Compliant	
2.8	§15.247(d)	RSS-247 Sec. 5.5	Band-edge Compliance of RF Conducted Emissions	Compliant	
2.9	§15.247(d)	RSS-247 Sec. 5.5	Spurious RF Conducted Emissions	Compliant	
2.10	§15.247(d)	RSS-247 Sec. 5.5	Spurious Radiated Emissions	Compliant	
2.11	§15.247(d)	RSS-247 Sec. 5.5	Radiated Immediate Restricted Bands	Compliant	
2.12		RSS-Gen 7.1	Receiver Spurious Emissions	Compliant	

*N/A EUT is a DC voltage operated device.*



### **1.3 PRODUCT INFORMATION**

#### **1.3.1 Technical Description**

The Equipment Under Test (EUT) is a ViaSat, Inc. M2M FT2225 Terminal (L-Band Satellite Fixed Terminal) model no. FT2225. The EUT is a device intended to provide dependable, instant IP-based machine-to-machine (M2M) communications via satellite. Powered by ViaSat Managed Services (VMS), this satcom terminal's secure two-way networking capability enables real-time data collections, monitoring and control for time-critical SCADA applications. The FT2225 incorporates Wi-Fi and Bluetooth functions. A shielded power/Ethernet CAT5e combine cable was provided and used by customer for final evaluation. The classic and EDR BT functions of the EUT were verified in this test report.





**1.3.2 EUT General Description**

EUT Description	L-Band Satellite Fixed Terminal
Model Name	M2M FT2225 Terminal
Model Number(s)	FT2225
Rated Voltage	10-32 VDC
Mode Verified	Bluetooth EDR (FHSS)
Capability	802.11 b/g WLAN and Bluetooth 3.0 + HS (w/out BLE)
Primary Unit (EUT)	<input type="checkbox"/> Production <input checked="" type="checkbox"/> Pre-Production <input type="checkbox"/> Engineering
Antenna Type	TDK Multilayer Chip Antenna for IEEE 802.11 a/b/g/n (P/N ANTO16008LCD2442MA1)
Antenna Gain	-6.23 dBi (2.412 GHz) -6.01 dBi (2.437 GHz) -4.79 dBi (2.472 GHz)

**1.3.3 Maximum Conducted Output Power**

Modulation	Frequency Range (MHz)	Average Output Power (dBm)	Peak Output Power (dBm)	Peak Output Power (mW)
GFSK	2402-2480	7.25	7.99	6.30
$\pi/4$ -DQPSK	2402-2480	5.06	7.83	6.07
8DPSK	2402-2480	5.06	8.20	6.61



**1.4 EUT TEST CONFIGURATION**

**1.4.1 Test Configuration Description**

Test Configuration	Description
A	Antenna conducted port test configuration. A conducted test sample was provided for this setup. The integral antenna was removed and an on-board surface mount coaxial connector was made accessible. EUT configuration was set to BT test mode via Ethernet connection using SSH/Telnet client application. Manufacturer provided the instructions for EUT configuration.
B	Radiated emissions test configuration. Identical programming procedure as Test Configuration A. EUT transmitting through the integral antenna.

**1.4.2 EUT Exercise Software**

EUT is configured via TCP/IP (Ethernet). EUT IP address is set to 192.168.100.2. This address is used to connect to the EUT via SSH/Telnet client application (PuTTY). Once connected, corresponding programming commands were issued in order to set the EUT in Bluetooth test mode. Afterwards the EUT has been connected to CMW500 wireless communications tester, which was used to control the EUT modulation, data rate and operational channel.

**1.4.3 Support Equipment and I/O cables**

Manufacturer	Equipment/Cable	Description
Sony	Laptop (PCG-31311L)	S/N 27545534 3006488
Sony	Laptop AC Adapter (ACDP-120E03)	S/N 592C60AYMSO26N
n/a	Ethernet EUT to Laptop	2.1 meters, shielded CAT5 cable w/ RJ-45 connectors

**1.4.4 Worst Case Configuration**

Worst-case configuration used in this test report as per maximum conducted output power measurements:

Modulation	Channel/Packet Type	Mode
GFSK	38 (Mid Channel)	Non-hopping
GFSK	-	Hopping

For radiated measurements X, Y and Z orientations were verified. No major variation in emissions observed between the three (3) orientations. Verifications performed using "X" configuration.

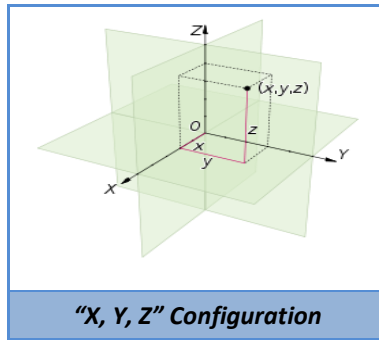

### 1.4.5 Simplified Test Configuration Diagram

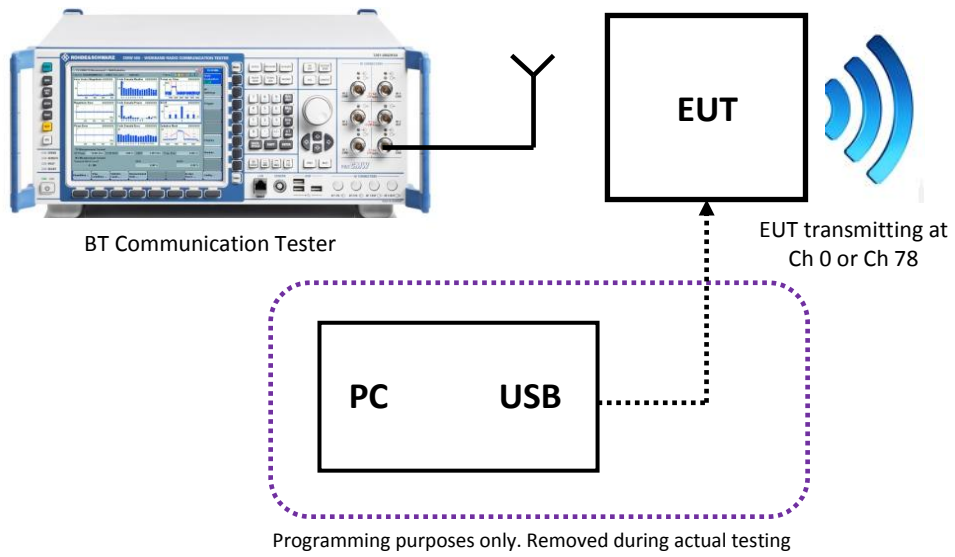

Test configuration used for radiated emissions testing

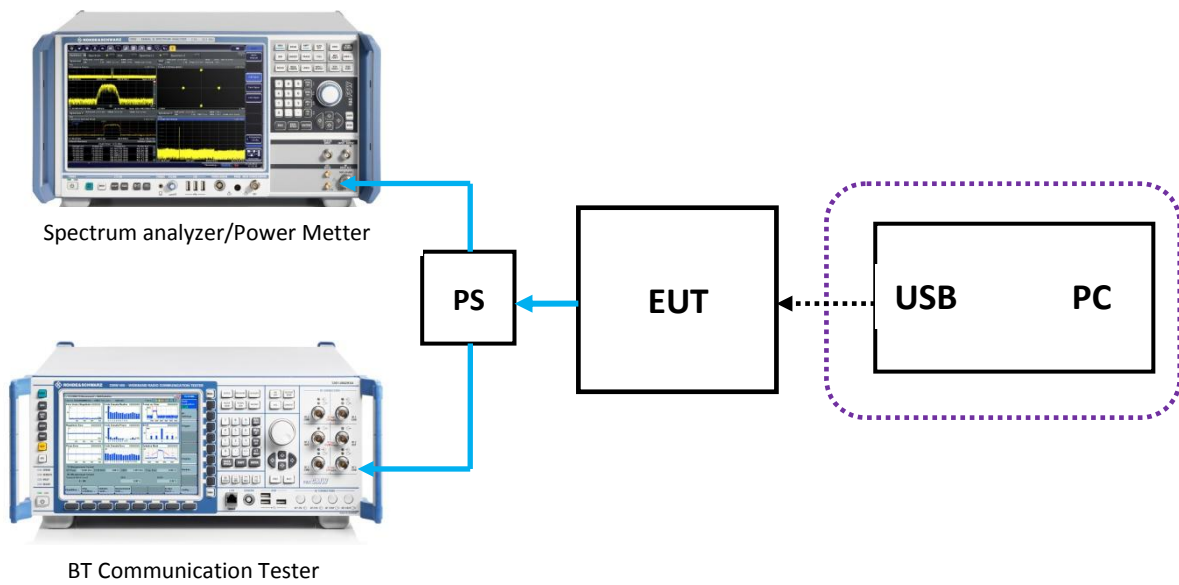

Test configuration used for conducted port emissions testing



**1.5 DEVIATIONS FROM THE STANDARD**

No deviations from the applicable test standards or test plan were made during testing.

**1.6 MODIFICATION RECORD**

Description of Modification	Modification Fitted By	Date Modification Fitted
Serial Number: C10015220002		
N/A	—	—

The table above details modifications made to the EUT during the test programme. The modifications incorporated during each test (if relevant) are recorded on the appropriate test pages.

**1.7 TEST METHODOLOGY**

All measurements contained in this report were conducted with ANSI C63.4-2009, American National Standard for Methods of Measurement of Radio-Noise Emissions from Low-Voltage Electrical and Electronic Equipment in the range of 9 kHz to 40 GHz.

For conducted and radiated emissions the equipment under test (EUT) was configured to measure its highest possible emission level. This level was based on the maximized cable configuration from exploratory testing per ANSI C63.4-2009. The test modes were adapted according to the Operating Instructions provided by the manufacturer/client.

**1.8 TEST FACILITY LOCATION**

**1.8.1 TÜV SÜD America Inc. (Mira Mesa)**

10040 Mesa Rim Road, San Diego, CA 92121-2912 (32.901268,-117.177681). Phone: 858 678 1400 FAX: 858-546 0364

**1.8.2 TÜV SÜD America Inc. (Rancho Bernardo)**

Sony Electronics Inc., Building #8 16530 Via Esprillo, San Diego, CA 92127-1708 (33.018644,-117.092409). Phone: 858 942 5542 FAX: 858-546 0364

**1.9 TEST FACILITY REGISTRATION**

**1.9.1 FCC – Registration No.: US1146**

TUV SUD America Inc. (San Diego), is an accredited test facility with the site description report on file and has met all the requirements specified in §2.948 of the FCC rules. The acceptance letter from the FCC is maintained in our files and the Registration is US1146.



**1.9.2 Industry Canada (IC) Registration No.: 3067A**

The 10m Semi-anechoic chamber of TÜV SÜD America Inc. (San Diego) has been registered by Certification and Engineering Bureau of Industry Canada for radio equipment testing with Registration No. 3067A.



## **SECTION 2**

### **TEST DETAILS**

Radio Testing of the  
ViaSat, Inc.  
L-Band Satellite Fixed Terminal



## **2.1 CARRIER FREQUENCY SEPARATION**

### **2.1.1 Specification Reference**

Part 15 Subpart C §15.247(a)(1)

### **2.1.2 Standard Applicable**

(1) Frequency hopping systems shall have hopping channel carrier frequencies separated by a minimum of 25 kHz or the 20 dB bandwidth of the hopping channel, whichever is greater. Alternatively, frequency hopping systems operating in the 2400–2483.5 MHz band may have hopping channel carrier frequencies that are separated by 25 kHz or two-thirds of the 20 dB bandwidth of the hopping channel, whichever is greater, provided the systems operate with an output power no greater than 125 mW. The system shall hop to channel frequencies that are selected at the system hopping rate from a pseudo randomly ordered list of hopping frequencies. Each frequency must be used equally on the average by each transmitter. The system receivers shall have input bandwidths that match the hopping channel bandwidths of their corresponding transmitters and shall shift frequencies in synchronization with the transmitted signals.

### **2.1.3 Equipment Under Test and Modification State**

Serial No: C10015220002 /Test Configuration B

### **2.1.4 Date of Test/Initial of test personnel who performed the test**

August 3, 2015/NS

### **2.1.5 Test Equipment Used**

The major items of test equipment used for the above tests are identified in Section 3.1.

### **2.1.6 Environmental Conditions**

Test performed at TÜV SÜD America Inc. Rancho Bernardo facility.

Ambient Temperature	24.8 °C
Relative Humidity	57.1 %
ATM Pressure	99.1 kPa

### **2.1.7 Additional Observations**

- Hopping function enabled.
- Span is wide enough to capture the peaks of two adjacent channels.
- RBW is 1% of the span.
- VBW is 3x RBW
- Sweep is auto
- Detector is peak.
- Trace is max hold.
- An offset of 6.9 dB was added to compensate the power splitter and coaxial cable attenuation.
- Marker-delta function is used between the peaks of the adjacent channels.
- Limit used is >946.67 kHz (2/3 of worst case 20dB BW).



**2.1.8 Test Results**

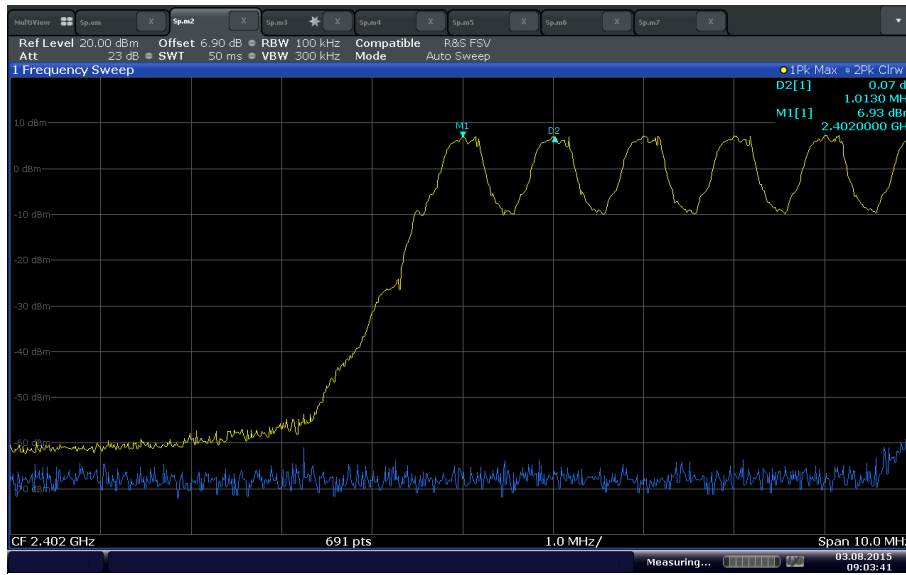

**GFSK**, observed carrier frequency separation between Ch0 and Ch1 is 1.013 MHz (**Complies**. Greater than 946.67 kHz, this is 2/3 of 1.42MHz 20 dB BW)

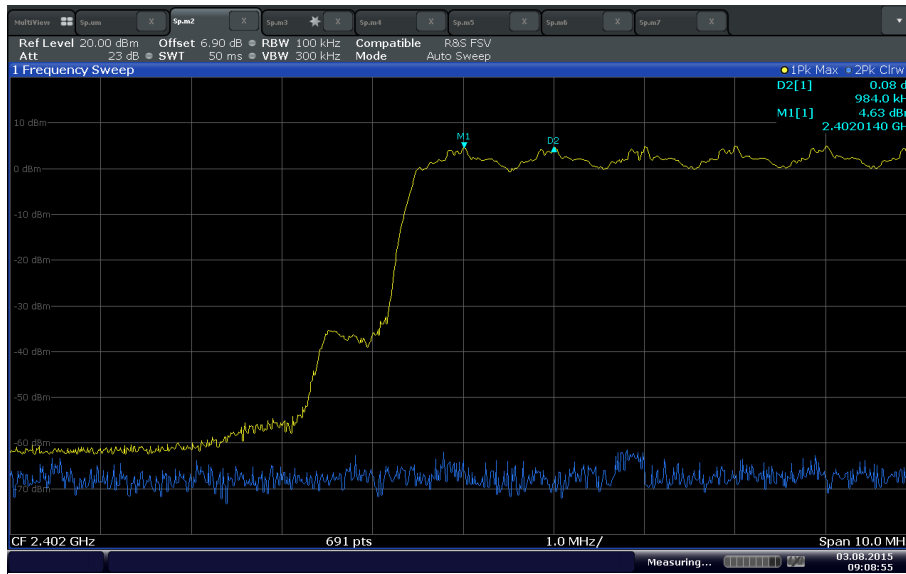

**$\pi/4$ -DQPSK**, observed carrier frequency separation between Ch0 and Ch1 is 0.984 MHz (**Complies**. Greater than 946.67 kHz, this is 2/3 of 1.42MHz 20 dB BW)

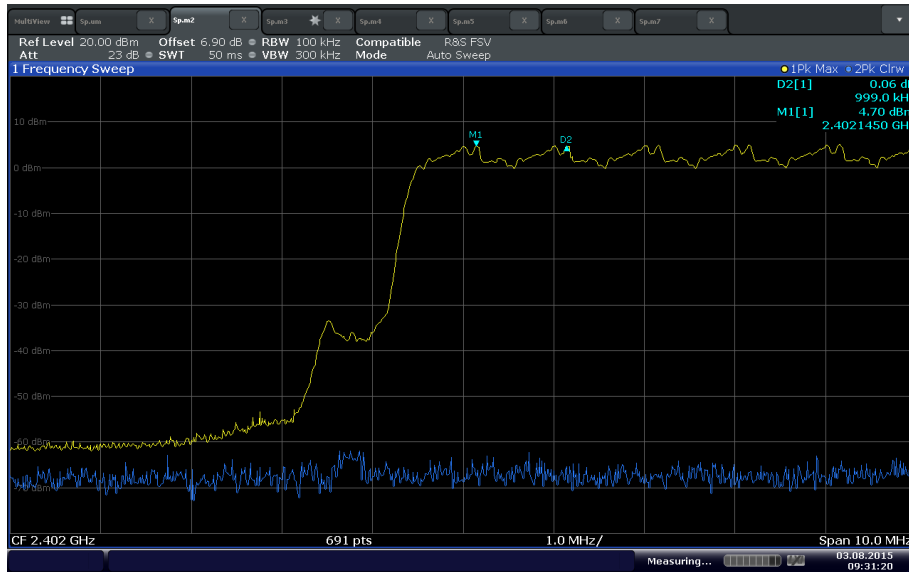

Date: 3 AUG 2015 09:31:20

**8DPSK**, observed carrier frequency separation between Ch0 and Ch1 is 0.999 MHz (**Complies**. Greater than 946.67 kHz, this is 2/3 of 1.42MHz 20 dB BW)



## 2.2 NUMBER OF HOPPING FREQUENCIES

### 2.2.1 Specification Reference

Part 15 Subpart C §15.247(a)(1)(iii)

### 2.2.2 Standard Applicable

(iii) Frequency hopping systems in the 2400–2483.5 MHz band shall use at least 15 channels. The average time of occupancy on any channel shall not be greater than 0.4 seconds within a period of 0.4 seconds multiplied by the number of hopping channels employed. Frequency hopping systems may avoid or suppress transmissions on a particular hopping frequency provided that a minimum of 15 channels are used.

### 2.2.3 Equipment Under Test and Modification State

Serial No: C10015220002 /Test Configuration B

### 2.2.4 Date of Test/Initial of test personnel who performed the test

August, 3/NS

### 2.2.5 Test Equipment Used

The major items of test equipment used for the above tests are identified in Section 3.1.

### 2.2.6 Environmental Conditions

Test performed at TÜV SÜD America Inc. Rancho Bernardo facility.

Ambient Temperature	24.8 °C
Relative Humidity	64.1 %
ATM Pressure	99.1 kPa

### 2.2.7 Additional Observations

- Hopping function enabled.
- Span is wide enough to capture the channels of interests.
- The span was broken up to two sections in order to clearly show all of the hopping frequencies.
- Sweep is auto
- Detector is peak, trace is max hold.
- An offset of 6.9dB was added to compensate for the external attenuator and cable used.

### 2.2.8 Test Results

Observed Number of Hopping Frequencies is = **79 (Complies)**  
= Plot #1 + Plot #2  
= 41 + 38

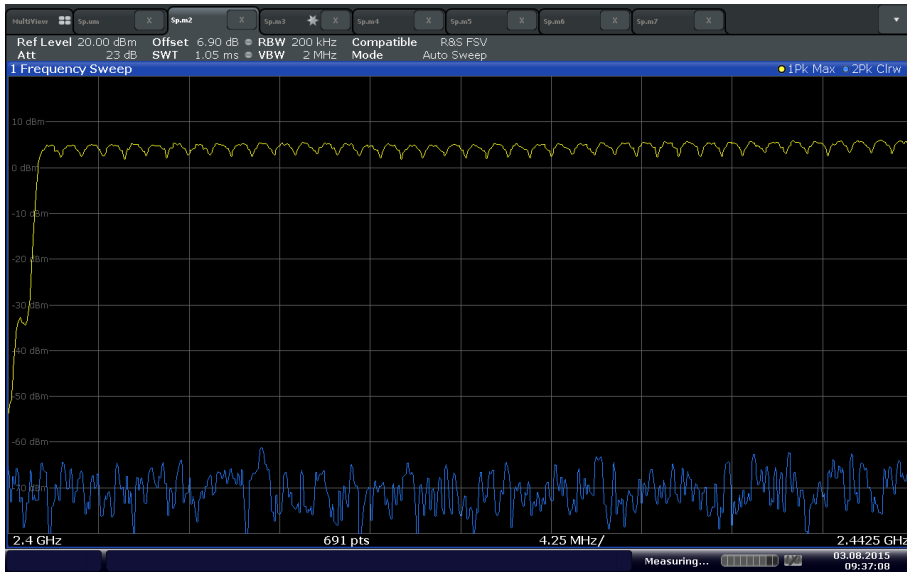

Date: 3 AUG 2015 09:37:08

Plot #1

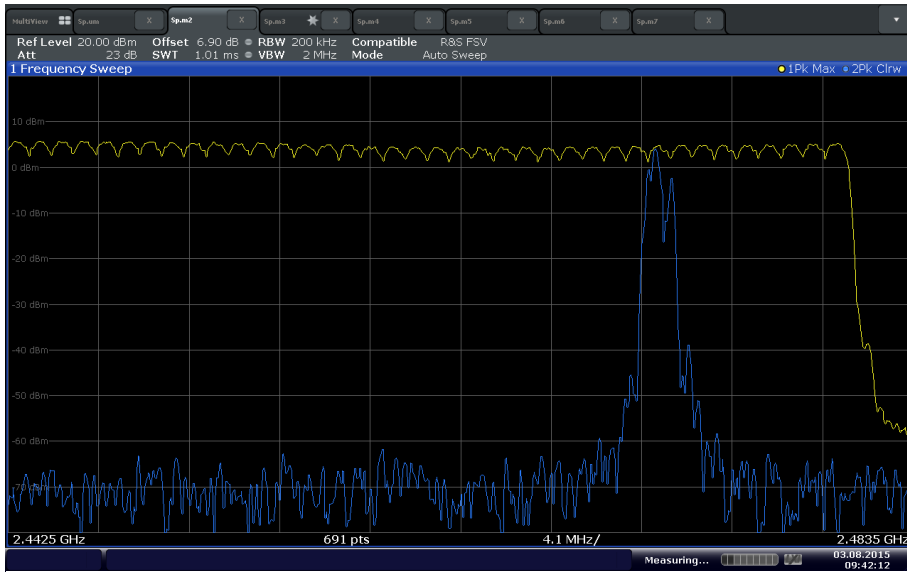

Date: 3 AUG 2015 09:42:12

Plot #2

## **2.3 TIME OF OCCUPANCY (DWELL TIME)**

### **2.3.1 Specification Reference**

Part 15 Subpart C §15.247(a)(1)(iii)

### **2.3.2 Standard Applicable**

(iii) Frequency hopping systems in the 2400–2483.5 MHz band shall use at least 15 channels. The average time of occupancy on any channel shall not be greater than 0.4 seconds within a period of 0.4 seconds multiplied by the number of hopping channels employed. Frequency hopping systems may avoid or suppress transmissions on a particular hopping frequency provided that a minimum of 15 channels are used.

### **2.3.3 Equipment Under Test and Modification State**

Serial No: C10015220002 /Test Configuration B

### **2.3.4 Date of Test/Initial of test personnel who performed the test**

August 3, 2015/NS

### **2.3.5 Test Equipment Used**

The major items of test equipment used for the above tests are identified in Section 3.1.

### **2.3.6 Environmental Conditions**

Test performed at TÜV SÜD America Inc. Rancho Bernardo facility.

Ambient Temperature	24.8 °C
Relative Humidity	64.1 %
ATM Pressure	99.1 kPa

### **2.3.7 Additional Observations**

- Hopping function enabled.
- Span = zero span, centered on a hopping channel.
- RBW is 1MHz.
- VBW is 3x RBW
- Detector is peak.
- A single pulse is first measured. This measurement is then used to compute the average time of occupancy in the required period (no. of channels x 0.4 second).
- The EUT was configured using the instructions provided by the manufacturer. Modulation type was PRBS9, logical channel were between ACL EDR and ACL Basic, packet type used were DH1, 2DH3 and 3DH1. Packet length was set to default value of 1000.

**2.3.8 Test Results**

Modulation	Measured time of occupancy	Requirement
GFSK	122.44 ms	<400 ms
$\pi/4$ -DQPSK	262.49 ms	<400 ms
8DPSK	123.36 ms	<400 ms

**2.3.9 Sample Computation (8DPSK)**

Width of single pulse = 0.0003855 second  
 Observed occurrence = 32 pulses/3.16 seconds  
 Required period = 79 channels x 0.4 second  
 = 31.6 seconds

Average time of occupancy = Pulse width x #pulses in 3.16 seconds x 10  
 = 0.0003855 second x 32x 10  
 = 0.12336 second

Compliance = Complies. 0.12336 second < 0.4 second

**2.3.10 Test Results Plots**

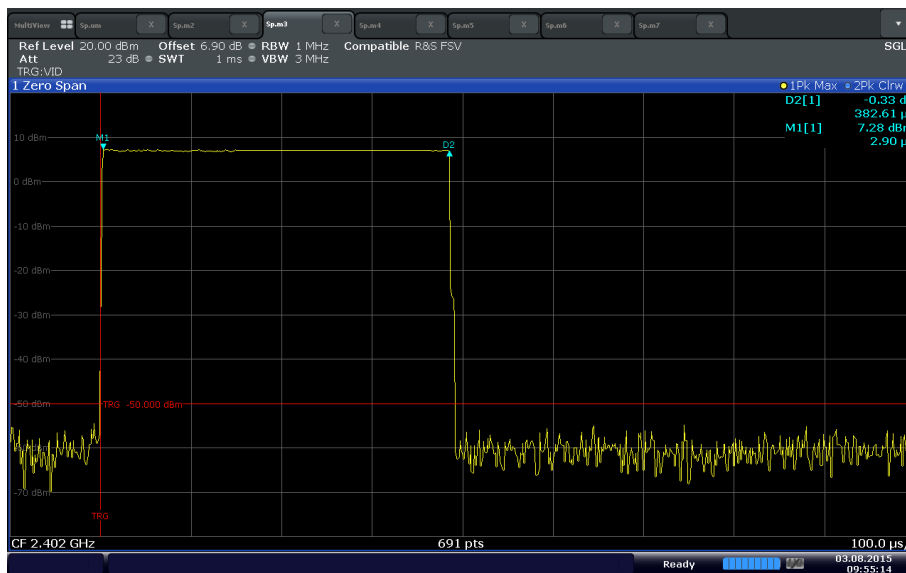

Date: 3.AUG.2015 09:55:15

**GFSK width of single pulse (0.38261ms)**

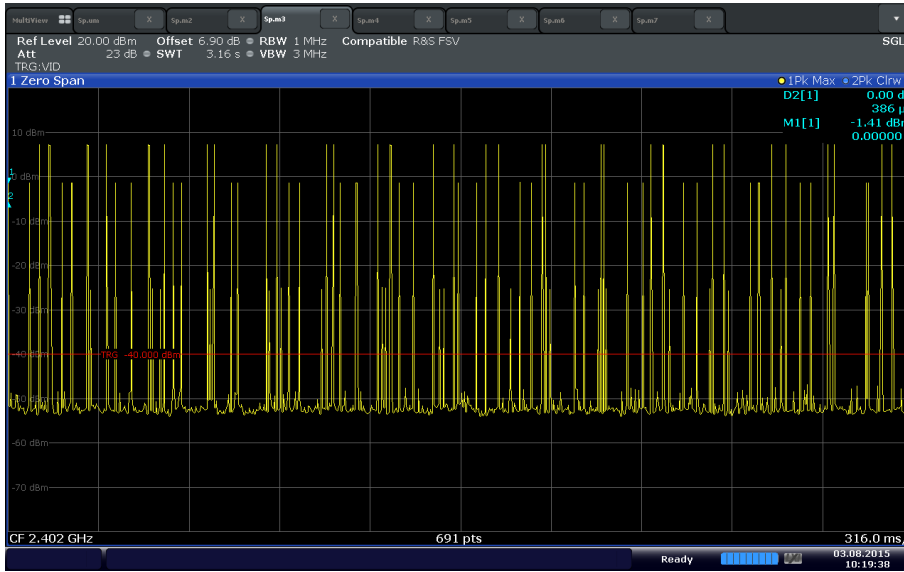

Date: 3.AUG.2015 10:19:38

**32 pulses/3.16 seconds (DH1)**

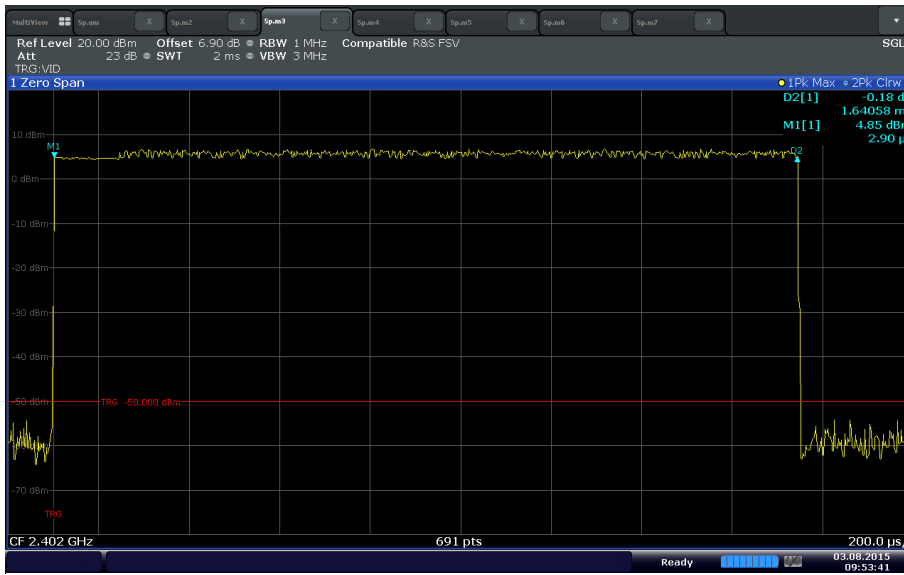

Date: 3.AUG.2015 09:53:41

**$\pi/4$ -DQPSK width of single pulse (1.64058 ms)**

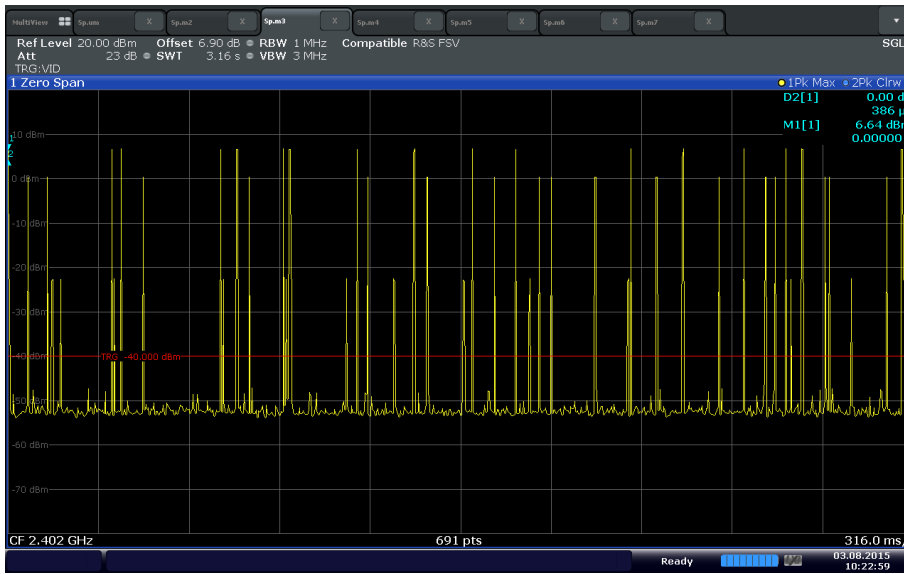

Date: 3.AUG.2015 10:22:59

16 pulses/3.16 seconds ( $\pi/4$ -DQPSK, 2 DH3)

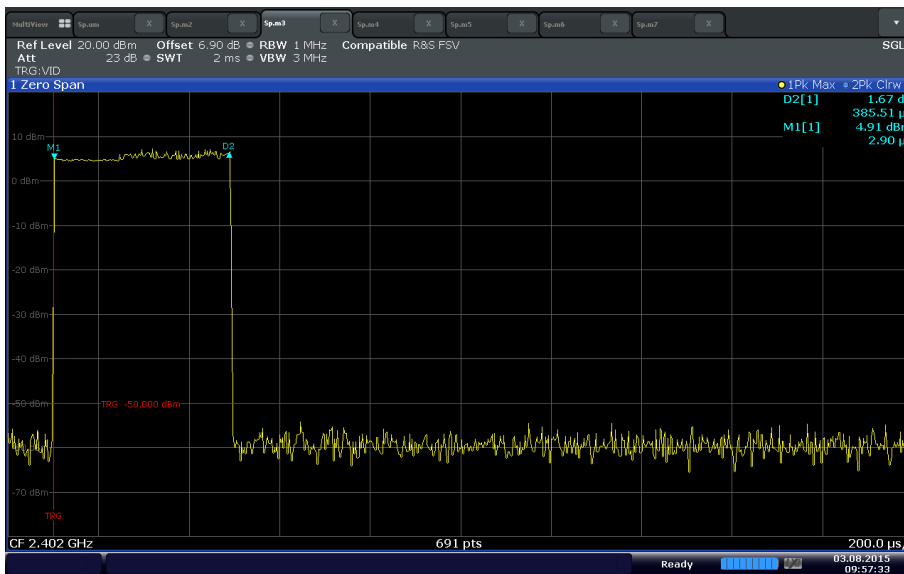

Date: 3.AUG.2015 09:57:34

8DPSK width of single pulse (0.38551 ms)



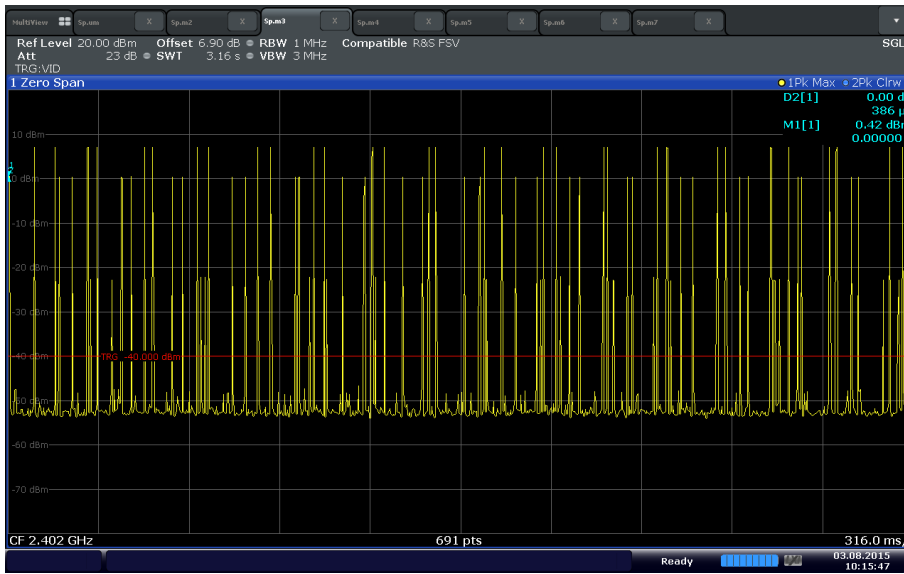

Date: 3.AUG 2015 10:15:48

**32 pulses/3.16 seconds (8DPSK, 3 DH1)**



## **2.4 20 dB BANDWIDTH**

### **2.4.1 Specification Reference**

Part 15 Subpart C §15.215(c)

### **2.4.2 Standard Applicable**

(c) Intentional radiators operating under the alternative provisions to the general emission limits, as contained in §§15.217 through 15.257 and in Subpart E of this part, must be designed to ensure that the 20 dB bandwidth of the emission, or whatever bandwidth may otherwise be specified in the specific rule section under which the equipment operates, is contained within the frequency band designated in the rule section under which the equipment is operated. The requirement to contain the designated bandwidth of the emission within the specified frequency band includes the effects from frequency sweeping, frequency hopping and other modulation techniques that may be employed as well as the frequency stability of the transmitter over expected variations in temperature and supply voltage. If a frequency stability is not specified in the regulations, it is recommended that the fundamental emission be kept within at least the central 80% of the permitted band in order to minimize the possibility of out-of-band operation.

### **2.4.3 Equipment Under Test and Modification State**

Serial No: C10015220002 /Test Configuration B

### **2.4.4 Date of Test/Initial of test personnel who performed the test**

July 23, 2015/NS

### **2.4.5 Test Equipment Used**

The major items of test equipment used for the above tests are identified in Section 3.1.

### **2.4.6 Environmental Conditions**

Test performed at TÜV SÜD America Inc. Rancho Bernardo facility.

Ambient Temperature	24.8 °C
Relative Humidity	64.1 %
ATM Pressure	99.1 kPa

### **2.4.7 Additional Observations**

- This is a conducted test.
- An offset of 6.9 dB was added to compensate the power splitter and coaxial cable attenuation.
- Span is approximately 2 to 3 times the expected 20dB bandwidth.
- RBW is  $\geq 1\%$  of the expected 20dB bandwidth while VBW is  $\geq$  RBW.
- Sweep is auto.
- Detector is peak.
- Max hold function activated.



- “n dB down” marker function (20dB) of the spectrum analyzer was used for this test.

**2.4.8 Test Results**

Modulation	Channel	Frequency (MHz)	Measured 20dB Bandwidth (MHz)
GFSK	0	2402	1.13
	38	2440	1.13
	78	2480	1.13
$\pi/4$ -DQPSK	0	2402	1.42
	38	2440	1.42
	78	2480	1.42
8DPSK	0	2402	1.41
	38	2440	1.41
	78	2480	1.41

**Worst case configuration ( $\pi/4$ -DQPSK)**

2402 MHz – (20dB BW/2) = 2401.29 MHz (within the frequency band - **Compliant**)

**Worst case configuration ( $\pi/4$ -DQPSK)**

2480 MHz + (20dB BW/2) = 2480.71 MHz (within the frequency band - **Compliant**)

**2.4.9 Test Results Plots**

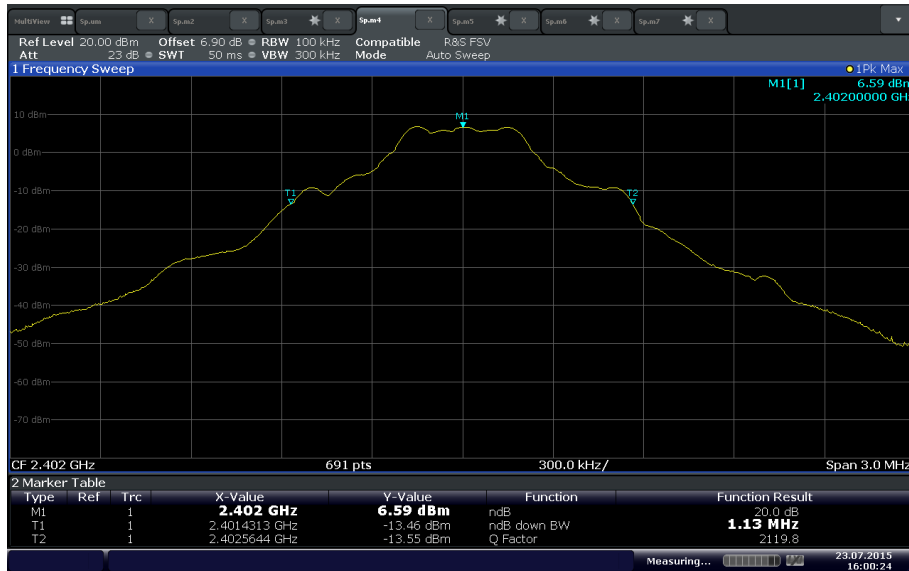

Date: 23 JUL 2015 16:00:24

**GFSK Low Channel**



Date: 23 JUL 2015 16:24:38

### GFSK Mid Channel

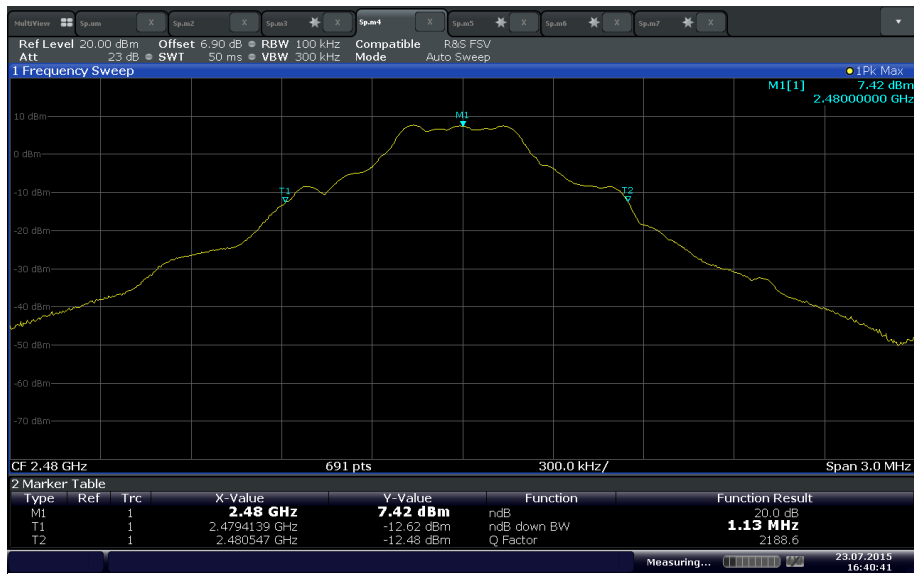

Date: 23 JUL 2015 16:40:41

### GFSK High Channel

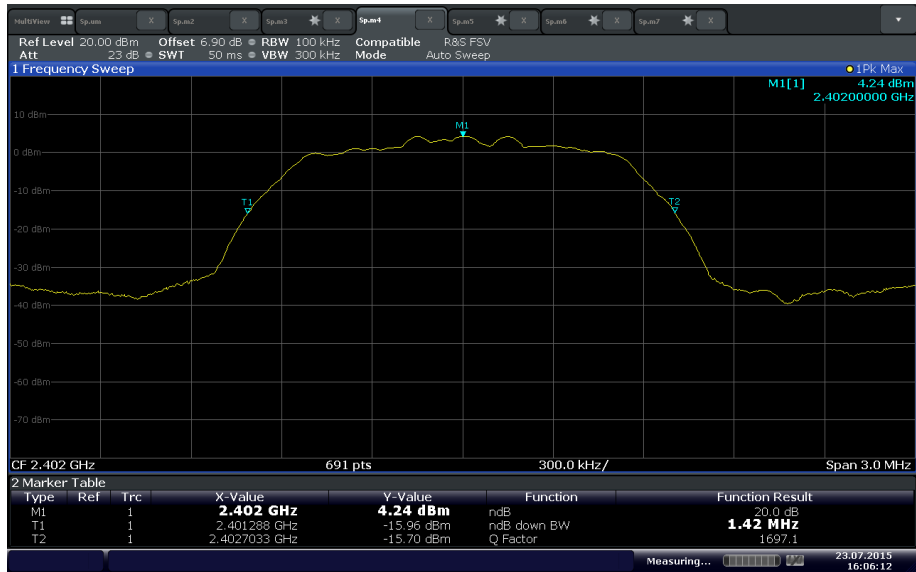

Date: 23 JUL 2015 16:06:12

$\pi/4$ -DQPSK Low Channel

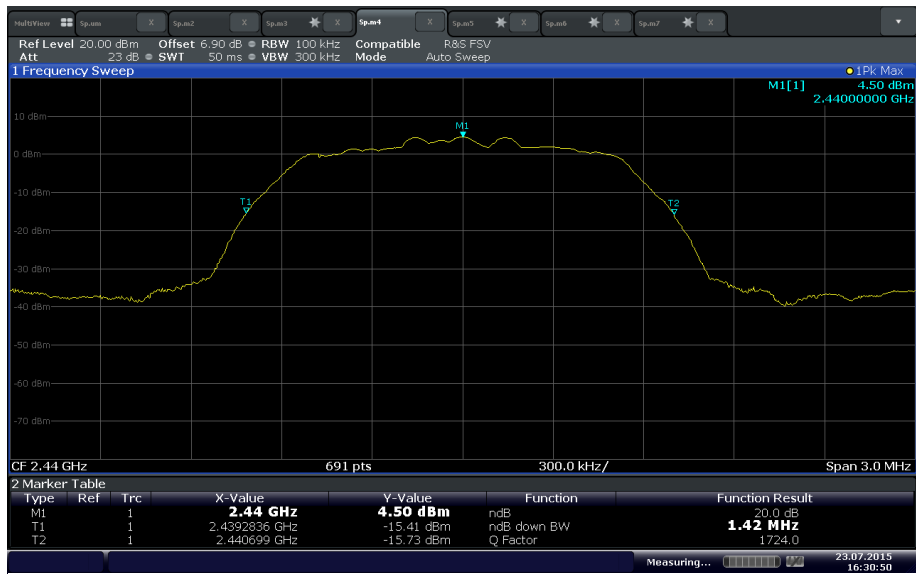

Date: 23 JUL 2015 16:30:51

$\pi/4$ -DQPSK Mid Channel

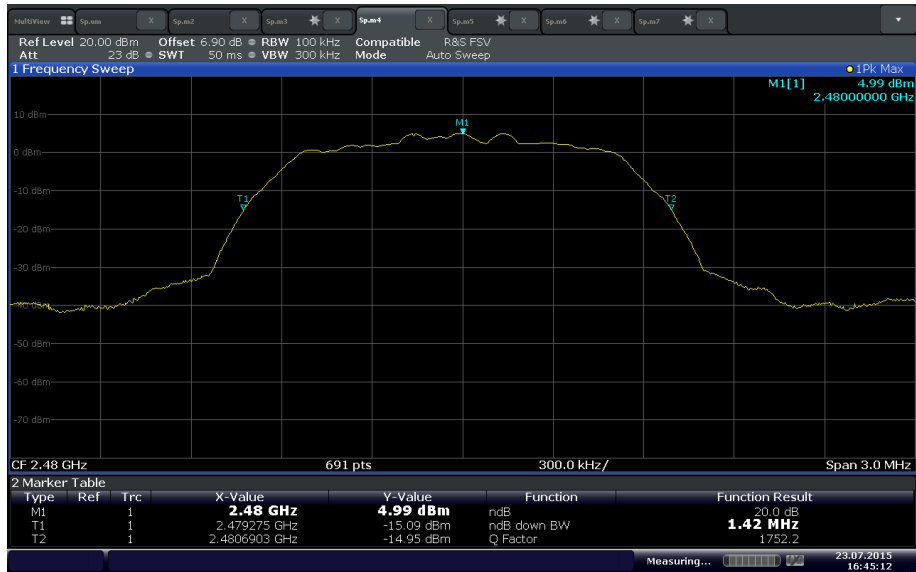

Date: 23 JUL 2015 16:45:13

**π/4-DQPSK High Channel**

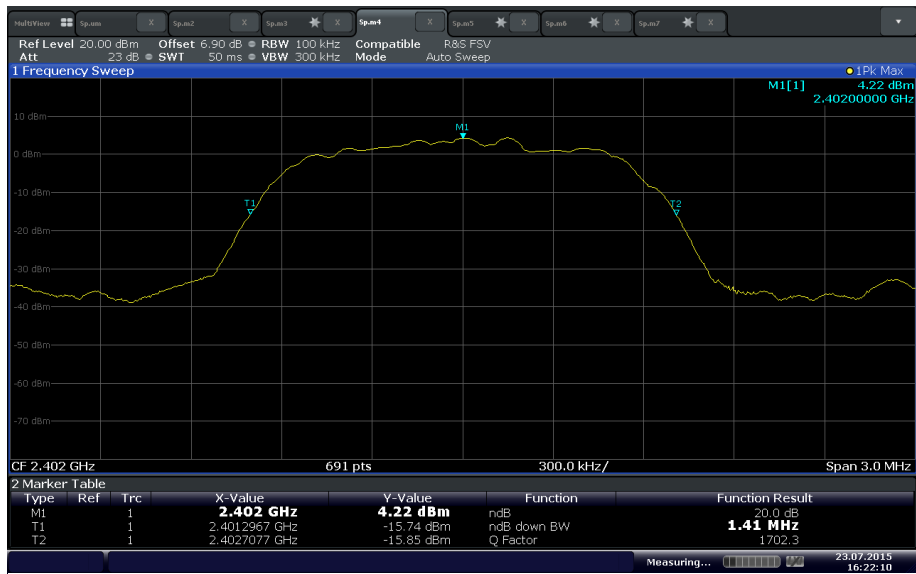

Date: 23 JUL 2015 16:22:11

**8DPSK Low Channel**

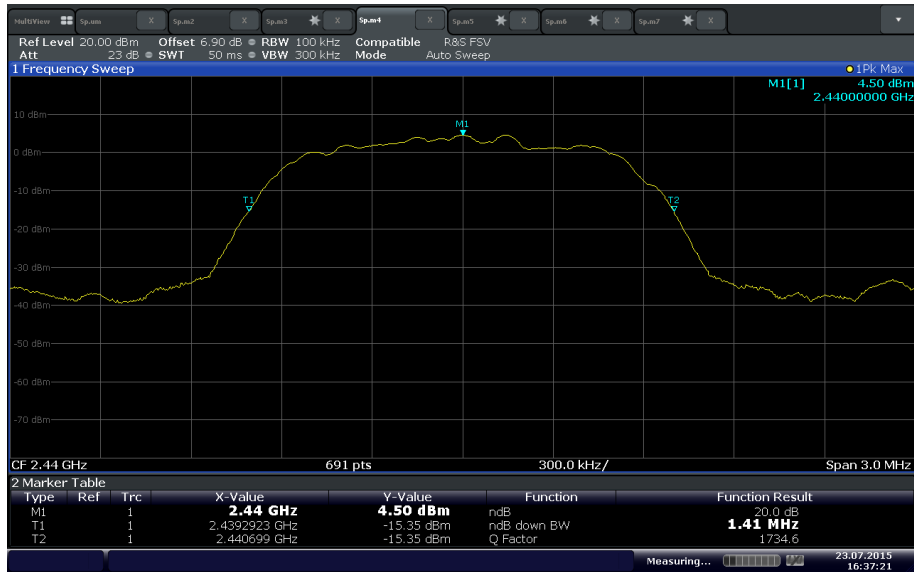

Date: 23 JUL 2015 16:37:21

### 8DPSK Mid Channel

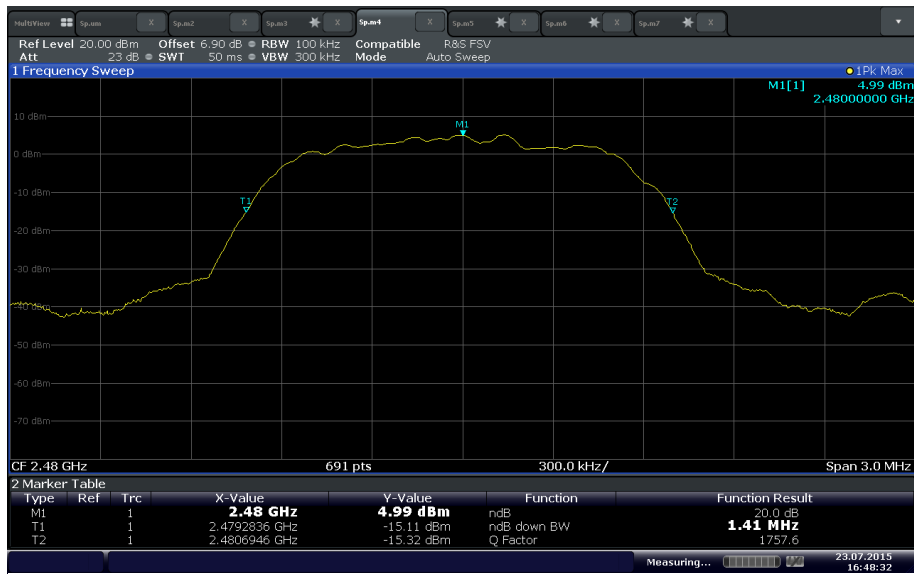

Date: 23 JUL 2015 16:48:33

### 8DPSK High Channel

## **2.5 99% EMISSION BANDWIDTH**

### **2.5.1 Specification Reference**

RSS-Gen Clause 6.6

### **2.5.2 Standard Applicable**

The emission bandwidth (x dB) is defined as the frequency range between two points, one above and one below the carrier frequency, at which the spectral density of the emission is attenuated x dB below the maximum in-band spectral density of the modulated signal. Spectral density (power per unit bandwidth) is to be measured with a detector of resolution bandwidth in the range of 1% to 5% of the anticipated emission bandwidth, and a video bandwidth at least 3x the resolution bandwidth.

When the occupied bandwidth limit is not stated in the applicable RSS or reference measurement method, the transmitted signal bandwidth shall be reported as the 99% emission bandwidth, as calculated or measured.

- The transmitter shall be operated at its maximum carrier power measured under normal test conditions.
- • The span of the analyzer shall be set to capture all products of the modulation process, including the emission skirts.
- • The resolution bandwidth (RBW) shall be in the range of 1% to 5% of the occupied bandwidth (OBW) and video bandwidth (VBW) shall be approximately 3x RBW.

Note: Video averaging is not permitted.

A peak, or peak hold, may be used in place of the sampling detector as this may produce a wider bandwidth than the actual bandwidth (worst-case measurement). Use of a peak hold may be necessary to determine the occupied bandwidth if the device is not transmitting continuously.

The trace data points are recovered and are directly summed in linear power level terms. The recovered amplitude data points, beginning at the lowest frequency, are placed in a running sum until 0.5% of the total is reached and that frequency recorded. The process is repeated for the highest frequency data points (starting at the highest frequency, at the right side of the span, and going down in frequency). This frequency is then recorded.

The difference between the two recorded frequencies is the 99% occupied bandwidth.

### **2.5.3 Equipment Under Test and Modification State**

Serial No: C10015220002 /Test Configuration B

### **2.5.4 Date of Test/Initial of test personnel who performed the test**

July 23, 2015/NS

### **2.5.5 Test Equipment Used**

The major items of test equipment used for the above tests are identified in Section 3.1.





**2.5.6 Environmental Conditions**

Test performed at TÜV SÜD America Inc. Rancho Bernardo facility.

Ambient Temperature 24.8 °C  
 Relative Humidity 64.1 %  
 ATM Pressure 99.1 kPa

**2.5.7 Additional Observations**

- This is a conducted test.
- An offset of 6.9 dB was added to compensate the power splitter and coaxial cable attenuation.
- Span is wide enough to capture the channel transmission.
- RBW is 1% of the span.
- VBW is 3X RBW.
- Sweep is auto.
- Detector is peak.
- The % Power Bandwidth setting in the spectrum analyzer was set to 99% (default).
- The OBW power measurement function of the spectrum analyzer was used for this test.

**2.5.8 Test Results (For reporting purposes only)**

Modulation	Channel	Frequency (MHz)	Measured 20dB Bandwidth (MHz)
GFSK	0	2402	0.998
	38	2440	1.013
	78	2480	0.998
$\pi/4$ -DQPSK	0	2402	1.230
	38	2440	1.216
	78	2480	1.230
8DPSK	0	2402	1.230
	38	2440	1.216
	78	2480	1.230



2.5.9 Test Results Plots

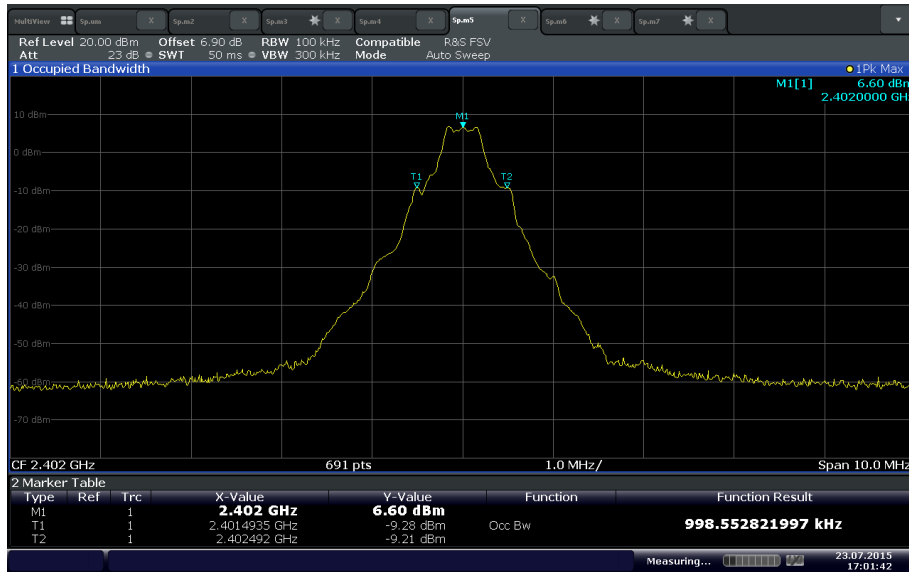

Date: 23 JUL 2015 17:01:42

GFSK Low Channel

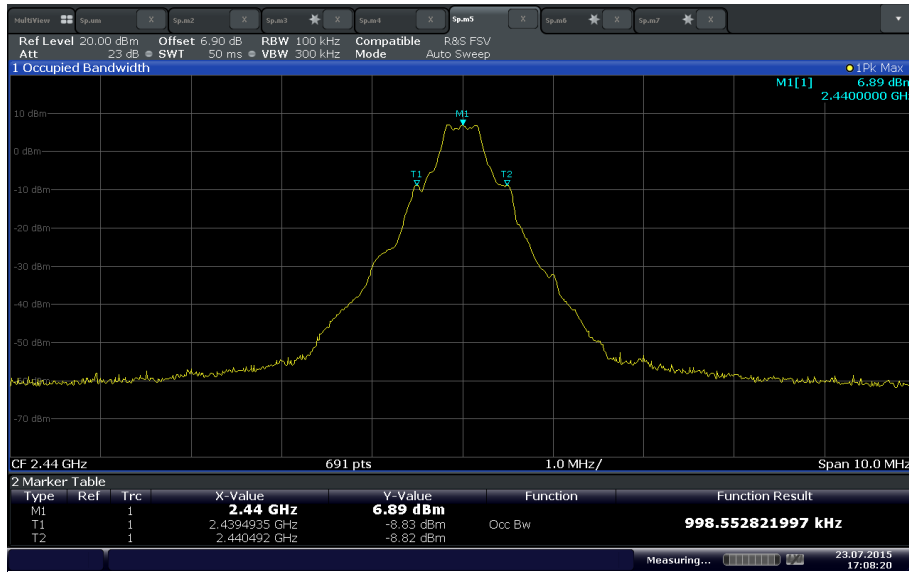

Date: 23 JUL 2015 17:08:20

GFSK Mid Channel

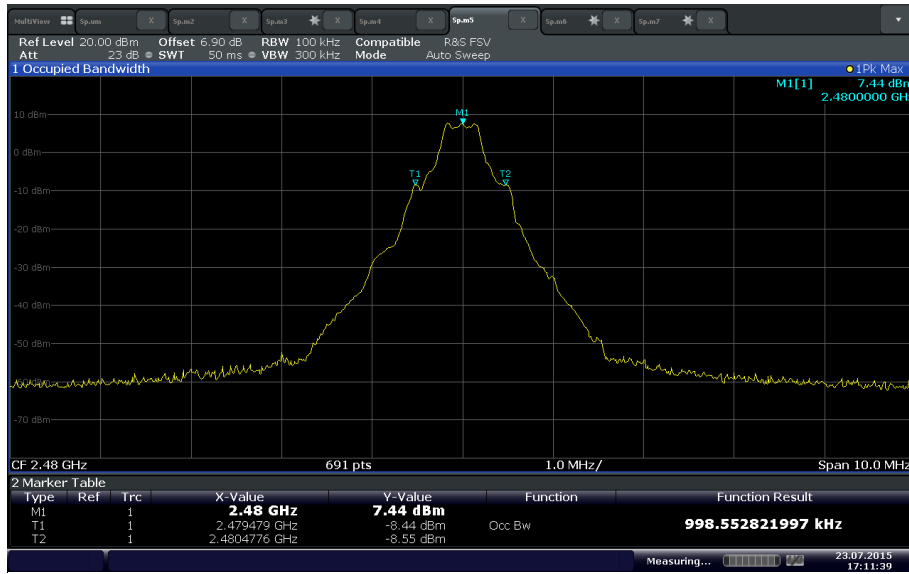

Date: 23 JUL 2015 17:11:39

**GFSK High Channel**

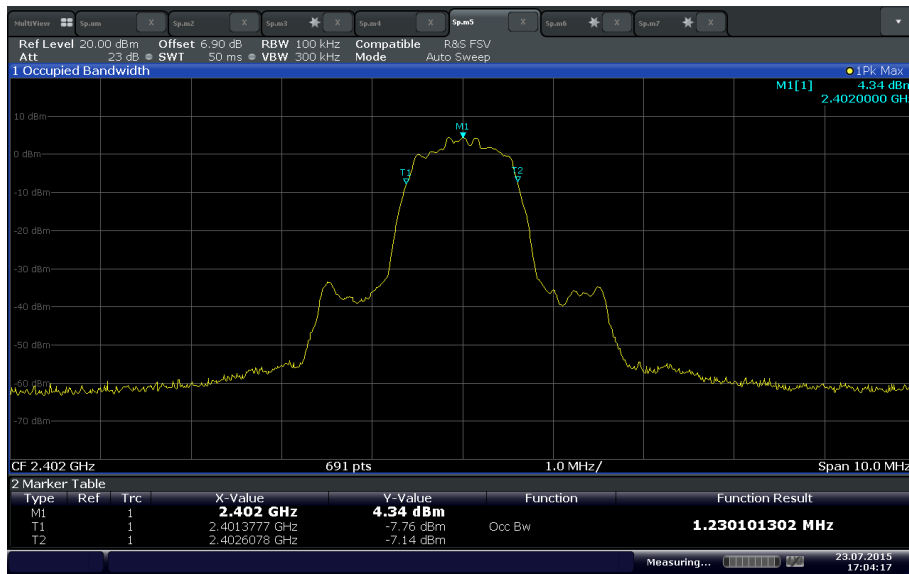

Date: 23 JUL 2015 17:04:17

**$\pi/4$ -DQPSK Low Channel**

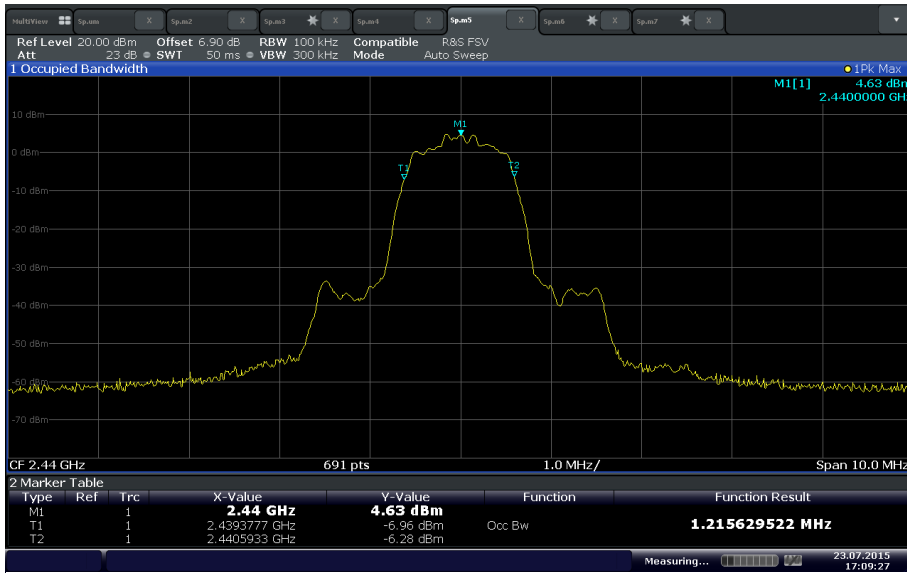

Date: 23.JUL.2015 17:09:28

$\pi/4$ -DQPSK Mid Channel

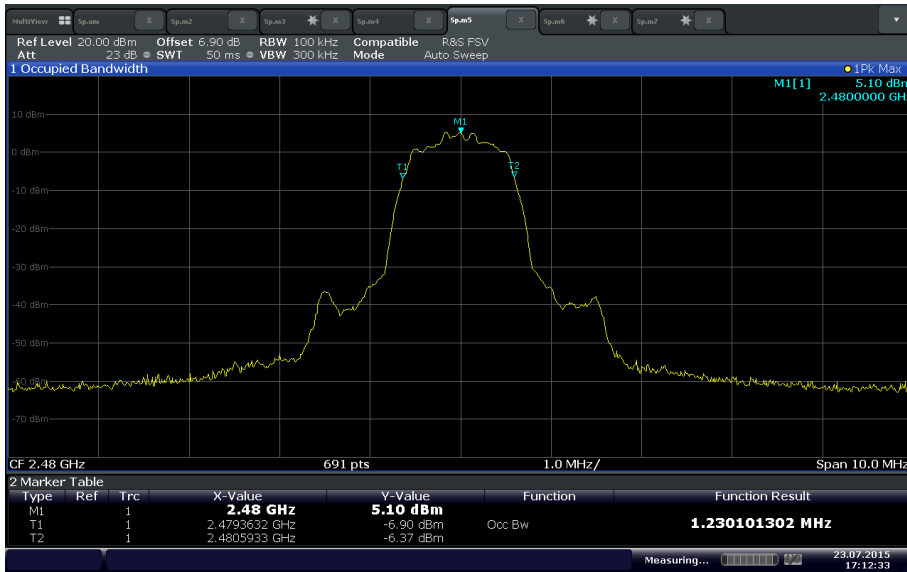

Date: 23.JUL.2015 17:12:33

$\pi/4$ -DQPSK High Channel

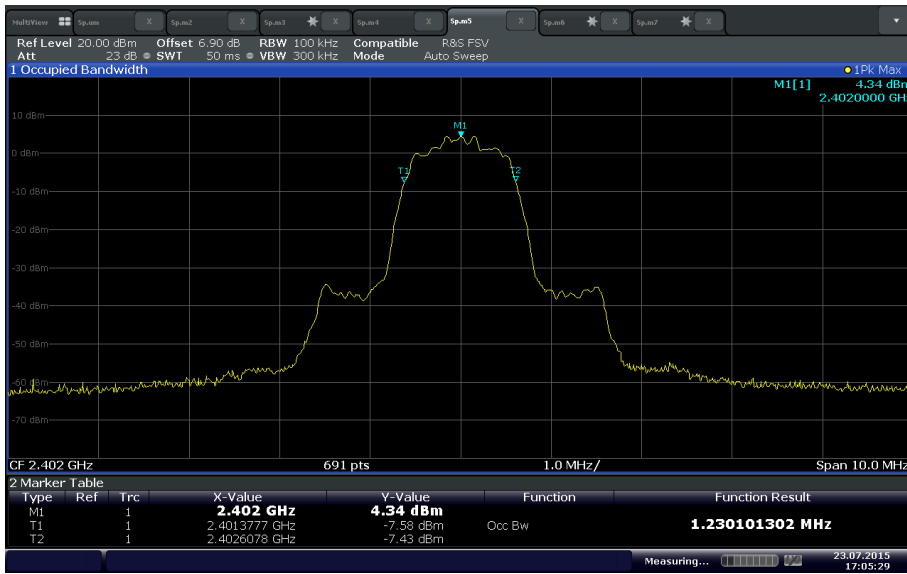

Date: 23 JUL 2015 17:05:29

**8DPSK Low Channel**

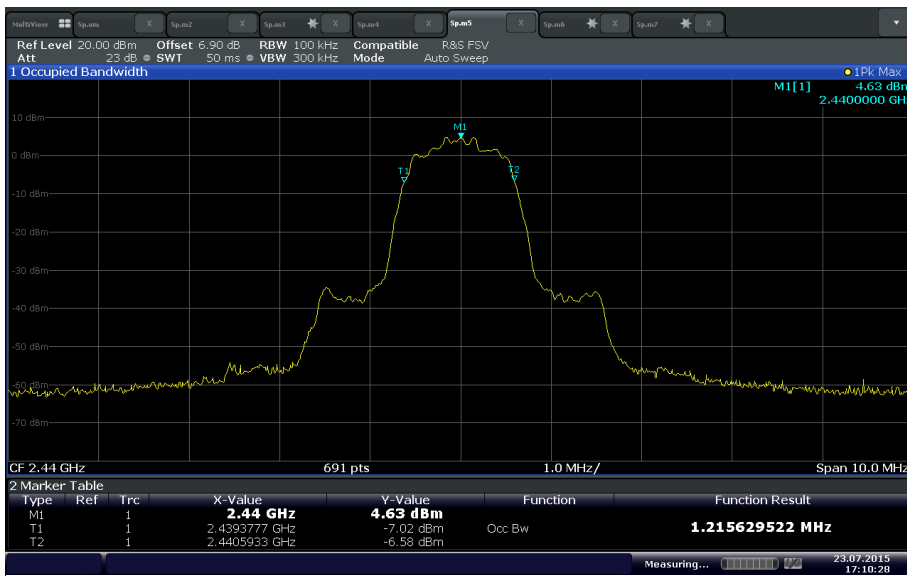

Date: 23 JUL 2015 17:10:28

**8DPSK Mid Channel**

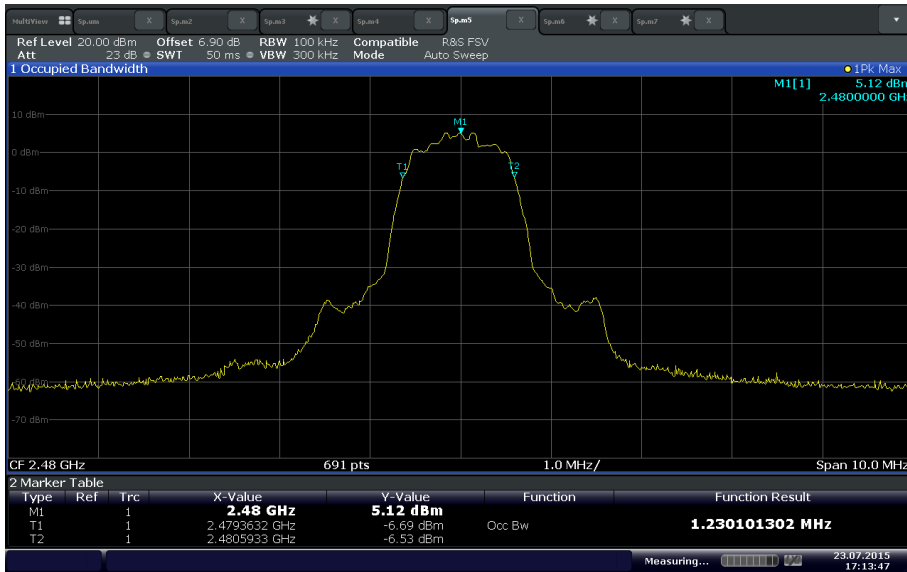

Date: 23 JUL 2015 17:13:47

**8DPSK High Channel**



**2.6 PEAK OUTPUT POWER**

**2.6.1 Specification Reference**

Part 15 Subpart C §15.247(b)(1)

**2.6.2 Standard Applicable**

(1) For frequency hopping systems operating in the 2400–2483.5 MHz band employing at least 75 non-overlapping hopping channels, and all frequency hopping systems in the 5725–5850 MHz band: 1 watt. For all other frequency hopping systems in the 2400–2483.5 MHz band: 0.125 watts.

**2.6.3 Equipment Under Test and Modification State**

Serial No: C10015220002 /Test Configuration B

**2.6.4 Date of Test/Initial of test personnel who performed the test**

July 16, 2015/NS

**2.6.5 Test Equipment Used**

The major items of test equipment used for the above tests are identified in Section 3.1.

**2.6.6 Environmental Conditions**

Test performed at TÜV SÜD America Inc. Rancho Bernardo facility.

Ambient Temperature	24.8 °C
Relative Humidity	64.1 %
ATM Pressure	99.1 kPa

**2.6.7 Additional Observations**

This is a conducted test using a Peak Power Meter.

**2.6.8 Test Results (Conducted)**

Modulation	Channel	Frequency (MHz)	Measured Average Output Power (dBm)	Measured Peak Output Power (dBm)	Measured Peak Output Power (mW)	Limit (mW)
GFSK	0	2402	6.60	7.26	5.32	1000.0
	38	2440	<b>7.25</b>	7.99	6.30	1000.0
	78	2480	7.11	7.86	6.11	1000.0
$\pi/4$ -DQPSK	0	2402	4.46	7.19	5.24	1000.0
	38	2440	5.06	7.76	5.97	1000.0
	78	2480	4.89	7.68	5.86	1000.0
8DPSK	0	2402	4.46	7.65	5.82	1000.0
	38	2440	5.06	8.20	6.61	1000.0
	78	2480	4.90	8.14	6.52	1000.0

**2.6.9 Test Results (De Facto EIRP Limit)**

Modulation	Channel	Frequency (MHz)	Measured Peak Output Power (dBm)	Antenna Gain (dBi)	Calculated Peak Output Power EIRP (dBm)	Limit (dBm)
GFSK	38	2440	7.99	-6.01	1.98	30
$\pi/4$ -DQPSK	38	2440	7.76	-6.01	1.75	30
8DPSK	38	2440	8.20	-6.01	2.19	30

**2.6.10 Sample Test Display**

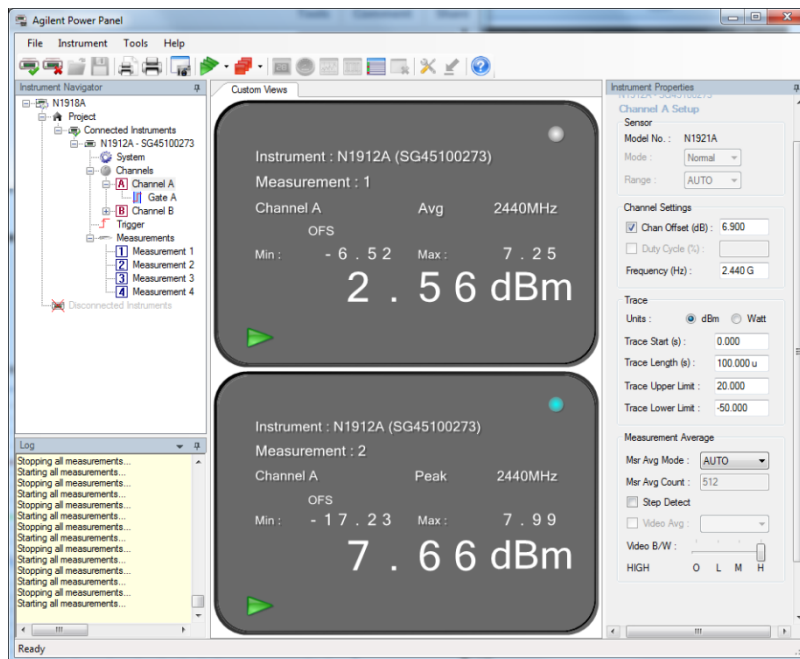

**GFSK mid channel (Channel 38 2440 MHz)**



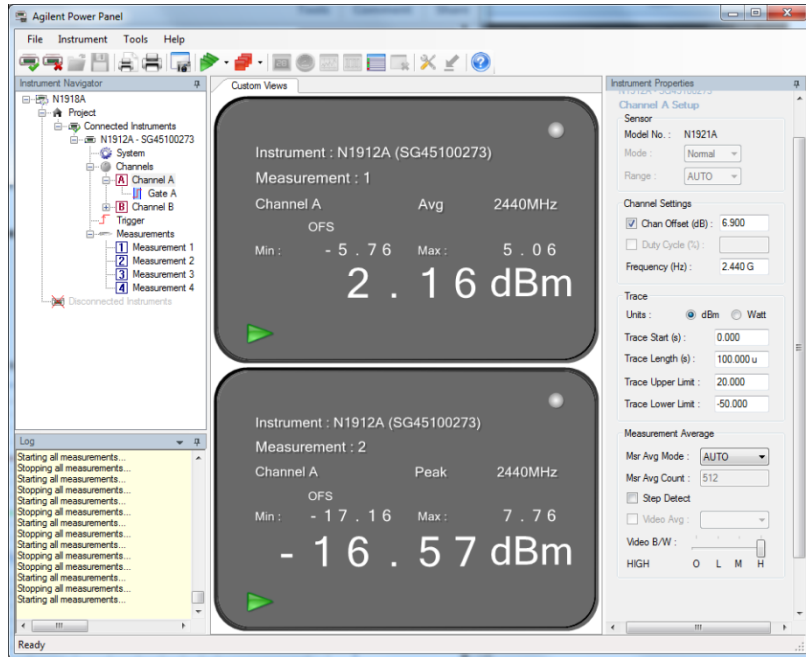

**$\pi/4$ -DQPSK mid channel (Channel 38 2440 MHz)**

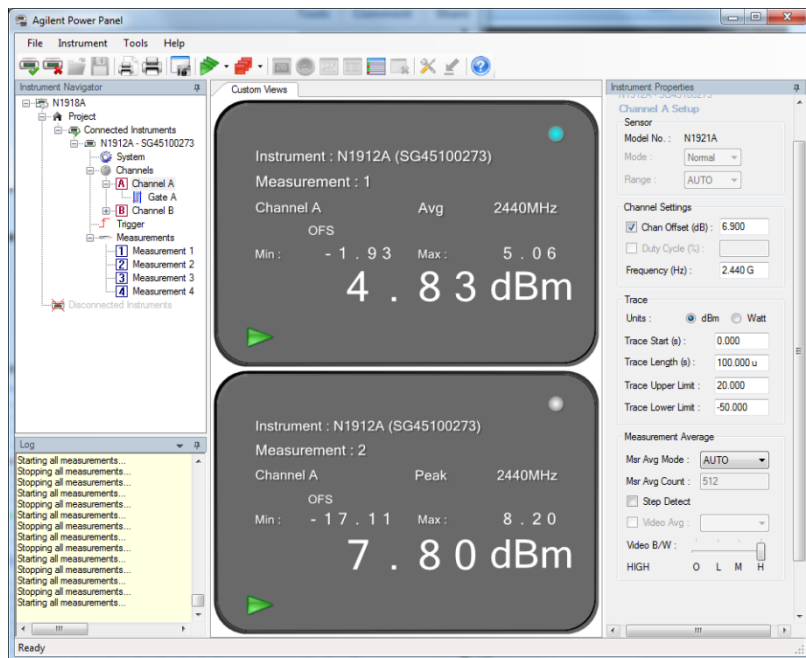

**8DPSK mid channel (Channel 38 2440 MHz)**

## **2.7 BAND-EDGE COMPLIANCE OF RF CONDUCTED EMISSIONS**

### **2.7.1 Specification Reference**

Part 15 Subpart C §15.247(d)

### **2.7.2 Standard Applicable**

(d) In any 100 kHz bandwidth outside the frequency band in which the spread spectrum or digitally modulated intentional radiator is operating, the radio frequency power that is produced by the intentional radiator shall be at least 20 dB below that in the 100 kHz bandwidth within the band that contains the highest level of the desired power, based on either an RF conducted or a radiated measurement, provided the transmitter demonstrates compliance with the peak conducted power limits. If the transmitter complies with the conducted power limits based on the use of RMS averaging over a time interval, as permitted under paragraph (b)(3) of this section, the attenuation required under this paragraph shall be 30 dB instead of 20 dB. Attenuation below the general limits specified in §15.209(a) is not required. In addition, radiated emissions which fall in the restricted bands, as defined in §15.205(a), must also comply with the radiated emission limits specified in §15.209(a) (see §15.205(c)).

### **2.7.3 Equipment Under Test and Modification State**

Serial No: C10015220002 /Test Configuration B

### **2.7.4 Date of Test/Initial of test personnel who performed the test**

July 23, 2015/NS

### **2.7.5 Test Equipment Used**

The major items of test equipment used for the above tests are identified in Section 3.1.

### **2.7.6 Environmental Conditions**

Test performed at TÜV SÜD America Inc. Rancho Bernardo facility.

Ambient Temperature	24.8 °C
Relative Humidity	64.1 %
ATM Pressure	99.1 kPa

### **2.7.7 Additional Observations**

- This is a conducted test.
- An offset of 6.9 dB was added to compensate the power splitter and coaxial cable attenuation.
- Span is wide enough to capture the peak level of the emission operating on the channel closest to the band edge.
- RBW is  $\geq 1\%$  of the span, VBW is  $\geq$  RBW.
- Sweep is auto, detector is peak, trace is max hold.
- Trace allowed to stabilize. Marker-delta function used to verify compliance.
- Limit is 20dBc.
- Both Hopping and Non-Hopping mode verified.

### 2.7.8 Test Results

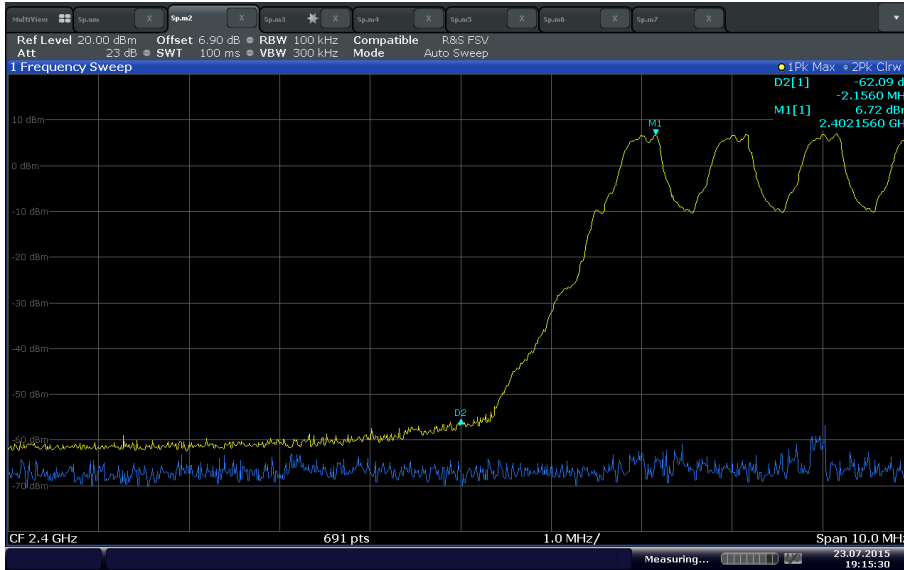

Date: 23\_JUL\_2015 19:15:30

Hopping lower bandedge (GFSK)

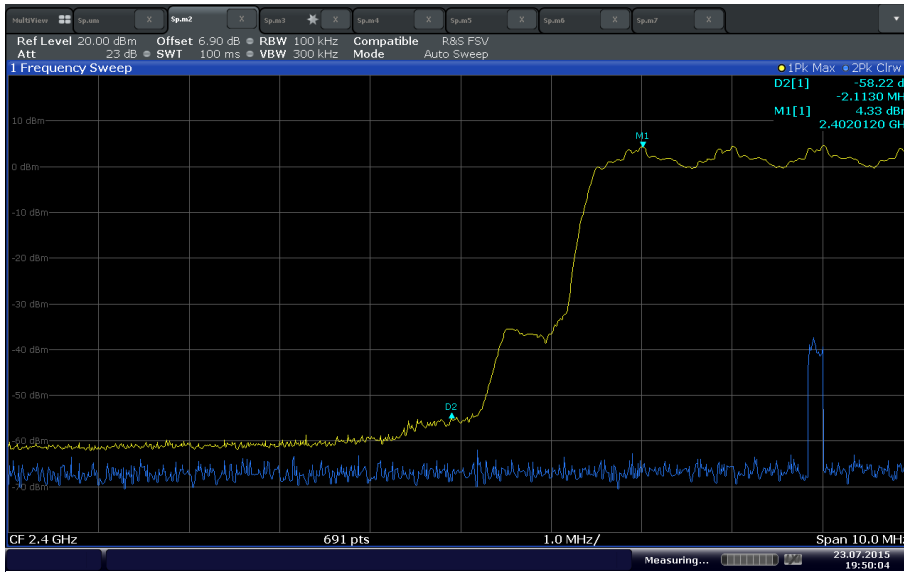

Date: 23\_JUL\_2015 19:50:04

Hopping lower bandedge ( $\pi/4$ -DQPSK)

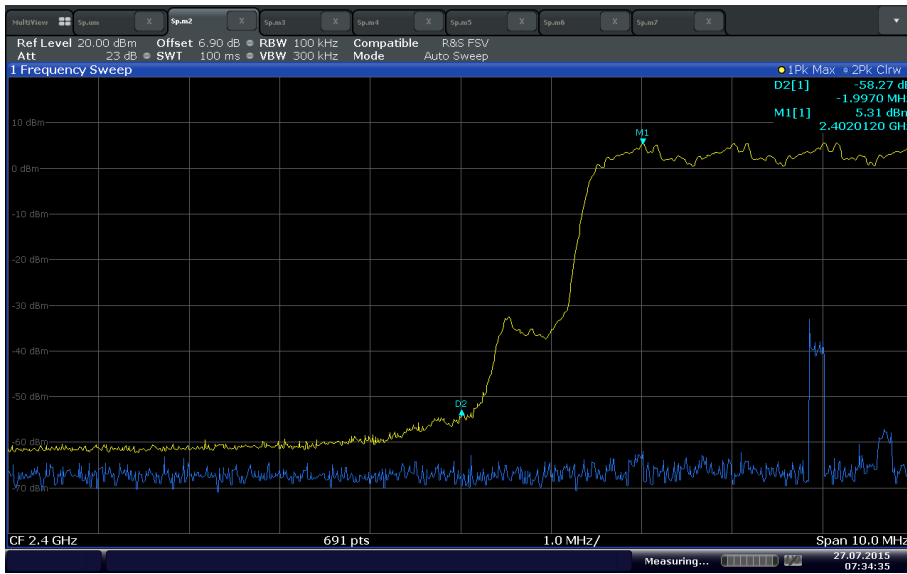

Date: 27 JUL 2015 07:34:35

### Hopping lower bandedge (8DPSK)

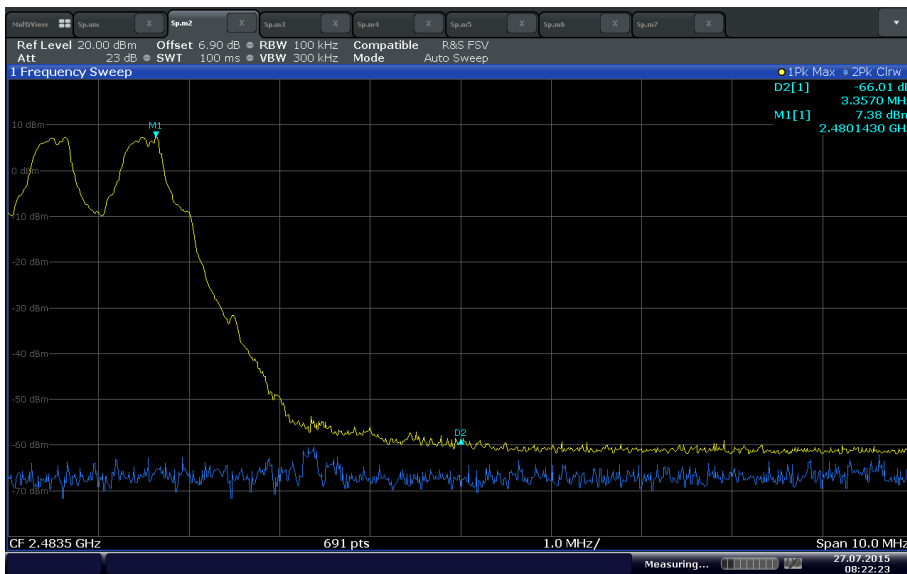

Date: 27 JUL 2015 08:22:23

### Hopping upper bandedge (GFSK)

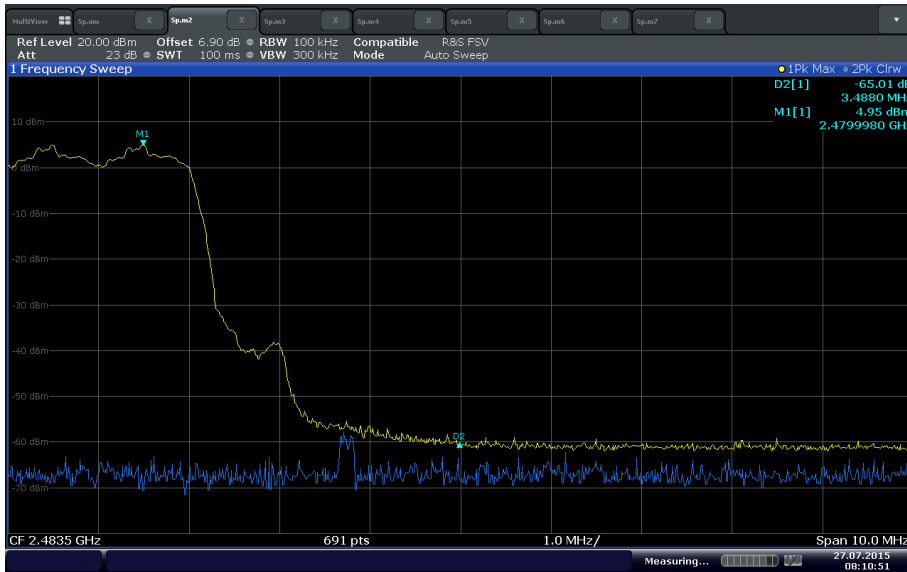

Date: 27 JUL 2015 08:10:51

### Hopping upper bandedge ( $\pi/4$ -DQPSK)

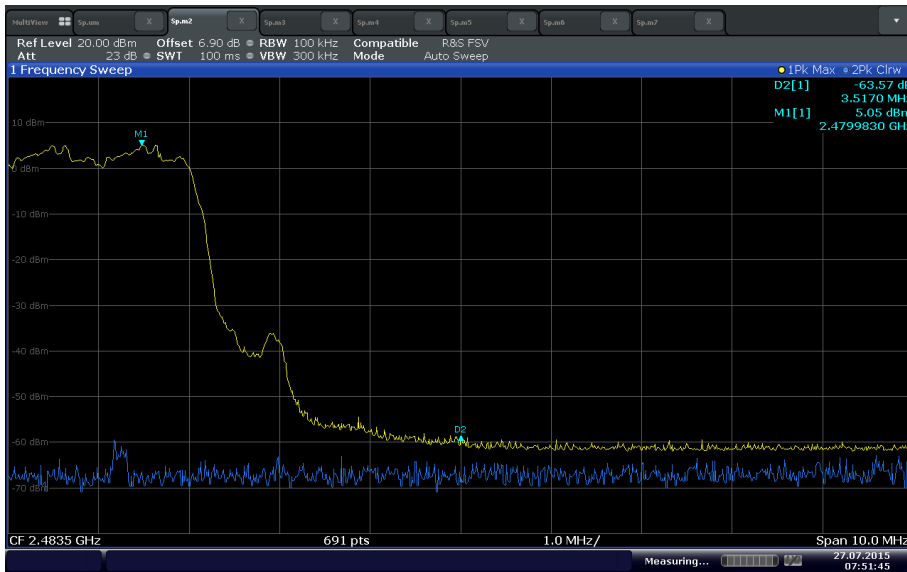

Date: 27 JUL 2015 07:51:46

### Hopping upper bandedge (8DPSK)

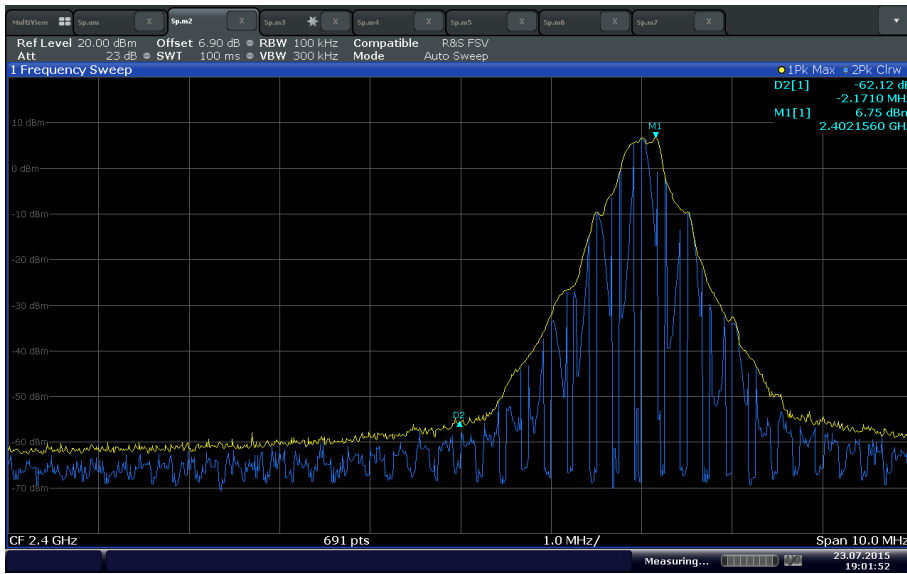

Date: 23 JUL 2015 19:01:51

### Non-hopping lower bandedge (GFSK)

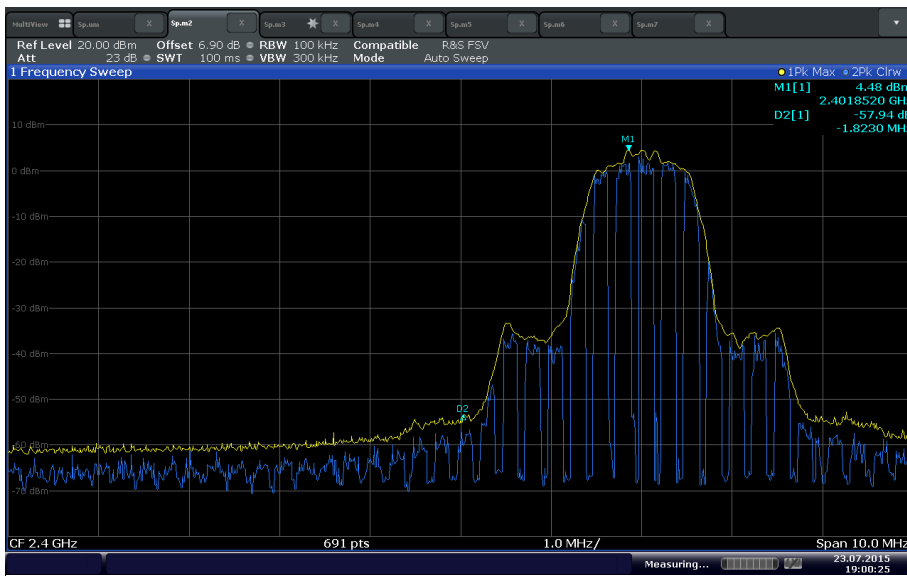

Date: 23 JUL 2015 19:00:25

### Non-hopping lower bandedge ( $\pi/4$ -DQPSK)

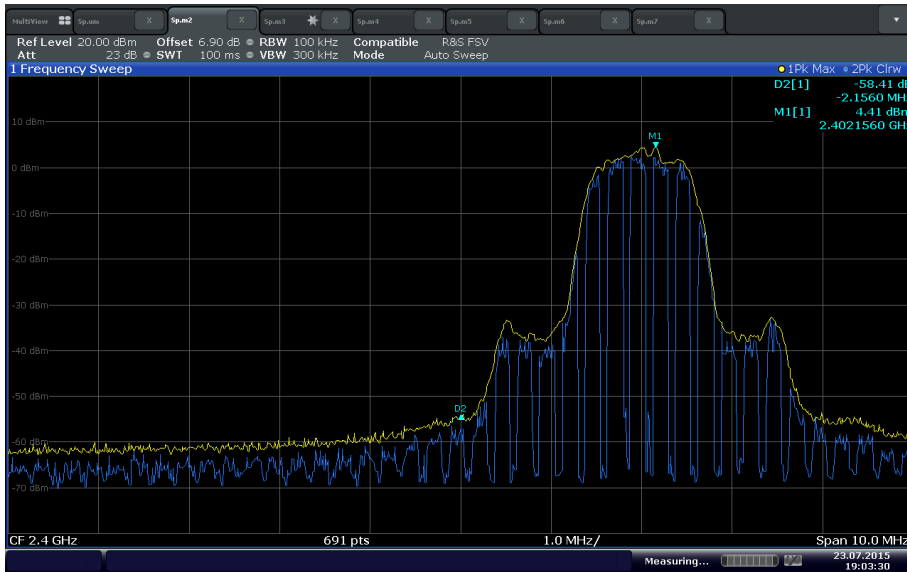

Date: 23 JUL 2015 19:03:30

**Non-hopping lower bandedge (8DPSK)**

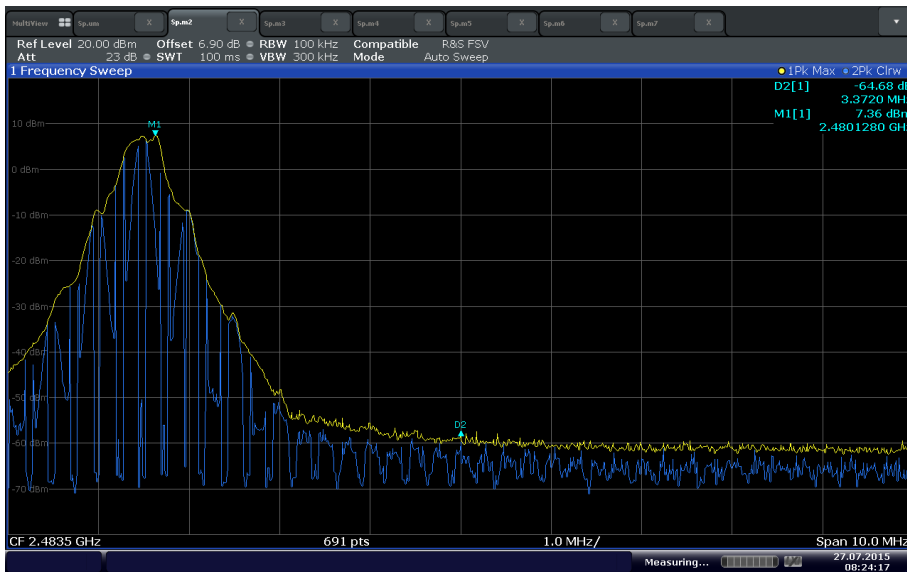

Date: 27 JUL 2015 08:24:18

**Non-hopping upper bandedge (GFSK)**

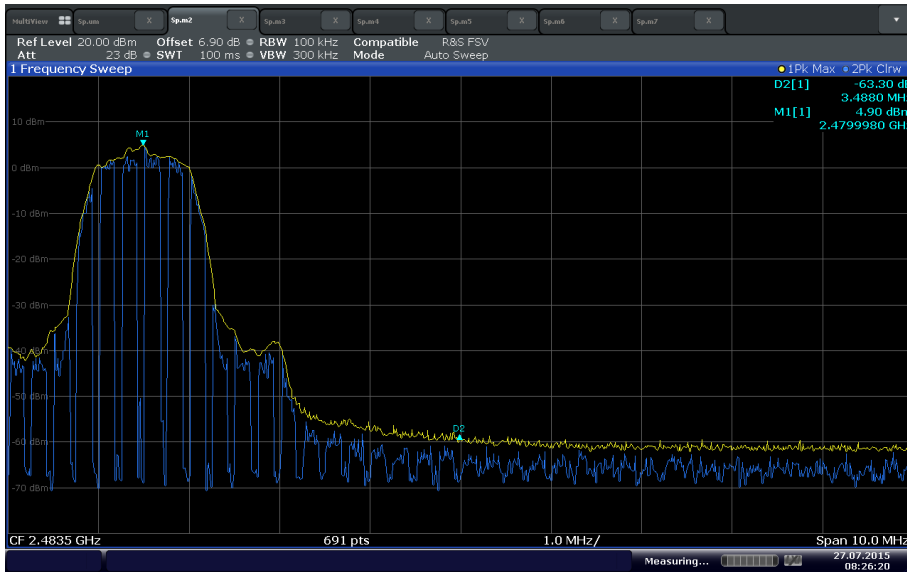

Date: 27 JUL 2015 08:26:20

Non-hopping upper bandedge ( $\pi/4$ -DQPSK)

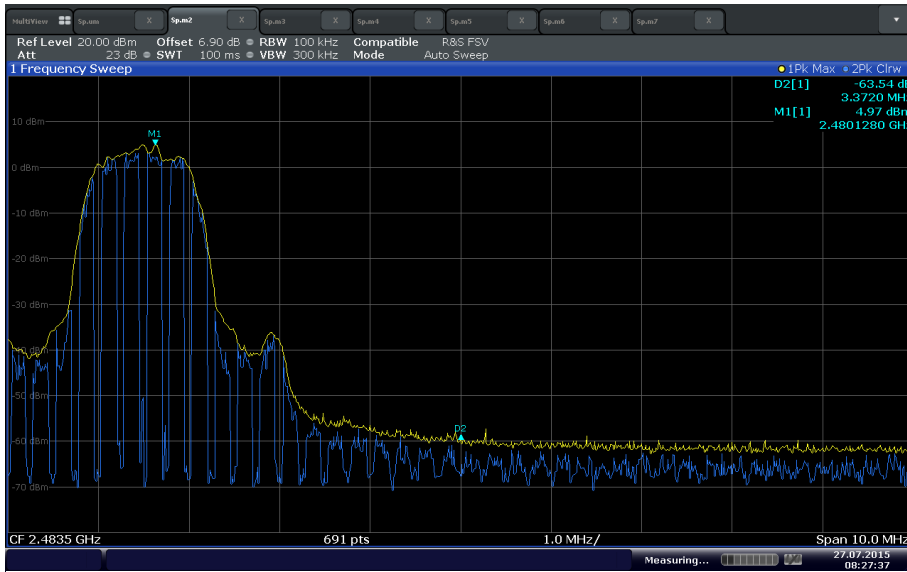

Date: 27 JUL 2015 08:27:37

Non-hopping upper bandedge (8DPSK)



## 2.8 SPURIOUS RF CONDUCTED EMISSIONS

### 2.8.1 Specification Reference

Part 15 Subpart C §15.247(d)

### 2.8.2 Standard Applicable

(d) In any 100 kHz bandwidth outside the frequency band in which the spread spectrum or digitally modulated intentional radiator is operating, the radio frequency power that is produced by the intentional radiator shall be at least 20 dB below that in the 100 kHz bandwidth within the band that contains the highest level of the desired power, based on either an RF conducted or a radiated measurement, provided the transmitter demonstrates compliance with the peak conducted power limits. If the transmitter complies with the conducted power limits based on the use of RMS averaging over a time interval, as permitted under paragraph (b)(3) of this section, the attenuation required under this paragraph shall be 30 dB instead of 20 dB. Attenuation below the general limits specified in §15.209(a) is not required. In addition, radiated emissions which fall in the restricted bands, as defined in §15.205(a), must also comply with the radiated emission limits specified in §15.209(a) (see §15.205(c)).

### 2.8.3 Equipment Under Test and Modification State

Serial No: C10015220002 /Test Configuration B

### 2.8.4 Date of Test/Initial of test personnel who performed the test

August 4, 2015/NS

### 2.8.5 Test Equipment Used

The major items of test equipment used for the above tests are identified in Section 3.1.

### 2.8.6 Environmental Conditions

Test performed at TÜV SÜD America Inc. Rancho Bernardo facility.

Ambient Temperature	24.8 °C
Relative Humidity	57.1 %
ATM Pressure	99.1 kPa

### 2.8.7 Additional Observations

- This is a conducted test.
- A TDF factor was used to compensate the power splitter and coaxial cable attenuation.
- Span is from 9 kHz up to 26.5GHz (to cover 1<sup>0th</sup> harmonic of the High Channel).
- Sweep point setting of the spectrum analyzer is set to maximum (32001).
- RBW is 100 kHz, VBW is  $\geq$  RBW.
- Sweep is auto, detector is peak.
- Trace is max hold.
- Trace allowed to stabilize. Maximum spurious emission compared to limit.
- Limit is 20dBc.

### 2.8.8 Test Results Plots

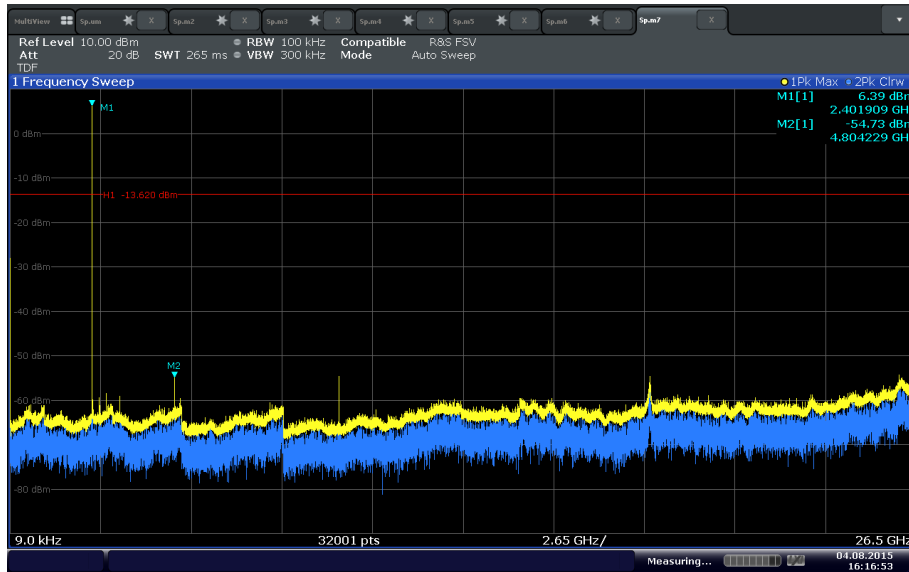

Date: 4 AUG 2015 16:16:54

Low Channel (GFSK)

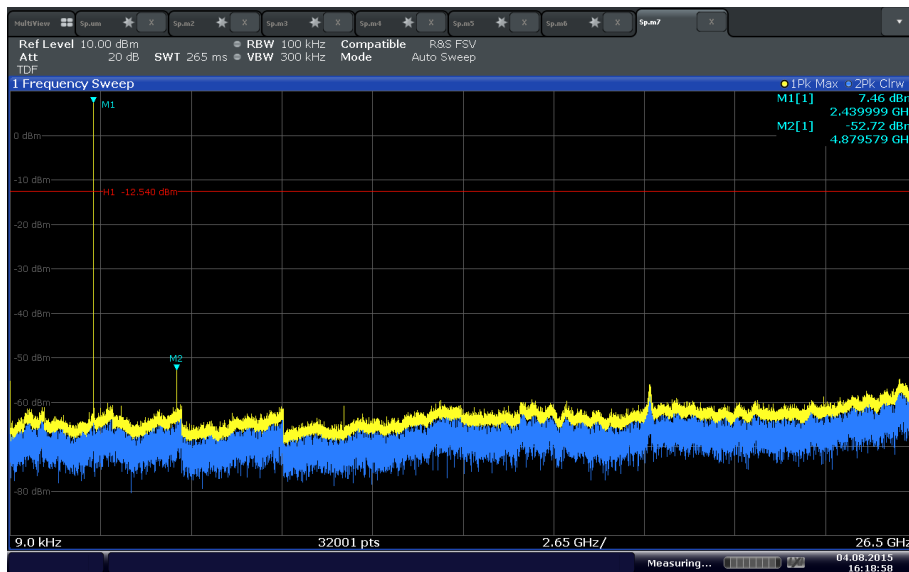

Date: 4 AUG 2015 16:18:58

Mid Channel (GFSK)

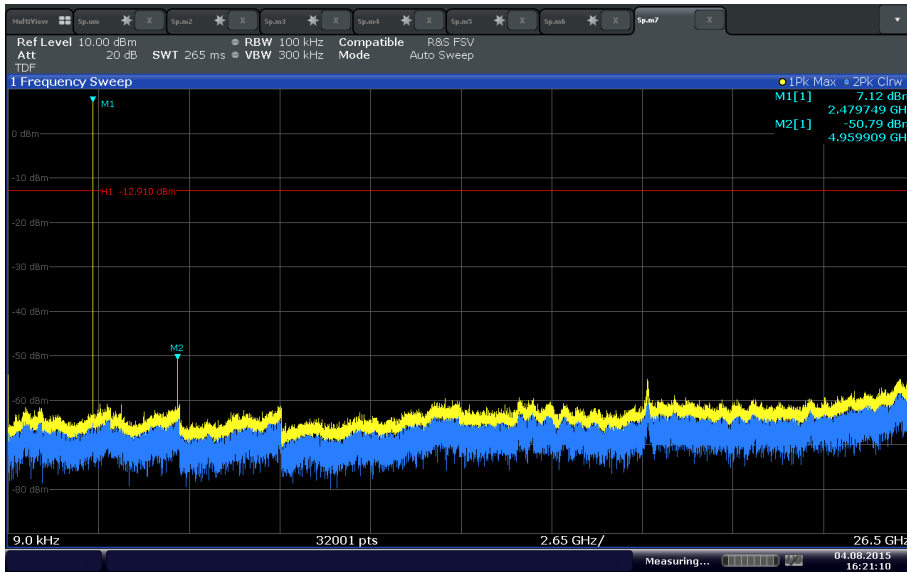

Date: 4.AUG.2015 16:21:10

### High Channel (GFSK)

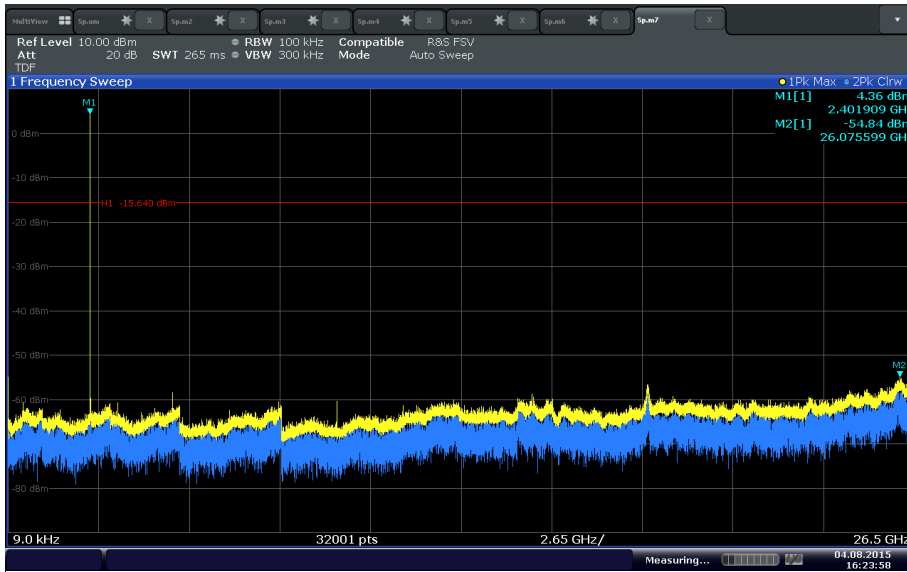

Date: 4.AUG.2015 16:23:58

### Low Channel ( $\pi/4$ -DQPSK)

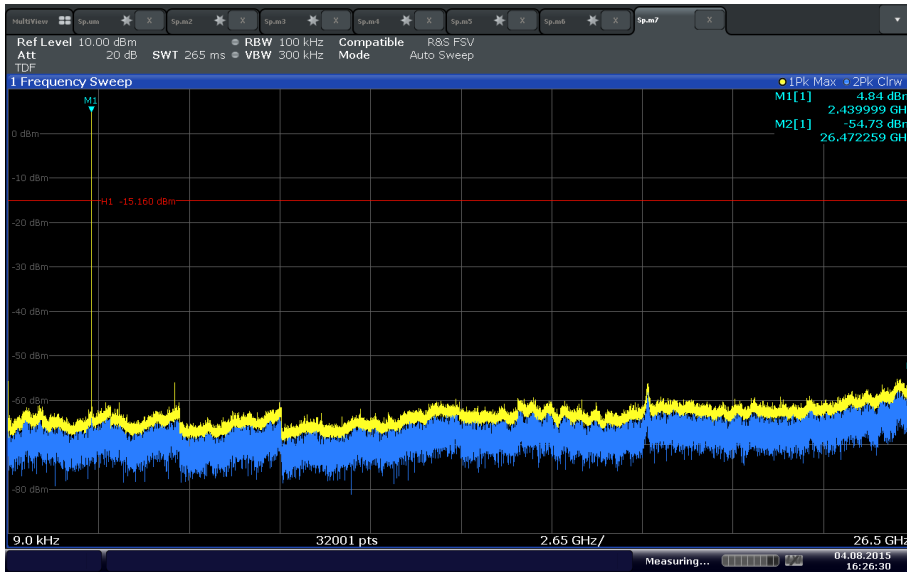

Date: 4.AUG.2015 16:26:30

### Mid Channel ( $\pi/4$ -DQPSK)

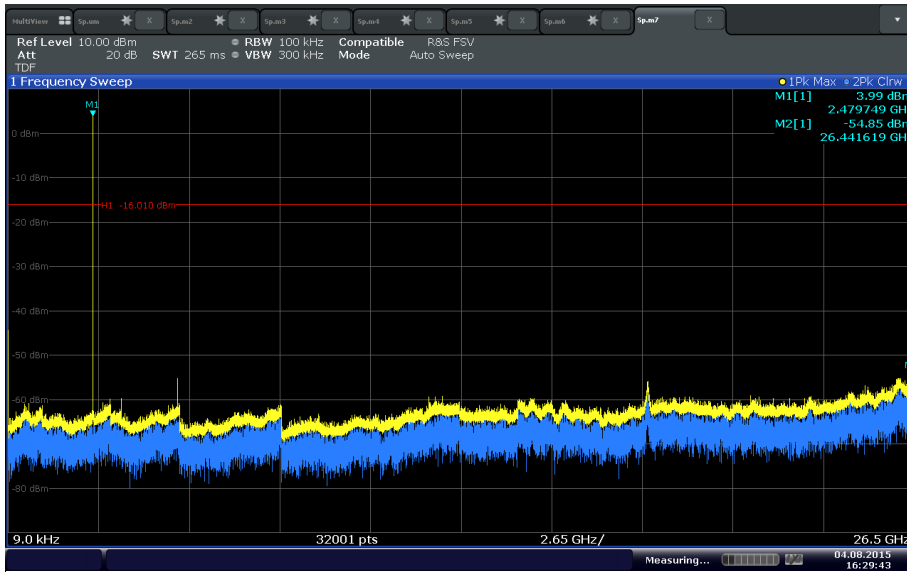

Date: 4.AUG.2015 16:29:44

### High Channel ( $\pi/4$ -DQPSK)

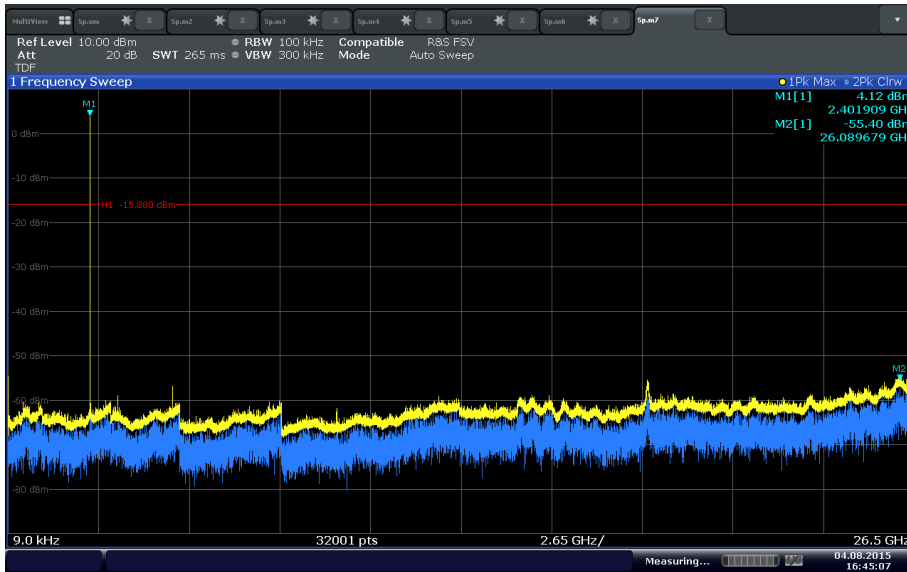

Date: 4.AUG.2015 16:45:07

Low Channel (8DPSK)

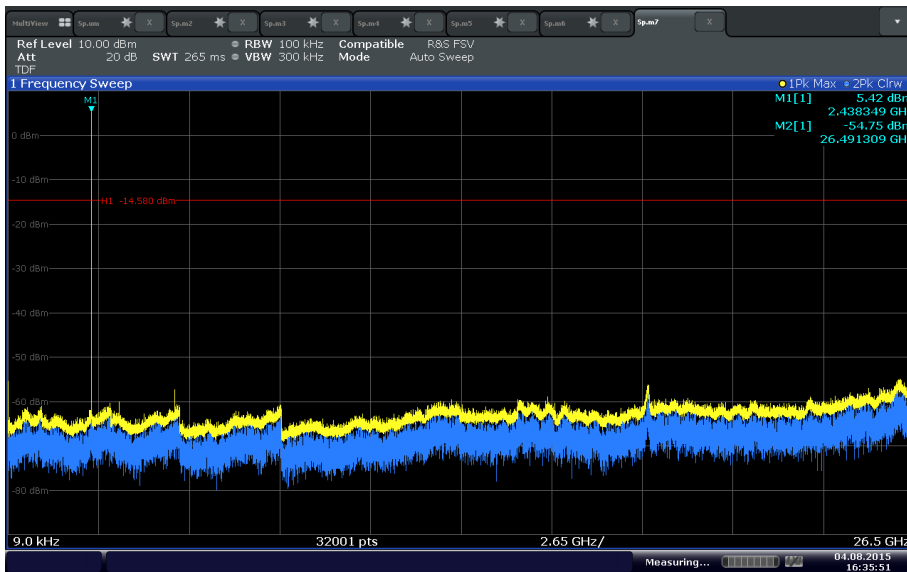

Date: 4.AUG.2015 16:35:51

Mid Channel (8DPSK)

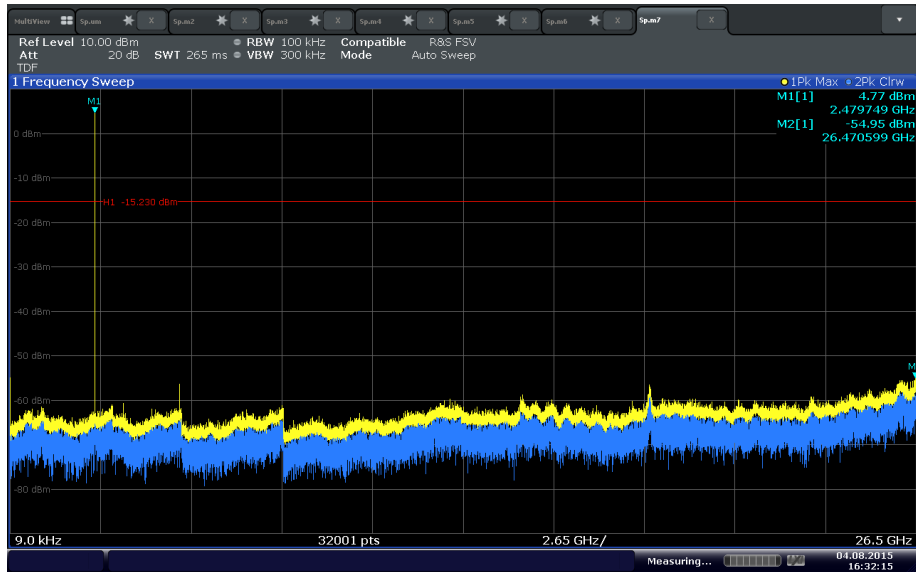

Date: 4 AUG 2015 16:32:16

### High Channel (8DPSK)



## **2.9 SPURIOUS RADIATED EMISSIONS**

### **2.9.1 Specification Reference**

Part 15 Subpart C §15.247(d)

### **2.9.2 Standard Applicable**

(d) In any 100 kHz bandwidth outside the frequency band in which the spread spectrum or digitally modulated intentional radiator is operating, the radio frequency power that is produced by the intentional radiator shall be at least 20 dB below that in the 100 kHz bandwidth within the band that contains the highest level of the desired power, based on either an RF conducted or a radiated measurement, provided the transmitter demonstrates compliance with the peak conducted power limits. If the transmitter complies with the conducted power limits based on the use of RMS averaging over a time interval, as permitted under paragraph (b)(3) of this section, the attenuation required under this paragraph shall be 30 dB instead of 20 dB. Attenuation below the general limits specified in §15.209(a) is not required. In addition, radiated emissions which fall in the restricted bands, as defined in §15.205(a), must also comply with the radiated emission limits specified in §15.209(a) (see §15.205(c)).

### **2.9.3 Equipment Under Test and Modification State**

Serial No: C10015220002 / Test Configuration B

### **2.9.4 Date of Test/Initial of test personnel who performed the test**

July 17, 2015/NS

### **2.9.5 Test Equipment Used**

The major items of test equipment used for the above tests are identified in Section 3.1.

### **2.9.6 Environmental Conditions**

Test performed at TÜV SÜD America Inc. Rancho Bernardo facility

Ambient Temperature	24.6°C
Relative Humidity	64.5%
ATM Pressure	99.1 kPa

### **2.9.7 Additional Observations**

- This is a radiated test. The spectrum was searched from 30MHz to the 10<sup>th</sup> harmonic.
- There are no emissions found that do not comply to the restricted bands defined in FCC Part 15 Subpart C, 15.205 or Part 15.247(d).
- Only the considered worst case configuration (mid channel GFSK) presented for radiated emissions when not hopping. There are no significant differences in radiated emissions between the three modulation types.



- Only noise floor measurements observed above 18GHz.
- Measurement was done using EMC32 automated software. Reported level is the actual level with all the correction factors factored in. Correction Factor column is for informational purposes only. See Section 2.9.8 for sample computation.

**2.9.8 Sample Computation (Radiated Emission)**

Measuring equipment raw measurement (dB $\mu$ V) @ 30 MHz		24.4
Correction Factor (dB)	Asset# 1066 (cable)	0.3
	Asset# 1172 (cable)	0.3
	Asset# 1016 (preamplifier)	-30.7
	Asset# 1175(cable)	0.3
	Asset# 1002 (antenna)	17.2
<b>Reported Quasi Peak Final Measurement (dB<math>\mu</math>V/m) @ 30MHz</b>		<b>11.8</b>

**2.9.9 Test Results**

See attached plots.



**2.9.10 Test Results Below 1GHz (Receive Mode)**

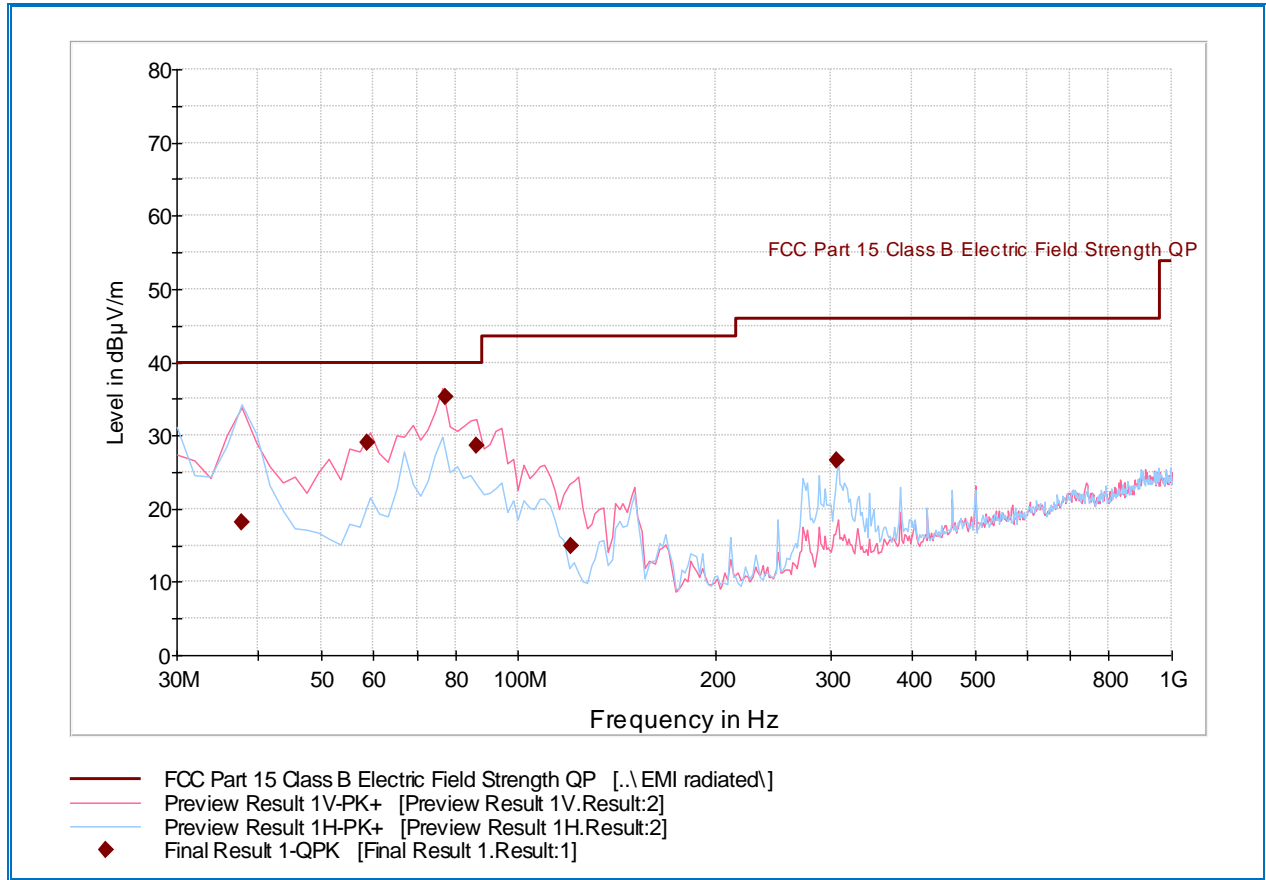

**Quasi Peak Data**

Frequency (MHz)	QuasiPeak (dBµV/m)	Meas. Time (ms)	Bandwidth (kHz)	Height (cm)	Polarization	Azimuth (deg)	Corr. (dB)	Margin (dB)	Limit (dBµV/m)
37.655551	18.2	1000.0	120.000	350.0	H	0.0	-15.5	21.8	40.0
58.718317	29.1	1000.0	120.000	106.0	V	233.0	-21.7	10.9	40.0
77.213307	35.4	1000.0	120.000	100.0	V	227.0	-22.2	4.6	40.0
86.092745	28.6	1000.0	120.000	100.0	V	235.0	-21.5	11.4	40.0
120.266613	14.9	1000.0	120.000	121.0	V	17.0	-20.4	28.6	43.5
307.215952	26.6	1000.0	120.000	106.0	H	89.0	-12.1	19.4	46.0



**2.9.11 Test Results Above 1GHz (Receive Mode)**

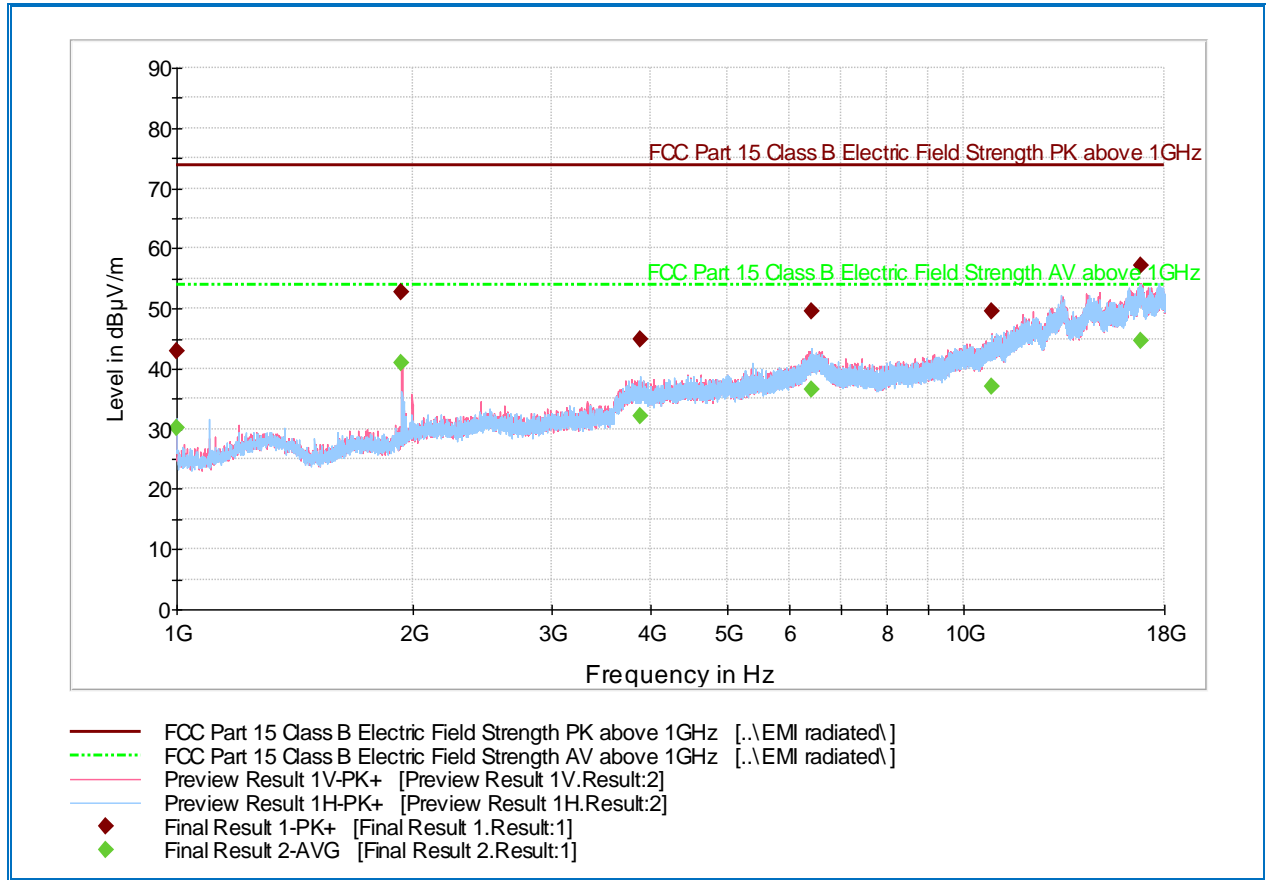

**Peak Data**

Frequency (MHz)	MaxPeak (dBµV/m)	Meas. Time (ms)	Bandwidth (kHz)	Height (cm)	Polarization	Azimuth (deg)	Corr. (dB)	Margin (dB)	Limit (dBµV/m)
1000.000000	43.0	1000.0	1000.000	264.3	H	-16.0	-7.2	30.9	73.9
1932.566667	52.7	1000.0	1000.000	309.2	V	261.0	-2.3	21.2	73.9
3884.900000	44.9	1000.0	1000.000	202.3	H	123.0	5.0	29.0	73.9
6400.133333	49.6	1000.0	1000.000	202.5	H	163.0	11.2	24.3	73.9
10874.13333	49.6	1000.0	1000.000	302.2	V	16.0	14.5	24.3	73.9
16803.96666	57.1	1000.0	1000.000	266.3	V	236.0	23.8	16.8	73.9

**Average Data**

Frequency (MHz)	Average (dBµV/m)	Meas. Time (ms)	Bandwidth (kHz)	Height (cm)	Polarization	Azimuth (deg)	Corr. (dB)	Margin (dB)	Limit (dBµV/m)
1000.000000	30.2	1000.0	1000.000	264.3	H	-16.0	-7.2	23.7	53.9
1932.566667	41.1	1000.0	1000.000	309.2	V	261.0	-2.3	12.8	53.9
3884.900000	32.2	1000.0	1000.000	202.3	H	123.0	5.0	21.7	53.9
6400.133333	36.6	1000.0	1000.000	202.5	H	163.0	11.2	17.3	53.9
10874.13333	36.9	1000.0	1000.000	302.2	V	16.0	14.5	17.0	53.9
16803.96666	44.5	1000.0	1000.000	266.3	V	236.0	23.8	9.4	53.9

**Test Notes:** No significant emissions observed above 3GHz.

**2.9.12 Test Results Below 1GHz (Bluetooth TX Worst Case – Non-hopping)**

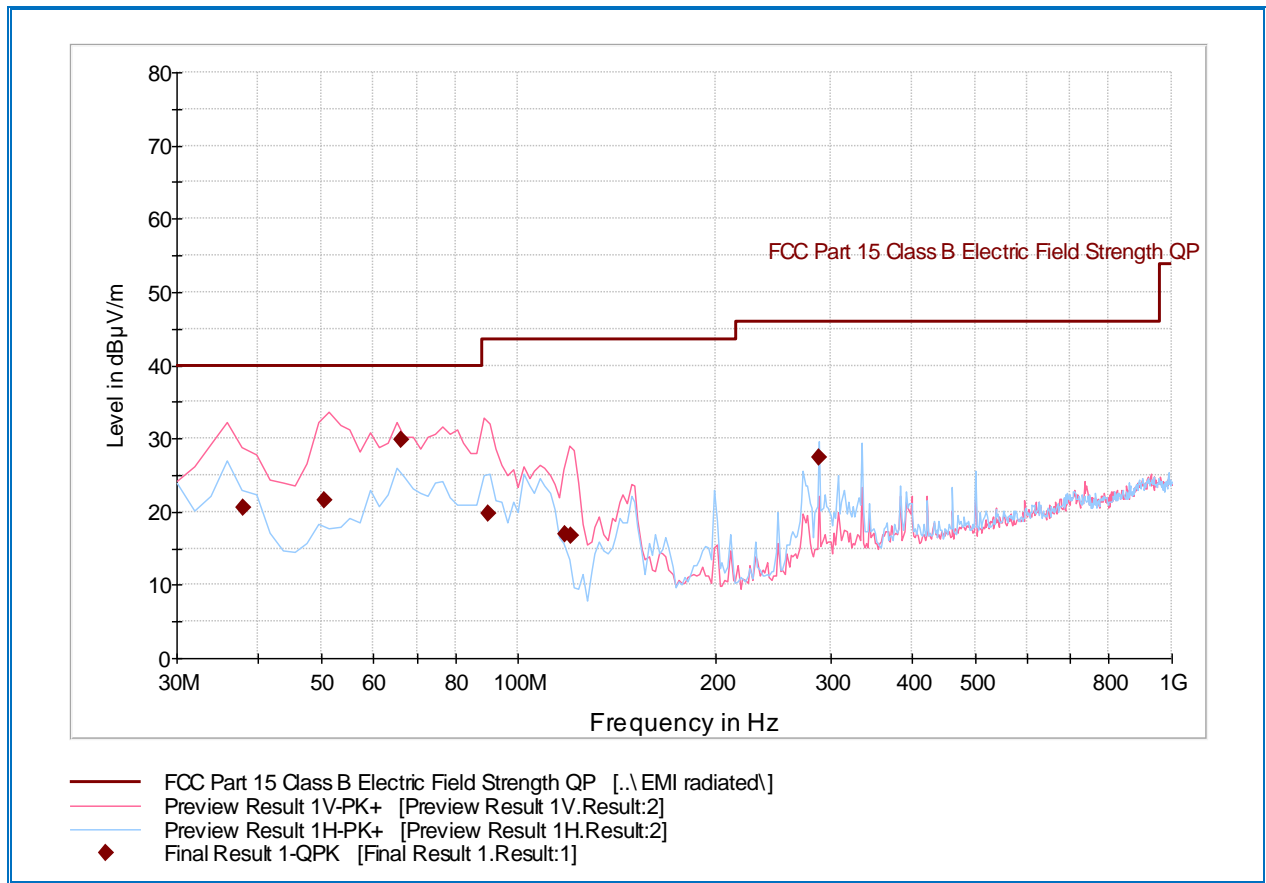

**Quasi Peak Data**

Frequency (MHz)	QuasiPeak (dBµV/m)	Meas. Time (ms)	Bandwidth (kHz)	Height (cm)	Polarization	Azimuth (deg)	Corr. (dB)	Margin (dB)	Limit (dBµV/m)
37.991663	20.6	1000.0	120.000	121.0	V	306.0	-15.7	19.4	40.0
50.422766	21.5	1000.0	120.000	100.0	V	1.0	-20.0	18.5	40.0
66.269980	29.9	1000.0	120.000	172.0	V	225.0	-22.3	10.1	40.0
89.956633	19.7	1000.0	120.000	100.0	V	-11.0	-20.8	23.8	43.5
117.658838	16.9	1000.0	120.000	100.0	V	18.0	-20.2	26.6	43.5
120.546613	16.7	1000.0	120.000	100.0	V	69.0	-20.4	26.8	43.5
288.017074	27.4	1000.0	120.000	100.0	H	316.0	-13.4	18.6	46.0

**Test Notes:** Only worst case channel presented for spurious emissions below 1GHz.



**2.9.13 Test Results Below 1GHz (Bluetooth TX Worst Case – Hopping)**

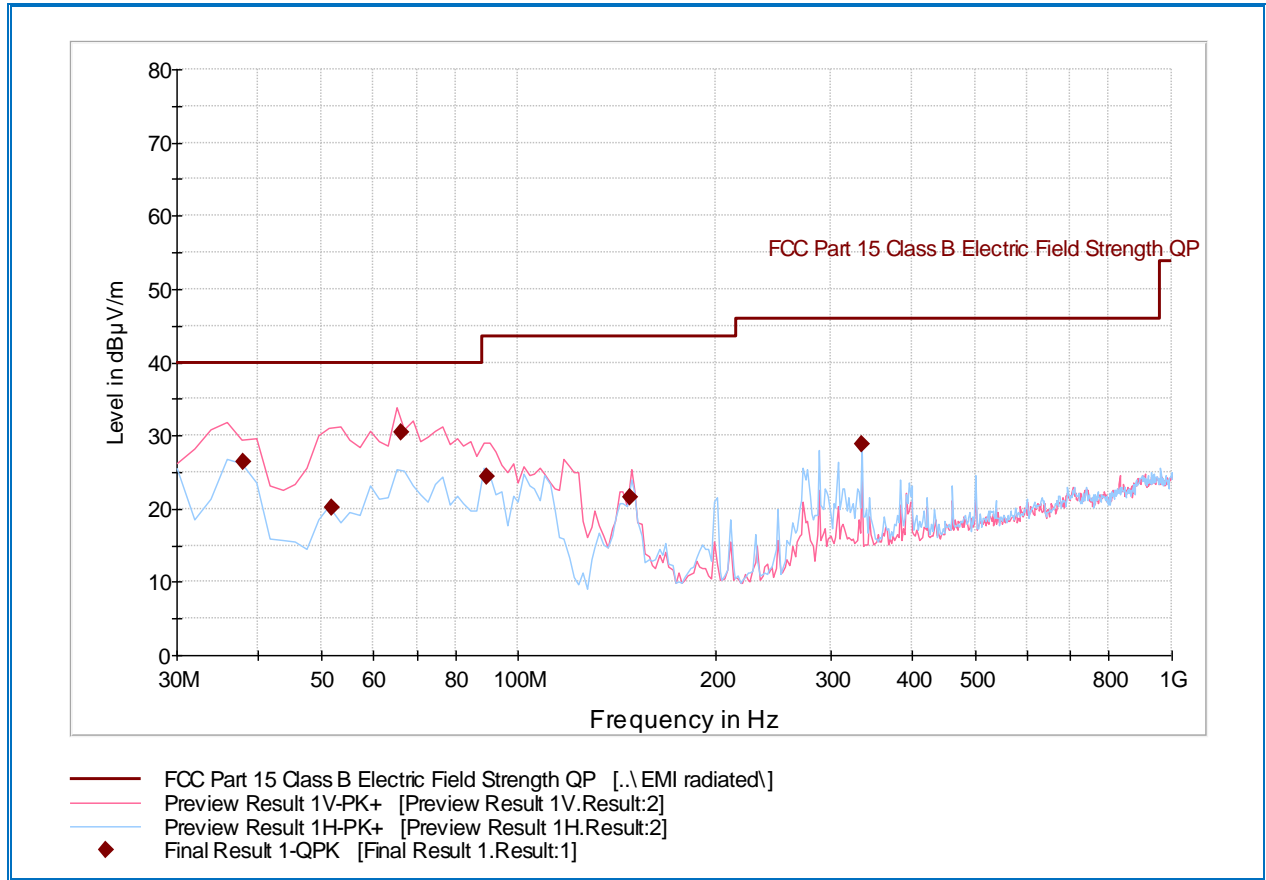

**Quasi Peak Data**

Frequency (MHz)	QuasiPeak (dBµV/m)	Meas. Time (ms)	Bandwidth (kHz)	Height (cm)	Polarization	Azimuth (deg)	Corr. (dB)	Margin (dB)	Limit (dBµV/m)
37.991663	26.4	1000.0	120.000	100.0	V	76.0	-15.7	13.6	40.0
51.806653	20.2	1000.0	120.000	106.0	V	95.0	-20.3	19.8	40.0
66.269980	30.4	1000.0	120.000	100.0	V	206.0	-22.3	9.6	40.0
89.652745	24.4	1000.0	120.000	100.0	V	216.0	-20.9	19.1	43.5
148.097154	21.5	1000.0	120.000	100.0	V	207.0	-19.1	22.0	43.5
335.990381	28.9	1000.0	120.000	100.0	H	288.0	-11.4	17.1	46.0



**2.9.14 Test Results Above 1GHz (Bluetooth TX Worst Case – Hopping)**

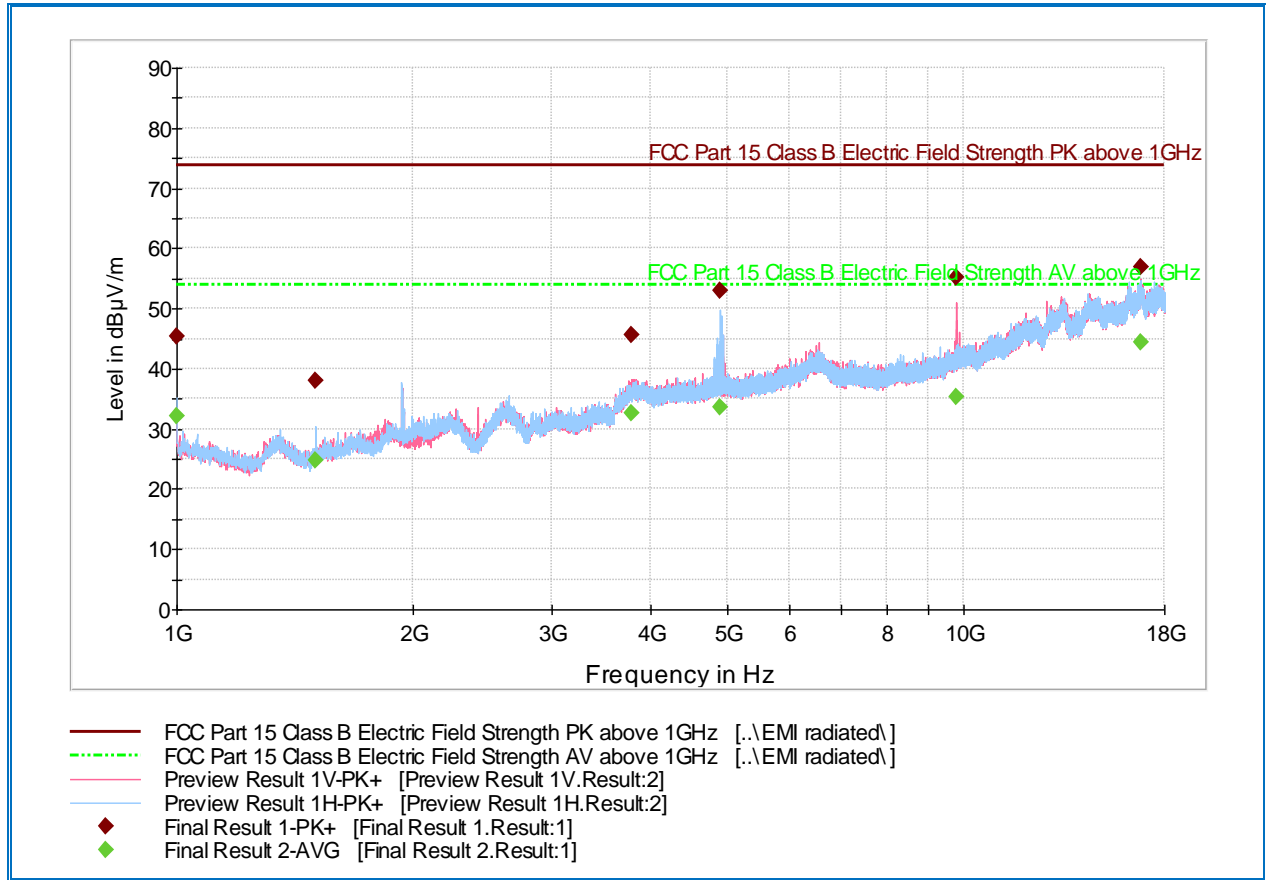

**Peak Data**

Frequency (MHz)	MaxPeak (dBµV/m)	Meas. Time (ms)	Bandwidth (kHz)	Height (cm)	Polarization	Azimuth (deg)	Corr. (dB)	Margin (dB)	Limit (dBµV/m)
1000.000000	45.3	1000.0	1000.000	302.2	H	4.0	-7.2	28.6	73.9
1500.800000	38.0	1000.0	1000.000	191.5	H	85.0	-6.0	35.9	73.9
3782.366667	45.5	1000.0	1000.000	148.7	V	-9.0	4.8	28.4	73.9
4901.866667	53.0	1000.0	1000.000	200.5	H	-3.0	6.2	20.9	73.9
9787.866667	55.2	1000.0	1000.000	216.4	V	322.0	12.0	18.7	73.9
16805.466667	56.9	1000.0	1000.000	154.6	V	338.0	23.8	17.0	73.9

**Average Data**

Frequency (MHz)	Average (dBµV/m)	Meas. Time (ms)	Bandwidth (kHz)	Height (cm)	Polarization	Azimuth (deg)	Corr. (dB)	Margin (dB)	Limit (dBµV/m)
1000.000000	32.2	1000.0	1000.000	302.2	H	4.0	-7.2	21.7	53.9
1500.800000	24.8	1000.0	1000.000	191.5	H	85.0	-6.0	29.1	53.9
3782.366667	32.7	1000.0	1000.000	148.7	V	-9.0	4.8	21.2	53.9
4901.866667	33.7	1000.0	1000.000	200.5	H	-3.0	6.2	20.2	53.9
9787.866667	35.3	1000.0	1000.000	216.4	V	322.0	12.0	18.6	53.9
16805.466667	44.4	1000.0	1000.000	154.6	V	338.0	23.8	9.5	53.9

**Test Notes:** Measurement was performed with a 2.4GHz notch filter.



**2.9.15 Test Results Above 1GHz Low Channel (Bluetooth TX Worst Case)**

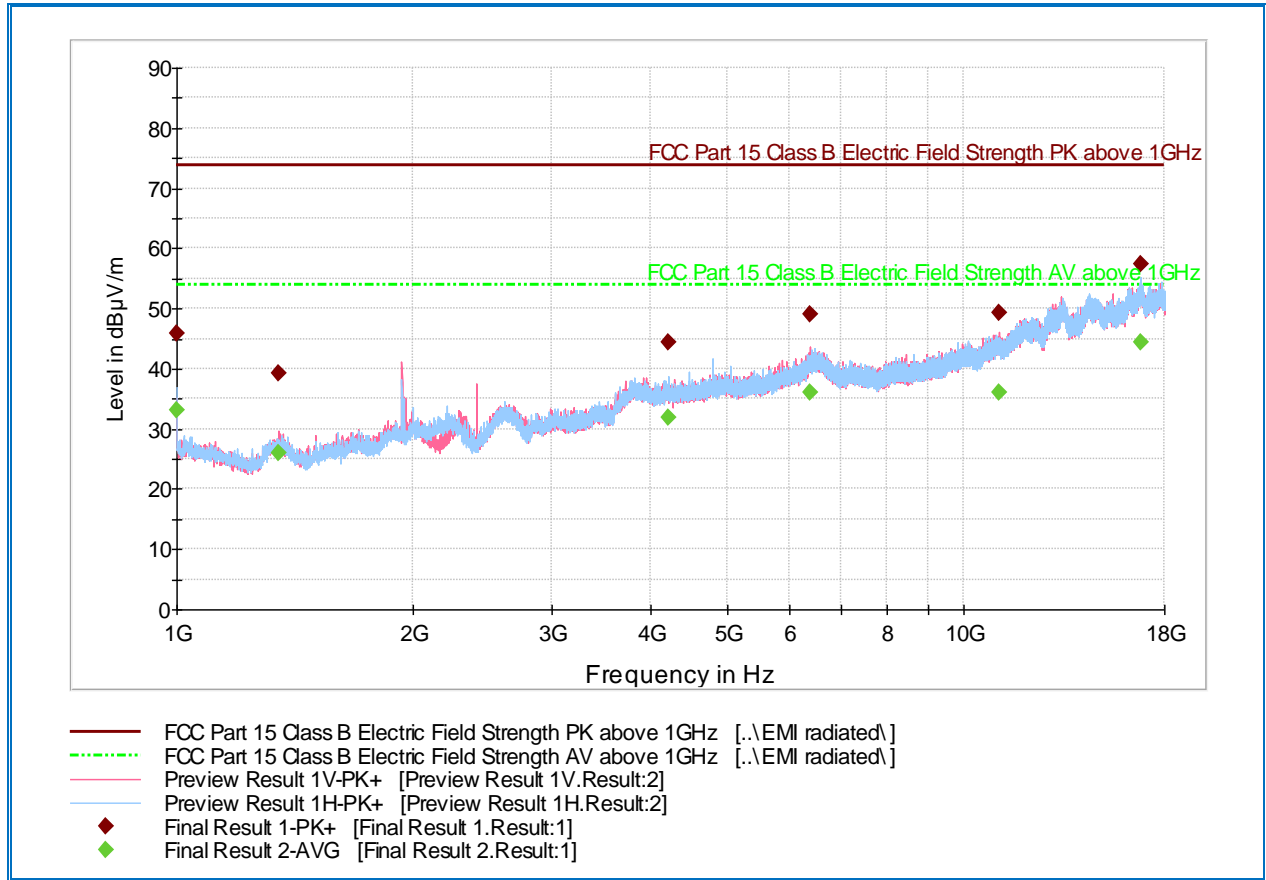

**Peak Data**

Frequency (MHz)	MaxPeak (dBµV/m)	Meas. Time (ms)	Bandwidth (kHz)	Height (cm)	Polarization	Azimuth (deg)	Corr. (dB)	Margin (dB)	Limit (dBµV/m)
1000.000000	45.8	1000.0	1000.000	289.3	H	91.0	-7.2	28.1	73.9
1346.366667	39.2	1000.0	1000.000	202.5	V	143.0	-5.4	34.7	73.9
4220.200000	44.4	1000.0	1000.000	332.2	H	249.0	5.1	29.5	73.9
6392.433333	49.0	1000.0	1000.000	164.6	V	257.0	11.2	24.9	73.9
11114.833333	49.3	1000.0	1000.000	311.2	V	150.0	14.4	24.6	73.9
16770.333333	57.3	1000.0	1000.000	402.1	H	103.0	23.6	16.6	73.9

**Average Data**

Frequency (MHz)	Average (dBµV/m)	Meas. Time (ms)	Bandwidth (kHz)	Height (cm)	Polarization	Azimuth (deg)	Corr. (dB)	Margin (dB)	Limit (dBµV/m)
1000.000000	33.1	1000.0	1000.000	289.3	H	91.0	-7.2	20.8	53.9
1346.366667	26.0	1000.0	1000.000	202.5	V	143.0	-5.4	27.9	53.9
4220.200000	31.8	1000.0	1000.000	332.2	H	249.0	5.1	22.1	53.9
6392.433333	36.0	1000.0	1000.000	164.6	V	257.0	11.2	17.9	53.9
11114.833333	36.1	1000.0	1000.000	311.2	V	150.0	14.4	17.8	53.9
16770.333333	44.3	1000.0	1000.000	402.1	H	103.0	23.6	9.6	53.9

**Test Notes:** Measurement was performed with a 2.4GHz notch filter.



**2.9.16 Test Results Above 1GHz Mid Channel (Bluetooth TX Worst Case)**

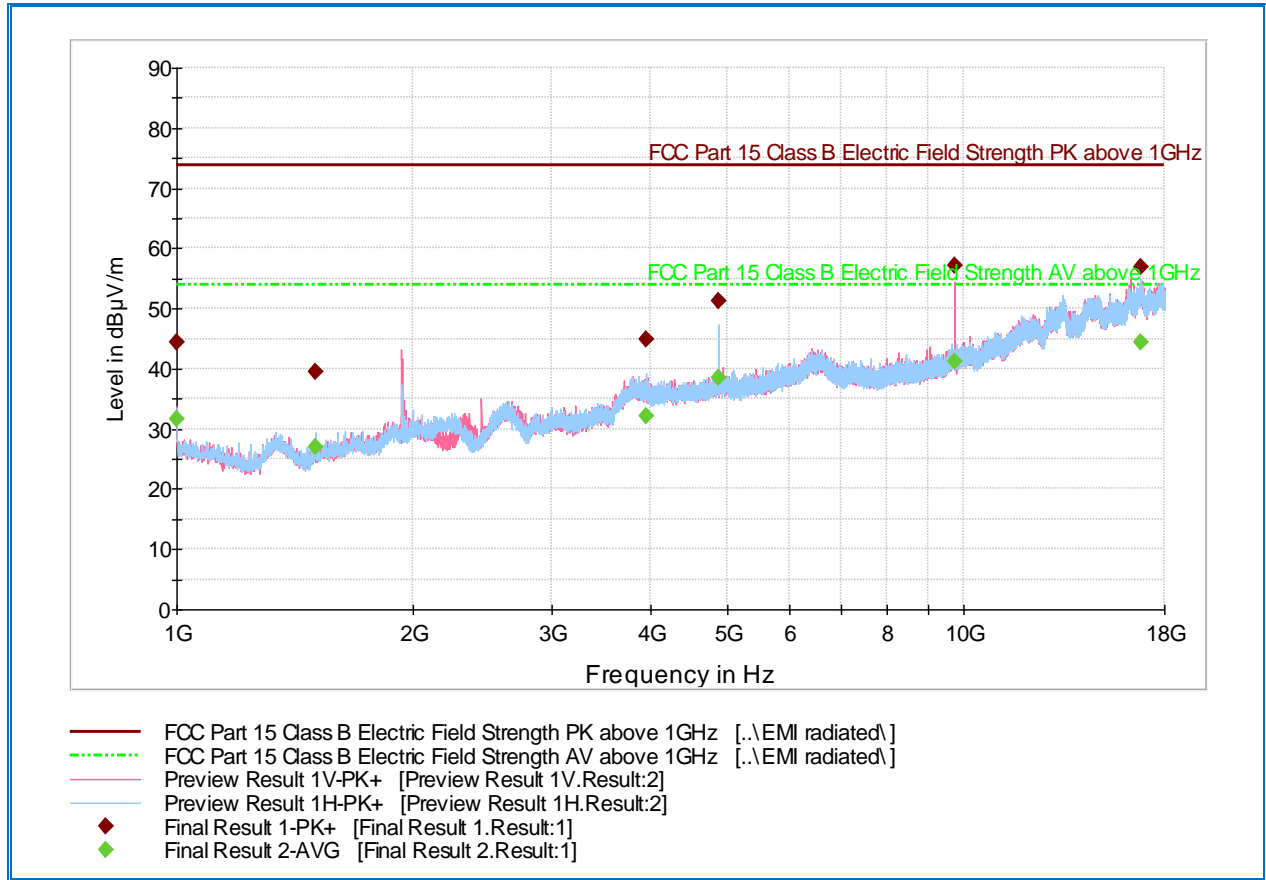

**Peak Data**

Frequency (MHz)	MaxPeak (dBµV/m)	Meas. Time (ms)	Bandwidth (kHz)	Height (cm)	Polarization	Azimuth (deg)	Corr. (dB)	Margin (dB)	Limit (dBµV/m)
1000.000000	44.4	1000.0	1000.000	276.3	V	20.0	-7.2	29.5	73.9
1500.200000	39.5	1000.0	1000.000	189.5	H	327.0	-6.0	34.4	73.9
3957.433333	44.8	1000.0	1000.000	116.7	H	2.0	5.0	29.1	73.9
4879.766667	51.2	1000.0	1000.000	234.4	H	-3.0	6.1	22.7	73.9
9759.333333	57.1	1000.0	1000.000	172.6	V	322.0	12.0	16.8	73.9
16805.500000	57.0	1000.0	1000.000	246.4	H	270.0	23.8	16.9	73.9

**Average Data**

Frequency (MHz)	Average (dBµV/m)	Meas. Time (ms)	Bandwidth (kHz)	Height (cm)	Polarization	Azimuth (deg)	Corr. (dB)	Margin (dB)	Limit (dBµV/m)
1000.000000	31.7	1000.0	1000.000	276.3	V	20.0	-7.2	22.2	53.9
1500.200000	27.0	1000.0	1000.000	189.5	H	327.0	-6.0	26.9	53.9
3957.433333	32.1	1000.0	1000.000	116.7	H	2.0	5.0	21.8	53.9
4879.766667	38.4	1000.0	1000.000	234.4	H	-3.0	6.1	15.5	53.9
9759.333333	41.1	1000.0	1000.000	172.6	V	322.0	12.0	12.8	53.9
16805.500000	44.4	1000.0	1000.000	246.4	H	270.0	23.8	9.5	53.9

**Test Notes:** Measurement was performed with a 2.4GHz notch filter.

**2.9.17 Test Results Above 1GHz High Channel (Bluetooth TX Worst Case)**

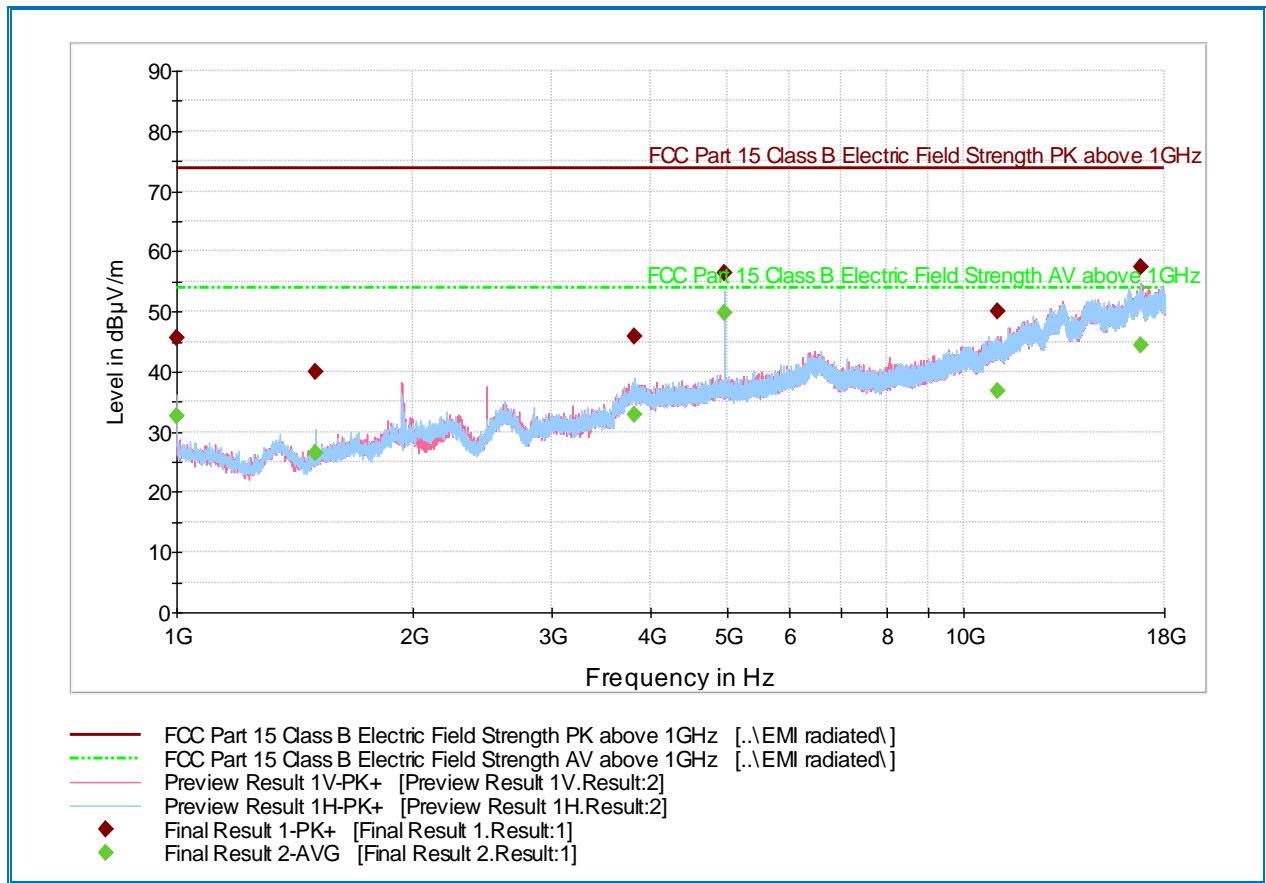

**Peak Data**

Frequency (MHz)	MaxPeak (dBµV/m)	Meas. Time (ms)	Bandwidth (kHz)	Height (cm)	Polarization	Azimuth (deg)	Corr. (dB)	Margin (dB)	Limit (dBµV/m)
1000.000000	45.6	1000.0	1000.000	298.2	H	78.0	-7.2	28.3	73.9
1500.400000	39.9	1000.0	1000.000	132.7	H	249.0	-6.0	34.0	73.9
3815.066667	45.8	1000.0	1000.000	255.4	H	-16.0	4.9	28.1	73.9
4960.066667	56.4	1000.0	1000.000	198.5	H	-9.0	6.4	17.5	73.9
11052.333333	50.0	1000.0	1000.000	164.6	V	254.0	14.7	23.9	73.9
16809.833333	57.3	1000.0	1000.000	379.1	V	20.0	23.7	16.6	73.9

**Average Data**

Frequency (MHz)	Average (dBµV/m)	Meas. Time (ms)	Bandwidth (kHz)	Height (cm)	Polarization	Azimuth (deg)	Corr. (dB)	Margin (dB)	Limit (dBµV/m)
1000.000000	32.7	1000.0	1000.000	298.2	H	78.0	-7.2	21.2	53.9
1500.400000	26.6	1000.0	1000.000	132.7	H	249.0	-6.0	27.3	53.9
3815.066667	33.0	1000.0	1000.000	255.4	H	-16.0	4.9	20.9	53.9
4960.066667	49.9	1000.0	1000.000	198.5	H	-9.0	6.4	4.0	53.9
11052.333333	36.9	1000.0	1000.000	164.6	V	254.0	14.7	17.0	53.9
16809.833333	44.4	1000.0	1000.000	379.1	V	20.0	23.7	9.5	53.9

**Test Notes:** Measurement was performed with a 2.4GHz notch filter.





**2.10 RADIATED IMMEDIATE RESTRICTED BANDS**

**2.10.1 Specification Reference**

Part 15 Subpart C §15.247(d)

**2.10.2 Standard Applicable**

(d) In any 100 kHz bandwidth outside the frequency band in which the spread spectrum or digitally modulated intentional radiator is operating, the radio frequency power that is produced by the intentional radiator shall be at least 20 dB below that in the 100 kHz bandwidth within the band that contains the highest level of the desired power, based on either an RF conducted or a radiated measurement, provided the transmitter demonstrates compliance with the peak conducted power limits. If the transmitter complies with the conducted power limits based on the use of RMS averaging over a time interval, as permitted under paragraph (b)(3) of this section, the attenuation required under this paragraph shall be 30 dB instead of 20 dB. Attenuation below the general limits specified in §15.209(a) is not required. In addition, radiated emissions which fall in the restricted bands, as defined in §15.205(a), must also comply with the radiated emission limits specified in §15.209(a) (see §15.205(c)).

**2.10.3 Equipment Under Test and Modification State**

Serial No: C10015220002 / Test Configuration B

**2.10.4 Date of Test/Initial of test personnel who performed the test**

July 17, 2015/NS

**2.10.5 Test Equipment Used**

The major items of test equipment used for the above tests are identified in Section 3.1.

**2.10.6 Environmental Conditions**

Test performed at TÜV SÜD America Inc. Rancho Bernardo facility

Ambient Temperature	24.6°C
Relative Humidity	64.5%
ATM Pressure	99.1 kPa

**2.10.7 Additional Observations**

- This is a radiated test. The spectrum was searched from 2310MHz to 2390MHz for lower immediate restricted band and 2483.5MHz to 2500MHz for the upper immediate restricted band.
- There are no emissions found that do not comply with the restricted bands defined in FCC Part 15 Subpart C, 15.205.
- Both Non-hopping and Hopping modes were verified. Test data for Hopping mode is presented as the worst-case.



- Measurement was done using EMC32 automated software. Reported level is the actual level with all the correction factors factored in. Correction Factor column is for informational purposes only. See Section 2.10.8 for sample computation.

**2.10.8 Sample Computation (Radiated Emission)**

Measuring equipment raw measurement (dB $\mu$ V) @ 2400 MHz		53.9
Correction Factor (dB)	Asset# 1153 (cable)	3.4
	Asset# 8628(preamplifier)	-36.5
	Asset#7575 (antenna)	32.7
<b>Reported Max Peak Final Measurement (dB<math>\mu</math>V/m) @ 2400 MHz</b>		<b>53.5</b>

**2.10.9 Test Results**

See attached plots.



**2.10.10 Test Results Restricted Band 2310MHz to 2390MHz (Hopping)**

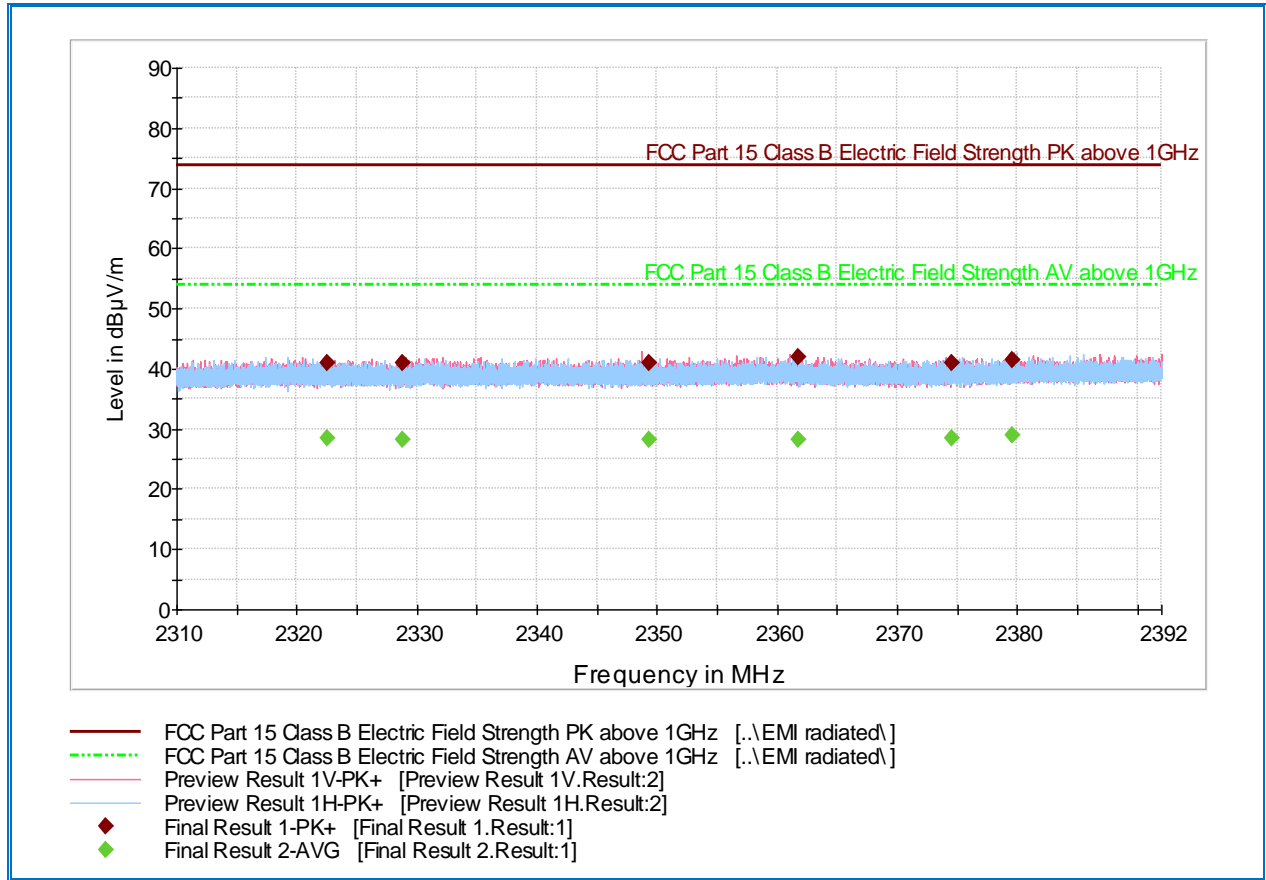

**Peak Data**

Frequency (MHz)	MaxPeak (dBµV/m)	Meas. Time (ms)	Bandwidth (kHz)	Height (cm)	Polarization	Azimuth (deg)	Corr. (dB)	Margin (dB)	Limit (dBµV/m)
2322.576533	41.0	1000.0	1000.000	225.4	V	161.0	-0.7	32.9	73.9
2328.867733	40.8	1000.0	1000.000	102.8	V	-20.0	-0.7	33.1	73.9
2349.366867	40.9	1000.0	1000.000	200.5	V	351.0	-0.8	33.0	73.9
2361.795800	41.8	1000.0	1000.000	127.1	V	338.0	-0.7	32.1	73.9
2374.601000	41.0	1000.0	1000.000	200.5	V	14.0	-0.7	32.9	73.9
2379.541000	41.4	1000.0	1000.000	176.6	V	110.0	-0.7	32.5	73.9

**Average Data**

Frequency (MHz)	Average (dBµV/m)	Meas. Time (ms)	Bandwidth (kHz)	Height (cm)	Polarization	Azimuth (deg)	Corr. (dB)	Margin (dB)	Limit (dBµV/m)
2322.576533	28.5	1000.0	1000.000	225.4	V	161.0	-0.7	25.4	53.9
2328.867733	28.1	1000.0	1000.000	102.8	V	-20.0	-0.7	25.8	53.9
2349.366867	28.2	1000.0	1000.000	200.5	V	351.0	-0.8	25.7	53.9
2361.795800	28.3	1000.0	1000.000	127.1	V	338.0	-0.7	25.6	53.9
2374.601000	28.5	1000.0	1000.000	200.5	V	14.0	-0.7	25.4	53.9
2379.541000	28.8	1000.0	1000.000	176.6	V	110.0	-0.7	25.1	53.9

**Test Notes:** 2.4GHz notch filter removed for this test.



**2.10.11 Test Results Restricted Band 2483.5MHz to 2500MHz (Hopping)**

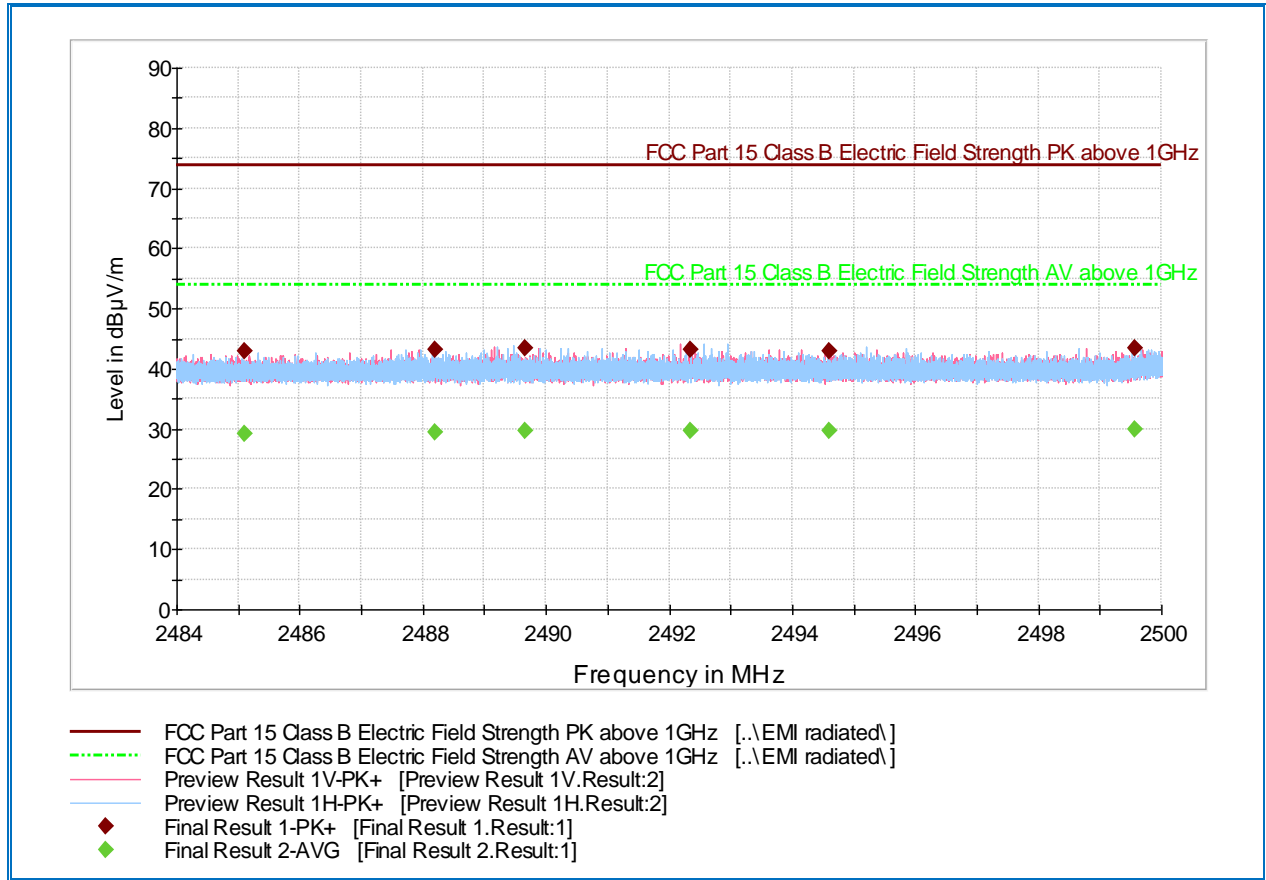

**Peak Data**

Frequency (MHz)	MaxPeak (dBµV/m)	Meas. Time (ms)	Bandwidth (kHz)	Height (cm)	Polarization	Azimuth (deg)	Corr. (dB)	Margin (dB)	Limit (dBµV/m)
2485.114667	42.8	1000.0	1000.000	126.1	H	76.0	-0.1	31.1	73.9
2488.193067	43.1	1000.0	1000.000	126.1	H	244.0	-0.1	30.8	73.9
2489.661867	43.4	1000.0	1000.000	126.1	H	244.0	-0.1	30.5	73.9
2492.355200	43.1	1000.0	1000.000	126.1	H	244.0	-0.1	30.8	73.9
2494.598933	43.0	1000.0	1000.000	115.8	H	244.0	-0.1	30.9	73.9
2499.565333	43.4	1000.0	1000.000	102.8	V	137.0	-0.1	30.5	73.9

**Average Data**

Frequency (MHz)	Average (dBµV/m)	Meas. Time (ms)	Bandwidth (kHz)	Height (cm)	Polarization	Azimuth (deg)	Corr. (dB)	Margin (dB)	Limit (dBµV/m)
2485.114667	29.1	1000.0	1000.000	126.1	H	76.0	-0.1	24.8	53.9
2488.193067	29.5	1000.0	1000.000	126.1	H	244.0	-0.1	24.4	53.9
2489.661867	29.6	1000.0	1000.000	126.1	H	244.0	-0.1	24.3	53.9
2492.355200	29.6	1000.0	1000.000	126.1	H	244.0	-0.1	24.3	53.9
2494.598933	29.6	1000.0	1000.000	115.8	H	244.0	-0.1	24.3	53.9
2499.565333	29.9	1000.0	1000.000	102.8	V	137.0	-0.1	24.0	53.9

**Test Notes:** 2.4GHz notch filter removed for this test.



**2.11 RECEIVER SPURIOUS EMISSIONS**

**2.11.1** Specification Reference  
RSS-Gen 7.1

**2.11.2** Standard Applicable

Spurious emissions from receivers shall not exceed the radiated limits shown in Table 2 below:

**Table 2: Receiver Radiated Limits**

Frequency (MHz)	Field Strength (microvolts/m at 3 metres)*
30-88	100
88-216	150
216-960	200
Above 960	500

\*Measurements for compliance with limits in the above table may be performed at distances other than 3 metres, in accordance with Section 6.5 of RSS-Gen.

**2.11.3 Equipment Under Test and Modification State**

Serial No: C10015220002 / Test Configuration B

**2.11.4 Date of Test/Initial of test personnel who performed the test**

July 17, 2015/NS

**2.11.5 Test Equipment Used**

The major items of test equipment used for the above tests are identified in Section 3.1.

**2.11.6 Environmental Conditions**

Test performed at TÜV SÜD America Inc. Rancho Bernardo facility

Ambient Temperature      24.6°C  
Relative Humidity          64.5%  
ATM Pressure                99.1 kPa

**2.11.7 Additional Observations**

- This is a radiated test. The spectrum was searched from 30MHz to the 3<sup>rd</sup> harmonic (up to 10<sup>th</sup> performed).
- Result identical to Section 2.9.10 and 2.9.11 of this test report.
- EUT in RX (Receive) mode configuration.



### **SECTION 3**

#### **TEST EQUIPMENT USED**



### 3.1 TEST EQUIPMENT USED

List of absolute measuring and other principal items of test equipment.

ID Number (SDGE/SDRB)	Test Equipment	Type	Serial Number	Manufacturer	Cal Date	Cal Due Date
<b>Antenna Conducted Port Setup</b>						
7569	Series Power Meter	N1911A P-	MY45100625	Agilent	05/27/15	05/27/16
7570	50MHz-18GHz Wideband Power Sensor	N1921A	MY45240588	Agilent	04/10/15	05/10/16
7611	Signal/Spectrum Analyzer	FSW26	102017	Rhode & Schwarz	03/25/15	03/25/16
1003	Signal Generator	SMR-40	1104.0002.40	Rhode & Schwarz	04/29/15	04/29/16
n/a	2 Way Resistive Power Divider (dc to 18 GHz)	DR285-18	50021	TRM Microwave	Verified by 1003 and 7611	
7562	Wideband Radio Comm. Tester	CMW-500		Rhode & Schwarz	10/09/13	10/09/15
<b>Radiated Test Setup</b>						
1002	Bilog Antenna	3142C	00058717	ETS-Lindgren	01/30/14	01/30/16
1040	EMI Test Receiver	ESIB40	100292	Rhode & Schwarz	08/29/14	08/29/15
1016	Pre-amplifier	PAM-0202	187	PAM	12/10/14	12/10/15
1051	Double-ridged waveguide horn antenna	3115	9408-4329	EMCO	02/28/14	02/28/16
1049	EMI Test Receiver	ESU	100133	Rhode & Schwarz	03/11/15	03/11/16
8628	Pre-amplifier	QLJ 01182835-JO	8986002	QuinStar Technologies Inc.	03/20/15	03/20/16
1153	High-frequency cable	SucoFlex 100 SX	N/A	Suhner	Verified by 1003 and 7611	
8543	High-frequency cable	Micropore 19057793	N/A	United Microwave Products	Verified by 1003 and 7611	
8849	High-frequency cable	SAC-26G-6.1	363	A.H.Systems	01/14/15	01/14/16
6815	2.4GHz Band Notch Filter	BRM50702	008	Micro-Tronics	Verified by 1003 and 7611	
<b>Miscellaneous</b>						
6792	Multimeter	3478A	2911A70964	Hewlett Packard	08/12/14	08/12/15
11312	Mini Environmental Quality Meter	850027	CF099-56010-340	Sper Scientific	04/09/15	04/09/16
	Test Software	EMC32	V8.53	Rhode & Schwarz	N/A	



### 3.2 MEASUREMENT UNCERTAINTY

For a 95% confidence level, the measurement uncertainties for defined systems are:

#### 3.2.1 Radiated Emission Measurements (Below 1GHz)

Contribution		Probability Distribution Type	Probability Distribution $x_i$	Standard Uncertainty $u(x_i)$	$[u(x_i)]^2$
1	Receiver/Spectrum Analyzer	Rectangular	0.45	0.26	0.07
2	Cables	Rectangular	0.50	0.29	0.08
3	Preamp	Rectangular	0.50	0.29	0.08
4	Antenna	Rectangular	0.75	0.43	0.19
5	Site	Rectangular	3.89	2.25	5.04
6	EUT Setup	Rectangular	1.00	0.58	0.33
Combined Uncertainty ( $u_c$ ):					2.41
Coverage Factor (k):					2
Expanded Uncertainty:					4.82

#### 3.2.2 Radiated Emission Measurements (Above 1GHz)

Contribution		Probability Distribution Type	Probability Distribution $x_i$	Standard Uncertainty $u(x_i)$	$[u(x_i)]^2$
1	Receiver/Spectrum Analyzer	Rectangular	0.57	0.33	0.11
2	Cables	Rectangular	0.70	0.40	0.16
3	Preamp	Rectangular	0.50	0.29	0.08
4	Antenna	Rectangular	0.37	0.21	0.05
5	Site	Rectangular	3.89	2.25	5.04
6	EUT Setup	Rectangular	1.00	0.58	0.33
Combined Uncertainty ( $u_c$ ):					2.40
Coverage Factor (k):					2
Expanded Uncertainty:					4.81

#### 3.2.3 Conducted Antenna Port Measurement

Contribution		Probability Distribution Type	Probability Distribution $x_i$	Standard Uncertainty $u(x_i)$	$[u(x_i)]^2$
1	Receiver/Spectrum Analyzer	Rectangular	0.57	0.33	0.11
2	Cables	Rectangular	0.50	0.29	0.08
3	EUT Setup	Rectangular	1.00	0.58	0.33
Combined Uncertainty ( $u_c$ ):					0.72
Coverage Factor (k):					2
Expanded Uncertainty:					1.45





## **SECTION 4**

### **DIAGRAM OF TEST SETUP**

#### 4.1 TEST SETUP DIAGRAM

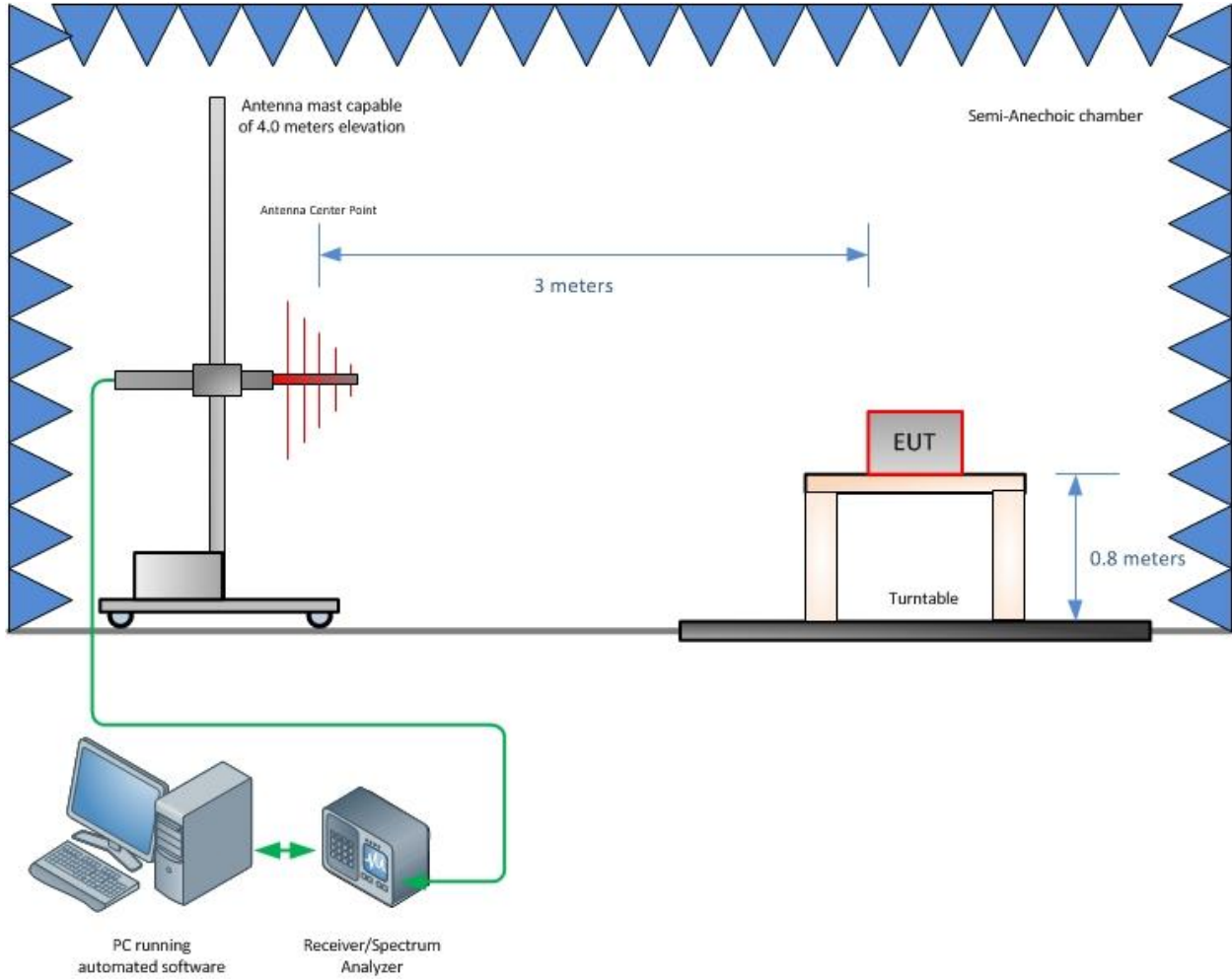

**Radiated Emission Test Setup (Below 1GHz)**

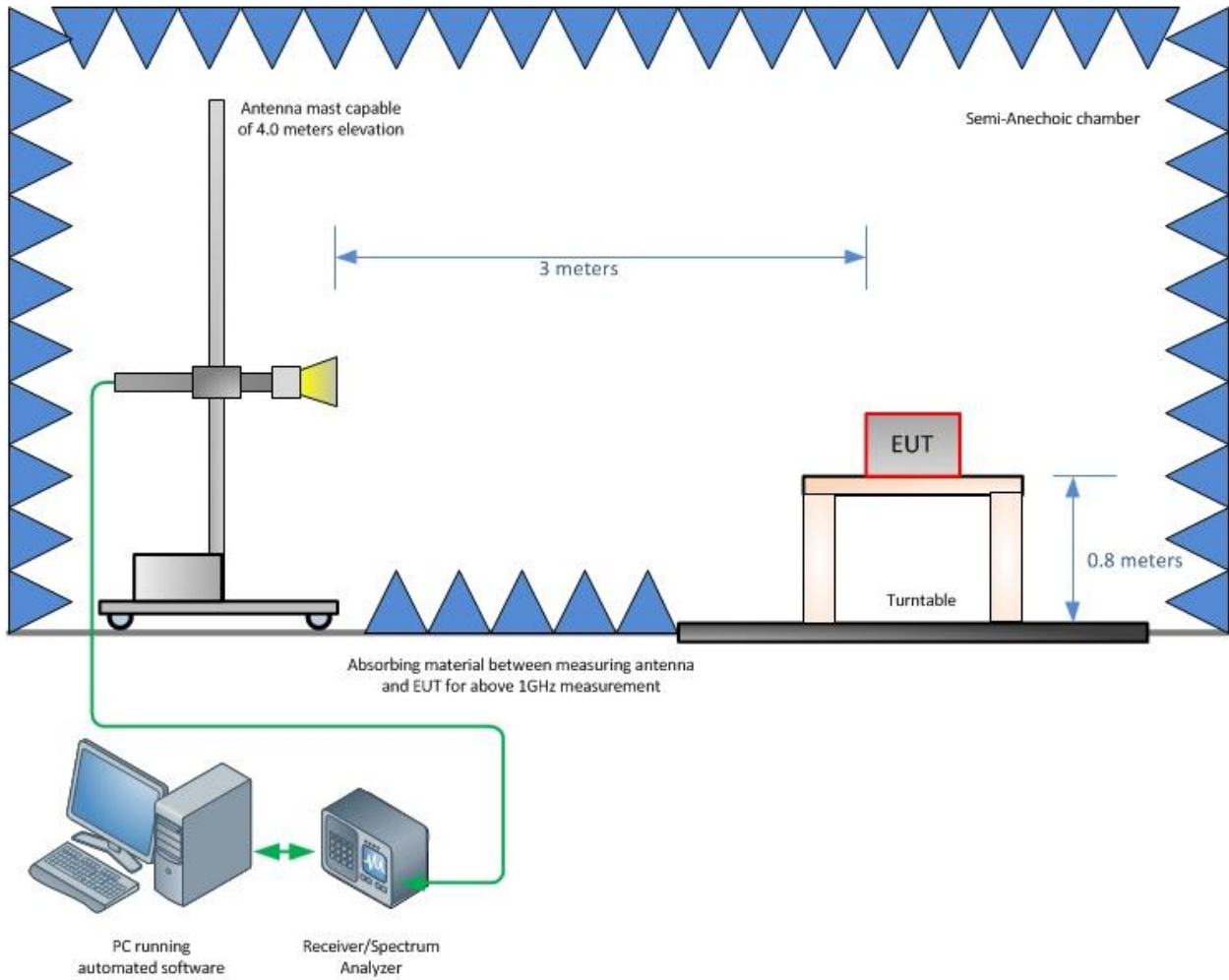

**Radiated Emission Test Setup (Above 1GHz)**



## SECTION 5

### ACCREDITATION, DISCLAIMERS AND COPYRIGHT



## 5.1 ACCREDITATION, DISCLAIMERS AND COPYRIGHT

TÜV SÜD America Inc.'s reports apply only to the specific sample tested under stated test conditions. It is the manufacturer's responsibility to assure the continued compliance of production units of this model. TÜV SÜD America, Inc. shall have no liability for any deductions, inferences or generalizations drawn by the client or others from TÜV SÜD America, Inc.'s issued reports.

This report is the confidential property of the client. As a mutual protection to our clients, the public and TÜV SÜD America, Inc., extracts from the test report shall not be reproduced, except in full without TÜV SÜD America, Inc.'s written approval.

This report must not be used to claim product certification, approval, or endorsement by A2LA, NIST, or any agency of the federal government.

TÜV SÜD America, Inc. and its professional staff hold government and professional organization certifications for AAMI, ACIL, AEA, ANSI, IEEE, A2LA, NIST and VCCI.



A2LA Cert. No. 2955.13

