

FCC Test Report (WLAN)

Report No.: RF180611E01C-1

FCC ID: 2ABLK-GS2026

Test Model: GS2026E

Received Date: Oct. 30, 2018

Test Date: Nov. 19 to Dec. 10, 2018

Issued Date: Mar. 14, 2019

Applicant: Calix Inc.

Address: 1035 N. McDowell Blvd. Petaluma, CA 94954 U.S.A.

Issued By: Bureau Veritas Consumer Products Services (H.K.) Ltd., Taoyuan Branch
Hsin Chu Laboratory

Lab Address: E-2, No.1, Li Hsin 1st Road, Hsinchu Science Park, Hsinchu City 300,
Taiwan R.O.C.

Test Location: E-2, No.1, Li Hsin 1st Road, Hsinchu Science Park, Hsinchu City 300,
Taiwan R.O.C.

**FCC Registration /
Designation Number:** 723255 / TW2022



This report is for your exclusive use. Any copying or replication of this report to or for any other person or entity, or use of our name or trademark, is permitted only with our prior written permission. This report sets forth our findings solely with respect to the test samples identified herein. The results set forth in this report are not indicative or representative of the quality or characteristics of the lot from which a test sample was taken or any similar or identical product specifically and expressly noted. Our report includes all of the tests requested by you and the results thereof based upon the information that you provided to us. You have 60 days from date of issuance of this report to notify us of any material error or omission caused by our negligence, provided, however, that such notice shall be in writing and shall specifically address the issue you wish to raise. A failure to raise such issue within the prescribed time shall constitute your unqualified acceptance of the completeness of this report, the tests conducted and the correctness of the report contents. Unless specific mention, the uncertainty of measurement has been explicitly taken into account to declare the compliance or non-compliance to the specification. The report must not be used by the client to claim product certification, approval, or endorsement by TAF or any government agencies.

Table of Contents

Release Control Record	4
1 Certificate of Conformity	5
2 Summary of Test Results	6
2.1 Measurement Uncertainty	6
2.2 Modification Record	6
3 General Information	7
3.1 General Description of EUT (WLAN)	7
3.2 Description of Test Modes	12
3.2.1 Test Mode Applicability and Tested Channel Detail	13
3.3 Duty Cycle of Test Signal	16
3.4 Description of Support Units	18
3.4.1 Configuration of System under Test	19
3.5 General Description of Applied Standard	20
4 Test Types and Results	21
4.1 Radiated Emission and Bandedge Measurement.....	21
4.1.1 Limits of Radiated Emission and Bandedge Measurement	21
4.1.2 Test Instruments	22
4.1.3 Test Procedure	24
4.1.4 Deviation from Test Standard	24
4.1.5 Test Setup.....	25
4.1.6 EUT Operating Condition	26
4.1.7 Test Results	27
4.2 Conducted Emission Measurement	48
4.2.1 Limits of Conducted Emission Measurement	48
4.2.2 Test Instruments	48
4.2.3 Test Procedure	49
4.2.4 Deviation from Test Standard	49
4.2.5 Test Setup.....	49
4.2.6 EUT Operating Condition	49
4.2.7 Test Results	50
4.3 Transmit Power Measurement	52
4.3.1 Limits of Transmit Power Measurement	52
4.3.2 Test Setup.....	52
4.3.3 Test Instruments	52
4.3.4 Test Procedure	52
4.3.5 Deviation from Test Standard	52
4.3.6 EUT Operating Condition	52
4.3.7 Test Results	53
4.4 Occupied Bandwidth Measurement	68
4.4.1 Test Setup.....	68
4.4.2 Test Instruments	68
4.4.3 Test Procedure	68
4.4.4 Test Results	69
4.5 Peak Power Spectral Density Measurement	81
4.5.1 Limits of Peak Power Spectral Density Measurement	81
4.5.2 Test Setup.....	81
4.5.3 Test Instruments	81
4.5.4 Test Procedure	81
4.5.5 Deviation from Test Standard	82
4.5.6 EUT Operating Condition	82
4.5.7 Test Results	83
4.6 Frequency Stability Measurement	100
4.6.1 Limits of Frequency Stability Measurement	100

4.6.2	Test Setup.....	100
4.6.3	Test Instruments	100
4.6.4	Test Procedure	100
4.6.5	Deviation from Test Standard	100
4.6.6	EUT Operating Condition	100
4.6.7	Test Results	101
4.7	6dB Bandwidth Measurement.....	102
4.7.1	Limits of 6dB Bandwidth Measurement.....	102
4.7.2	Test Setup.....	102
4.7.3	Test Instruments	102
4.7.4	Test Procedure	102
4.7.5	Deviation from Test Standard	102
4.7.6	EUT Operating Condition	102
4.7.7	Test Results	103
5	Pictures of Test Arrangements.....	105
	Annex A- Radiated Out of Band Emission (OOBE) Measurement (For U-NII-3 band).....	106
	Appendix – Information of the Testing Laboratories	110

Release Control Record

Issue No.	Description	Date Issued
RF180611E01C-1	Original release.	Mar. 14, 2019

1 Certificate of Conformity

Product: GigaSpire

Brand: Calix

Test Model: GS2026E

Sample Status: MASS-PRODUCTION

Applicant: Calix Inc.

Test Date: Nov. 19 to Dec. 10, 2018

Standard: 47 CFR FCC Part 15, Subpart E (Section 15.407)
ANSI C63.10: 2013

The above equipment has been tested by **Bureau Veritas Consumer Products Services (H.K.) Ltd., Taoyuan Branch**, and found compliance with the requirement of the above standards. The test record, data evaluation & Equipment Under Test (EUT) configurations represented herein are true and accurate accounts of the measurements of the sample's EMC characteristics under the conditions specified in this report.

Prepared by : Mary Ko , **Date:** Mar. 14, 2019
Mary Ko / Specialist

Approved by : May Chen , **Date:** Mar. 14, 2019
May Chen / Manager

2 Summary of Test Results

47 CFR FCC Part 15, Subpart E (Section 15.407)

FCC Clause	Test Item	Result	Remarks
15.407(b)(6)	AC Power Conducted Emissions	Pass	Meet the requirement of limit. Minimum passing margin is -9.56dB at 0.40000MHz.
15.407(b) (1/2/3/4(i/ii)/6)	Radiated Emissions & Band Edge Measurement*	Pass	Meet the requirement of limit. Minimum passing margin is -3.4dB at 37.76MHz.
15.407(a)(1/2/3)	Max Average Transmit Power	Pass	Meet the requirement of limit.
---	Occupied Bandwidth Measurement	-	Reference only.
15.407(a)(1/2/3)	Peak Power Spectral Density	Pass	Meet the requirement of limit.
15.407(e)	6dB bandwidth	Pass	Meet the requirement of limit. (U-NII-3 Band only)
15.407(g)	Frequency Stability	Pass	Meet the requirement of limit.
15.203	Antenna Requirement	Pass	Antenna connector is i-pex(MHF) not a standard connector.

*For U-NII-3 band compliance with rule part 15.407(b)(4)(i), the OOB test plots were recorded in Annex A.

2.1 Measurement Uncertainty

Where relevant, the following measurement uncertainty levels have been estimated for tests performed on the EUT as specified in CISPR 16-4-2:

Measurement	Frequency	Expanded Uncertainty (k=2) (±)
Conducted Emissions at mains ports	150kHz ~ 30MHz	1.84 dB
Radiated Emissions up to 1 GHz	30MHz ~ 1GHz	5.53 dB
Radiated Emissions above 1 GHz	1GHz ~ 6GHz	5.08 dB
	6GHz ~ 18GHz	4.98 dB
	18GHz ~ 40GHz	5.19 dB

2.2 Modification Record

There were no modifications required for compliance.

3 General Information

3.1 General Description of EUT (WLAN)

Product	GigaSpire
Brand	Calix
Test Model	GS2026E
Status of EUT	MASS-PRODUCTION
Power Supply Rating	12Vdc from adapter
Modulation Type	CCK, DQPSK, DBPSK for DSSS 64QAM, 16QAM, QPSK, BPSK for OFDM 256QAM for OFDM in 11ac mode and VHT (20/40) mode in 2.4GHz 1024QAM for OFDMA in 11ax HE mode
Modulation Technology	DSSS, OFDM, OFDMA
Transfer Rate	802.11b: up to 11Mbps 802.11a/g: up to 54Mbps 802.11n: up to 600Mbps 802.11ac: up to 3466.7Mbps 802.11ax: up to 4803.9Mbps
Operating Frequency	2.4GHz: 2.412 ~ 2.462GHz 5GHz: 5.18GHz ~ 5.24GHz, 5.745GHz ~ 5.825GHz
Number of Channel	2.4GHz: 802.11b, 802.11g, 802.11n (HT20), VHT20, 802.11ax (HE20): 11 802.11n (HT40), VHT40, 802.11ax (HE40): 7 5GHz: 802.11a, 802.11n (HT20), 802.11ac (VHT20), 802.11ax (HE20): 9 802.11n (HT40), 802.11ac (VHT40), 802.11ax (HE40): 4 802.11ac (VHT80), 802.11ax (HE80): 2 802.11ac (VHT80+80), 802.11ax (HE80+80): 1 set
Output Power	2.4GHz Non-Beamforming Mode: 773.819mW Beamforming Mode: 693.033mW 5.18 ~ 5.24GHz (Master) Non-Beamforming Mode: 419.096mW Beamforming Mode: 419.096mW 5.18 ~ 5.24GHz (Client) Non-Beamforming Mode: 107.002mW Beamforming Mode: 107.002mW 5.745 ~ 5.825GHz Non-Beamforming Mode: 366.45mW Beamforming Mode: 366.45mW
Antenna Type	Refer to Note
Antenna Connector	Refer to Note
Accessory Device	Adapter x 1
Data Cable Supplied	NA

Note:

- This report is prepared for FCC class II change. The difference compared with the Report No.: RF180611E01-1 design changed is as the following:
 - ◆ Upgrade SW for adding client mode (U-NII-1 & U-NII-3 bands), adjustment spurious emission performance and enable 802.11n/an/ax beamforming mode characteristic (except 802.11a/b/g modulation type).
- According to above condition, all test items need to be performed. And all data were verified to meet the requirements.
- There are WLAN, Bluetooth, Zigbee and Z-wave technology used for the EUT. The EUT has below radios as following table:

Radio 1	Radio 2	Radio 3	Radio 4	Radio 5
WLAN - 4TX (2.4GHz+5GHz)	WLAN - 4TX (5GHz)	Bluetooth	Zigbee	Z-wave

Note: For WLAN- 5GHz based on Radio 1 + 2 operating at same time.

- Simultaneously transmission condition.

Condition	Technology				
1	WLAN 2.4GHz	WLAN 5GHz	Bluetooth	Zigbee	Z-wave

Note: The emission of the simultaneous operation has been evaluated and no non-compliance was found.

- The EUT must be supplied with a power adapter as following table:

Brand	Model No.	Spec.
Frecom	F60-120500SPA	Input: 100-240Vac, 1.6A, 50/60Hz AC input cable: Unshielded, 1.0m Output: 12V, 5A DC output cable: Unshielded, 1.5m
		Input: 100-240Vac, 1.6A, 50/60Hz AC input cable: Unshielded, 1.5m Output: 12V, 5A DC output cable: Unshielded, 1.5m

Note: In their original, from the above spec., the radiated emissions worse case was found in **AC input cable: Unshielded, 1.0m**. Therefore only the test data of the mode was recorded in this report.

- The antennas provided to the EUT, please refer to the following table:

WLAN Directional gain table			
Frequency range (GHz)	Directional Antenna Gain (dBi)	Antenna Type	Antenna Connector
2.4 ~ 2.4835	7.41	Dipole	i-pex(MHF)
5.18 ~ 5.24	9.7		
5.26 ~ 5.32	9.9		
5.50 ~ 5.70	9.83		
5.745 ~ 5.825	10.27		
Bluetooth antenna spec.			
Antenna Net Gain (dBi)	Frequency range (GHz)	Antenna Type	Antenna Connector
3.04	2.4~2.5	PIFA	None
Zigbee antenna spec.			
Antenna Net Gain (dBi)	Frequency range (GHz)	Antenna Type	Antenna Connector
3.29	2.4~2.5	MONOPOLE	None
Z-wave antenna spec.			
Antenna Net Gain (dBi)	Frequency range (MHz)	Antenna Type	Antenna Connector
2.76	850~920	PIFA	None

Note: More detailed information, please refer to operating description.

7. The EUT incorporates a MIMO function:

2.4GHz Band			
MODULATION MODE	DATA RATE (MCS)	TX & RX CONFIGURATION	
802.11b	1 ~ 11Mbps	4TX	4RX
802.11g	6 ~ 54Mbps	4TX	4RX
802.11n (HT20)	MCS 0~7	4TX	4RX
	MCS 8~15	4TX	4RX
	MCS 16~23	4TX	4RX
	MCS 24~31	4TX	4RX
802.11n (HT40)	MCS 0~7	4TX	4RX
	MCS 8~15	4TX	4RX
	MCS 16~23	4TX	4RX
	MCS 24~31	4TX	4RX
VHT20	MCS0~8 Nss=1	4TX	4RX
	MCS0~8 Nss=2	4TX	4RX
	MCS0~9 Nss=3	4TX	4RX
	MCS0~8 Nss=4	4TX	4RX
VHT40	MCS0~9 Nss=1	4TX	4RX
	MCS0~9 Nss=2	4TX	4RX
	MCS0~9 Nss=3	4TX	4RX
	MCS0~9 Nss=4	4TX	4RX
802.11ax (HE20)	MCS0~11 Nss=1	4TX	4RX
	MCS0~11 Nss=2	4TX	4RX
	MCS0~11 Nss=3	4TX	4RX
	MCS0~11 Nss=4	4TX	4RX
802.11ax (HE40)	MCS0~11 Nss=1	4TX	4RX
	MCS0~11 Nss=2	4TX	4RX
	MCS0~11 Nss=3	4TX	4RX
	MCS0~11 Nss=4	4TX	4RX
5GHz Band (Radio 1 + 2)			
MODULATION MODE	DATA RATE (MCS)	TX & RX CONFIGURATION	
802.11a	6 ~ 54Mbps	8TX	8RX
802.11n (HT20)	MCS 0~7	8TX	8RX
	MCS 8~15	8TX	8RX
	MCS 16~23	8TX	8RX
	MCS 24~31	8TX	8RX
802.11n (HT40)	MCS 0~7	8TX	8RX
	MCS 8~15	8TX	8RX
	MCS 16~23	8TX	8RX
	MCS 24~31	8TX	8RX
802.11ac (VHT20)	MCS0~8 Nss=1	8TX	8RX
	MCS0~8 Nss=2	8TX	8RX
	MCS0~9 Nss=3	8TX	8RX
	MCS0~8 Nss=4	8TX	8RX
	MCS0~8 Nss=5	8TX	8RX
	MCS0~9 Nss=6	8TX	8RX
	MCS0~8 Nss=7	8TX	8RX
	MCS0~8 Nss=8	8TX	8RX

802.11ac (VHT40)	MCS0~9 Nss=1	8TX	8RX
	MCS0~9 Nss=2	8TX	8RX
	MCS0~9 Nss=3	8TX	8RX
	MCS0~9 Nss=4	8TX	8RX
	MCS0~9 Nss=5	8TX	8RX
	MCS0~9 Nss=6	8TX	8RX
	MCS0~9 Nss=7	8TX	8RX
	MCS0~9 Nss=8	8TX	8RX
802.11ac (VHT80)	MCS0~9 Nss=1	8TX	8RX
	MCS0~9 Nss=2	8TX	8RX
	MCS0~9 Nss=3	8TX	8RX
	MCS0~9 Nss=4	8TX	8RX
	MCS0~9 Nss=5	8TX	8RX
	MCS0~8 Nss=6	8TX	8RX
	MCS 0~9 Nss=7	8TX	8RX
MCS0~9 Nss=8	8TX	8RX	
802.11ac (VHT80+80)	MCS0~9 Nss=1	4TX+4TX	4RX+4RX
	MCS0~9 Nss=2	4TX+4TX	4RX+4RX
	MCS0~9 Nss=3	4TX+4TX	4RX+4RX
	MCS0~9 Nss=4	4TX+4TX	4RX+4RX
802.11ax (HE20)	MCS0~11 Nss=1	8TX	8RX
	MCS0~11 Nss=2	8TX	8RX
	MCS0~11 Nss=3	8TX	8RX
	MCS0~11 Nss=4	8TX	8RX
	MCS0~11 Nss=5	8TX	8RX
	MCS0~11 Nss=6	8TX	8RX
	MCS0~11 Nss=7	8TX	8RX
	MCS0~11 Nss=8	8TX	8RX
802.11ax (HE40)	MCS0~11 Nss=1	8TX	8RX
	MCS0~11 Nss=2	8TX	8RX
	MCS0~11 Nss=3	8TX	8RX
	MCS0~11 Nss=4	8TX	8RX
	MCS0~11 Nss=5	8TX	8RX
	MCS0~11 Nss=6	8TX	8RX
	MCS0~11 Nss=7	8TX	8RX
	MCS0~11 Nss=8	8TX	8RX
802.11ax (HE80)	MCS0~11 Nss=1	8TX	8RX
	MCS0~11 Nss=2	8TX	8RX
	MCS0~11 Nss=3	8TX	8RX
	MCS0~11 Nss=4	8TX	8RX
	MCS0~11 Nss=5	8TX	8RX
	MCS0~11 Nss=6	8TX	8RX
	MCS0~11 Nss=7	8TX	8RX
	MCS0~11 Nss=8	8TX	8RX
802.11ax (HE80+80)	MCS0~11 Nss=1	4TX+4TX	4RX+4RX
	MCS0~11 Nss=2	4TX+4TX	4RX+4RX
	MCS0~11 Nss=3	4TX+4TX	4RX+4RX
	MCS0~11 Nss=4	4TX+4TX	4RX+4RX

Note:

1. All of modulation mode support beamforming function except 802.11a/b/g modulation mode.
 2. The EUT support Beamforming and non-beamforming mode, therefore both mode were investigated and the worst case scenario was identified. The worst case data were presented in test report.
 3. The modulation and bandwidth are similar for 802.11n mode for 20MHz (40MHz) and 802.11ac/ax mode for 20MHz (40MHz/80MHz), therefore investigated worst case to representative mode in test report. (Final test mode refer section 3.2.1)
-
8. This device can support different category application which switched by access point mode and client mode by software.
 9. The above EUT information is declared by manufacturer and for more detailed features description, please refers to the manufacturer's specifications or user's manual.

3.2 Description of Test Modes

FOR 5180 ~ 5240MHz

4 channels are provided for 802.11a, 802.11n (HT20), 802.11ac (VHT20), 802.11ax (HE20):

Channel	Frequency	Channel	Frequency
36	5180 MHz	44	5220 MHz
40	5200 MHz	48	5240 MHz

2 channels are provided for 802.11n (HT40), 802.11ac (VHT40), 802.11ax (HE40):

Channel	Frequency	Channel	Frequency
38	5190 MHz	46	5230 MHz

1 channel is provided for 802.11ac (VHT80), 802.11ax (HE80):

Channel	Frequency
42	5210 MHz

FOR 5745 ~ 5825MHz

5 channels are provided for 802.11a, 802.11n (HT20), 802.11ac (VHT20), 802.11ax (HE20):

Channel	Frequency	Channel	Frequency
149	5745 MHz	161	5805 MHz
153	5765 MHz	165	5825 MHz
157	5785 MHz		

2 channels are provided for 802.11n (HT40), 802.11ac (VHT40), 802.11ax (HE40):

Channel	Frequency	Channel	Frequency
151	5755 MHz	159	5795 MHz

1 channel is provided for 802.11ac (VHT80), 802.11ax (HE80):

Channel	Frequency
155	5775 MHz

For simultaneous transmission:

1 set is provided for 802.11ac (VHT80+80), 802.11ax (HE80+80):

Channel	Frequency
42+155	5210 MHz + 5775 MHz

Note: The transmission is for noncontiguous transmission using two nonadjacent 80MHz channels.

3.2.1 Test Mode Applicability and Tested Channel Detail

EUT Configure Mode	Applicable To				Description
	RE≥1G	RE<1G	PLC	APCM	
-	√	√	√	√	-

Where **RE≥1G**: Radiated Emission above 1GHz **RE<1G**: Radiated Emission below 1GHz
PLC: Power Line Conducted Emission **APCM**: Antenna Port Conducted Measurement

Radiated Emission Test (Above 1GHz):

- Pre-Scan has been conducted to determine the worst-case mode from all possible combinations between available modulations, data rates and antenna ports (if EUT with antenna diversity architecture).
- Following channel(s) was (were) selected for the final test as listed below.

Non-Beamforming Mode						
Mode	FREQ. Band (MHz)	Available Channel	Tested Channel	Modulation Technology	Modulation Type	Data Rate Parameter
802.11a	5180-5240	36 to 48	36, 40, 48	OFDM	BPSK	6Mb/s
802.11ax (HE20)		36 to 48	36, 40, 48	OFDMA	BPSK	MCS0
802.11ax (HE40)		38 to 46	38, 46	OFDMA	BPSK	MCS0
802.11ax (HE80)		42	42	OFDMA	BPSK	MCS0
802.11a	5745-5825	149 to 165	149, 157, 165	OFDM	BPSK	6Mb/s
802.11ax (HE20)		149 to 165	149, 157, 165	OFDMA	BPSK	MCS0
802.11ax (HE40)		151 to 159	151, 159	OFDMA	BPSK	MCS0
802.11ax (HE80)		155	155	OFDMA	BPSK	MCS0
802.11ax (HE80+80)	5180-5240, 5745-5825	42 + 155	42 + 155	OFDMA	BPSK	MCS0

Radiated Emission Test (Below 1GHz):

- Pre-Scan has been conducted to determine the worst-case mode from all possible combinations between available modulations, data rates and antenna ports (if EUT with antenna diversity architecture).
- Following channel(s) was (were) selected for the final test as listed below.

Non-Beamforming Mode						
Mode	FREQ. Band (MHz)	Available Channel	Tested Channel	Modulation Technology	Modulation Type	Data Rate Parameter
802.11ax (HE20)	5180-5240 5745-5825	36 to 48 149 to 165	48	OFDMA	BPSK	MCS0

Power Line Conducted Emission Test:

- Pre-Scan has been conducted to determine the worst-case mode from all possible combinations between available modulations, data rates and antenna ports (if EUT with antenna diversity architecture).
- Following channel(s) was (were) selected for the final test as listed below.

Non-Beamforming Mode						
Mode	FREQ. Band (MHz)	Available Channel	Tested Channel	Modulation Technology	Modulation Type	Data Rate Parameter
802.11ax (HE20)	5180-5240 5745-5825	36 to 48 149 to 165	48	OFDMA	BPSK	MCS0

Antenna Port Conducted Measurement:

- This item includes all test value of each mode, but only includes spectrum plot of worst value of each mode.
- Pre-Scan has been conducted to determine the worst-case mode from all possible combinations between available modulations, data rates and antenna ports (if EUT with antenna diversity architecture).
- Following channel(s) was (were) selected for the final test as listed below.

Non-Beamforming Mode						
Mode	FREQ. Band (MHz)	Available Channel	Tested Channel	Modulation Technology	Modulation Type	Data Rate Parameter
802.11a	5180-5240	36 to 48	36, 40, 48	OFDM	BPSK	6Mb/s
802.11ac (VHT20)		36 to 48	36, 40, 48	OFDM	BPSK	MCS0
802.11ac (VHT40)		38 to 46	38, 46	OFDM	BPSK	MCS0
802.11ac (VHT80)		42	42	OFDM	BPSK	MCS0
802.11ax (HE20)		36 to 48	36, 40, 48	OFDMA	BPSK	MCS0
802.11ax (HE40)		38 to 46	38, 46	OFDMA	BPSK	MCS0
802.11ax (HE80)		42	42	OFDMA	BPSK	MCS0
802.11a	5745-5825	149 to 165	149, 157, 165	OFDM	BPSK	6Mb/s
802.11ac (VHT20)		149 to 165	149, 157, 165	OFDM	BPSK	MCS0
802.11ac (VHT40)		151 to 159	151, 159	OFDM	BPSK	MCS0
802.11ac (VHT80)		155	155	OFDM	BPSK	MCS0
802.11ax (HE20)		149 to 165	149, 157, 165	OFDMA	BPSK	MCS0
802.11ax (HE40)		151 to 159	151, 159	OFDMA	BPSK	MCS0
802.11ax (HE80)		155	155	OFDMA	BPSK	MCS0
802.11ac (VHT80+80)	5180-5240, 5745-5825	42 + 155	42 + 155	OFDM	BPSK	MCS0
802.11ax (HE80+80)	5180-5240, 5745-5825	42 + 155	42 + 155	OFDMA	BPSK	MCS0
Beamforming Mode (output only)						
Mode	FREQ. Band (MHz)	Available Channel	Tested Channel	Modulation Technology	Modulation Type	Data Rate Parameter
802.11ac (VHT20)	5180-5240	36 to 48	36, 40, 48	OFDM	BPSK	MCS0
802.11ac (VHT40)		38 to 46	38, 46	OFDM	BPSK	MCS0
802.11ac (VHT80)		42	42	OFDM	BPSK	MCS0
802.11ax (HE20)		36 to 48	36, 40, 48	OFDMA	BPSK	MCS0
802.11ax (HE40)		38 to 46	38, 46	OFDMA	BPSK	MCS0
802.11ax (HE80)		42	42	OFDMA	BPSK	MCS0
802.11ac (VHT20)	5745-5825	149 to 165	149, 157, 165	OFDM	BPSK	MCS0
802.11ac (VHT40)		151 to 159	151, 159	OFDM	BPSK	MCS0
802.11ac (VHT80)		155	155	OFDM	BPSK	MCS0
802.11ax (HE20)		149 to 165	149, 157, 165	OFDMA	BPSK	MCS0
802.11ax (HE40)		151 to 159	151, 159	OFDMA	BPSK	MCS0
802.11ax (HE80)		155	155	OFDMA	BPSK	MCS0
802.11ac (VHT80+80)	5180-5240, 5745-5825	42 + 155	42 + 155	OFDM	BPSK	MCS0
802.11ax (HE80+80)	5180-5240, 5745-5825	42 + 155	42 + 155	OFDMA	BPSK	MCS0

Test Condition:

Applicable To	Environmental Conditions	Input Power	Tested By
RE \geq 1G	23deg. C, 67%RH	120Vac, 60Hz	Rey Chen
	23deg. C, 70%RH	120Vac, 60Hz	Steven Chiang
RE $<$ 1G	23deg. C, 68%RH	120Vac, 60Hz	Frank Chuang
PLC	24deg. C, 76%RH	120Vac, 60Hz	Andy Ho
APCM	25deg. C, 60%RH	120Vac, 60Hz	Jyunchun Lin

3.3 Duty Cycle of Test Signal

If duty cycle of test signal is < 98%, duty factor shall be considered.

802.11a: Duty cycle = 1.432 ms/1.615 ms = 0.887, Duty factor = $10 * \log(1/0.887) = 0.52$

802.11ac (VHT20): Duty cycle = 5.42 ms/5.63 ms = 0.963, Duty factor = $10 * \log(1/0.963) = 0.17$

802.11ac (VHT40): Duty cycle = 5.42 ms/5.62 ms = 0.964, Duty factor = $10 * \log(1/0.964) = 0.16$

802.11ac (VHT80): Duty cycle = 5.418 ms/5.618 ms = 0.964, Duty factor = $10 * \log(1/0.964) = 0.16$

802.11ac (VHT80+80): Duty cycle = 5.422/5.627 = 0.964, Duty factor = $10 * \log(1/0.964) = 0.16$

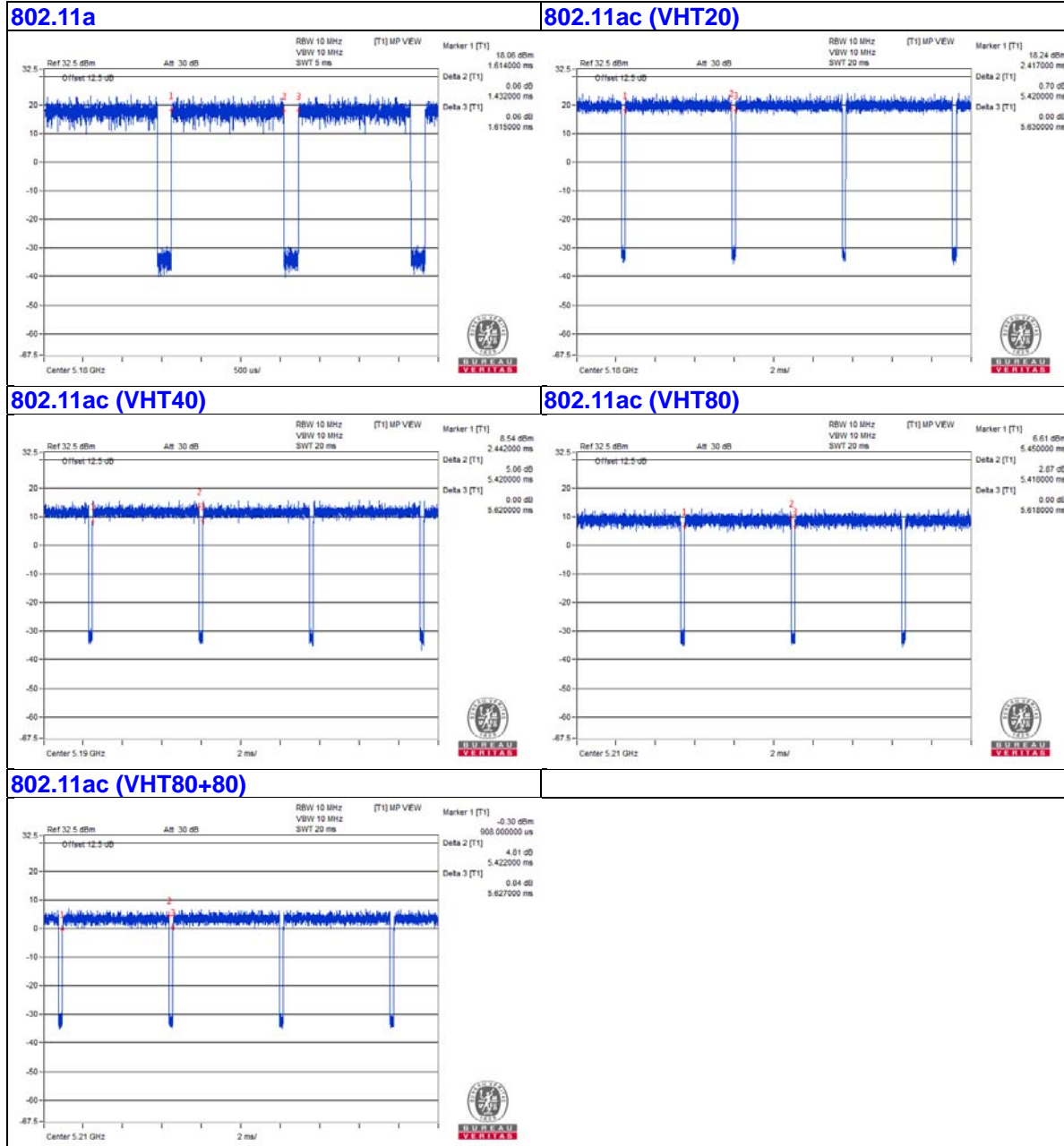

802.11ax (HE20): Duty cycle = 5.443 ms/5.65 ms = 0.963, Duty factor = $10 * \log(1/0.963) = 0.16$
802.11ax (HE40): Duty cycle = 5.438 ms/5.668 ms = 0.959, Duty factor = $10 * \log(1/0.959) = 0.18$
802.11ax (HE80): Duty cycle = 5.438 ms/5.638 ms = 0.965, Duty factor = $10 * \log(1/0.965) = 0.16$
802.11ax (HE80+80): Duty cycle = 5.437/5.644 = 0.963, Duty factor = $10 * \log(1/0.963) = 0.16$

802.11ax (HE20)

802.11ax (HE40)

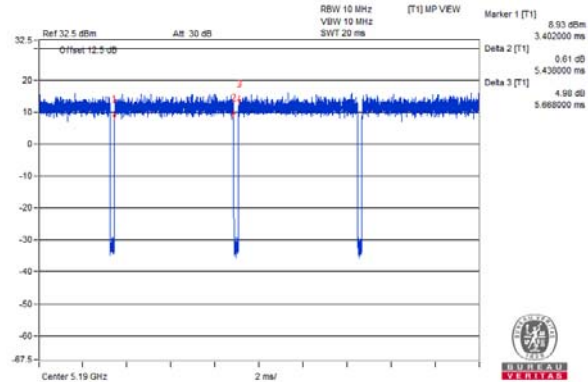
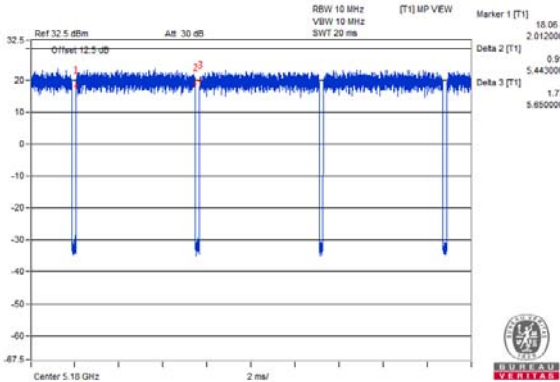

802.11ax (HE80)

802.11ax (HE80+80)

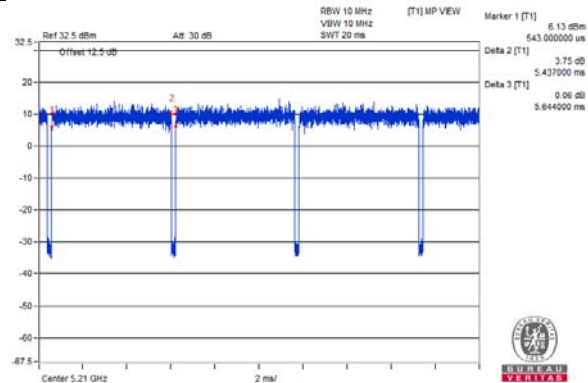
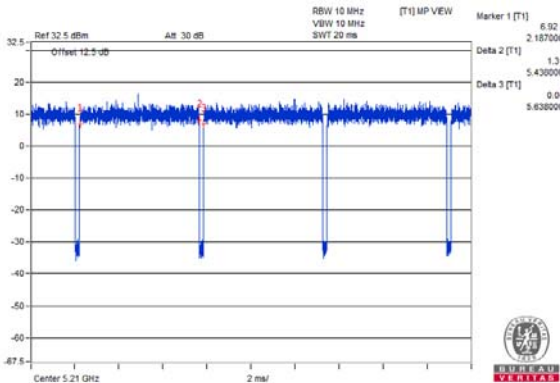

3.4 Description of Support Units

The EUT has been tested as an independent unit together with other necessary accessories or support units. The following support units or accessories were used to form a representative test configuration during the tests.

ID	Product	Brand	Model No.	Serial No.	FCC ID	Remarks
A.	Laptop	DELL	E5430	HYV4VY1	FCC DoC	Provided by Lab
B.	Laptop	DELL	E6420	B92T3R1	FCC DoC	Provided by Lab
C.	Earphone	Apple	NA	NA	NA	Provided by Lab
D.	USB 3.0 Disk	Transcend	16GB	NA	NA	Provided by Lab

Note:

1. All power cords of the above support units are non-shielded (1.8m).

ID	Descriptions	Qty.	Length (m)	Shielding (Yes/No)	Cores (Qty.)	Remarks
1.	DC Cable	1	1.5	No	0	Supplied by client
2.	AC Cable	1	1.0	No	0	Supplied by client
3.	RJ-45 Cable	1	10	No	0	Provided by Lab
4.	RJ-45 Cable	1	10	No	0	Provided by Lab
5.	Audio Cable	1	1.2	No	0	Provided by Lab

3.4.1 Configuration of System under Test

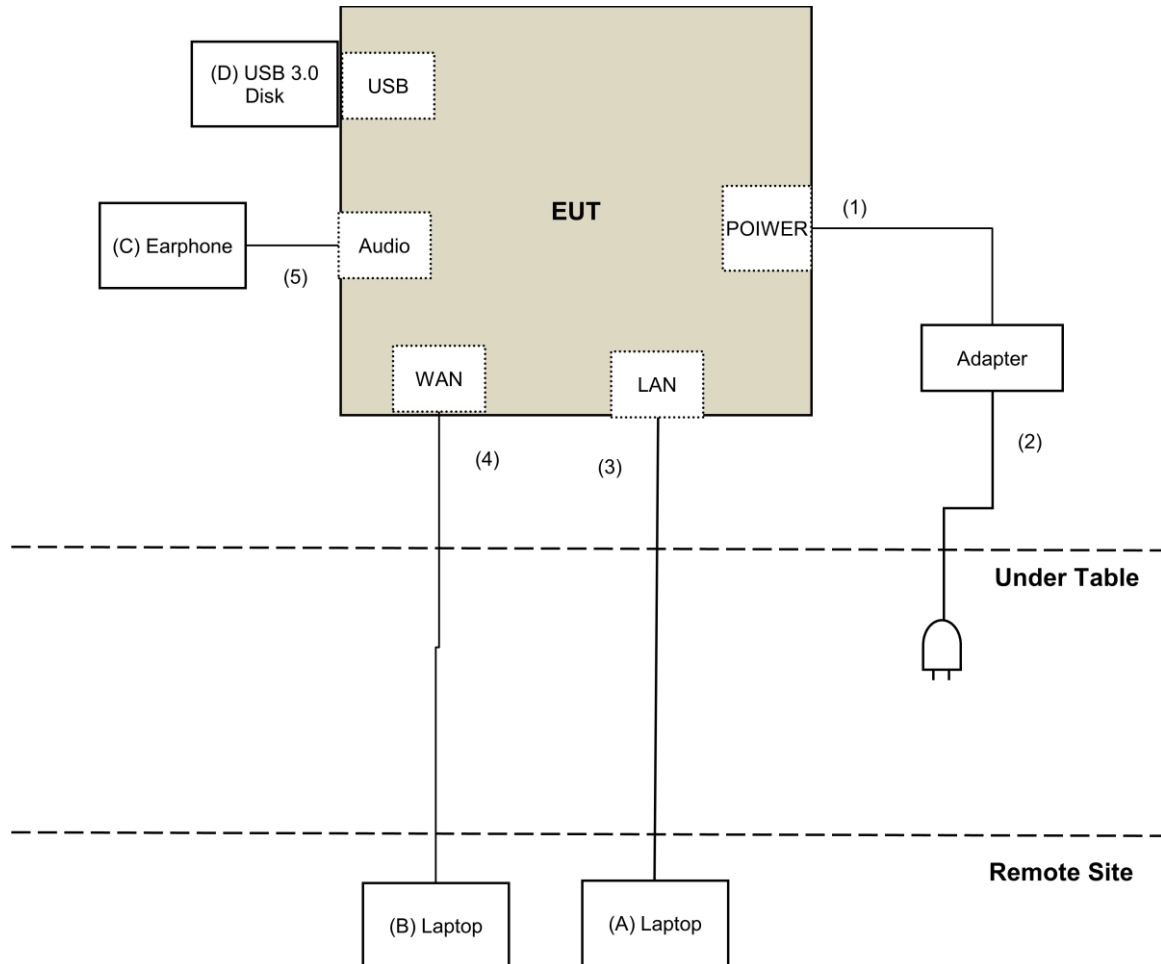

3.5 General Description of Applied Standard

The EUT is a RF Product. According to the specifications of the manufacturer, it must comply with the requirements of the following standards:

FCC Part 15, Subpart E (15.407)

KDB 789033 D02 General UNII Test Procedure New Rules v02r01

KDB 662911 D01 Multiple Transmitter Output v02r01

ANSI C63.10-2013

All test items have been performed and recorded as per the above standards.

4 Test Types and Results

4.1 Radiated Emission and Bandedge Measurement

4.1.1 Limits of Radiated Emission and Bandedge Measurement

Radiated emissions which fall in the restricted bands must comply with the radiated emission limits specified as below table.

Frequencies (MHz)	Field Strength (microvolts/meter)	Measurement Distance (meters)
0.009 ~ 0.490	2400/F(kHz)	300
0.490 ~ 1.705	24000/F(kHz)	30
1.705 ~ 30.0	30	30
30 ~ 88	100	3
88 ~ 216	150	3
216 ~ 960	200	3
Above 960	500	3

NOTE:

- The lower limit shall apply at the transition frequencies.
- Emission level (dBuV/m) = 20 log Emission level (uV/m).
- For frequencies above 1000MHz, the field strength limits are based on average detector, however, the peak field strength of any emission shall not exceed the maximum permitted average limits, specified above by more than 20dB under any condition of modulation.

Limits of unwanted emission out of the restricted bands

Applicable To		Limit	
789033 D02 General UNII Test Procedure New Rules v02r01		Field Strength at 3m	
		PK:74 (dBuV/m)	AV:54 (dBuV/m)
Frequency Band	Applicable To	EIRP Limit	Equivalent Field Strength at 3m
5150~5250 MHz	15.407(b)(1)	PK:-27 (dBm/MHz)	PK:68.2(dBμV/m)
5250~5350 MHz	15.407(b)(2)		
5470~5725 MHz	15.407(b)(3)		
5725~5850 MHz	<input checked="" type="checkbox"/> 15.407(b)(4)(i)	PK:-27 (dBm/MHz) ^{*1} PK:10 (dBm/MHz) ^{*2} PK:15.6 (dBm/MHz) ^{*3} PK:27 (dBm/MHz) ^{*4}	PK: 68.2(dBμV/m) ^{*1} PK:105.2 (dBμV/m) ^{*2} PK: 110.8(dBμV/m) ^{*3} PK:122.2 (dBμV/m) ^{*4}
	<input type="checkbox"/> 15.407(b)(4)(ii)	Emission limits in section 15.247(d)	
*1 beyond 75 MHz or more above of the band edge.		*2 below the band edge increasing linearly to 10 dBm/MHz at 25 MHz above.	
*3 below the band edge increasing linearly to a level of 15.6 dBm/MHz at 5 MHz above.		*4 from 5 MHz above or below the band edge increasing linearly to a level of 27 dBm/MHz at the band edge.	

Note:

The following formula is used to convert the equipment isotropic radiated power (eirp) to field strength:

$$E = \frac{1000000\sqrt{30P}}{3} \mu\text{V/m, where P is the eirp (Watts).}$$

4.1.2 Test Instruments

For radiated emission test (Above 1GHz test):

DESCRIPTION & MANUFACTURER	MODEL NO.	SERIAL NO.	CALIBRATED DATE	CALIBRATED UNTIL
Test Receiver Agilent	N9038A	MY50010156	July 12, 2018	July 11, 2019
Horn_Antenna SCHWARZBECK	BBHA9120-D	9120D-406	Dec. 12, 2017	Dec. 11, 2018
Pre-Amplifier EMCI	EMC12630SE	980384	Jan. 29, 2018	Jan. 28, 2019
RF Cable	EMC104-SM-SM-1200	160922	Jan. 29, 2018	Jan. 28, 2019
RF Cable	EMC104-SM-SM-2000	150317	Jan. 29, 2018	Jan. 28, 2019
RF Cable	EMC104-SM-SM-5000	150322	Jan. 29, 2018	Jan. 28, 2019
Spectrum Analyzer Keysight	N9030A	MY54490679	July 23, 2018	July 22, 2019
Pre-Amplifier EMCI	EMC184045SE	980386	Jan. 29, 2018	Jan. 28, 2019
Horn_Antenna SCHWARZBECK	BBHA 9170	BBHA9170608	Dec. 14, 2017	Dec. 13, 2018
RF Cable	EMC102-KM-KM-1200	160924	Jan. 29, 2018	Jan. 28, 2019
Software	ADT_Radiated_V8.7.08	NA	NA	NA
Antenna Tower & Turn Table Max-Full	MF-7802	MF780208406	NA	NA
Boresight Antenna Fixture	FBA-01	FBA-SIP01	NA	NA

Note:

1. The calibration interval of the above test instruments is 12 months and the calibrations are traceable to NML/ROC and NIST/USA.
2. The test was performed in 966 Chamber No. 3.
3. Tested Date: Nov. 19 to 26, 2018

For other test:

DESCRIPTION & MANUFACTURER	MODEL NO.	SERIAL NO.	CALIBRATED DATE	CALIBRATED UNTIL
Test Receiver Agilent	N9038A	MY50010156	July 12, 2018	July 11, 2019
Pre-Amplifier EMCI	EMC001340	980142	Feb. 09, 2018	Feb. 08, 2019
Loop Antenna(*) Electro-Metrics	EM-6879	264	Dec. 16, 2016	Dec. 15, 2018
RF Cable	NA	LOOPCAB-001	Jan. 15, 2018	Jan. 14, 2019
RF Cable	NA	LOOPCAB-002	Jan. 15, 2018	Jan. 14, 2019
Pre-Amplifier Mini-Circuits	ZFL-1000VH2B	AMP-ZFL-05	May 05, 2018	May 04, 2019
Trilog Broadband Antenna SCHWARZBECK	VULB 9168	9168-361	Nov. 22, 2018	Nov. 21, 2019
RF Cable	8D	966-3-1	Mar. 20, 2018	Mar. 19, 2019
RF Cable	8D	966-3-2	Mar. 20, 2018	Mar. 19, 2019
RF Cable	8D	966-3-3	Mar. 20, 2018	Mar. 19, 2019
Fixed attenuator Mini-Circuits	UNAT-5+	PAD-3m-3-01	Sep. 27, 2018	Sep. 26, 2019
Software	ADT_Radiated_V8.7.08	NA	NA	NA
Antenna Tower & Turn Table Max-Full	MF-7802	MF780208406	NA	NA
Spectrum Analyzer R&S	FSV40	100964	June 20, 2018	June 19, 2019
Power meter Anritsu	ML2495A	1014008	May 09, 2018	May 08, 2019
Power sensor Anritsu	MA2411B	0917122	May 09, 2018	May 08, 2019
AC Power Source Extech Electronics	6205	1440452	NA	NA
Temperature & Humidity Chamber Giant Force	GTH-150-40-SP-AR	MAA0812-008	Jan. 10, 2018	Jan. 09, 2019
True RMS Clamp Meter FLUKE	325	31130711WS	May 22, 2018	May 21, 2019

Note:

1. The calibration interval of the above test instruments is 12 months and the calibrations are traceable to NML/ROC and NIST/USA.
2. *The calibration interval of the above test instruments is 24 months and the calibrations are traceable to NML/ROC and NIST/USA.
3. The test was performed in 966 Chamber No. 3.
4. Loop antenna was used for all emissions below 30 MHz.
5. Tested Date: Dec. 07 to 10, 2018

4.1.3 Test Procedure

For Radiated emission below 30MHz

- a. The EUT was placed on the top of a rotating table 0.8 meters above the ground at a 3 meter chamber room. The table was rotated 360 degrees to determine the position of the highest radiation.
- b. The EUT was set 3 meters away from the interference-receiving antenna, which was mounted on the top of a variable-height antenna tower.
- c. Parallel, perpendicular, and ground-parallel orientations of the antenna are set to make the measurement.
- d. For each suspected emission, the EUT was arranged to its worst case and the rotatable table was turned from 0 degrees to 360 degrees to find the maximum reading.
- e. The test-receiver system was set to Quasi-Peak Detect Function and Specified Bandwidth with Maximum Hold Mode.

NOTE:

1. The resolution bandwidth and video bandwidth of test receiver/spectrum analyzer is 9kHz at frequency below 30MHz.

For Radiated emission above 30MHz

- a. The EUT was placed on the top of a rotating table 0.8 meters (for 30MHz ~ 1GHz) / 1.5 meters (for above 1GHz) above the ground at 3 meter chamber room for test. The table was rotated 360 degrees to determine the position of the highest radiation.
- b. The EUT was set 3 meters away from the interference-receiving antenna, which was mounted on the top of a variable-height antenna tower.
- c. The height of antenna is varied from one meter to four meters above the ground to determine the maximum value of the field strength. Both horizontal and vertical polarizations of the antenna are set to make the measurement.
- d. For each suspected emission, the EUT was arranged to its worst case and then the antenna was tuned to heights from 1 meter to 4 meters and the rotatable table was turned from 0 degrees to 360 degrees to find the maximum reading.
- e. The test-receiver system was set to quasi-peak detect function and specified bandwidth with maximum hold mode when the test frequency is below 1 GHz.
- f. The test-receiver system was set to peak and average detects function and specified bandwidth with maximum hold mode when the test frequency is above 1 GHz. If the peak reading value also meets average limit, measurement with the average detector is unnecessary.

Note:

1. The resolution bandwidth and video bandwidth of test receiver/spectrum analyzer is 120kHz for Quasi-peak detection (QP) at frequency below 1GHz.
2. The resolution bandwidth of test receiver/spectrum analyzer is 1 MHz and the video bandwidth is 3 MHz for Peak detection (PK) at frequency above 1GHz.
3. The resolution bandwidth of test receiver/spectrum analyzer is 1MHz and the video bandwidth is $\geq 1/T$ (Duty cycle < 98%) or 10Hz (Duty cycle $\geq 98\%$) for Average detection (AV) at frequency above 1GHz.
4. All modes of operation were investigated and the worst-case emissions are reported.

4.1.4 Deviation from Test Standard

No deviation.

4.1.5 Test Setup

For Radiated emission below 30MHz

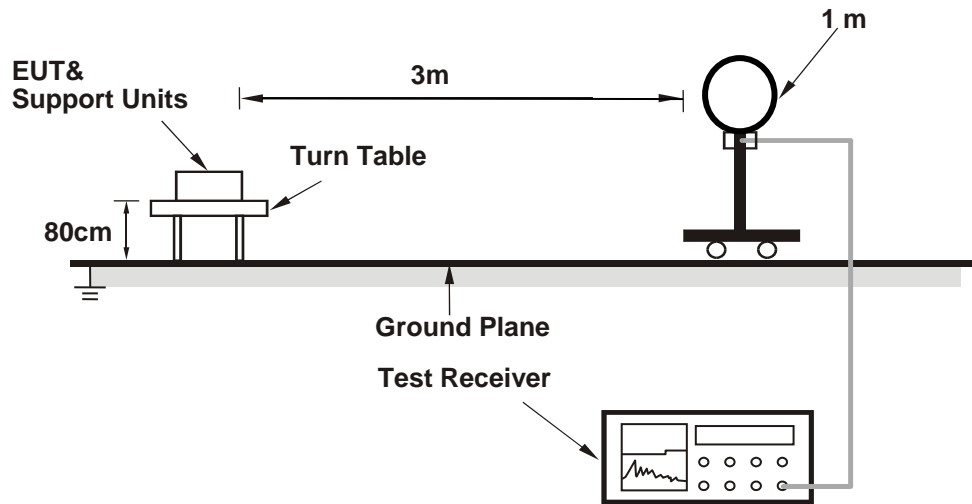

For Radiated emission 30MHz to 1GHz

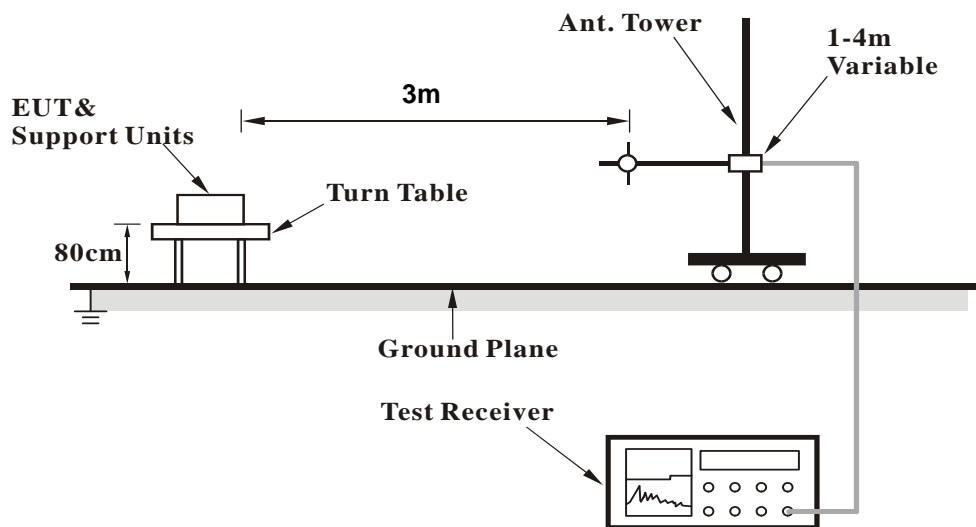

For Radiated emission above 1GHz

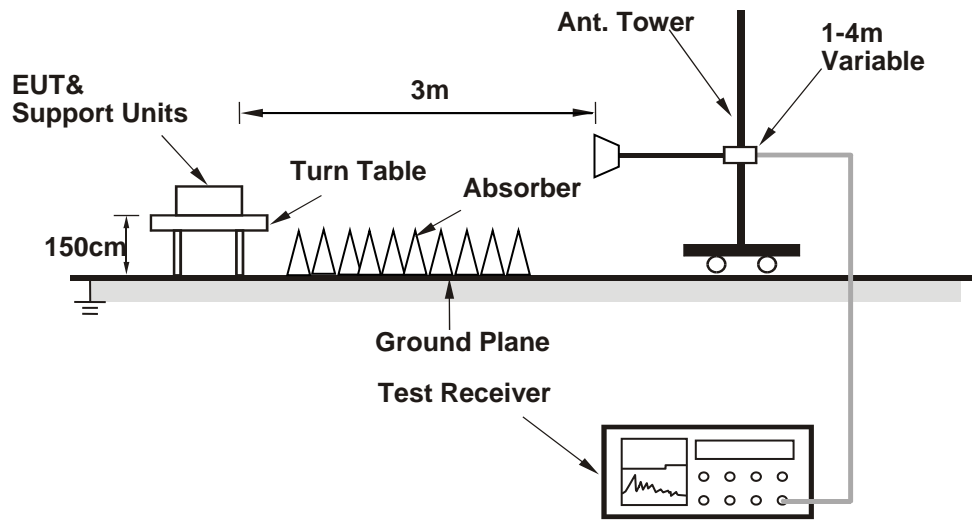

For the actual test configuration, please refer to the attached file (Test Setup Photo).

4.1.6 EUT Operating Condition

- a. Connected the EUT with the Notebook Computer which is placed on remote site.
- b. Controlling software (QSPR (5.0-00148)) has been activated to set the EUT on specific status.

4.1.7 Test Results

Above 1GHz Data:

802.11a

CHANNEL	TX Channel 36	DETECTOR FUNCTION	Peak (PK)
FREQUENCY RANGE	1GHz ~ 40GHz		Average (AV)

ANTENNA POLARITY & TEST DISTANCE: HORIZONTAL AT 3 M

NO.	FREQ. (MHz)	EMISSION LEVEL (dBuV/m)	LIMIT (dBuV/m)	MARGIN (dB)	ANTENNA HEIGHT (m)	TABLE ANGLE (Degree)	RAW VALUE (dBuV)	CORRECTION FACTOR (dB/m)
1	5150.00	58.8 PK	74.0	-15.2	2.61 H	316	56.2	2.6
2	5150.00	45.8 AV	54.0	-8.2	2.61 H	316	43.2	2.6
3	*5180.00	119.1 PK			2.61 H	316	116.6	2.5
4	*5180.00	107.1 AV			2.61 H	316	104.6	2.5
5	#10360.00	43.9 PK	68.2	-24.3	1.94 H	360	32.0	11.9
6	15540.00	42.2 PK	74.0	-31.8	2.76 H	134	29.8	12.4
7	15540.00	31.5 AV	54.0	-22.5	2.76 H	134	19.1	12.4

ANTENNA POLARITY & TEST DISTANCE: VERTICAL AT 3 M

NO.	FREQ. (MHz)	EMISSION LEVEL (dBuV/m)	LIMIT (dBuV/m)	MARGIN (dB)	ANTENNA HEIGHT (m)	TABLE ANGLE (Degree)	RAW VALUE (dBuV)	CORRECTION FACTOR (dB/m)
1	5150.00	58.6 PK	74.0	-15.4	1.85 V	352	56.0	2.6
2	5150.00	44.6 AV	54.0	-9.4	1.85 V	352	42.0	2.6
3	*5180.00	117.5 PK			1.85 V	352	115.0	2.5
4	*5180.00	105.8 AV			1.85 V	352	103.3	2.5
5	#10360.00	46.0 PK	68.2	-22.2	1.67 V	216	34.1	11.9
6	15540.00	47.5 PK	74.0	-26.5	2.01 V	246	35.1	12.4
7	15540.00	36.4 AV	54.0	-17.6	2.01 V	246	24.0	12.4

REMARKS:

1. Emission Level(dBuV/m) = Raw Value(dBuV) + Correction Factor(dB/m)
2. Correction Factor(dB/m) = Antenna Factor(dB/m) + Cable Factor(dB) – Pre-Amplifier Factor(dB)
3. The other emission levels were very low against the limit.
4. Margin value = Emission Level – Limit value
5. " * ": Fundamental frequency.
6. " # ": The radiated frequency is out of the restricted band.

CHANNEL	TX Channel 40	DETECTOR FUNCTION	Peak (PK)
FREQUENCY RANGE	1GHz ~ 40GHz		Average (AV)

ANTENNA POLARITY & TEST DISTANCE: HORIZONTAL AT 3 M								
NO.	FREQ. (MHz)	EMISSION LEVEL (dBuV/m)	LIMIT (dBuV/m)	MARGIN (dB)	ANTENNA HEIGHT (m)	TABLE ANGLE (Degree)	RAW VALUE (dBuV)	CORRECTION FACTOR (dB/m)
1	*5200.00	119.3 PK			2.72 H	326	116.9	2.4
2	*5200.00	107.4 AV			2.72 H	326	105.0	2.4
3	#10400.00	44.3 PK	68.2	-23.9	1.65 H	338	32.1	12.2
4	15600.00	52.6 PK	74.0	-21.4	1.72 H	234	39.7	12.9
5	15600.00	39.8 AV	54.0	-14.2	1.72 H	234	26.9	12.9

ANTENNA POLARITY & TEST DISTANCE: VERTICAL AT 3 M								
NO.	FREQ. (MHz)	EMISSION LEVEL (dBuV/m)	LIMIT (dBuV/m)	MARGIN (dB)	ANTENNA HEIGHT (m)	TABLE ANGLE (Degree)	RAW VALUE (dBuV)	CORRECTION FACTOR (dB/m)
1	*5200.00	117.7 PK			1.84 V	336	115.3	2.4
2	*5200.00	106.1 AV			1.84 V	336	103.7	2.4
3	#10400.00	46.4 PK	68.2	-21.8	1.64 V	212	34.2	12.2
4	15600.00	48.0 PK	74.0	-26.0	1.96 V	248	35.1	12.9
5	15600.00	36.7 AV	54.0	-17.3	1.96 V	248	23.8	12.9

REMARKS:

1. Emission Level(dBuV/m) = Raw Value(dBuV) + Correction Factor(dB/m)
2. Correction Factor(dB/m) = Antenna Factor(dB/m) + Cable Factor(dB) – Pre-Amplifier Factor(dB)
3. The other emission levels were very low against the limit.
4. Margin value = Emission Level – Limit value
5. " * ": Fundamental frequency.
6. " # ": The radiated frequency is out of the restricted band.

CHANNEL	TX Channel 48	DETECTOR FUNCTION	Peak (PK)
FREQUENCY RANGE	1GHz ~ 40GHz		Average (AV)

ANTENNA POLARITY & TEST DISTANCE: HORIZONTAL AT 3 M								
NO.	FREQ. (MHz)	EMISSION LEVEL (dBuV/m)	LIMIT (dBuV/m)	MARGIN (dB)	ANTENNA HEIGHT (m)	TABLE ANGLE (Degree)	RAW VALUE (dBuV)	CORRECTION FACTOR (dB/m)
1	*5240.00	118.8 PK			2.66 H	316	116.6	2.2
2	*5240.00	106.9 AV			2.66 H	316	104.7	2.2
3	5350.00	55.4 PK	74.0	-18.6	2.66 H	316	53.1	2.3
4	5350.00	44.7 AV	54.0	-9.3	2.66 H	316	42.4	2.3
5	#10480.00	44.7 PK	68.2	-23.5	1.64 H	356	32.3	12.4
6	15720.00	53.0 PK	74.0	-21.0	1.68 H	245	41.0	12.0
7	15720.00	40.3 AV	54.0	-13.7	1.68 H	245	28.3	12.0

ANTENNA POLARITY & TEST DISTANCE: VERTICAL AT 3 M								
NO.	FREQ. (MHz)	EMISSION LEVEL (dBuV/m)	LIMIT (dBuV/m)	MARGIN (dB)	ANTENNA HEIGHT (m)	TABLE ANGLE (Degree)	RAW VALUE (dBuV)	CORRECTION FACTOR (dB/m)
1	*5240.00	117.2 PK			1.86 V	360	115.0	2.2
2	*5240.00	105.6 AV			1.86 V	360	103.4	2.2
3	5350.00	47.6 PK	74.0	-26.4	1.86 V	360	45.3	2.3
4	5350.00	38.1 AV	54.0	-15.9	1.86 V	360	35.8	2.3
5	#10480.00	45.9 PK	68.2	-22.3	1.62 V	219	33.5	12.4
6	15720.00	47.3 PK	74.0	-26.7	1.98 V	241	35.3	12.0
7	15720.00	36.3 AV	54.0	-17.7	1.98 V	241	24.3	12.0

REMARKS:

1. Emission Level(dBuV/m) = Raw Value(dBuV) + Correction Factor(dB/m)
2. Correction Factor(dB/m) = Antenna Factor(dB/m) + Cable Factor(dB) – Pre-Amplifier Factor(dB)
3. The other emission levels were very low against the limit.
4. Margin value = Emission Level – Limit value
5. " * ": Fundamental frequency.
6. " # ": The radiated frequency is out of the restricted band.

CHANNEL	TX Channel 149	DETECTOR FUNCTION	Peak (PK)
FREQUENCY RANGE	1GHz ~ 40GHz		Average (AV)

ANTENNA POLARITY & TEST DISTANCE: HORIZONTAL AT 3 M								
NO.	FREQ. (MHz)	EMISSION LEVEL (dBuV/m)	LIMIT (dBuV/m)	MARGIN (dB)	ANTENNA HEIGHT (m)	TABLE ANGLE (Degree)	RAW VALUE (dBuV)	CORRECTION FACTOR (dB/m)
1	#5559.37	54.6 PK	68.2	-13.6	2.08 H	159	51.8	2.8
2	*5745.00	115.4 PK			2.08 H	159	112.5	2.9
3	*5745.00	106.0 AV			2.08 H	159	103.1	2.9
4	#6005.13	53.4 PK	68.2	-14.8	2.08 H	159	50.2	3.2
5	11490.00	44.4 PK	74.0	-29.6	1.59 H	338	32.1	12.3
6	11490.00	40.3 AV	54.0	-13.7	1.59 H	338	28.0	12.3
7	#17235.00	52.8 PK	68.2	-15.4	1.74 H	237	37.5	15.3

ANTENNA POLARITY & TEST DISTANCE: VERTICAL AT 3 M								
NO.	FREQ. (MHz)	EMISSION LEVEL (dBuV/m)	LIMIT (dBuV/m)	MARGIN (dB)	ANTENNA HEIGHT (m)	TABLE ANGLE (Degree)	RAW VALUE (dBuV)	CORRECTION FACTOR (dB/m)
1	#5641.72	56.7 PK	68.2	-11.5	1.61 V	127	54.0	2.7
2	*5745.00	116.0 PK			1.61 V	127	113.1	2.9
3	*5745.00	107.1 AV			1.61 V	127	104.2	2.9
4	#5938.45	54.5 PK	68.2	-13.7	1.61 V	127	51.1	3.4
5	11490.00	47.3 PK	74.0	-26.7	3.15 V	298	35.0	12.3
6	11490.00	37.7 AV	54.0	-16.3	3.15 V	298	25.4	12.3
7	#17235.00	50.7 PK	68.2	-17.5	2.67 V	255	35.4	15.3

REMARKS:

1. Emission Level(dBuV/m) = Raw Value(dBuV) + Correction Factor(dB/m)
2. Correction Factor(dB/m) = Antenna Factor(dB/m) + Cable Factor(dB) – Pre-Amplifier Factor(dB)
3. The other emission levels were very low against the limit.
4. Margin value = Emission Level – Limit value
5. " * ": Fundamental frequency.
6. " # ": The radiated frequency is out of the restricted band.

CHANNEL	TX Channel 157	DETECTOR FUNCTION	Peak (PK)
FREQUENCY RANGE	1GHz ~ 40GHz		Average (AV)

ANTENNA POLARITY & TEST DISTANCE: HORIZONTAL AT 3 M								
NO.	FREQ. (MHz)	EMISSION LEVEL (dBuV/m)	LIMIT (dBuV/m)	MARGIN (dB)	ANTENNA HEIGHT (m)	TABLE ANGLE (Degree)	RAW VALUE (dBuV)	CORRECTION FACTOR (dB/m)
1	#5627.23	55.6 PK	68.2	-12.6	1.70 H	313	52.8	2.8
2	*5785.00	115.8 PK			1.70 H	313	112.7	3.1
3	*5785.00	106.2 AV			1.70 H	313	103.1	3.1
4	#5992.11	54.6 PK	68.2	-13.6	1.70 H	313	51.4	3.2
5	11570.00	43.8 PK	74.0	-30.2	1.64 H	356	31.4	12.4
6	11570.00	39.4 AV	54.0	-14.6	1.64 H	356	27.0	12.4
7	#17355.00	53.7 PK	68.2	-14.5	1.82 H	243	37.7	16.0

ANTENNA POLARITY & TEST DISTANCE: VERTICAL AT 3 M								
NO.	FREQ. (MHz)	EMISSION LEVEL (dBuV/m)	LIMIT (dBuV/m)	MARGIN (dB)	ANTENNA HEIGHT (m)	TABLE ANGLE (Degree)	RAW VALUE (dBuV)	CORRECTION FACTOR (dB/m)
1	#5594.46	55.7 PK	68.2	-12.5	1.85 V	130	52.9	2.8
2	*5785.00	116.3 PK			1.85 V	130	113.2	3.1
3	*5785.00	107.4 AV			1.85 V	130	104.3	3.1
4	#5931.23	55.2 PK	68.2	-13.0	1.85 V	130	51.8	3.4
5	11570.00	47.0 PK	74.0	-27.0	3.20 V	297	34.6	12.4
6	11570.00	37.7 AV	54.0	-16.3	3.20 V	297	25.3	12.4
7	#17355.00	50.8 PK	68.2	-17.4	2.72 V	261	34.8	16.0

REMARKS:

1. Emission Level(dBuV/m) = Raw Value(dBuV) + Correction Factor(dB/m)
2. Correction Factor(dB/m) = Antenna Factor(dB/m) + Cable Factor(dB) – Pre-Amplifier Factor(dB)
3. The other emission levels were very low against the limit.
4. Margin value = Emission Level – Limit value
5. " * ": Fundamental frequency.
6. " # ": The radiated frequency is out of the restricted band.

CHANNEL	TX Channel 165	DETECTOR FUNCTION	Peak (PK)
FREQUENCY RANGE	1GHz ~ 40GHz		Average (AV)

ANTENNA POLARITY & TEST DISTANCE: HORIZONTAL AT 3 M								
NO.	FREQ. (MHz)	EMISSION LEVEL (dBuV/m)	LIMIT (dBuV/m)	MARGIN (dB)	ANTENNA HEIGHT (m)	TABLE ANGLE (Degree)	RAW VALUE (dBuV)	CORRECTION FACTOR (dB/m)
1	#5639.41	55.1 PK	68.2	-13.1	1.50 H	333	52.4	2.7
2	*5825.00	115.6 PK			1.50 H	333	112.4	3.2
3	*5825.00	106.3 AV			1.50 H	333	103.1	3.2
4	#5950.91	53.7 PK	68.2	-14.5	1.50 H	333	50.5	3.2
5	11650.00	44.1 PK	74.0	-29.9	1.63 H	338	31.7	12.4
6	11650.00	39.7 AV	54.0	-14.3	1.63 H	338	27.3	12.4
7	#17475.00	52.7 PK	68.2	-15.5	1.81 H	249	35.3	17.4

ANTENNA POLARITY & TEST DISTANCE: VERTICAL AT 3 M								
NO.	FREQ. (MHz)	EMISSION LEVEL (dBuV/m)	LIMIT (dBuV/m)	MARGIN (dB)	ANTENNA HEIGHT (m)	TABLE ANGLE (Degree)	RAW VALUE (dBuV)	CORRECTION FACTOR (dB/m)
1	#5626.61	55.1 PK	68.2	-13.1	1.70 V	286	52.3	2.8
2	*5825.00	116.4 PK			1.70 V	286	113.2	3.2
3	*5825.00	107.5 AV			1.70 V	286	104.3	3.2
4	#6009.76	54.4 PK	68.2	-13.8	1.70 V	286	51.2	3.2
5	11650.00	46.3 PK	74.0	-27.7	3.17 V	309	33.9	12.4
6	11650.00	37.0 AV	54.0	-17.0	3.17 V	309	24.6	12.4
7	#17475.00	50.9 PK	68.2	-17.3	2.72 V	280	33.5	17.4

REMARKS:

1. Emission Level(dBuV/m) = Raw Value(dBuV) + Correction Factor(dB/m)
2. Correction Factor(dB/m) = Antenna Factor(dB/m) + Cable Factor(dB) – Pre-Amplifier Factor(dB)
3. The other emission levels were very low against the limit.
4. Margin value = Emission Level – Limit value
5. " * ": Fundamental frequency.
6. " # ": The radiated frequency is out of the restricted band.

802.11ax (HE20)

CHANNEL	TX Channel 36	DETECTOR FUNCTION	Peak (PK)
FREQUENCY RANGE	1GHz ~ 40GHz		Average (AV)

ANTENNA POLARITY & TEST DISTANCE: HORIZONTAL AT 3 M								
NO.	FREQ. (MHz)	EMISSION LEVEL (dBuV/m)	LIMIT (dBuV/m)	MARGIN (dB)	ANTENNA HEIGHT (m)	TABLE ANGLE (Degree)	RAW VALUE (dBuV)	CORRECTION FACTOR (dB/m)
1	5150.00	58.5 PK	74.0	-15.5	2.02 H	160	55.9	2.6
2	5150.00	45.6 AV	54.0	-8.4	2.02 H	160	43.0	2.6
3	*5180.00	118.9 PK			2.02 H	160	116.4	2.5
4	*5180.00	107.1 AV			2.02 H	160	104.6	2.5
5	#10360.00	43.8 PK	68.2	-24.4	1.63 H	355	31.9	11.9
6	15540.00	52.4 PK	74.0	-21.6	1.74 H	248	40.0	12.4
7	15540.00	39.4 AV	54.0	-14.6	1.74 H	248	27.0	12.4

ANTENNA POLARITY & TEST DISTANCE: VERTICAL AT 3 M								
NO.	FREQ. (MHz)	EMISSION LEVEL (dBuV/m)	LIMIT (dBuV/m)	MARGIN (dB)	ANTENNA HEIGHT (m)	TABLE ANGLE (Degree)	RAW VALUE (dBuV)	CORRECTION FACTOR (dB/m)
1	5150.00	58.1 PK	74.0	-15.9	1.91 V	355	55.5	2.6
2	5150.00	44.2 AV	54.0	-9.8	1.91 V	355	41.6	2.6
3	*5180.00	117.3 PK			1.91 V	355	114.8	2.5
4	*5180.00	105.8 AV			1.91 V	355	103.3	2.5
5	#10360.00	46.0 PK	68.2	-22.2	1.69 V	228	34.1	11.9
6	15540.00	47.8 PK	74.0	-26.2	1.99 V	245	35.4	12.4
7	15540.00	36.4 AV	54.0	-17.6	1.99 V	245	24.0	12.4

REMARKS:

1. Emission Level(dBuV/m) = Raw Value(dBuV) + Correction Factor(dB/m)
2. Correction Factor(dB/m) = Antenna Factor(dB/m) + Cable Factor(dB) – Pre-Amplifier Factor(dB)
3. The other emission levels were very low against the limit.
4. Margin value = Emission Level – Limit value
5. " * ": Fundamental frequency.
6. " # ": The radiated frequency is out of the restricted band.

CHANNEL	TX Channel 40	DETECTOR FUNCTION	Peak (PK)
FREQUENCY RANGE	1GHz ~ 40GHz		Average (AV)

ANTENNA POLARITY & TEST DISTANCE: HORIZONTAL AT 3 M								
NO.	FREQ. (MHz)	EMISSION LEVEL (dBuV/m)	LIMIT (dBuV/m)	MARGIN (dB)	ANTENNA HEIGHT (m)	TABLE ANGLE (Degree)	RAW VALUE (dBuV)	CORRECTION FACTOR (dB/m)
1	*5200.00	118.5 PK			2.03 H	175	116.1	2.4
2	*5200.00	106.6 AV			2.03 H	175	104.2	2.4
3	#10400.00	44.5 PK	68.2	-23.7	1.68 H	360	32.3	12.2
4	15600.00	53.5 PK	74.0	-20.5	1.81 H	238	40.6	12.9
5	15600.00	40.4 AV	54.0	-13.6	1.81 H	238	27.5	12.9

ANTENNA POLARITY & TEST DISTANCE: VERTICAL AT 3 M								
NO.	FREQ. (MHz)	EMISSION LEVEL (dBuV/m)	LIMIT (dBuV/m)	MARGIN (dB)	ANTENNA HEIGHT (m)	TABLE ANGLE (Degree)	RAW VALUE (dBuV)	CORRECTION FACTOR (dB/m)
1	*5200.00	116.9 PK			1.94 V	360	114.5	2.4
2	*5200.00	105.3 AV			1.94 V	360	102.9	2.4
3	#10400.00	45.8 PK	68.2	-22.4	1.70 V	208	33.6	12.2
4	15600.00	47.7 PK	74.0	-26.3	2.01 V	257	34.8	12.9
5	15600.00	36.7 AV	54.0	-17.3	2.01 V	257	23.8	12.9

REMARKS:

1. Emission Level(dBuV/m) = Raw Value(dBuV) + Correction Factor(dB/m)
2. Correction Factor(dB/m) = Antenna Factor(dB/m) + Cable Factor(dB) – Pre-Amplifier Factor(dB)
3. The other emission levels were very low against the limit.
4. Margin value = Emission Level – Limit value
5. " * ": Fundamental frequency.
6. " # ": The radiated frequency is out of the restricted band.

CHANNEL	TX Channel 48	DETECTOR FUNCTION	Peak (PK)
FREQUENCY RANGE	1GHz ~ 40GHz		Average (AV)

ANTENNA POLARITY & TEST DISTANCE: HORIZONTAL AT 3 M								
NO.	FREQ. (MHz)	EMISSION LEVEL (dBuV/m)	LIMIT (dBuV/m)	MARGIN (dB)	ANTENNA HEIGHT (m)	TABLE ANGLE (Degree)	RAW VALUE (dBuV)	CORRECTION FACTOR (dB/m)
1	*5240.00	112.6 PK			2.07 H	176	110.4	2.2
2	*5240.00	100.5 AV			2.07 H	176	98.3	2.2
3	5350.00	55.7 PK	74.0	-18.3	2.07 H	176	53.4	2.3
4	5350.00	44.8 AV	54.0	-9.2	2.07 H	176	42.5	2.3
5	#10480.00	44.4 PK	68.2	-23.8	1.66 H	353	32.0	12.4
6	15720.00	53.3 PK	74.0	-20.7	1.77 H	219	41.3	12.0
7	15720.00	40.7 AV	54.0	-13.3	1.77 H	219	28.7	12.0

ANTENNA POLARITY & TEST DISTANCE: VERTICAL AT 3 M								
NO.	FREQ. (MHz)	EMISSION LEVEL (dBuV/m)	LIMIT (dBuV/m)	MARGIN (dB)	ANTENNA HEIGHT (m)	TABLE ANGLE (Degree)	RAW VALUE (dBuV)	CORRECTION FACTOR (dB/m)
1	*5240.00	111.0 PK			1.93 V	337	108.8	2.2
2	*5240.00	99.2 AV			1.93 V	337	97.0	2.2
3	5350.00	47.0 PK	74.0	-27.0	1.93 V	337	44.7	2.3
4	5350.00	37.6 AV	54.0	-16.4	1.93 V	337	35.3	2.3
5	#10480.00	46.2 PK	68.2	-22.0	1.62 V	223	33.8	12.4
6	15720.00	47.6 PK	74.0	-26.4	1.98 V	238	35.6	12.0
7	15720.00	36.7 AV	54.0	-17.3	1.98 V	238	24.7	12.0

REMARKS:

1. Emission Level(dBuV/m) = Raw Value(dBuV) + Correction Factor(dB/m)
2. Correction Factor(dB/m) = Antenna Factor(dB/m) + Cable Factor(dB) – Pre-Amplifier Factor(dB)
3. The other emission levels were very low against the limit.
4. Margin value = Emission Level – Limit value
5. " * ": Fundamental frequency.
6. " # ": The radiated frequency is out of the restricted band.

CHANNEL	TX Channel 149	DETECTOR FUNCTION	Peak (PK)
FREQUENCY RANGE	1GHz ~ 40GHz		Average (AV)

ANTENNA POLARITY & TEST DISTANCE: HORIZONTAL AT 3 M								
NO.	FREQ. (MHz)	EMISSION LEVEL (dBuV/m)	LIMIT (dBuV/m)	MARGIN (dB)	ANTENNA HEIGHT (m)	TABLE ANGLE (Degree)	RAW VALUE (dBuV)	CORRECTION FACTOR (dB/m)
1	#5651.66	56.6 PK	69.4	-12.8	2.10 H	167	53.8	2.8
2	*5745.00	117.4 PK			2.10 H	167	114.5	2.9
3	*5745.00	105.2 AV			2.10 H	167	102.3	2.9
4	#5952.86	54.4 PK	68.2	-13.8	2.10 H	167	51.2	3.2
5	11490.00	43.8 PK	74.0	-30.2	1.63 H	339	31.5	12.3
6	11490.00	39.5 AV	54.0	-14.5	1.63 H	339	27.2	12.3
7	#17235.00	52.4 PK	68.2	-15.8	1.73 H	236	37.1	15.3

ANTENNA POLARITY & TEST DISTANCE: VERTICAL AT 3 M								
NO.	FREQ. (MHz)	EMISSION LEVEL (dBuV/m)	LIMIT (dBuV/m)	MARGIN (dB)	ANTENNA HEIGHT (m)	TABLE ANGLE (Degree)	RAW VALUE (dBuV)	CORRECTION FACTOR (dB/m)
1	#5646.79	58.1 PK	68.2	-10.1	1.66 V	119	55.4	2.7
2	*5745.00	118.8 PK			1.66 V	119	115.9	2.9
3	*5745.00	106.1 AV			1.66 V	119	103.2	2.9
4	#5930.78	56.0 PK	68.2	-12.2	1.66 V	119	52.6	3.4
5	11490.00	46.0 PK	74.0	-28.0	1.68 V	226	33.7	12.3
6	11490.00	35.6 AV	54.0	-18.4	1.68 V	226	23.3	12.3
7	#17235.00	47.2 PK	68.2	-21.0	2.02 V	261	31.9	15.3

REMARKS:

1. Emission Level(dBuV/m) = Raw Value(dBuV) + Correction Factor(dB/m)
2. Correction Factor(dB/m) = Antenna Factor(dB/m) + Cable Factor(dB) – Pre-Amplifier Factor(dB)
3. The other emission levels were very low against the limit.
4. Margin value = Emission Level – Limit value
5. " * ": Fundamental frequency.
6. " # ": The radiated frequency is out of the restricted band.

CHANNEL	TX Channel 157	DETECTOR FUNCTION	Peak (PK)
FREQUENCY RANGE	1GHz ~ 40GHz		Average (AV)

ANTENNA POLARITY & TEST DISTANCE: HORIZONTAL AT 3 M								
NO.	FREQ. (MHz)	EMISSION LEVEL (dBuV/m)	LIMIT (dBuV/m)	MARGIN (dB)	ANTENNA HEIGHT (m)	TABLE ANGLE (Degree)	RAW VALUE (dBuV)	CORRECTION FACTOR (dB/m)
1	#5625.55	53.7 PK	68.2	-14.5	2.39 H	229	50.9	2.8
2	*5785.00	117.8 PK			2.39 H	229	114.7	3.1
3	*5785.00	105.8 AV			2.39 H	229	102.7	3.1
4	#5924.03	53.3 PK	68.9	-15.6	2.39 H	229	49.9	3.4
5	11570.00	44.7 PK	74.0	-29.3	1.59 H	360	32.3	12.4
6	11570.00	40.1 AV	54.0	-13.9	1.59 H	360	27.7	12.4
7	#17355.00	53.3 PK	68.2	-14.9	1.79 H	248	37.3	16.0

ANTENNA POLARITY & TEST DISTANCE: VERTICAL AT 3 M								
NO.	FREQ. (MHz)	EMISSION LEVEL (dBuV/m)	LIMIT (dBuV/m)	MARGIN (dB)	ANTENNA HEIGHT (m)	TABLE ANGLE (Degree)	RAW VALUE (dBuV)	CORRECTION FACTOR (dB/m)
1	#5589.01	58.1 PK	68.2	-10.1	1.69 V	283	55.3	2.8
2	*5785.00	118.6 PK			1.69 V	283	115.5	3.1
3	*5785.00	106.9 AV			1.69 V	283	103.8	3.1
4	#5938.61	56.7 PK	68.2	-11.5	1.69 V	283	53.3	3.4
5	11570.00	45.8 PK	74.0	-28.2	1.65 V	229	33.4	12.4
6	11570.00	35.6 AV	54.0	-18.4	1.65 V	229	23.2	12.4
7	#17355.00	47.7 PK	68.2	-20.5	2.02 V	258	31.7	16.0

REMARKS:

1. Emission Level(dBuV/m) = Raw Value(dBuV) + Correction Factor(dB/m)
2. Correction Factor(dB/m) = Antenna Factor(dB/m) + Cable Factor(dB) – Pre-Amplifier Factor(dB)
3. The other emission levels were very low against the limit.
4. Margin value = Emission Level – Limit value
5. " * ": Fundamental frequency.
6. " # ": The radiated frequency is out of the restricted band.

CHANNEL	TX Channel 165	DETECTOR FUNCTION	Peak (PK)
FREQUENCY RANGE	1GHz ~ 40GHz		Average (AV)

ANTENNA POLARITY & TEST DISTANCE: HORIZONTAL AT 3 M								
NO.	FREQ. (MHz)	EMISSION LEVEL (dBuV/m)	LIMIT (dBuV/m)	MARGIN (dB)	ANTENNA HEIGHT (m)	TABLE ANGLE (Degree)	RAW VALUE (dBuV)	CORRECTION FACTOR (dB/m)
1	#5636.37	54.4 PK	68.2	-13.8	1.70 H	298	51.7	2.7
2	*5825.00	117.4 PK			1.70 H	298	114.2	3.2
3	*5825.00	105.4 AV			1.70 H	298	102.2	3.2
4	#6020.27	54.3 PK	68.2	-13.9	1.70 H	298	51.1	3.2
5	11650.00	44.1 PK	74.0	-29.9	1.65 H	360	31.7	12.4
6	11650.00	39.7 AV	54.0	-14.3	1.65 H	360	27.3	12.4
7	#17475.00	53.4 PK	68.2	-14.8	1.82 H	245	36.0	17.4

ANTENNA POLARITY & TEST DISTANCE: VERTICAL AT 3 M								
NO.	FREQ. (MHz)	EMISSION LEVEL (dBuV/m)	LIMIT (dBuV/m)	MARGIN (dB)	ANTENNA HEIGHT (m)	TABLE ANGLE (Degree)	RAW VALUE (dBuV)	CORRECTION FACTOR (dB/m)
1	#5632.63	58.3 PK	68.2	-9.9	1.68 V	202	55.5	2.8
2	*5825.00	118.4 PK			1.68 V	202	115.2	3.2
3	*5825.00	106.5 AV			1.68 V	202	103.3	3.2
4	#5927.90	56.7 PK	68.2	-11.5	1.68 V	202	53.3	3.4
5	11650.00	46.0 PK	74.0	-28.0	1.64 V	224	33.6	12.4
6	11650.00	35.7 AV	54.0	-18.3	1.64 V	224	23.3	12.4
7	#17475.00	47.2 PK	68.2	-21.0	2.04 V	230	29.8	17.4

REMARKS:

1. Emission Level(dBuV/m) = Raw Value(dBuV) + Correction Factor(dB/m)
2. Correction Factor(dB/m) = Antenna Factor(dB/m) + Cable Factor(dB) – Pre-Amplifier Factor(dB)
3. The other emission levels were very low against the limit.
4. Margin value = Emission Level – Limit value
5. " * ": Fundamental frequency.
6. " # ": The radiated frequency is out of the restricted band.

802.11ax (HE40)

CHANNEL	TX Channel 38	DETECTOR FUNCTION	Peak (PK)
FREQUENCY RANGE	1GHz ~ 40GHz		Average (AV)

ANTENNA POLARITY & TEST DISTANCE: HORIZONTAL AT 3 M								
NO.	FREQ. (MHz)	EMISSION LEVEL (dBuV/m)	LIMIT (dBuV/m)	MARGIN (dB)	ANTENNA HEIGHT (m)	TABLE ANGLE (Degree)	RAW VALUE (dBuV)	CORRECTION FACTOR (dB/m)
1	5150.00	59.4 PK	74.0	-14.6	2.06 H	167	56.8	2.6
2	5150.00	46.3 AV	54.0	-7.7	2.06 H	167	43.7	2.6
3	*5190.00	115.9 PK			2.06 H	167	113.4	2.5
4	*5190.00	104.1 AV			2.06 H	167	101.6	2.5
5	5350.00	55.2 PK	74.0	-18.8	2.06 H	167	52.9	2.3
6	5350.00	44.6 AV	54.0	-9.4	2.06 H	167	42.3	2.3
7	#10380.00	44.3 PK	68.2	-23.9	1.64 H	355	32.3	12.0
8	15570.00	53.1 PK	74.0	-20.9	1.73 H	224	40.5	12.6
9	15570.00	40.2 AV	54.0	-13.8	1.73 H	224	27.6	12.6

ANTENNA POLARITY & TEST DISTANCE: VERTICAL AT 3 M								
NO.	FREQ. (MHz)	EMISSION LEVEL (dBuV/m)	LIMIT (dBuV/m)	MARGIN (dB)	ANTENNA HEIGHT (m)	TABLE ANGLE (Degree)	RAW VALUE (dBuV)	CORRECTION FACTOR (dB/m)
1	5150.00	58.0 PK	74.0	-16.0	1.97 V	347	55.4	2.6
2	5150.00	44.3 AV	54.0	-9.7	1.97 V	347	41.7	2.6
3	*5190.00	114.3 PK			1.97 V	347	111.8	2.5
4	*5190.00	102.8 AV			1.97 V	347	100.3	2.5
5	5350.00	47.1 PK	74.0	-26.9	1.97 V	347	44.8	2.3
6	5350.00	37.7 AV	54.0	-16.3	1.97 V	347	35.4	2.3
7	#10380.00	46.2 PK	68.2	-22.0	1.64 V	212	34.2	12.0
8	15570.00	47.0 PK	74.0	-27.0	1.99 V	257	34.4	12.6
9	15570.00	35.9 AV	54.0	-18.1	1.99 V	257	23.3	12.6

REMARKS:

1. Emission Level(dBuV/m) = Raw Value(dBuV) + Correction Factor(dB/m)
2. Correction Factor(dB/m) = Antenna Factor(dB/m) + Cable Factor(dB) – Pre-Amplifier Factor(dB)
3. The other emission levels were very low against the limit.
4. Margin value = Emission Level – Limit value
5. " * ": Fundamental frequency.
6. " # ": The radiated frequency is out of the restricted band.

CHANNEL	TX Channel 46	DETECTOR FUNCTION	Peak (PK)
FREQUENCY RANGE	1GHz ~ 40GHz		Average (AV)

ANTENNA POLARITY & TEST DISTANCE: HORIZONTAL AT 3 M								
NO.	FREQ. (MHz)	EMISSION LEVEL (dBuV/m)	LIMIT (dBuV/m)	MARGIN (dB)	ANTENNA HEIGHT (m)	TABLE ANGLE (Degree)	RAW VALUE (dBuV)	CORRECTION FACTOR (dB/m)
1	*5230.00	116.2 PK			2.04 H	190	114.0	2.2
2	*5230.00	104.1 AV			2.04 H	190	101.9	2.2
3	5350.00	54.9 PK	74.0	-19.1	2.04 H	190	52.6	2.3
4	5350.00	44.4 AV	54.0	-9.6	2.04 H	190	42.1	2.3
5	#10460.00	43.9 PK	68.2	-24.3	1.68 H	354	31.5	12.4
6	15690.00	53.0 PK	74.0	-21.0	1.79 H	239	40.8	12.2
7	15690.00	40.2 AV	54.0	-13.8	1.79 H	239	28.0	12.2

ANTENNA POLARITY & TEST DISTANCE: VERTICAL AT 3 M								
NO.	FREQ. (MHz)	EMISSION LEVEL (dBuV/m)	LIMIT (dBuV/m)	MARGIN (dB)	ANTENNA HEIGHT (m)	TABLE ANGLE (Degree)	RAW VALUE (dBuV)	CORRECTION FACTOR (dB/m)
1	*5230.00	114.6 PK			2.02 V	360	112.4	2.2
2	*5230.00	102.8 AV			2.02 V	360	100.6	2.2
3	5350.00	47.8 PK	74.0	-26.2	2.02 V	360	45.5	2.3
4	5350.00	38.3 AV	54.0	-15.7	2.02 V	360	36.0	2.3
5	#10460.00	46.2 PK	68.2	-22.0	1.69 V	210	33.8	12.4
6	15690.00	47.8 PK	74.0	-26.2	2.00 V	237	35.6	12.2
7	15690.00	36.8 AV	54.0	-17.2	2.00 V	237	24.6	12.2

REMARKS:

1. Emission Level(dBuV/m) = Raw Value(dBuV) + Correction Factor(dB/m)
2. Correction Factor(dB/m) = Antenna Factor(dB/m) + Cable Factor(dB) – Pre-Amplifier Factor(dB)
3. The other emission levels were very low against the limit.
4. Margin value = Emission Level – Limit value
5. " * ": Fundamental frequency.
6. " # ": The radiated frequency is out of the restricted band.

CHANNEL	TX Channel 151	DETECTOR FUNCTION	Peak (PK)
FREQUENCY RANGE	1GHz ~ 40GHz		Average (AV)

ANTENNA POLARITY & TEST DISTANCE: HORIZONTAL AT 3 M								
NO.	FREQ. (MHz)	EMISSION LEVEL (dBuV/m)	LIMIT (dBuV/m)	MARGIN (dB)	ANTENNA HEIGHT (m)	TABLE ANGLE (Degree)	RAW VALUE (dBuV)	CORRECTION FACTOR (dB/m)
1	#5639.13	54.8 PK	68.2	-13.4	2.65 H	323	52.1	2.7
2	*5755.00	114.6 PK			2.65 H	323	111.6	3.0
3	*5755.00	102.4 AV			2.65 H	323	99.4	3.0
4	#5935.82	54.5 PK	68.2	-13.7	2.65 H	323	51.1	3.4
5	11510.00	44.5 PK	74.0	-29.5	1.59 H	355	32.2	12.3
6	11510.00	40.0 AV	54.0	-14.0	1.59 H	355	27.7	12.3
7	#17265.00	52.5 PK	68.2	-15.7	1.82 H	229	37.1	15.4

ANTENNA POLARITY & TEST DISTANCE: VERTICAL AT 3 M								
NO.	FREQ. (MHz)	EMISSION LEVEL (dBuV/m)	LIMIT (dBuV/m)	MARGIN (dB)	ANTENNA HEIGHT (m)	TABLE ANGLE (Degree)	RAW VALUE (dBuV)	CORRECTION FACTOR (dB/m)
1	#5606.58	55.8 PK	68.2	-12.4	1.61 V	350	53.0	2.8
2	*5755.00	115.4 PK			1.61 V	350	112.4	3.0
3	*5755.00	103.4 AV			1.61 V	350	100.4	3.0
4	#5959.91	53.5 PK	68.2	-14.7	1.61 V	350	50.3	3.2
5	11510.00	45.6 PK	74.0	-28.4	1.69 V	219	33.3	12.3
6	11510.00	35.3 AV	54.0	-18.7	1.69 V	219	23.0	12.3
7	#17265.00	47.3 PK	68.2	-20.9	2.00 V	236	31.9	15.4

REMARKS:

1. Emission Level(dBuV/m) = Raw Value(dBuV) + Correction Factor(dB/m)
2. Correction Factor(dB/m) = Antenna Factor(dB/m) + Cable Factor(dB) – Pre-Amplifier Factor(dB)
3. The other emission levels were very low against the limit.
4. Margin value = Emission Level – Limit value
5. " * ": Fundamental frequency.
6. " # ": The radiated frequency is out of the restricted band.

CHANNEL	TX Channel 159	DETECTOR FUNCTION	Peak (PK)
FREQUENCY RANGE	1GHz ~ 40GHz		Average (AV)

ANTENNA POLARITY & TEST DISTANCE: HORIZONTAL AT 3 M								
NO.	FREQ. (MHz)	EMISSION LEVEL (dBuV/m)	LIMIT (dBuV/m)	MARGIN (dB)	ANTENNA HEIGHT (m)	TABLE ANGLE (Degree)	RAW VALUE (dBuV)	CORRECTION FACTOR (dB/m)
1	#5594.23	54.1 PK	68.2	-14.1	1.19 H	163	51.3	2.8
2	*5795.00	115.2 PK			1.19 H	163	112.2	3.0
3	*5795.00	103.1 AV			1.19 H	163	100.1	3.0
4	#5980.41	53.4 PK	68.2	-14.8	1.19 H	163	50.2	3.2
5	11590.00	44.3 PK	74.0	-29.7	1.62 H	360	31.9	12.4
6	11590.00	40.2 AV	54.0	-13.8	1.62 H	360	27.8	12.4
7	#17385.00	53.2 PK	68.2	-15.0	1.81 H	222	37.0	16.2

ANTENNA POLARITY & TEST DISTANCE: VERTICAL AT 3 M								
NO.	FREQ. (MHz)	EMISSION LEVEL (dBuV/m)	LIMIT (dBuV/m)	MARGIN (dB)	ANTENNA HEIGHT (m)	TABLE ANGLE (Degree)	RAW VALUE (dBuV)	CORRECTION FACTOR (dB/m)
1	#5622.26	53.7 PK	68.2	-14.5	1.54 V	306	50.9	2.8
2	*5795.00	115.8 PK			1.54 V	306	112.8	3.0
3	*5795.00	103.7 AV			1.54 V	306	100.7	3.0
4	#5983.90	53.5 PK	68.2	-14.7	1.54 V	306	50.3	3.2
5	11590.00	46.4 PK	74.0	-27.6	1.70 V	210	34.0	12.4
6	11590.00	36.0 AV	54.0	-18.0	1.70 V	210	23.6	12.4
7	#17385.00	47.4 PK	68.2	-20.8	2.05 V	247	31.2	16.2

REMARKS:

1. Emission Level(dBuV/m) = Raw Value(dBuV) + Correction Factor(dB/m)
2. Correction Factor(dB/m) = Antenna Factor(dB/m) + Cable Factor(dB) – Pre-Amplifier Factor(dB)
3. The other emission levels were very low against the limit.
4. Margin value = Emission Level – Limit value
5. " * ": Fundamental frequency.
6. " # ": The radiated frequency is out of the restricted band.

802.11ax (HE80)

CHANNEL	TX Channel 42	DETECTOR FUNCTION	Peak (PK)
FREQUENCY RANGE	1GHz ~ 40GHz		Average (AV)

ANTENNA POLARITY & TEST DISTANCE: HORIZONTAL AT 3 M								
NO.	FREQ. (MHz)	EMISSION LEVEL (dBuV/m)	LIMIT (dBuV/m)	MARGIN (dB)	ANTENNA HEIGHT (m)	TABLE ANGLE (Degree)	RAW VALUE (dBuV)	CORRECTION FACTOR (dB/m)
1	5150.00	58.3 PK	74.0	-15.7	1.44 H	353	55.7	2.6
2	5150.00	45.4 AV	54.0	-8.6	1.44 H	353	42.8	2.6
3	*5210.00	112.1 PK			1.44 H	353	109.7	2.4
4	*5210.00	100.3 AV			1.44 H	353	97.9	2.4
5	5350.00	55.1 PK	74.0	-18.9	1.44 H	353	52.8	2.3
6	5350.00	44.4 AV	54.0	-9.6	1.44 H	353	42.1	2.3
7	#10420.00	44.7 PK	68.2	-23.5	1.63 H	356	32.5	12.2
8	15630.00	53.7 PK	74.0	-20.3	1.75 H	225	41.0	12.7
9	15630.00	40.6 AV	54.0	-13.4	1.75 H	225	27.9	12.7

ANTENNA POLARITY & TEST DISTANCE: VERTICAL AT 3 M								
NO.	FREQ. (MHz)	EMISSION LEVEL (dBuV/m)	LIMIT (dBuV/m)	MARGIN (dB)	ANTENNA HEIGHT (m)	TABLE ANGLE (Degree)	RAW VALUE (dBuV)	CORRECTION FACTOR (dB/m)
1	5150.00	58.2 PK	74.0	-15.8	2.97 V	358	55.6	2.6
2	5150.00	44.4 AV	54.0	-9.6	2.97 V	358	41.8	2.6
3	*5210.00	110.5 PK			2.97 V	358	108.1	2.4
4	*5210.00	99.0 AV			2.97 V	358	96.6	2.4
5	5350.00	48.0 PK	74.0	-26.0	2.97 V	358	45.7	2.3
6	5350.00	38.3 AV	54.0	-15.7	2.97 V	358	36.0	2.3
7	#10420.00	45.6 PK	68.2	-22.6	1.68 V	203	33.4	12.2
8	15630.00	47.3 PK	74.0	-26.7	2.02 V	254	34.6	12.7
9	15630.00	36.0 AV	54.0	-18.0	2.02 V	254	23.3	12.7

REMARKS:

1. Emission Level(dBuV/m) = Raw Value(dBuV) + Correction Factor(dB/m)
2. Correction Factor(dB/m) = Antenna Factor(dB/m) + Cable Factor(dB) – Pre-Amplifier Factor(dB)
3. The other emission levels were very low against the limit.
4. Margin value = Emission Level – Limit value
5. " * ": Fundamental frequency.
6. " # ": The radiated frequency is out of the restricted band.

CHANNEL	TX Channel 155	DETECTOR FUNCTION	Peak (PK)
FREQUENCY RANGE	1GHz ~ 40GHz		Average (AV)

ANTENNA POLARITY & TEST DISTANCE: HORIZONTAL AT 3 M								
NO.	FREQ. (MHz)	EMISSION LEVEL (dBuV/m)	LIMIT (dBuV/m)	MARGIN (dB)	ANTENNA HEIGHT (m)	TABLE ANGLE (Degree)	RAW VALUE (dBuV)	CORRECTION FACTOR (dB/m)
1	#5643.36	57.6 PK	68.2	-10.6	1.45 H	343	54.9	2.7
2	*5775.00	111.9 PK			1.45 H	343	108.9	3.0
3	*5775.00	100.1 AV			1.45 H	343	97.1	3.0
4	#5935.88	54.2 PK	68.2	-14.0	1.45 H	343	50.8	3.4
5	11550.00	44.3 PK	74.0	-29.7	1.62 H	347	31.9	12.4
6	11550.00	40.2 AV	54.0	-13.8	1.62 H	347	27.8	12.4
7	#17325.00	52.9 PK	68.2	-15.3	1.73 H	249	37.2	15.7

ANTENNA POLARITY & TEST DISTANCE: VERTICAL AT 3 M								
NO.	FREQ. (MHz)	EMISSION LEVEL (dBuV/m)	LIMIT (dBuV/m)	MARGIN (dB)	ANTENNA HEIGHT (m)	TABLE ANGLE (Degree)	RAW VALUE (dBuV)	CORRECTION FACTOR (dB/m)
1	#5628.51	54.9 PK	68.2	-13.3	2.97 V	348	52.1	2.8
2	*5775.00	113.6 PK			2.97 V	348	110.6	3.0
3	*5775.00	102.0 AV			2.97 V	348	99.0	3.0
4	#5938.88	54.4 PK	68.2	-13.8	2.97 V	348	51.0	3.4
5	11550.00	46.7 PK	74.0	-27.3	1.71 V	205	34.3	12.4
6	11550.00	36.1 AV	54.0	-17.9	1.71 V	205	23.7	12.4
7	#17325.00	47.2 PK	68.2	-21.0	1.96 V	231	31.5	15.7

REMARKS:

1. Emission Level(dBuV/m) = Raw Value(dBuV) + Correction Factor(dB/m)
2. Correction Factor(dB/m) = Antenna Factor(dB/m) + Cable Factor(dB) – Pre-Amplifier Factor(dB)
3. The other emission levels were very low against the limit.
4. Margin value = Emission Level – Limit value
5. " * ": Fundamental frequency.
6. " # ": The radiated frequency is out of the restricted band.

802.11ax (HE80+80)

CHANNEL	TX Channel 42+155	DETECTOR FUNCTION	Peak (PK)
FREQUENCY RANGE	1GHz ~ 40GHz		Average (AV)

ANTENNA POLARITY & TEST DISTANCE: HORIZONTAL AT 3 M								
NO.	FREQ. (MHz)	EMISSION LEVEL (dBuV/m)	LIMIT (dBuV/m)	MARGIN (dB)	ANTENNA HEIGHT (m)	TABLE ANGLE (Degree)	RAW VALUE (dBuV)	CORRECTION FACTOR (dB/m)
1	5150.00	58.0 PK	74.0	-16.0	1.45 H	352	55.4	2.6
2	5150.00	45.2 AV	54.0	-8.8	1.45 H	352	42.6	2.6
3	*5210.00	111.4 PK			1.45 H	352	109.0	2.4
4	*5210.00	99.9 AV			1.45 H	352	97.5	2.4
5	5350.00	55.3 PK	74.0	-18.7	1.45 H	352	53.0	2.3
6	5350.00	44.6 AV	54.0	-9.4	1.45 H	352	42.3	2.3
7	#5641.40	56.1 PK	68.2	-12.1	1.50 H	155	53.4	2.7
8	*5775.00	111.5 PK			1.50 H	155	108.5	3.0
9	*5775.00	99.8 AV			1.50 H	155	96.8	3.0
10	#5942.78	54.4 PK	68.2	-13.8	1.50 H	155	51.1	3.3
11	#10420.00	44.7 PK	68.2	-23.5	1.60 H	340	32.5	12.2
12	11550.00	45.0 PK	74.0	-29.0	1.64 H	348	32.6	12.4
13	11550.00	40.7 AV	54.0	-13.3	1.64 H	348	28.3	12.4
14	15630.00	54.0 PK	74.0	-20.0	1.73 H	213	41.3	12.7
15	15630.00	40.6 AV	54.0	-13.4	1.73 H	213	27.9	12.7
16	#17325.00	53.1 PK	68.2	-15.1	1.77 H	212	37.4	15.7

ANTENNA POLARITY & TEST DISTANCE: VERTICAL AT 3 M								
NO.	FREQ. (MHz)	EMISSION LEVEL (dBuV/m)	LIMIT (dBuV/m)	MARGIN (dB)	ANTENNA HEIGHT (m)	TABLE ANGLE (Degree)	RAW VALUE (dBuV)	CORRECTION FACTOR (dB/m)
1	5150.00	58.2 PK	74.0	-15.8	3.03 V	360	55.6	2.6
2	5150.00	44.5 AV	54.0	-9.5	3.03 V	360	41.9	2.6
3	*5210.00	110.8 PK			3.03 V	360	108.4	2.4
4	*5210.00	99.4 AV			3.03 V	360	97.0	2.4
5	5350.00	48.7 PK	74.0	-25.3	3.03 V	360	46.4	2.3
6	5350.00	38.7 AV	54.0	-15.3	3.03 V	360	36.4	2.3
7	#5607.85	57.3 PK	68.2	-10.9	1.49 V	114	54.5	2.8
8	*5775.00	112.2 PK			1.49 V	114	109.2	3.0
9	*5775.00	100.7 AV			1.49 V	114	97.7	3.0
10	#5932.21	55.0 PK	68.2	-13.2	1.49 V	114	51.6	3.4
11	#10420.00	45.4 PK	68.2	-22.8	1.65 V	193	33.2	12.2
12	11550.00	45.6 PK	74.0	-28.4	1.70 V	199	33.2	12.4
13	11550.00	35.6 AV	54.0	-18.4	1.70 V	199	23.2	12.4
14	15630.00	47.1 PK	74.0	-26.9	2.03 V	267	34.4	12.7
15	15630.00	35.6 AV	54.0	-18.4	2.03 V	267	22.9	12.7
16	#17325.00	47.0 PK	68.2	-21.2	2.04 V	253	31.3	15.7

REMARKS:

1. Emission Level(dBuV/m) = Raw Value(dBuV) + Correction Factor(dB/m)
2. Correction Factor(dB/m) = Antenna Factor(dB/m) + Cable Factor(dB) – Pre-Amplifier Factor(dB)
3. The other emission levels were very low against the limit.
4. Margin value = Emission Level – Limit value
5. " * ": Fundamental frequency.
6. " # ": The radiated frequency is out of the restricted band.

Below 1GHz Data:

802.11ax (HE20)

CHANNEL	TX Channel 48	DETECTOR FUNCTION	Quasi-Peak (QP)
FREQUENCY RANGE	9kHz ~ 1GHz		

ANTENNA POLARITY & TEST DISTANCE: HORIZONTAL AT 3 M

NO.	FREQ. (MHz)	EMISSION LEVEL (dBuV/m)	LIMIT (dBuV/m)	MARGIN (dB)	ANTENNA HEIGHT (m)	TABLE ANGLE (Degree)	RAW VALUE (dBuV)	CORRECTION FACTOR (dB/m)
1	84.15	33.1 QP	40.0	-6.9	1.00 H	263	46.5	-13.4
2	119.40	37.8 QP	43.5	-5.7	1.50 H	244	47.5	-9.7
3	137.25	37.6 QP	43.5	-5.9	1.00 H	156	45.9	-8.3
4	180.14	34.3 QP	43.5	-9.2	1.50 H	228	43.6	-9.3
5	249.99	38.4 QP	46.0	-7.6	1.50 H	207	47.4	-9.0
6	318.97	37.2 QP	46.0	-8.8	1.00 H	305	43.4	-6.2

REMARKS:

1. Emission Level(dBuV/m) = Raw Value(dBuV) + Correction Factor(dB/m)
2. Correction Factor(dB/m) = Antenna Factor(dB/m) + Cable Factor(dB) – Pre-Amplifier Factor(dB)
3. Margin value = Emission Level – Limit value
4. The emission levels were very low against the limit of frequency range 9kHz~30MHz: the amplitude of spurious emissions attenuated more than 20 dB below the permissible value to be report.

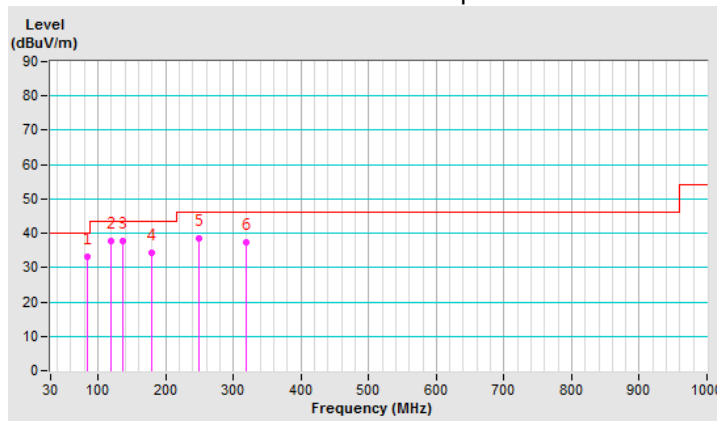

CHANNEL	TX Channel 48	DETECTOR FUNCTION	Quasi-Peak (QP)
FREQUENCY RANGE	9kHz ~ 1GHz		

ANTENNA POLARITY & TEST DISTANCE: VERTICAL AT 3 M								
NO.	FREQ. (MHz)	EMISSION LEVEL (dBuV/m)	LIMIT (dBuV/m)	MARGIN (dB)	ANTENNA HEIGHT (m)	TABLE ANGLE (Degree)	RAW VALUE (dBuV)	CORRECTION FACTOR (dB/m)
1	37.76	36.6 QP	40.0	-3.4	1.50 V	141	45.1	-8.5
2	123.38	37.7 QP	43.5	-5.8	1.00 V	244	47.1	-9.4
3	132.96	37.5 QP	43.5	-6.0	1.00 V	172	46.3	-8.8
4	247.33	36.6 QP	46.0	-9.4	1.00 V	145	45.7	-9.1
5	288.63	41.8 QP	46.0	-4.2	1.50 V	101	49.1	-7.3
6	358.69	41.7 QP	46.0	-4.3	1.50 V	264	47.2	-5.5

REMARKS:

1. Emission Level(dBuV/m) = Raw Value(dBuV) + Correction Factor(dB/m)
2. Correction Factor(dB/m) = Antenna Factor(dB/m) + Cable Factor(dB) – Pre-Amplifier Factor(dB)
3. Margin value = Emission Level – Limit value
4. The emission levels were very low against the limit of frequency range 9kHz~30MHz: the amplitude of spurious emissions attenuated more than 20 dB below the permissible value to be report.

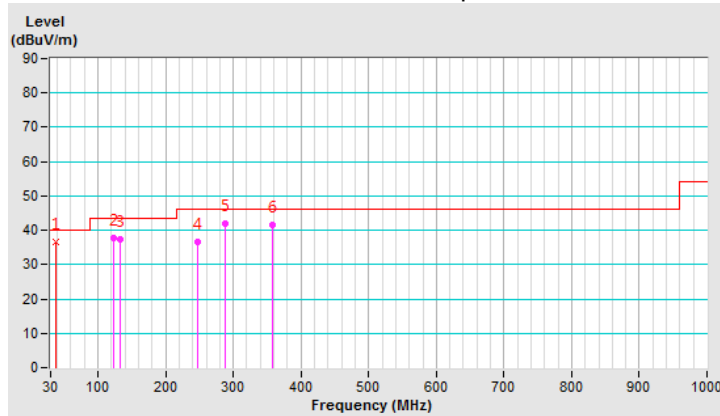

4.2 Conducted Emission Measurement

4.2.1 Limits of Conducted Emission Measurement

Frequency (MHz)	Conducted Limit (dBuV)	
	Quasi-peak	Average
0.15 - 0.5	66 - 56	56 - 46
0.50 - 5.0	56	46
5.0 - 30.0	60	50

- Note: 1. The lower limit shall apply at the transition frequencies.
 2. The limit decreases in line with the logarithm of the frequency in the range of 0.15 to 0.50MHz.

4.2.2 Test Instruments

DESCRIPTION & MANUFACTURER	MODEL NO.	SERIAL NO.	CALIBRATED DATE	CALIBRATED UNTIL
Test Receiver R&S	ESCS 30	847124/029	Oct. 24, 2018	Oct. 23, 2019
Line-Impedance Stabilization Network (for EUT) R&S	ESH3-Z5	848773/004	Oct. 22, 2018	Oct. 21, 2019
Line-Impedance Stabilization Network (for Peripheral) R&S	ENV216	100072	June 04, 2018	June 03, 2019
50 ohms Terminator	N/A	3	Oct. 22, 2018	Oct. 21, 2019
RF Cable	5D-FB	COCCAB-001	Sep. 28, 2018	Sep. 27, 2019
Fixed attenuator EMCI	STI02-2200-10	003	Mar. 16, 2018	Mar. 15, 2019
Software BVADT	BVADT_Cond_ V7.3.7.4	NA	NA	NA

Note:

- The calibration interval of the above test instruments are 12 months and the calibrations are traceable to NML/ROC and NIST/USA.
- The test was performed in Conduction 1.
- Tested Date: Dec. 07, 2018

4.2.3 Test Procedure

- The EUT was placed 0.4 meters from the conducting wall of the shielded room with EUT being connected to the power mains through a line impedance stabilization network (LISN). Other support units were connected to the power mains through another LISN. The two LISNs provide 50 ohm/ 50uH of coupling impedance for the measuring instrument.
- Both lines of the power mains connected to the EUT were checked for maximum conducted interference.
- The frequency range from 150kHz to 30MHz was searched. Emission levels under (Limit - 20dB) was not recorded.

NOTE: All modes of operation were investigated and the worst-case emissions are reported.

4.2.4 Deviation from Test Standard

No deviation.

4.2.5 Test Setup

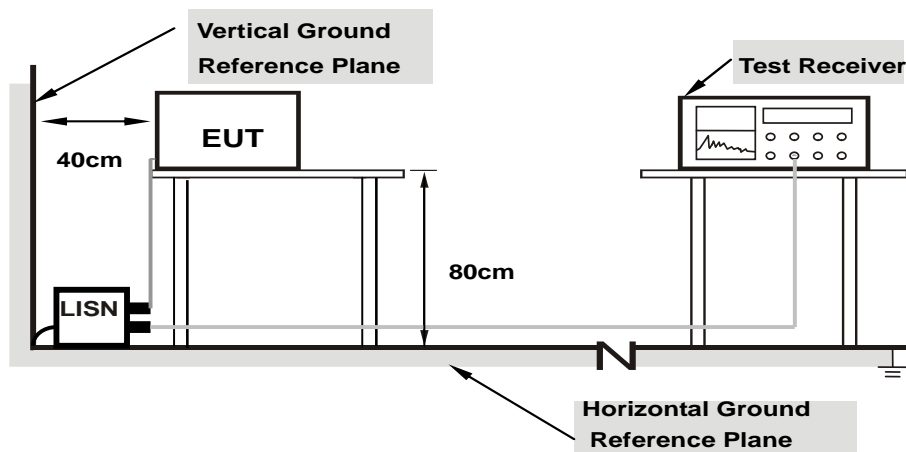

Note: 1.Support units were connected to second LISN.

For the actual test configuration, please refer to the attached file (Test Setup Photo).

4.2.6 EUT Operating Condition

Same as 4.1.6.

4.2.7 Test Results

Phase	Line (L)	Detector Function	Quasi-Peak (QP) / Average (AV)
-------	----------	-------------------	--------------------------------

No	Freq. [MHz]	Corr.	Reading Value		Emission Level		Limit		Margin	
		Factor	[dB (uV)]		[dB (uV)]		[dB (uV)]		(dB)	
	(dB)	Q.P.	AV.	Q.P.	AV.	Q.P.	AV.	Q.P.	AV.	
1	0.15000	10.02	32.59	16.07	42.61	26.09	66.00	56.00	-23.39	-29.91
2	0.20078	10.04	25.47	10.67	35.51	20.71	63.58	53.58	-28.07	-32.87
3	0.40391	10.07	32.21	24.33	42.28	34.40	57.77	47.77	-15.49	-13.37
4	0.86094	10.10	19.57	9.70	29.67	19.80	56.00	46.00	-26.33	-26.20
5	2.66016	10.19	14.15	2.17	24.34	12.36	56.00	46.00	-31.66	-33.64
6	12.98828	10.69	10.08	1.50	20.77	12.19	60.00	50.00	-39.23	-37.81

REMARKS:

1. Q.P. and AV. are abbreviations of quasi-peak and average individually.
2. The emission levels of other frequencies were very low against the limit.
3. Margin value = Emission level - Limit value
4. Correction factor = Insertion loss + Cable loss
5. Emission Level = Correction Factor + Reading Value.

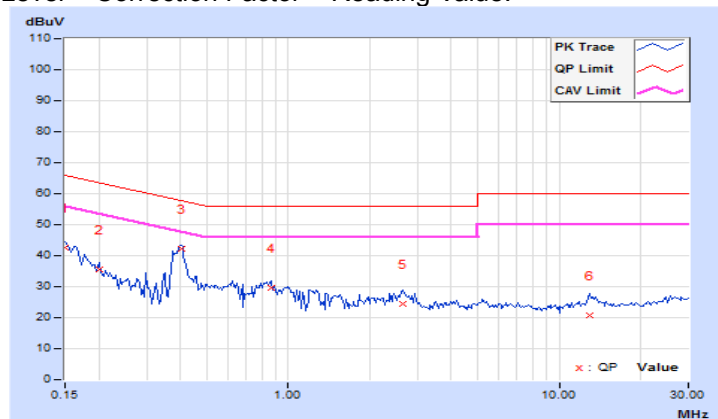

Phase	Neutral (N)	Detector Function	Quasi-Peak (QP) / Average (AV)
-------	-------------	-------------------	--------------------------------

No	Freq. [MHz]	Corr.	Reading Value		Emission Level		Limit		Margin	
		Factor	[dB (uV)]		[dB (uV)]		[dB (uV)]		(dB)	
	(dB)	Q.P.	AV.	Q.P.	AV.	Q.P.	AV.	Q.P.	AV.	
1	0.15000	9.93	32.92	15.46	42.85	25.39	66.00	56.00	-23.15	-30.61
2	0.20859	9.94	23.54	8.58	33.48	18.52	63.26	53.26	-29.78	-34.74
3	0.40000	9.96	32.45	28.33	42.41	38.29	57.85	47.85	-15.44	-9.56
4	0.67344	9.97	18.95	12.31	28.92	22.28	56.00	46.00	-27.08	-23.72
5	2.51953	10.06	18.32	11.28	28.38	21.34	56.00	46.00	-27.62	-24.66
6	24.36719	10.91	10.02	3.91	20.93	14.82	60.00	50.00	-39.07	-35.18

REMARKS:

1. Q.P. and AV. are abbreviations of quasi-peak and average individually.
2. The emission levels of other frequencies were very low against the limit.
3. Margin value = Emission level - Limit value
4. Correction factor = Insertion loss + Cable loss
5. Emission Level = Correction Factor + Reading Value.



4.3 Transmit Power Measurement

4.3.1 Limits of Transmit Power Measurement

Operation Band	EUT Category		Limit
U-NII-1		Outdoor Access Point	1 Watt (30 dBm) (Max. e.i.r.p \leq 125mW(21 dBm) at any elevation angle above 30 degrees as measured from the horizon)
		Fixed point-to-point Access Point	1 Watt (30 dBm)
	√	Indoor Access Point	1 Watt (30 dBm)
	√	Client device	250mW (24 dBm)
U-NII-2A			250mW (24 dBm) or 11 dBm+10 log B*
U-NII-2C			250mW (24 dBm) or 11 dBm+10 log B*
U-NII-3		√	1 Watt (30 dBm)

*B is the 26 dB emission bandwidth in megahertz

Note: This device can support different category application which switched by access point mode and client mode by software.

Per KDB 662911 Method of conducted output power measurement on IEEE 802.11 devices,

Array Gain = 0 dB (i.e., no array gain) for $N_{ANT} \leq 4$;

Array Gain = 0 dB (i.e., no array gain) for channel widths ≥ 40 MHz for any N_{ANT} ;

Array Gain = $5 \log(N_{ANT}/N_{SS})$ dB or 3 dB, whichever is less for 20-MHz channel widths with $N_{ANT} \geq 5$.

For power measurements on all other devices: Array Gain = $10 \log(N_{ANT}/N_{SS})$ dB.

4.3.2 Test Setup

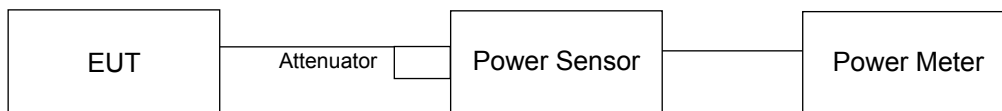

4.3.3 Test Instruments

Refer to section 4.1.2 to get information of above instrument.

4.3.4 Test Procedure

Method PM is used to perform output power measurement, trigger and gating function of wide band power meter is enabled to measure max output power of TX on burst. Duty factor is not added to measured value.

4.3.5 Deviation from Test Standard

No deviation.

4.3.6 EUT Operating Condition

The software provided by client to enable the EUT under transmission condition continuously at lowest, middle and highest channel frequencies individually.

4.3.7 Test Results

Master Mode

For U-NII-1:

Non-Beamforming Mode

802.11a

Chan.	Freq. (MHz)	Maximum Conducted Power (dBm)								Total Power (mW)	Total Power (dBm)	Limit (dBm)	Pass / Fail
		Chain 0	Chain 1	Chain 2	Chain 3	Chain 4	Chain 5	Chain 6	Chain 7				
36	5180	16.33	16.21	17.31	17.12	16.64	17.22	17.06	17.62	397.567	25.99	26.30	Pass
40	5200	16.35	16.28	17.34	17.20	16.71	17.32	17.11	17.72	403.688	26.06	26.30	Pass
48	5240	16.36	16.31	17.38	17.25	16.82	17.4	17.21	17.79	409.555	26.12	26.30	Pass

Note: 1. Directional gain is 9.7dBi > 6dBi, so the power limit shall be reduced to $30-(9.7-6) = 26.30$ dBm.

802.11ac (VHT20)

Chan.	Freq. (MHz)	Maximum Conducted Power (dBm)								Total Power (mW)	Total Power (dBm)	Limit (dBm)	Pass / Fail
		Chain 0	Chain 1	Chain 2	Chain 3	Chain 4	Chain 5	Chain 6	Chain 7				
36	5180	16.41	16.15	17.25	17.11	16.68	17.21	16.97	17.55	395.274	25.97	26.30	Pass
40	5200	16.38	16.21	17.21	17.19	16.61	17.28	17.06	17.61	397.959	26.00	26.30	Pass
48	5240	16.51	16.26	17.31	17.22	16.79	17.32	17.11	17.65	404.907	26.07	26.30	Pass

Note: 1. Directional gain is 9.7dBi > 6dBi, so the power limit shall be reduced to $30-(9.7-6) = 26.30$ dBm.

802.11ac (VHT40)

Chan.	Freq. (MHz)	Maximum Conducted Power (dBm)								Total Power (mW)	Total Power (dBm)	Limit (dBm)	Pass / Fail
		Chain 0	Chain 1	Chain 2	Chain 3	Chain 4	Chain 5	Chain 6	Chain 7				
38	5190	16.28	16.25	17.29	17.13	16.64	17.11	17.15	17.58	396.549	25.98	26.30	Pass
46	5230	16.41	16.23	17.25	17.21	16.53	17.18	17.12	17.63	398.102	26.00	26.30	Pass

Note: 1. Directional gain is 9.7dBi > 6dBi, so the power limit shall be reduced to $30-(9.7-6) = 26.30$ dBm.

802.11ac (VHT80)

Chan.	Freq. (MHz)	Maximum Conducted Power (dBm)								Total Power (mW)	Total Power (dBm)	Limit (dBm)	Pass / Fail
		Chain 0	Chain 1	Chain 2	Chain 3	Chain 4	Chain 5	Chain 6	Chain 7				
42	5210	15.68	15.69	16.46	16.42	15.58	16.44	16.33	16.95	334.858	25.25	26.30	Pass

Note: 1. Directional gain is 9.7dBi > 6dBi, so the power limit shall be reduced to $30-(9.7-6) = 26.30$ dBm.

802.11ac (VHT80+80)

Chan.	Freq. (MHz)	Maximum Conducted Power (dBm)								Total Power (mW)	Total Power (dBm)	Limit (dBm)	Pass / Fail
		Chain 0	Chain 1	Chain 2	Chain 3	Chain 4	Chain 5	Chain 6	Chain 7				
42+155	5210	18.68	18.45	19.12	19.54	-	-	-	-	315.383	24.99	26.30	Pass
	5775	Test results refer to U_NII-3 data											

Note: 1. Directional gain is 9.7dBi > 6dBi, so the power limit shall be reduced to $30 - (9.7 - 6) = 26.30\text{dBm}$.

802.11ax (HE20)

Chan.	Freq. (MHz)	Maximum Conducted Power (dBm)								Total Power (mW)	Total Power (dBm)	Limit (dBm)	Pass / Fail
		Chain 0	Chain 1	Chain 2	Chain 3	Chain 4	Chain 5	Chain 6	Chain 7				
36	5180	16.74	16.66	17.58	16.33	16.56	17.25	16.88	17.68	399.529	26.02	26.30	Pass
40	5200	16.71	16.68	17.68	16.36	16.57	17.18	16.88	17.67	400.171	26.02	26.30	Pass
48	5240	16.85	16.82	17.73	16.42	16.69	17.1	17.89	17.78	419.096	26.22	26.30	Pass

Note: 1. Directional gain is 9.7dBi > 6dBi, so the power limit shall be reduced to $30-(9.7-6) = 26.30$ dBm.

802.11ax (HE40)

Chan.	Freq. (MHz)	Maximum Conducted Power (dBm)								Total Power (mW)	Total Power (dBm)	Limit (dBm)	Pass / Fail
		Chain 0	Chain 1	Chain 2	Chain 3	Chain 4	Chain 5	Chain 6	Chain 7				
38	5190	16.65	16.71	17.73	16.11	16.42	17.39	17.04	17.75	402.073	26.04	26.30	Pass
46	5230	16.71	16.83	17.72	16.23	16.45	17.03	17.08	17.82	402.416	26.05	26.30	Pass

Note: 1. Directional gain is 9.7dBi > 6dBi, so the power limit shall be reduced to $30-(9.7-6) = 26.30$ dBm.

802.11ax (HE80)

Chan.	Freq. (MHz)	Maximum Conducted Power (dBm)								Total Power (mW)	Total Power (dBm)	Limit (dBm)	Pass / Fail
		Chain 0	Chain 1	Chain 2	Chain 3	Chain 4	Chain 5	Chain 6	Chain 7				
42	5210	16.25	16.36	17.19	15.82	16.24	16.67	16.22	17.03	356.845	25.52	26.30	Pass

Note: 1. Directional gain is 9.7dBi > 6dBi, so the power limit shall be reduced to $30-(9.7-6) = 26.30$ dBm.

802.11ax (HE80+80)

Chan.	Freq. (MHz)	Maximum Conducted Power (dBm)								Total Power (mW)	Total Power (dBm)	Limit (dBm)	Pass / Fail
		Chain 0	Chain 1	Chain 2	Chain 3	Chain 4	Chain 5	Chain 6	Chain 7				
42+155	5210	18.55	19.33	18.50	19.48	-	-	-	-	316.828	25.01	26.30	Pass
	5775	Test results refer to U_NII-3 data											

Note: 1. Directional gain is 9.7dBi > 6dBi, so the power limit shall be reduced to $30-(9.7-6) = 26.30$ dBm.

Beamforming Mode

802.11ac (VHT20)

Chan.	Freq. (MHz)	Maximum Conducted Power (dBm)								Total Power (mW)	Total Power (dBm)	Limit (dBm)	Pass / Fail
		Chain 0	Chain 1	Chain 2	Chain 3	Chain 4	Chain 5	Chain 6	Chain 7				
36	5180	16.41	16.15	17.25	17.11	16.68	17.21	16.97	17.55	395.274	25.97	26.30	Pass
40	5200	16.38	16.21	17.21	17.19	16.61	17.28	17.06	17.61	397.959	26.00	26.30	Pass
48	5240	16.51	16.26	17.31	17.22	16.79	17.32	17.11	17.65	404.907	26.07	26.30	Pass

Note: 1. Directional gain is 9.7dBi > 6dBi, so the power limit shall be reduced to $30-(9.7-6) = 26.30$ dBm.

802.11ac (VHT40)

Chan.	Freq. (MHz)	Maximum Conducted Power (dBm)								Total Power (mW)	Total Power (dBm)	Limit (dBm)	Pass / Fail
		Chain 0	Chain 1	Chain 2	Chain 3	Chain 4	Chain 5	Chain 6	Chain 7				
38	5190	16.28	16.25	17.29	17.13	16.64	17.11	17.15	17.58	396.549	25.98	26.30	Pass
46	5230	16.41	16.23	17.25	17.21	16.53	17.18	17.12	17.63	398.102	26.00	26.30	Pass

Note: 1. Directional gain is 9.7dBi > 6dBi, so the power limit shall be reduced to $30-(9.7-6) = 26.30$ dBm.

802.11ac (VHT80)

Chan.	Freq. (MHz)	Maximum Conducted Power (dBm)								Total Power (mW)	Total Power (dBm)	Limit (dBm)	Pass / Fail
		Chain 0	Chain 1	Chain 2	Chain 3	Chain 4	Chain 5	Chain 6	Chain 7				
42	5210	15.68	15.69	16.46	16.42	15.58	16.44	16.33	16.95	334.858	25.25	26.30	Pass

Note: 1. Directional gain is 9.7dBi > 6dBi, so the power limit shall be reduced to $30-(9.7-6) = 26.30$ dBm.

802.11ac (VHT80+80)

Chan.	Freq. (MHz)	Maximum Conducted Power (dBm)								Total Power (mW)	Total Power (dBm)	Limit (dBm)	Pass / Fail
		Chain 0	Chain 1	Chain 2	Chain 3	Chain 4	Chain 5	Chain 6	Chain 7				
42+155	5210	18.68	18.45	19.12	19.54	-	-	-	-	315.383	24.99	26.30	Pass
	5775	Test results refer to U_NII-3 data											

Note: 1. Directional gain is 9.7dBi > 6dBi, so the power limit shall be reduced to $30-(9.7-6) = 26.30$ dBm.

802.11ax (HE20)

Chan.	Freq. (MHz)	Maximum Conducted Power (dBm)								Total Power (mW)	Total Power (dBm)	Limit (dBm)	Pass / Fail
		Chain 0	Chain 1	Chain 2	Chain 3	Chain 4	Chain 5	Chain 6	Chain 7				
36	5180	16.74	16.66	17.58	16.33	16.56	17.25	16.88	17.68	399.529	26.02	26.30	Pass
40	5200	16.71	16.68	17.68	16.36	16.57	17.18	16.88	17.67	400.171	26.02	26.30	Pass
48	5240	16.85	16.82	17.73	16.42	16.69	17.1	17.89	17.78	419.096	26.22	26.30	Pass

Note: 1. Directional gain is 9.7dBi > 6dBi, so the power limit shall be reduced to $30-(9.7-6) = 26.30$ dBm.

802.11ax (HE40)

Chan.	Freq. (MHz)	Maximum Conducted Power (dBm)								Total Power (mW)	Total Power (dBm)	Limit (dBm)	Pass / Fail
		Chain 0	Chain 1	Chain 2	Chain 3	Chain 4	Chain 5	Chain 6	Chain 7				
38	5190	16.65	16.71	17.73	16.11	16.42	17.39	17.04	17.75	402.073	26.04	26.30	Pass
46	5230	16.71	16.83	17.72	16.23	16.45	17.03	17.08	17.82	402.416	26.05	26.30	Pass

Note: 1. Directional gain is 9.7dBi > 6dBi, so the power limit shall be reduced to $30-(9.7-6) = 26.30$ dBm.

802.11ax (HE80)

Chan.	Freq. (MHz)	Maximum Conducted Power (dBm)								Total Power (mW)	Total Power (dBm)	Limit (dBm)	Pass / Fail
		Chain 0	Chain 1	Chain 2	Chain 3	Chain 4	Chain 5	Chain 6	Chain 7				
42	5210	16.25	16.36	17.19	15.82	16.24	16.67	16.22	17.03	356.845	25.52	26.30	Pass

Note: 1. Directional gain is 9.7dBi > 6dBi, so the power limit shall be reduced to $30-(9.7-6) = 26.30$ dBm.

802.11ax (HE80+80)

Chan.	Freq. (MHz)	Maximum Conducted Power (dBm)								Total Power (mW)	Total Power (dBm)	Limit (dBm)	Pass / Fail
		Chain 0	Chain 1	Chain 2	Chain 3	Chain 4	Chain 5	Chain 6	Chain 7				
42+155	5210	18.55	19.33	18.50	19.48	-	-	-	-	316.828	25.01	26.30	Pass
	5775	Test results refer to U_NII-3 data											

Note: 1. Directional gain is 9.7dBi > 6dBi, so the power limit shall be reduced to $30-(9.7-6) = 26.30$ dBm.

For U-NII-3:

Non-Beamforming Mode

802.11a

Chan.	Freq. (MHz)	Maximum Conducted Power (dBm)								Total Power (mW)	Total Power (dBm)	Limit (dBm)	Pass / Fail
		Chain 0	Chain 1	Chain 2	Chain 3	Chain 4	Chain 5	Chain 6	Chain 7				
149	5745	16.35	16.01	16.39	16.54	16.11	16.75	16.89	17.11	360.104	25.56	25.73	Pass
157	5785	16.34	15.96	16.45	16.50	16.24	16.9	16.85	17.18	363.031	25.60	25.73	Pass
165	5825	16.32	15.91	16.54	16.48	16.33	16.93	16.74	17.23	363.716	25.61	25.73	Pass

Note: 1. Directional gain is 10.27dB > 6dBi, so the power limit shall be reduced to 30-(10.27-6) = 25.73dBm.

802.11ac (VHT20)

Chan.	Freq. (MHz)	Maximum Conducted Power (dBm)								Total Power (mW)	Total Power (dBm)	Limit (dBm)	Pass / Fail
		Chain 0	Chain 1	Chain 2	Chain 3	Chain 4	Chain 5	Chain 6	Chain 7				
149	5745	15.91	16.03	16.83	16.81	16.33	16.75	16.71	16.92	361.603	25.58	25.73	Pass
157	5785	16.06	16.14	16.89	16.82	16.45	16.81	16.7	16.89	366.198	25.64	25.73	Pass
165	5825	16.05	16.12	16.86	16.78	16.41	16.75	16.76	16.98	365.75	25.63	25.73	Pass

Note: 1. Directional gain is 10.27dB > 6dBi, so the power limit shall be reduced to 30-(10.27-6) = 25.73dBm.

802.11ac (VHT40)

Chan.	Freq. (MHz)	Maximum Conducted Power (dBm)								Total Power (mW)	Total Power (dBm)	Limit (dBm)	Pass / Fail
		Chain 0	Chain 1	Chain 2	Chain 3	Chain 4	Chain 5	Chain 6	Chain 7				
151	5755	16.30	16.05	16.75	16.53	16.45	16.79	16.42	17.02	361.336	25.58	25.73	Pass
159	5795	16.12	16.01	16.66	16.75	16.32	16.96	16.88	16.89	364.621	25.62	25.73	Pass

Note: 1. Directional gain is 10.27dB > 6dBi, so the power limit shall be reduced to 30-(10.27-6) = 25.73dBm.

802.11ac (VHT80)

Chan.	Freq. (MHz)	Maximum Conducted Power (dBm)								Total Power (mW)	Total Power (dBm)	Limit (dBm)	Pass / Fail
		Chain 0	Chain 1	Chain 2	Chain 3	Chain 4	Chain 5	Chain 6	Chain 7				
155	5775	16.09	15.97	16.57	16.84	16.31	16.85	16.78	16.97	362.471	25.59	25.73	Pass

Note: 1. Directional gain is 10.27dB > 6dBi, so the power limit shall be reduced to $30-(10.27-6) = 25.73\text{dBm}$.

802.11ac (VHT80+80)

Chan.	Freq. (MHz)	Maximum Conducted Power (dBm)								Total Power (mW)	Total Power (dBm)	Limit (dBm)	Pass / Fail
		Chain 0	Chain 1	Chain 2	Chain 3	Chain 4	Chain 5	Chain 6	Chain 7				
42+155	5210	Test results refer to U_NII-1 data											
	5775	-	-	-	-	18.56	19.75	19.87	19.86	360.064	25.56	25.73	Pass

Note: 1. Directional gain is 10.27dB > 6dBi, so the power limit shall be reduced to $30-(10.27-6) = 25.73\text{dBm}$.

802.11ax (HE20)

Chan.	Freq. (MHz)	Maximum Conducted Power (dBm)								Total Power (mW)	Total Power (dBm)	Limit (dBm)	Pass / Fail
		Chain 0	Chain 1	Chain 2	Chain 3	Chain 4	Chain 5	Chain 6	Chain 7				
149	5745	16.33	16.49	17.02	16.72	16.61	16.48	16.58	16.58	366.134	25.64	25.73	Pass
157	5785	16.22	16.32	16.91	16.54	16.43	16.8	16.8	16.8	366.45	25.64	25.73	Pass
165	5825	16.24	16.40	16.84	16.59	16.37	16.74	16.82	16.82	366.359	25.64	25.73	Pass

Note: 1. Directional gain is 10.27dB > 6dBi, so the power limit shall be reduced to $30-(10.27-6) = 25.73$ dBm.

802.11ax (HE40)

Chan.	Freq. (MHz)	Maximum Conducted Power (dBm)								Total Power (mW)	Total Power (dBm)	Limit (dBm)	Pass / Fail
		Chain 0	Chain 1	Chain 2	Chain 3	Chain 4	Chain 5	Chain 6	Chain 7				
151	5755	16.30	16.37	16.76	16.52	16.43	16.67	16.67	17.07	366.098	25.64	25.73	Pass
159	5795	16.31	16.33	16.62	16.60	16.32	16.7	16.89	17.03	366.298	25.64	25.73	Pass

Note: 1. Directional gain is 10.27dB > 6dBi, so the power limit shall be reduced to $30-(10.27-6) = 25.73$ dBm.

802.11ax (HE80)

Chan.	Freq. (MHz)	Maximum Conducted Power (dBm)								Total Power (mW)	Total Power (dBm)	Limit (dBm)	Pass / Fail
		Chain 0	Chain 1	Chain 2	Chain 3	Chain 4	Chain 5	Chain 6	Chain 7				
155	5775	16.34	16.50	16.73	16.49	16.51	16.6	17	16.68	366.542	25.64	25.73	Pass

Note: 1. Directional gain is 10.27dB > 6dBi, so the power limit shall be reduced to $30-(10.27-6) = 25.73$ dBm.

802.11ax (HE80+80)

Chan.	Freq. (MHz)	Maximum Conducted Power (dBm)								Total Power (mW)	Total Power (dBm)	Limit (dBm)	Pass / Fail
		Chain 0	Chain 1	Chain 2	Chain 3	Chain 4	Chain 5	Chain 6	Chain 7				
42+155	5210	Test results refer to U_NII-1 data											
	5775	-	-	-	-	19.22	19.68	19.56	19.91	364.771	25.62	25.73	Pass

Note: 1. Directional gain is 10.27dB > 6dBi, so the power limit shall be reduced to $30-(10.27-6) = 25.73$ dBm.

Beamforming Mode

802.11ac (VHT20)

Chan.	Freq. (MHz)	Maximum Conducted Power (dBm)								Total Power (mW)	Total Power (dBm)	Limit (dBm)	Pass / Fail
		Chain 0	Chain 1	Chain 2	Chain 3	Chain 4	Chain 5	Chain 6	Chain 7				
149	5745	15.91	16.03	16.83	16.81	16.33	16.75	16.71	16.92	361.603	25.58	25.73	Pass
157	5785	16.06	16.14	16.89	16.82	16.45	16.81	16.7	16.89	366.198	25.64	25.73	Pass
165	5825	16.05	16.12	16.86	16.78	16.41	16.75	16.76	16.98	365.75	25.63	25.73	Pass

Note: 1. Directional gain is 10.27dB > 6dBi, so the power limit shall be reduced to $30-(10.27-6) = 25.73$ dBm.

802.11ac (VHT40)

Chan.	Freq. (MHz)	Maximum Conducted Power (dBm)								Total Power (mW)	Total Power (dBm)	Limit (dBm)	Pass / Fail
		Chain 0	Chain 1	Chain 2	Chain 3	Chain 4	Chain 5	Chain 6	Chain 7				
151	5755	16.30	16.05	16.75	16.53	16.45	16.79	16.42	17.02	361.336	25.58	25.73	Pass
159	5795	16.12	16.01	16.66	16.75	16.32	16.96	16.88	16.89	364.621	25.62	25.73	Pass

Note: 1. Directional gain is 10.27dB > 6dBi, so the power limit shall be reduced to $30-(10.27-6) = 25.73$ dBm.

802.11ac (VHT80)

Chan.	Freq. (MHz)	Maximum Conducted Power (dBm)								Total Power (mW)	Total Power (dBm)	Limit (dBm)	Pass / Fail
		Chain 0	Chain 1	Chain 2	Chain 3	Chain 4	Chain 5	Chain 6	Chain 7				
155	5775	16.09	15.97	16.57	16.84	16.31	16.85	16.78	16.97	362.471	25.59	25.73	Pass

Note: 1. Directional gain is 10.27dB > 6dBi, so the power limit shall be reduced to $30-(10.27-6) = 25.73$ dBm.

802.11ac (VHT80+80)

Chan.	Freq. (MHz)	Maximum Conducted Power (dBm)								Total Power (mW)	Total Power (dBm)	Limit (dBm)	Pass / Fail
		Chain 0	Chain 1	Chain 2	Chain 3	Chain 4	Chain 5	Chain 6	Chain 7				
42+155	5210	Test results refer to U_NII-1 data											
	5775	-	-	-	-	18.56	19.75	19.87	19.86	360.064	25.56	25.73	Pass

Note: 1. Directional gain is 10.27dB > 6dBi, so the power limit shall be reduced to $30-(10.27-6) = 25.73$ dBm.

802.11ax (HE20)

Chan.	Freq. (MHz)	Maximum Conducted Power (dBm)								Total Power (mW)	Total Power (dBm)	Limit (dBm)	Pass / Fail
		Chain 0	Chain 1	Chain 2	Chain 3	Chain 4	Chain 5	Chain 6	Chain 7				
149	5745	16.33	16.49	17.02	16.72	16.61	16.48	16.58	16.58	366.134	25.64	25.73	Pass
157	5785	16.22	16.32	16.91	16.54	16.43	16.8	16.8	16.8	366.45	25.64	25.73	Pass
165	5825	16.24	16.40	16.84	16.59	16.37	16.74	16.82	16.82	366.359	25.64	25.73	Pass

Note: 1. Directional gain is 10.27dB > 6dBi, so the power limit shall be reduced to $30-(10.27-6) = 25.73$ dBm.

802.11ax (HE40)

Chan.	Freq. (MHz)	Maximum Conducted Power (dBm)								Total Power (mW)	Total Power (dBm)	Limit (dBm)	Pass / Fail
		Chain 0	Chain 1	Chain 2	Chain 3	Chain 4	Chain 5	Chain 6	Chain 7				
151	5755	16.30	16.37	16.76	16.52	16.43	16.67	16.67	17.07	366.098	25.64	25.73	Pass
159	5795	16.31	16.33	16.62	16.60	16.32	16.7	16.89	17.03	366.298	25.64	25.73	Pass

Note: 1. Directional gain is 10.27dB > 6dBi, so the power limit shall be reduced to $30-(10.27-6) = 25.73$ dBm.

802.11ax (HE80)

Chan.	Freq. (MHz)	Maximum Conducted Power (dBm)								Total Power (mW)	Total Power (dBm)	Limit (dBm)	Pass / Fail
		Chain 0	Chain 1	Chain 2	Chain 3	Chain 4	Chain 5	Chain 6	Chain 7				
155	5775	16.34	16.50	16.73	16.49	16.51	16.6	17	16.68	366.542	25.64	25.73	Pass

Note: 1. Directional gain is 10.27dB > 6dBi, so the power limit shall be reduced to $30-(10.27-6) = 25.73$ dBm.

802.11ax (HE80+80)

Chan.	Freq. (MHz)	Maximum Conducted Power (dBm)								Total Power (mW)	Total Power (dBm)	Limit (dBm)	Pass / Fail
		Chain 0	Chain 1	Chain 2	Chain 3	Chain 4	Chain 5	Chain 6	Chain 7				
42+155	5210	Test results refer to U_NII-1 data											
	5775	-	-	-	-	19.22	19.68	19.56	19.91	364.771	25.62	25.73	Pass

Note: 1. Directional gain is 10.27dB > 6dBi, so the power limit shall be reduced to $30-(10.27-6) = 25.73$ dBm.

Client Mode

Non-Beamforming Mode

802.11a

Chan.	Freq. (MHz)	Maximum Conducted Power (dBm)								Total Power (mW)	Total Power (dBm)	Limit (dBm)	Pass / Fail
		Chain 0	Chain 1	Chain 2	Chain 3	Chain 4	Chain 5	Chain 6	Chain 7				
36	5180	11.58	11.05	11.17	10.76	11.08	11.06	11.32	11.37	104.976	20.21	20.30	Pass
40	5200	11.51	11.08	11.02	10.85	10.96	10.99	11.21	11.22	103.281	20.14	20.30	Pass
48	5240	11.57	10.95	11.21	10.82	11.05	11.08	11.34	11.45	105.228	20.22	20.30	Pass

Note: For U-NII-1: Directional gain is 9.7dBi > 6dBi, so the power limit shall be reduced to 24-(9.7-6) = 20.30dBm.

802.11ac (VHT20)

Chan.	Freq. (MHz)	Maximum Conducted Power (dBm)								Total Power (mW)	Total Power (dBm)	Limit (dBm)	Pass / Fail
		Chain 0	Chain 1	Chain 2	Chain 3	Chain 4	Chain 5	Chain 6	Chain 7				
36	5180	11.46	10.63	11.16	10.57	10.82	11.15	11.92	11.43	104.59	20.19	20.30	Pass
40	5200	11.51	10.66	11.23	10.71	10.76	11.01	11.87	11.35	104.407	20.19	20.30	Pass
48	5240	10.67	10.62	11.09	10.95	11.01	10.9	11.25	11.22	100	20.00	20.30	Pass

Note: For U-NII-1: Directional gain is 9.7dBi > 6dBi, so the power limit shall be reduced to 24-(9.7-6) = 20.30dBm.

802.11ac (VHT40)

Chan.	Freq. (MHz)	Maximum Conducted Power (dBm)								Total Power (mW)	Total Power (dBm)	Limit (dBm)	Pass / Fail
		Chain 0	Chain 1	Chain 2	Chain 3	Chain 4	Chain 5	Chain 6	Chain 7				
38	5190	11.32	10.57	11.31	10.32	10.69	10.97	11.55	11.41	101.589	20.07	20.30	Pass
46	5230	11.29	10.61	11.25	10.36	10.71	11.01	11.4	11.31	100.885	20.04	20.30	Pass

Note: For U-NII-1: Directional gain is 9.7dBi > 6dBi, so the power limit shall be reduced to 24-(9.7-6) = 20.30dBm.

802.11ac (VHT80)

Chan.	Freq. (MHz)	Maximum Conducted Power (dBm)								Total Power (mW)	Total Power (dBm)	Limit (dBm)	Pass / Fail
		Chain 0	Chain 1	Chain 2	Chain 3	Chain 4	Chain 5	Chain 6	Chain 7				
42	5210	11.51	10.69	11.21	11.02	10.83	10.97	11.38	11.05	102.824	20.12	20.30	Pass

Note: For U-NII-1: Directional gain is 9.7dBi > 6dBi, so the power limit shall be reduced to 24-(9.7-6) = 20.30dBm.

802.11ac (VHT80+80)

Chan.	Freq. (MHz)	Maximum Conducted Power (dBm)								Total Power (mW)	Total Power (dBm)	Limit (dBm)	Pass / Fail
		Chain 0	Chain 1	Chain 2	Chain 3	Chain 4	Chain 5	Chain 6	Chain 7				
42+155	5210	13.21	13.61	14.33	15.13	-	-	-	-	103.588	20.15	20.30	Pass
	5775	-	-	-	-	15.16	15.23	15.39	15.54	136.556	21.35	25.73	Pass

- Note: 1. For U-NII-1: Directional gain is 9.7dBi > 6dBi, so the power limit shall be reduced to $24-(9.7-6) = 20.30$ dBm.
 2. For U-NII-3: Directional gain is 10.27dB > 6dBi, so the power limit shall be reduced to $30-(10.27-6) = 25.73$ dBm.

802.11ax (HE20)

Chan.	Freq. (MHz)	Maximum Conducted Power (dBm)								Total Power (mW)	Total Power (dBm)	Limit (dBm)	Pass / Fail
		Chain 0	Chain 1	Chain 2	Chain 3	Chain 4	Chain 5	Chain 6	Chain 7				
36	5180	11.64	11.07	11.70	10.66	11.12	10.96	11.48	11.3	106.78	20.28	20.30	Pass
40	5200	11.47	10.96	11.53	10.67	10.98	10.92	11.37	11.51	105.151	20.22	20.30	Pass
48	5240	11.24	10.55	11.41	10.91	11.02	10.83	11.35	10.75	101.106	20.05	20.30	Pass

Note: For U-NII-1: Directional gain is 9.7dBi > 6dBi, so the power limit shall be reduced to $24-(9.7-6) = 20.30$ dBm.

802.11ax (HE40)

Chan.	Freq. (MHz)	Maximum Conducted Power (dBm)								Total Power (mW)	Total Power (dBm)	Limit (dBm)	Pass / Fail
		Chain 0	Chain 1	Chain 2	Chain 3	Chain 4	Chain 5	Chain 6	Chain 7				
38	5190	11.53	11.06	11.65	10.59	11.1	11.16	11.51	11.41	107.002	20.29	20.30	Pass
46	5230	11.49	11.11	11.70	10.62	11.24	11.11	11.37	11.26	106.622	20.28	20.30	Pass

Note: For U-NII-1: Directional gain is 9.7dBi > 6dBi, so the power limit shall be reduced to $24-(9.7-6) = 20.30$ dBm.

802.11ax (HE80)

Chan.	Freq. (MHz)	Maximum Conducted Power (dBm)								Total Power (mW)	Total Power (dBm)	Limit (dBm)	Pass / Fail
		Chain 0	Chain 1	Chain 2	Chain 3	Chain 4	Chain 5	Chain 6	Chain 7				
42	5210	11.59	10.85	11.61	10.86	10.99	11.12	10.36	11.39	103.399	20.15	20.30	Pass

Note: For U-NII-1: Directional gain is 9.7dBi > 6dBi, so the power limit shall be reduced to $24-(9.7-6) = 20.30$ dBm.

802.11ax (HE80+80)

Chan.	Freq. (MHz)	Maximum Conducted Power (dBm)								Total Power (mW)	Total Power (dBm)	Limit (dBm)	Pass / Fail
		Chain 0	Chain 1	Chain 2	Chain 3	Chain 4	Chain 5	Chain 6	Chain 7				
42+155	5210	13.37	13.93	14.22	15.29	-	-	-	-	106.675	20.28	20.30	Pass
	5775	-	-	-	-	15.11	15.19	15.69	15.41	137.293	21.38	25.73	Pass

- Note:
1. For U-NII-1: Directional gain is 9.7dBi > 6dBi, so the power limit shall be reduced to $24-(9.7-6) = 20.30\text{dBm}$.
 2. For U-NII-3: Directional gain is 10.27dB > 6dBi, so the power limit shall be reduced to $30-(10.27-6) = 25.73\text{dBm}$.

Beamforming Mode

802.11ac (VHT20)

Chan.	Freq. (MHz)	Maximum Conducted Power (dBm)								Total Power (mW)	Total Power (dBm)	Limit (dBm)	Pass / Fail
		Chain 0	Chain 1	Chain 2	Chain 3	Chain 4	Chain 5	Chain 6	Chain 7				
36	5180	11.46	10.63	11.16	10.57	10.82	11.15	11.92	11.43	104.59	20.19	20.30	Pass
40	5200	11.51	10.66	11.23	10.71	10.76	11.01	11.87	11.35	104.407	20.19	20.30	Pass
48	5240	10.67	10.62	11.09	10.95	11.01	10.9	11.25	11.22	100	20.00	20.30	Pass

Note: For U-NII-1: Directional gain is 9.7dBi > 6dBi, so the power limit shall be reduced to $24-(9.7-6) = 20.30$ dBm.

802.11ac (VHT40)

Chan.	Freq. (MHz)	Maximum Conducted Power (dBm)								Total Power (mW)	Total Power (dBm)	Limit (dBm)	Pass / Fail
		Chain 0	Chain 1	Chain 2	Chain 3	Chain 4	Chain 5	Chain 6	Chain 7				
38	5190	11.32	10.57	11.31	10.32	10.69	10.97	11.55	11.41	101.589	20.07	20.30	Pass
46	5230	11.29	10.61	11.25	10.36	10.71	11.01	11.4	11.31	100.885	20.04	20.30	Pass

Note: For U-NII-1: Directional gain is 9.7dBi > 6dBi, so the power limit shall be reduced to $24-(9.7-6) = 20.30$ dBm.

802.11ac (VHT80)

Chan.	Freq. (MHz)	Maximum Conducted Power (dBm)								Total Power (mW)	Total Power (dBm)	Limit (dBm)	Pass / Fail
		Chain 0	Chain 1	Chain 2	Chain 3	Chain 4	Chain 5	Chain 6	Chain 7				
42	5210	11.51	10.69	11.21	11.02	10.83	10.97	11.38	11.05	102.824	20.12	20.30	Pass

Note: For U-NII-1: Directional gain is 9.7dBi > 6dBi, so the power limit shall be reduced to $24-(9.7-6) = 20.30$ dBm.

802.11ac (VHT80+80)

Chan.	Freq. (MHz)	Maximum Conducted Power (dBm)								Total Power (mW)	Total Power (dBm)	Limit (dBm)	Pass / Fail
		Chain 0	Chain 1	Chain 2	Chain 3	Chain 4	Chain 5	Chain 6	Chain 7				
42+155	5210	13.21	13.61	14.33	15.13	-	-	-	-	103.588	20.15	20.30	Pass
	5775	-	-	-	-	15.16	15.23	15.39	15.54	136.556	21.35	25.73	Pass

Note: 1. For U-NII-1: Directional gain is 9.7dBi > 6dBi, so the power limit shall be reduced to $24-(9.7-6) = 20.30$ dBm.

2. For U-NII-3: Directional gain is 10.27dB > 6dBi, so the power limit shall be reduced to $30-(10.27-6) = 25.73$ dBm.

802.11ax (HE20)

Chan.	Freq. (MHz)	Maximum Conducted Power (dBm)								Total Power (mW)	Total Power (dBm)	Limit (dBm)	Pass / Fail
		Chain 0	Chain 1	Chain 2	Chain 3	Chain 4	Chain 5	Chain 6	Chain 7				
36	5180	11.64	11.07	11.70	10.66	11.12	10.96	11.48	11.3	106.78	20.28	20.30	Pass
40	5200	11.47	10.96	11.53	10.67	10.98	10.92	11.37	11.51	105.151	20.22	20.30	Pass
48	5240	11.24	10.55	11.41	10.91	11.02	10.83	11.35	10.75	101.106	20.05	20.30	Pass

Note: For U-NII-1: Directional gain is 9.7dBi > 6dBi, so the power limit shall be reduced to $24-(9.7-6) = 20.30$ dBm.

802.11ax (HE40)

Chan.	Freq. (MHz)	Maximum Conducted Power (dBm)								Total Power (mW)	Total Power (dBm)	Limit (dBm)	Pass / Fail
		Chain 0	Chain 1	Chain 2	Chain 3	Chain 4	Chain 5	Chain 6	Chain 7				
38	5190	11.53	11.06	11.65	10.59	11.1	11.16	11.51	11.41	107.002	20.29	20.30	Pass
46	5230	11.49	11.11	11.70	10.62	11.24	11.11	11.37	11.26	106.622	20.28	20.30	Pass

Note: For U-NII-1: Directional gain is 9.7dBi > 6dBi, so the power limit shall be reduced to $24-(9.7-6) = 20.30$ dBm.

802.11ax (HE80)

Chan.	Freq. (MHz)	Maximum Conducted Power (dBm)								Total Power (mW)	Total Power (dBm)	Limit (dBm)	Pass / Fail
		Chain 0	Chain 1	Chain 2	Chain 3	Chain 4	Chain 5	Chain 6	Chain 7				
42	5210	11.59	10.85	11.61	10.86	10.99	11.12	10.36	11.39	103.399	20.15	20.30	Pass

Note: For U-NII-1: Directional gain is 9.7dBi > 6dBi, so the power limit shall be reduced to $24-(9.7-6) = 20.30$ dBm.

802.11ax (HE80+80)

Chan.	Freq. (MHz)	Maximum Conducted Power (dBm)								Total Power (mW)	Total Power (dBm)	Limit (dBm)	Pass / Fail
		Chain 0	Chain 1	Chain 2	Chain 3	Chain 4	Chain 5	Chain 6	Chain 7				
42+155	5210	13.37	13.93	14.22	15.29	-	-	-	-	106.675	20.28	20.30	Pass
	5775	-	-	-	-	15.11	15.19	15.69	15.41	137.293	21.38	25.73	Pass

Note: 1. For U-NII-1: Directional gain is 9.7dBi > 6dBi, so the power limit shall be reduced to $24-(9.7-6) = 20.30$ dBm.

2. For U-NII-3: Directional gain is 10.27dB > 6dBi, so the power limit shall be reduced to $30-(10.27-6) = 25.73$ dBm.

4.4 Occupied Bandwidth Measurement

4.4.1 Test Setup

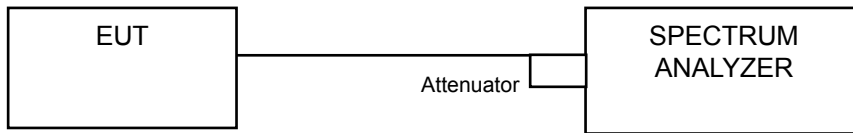

4.4.2 Test Instruments

Refer to section 4.1.2 to get information of above instrument.

4.4.3 Test Procedure

The transmitter output was connected to the spectrum analyzer through an attenuator. The bandwidth of the fundamental frequency was measured by spectrum analyzer with resolution bandwidth in the range of 1% to 5% of the anticipated emission bandwidth, and a video bandwidth at least 3x the resolution bandwidth and set the detector to SAMPLE. The width of a frequency band such that, below the lower and above the upper frequency limits, the mean powers emitted are each equal to a specified percentage 0.5 %of the total mean power of a given emission.

4.4.4 Test Results

Non-Beamforming Mode

802.11a

Channel	Channel Frequency (MHz)	Occupied Bandwidth (MHz)							
		Chain 0	Chain 1	Chain 2	Chain 3	Chain 4	Chain 5	Chain 6	Chain 7
36	5180	16.68	16.68	16.80	16.68	16.68	16.80	16.80	16.68
40	5200	16.80	16.80	16.68	16.80	16.68	16.92	16.80	16.68
48	5240	17.04	16.80	16.80	16.68	16.80	16.92	16.80	16.68
149	5745	16.92	16.80	16.68	16.56	16.68	16.68	16.80	16.68
157	5785	17.04	16.68	16.80	16.56	16.68	16.92	16.68	16.56
165	5825	16.92	16.68	16.80	16.80	16.68	16.80	16.92	16.68

802.11ax (HE20)

Channel	Channel Frequency (MHz)	Occupied Bandwidth (MHz)							
		Chain 0	Chain 1	Chain 2	Chain 3	Chain 4	Chain 5	Chain 6	Chain 7
36	5180	18.96	18.96	18.96	18.96	19.20	18.84	18.84	18.96
40	5200	18.84	18.96	19.08	18.96	18.96	19.08	18.96	18.96
48	5240	19.20	18.96	19.08	19.08	18.96	18.84	19.08	18.96
149	5745	18.96	18.96	19.08	18.96	18.84	18.96	19.08	18.96
157	5785	18.84	18.96	18.96	18.96	18.96	18.96	18.96	18.96
165	5825	18.96	18.96	18.96	18.96	18.96	18.96	18.96	18.84

802.11ax (HE40)

Channel	Channel Frequency (MHz)	Occupied Bandwidth (MHz)							
		Chain 0	Chain 1	Chain 2	Chain 3	Chain 4	Chain 5	Chain 6	Chain 7
38	5190	38.16	38.16	38.16	38.16	38.16	37.92	38.16	37.92
46	5230	38.16	38.40	37.92	37.92	38.16	38.16	38.16	38.16
151	5755	38.16	37.92	37.92	38.16	38.16	37.92	37.92	38.16
159	5795	38.40	38.16	37.68	38.40	37.68	38.16	38.16	38.16

802.11ax (HE80)

Channel	Channel Frequency (MHz)	Occupied Bandwidth (MHz)							
		Chain 0	Chain 1	Chain 2	Chain 3	Chain 4	Chain 5	Chain 6	Chain 7
42	5210	77.76	77.28	77.28	77.28	77.76	77.76	77.28	77.28
155	5775	77.28	76.80	77.28	77.28	77.28	76.80	77.28	77.28

802.11ax (HE80+80)

Channel	Channel Frequency (MHz)	Occupied Bandwidth (MHz)							
		Chain 0	Chain 1	Chain 2	Chain 3	Chain 4	Chain 5	Chain 6	Chain 7
42+155	5210	77.76	77.28	77.28	77.28	-	-	-	-
	5775	-	-	-	-	77.28	77.28	77.28	77.28

Spectrum Plot of Worst Value

802.11a_Chain 0 / CH48

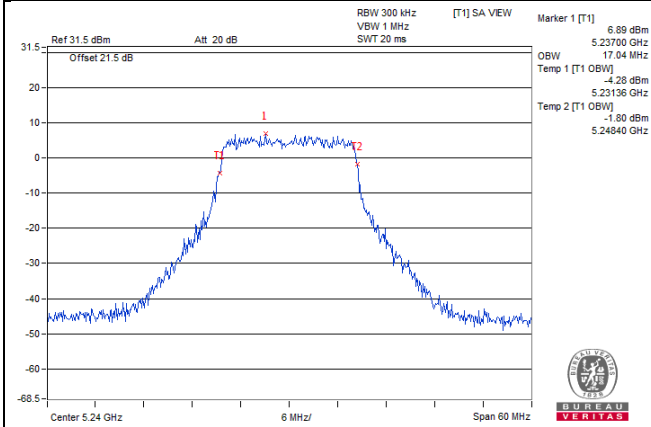

802.11ax (HE20)_Chain 0 / CH48

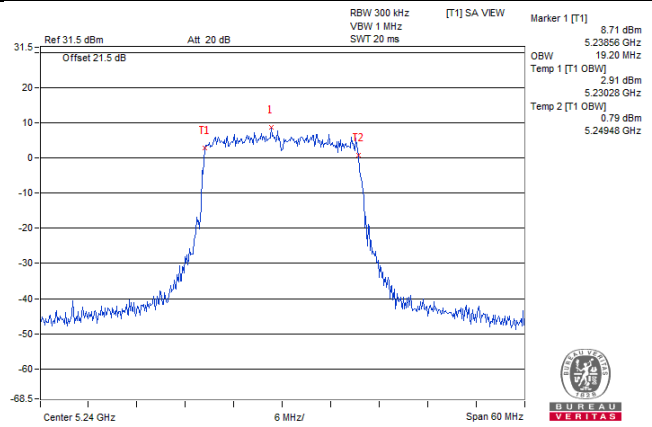

802.11ax (HE40)_Chain 0 / CH159

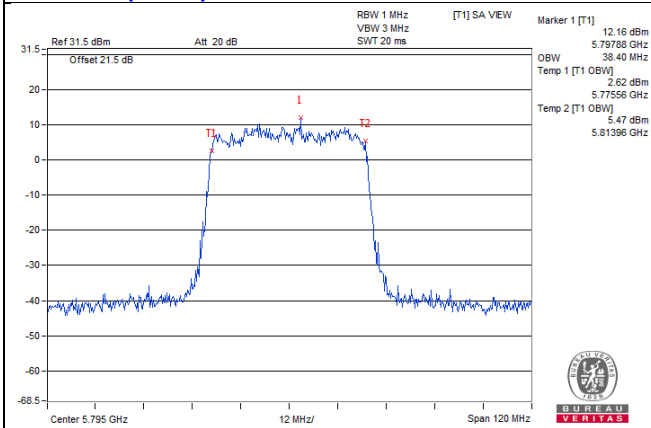

802.11ax (HE80)_Chain 4 / CH42

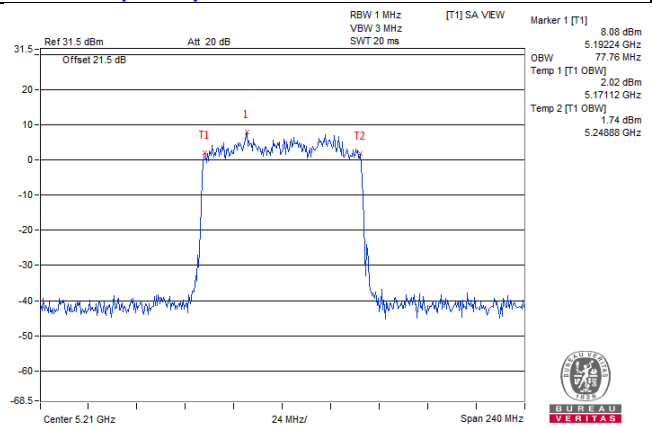

802.11ax (HE80+80)_Chain 0 / CH42

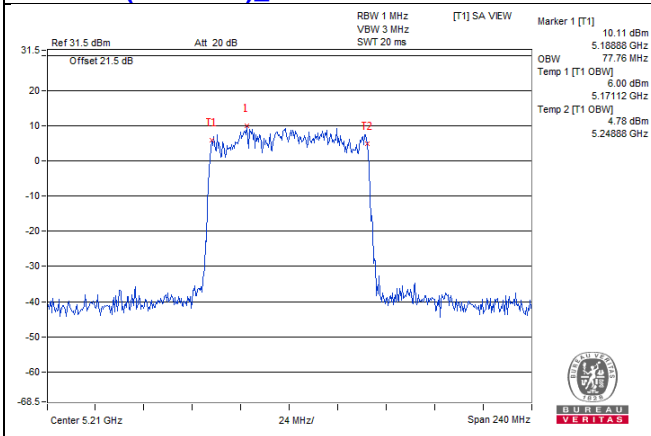

**Spectrum Plot for near by DFS band
(DFS is required, if 99% OCP straddle into U-NII-2A band)**

802.11a_Chain 0 / CH48

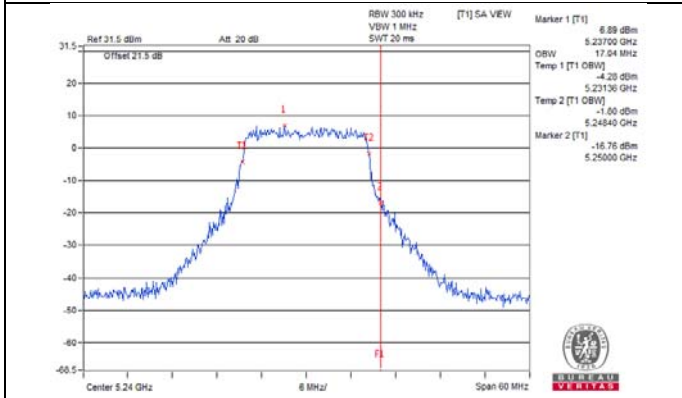

802.11a_Chain 1 / CH48

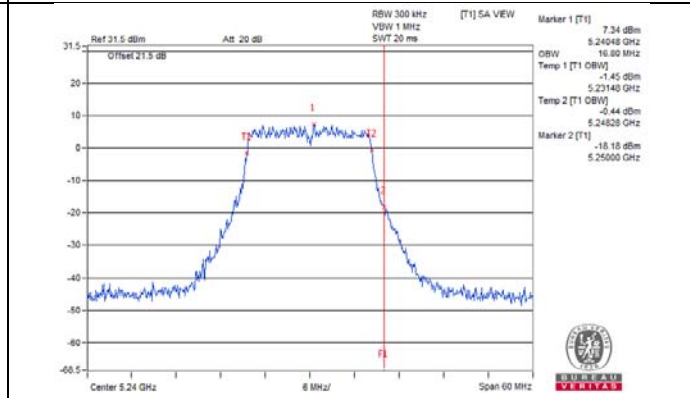

802.11a_Chain 2 / CH48

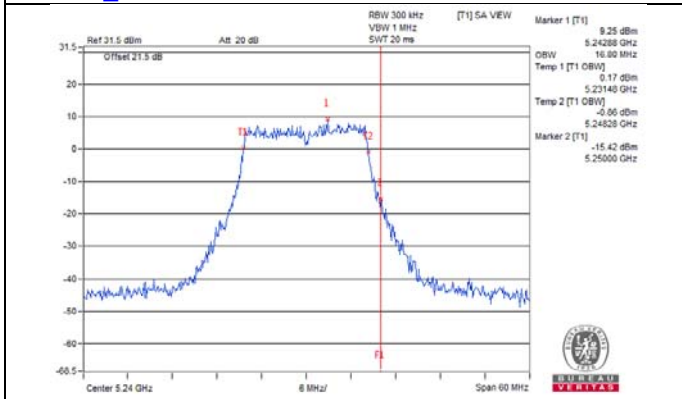

802.11a_Chain 3 / CH48

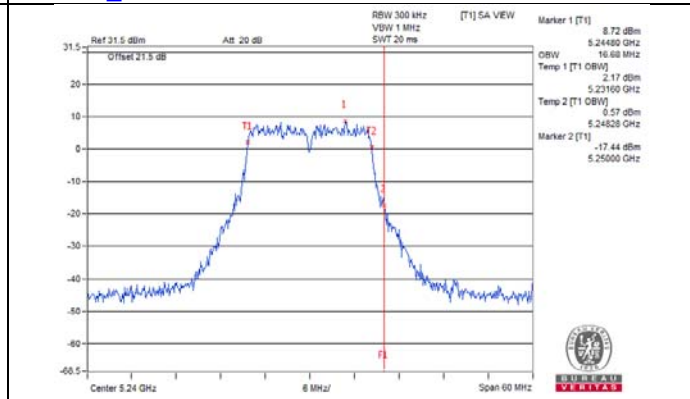

802.11a_Chain 4 / CH48

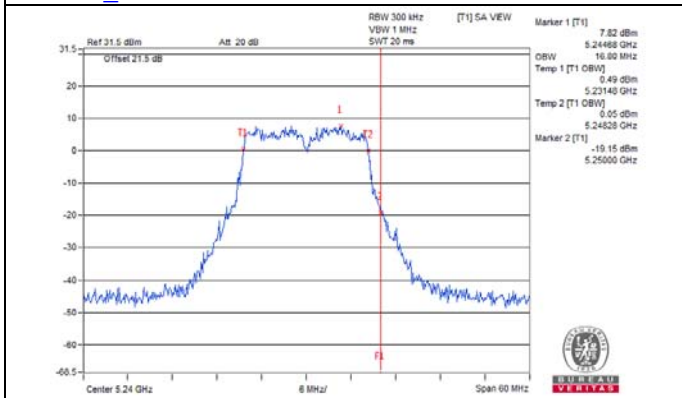

802.11a_Chain 5 / CH48

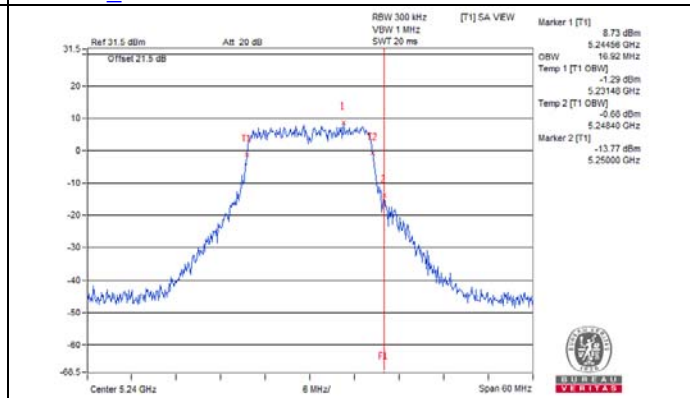

802.11a_Chain 6 / CH48

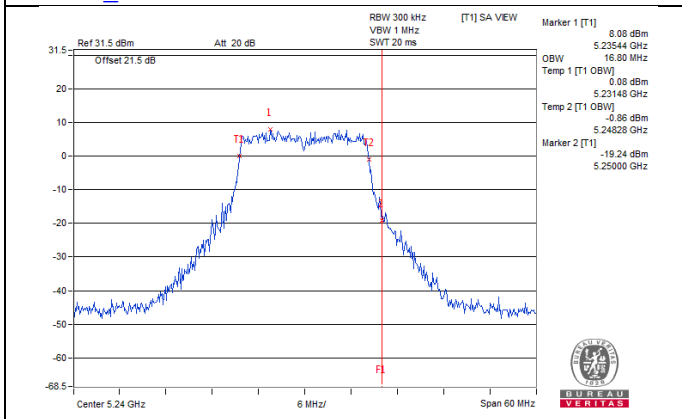

802.11a_Chain 7 / CH48

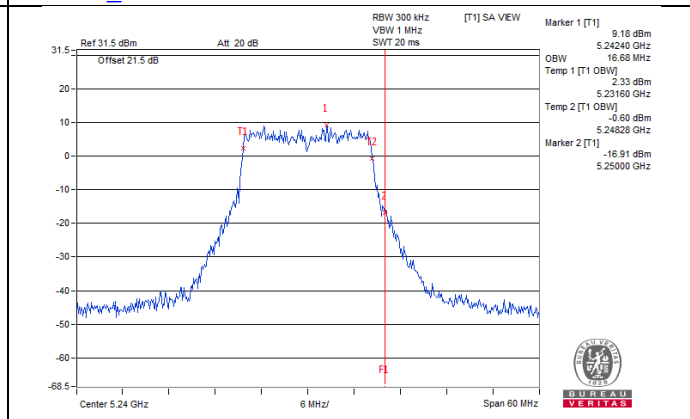

Spectrum Plot for near by DFS band
(DFS is required, if 99% OCP straddle into U-NII-2A band)

802.11ax (HE20)_Chain 0 / CH48

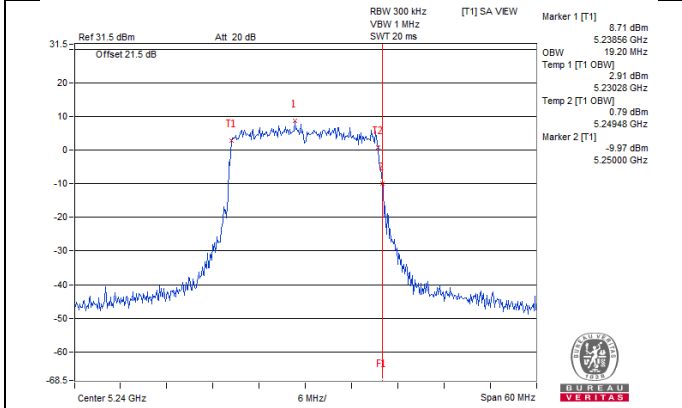

802.11ax (HE20)_Chain 1 / CH48

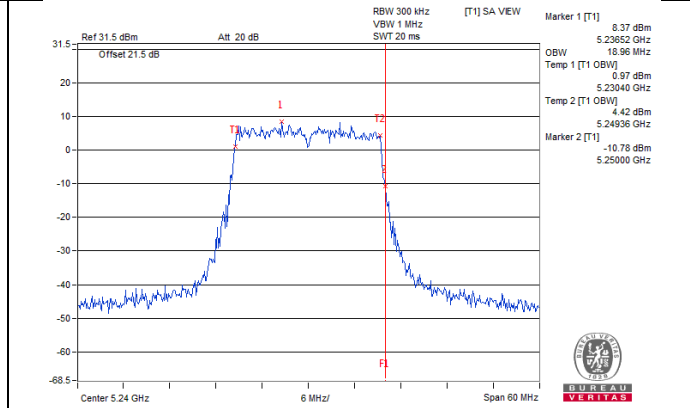

802.11ax (HE20)_Chain 2 / CH48

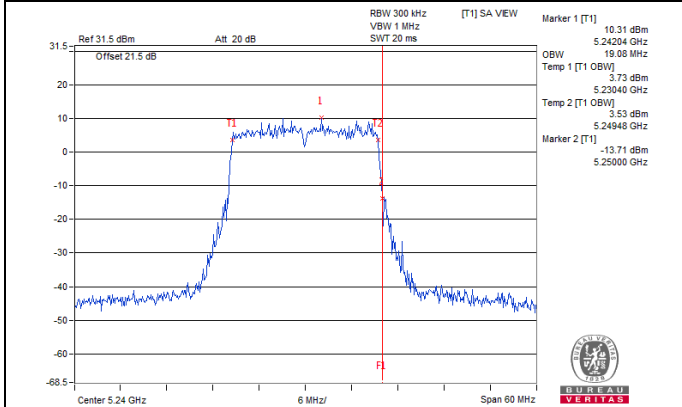

802.11ax (HE20)_Chain 3 / CH48

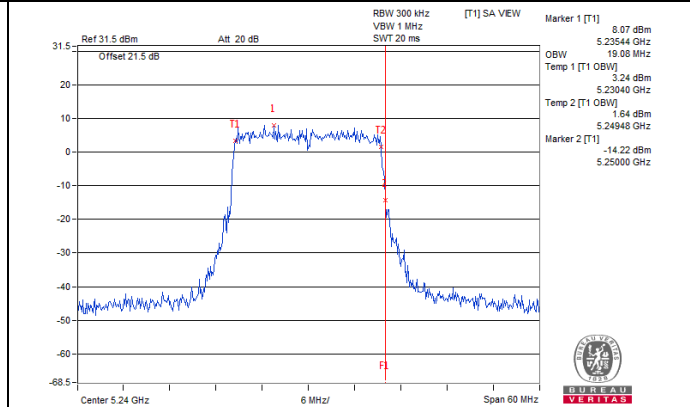

802.11ax (HE20)_Chain 4 / CH48

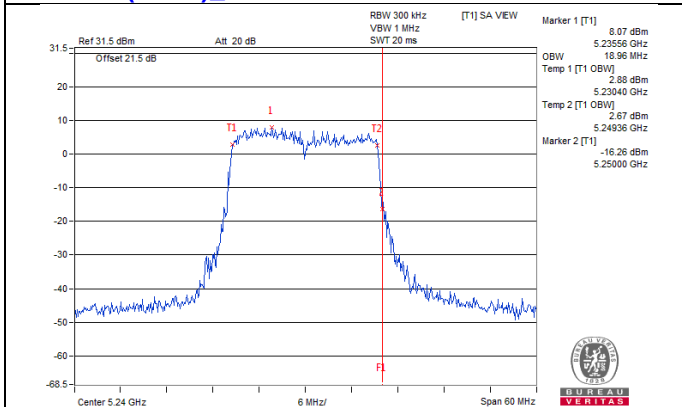

802.11ax (HE20)_Chain 5 / CH48

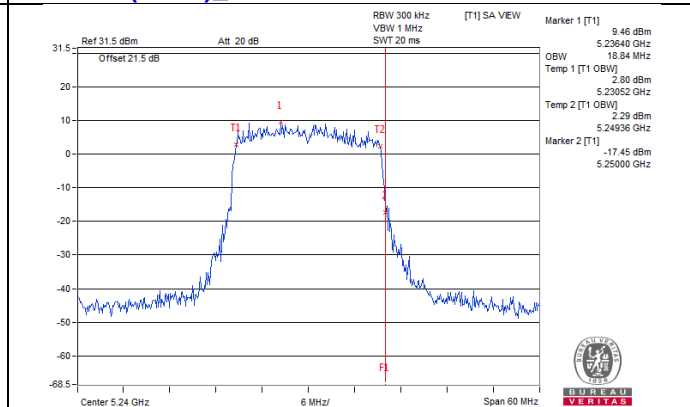

802.11ax (HE20)_Chain 6 / CH48

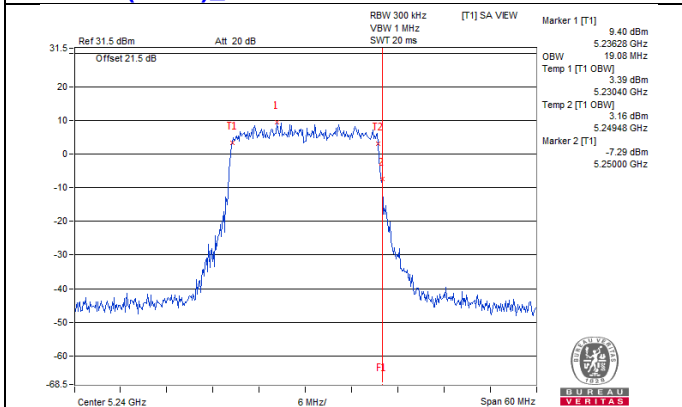

802.11ax (HE20)_Chain 7 / CH48

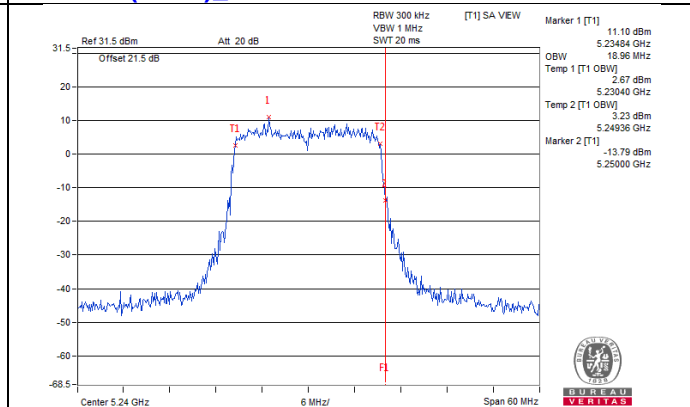

Spectrum Plot for near by DFS band
(DFS is required, if 99% OCP straddle into U-NII-2A band)

802.11ax (HE40)_Chain 0 / CH46

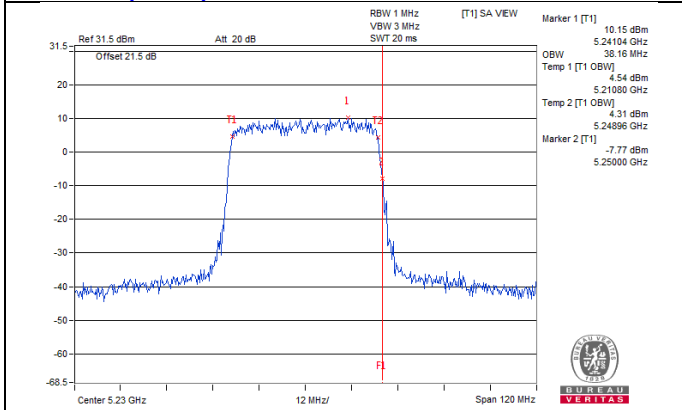

802.11ax (HE40)_Chain 1 / CH46

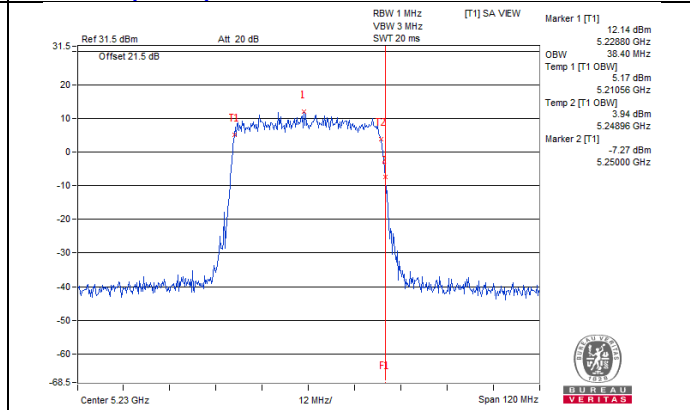

802.11ax (HE40)_Chain 2 / CH46

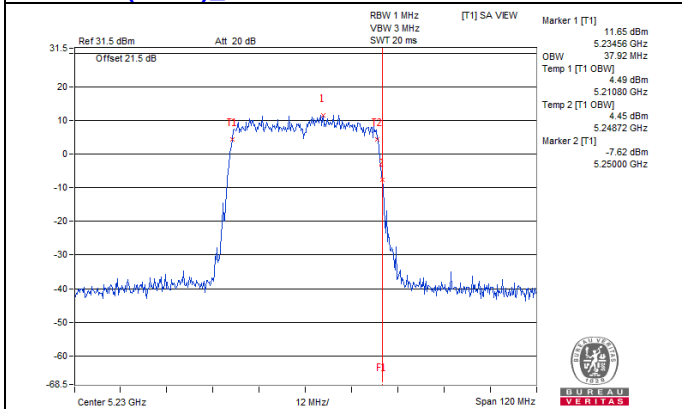

802.11ax (HE40)_Chain 3 / CH46

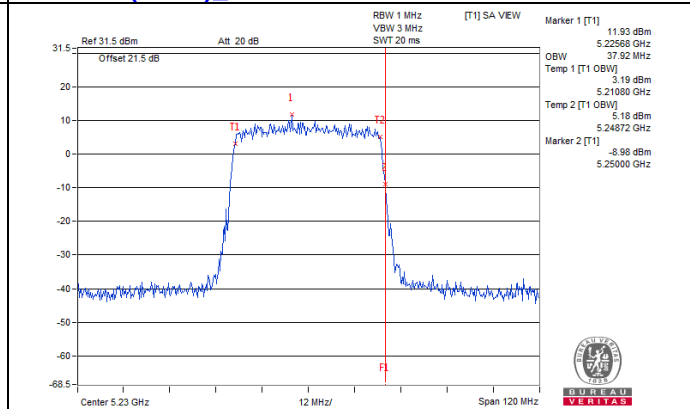

802.11ax (HE40)_Chain 4 / CH46

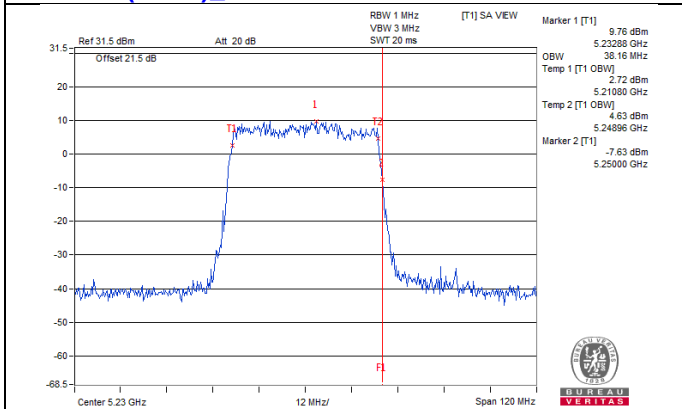

802.11ax (HE40)_Chain 5 / CH46

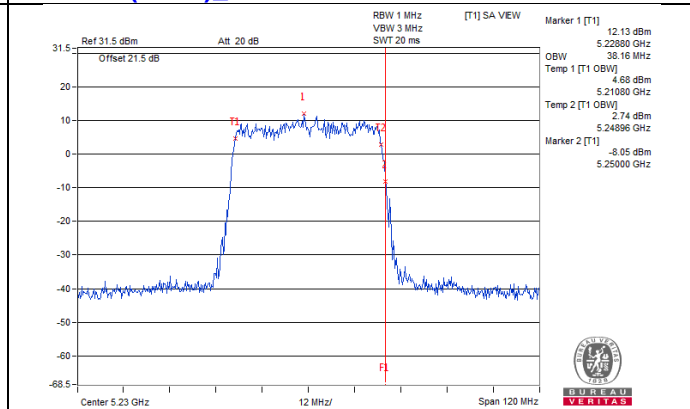

802.11ax (HE40)_Chain 6 / CH46

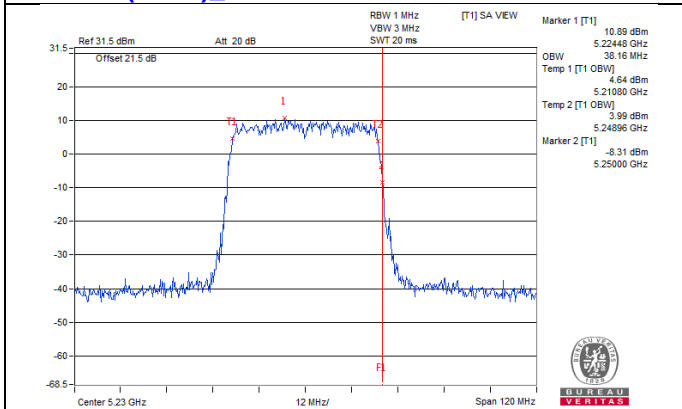

802.11ax (HE40)_Chain 7 / CH46

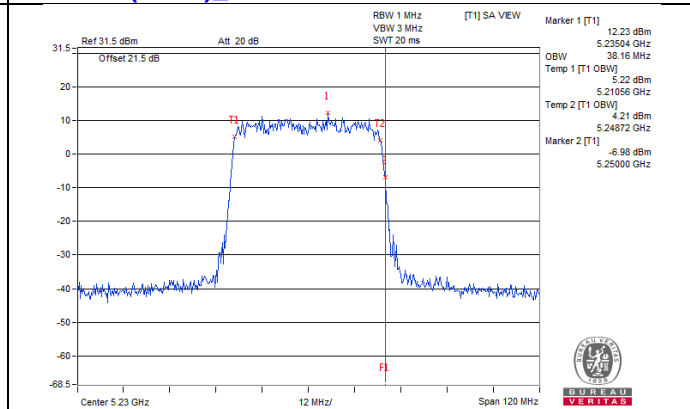

Spectrum Plot for near by DFS band
(DFS is required, if 99% OCP straddle into U-NII-2A band)

802.11ax (HE80)_Chain 0 / CH42

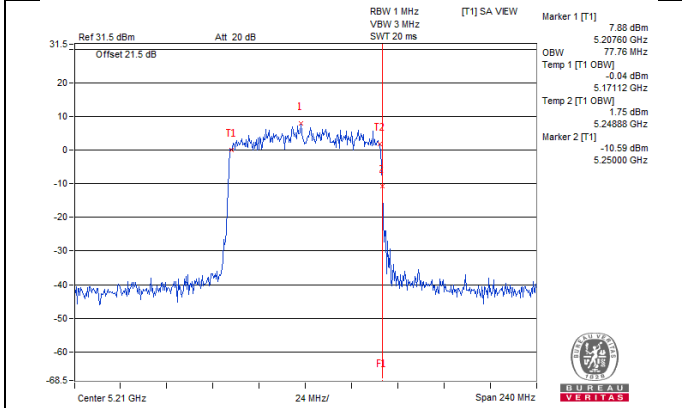

802.11ax (HE80)_Chain 1 / CH42

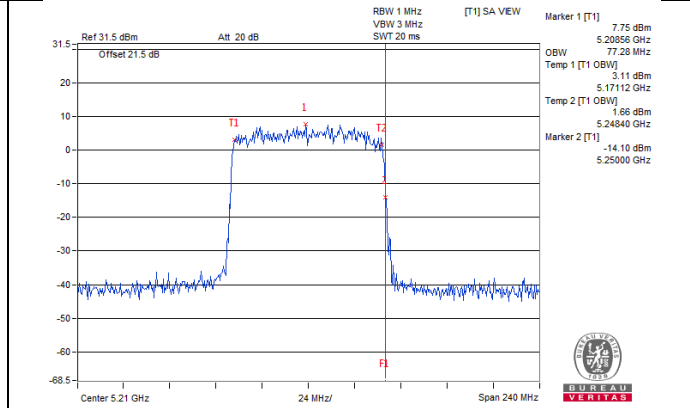

802.11ax (HE80)_Chain 2 / CH42

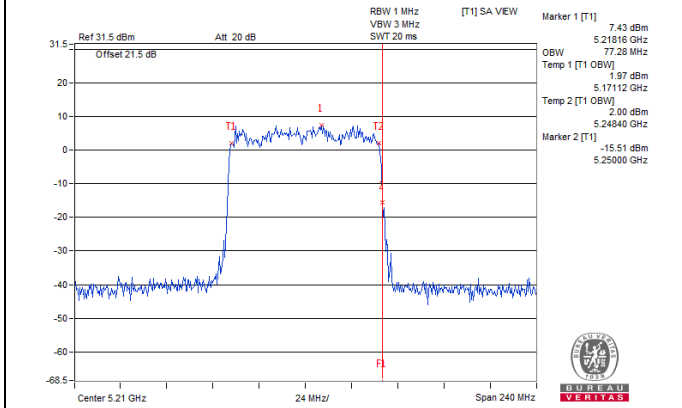

802.11ax (HE80)_Chain 3 / CH42

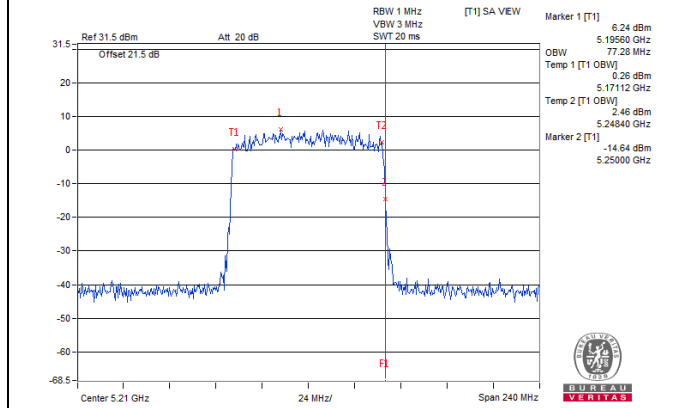

802.11ax (HE80)_Chain 4 / CH42

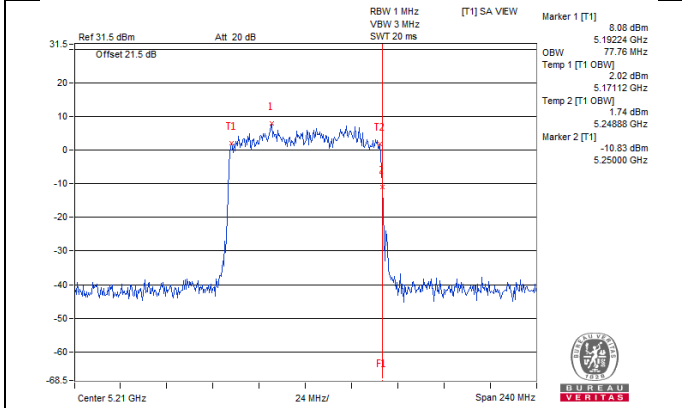

802.11ax (HE80)_Chain 5 / CH42

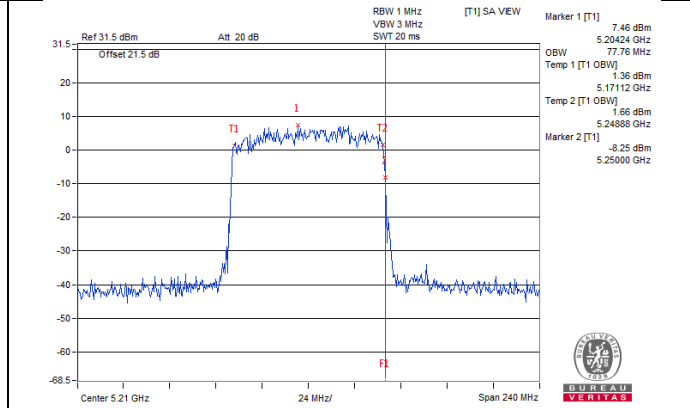

802.11ax (HE80)_Chain 6 / CH42

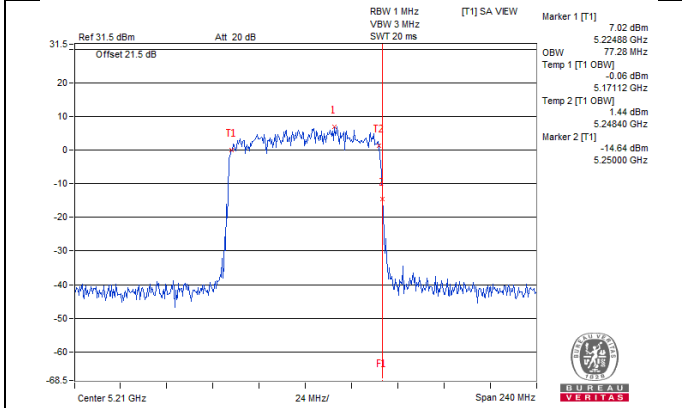

802.11ax (HE80)_Chain 7 / CH42

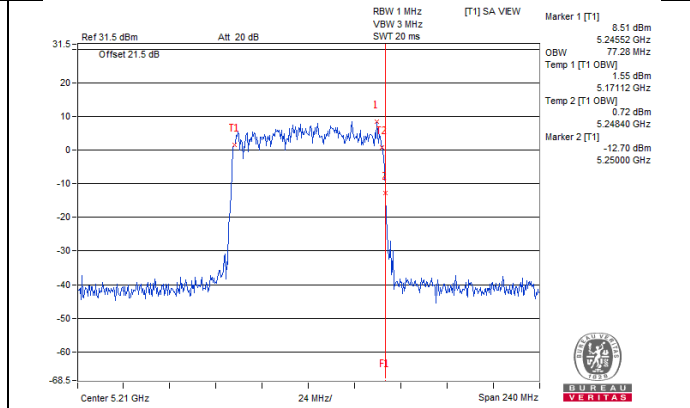

Spectrum Plot for near by DFS band
(DFS is required, if 99% OCP straddle into U-NII-2A band)

802.11ax (HE80+80) / Chain 0 : CH42

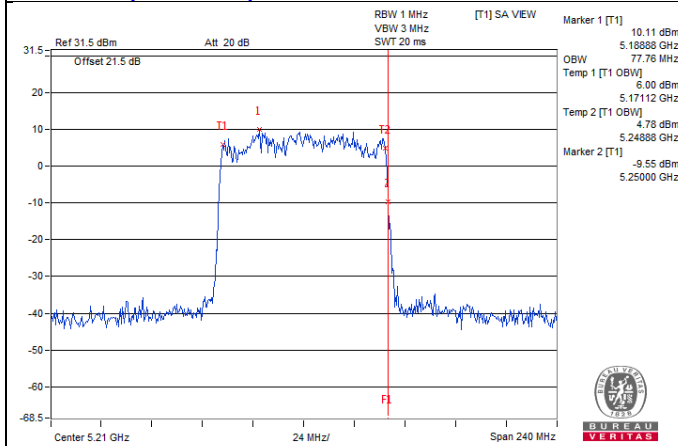

802.11ax (HE80+80) / Chain 1 : CH42

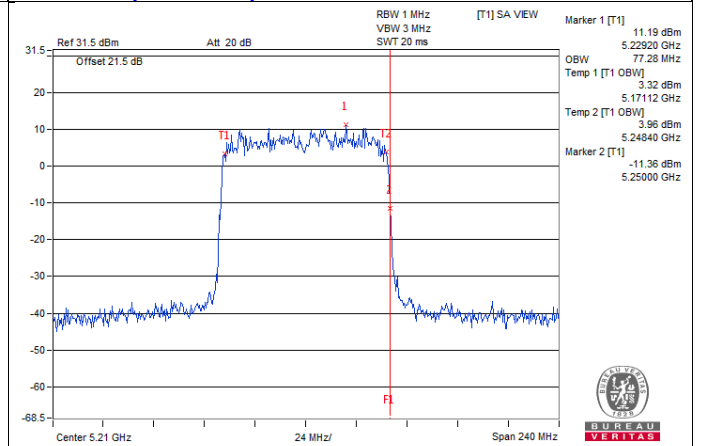

802.11ax (HE80+80) / Chain 2 : CH42

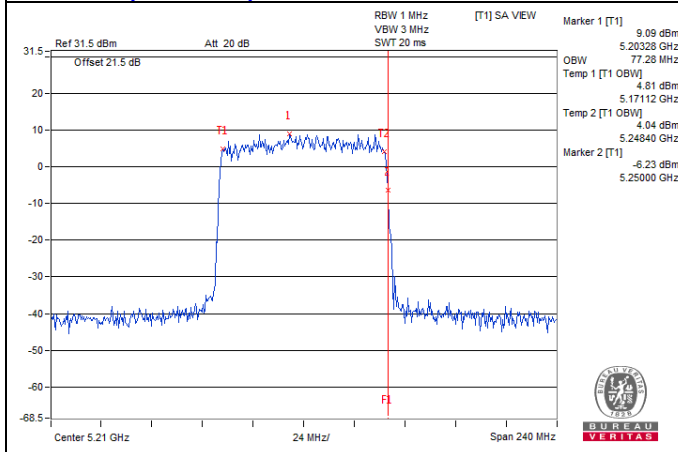

802.11ax (HE80+80) / Chain 3 : CH42

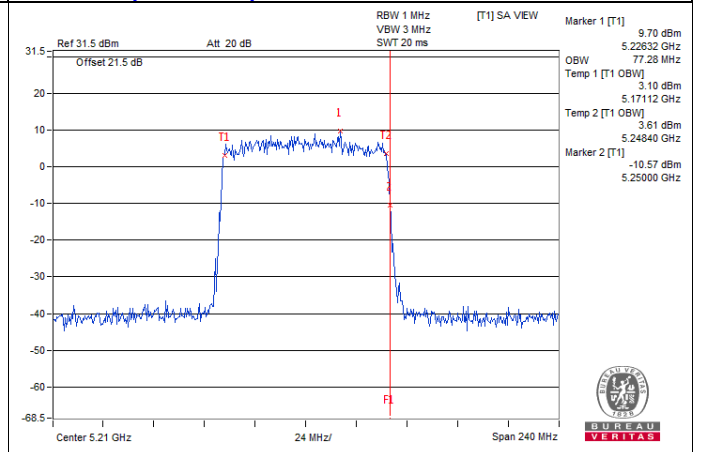

**Spectrum Plot for near by DFS band
(DFS is required, if 99% OCP straddle into U-NII-2C band)**

802.11a_Chain 0 / CH149

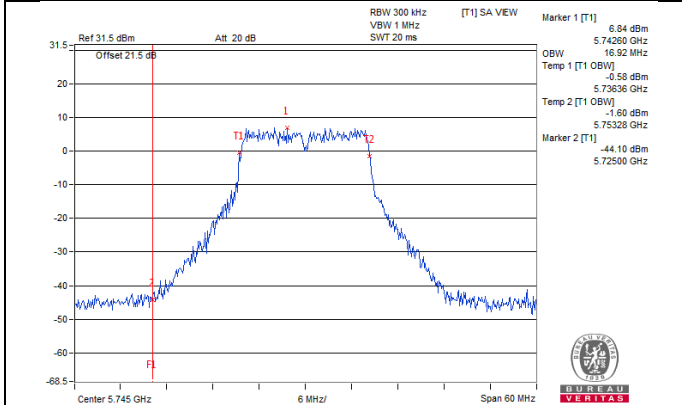

802.11a_Chain 1 / CH149

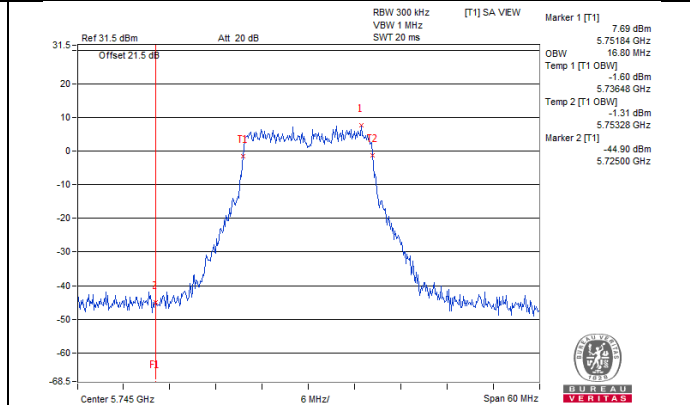

802.11a_Chain 2 / CH149

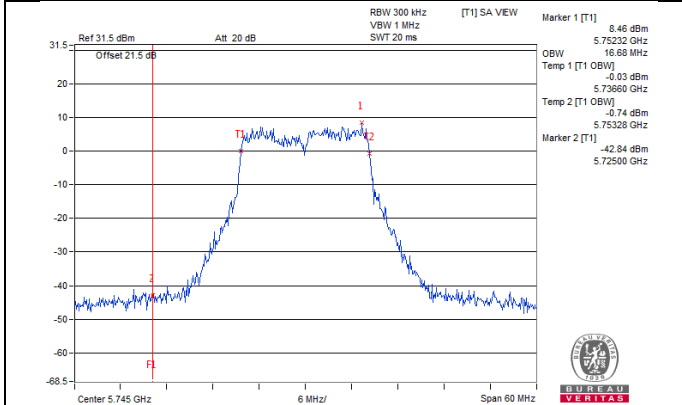

802.11a_Chain 3 / CH149

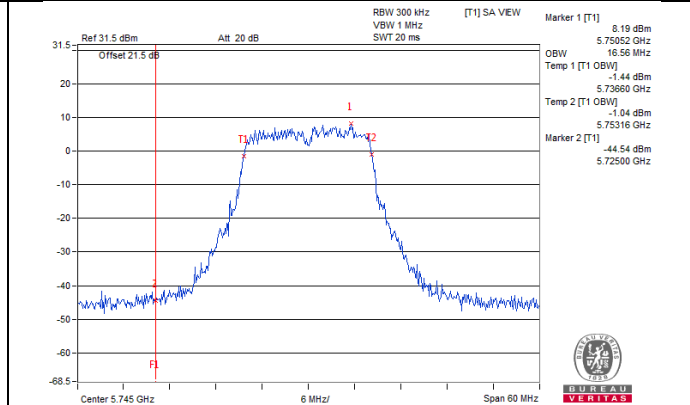

802.11a_Chain 4 / CH149

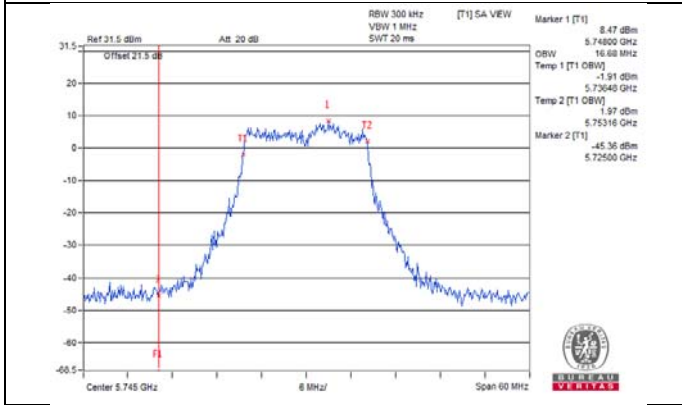

802.11a_Chain 5 / CH149

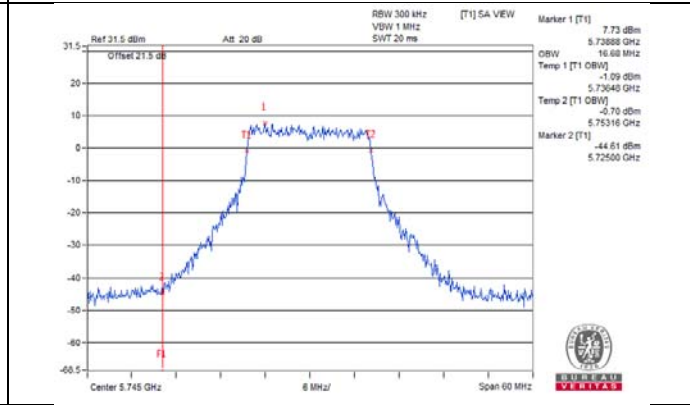

802.11a_Chain 6 / CH149

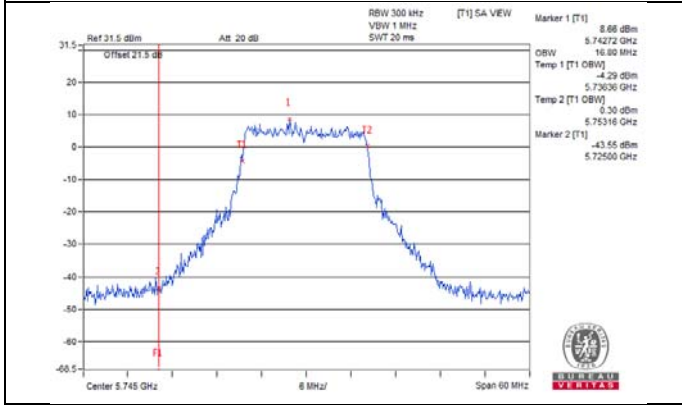

802.11a_Chain 7 / CH149

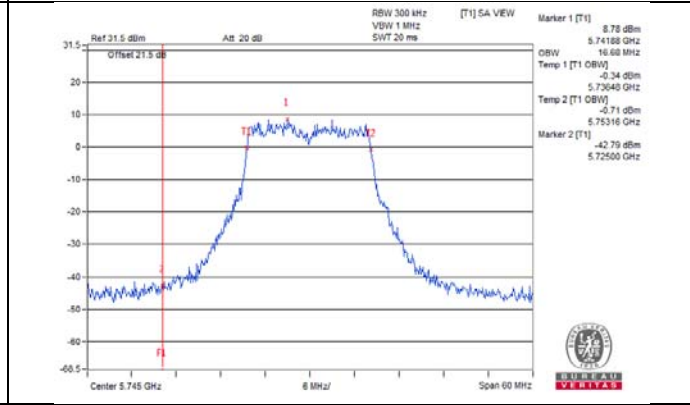

Spectrum Plot for near by DFS band
(DFS is required, if 99% OCP straddle into U-NII-2C band)

802.11ax (HE20)_Chain 0 / CH149

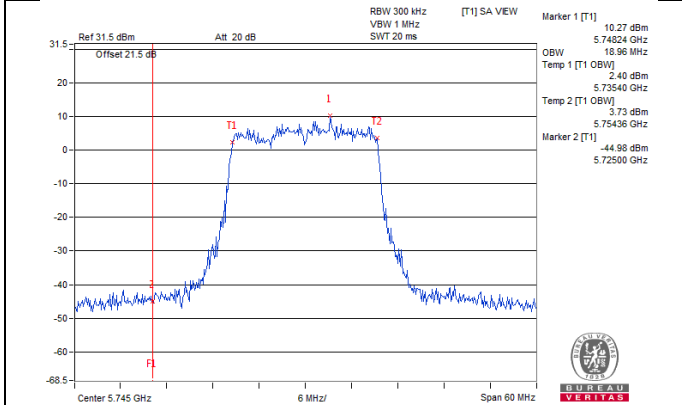

802.11ax (HE20)_Chain 1 / CH149

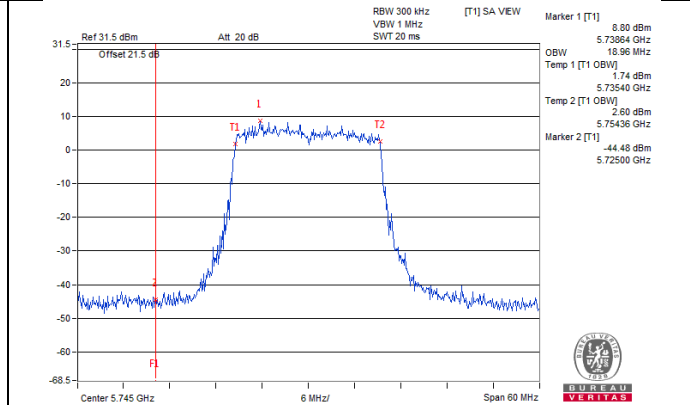

802.11ax (HE20)_Chain 2 / CH149

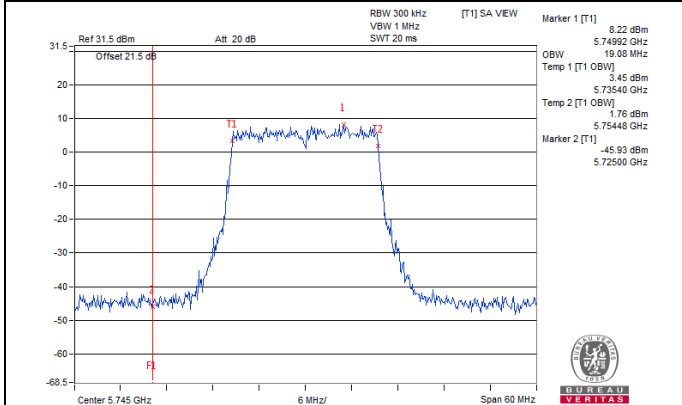

802.11ax (HE20)_Chain 3 / CH149

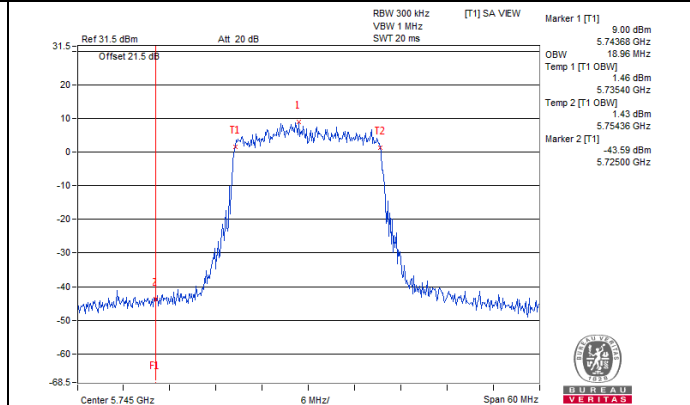

802.11ax (HE20)_Chain 4 / CH149

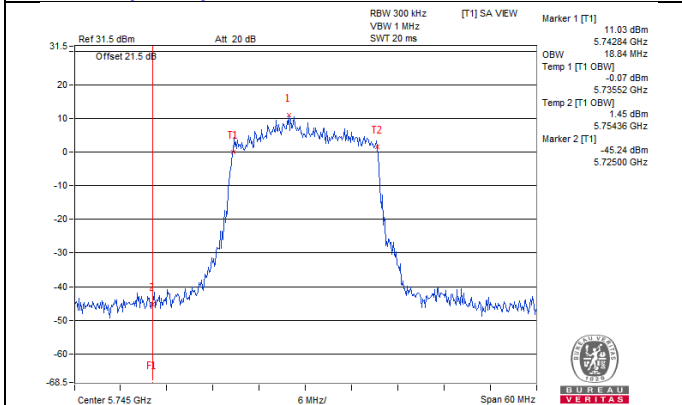

802.11ax (HE20)_Chain 5 / CH149

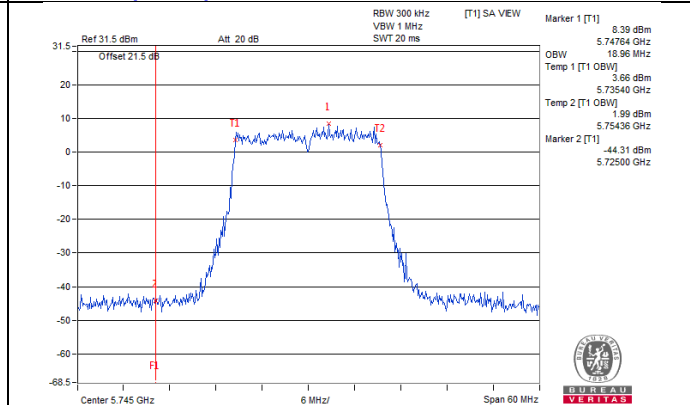

802.11ax (HE20)_Chain 6 / CH149

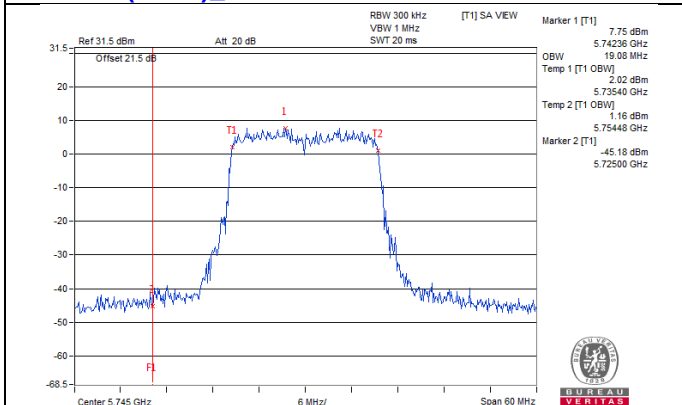

802.11ax (HE20)_Chain 7 / CH149

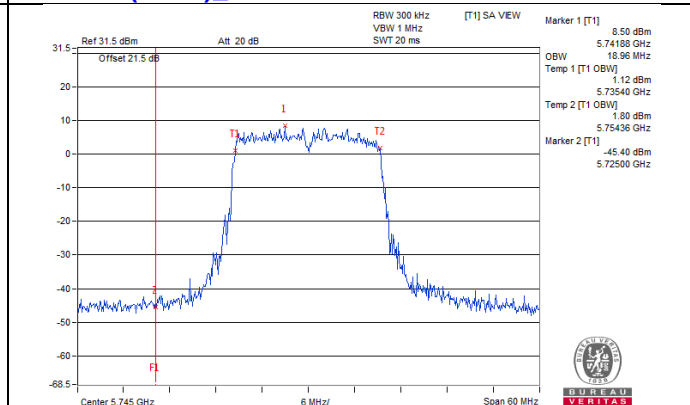

Spectrum Plot for near by DFS band
(DFS is required, if 99% OCP straddle into U-NII-2C band)

802.11ax (HE40)_Chain 0 / CH151

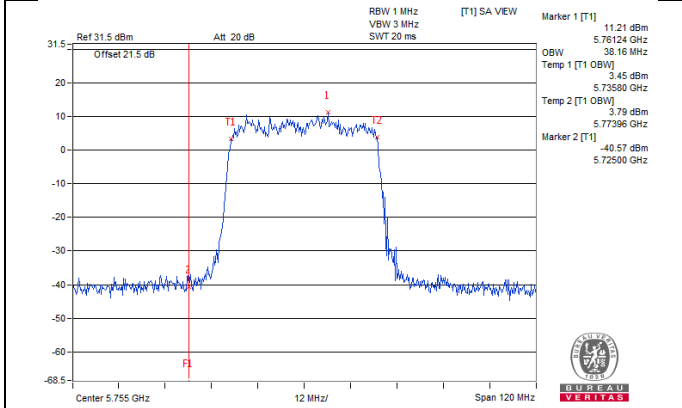

802.11ax (HE40)_Chain 1 / CH151

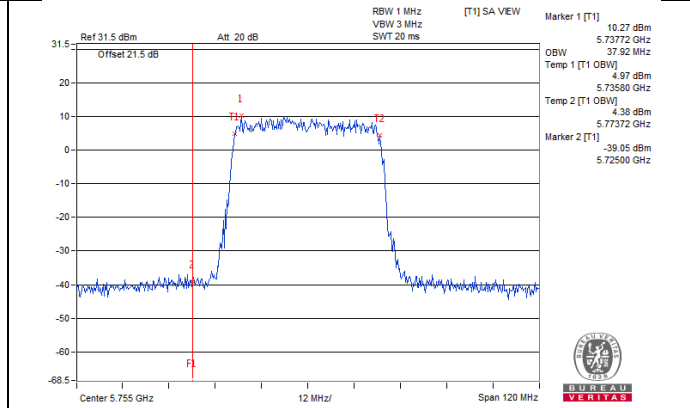

802.11ax (HE40)_Chain 2 / CH151

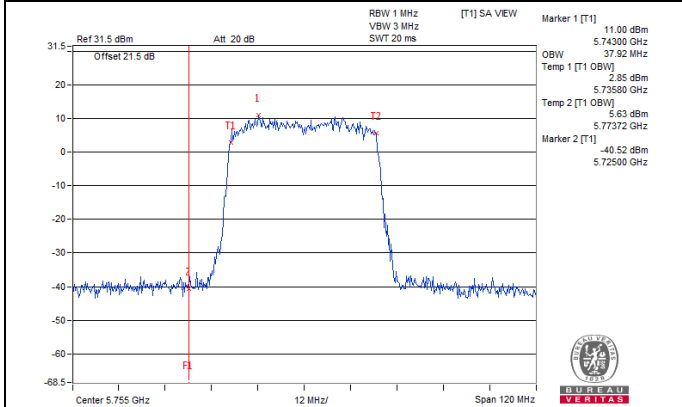

802.11ax (HE40)_Chain 3 / CH151

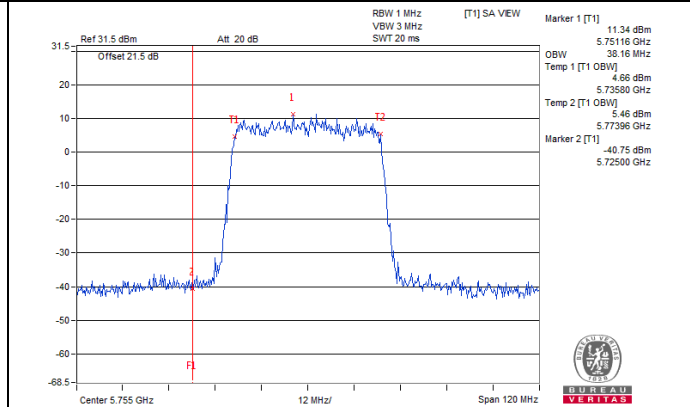

802.11ax (HE40)_Chain 4 / CH151

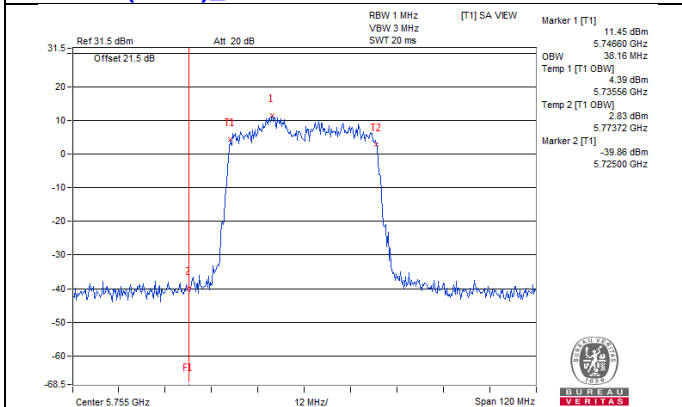

802.11ax (HE40)_Chain 5 / CH151

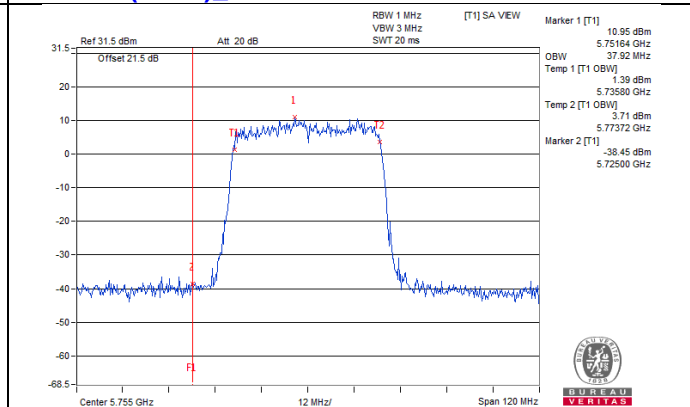

802.11ax (HE40)_Chain 6 / CH151

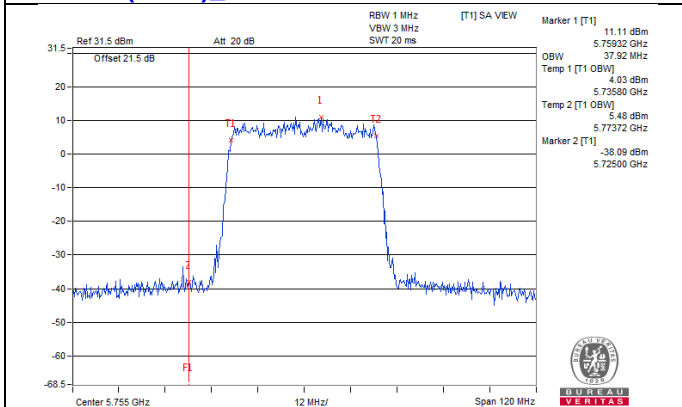

802.11ax (HE40)_Chain 7 / CH151

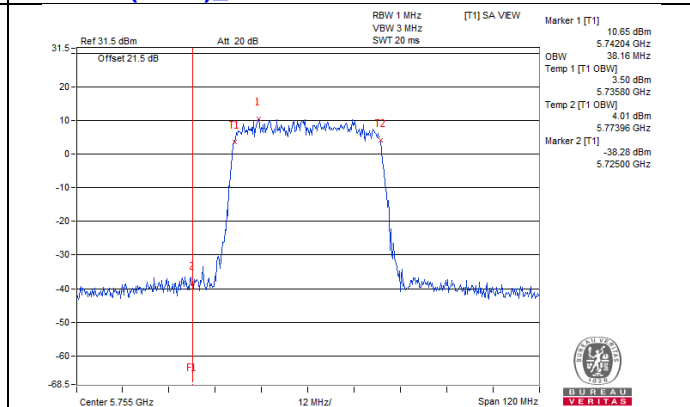

Spectrum Plot for near by DFS band
(DFS is required, if 99% OCP straddle into U-NII-2C band)

802.11ax (HE80)_Chain 0 / CH155

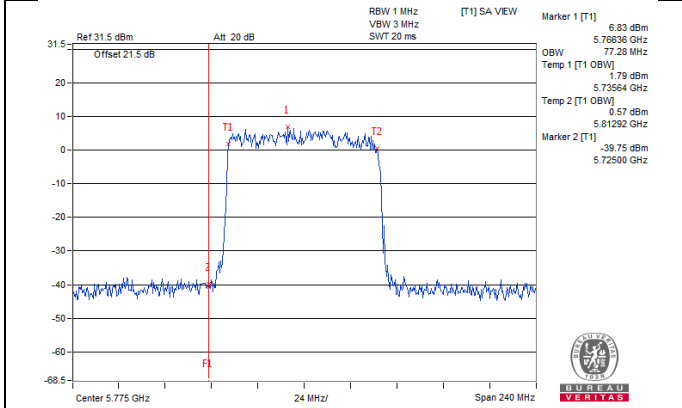

802.11ax (HE80)_Chain 1 / CH155

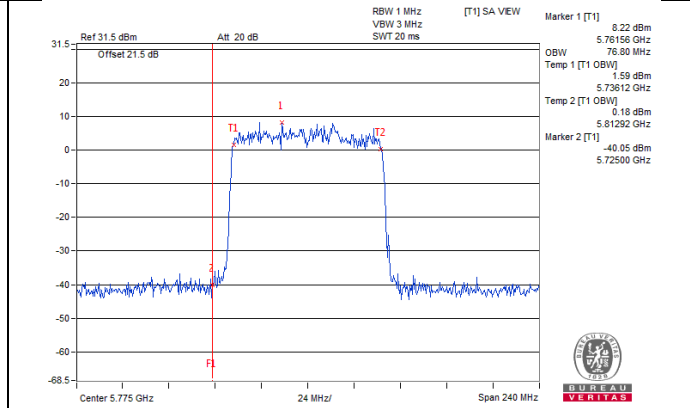

802.11ax (HE80)_Chain 2 / CH155

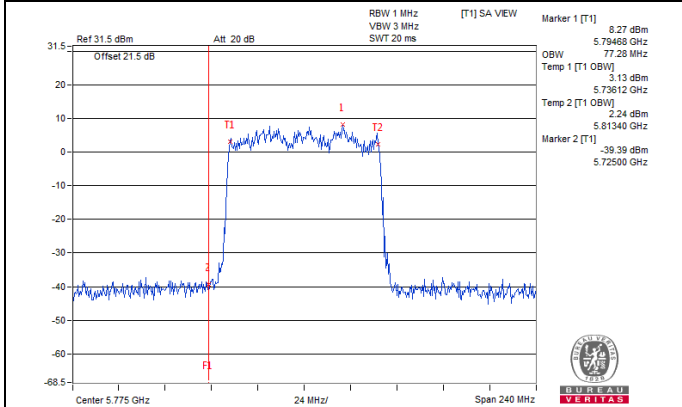

802.11ax (HE80)_Chain 3 / CH155

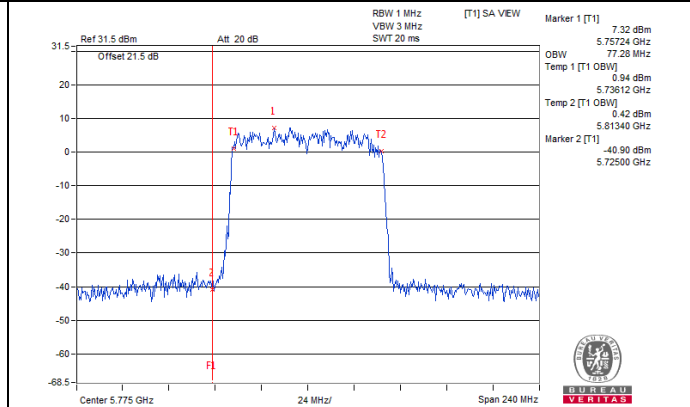

802.11ax (HE80)_Chain 4 / CH155

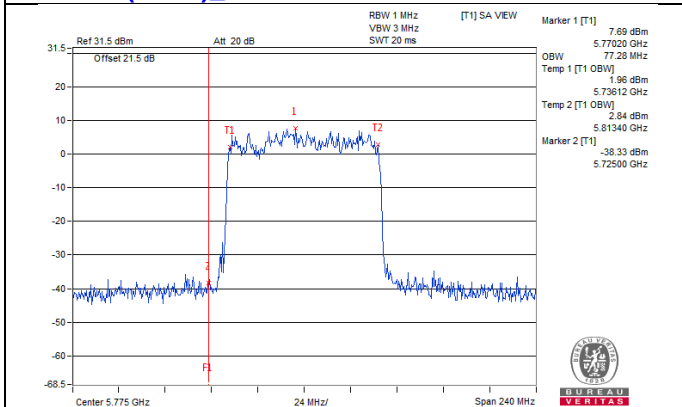

802.11ax (HE80)_Chain 5 / CH155

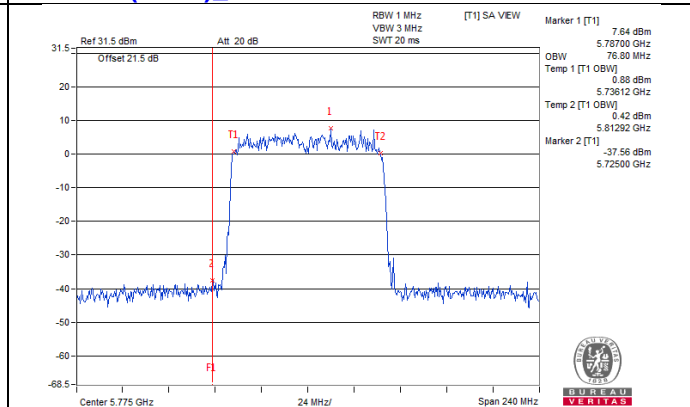

802.11ax (HE80)_Chain 6 / CH155

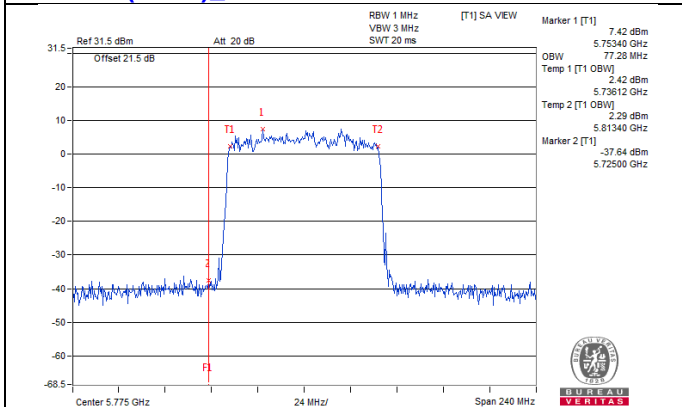

802.11ax (HE80)_Chain 7 / CH155

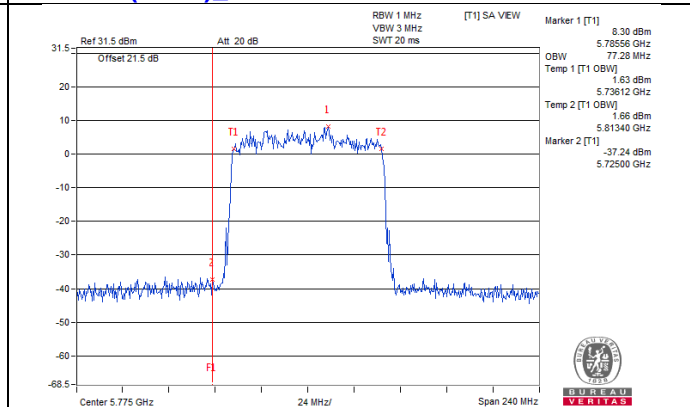

Spectrum Plot for near by DFS band
(DFS is required, if 99% OCP straddle into U-NII-2C band)

802.11ax (HE80+80) / Chain 4 : CH155

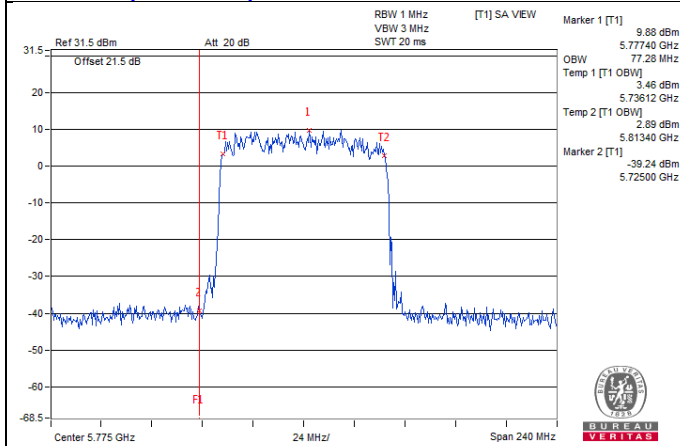

802.11ax (HE80+80) / Chain 5 : CH155

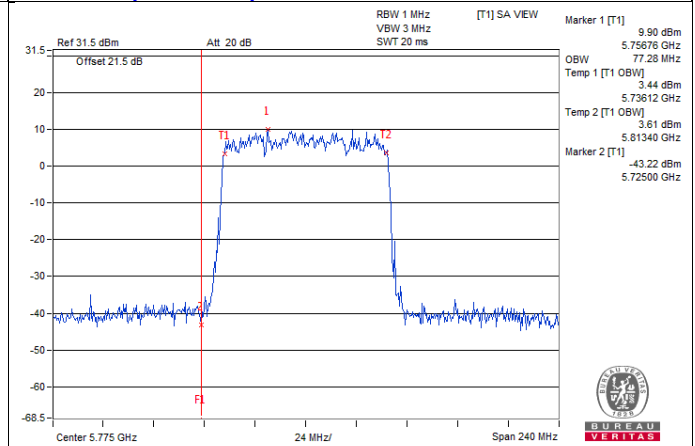

802.11ax (HE80+80) / Chain 6 : CH155

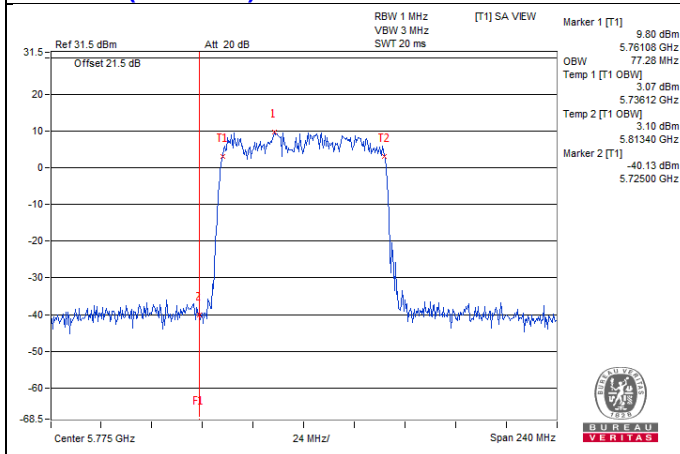

802.11ax (HE80+80) / Chain 7 : CH155

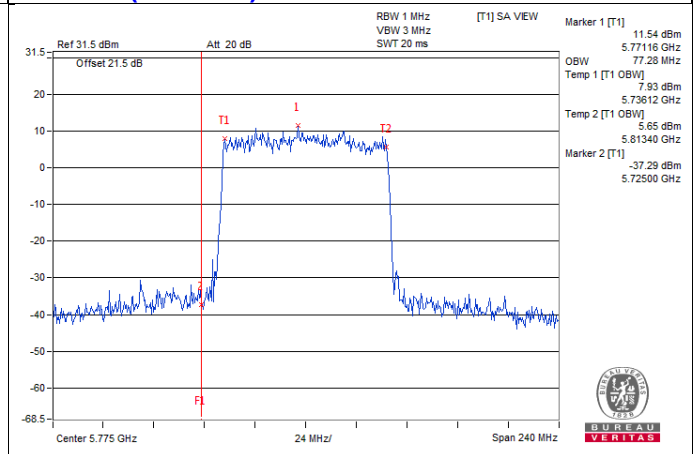

4.5 Peak Power Spectral Density Measurement

4.5.1 Limits of Peak Power Spectral Density Measurement

Operation Band	EUT Category		Limit
U-NII-1		Outdoor Access Point	17dBm/ MHz
		Fixed point-to-point Access Point	
	√	Indoor Access Point	11dBm/ MHz
	√	Client device	
U-NII-2A			11dBm/ MHz
U-NII-2C			11dBm/ MHz
U-NII-3		√	30dBm/ 500kHz

Note: This device can support different category application which switched by access point mode and client mode by software.

4.5.2 Test Setup

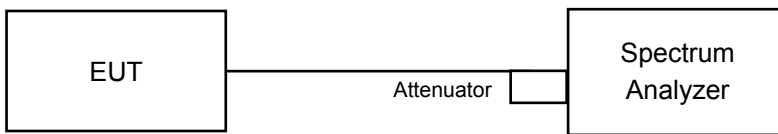

4.5.3 Test Instruments

Refer to section 4.1.2 to get information of above instrument.

4.5.4 Test Procedure

For U-NII-1:

Using method SA-2

1. Set span to encompass the entire emission bandwidth (EBW) of the signal.
2. Set RBW = 1 MHz, Set VBW \geq 3 MHz, Detector = RMS
3. Sweep time = auto, trigger set to "free run".
4. Trace average at least 100 traces in power averaging mode.
5. Record the max value and add $10 \log (1/\text{duty cycle})$

For U-NII-3:

1. Set span to encompass the entire emission bandwidth (EBW) of the signal.
2. Set RBW = 300 kHz, Set VBW \geq 1 MHz, Detector = RMS
3. Use the peak marker function to determine the maximum power level in any 300 kHz band segment within the fundamental EBW.
4. Scale the observed power level to an equivalent value in 500 kHz by adjusting (reducing) the measured power by a bandwidth correction factor (BWCF) where $BWCF = 10 \log(500 \text{ kHz}/300 \text{ kHz})$
5. Sweep time = auto, trigger set to "free run".
6. Trace average at least 100 traces in power averaging mode.
7. Record the max value and add $10 \log (1/\text{duty cycle})$

4.5.5 Deviation from Test Standard

No deviation.

4.5.6 EUT Operating Condition

The software provided by client to enable the EUT under transmission condition continuously at lowest, middle and highest channel frequencies individually.

4.5.7 Test Results
Master Mode
Non-Beamforming Mode
For U-NII-1:
802.11a

Chan.	Freq. (MHz)	PSD W/O Duty Factor (dBm)								Duty Factor (dB)	Total PSD With Duty Factor (dBm)	Max. Limit (dBm/MHz)	Pass / Fail
		Chain 0	Chain 1	Chain 2	Chain 3	Chain 4	Chain 5	Chain 6	Chain 7				
36	5180	2.08	2.75	2.27	2.89	2.24	3.61	2.69	3.50	0.52	11.82	13.30	Pass
40	5200	1.79	0.84	2.95	3.10	2.02	2.27	2.37	2.82	0.52	11.35	13.30	Pass
48	5240	2.28	1.37	2.23	2.92	1.31	3.00	3.38	3.25	0.52	11.56	13.30	Pass

- Note:** 1. Method a) of power density measurement of KDB 662911 is using for calculating total power density. Total power density is summing entire spectra across corresponding frequency bins on the various outputs by computer.
2. Directional gain = 9.7dBi > 6dBi, so the power density limit shall be reduced to $17-(9.7-6) = 13.30\text{dBm}$.
3. Refer to section 3.3 for duty cycle spectrum plot.

802.11ac (VHT20)

Chan.	Freq. (MHz)	PSD W/O Duty Factor (dBm)								Duty Factor (dB)	Total PSD With Duty Factor (dBm)	Max. Limit (dBm/MHz)	Pass / Fail
		Chain 0	Chain 1	Chain 2	Chain 3	Chain 4	Chain 5	Chain 6	Chain 7				
36	5180	2.25	-0.20	1.21	2.61	1.10	3.37	2.96	2.65	0.17	11.16	13.30	Pass
40	5200	2.38	0.86	1.25	2.67	1.92	2.29	1.42	2.07	0.17	10.93	13.30	Pass
48	5240	3.09	2.51	2.97	2.83	3.46	2.70	2.17	3.36	0.17	11.94	13.30	Pass

- Note:** 1. Method a) of power density measurement of KDB 662911 is using for calculating total power density. Total power density is summing entire spectra across corresponding frequency bins on the various outputs by computer.
2. Directional gain = 9.7dBi > 6dBi, so the power density limit shall be reduced to $17-(9.7-6) = 13.30\text{dBm}$.
3. Refer to section 3.3 for duty cycle spectrum plot.

802.11ac (VHT40)

Chan.	Freq. (MHz)	PSD W/O Duty Factor (dBm)								Duty Factor (dB)	Total PSD With Duty Factor (dBm)	Max. Limit (dBm/MHz)	Pass / Fail
		Chain 0	Chain 1	Chain 2	Chain 3	Chain 4	Chain 5	Chain 6	Chain 7				
38	5190	0.02	-0.81	-0.93	-2.22	-1.64	-0.64	-0.89	0.46	0.16	8.27	13.30	Pass
46	5230	-0.74	-1.01	-0.43	0.53	-0.19	0.76	-0.14	-0.24	0.16	8.88	13.30	Pass

- Note:** 1. Method a) of power density measurement of KDB 662911 is using for calculating total power density. Total power density is summing entire spectra across corresponding frequency bins on the various outputs by computer.
2. Directional gain = 9.7dBi > 6dBi, so the power density limit shall be reduced to $17-(9.7-6) = 13.30\text{dBm}$.
3. Refer to section 3.3 for duty cycle spectrum plot.

802.11ac (VHT80)

Chan.	Freq. (MHz)	PSD W/O Duty Factor (dBm)								Duty Factor (dB)	Total PSD With Duty Factor (dBm)	Max. Limit (dBm/MHz)	Pass / Fail
		Chain 0	Chain 1	Chain 2	Chain 3	Chain 4	Chain 5	Chain 6	Chain 7				
42	5210	-5.62	-4.57	-3.16	-5.32	-4.87	-6.19	-3.62	-3.25	0.16	4.59	13.30	Pass

- Note:**
1. Method a) of power density measurement of KDB 662911 is using for calculating total power density. Total power density is summing entire spectra across corresponding frequency bins on the various outputs by computer.
 2. Directional gain = 9.7dBi > 6dBi, so the power density limit shall be reduced to $17-(9.7-6) = 13.30\text{dBm}$.
 3. Refer to section 3.3 for duty cycle spectrum plot.

802.11ac (VHT80+80)

Chan.	Freq. (MHz)	PSD W/O Duty Factor (dBm)								Duty Factor (dB)	Total PSD With Duty Factor (dBm)	Max. Limit (dBm/MHz)	Pass / Fail
		Chain 0	Chain 1	Chain 2	Chain 3	Chain 4	Chain 5	Chain 6	Chain 7				
42+155	5210	-0.06	-3.14	-0.56	-1.95	-	-	-	-	0.16	4.76	13.30	Pass
	5775	Test results refer to U_NII-3 data											

- Note:**
1. Method a) of power density measurement of KDB 662911 is using for calculating total power density. Total power density is summing entire spectra across corresponding frequency bins on the various outputs by computer.
 2. Directional gain = 9.7dBi > 6dBi, so the power density limit shall be reduced to $17-(9.7-6) = 13.30\text{dBm}$.
 3. Refer to section 3.3 for duty cycle spectrum plot.

802.11ax (HE20)

Chan.	Freq. (MHz)	PSD W/O Duty Factor (dBm)								Duty Factor (dB)	Total PSD With Duty Factor (dBm)	Max. Limit (dBm/MHz)	Pass / Fail
		Chain 0	Chain 1	Chain 2	Chain 3	Chain 4	Chain 5	Chain 6	Chain 7				
36	5180	1.67	1.43	3.02	1.49	2.09	1.44	1.24	2.82	0.16	10.98	13.30	Pass
40	5200	1.15	0.88	2.92	1.75	0.96	2.35	0.95	1.25	0.16	10.62	13.30	Pass
48	5240	2.63	2.78	3.35	2.13	3.21	3.29	3.35	3.84	0.16	12.13	13.30	Pass

- Note:**
- Method a) of power density measurement of KDB 662911 is using for calculating total power density. Total power density is summing entire spectra across corresponding frequency bins on the various outputs by computer.
 - Directional gain = 9.7dBi > 6dBi, so the power density limit shall be reduced to $17-(9.7-6) = 13.30\text{dBm}$.
 - Refer to section 3.3 for duty cycle spectrum plot.

802.11ax (HE40)

Chan.	Freq. (MHz)	PSD W/O Duty Factor (dBm)								Duty Factor (dB)	Total PSD With Duty Factor (dBm)	Max. Limit (dBm/MHz)	Pass / Fail
		Chain 0	Chain 1	Chain 2	Chain 3	Chain 4	Chain 5	Chain 6	Chain 7				
38	5190	-0.49	0.19	-0.02	-3.27	-0.95	-0.49	-1.55	0.51	0.18	8.40	13.30	Pass
46	5230	-0.95	0.84	1.35	-0.93	-0.63	-2.14	0.10	0.23	0.18	8.89	13.30	Pass

- Note:**
- Method a) of power density measurement of KDB 662911 is using for calculating total power density. Total power density is summing entire spectra across corresponding frequency bins on the various outputs by computer.
 - Directional gain = 9.7dBi > 6dBi, so the power density limit shall be reduced to $17-(9.7-6) = 13.30\text{dBm}$.
 - Refer to section 3.3 for duty cycle spectrum plot.

802.11ax (HE80)

Chan.	Freq. (MHz)	PSD W/O Duty Factor (dBm)								Duty Factor (dB)	Total PSD With Duty Factor (dBm)	Max. Limit (dBm/MHz)	Pass / Fail
		Chain 0	Chain 1	Chain 2	Chain 3	Chain 4	Chain 5	Chain 6	Chain 7				
42	5210	-4.71	-4.36	-2.63	-5.07	-3.55	-5.26	-4.68	-2.96	0.16	4.98	13.30	Pass

- Note:**
- Method a) of power density measurement of KDB 662911 is using for calculating total power density. Total power density is summing entire spectra across corresponding frequency bins on the various outputs by computer.
 - Directional gain = 9.7dBi > 6dBi, so the power density limit shall be reduced to $17-(9.7-6) = 13.30\text{dBm}$.
 - Refer to section 3.3 for duty cycle spectrum plot.

802.11ax (HE80+80)

Chan.	Freq. (MHz)	PSD W/O Duty Factor (dBm)								Duty Factor (dB)	Total PSD With Duty Factor (dBm)	Max. Limit (dBm/MHz)	Pass / Fail
		Chain 0	Chain 1	Chain 2	Chain 3	Chain 4	Chain 5	Chain 6	Chain 7				
42+155	5210	-2.57	1.30	-2.05	-2.71	-	-	-	-	0.16	4.86	13.30	Pass
	5775	Test results refer to U_NII-3 data											

- Note:**
- Method a) of power density measurement of KDB 662911 is using for calculating total power density. Total power density is summing entire spectra across corresponding frequency bins on the various outputs by computer.
 - Directional gain = 9.7dBi > 6dBi, so the power density limit shall be reduced to $17-(9.7-6) = 13.30\text{dBm}$.
 - Refer to section 3.3 for duty cycle spectrum plot.

Spectrum Plot of Worst Value

802.11a / Chain 5 : CH36

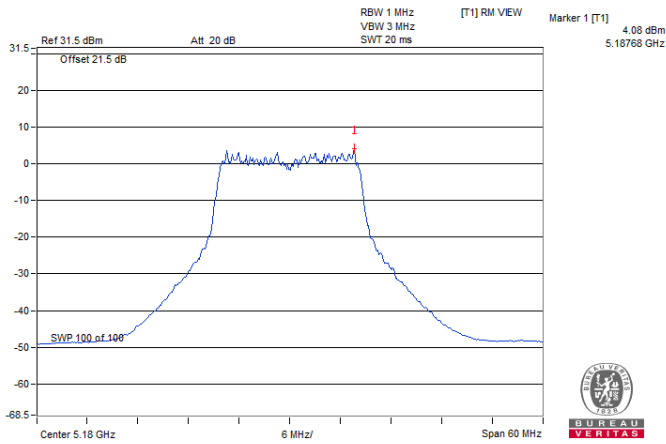

802.11ac (VHT20) / Chain 4 : CH48

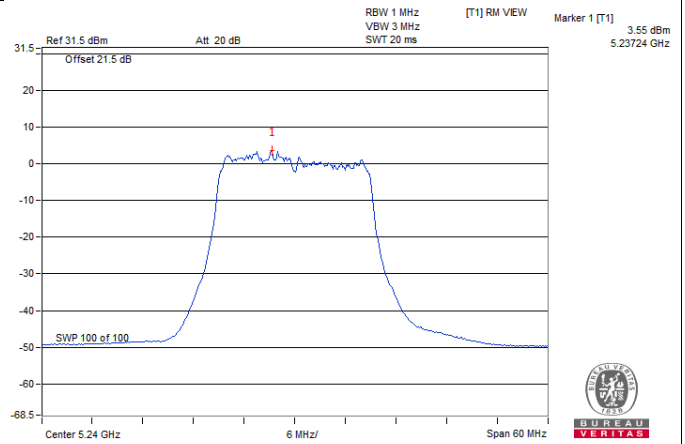

802.11ac (VHT40) / Chain 5 : CH46

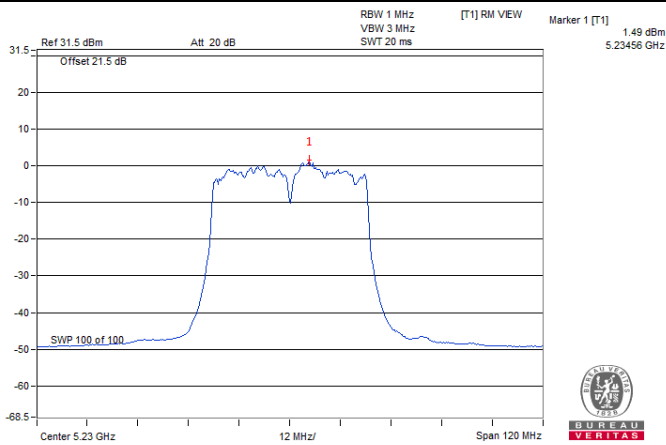

802.11ac (VHT80) / Chain 2 : CH42

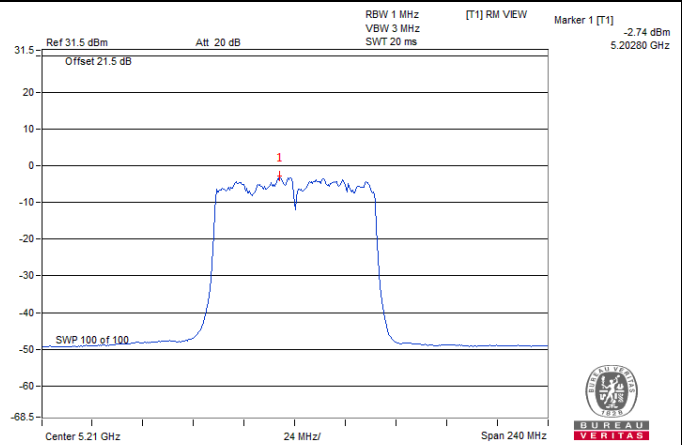

802.11ac (VHT80+80) / Chain 0 : CH42

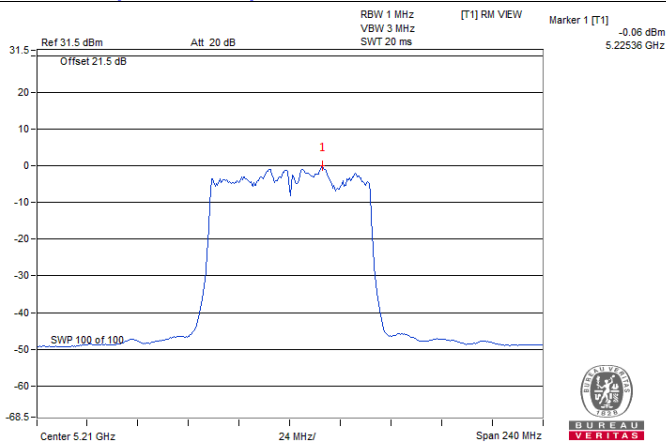

Spectrum Plot of Worst Value

802.11ax (HE20) / Chain 7 : CH48

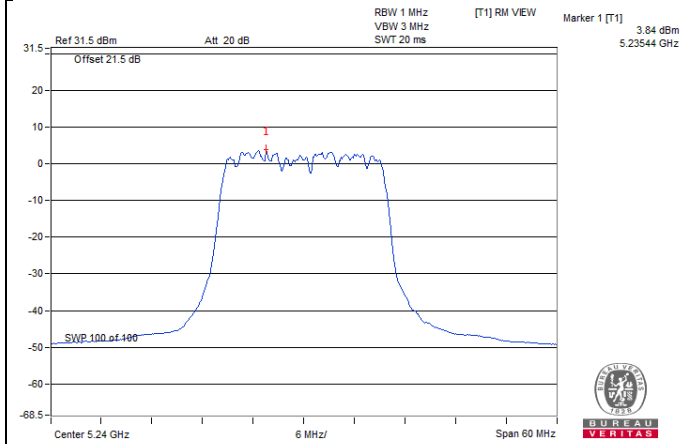

802.11ax (HE40) / Chain 2: CH46

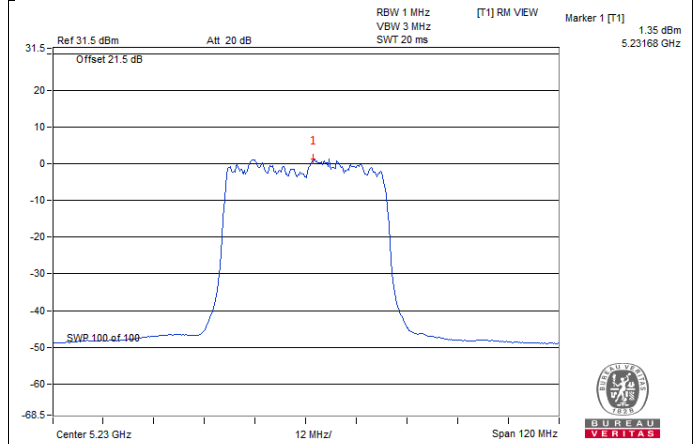

802.11ax (HE80) / Chain 2 : CH42

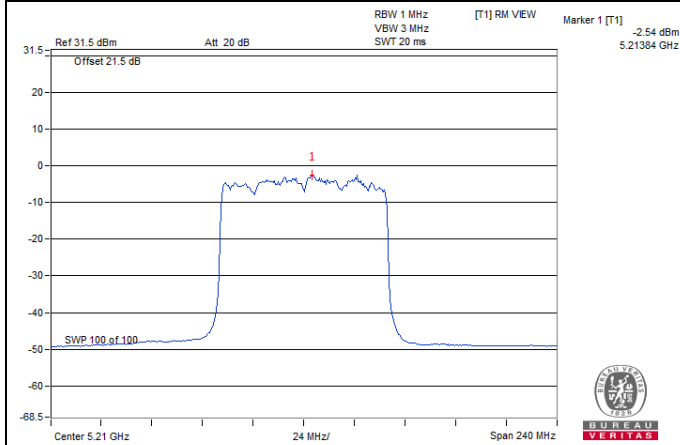

802.11ax (HE80+80) / Chain 1: CH42

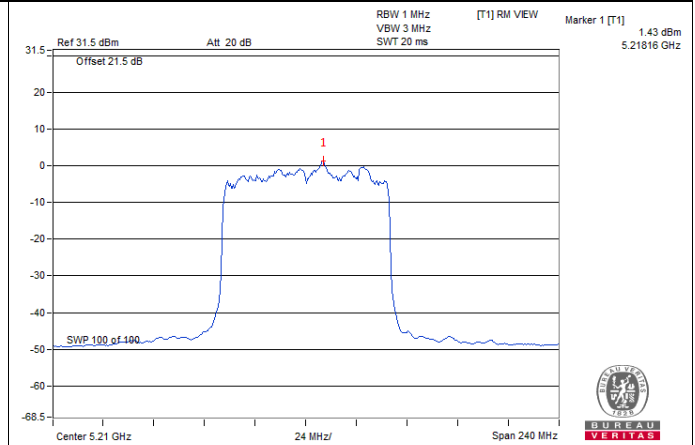

For U-NII-3:

802.11a

Chan.	Freq. (MHz)	PSD W/O Duty Factor (dBm/300kHz)								Duty Factor (dB)	Total PSD With Duty Factor		Total PSD With Duty Factor (dBm/500kHz)	Limit (dBm/500kHz)	Pass /Fail
		Chain 0	Chain 1	Chain 2	Chain 3	Chain 4	Chain 5	Chain 6	Chain 7		mW/300 kHz	dBm/300 kHz			
149	5745	-5.89	-5.65	-5.77	-4.76	-4.83	-5.42	-5.23	-5.00	0.52	2.361	3.73	5.95	25.73	Pass
157	5785	-5.59	-6.38	-4.85	-5.88	-5.70	-4.30	-5.47	-5.48	0.52	2.2994	3.62	5.84	25.73	Pass
165	5825	-5.03	-6.10	-5.04	-5.74	-5.56	-5.23	-5.46	-5.10	0.52	2.3109	3.64	5.86	25.73	Pass

- Note: 1. Method b) Measure and sum spectral maxima across the outputs of KDB 662911 is using for calculating total power density.
 2. Directional gain = 10.27dBi > 6dBi, so the power density limit shall be reduced to 30-(10.27-6) = 25.73dBm.
 3. Refer to section 3.3 for duty cycle spectrum plot.

802.11ac (VHT20)

Chan.	Freq. (MHz)	PSD W/O Duty Factor (dBm/300kHz)								Duty Factor (dB)	Total PSD With Duty Factor		Total PSD With Duty Factor (dBm/500kHz)	Limit (dBm/500kHz)	Pass /Fail
		Chain 0	Chain 1	Chain 2	Chain 3	Chain 4	Chain 5	Chain 6	Chain 7		mW/300 kHz	dBm/300 kHz			
149	5745	-5.67	-5.39	-4.86	-4.46	-6.01	-5.38	-5.54	-5.03	0.17	2.3784	3.76	5.98	25.73	Pass
157	5785	-6.07	-5.79	-4.91	-4.57	-4.67	-4.95	-5.44	-5.12	0.17	2.4372	3.87	6.09	25.73	Pass
165	5825	-6.34	-5.38	-4.75	-5.00	-5.46	-4.39	-5.71	-4.93	0.17	2.4115	3.82	6.04	25.73	Pass

- Note: 1. Method b) Measure and sum spectral maxima across the outputs of KDB 662911 is using for calculating total power density.
 2. Directional gain = 10.27dBi > 6dBi, so the power density limit shall be reduced to 30-(10.27-6) = 25.73dBm.
 3. Refer to section 3.3 for duty cycle spectrum plot.

802.11ac (VHT40)

Chan.	Freq. (MHz)	PSD W/O Duty Factor (dBm/300kHz)								Duty Factor (dB)	Total PSD With Duty Factor		Total PSD With Duty Factor (dBm/500kHz)	Limit (dBm/500kHz)	Pass /Fail
		Chain 0	Chain 1	Chain 2	Chain 3	Chain 4	Chain 5	Chain 6	Chain 7		mW/300 kHz	dBm/300 kHz			
151	5755	-9.35	-9.61	-8.55	-8.24	-8.35	-8.68	-9.03	-8.44	0.16	1.0651	0.27	2.49	25.73	Pass
159	5795	-8.87	-9.44	-9.50	-7.92	-8.86	-8.65	-9.03	-8.77	0.16	1.0414	0.18	2.40	25.73	Pass

- Note: 1. Method b) Measure and sum spectral maxima across the outputs of KDB 662911 is using for calculating total power density.
 2. Directional gain = 10.27dBi > 6dBi, so the power density limit shall be reduced to 30-(10.27-6) = 25.73dBm.
 3. Refer to section 3.3 for duty cycle spectrum plot.

802.11ac (VHT80)

Chan.	Freq. (MHz)	PSD W/O Duty Factor (dBm/300kHz)								Duty Factor (dB)	Total PSD With Duty Factor		Total PSD With Duty Factor (dBm/500kHz)	Limit (dBm/500kHz)	Pass /Fail
		Chain 0	Chain 1	Chain 2	Chain 3	Chain 4	Chain 5	Chain 6	Chain 7		mW/300 kHz	dBm/300 kHz			
155	5775	-11.96	-12.32	-10.74	-10.62	-11.75	-11.17	-11.91	-11.63	0.16	0.56966	-2.44	-0.22	25.73	Pass

- Note: 1. Method b) Measure and sum spectral maxima across the outputs of KDB 662911 is using for calculating total power density.
 2. Directional gain = 10.27dBi > 6dBi, so the power density limit shall be reduced to 30-(10.27-6) = 25.73dBm.
 3. Refer to section 3.3 for duty cycle spectrum plot.

802.11ac (VHT80+80)

Chan.	Freq. (MHz)	PSD W/O Duty Factor (dBm/300kHz)								Duty Factor (dB)	Total PSD With Duty Factor		Total PSD With Duty Factor (dBm/500kHz)	Limit (dBm/500kHz)	Pass /Fail	
		Chain 0	Chain 1	Chain 2	Chain 3	Chain 4	Chain 5	Chain 6	Chain 7		mW/300 kHz	dBm/300 kHz				
42	5210	Test results refer to U_NII-1 data														
155	5775	-	-	-	-	-9.07	-7.66	-7.60	-7.12	0.16	0.6631	-1.78	0.44	25.73	Pass	

- Note: 1. Method b) Measure and sum spectral maxima across the outputs of KDB 662911 is using for calculating total power density.
 2. Directional gain = 10.27dBi > 6dBi, so the power density limit shall be reduced to 30-(10.27-6) = 25.73dBm.
 3. Refer to section 3.3 for duty cycle spectrum plot.

802.11ax (HE20)

Chan.	Freq. (MHz)	PSD W/O Duty Factor (dBm/300kHz)								Duty Factor (dB)	Total PSD With Duty Factor		Total PSD With Duty Factor (dBm/500kHz)	Limit (dBm/500kHz)	Pass /Fail
		Chain 0	Chain 1	Chain 2	Chain 3	Chain 4	Chain 5	Chain 6	Chain 7		mW/300 kHz	dBm/300 kHz			
149	5745	-5.80	-5.93	-6.02	-5.47	-4.51	-6.26	-6.50	-6.54	0.16	2.0884	3.20	5.42	25.73	Pass
157	5785	-6.78	-6.69	-5.18	-6.31	-6.20	-5.04	-6.34	-6.09	0.16	1.993	3.00	5.22	25.73	Pass
165	5825	-5.50	-6.46	-5.61	-6.19	-5.95	-5.30	-6.19	-6.22	0.16	2.0514	3.12	5.34	25.73	Pass

- Note:
- Method b) Measure and sum spectral maxima across the outputs of KDB 662911 is using for calculating total power density.
 - Directional gain = 10.27dBi > 6dBi, so the power density limit shall be reduced to $30-(10.27-6) = 25.73$ dBm.
 - Refer to section 3.3 for duty cycle spectrum plot.

802.11ax (HE40)

Chan.	Freq. (MHz)	PSD W/O Duty Factor (dBm/300kHz)								Duty Factor (dB)	Total PSD With Duty Factor		Total PSD With Duty Factor (dBm/500kHz)	Limit (dBm/500kHz)	Pass /Fail
		Chain 0	Chain 1	Chain 2	Chain 3	Chain 4	Chain 5	Chain 6	Chain 7		mW/300 kHz	dBm/300 kHz			
151	5755	-8.66	-8.80	-8.15	-8.77	-7.33	-8.16	-8.87	-8.51	0.18	1.1621	0.65	2.87	25.73	Pass
159	5795	-9.02	-9.06	-8.71	-8.77	-8.58	-8.67	-8.30	-9.07	0.18	1.0631	0.27	2.49	25.73	Pass

- Note:
- Method b) Measure and sum spectral maxima across the outputs of KDB 662911 is using for calculating total power density.
 - Directional gain = 10.27dBi > 6dBi, so the power density limit shall be reduced to $30-(10.27-6) = 25.73$ dBm.
 - Refer to section 3.3 for duty cycle spectrum plot.

802.11ax (HE80)

Chan.	Freq. (MHz)	PSD W/O Duty Factor (dBm/300kHz)								Duty Factor (dB)	Total PSD With Duty Factor		Total PSD With Duty Factor (dBm/500kHz)	Limit (dBm/500kHz)	Pass /Fail
		Chain 0	Chain 1	Chain 2	Chain 3	Chain 4	Chain 5	Chain 6	Chain 7		mW/300 kHz	dBm/300 kHz			
155	5775	-11.91	-11.47	-11.17	-11.10	-10.56	-11.85	-10.96	-11.33	0.16	0.59671	-2.24	-0.02	25.73	Pass

- Note:
- Method b) Measure and sum spectral maxima across the outputs of KDB 662911 is using for calculating total power density.
 - Directional gain = 10.27dBi > 6dBi, so the power density limit shall be reduced to $30-(10.27-6) = 25.73$ dBm.
 - Refer to section 3.3 for duty cycle spectrum plot.

802.11ax (HE80+80)

Chan.	Freq. (MHz)	PSD W/O Duty Factor (dBm/300kHz)								Duty Factor (dB)	Total PSD With Duty Factor		Total PSD With Duty Factor (dBm/500kHz)	Limit (dBm/500kHz)	Pass /Fail
		Chain 0	Chain 1	Chain 2	Chain 3	Chain 4	Chain 5	Chain 6	Chain 7		mW/300 kHz	dBm/300 kHz			
42	5210	Test results refer to U_NII-1 data													
155	5775	-	-	-	-	-8.88	-8.46	-8.25	-7.76	0.16	0.5891	-2.30	-0.08	25.73	Pass

- Note:
- Method b) Measure and sum spectral maxima across the outputs of KDB 662911 is using for calculating total power density.
 - Directional gain = 10.27dBi > 6dBi, so the power density limit shall be reduced to $30 - (10.27 - 6) = 25.73\text{dBm}$.
 - Refer to section 3.3 for duty cycle spectrum plot.

Spectrum Plot of Worst Value

802.11a / Chain 5 : CH157

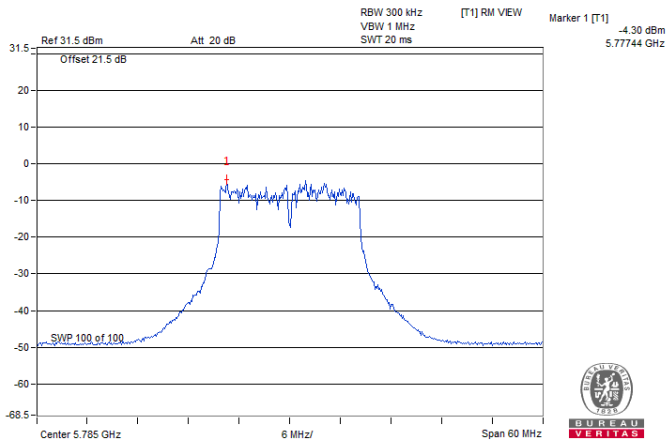

802.11ac (VHT20) / Chain 5 : CH165

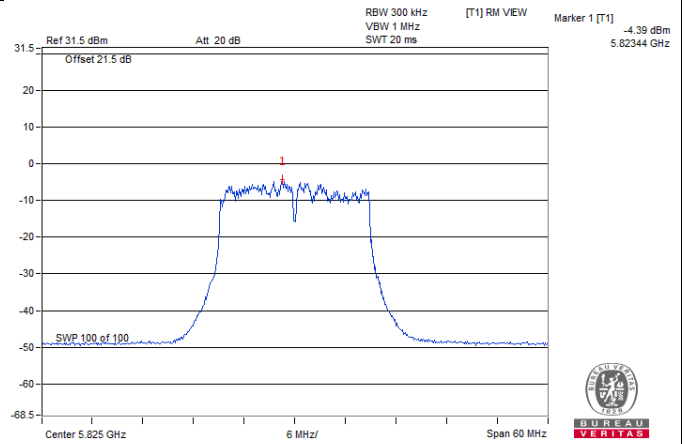

802.11ac (VHT40) / Chain 3 : CH159

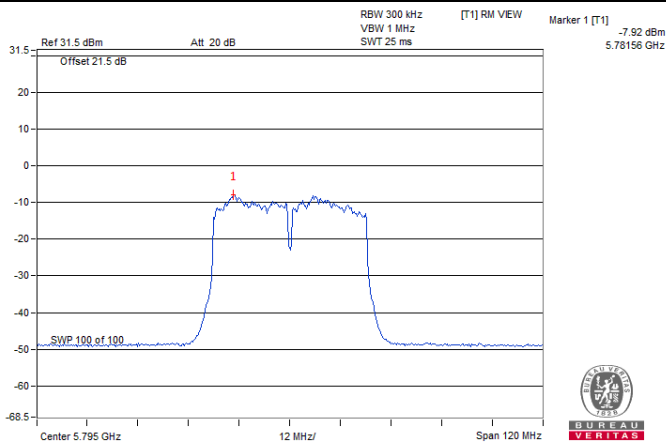

802.11ac (VHT80) / Chain 3 : CH155

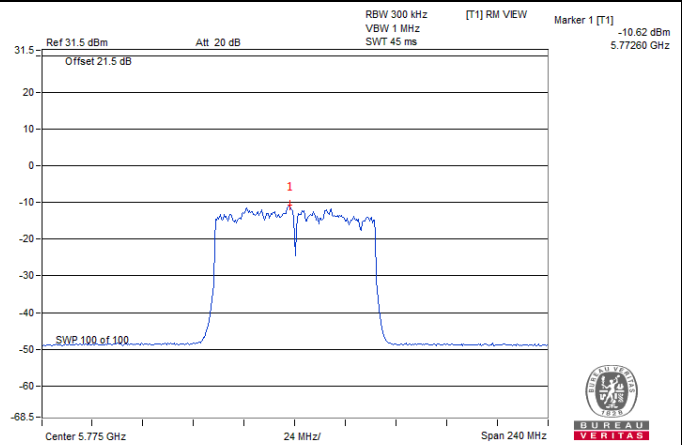

802.11ac (VHT80+80) / Chain 7: CH155

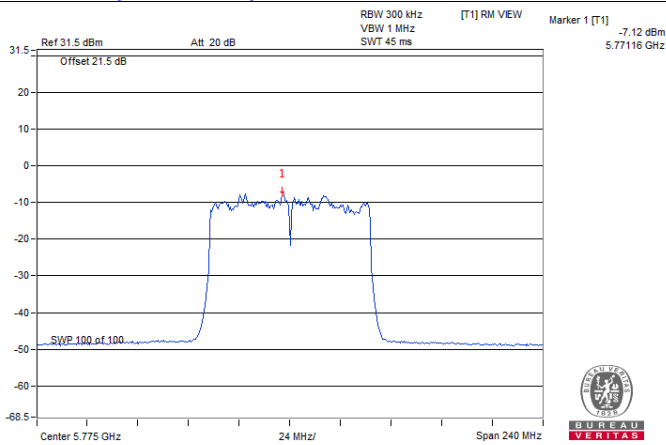

Spectrum Plot of Worst Value

802.11ax (HE20) / Chain 4 : CH149

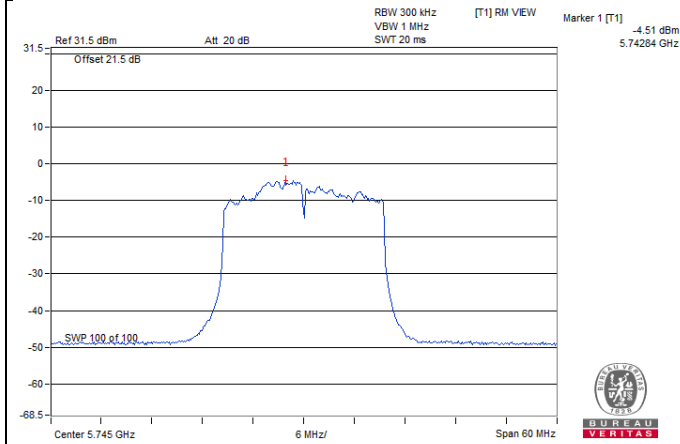

802.11ax (HE40) / Chain 4 : CH151

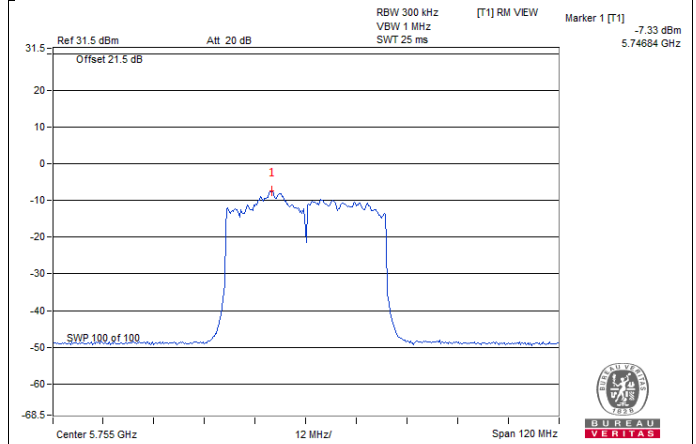

802.11ax (HE80) / Chain 4 : CH155

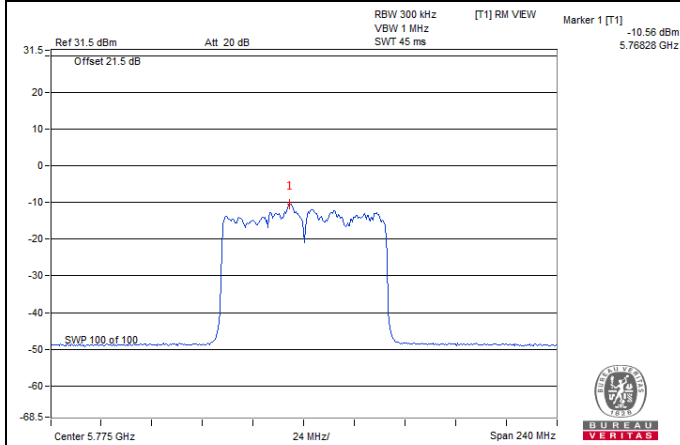

802.11ax (HE80+80) / Chain 7 : CH155

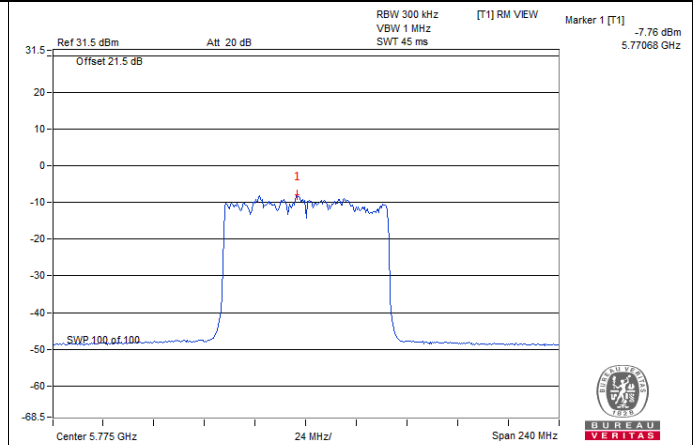

Client Mode

For U-NII-1:

Non-Beamforming Mode

802.11a

Chan.	Freq. (MHz)	PSD W/O Duty Factor (dBm)								Duty Factor (dB)	Total PSD With Duty Factor (dBm)	Max. Limit (dBm/MHz)	Pass / Fail
		Chain 0	Chain 1	Chain 2	Chain 3	Chain 4	Chain 5	Chain 6	Chain 7				
36	5180	-2.56	-3.46	-2.26	-2.95	-4.07	-4.81	-2.30	-2.33	0.52	6.02	7.30	Pass
40	5200	-4.05	-3.35	-4.16	-5.32	-2.70	-1.63	-3.06	-4.88	0.52	5.54	7.30	Pass
48	5240	-2.10	-2.33	-2.61	-3.92	-3.29	-3.07	-2.12	-1.82	0.52	6.42	7.30	Pass

- Note: 1. Method a) of power density measurement of KDB 662911 is using for calculating total power density. Total power density is summing entire spectra across corresponding frequency bins on the various outputs by computer.
 2. Directional gain = 9.7dBi > 6dBi, so the power density limit shall be reduced to $11-(9.7-6) = 7.30\text{dBm}$.
 3. Refer to section 3.3 for duty cycle spectrum plot.

802.11ac (VHT20)

Chan.	Freq. (MHz)	PSD W/O Duty Factor (dBm)								Duty Factor (dB)	Total PSD With Duty Factor (dBm)	Max. Limit (dBm/MHz)	Pass / Fail
		Chain 0	Chain 1	Chain 2	Chain 3	Chain 4	Chain 5	Chain 6	Chain 7				
36	5180	-2.86	-4.23	-2.93	-3.67	-3.10	-2.86	-3.06	-3.89	0.17	5.73	7.30	Pass
40	5200	-3.04	-2.25	-4.68	-4.33	-5.99	-3.20	-3.04	-2.66	0.17	5.53	7.30	Pass
48	5240	-3.02	-3.58	-3.78	-2.94	-4.09	-1.99	-3.26	-3.27	0.17	5.83	7.30	Pass

- Note: 1. Method a) of power density measurement of KDB 662911 is using for calculating total power density. Total power density is summing entire spectra across corresponding frequency bins on the various outputs by computer.
 2. Directional gain = 9.7dBi > 6dBi, so the power density limit shall be reduced to $11-(9.7-6) = 7.30\text{dBm}$.
 3. Refer to section 3.3 for duty cycle spectrum plot.

802.11ac (VHT40)

Chan.	Freq. (MHz)	PSD W/O Duty Factor (dBm)								Duty Factor (dB)	Total PSD With Duty Factor (dBm)	Max. Limit (dBm/MHz)	Pass / Fail
		Chain 0	Chain 1	Chain 2	Chain 3	Chain 4	Chain 5	Chain 6	Chain 7				
38	5190	-7.45	-6.73	-5.06	-8.77	-7.66	-6.81	-5.01	-5.78	0.16	2.54	7.30	Pass
46	5230	-6.03	-6.07	-5.68	-6.65	-6.61	-5.12	-5.96	-4.91	0.16	3.19	7.30	Pass

- Note: 1. Method a) of power density measurement of KDB 662911 is using for calculating total power density. Total power density is summing entire spectra across corresponding frequency bins on the various outputs by computer.
 2. Directional gain = 9.7dBi > 6dBi, so the power density limit shall be reduced to $11-(9.7-6) = 7.30\text{dBm}$.
 3. Refer to section 3.3 for duty cycle spectrum plot.

802.11ac (VHT80)

Chan.	Freq. (MHz)	PSD W/O Duty Factor (dBm)								Duty Factor (dB)	Total PSD With Duty Factor (dBm)	Max. Limit (dBm/MHz)	Pass / Fail
		Chain 0	Chain 1	Chain 2	Chain 3	Chain 4	Chain 5	Chain 6	Chain 7				
42	5210	-9.54	-8.82	-10.33	-9.08	-9.68	-10.36	-8.37	-8.38	0.16	-0.23	7.30	Pass

- Note: 1. Method a) of power density measurement of KDB 662911 is using for calculating total power density. Total power density is summing entire spectra across corresponding frequency bins on the various outputs by computer.
2. Directional gain = 9.7dBi > 6dBi, so the power density limit shall be reduced to $11-(9.7-6) = 7.30$ dBm.
3. Refer to section 3.3 for duty cycle spectrum plot.

802.11ac (VHT80+80)

Chan.	Freq. (MHz)	PSD W/O Duty Factor (dBm)								Duty Factor (dB)	Total PSD With Duty Factor (dBm)	Max. Limit (dBm/MHz)	Pass / Fail
		Chain 0	Chain 1	Chain 2	Chain 3	Chain 4	Chain 5	Chain 6	Chain 7				
42+155	5210	-8.26	-7.02	-6.45	-3.53	-	-	-	-	0.16	0.08	7.30	Pass
	5775	-											

- Note: 1. Method a) of power density measurement of KDB 662911 is using for calculating total power density. Total power density is summing entire spectra across corresponding frequency bins on the various outputs by computer.
2. Directional gain = 9.7dBi > 6dBi, so the power density limit shall be reduced to $11-(9.7-6) = 7.30$ dBm.
3. Refer to section 3.3 for duty cycle spectrum plot.

802.11ax (HE20)

Chan.	Freq. (MHz)	PSD W/O Duty Factor (dBm)								Duty Factor (dB)	Total PSD With Duty Factor (dBm)	Max. Limit (dBm/MHz)	Pass / Fail
		Chain 0	Chain 1	Chain 2	Chain 3	Chain 4	Chain 5	Chain 6	Chain 7				
36	5180	-3.37	-4.09	-2.55	-4.34	-2.18	-4.18	-4.04	-4.40	0.16	5.46	7.30	Pass
40	5200	-4.00	-4.99	-2.63	-4.02	-3.00	-2.49	-2.55	-3.08	0.16	5.76	7.30	Pass
48	5240	-3.64	-3.19	-3.37	-4.19	-3.16	-2.80	-3.30	-3.06	0.16	5.71	7.30	Pass

- Note: 1. Method a) of power density measurement of KDB 662911 is using for calculating total power density. Total power density is summing entire spectra across corresponding frequency bins on the various outputs by computer.
2. Directional gain = 9.7dBi > 6dBi, so the power density limit shall be reduced to $11-(9.7-6) = 7.30$ dBm.
3. Refer to section 3.3 for duty cycle spectrum plot.

802.11ax (HE40)

Chan.	Freq. (MHz)	PSD W/O Duty Factor (dBm)								Duty Factor (dB)	Total PSD With Duty Factor (dBm)	Max. Limit (dBm/MHz)	Pass / Fail
		Chain 0	Chain 1	Chain 2	Chain 3	Chain 4	Chain 5	Chain 6	Chain 7				
38	5190	-8.21	-5.80	-6.50	-6.75	-6.42	-6.76	-6.22	-5.89	0.18	2.52	7.30	Pass
46	5230	-6.15	-7.20	-5.26	-7.10	-5.55	-7.50	-6.19	-5.91	0.18	2.74	7.30	Pass

- Note: 1. Method a) of power density measurement of KDB 662911 is using for calculating total power density. Total power density is summing entire spectra across corresponding frequency bins on the various outputs by computer.
2. Directional gain = 9.7dBi > 6dBi, so the power density limit shall be reduced to $11-(9.7-6) = 7.30\text{dBm}$.
3. Refer to section 3.3 for duty cycle spectrum plot.

802.11ax (HE80)

Chan.	Freq. (MHz)	PSD W/O Duty Factor (dBm)								Duty Factor (dB)	Total PSD With Duty Factor (dBm)	Max. Limit (dBm/MHz)	Pass / Fail
		Chain 0	Chain 1	Chain 2	Chain 3	Chain 4	Chain 5	Chain 6	Chain 7				
42	5210	-9.22	-9.31	-9.13	-11.37	-8.13	-8.36	-10.00	-8.91	0.16	-0.18	7.30	Pass

- Note: 1. Method a) of power density measurement of KDB 662911 is using for calculating total power density. Total power density is summing entire spectra across corresponding frequency bins on the various outputs by computer.
2. Directional gain = 9.7dBi > 6dBi, so the power density limit shall be reduced to $11-(9.7-6) = 7.30\text{dBm}$.
3. Refer to section 3.3 for duty cycle spectrum plot.

802.11ax (HE80+80)

Chan.	Freq. (MHz)	PSD W/O Duty Factor (dBm)								Duty Factor (dB)	Total PSD With Duty Factor (dBm)	Max. Limit (dBm/MHz)	Pass / Fail
		Chain 0	Chain 1	Chain 2	Chain 3	Chain 4	Chain 5	Chain 6	Chain 7				
42+155	5210	-7.37	-6.58	-5.42	-4.96	-	-	-	-	0.16	0.04	7.30	Pass
	5775	-											

- Note: 1. Method a) of power density measurement of KDB 662911 is using for calculating total power density. Total power density is summing entire spectra across corresponding frequency bins on the various outputs by computer.
2. Directional gain = 9.7dBi > 6dBi, so the power density limit shall be reduced to $11-(9.7-6) = 7.30\text{dBm}$.
3. Refer to section 3.3 for duty cycle spectrum plot.

Spectrum Plot of Worst Value

802.11a_Chain 5 / CH40

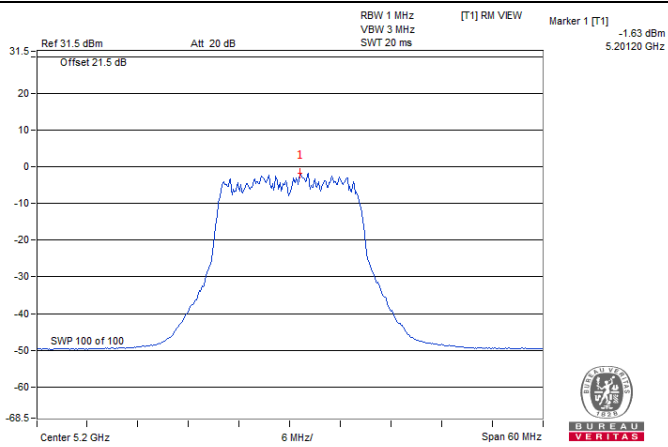

802.11ac (VHT20)_Chain 5 / CH48

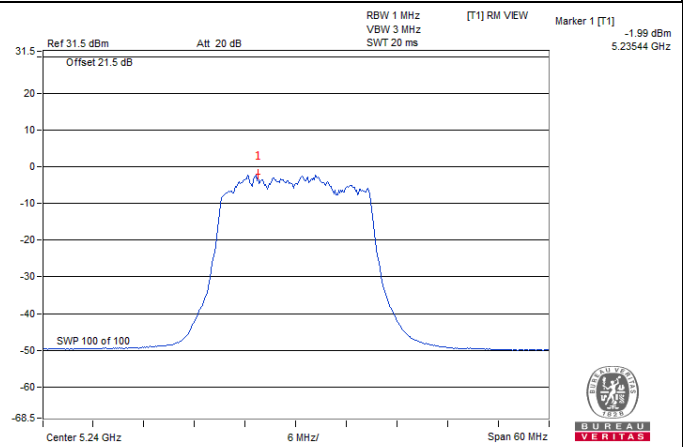

802.11ac (VHT40)_Chain 7 / CH46

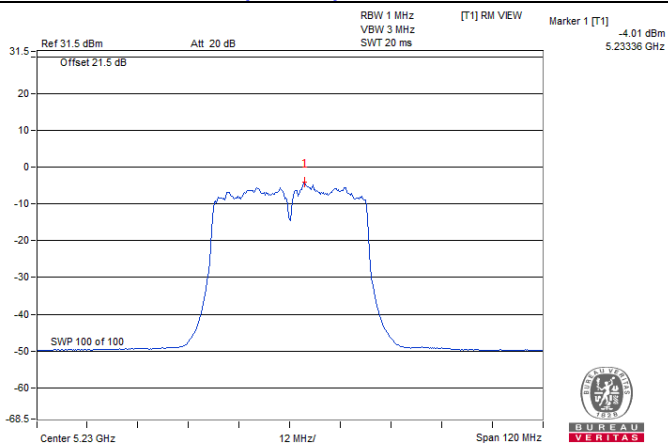

802.11ac (VHT80)_Chain 6 / CH42

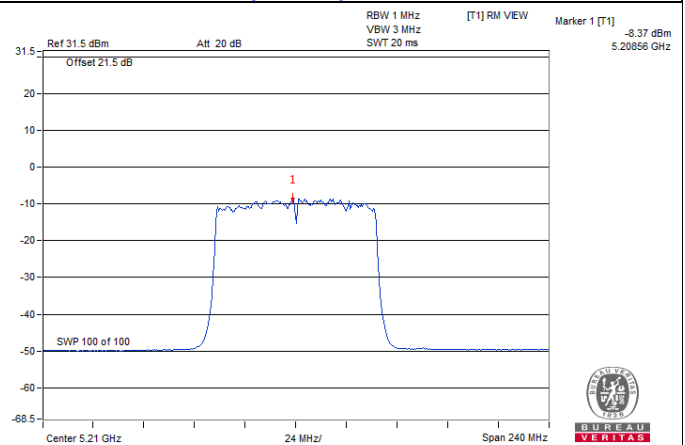

802.11ac (VHT80+80)_Chain 3 / CH42

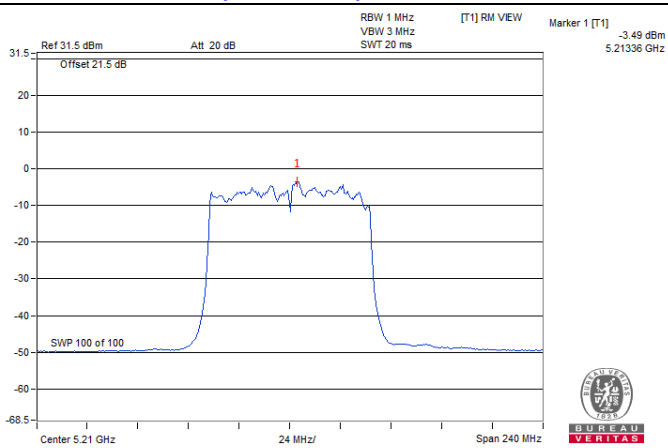

Spectrum Plot of Worst Value

802.11ax (HE20)_Chain 4 / CH36

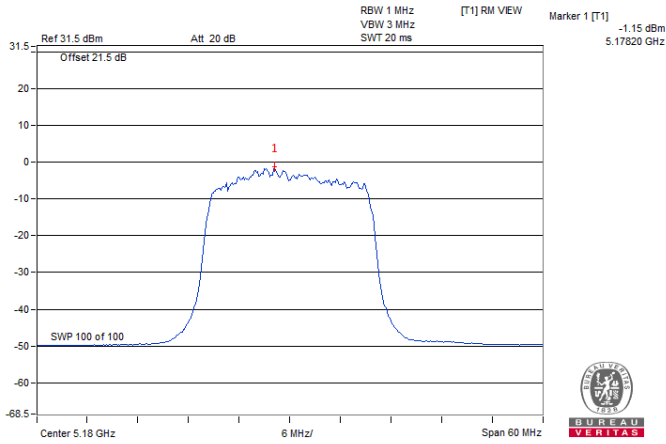

802.11ax (HE40)_Chain 2 / CH46

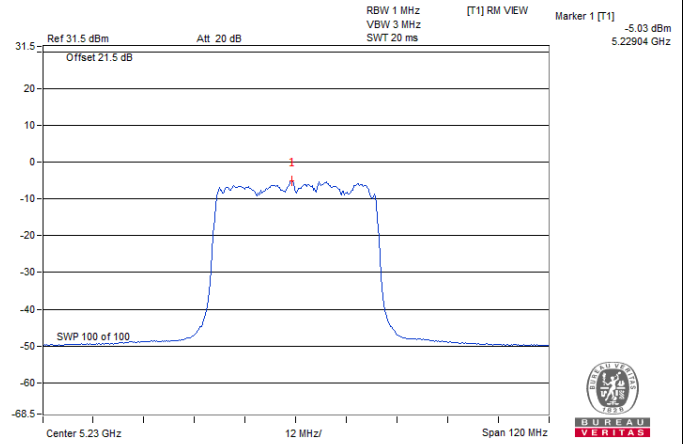

802.11ax (HE80)_Chain 4 / CH42

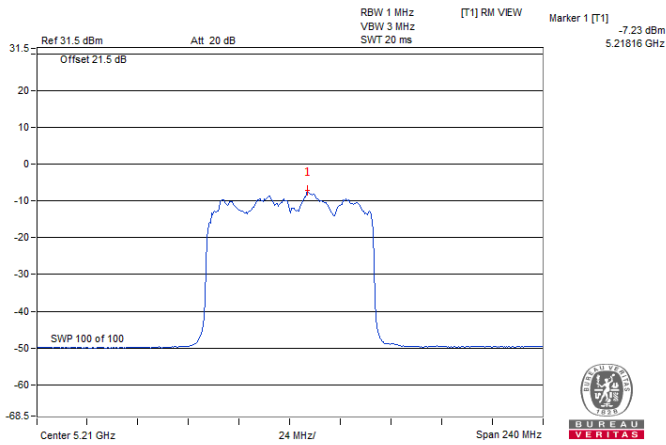

802.11ax (HE80+80)_Chain 3 / CH42

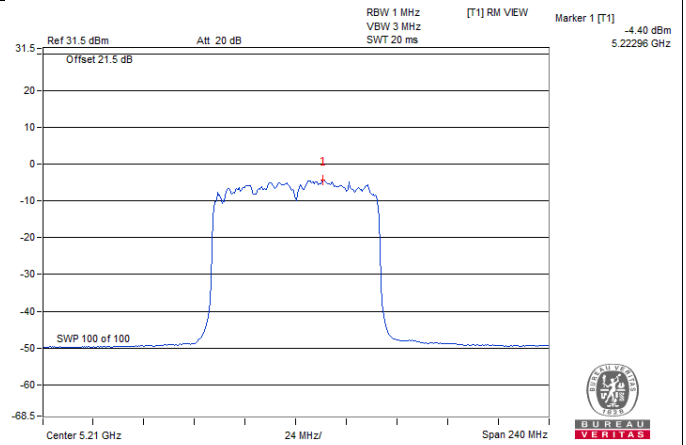

4.6 Frequency Stability Measurement

4.6.1 Limits of Frequency Stability Measurement

The frequency of the carrier signal shall be maintained within band of operation

4.6.2 Test Setup

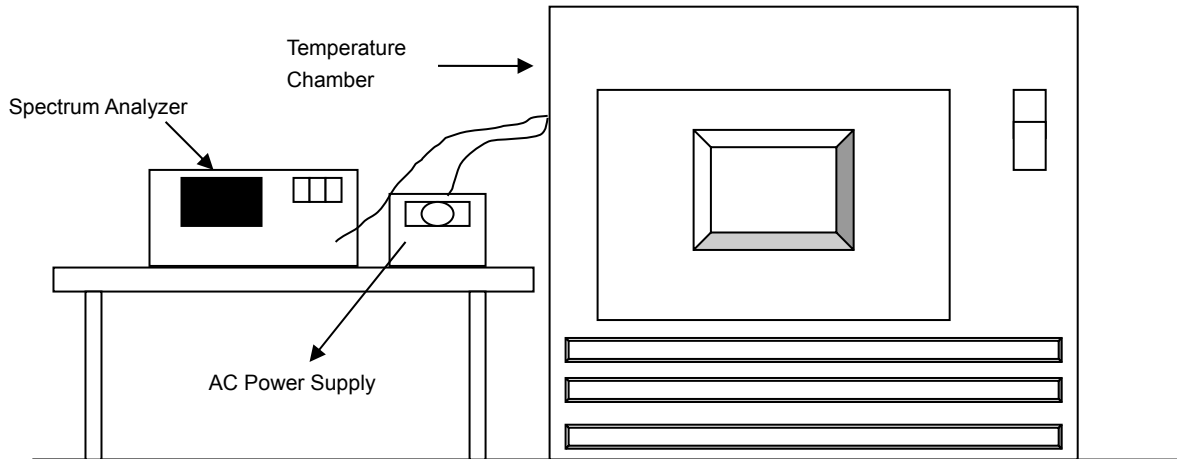

4.6.3 Test Instruments

Refer to section 4.1.2 to get information of above instrument.

4.6.4 Test Procedure

- The EUT was placed inside the environmental test chamber and powered by nominal AC voltage.
- Turn the EUT on and couple its output to a spectrum analyzer.
- Turn the EUT off and set the chamber to the highest temperature specified.
- Allow sufficient time (approximately 30 min) for the temperature of the chamber to stabilize, turn the EUT on and measure the operating frequency after 2, 5, and 10 Minutes.
- Repeat step 2 and 3 with the temperature chamber set to the lowest temperature.
- The test chamber was allowed to stabilize at +20 degree C for a minimum of 30 Minutes. The supply voltage was then adjusted on the EUT from 85% to 115% and the frequency record.

4.6.5 Deviation from Test Standard

No deviation.

4.6.6 EUT Operating Condition

Set the EUT transmit at un-modulation mode to test frequency stability.

4.6.7 Test Results

Frequency Stability Versus Temp.									
Operating Frequency: 5180 MHz									
TEMP. (°C)	Power Supply (Vac)	0 Minute		2 Minutes		5 Minutes		10 Minutes	
		Measured Frequency (MHz)	Pass/Fail	Measured Frequency (MHz)	Pass/Fail	Measured Frequency (MHz)	Pass/Fail	Measured Frequency (MHz)	Pass/Fail
50	120	5180.0241	PASS	5180.0228	PASS	5180.0215	PASS	5180.0233	PASS
40	120	5180.0035	PASS	5180.0007	PASS	5180.0026	PASS	5180.0009	PASS
30	120	5179.9782	PASS	5179.977	PASS	5179.9752	PASS	5179.9772	PASS
20	120	5180.0257	PASS	5180.0228	PASS	5180.0232	PASS	5180.0235	PASS
10	120	5179.9873	PASS	5179.9861	PASS	5179.9876	PASS	5179.9879	PASS
0	120	5180.0123	PASS	5180.0117	PASS	5180.0143	PASS	5180.0145	PASS
-10	120	5179.9932	PASS	5179.9888	PASS	5179.9883	PASS	5179.99	PASS
-20	120	5180.0108	PASS	5180.0089	PASS	5180.0096	PASS	5180.0088	PASS
-30	120	5180.0066	PASS	5180.0051	PASS	5180.0073	PASS	5180.006	PASS

Frequency Stability Versus Voltage									
Operating Frequency: 5180 MHz									
TEMP. (°C)	Power Supply (Vac)	0 Minute		2 Minutes		5 Minutes		10 Minutes	
		Measured Frequency (MHz)	Pass/Fail	Measured Frequency (MHz)	Pass/Fail	Measured Frequency (MHz)	Pass/Fail	Measured Frequency (MHz)	Pass/Fail
20	138	5180.0253	PASS	5180.0238	PASS	5180.0224	PASS	5180.0244	PASS
	120	5180.0257	PASS	5180.0228	PASS	5180.0232	PASS	5180.0235	PASS
	102	5180.0266	PASS	5180.0235	PASS	5180.0237	PASS	5180.0245	PASS

4.7 6dB Bandwidth Measurement

4.7.1 Limits of 6dB Bandwidth Measurement

The minimum of 6dB Bandwidth Measurement is 0.5MHz.

4.7.2 Test Setup

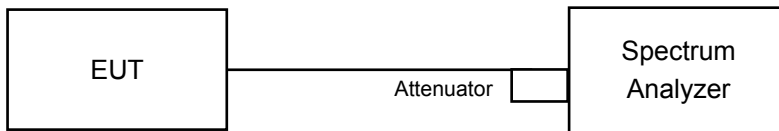

4.7.3 Test Instruments

Refer to section 4.1.2 to get information of above instrument.

4.7.4 Test Procedure

MEASUREMENT PROCEDURE REF

- a. Set resolution bandwidth (RBW) = 100kHz
- b. Set the video bandwidth (VBW) $\geq 3 \times$ RBW, Detector = Peak.
- c. Trace mode = max hold.
- d. Sweep = auto couple.
- e. Measure the maximum width of the emission that is constrained by the frequencies associated with the two amplitude points (upper and lower) that are attenuated by 6 dB relative to the maximum level measured in the fundamental emission

4.7.5 Deviation from Test Standard

No deviation.

4.7.6 EUT Operating Condition

The software provided by client to enable the EUT under transmission condition continuously at lowest, middle and highest channel frequencies individually.

4.7.7 Test Results

Non-Beamforming Mode

802.11a

Channel	Frequency (MHz)	6dB Bandwidth (MHz)								Minimum Limit (MHz)	Pass / Fail
		Chain 0	Chain 1	Chain 2	Chain 3	Chain 4	Chain 5	Chain 6	Chain 7		
149	5745	16.40	16.43	15.81	16.39	16.38	16.40	16.39	16.41	0.5	PASS
157	5785	16.45	16.45	16.45	16.02	16.16	16.42	16.42	16.41	0.5	PASS
165	5825	16.39	16.42	16.42	16.41	16.41	16.39	16.44	16.43	0.5	PASS

802.11ax (HE20)

Channel	Frequency (MHz)	6dB Bandwidth (MHz)								Minimum Limit (MHz)	Pass / Fail
		Chain 0	Chain 1	Chain 2	Chain 3	Chain 4	Chain 5	Chain 6	Chain 7		
149	5745	18.78	18.57	19.00	18.16	15.09	18.84	18.95	18.57	0.5	PASS
157	5785	18.04	18.72	18.42	18.74	18.90	18.69	18.99	18.80	0.5	PASS
165	5825	18.39	18.76	18.86	18.55	18.51	17.13	18.97	18.17	0.5	PASS

802.11ax (HE40)

Channel	Frequency (MHz)	6dB Bandwidth (MHz)								Minimum Limit (MHz)	Pass / Fail
		Chain 0	Chain 1	Chain 2	Chain 3	Chain 4	Chain 5	Chain 6	Chain 7		
151	5755	37.72	37.91	37.53	37.86	37.31	37.74	37.99	37.88	0.5	PASS
159	5795	38.09	37.98	35.49	37.31	35.37	37.56	38.00	37.77	0.5	PASS

802.11ax (HE80)

Channel	Frequency (MHz)	6dB Bandwidth (MHz)								Minimum Limit (MHz)	Pass / Fail
		Chain 0	Chain 1	Chain 2	Chain 3	Chain 4	Chain 5	Chain 6	Chain 7		
155	5775	76.65	73.27	73.04	72.60	74.59	75.46	78.11	77.85	0.5	PASS

802.11ax (HE80+80)

Channel	Frequency (MHz)	6dB Bandwidth (MHz)								Minimum Limit (MHz)	Pass / Fail
		Chain 0	Chain 1	Chain 2	Chain 3	Chain 4	Chain 5	Chain 6	Chain 7		
42+155	5210	-									
	5775	-	-	-	-	74.57	76.25	76.60	75.38	0.5	PASS

Spectrum Plot of Worst Value

802.11a / Chain 2: CH149

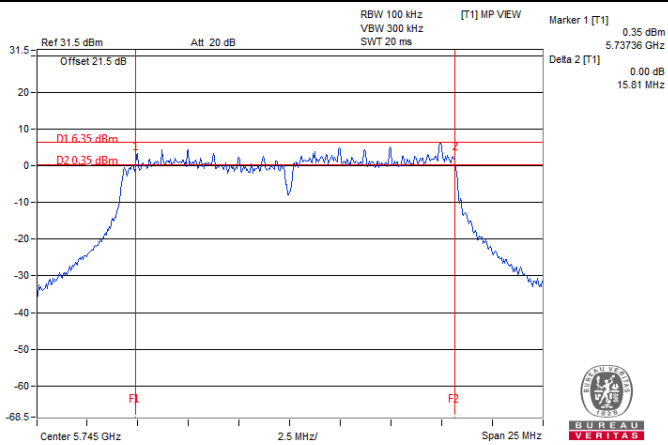

802.11ax (HE20) / Chain 4: CH149

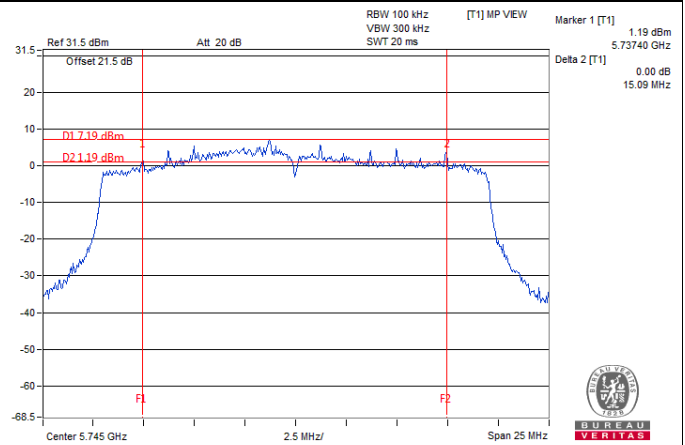

802.11ax (HE40) / Chain 4: CH159

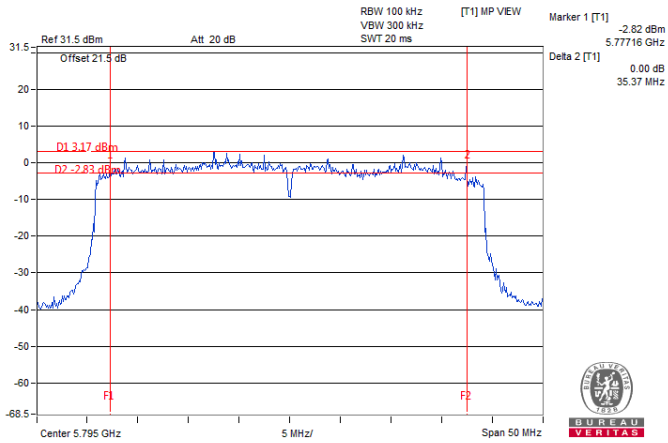

802.11ax (HE80) / Chain 3: CH155

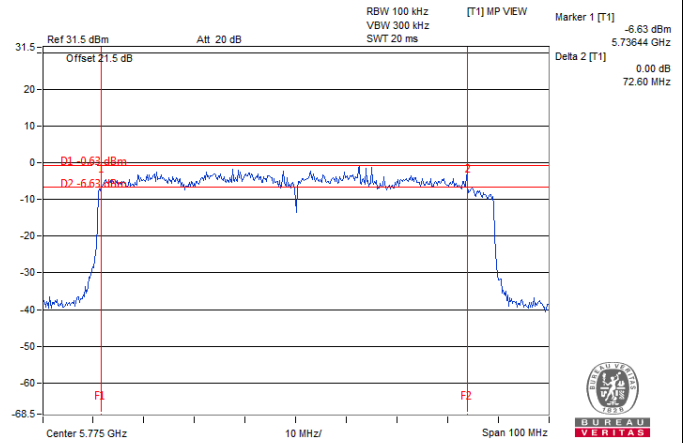

802.11ax (HE80+80) / Chain 4: CH155

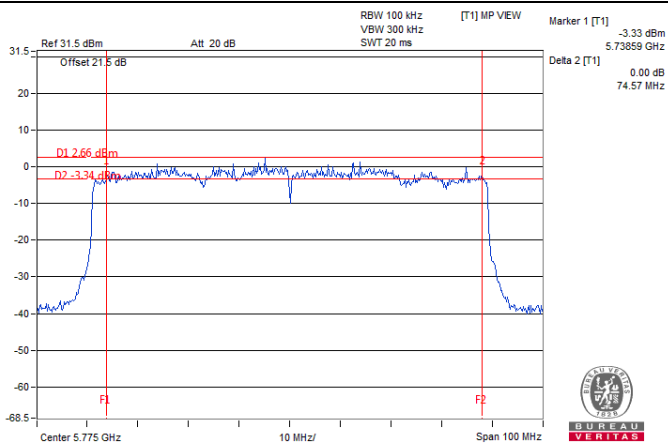

5 Pictures of Test Arrangements

Please refer to the attached file (Test Setup Photo).

Annex A- Radiated Out of Band Emission (OOBE) Measurement (For U-NII-3 band)

802.11a

CH 149 5745 MHz

Horizontal

Vertical

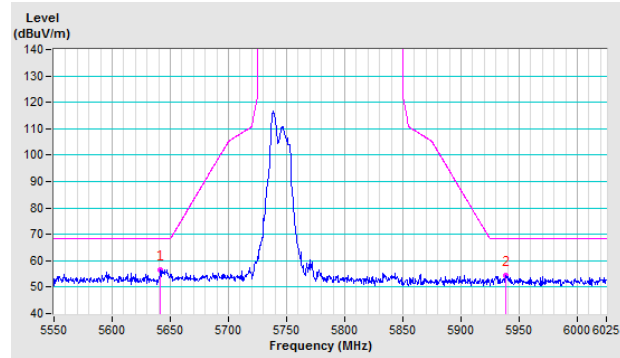
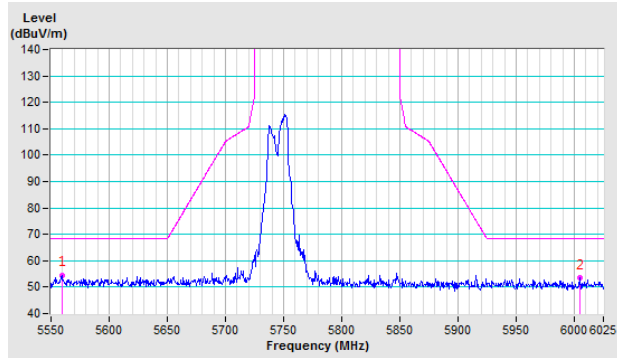

CH 157 5785 MHz

Horizontal

Vertical

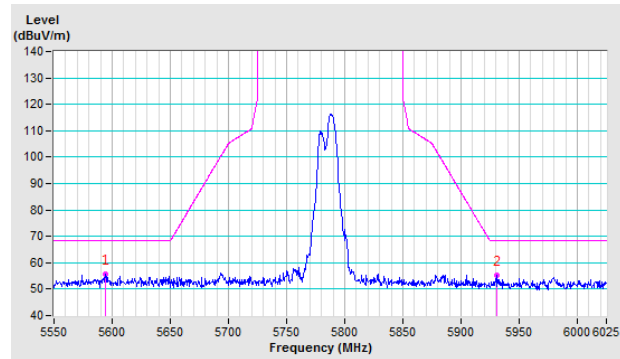
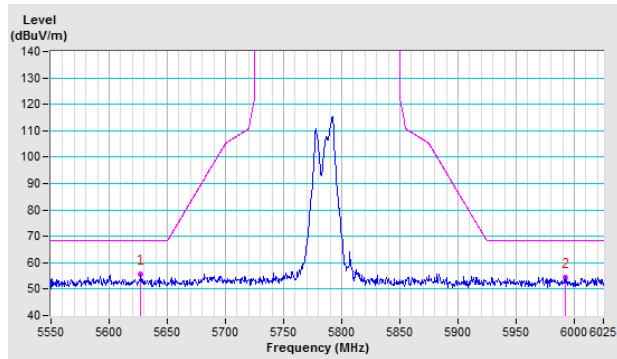

CH 165 5825 MHz

Horizontal

Vertical

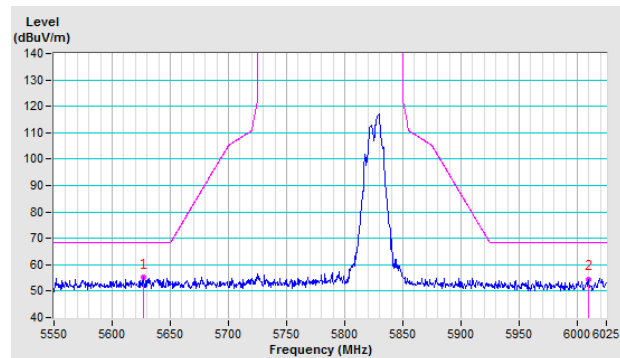
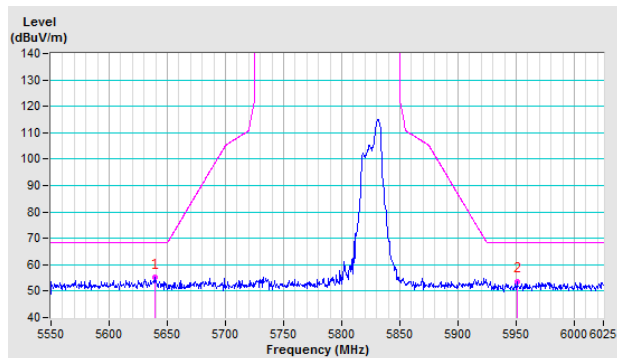

802.11ax (HE20)

CH 149 5745 MHz

Horizontal

Vertical

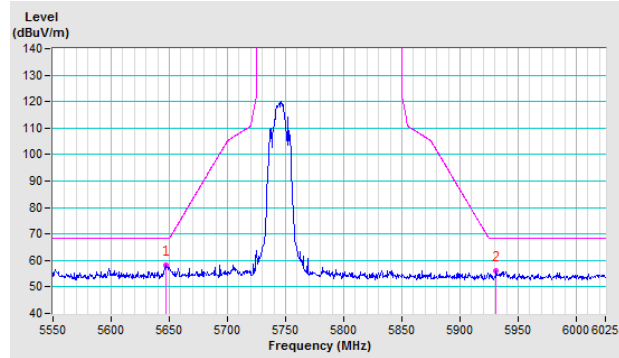
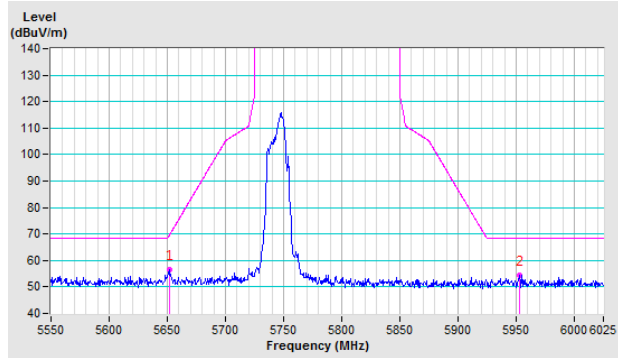

CH 157 5785 MHz

Horizontal

Vertical

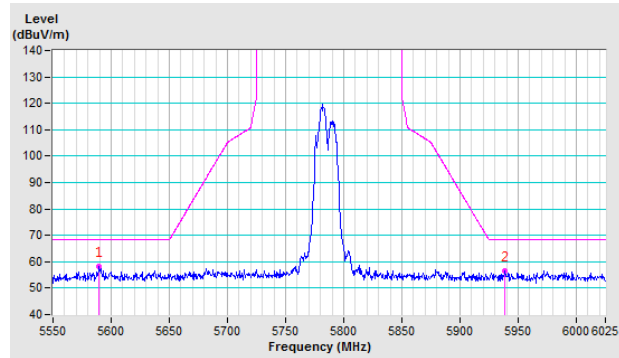
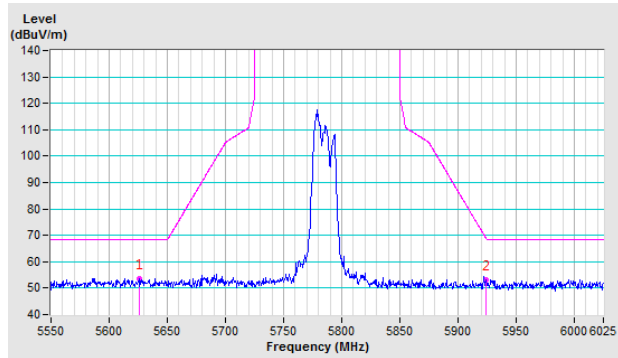

CH 165 5825 MHz

Horizontal

Vertical

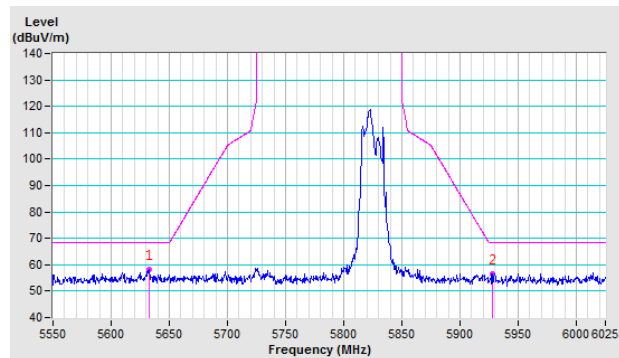
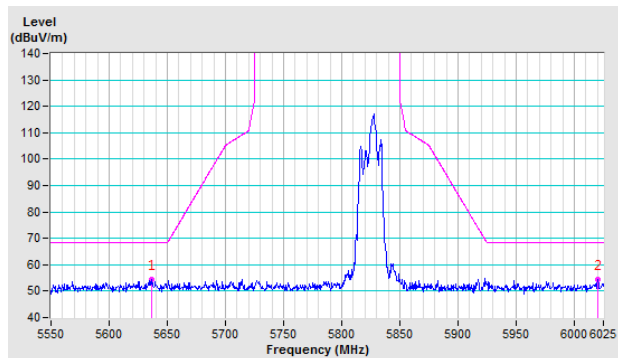

802.11ax (HE40)

CH 151 5755 MHz

Horizontal

Vertical

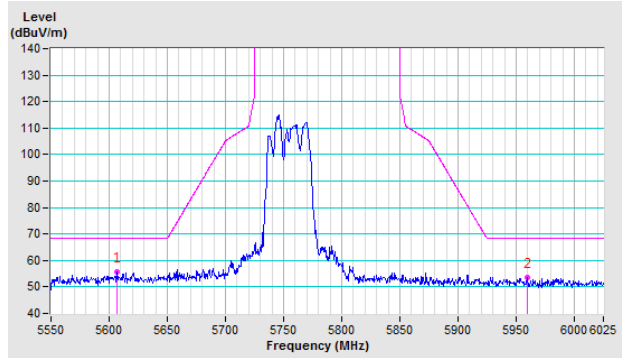
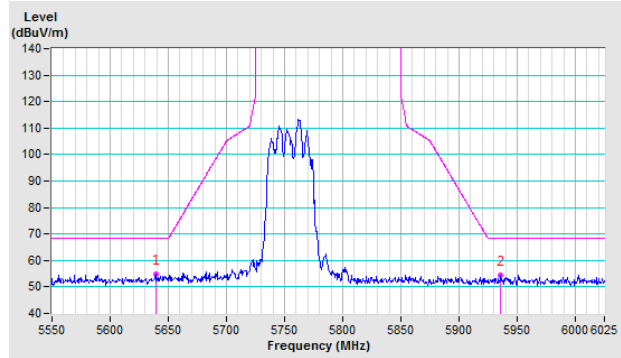

CH 159 5795 MHz

Horizontal

Vertical

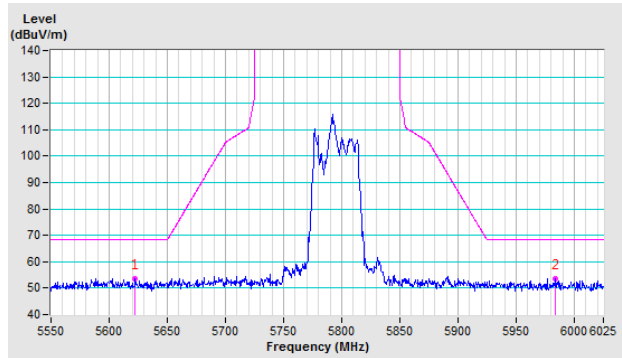
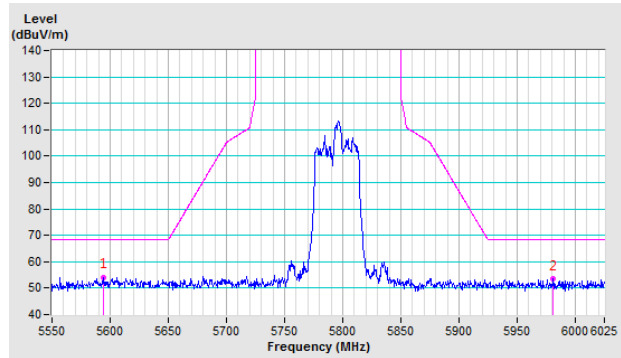

802.11ax (HE80)

CH 155 5775 MHz

Horizontal

Vertical

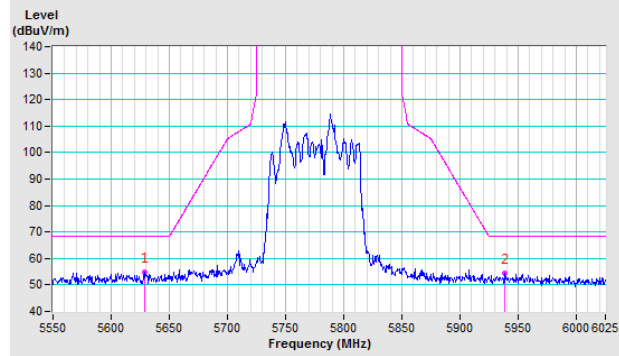
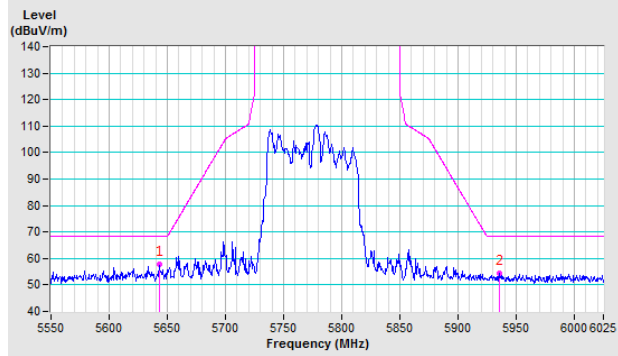

802.11ax (HE80+80)

CH 42+155 5210+5775 MHz

Horizontal

Vertical

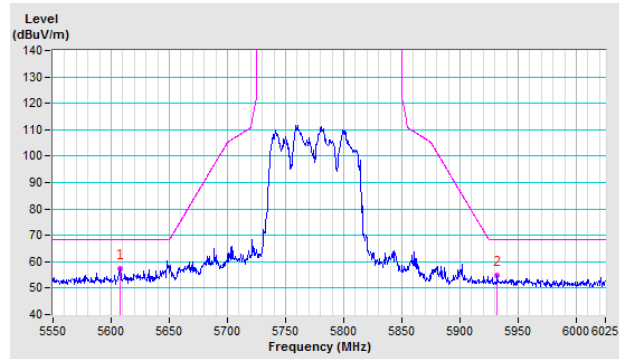
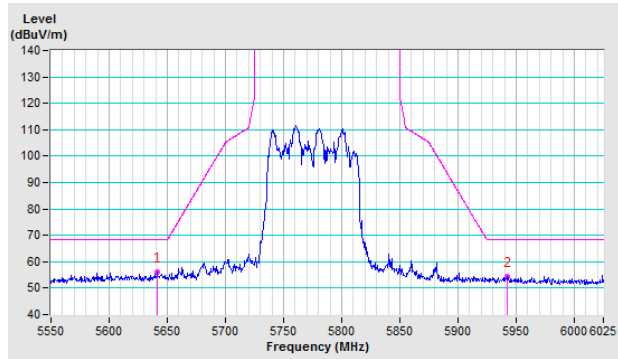

Appendix – Information of the Testing Laboratories

We, Bureau Veritas Consumer Products Services (H.K.) Ltd., Taoyuan Branch, were founded in 1988 to provide our best service in EMC, Radio, Telecom and Safety consultation. Our laboratories are FCC recognized accredited test firms and accredited according to ISO/IEC 17025.

If you have any comments, please feel free to contact us at the following:

Linkou EMC/RF Lab

Tel: 886-2-26052180

Fax: 886-2-26051924

Hsin Chu EMC/RF/Telecom Lab

Tel: 886-3-6668565

Fax: 886-3-6668323

Hwa Ya EMC/RF/Safety Lab

Tel: 886-3-3183232

Fax: 886-3-3270892

Email: service.adt@tw.bureauveritas.com

Web Site: www.bureauveritas-adt.com

The address and road map of all our labs can be found in our web site also.

--- END ---