



# **GigaSpire BLAST Installation Guide**





# Contents

<b>About this Guide</b> .....	<b>5</b>
<b>Chapter 1: GigaSpire BLAST u4 Overview</b> .....	<b>7</b>
GigaSpire Mesh BLAST® u4m Overview.....	12
Agency Listing.....	16
Site Preparation .....	18
Before you Begin.....	18
Introduction.....	19
<b>Chapter 2: Installation</b> .....	<b>23</b>
Installation Tips .....	23
Installation Variables.....	24
Unpacking the GigaSpire u4/u4m .....	25
Tabletop Mounting Dimensions .....	26
Wall Mounting Dimensions.....	27
Tabletop Mounting the u4/u4m.....	27
Wall Mounting the u4/u4m .....	28
Additional Mounting Considerations .....	29

---

<b>Chapter 3: Final Set-up and Testing .....</b>	<b>31</b>
<b>BLAST u4/u4m Reset Behavior .....</b>	<b>31</b>
<b>Powering the BLAST u4/u4m.....</b>	<b>33</b>
<b>Connecting to the Internet.....</b>	<b>34</b>
<b>LED States - Power Off &amp; Boot-up .....</b>	<b>35</b>
<b>LED States - BLAST LED Status.....</b>	<b>35</b>
<b>LED States - Samsung Smart Things.....</b>	<b>36</b>
<b>LED States - Mesh Mode .....</b>	<b>37</b>
<b>Wall Mount Template.....</b>	<b>39</b>

---

## About this Guide

This document provides general installation practices for the Calix GigaSpire BLAST U4 and the GigaSpire Mesh BLAST u4m.

This document also provides a general description of the products, and guidance for planning, site preparation, power installation, splicing to the outside plant, and basic troubleshooting.

### Intended Audiences

This document is intended for use by network planning engineers, outside plant engineers, field support personnel, and craft personnel responsible for installation and maintenance of Calix premises equipment.

### Federal Communications Commission (FCC) Statement

This equipment has been tested and found to comply with the limits for a Class B digital device, pursuant to Part 15 of the FCC rules. These limits are designed to provide reasonable protection against harmful interference when the equipment is operated in a commercial environment. This equipment generates, uses, and can radiate radio frequency energy, and, if not installed and used in accordance with the instruction manual, may cause interference to radio communications. Operation of this equipment in a residential area may cause harmful interference; the user will be required to correct the interference at his expense.

### Safety Notices

This document uses the following safety notice conventions.



**DANGER!** Danger indicates the presence of a hazard that will cause severe personal injury or death if not avoided.



**WARNING!** Warning indicates the presence of a hazard that can cause severe personal injury if not avoided.



**CAUTION!** Caution indicates the presence of a hazard that can cause minor to

moderate personal injury if not avoided.

**ALERT!** Alert indicates the presence of a hazard that can cause damage to equipment or software, loss of data, or service interruption if not avoided.



**DANGER! CLASS 1 LASER PRODUCT. INVISIBLE LASER RADIATION MAY BE PRESENT.** Fiber optic radiation can cause severe eye damage or blindness. Do not look into the open end of an optical fiber.

---

### **IMPORTANT SAFETY INSTRUCTIONS**

When using your equipment, basic safety precautions must always be followed to reduce the risk of fire, electric shock, and injury to persons, including the following:

- Do not use this product near water. For example, near a bathtub, washbowl, kitchen sink, or laundry tub, in a wet basement, or near a swimming pool.
- Use only the power cord indicated in this manual.
- For external power supplies, the external power supply used in this device is to be Class II or a Limited Power Source (LPS) power supply.



## Chapter 1

# GigaSpire BLAST u4 Overview

The Calix GigaSpire BLAST u4 is a new generation smart home system that extends the access network into the home and acts as a strategic location for control of the ultimate Wi-Fi experience. In addition to supporting broadband connectivity of data and video services, this intelligent, high-performance system offers the latest 802.11ax 'Wi-Fi 6' technology. The BLAST u4 provides switching and routing functions that support multi-Gigabit throughput for IPTV video and data services.

**Note:** The GigaSpire BLAST u4 and the GigaSpire Mesh BLAST u4m share the same physical footprint. Mounting is identical although features vary depending on the role the unit plays in the network.

The GigaSpire BLAST u4 is a premium smart home system that delivers the latest 'Wi-Fi 6' certified technology (802.11ax). The BLAST u4 uses a Gigabit Ethernet link at the subscriber's premises to provide carrier-class Wi-Fi and Gigabit Ethernet interfaces for customer multi-media devices. The BLAST u4 enables residential subscribers to receive Gigabit broadband data and Internet Protocol (IP) video services. Using the latest 802.11ax technology in both the 2.4 and 5 GHz radios, the BLAST u4 incorporates dual band 2x2 streams of Wi-Fi delivery (2x2 @ 2.4 GHz and 2x2 @ 5 GHz). In addition, with multi-user multiple-input and multiple-output (MU-MIMO) plus beamforming, the BLAST u4 allows service providers to extend the access network inside the home and establish a strategic location for the delivery and control of broadband services. A USB port is available for other connectivity applications.

With Wi-Fi being the de facto wireless data communication technology of choice for consumers, Calix engineered the GigaSpire BLAST u4 for optimal whole-home coverage with simultaneous dual-band 2.4 GHz and 5 GHz operation and dynamic beamforming at 2.4GHz and 5 GHz. Leveraging the latest Wi-Fi 6 features, the BLAST u4 provides longer range, higher efficiency and less interference compared to earlier generations of Wi-Fi technology. The BLAST u4 also supports the entire 5 GHz band, including Dynamic Frequency Selection (DFS) channels. The BLAST u4 easily delivers HD and UHD (ultra-HD) video and data throughout a subscriber's home in an increasingly video-rich and mobile broadband environment.

Ensuring consumers can achieve ultra-fast Wi-Fi throughout their premises, the BLAST u4 provides the latest generation of redundant mesh via the Calix Wi-Fi 6 BLAST u4m GigaMesh. With the BLAST u4 as the hub, and the u4m as the satellite, consumers can truly gain the whole home/smart home experience. For even higher mesh performance, multiple u4m systems can be connected to the BLAST u4.

Ensuring consumers can have ultra-fast Wi-Fi throughout their premises, the GigaSpire BLAST u4 provides the latest generation of redundant mesh via the Calix Wi-Fi 6 Mesh BLAST u4m. With the BLAST u4 as the hub, and the Mesh BLAST u4m as the satellite, consumers can gain the entire home/smart home experience. For even higher mesh performance, multiple GigaMesh systems can be connected to the GigaSpire BLAST u4.

With the GigaSpire BLAST u4, Calix has redefined how to install and activate residential services at a subscriber's premises. Using the Calix Smart CommandIQ App feature and a phone or laptop, a field technician can install and apply the subscriber's service profile without special equipment or assistance from the central office. Calix also provides the innovative CSC (Calix Support Cloud (CSC)), which allows the service provider to configure, activate and upgrade the GigaSpire BLAST u4 quickly from a remote location using in-band management or TR-069. Extensive troubleshooting capabilities, remote software downloads, and easy-to-use service activation features ensure that services are delivered and maintained without needless truck rolls and hardware upgrades. Employing GigaSpire BLAST u4 systems allows service providers to reduce their operational expenses while effectively delivering the Gigabit experience to their subscribers.

EXOS is the world's only hardware independent, modular, standards-based, always-on smart home operating system. With EXOS, service providers can use the containerized architecture to quickly deploy new services that leverage a range of pre-integrated smart home solutions and thousands of smart devices (for example, enhanced parental controls or network security).





### **Key Attributes - BLAST u4**

#### **Home Gateway**

- Layer 2 bridge and Layer 3 routing for High Speed Internet (HSI) data and IPTV video services
- DHCP server options
- DHCP (IPoE) and PPPoE network connections
- Network Access Translation (NAT), public to private IP addressing
- Configurable IP address schemes, subnets, static-IP addresses
- DNS server
- Bridge port assignment and data traffic mappings
- Port forwarding
- Firewall and security
- Application and website filtering
- Selectable forwarding and blocking policies
- DMZ hosting
- Parental controls, time of day usage
- Denial of service (DoS) protection
- MAC filtering
- Time/Zone support
- Universal Plug-and-Play (UPnP)

**WI-FI**

- 2.4 GHz and 5 GHz, simultaneous dual-band
- 2.4 GHz and 5 GHz 802.11ax (Wi-Fi 6) certified, 802.11a/n/ac compatible
- 4x4 streams (2x2 @ 2.4 GHz and 2x2 @ 5 GHz)
- WPA/WPA2/WPA3; WEP 64/128 bit encryption
- PuF (Physical Unclonable Functions)
- WPS push-button
- 2x2 DL/UL MU-MIMO with beamforming
- 1024 QAM; OFDMA; BSS Coloring
- DCM (Dual Carrier Modulation)
- TWT (Target Wake Time) for IoT clients
- Wi-Fi Redundant Mesh:
  - Self Managed: self configuration, Air time fairness
  - Dynamic Mesh: load balancing, band/node steering; interference management
  - Self Healing; diagnostics; events
- 1 Gigabit Ethernet (GE) WAN interface:
  - 10/100/1000 BASE-T Ethernet, auto-negotiating
- Gigabit Ethernet (GE) LAN interfaces:
  - Two (2) ports of Multi-rate 10/100/1000 BASE-T Ethernet, auto-negotiating for residential IPTV and data services
- USB port:
  - USB 2.0 - Type A host interface
- Supports multiple data service profiles
- Traffic management and Quality of Service (QoS):
  - 802.1Q VLANs
  - 802.1p service prioritization
  - Q-in-Q tagging
  - Multiple VLANs
  - DiffServ
  - Pre-defined QoS on service type
  - LAG of GE ports
  - MAP-T
- IPTV, IGMPv2, future support of IGMPv3:
  - IGMP Snooping and Proxy

- IGMP Fast Leaves
- Gateway Management:
  - CSC (Calix Support Cloud)
  - TR-069
  - Local Home Gateway GUI, access provisionable
  - Remote WAN side GUI access
  - Default username/password
- AC to 12 VDC power adapter

---

## **GigaSpire Mesh BLAST u4m Overview**

The Calix GigaSpire Mesh BLAST u4m is the new generation Wi-Fi 6 mesh satellite that complements the Calix GigaSpire family of products. With the broad portfolio of GigaSpire smart home systems, BLAST<sup>®</sup> u4m extends Wi-Fi coverage and capacity within the subscriber's home. The BLAST<sup>®</sup> u4m Wi-Fi 6 backhaul allows communications service providers (CSPs) to deploy satellites with either a wired or wireless connection to the GigaSpire. When connected wirelessly, the 5.0 GHz 802.11ax 2x2 radio acts as an access point (AP) to the end subscribers' Stations (STA). The BLAST<sup>®</sup> u4m enables subscriber self-installs and results in fewer costly truck rolls. The combined solution – GigaSpire, BLAST<sup>®</sup> u4m satellite and Calix Support Cloud is known as Mesh-Enhanced Carrier Class Wi-Fi and it reduces the time to additional revenue by automating and simplifying the deployment of complex multi-device networks. Besides supporting wired or wireless connectivity of data and video services, this convenient service platform supports the latest Wi-Fi 6 technology, extending the ultimate Wi-Fi to enhance the subscriber experience.



---

## MULTI-GIGABIT SUBSCRIBER EXPERIENCE

The GigaSpire Mesh BLAST<sup>®</sup> u4m is a high performance wireless satellite that delivers the latest 802.11ax Wi-Fi technology in a consumer friendly form factor. Subscribers want their Wi-Fi to work with any device in any location throughout their home. Over time, the numbers, types and locations of these devices has exploded. In response to the rapid adoption of Wi-Fi IoT devices – like door locks, IP cameras and thermostats – CSPs must now provide ubiquitous Wi-Fi coverage. In addition, the demand for video content continues to grow and subscribers expect to watch anywhere on any device. The Calix GigaSpire Mesh BLAST u4m enhances coverage and capacity with the latest 802.11ax Wi-Fi radios, transmitting at the maximum allowable regulatory limits. For homes that need additional coverage and capacity, the Calix Mesh-Enhanced Carrier Class Wi-Fi solution has three components: A GigaSpire, GigaSpire Mesh satellites, and the Calix Cloud. The GigaMesh satellites are optimized for interoperability with GigaSpires 5.0 GHz 802.11ax radio., thus allowing for the delivery of throughput rates of over 1.2 Gbps. Along with the 2x2 2.4 GHz radio, the GigaMesh provides over 1.8 Gbps of total servicebandwidth.

In addition to support for high-speed Internet (HSI) services, CSPs need solutions that allow them to support a full complement of additional services, including IPTV and guest Wi-Fi. In response, the Calix solution supports differentiated quality of service (QoS) as well as isolation between the services. To ensure a seamless mobile streaming experience, the software used by the GigaSpire and GigaMesh has been enhanced to support both band steering and network-assisted node steering. Steering directs subscriber Wi-Fi devices to connect to the radio signal that results in the best user experience.

Calix leverages the latest standards for roaming and steering, including 802.11k, 802.11r and 802.11v. The combination of GigaSpire and GigaMesh satellites enables subscribers to receive Gigabit broadband data, IP video, and voice over (VoIP). Using the latest 802.11ax 5 GHz technology – incorporating 2x2 multi-user multiple-input and multiple-output (MU-MIMO) with beamforming – the BLAST u4m satellite allows CSPs to extend the access network inside the home and establish a strategic location for the delivery and control of broadband services.

Calix engineered the BLAST u4m for optimal whole-home coverage with simultaneous dual-band 2.4 GHz and 5 GHz operation and dynamic beamforming at 5 GHz. For maximum performance, the BLAST u4m supports high-power 2x2 MIMO spatial diversity at 2.4 GHz and 2x2 MU-MIMO at 5 GHz. The BLAST u4 and BLAST u4m solution easily delivers high definition (HD) and Ultra HD (UHD) video and data throughout a subscriber's home.

The Calix solution is scalable, allowing CSPs to initially deploy a GigaSpire and then add GigaMesh satellites to the end subscriber's home network as the need arises for additional coverage. One of the strengths of the Calix solution is that CSPs can leverage the instrumentation provided by the GigaSpires and GigaMesh satellites to identify when the end subscriber can benefit from an additional GigaMesh. This allows them to be proactive and upsell additional services and assets.

Market research projects that tens of billions of residential IoT devices will be deployed in the coming years. The GigaSpire and GigaMesh provides powerful Wi-Fi to support the growing IoT deployment. Service providers can now deploy the BLAST u4m with plug-and-play Wi-Fi IoT devices such as security cameras, sensors, and smart plugs.

## **EASY TO INSTALL, ACTIVATE AND MAINTAIN**

With the GigaMesh satellites, Calix has redefined how to install and activate residential services. When deployed with a wired connection it's as simple as plugging a Cat 5e/6 cable in between the GigaMesh RJ-45 port and the parent GigaSpire. The GigaMesh leverages its TR-069 interface to communicate its presence to the Calix Support Cloud, which adds the GigaMesh to the subscriber account. The system harmonizes the services on the GigaMesh. This removes all human error-prone touch points. When deployed with a wireless connection, the subscriber uses the Wi-Fi Protected Setup (WPS) button on both the GigaMesh and the GigaSpire to pair the mesh network. In addition, built-in signal strength indicator on the GigaMesh provides identification for the best placement location. Once this step is done, discovery, configuration and harmonization steps occur. The Calix Support Cloud's extensive troubleshooting capabilities, remote software downloads, and easy-to-use service activation features ensure that services are delivered and maintained without needless truck rolls and hardware upgrades. Employing the GigaSpire and GigaMesh satellites allows CSPs to reduce their operational expenses while effectively delivering an elevated Gigabit experience to their subscribers.

## **Key Attributes**

- Whole Home Coverage Wi-Fi Mesh Satellite
  - Layer 2 bridge and Layer 3 routing for High Speed Internet (HSI) data and IPTV video services
  - Self-Organizing Network (SON)
    - Auto configuration
    - Band and node steering
  - Increased network capacity
  - Bridge port assignment and data traffic pings
  - MAC filtering Wi-Fi
- Wireless:
  - 2.4 GHz and 5 GHz, simultaneous dual-band
  - 2.4GHz and 5 GHz 802.11ax (Wi-Fi 6) certified, 802.11a/n/ac compatible
  - 4x4 streams (2x2 @ 2.4 GHz and 2x2 @ 5 GHz)
  - WPA/WPA2/WPA3; WEP 64/128 bit encryption
  - PuF (Physical Unclonable Functions)

- 
- WPS push-button
  - 2x2 DL/UL MU-MIMO with beamforming
  - 1024 QAM; OFDMA; BSS Coloring
  - Support for 802.11k/r/v/s o
    - 11k Radio Resource Management
    - 11r Fast Roaming
    - 11v Wireless Network Management
  - Support 4-address WDS mode
  - Support 16 SSID Replication per band
  - 1.2 Gbps Radio Backhaul with GigaSpire
  - Channel Optimization DFS (only EU)
  - Wireless Backhaul Signal Strength
  - Wi-Fi Redundant Mesh:
    - Self Managed: self configuration, Air time fairness
    - Dynamic Mesh: load balancing, band/node steering; interference management
    - Self Healing; diagnostics; events
  - One Gigabit Ethernet (GE) interface – LAN or WAN:
    - Symmetrical 1 Gbps for residential IPTV and data services
    - Multi-rate 10/100/1000 BASE-T Ethernet, auto-negotiation
  - Wi-Fi Redundant Mesh:
    - Self Managed: self configuration, Air time Fairness
    - Dynamic Mesh: load balancing, band/node steering; interference management
  - USB port:
    - USB 2.0 - Type A host interface
  - Supports multiple data service profiles
  - IPTV, IGMPv2, future support of IGMPv3:
    - IGMP Snooping and Proxy
    - IGMP Fast Leaves
  - Gateway Management:
    - CSC (Calix Support Cloud)
    - TR-069
    - Local Home Gateway GUI, access provisionable
    - Remote WAN side GUI access
    - Default username/password
  - AC to 12 VDC power adapter

## ***Agency Listing***

**FCC WARNING:** These devices comply with Part 15 of the FCC Rules and Regulations. Operation is subject to the following conditions.

This device may not cause harmful interference, and, this device must withstand any interference received, including interference that may cause undesired operation.

The ONT has been tested and found to comply with the limits for a Class B digital device pursuant to Part 15 of the FCC Rules and Regulations. These limits are designed to provide reasonable protection against harmful interference when this equipment is operated in a commercial environment. This equipment generates, uses, and can radiate radio frequency energy and, if not installed and used in accordance with the instructions in this guide, may cause harmful interference to radio and television communications.



---

## Radiated Emissions

- This Class-B digital device complies with radiated emissions requirements as defined in Canadian ICES-003.

## Power Supply

**Note:** When using the standard power adapter, units will be inoperable after loss of main power.

- The unit must be powered by a listed power adapter or DC power source marked "LPS" (Limited Power Source) and rated output between 12 VDC, 375 mA minimum, 2 A minimum, T<sub>ma</sub> = 40° C minimum. If additional help is needed on implementing a power supply, please contact your local Calix service professional.

An external power supply is included with the following rating:

### BLAST u4

- Input voltage: 12 VDC (nominal)
- 10 VDC (min.), 15 VDC (max)
- External Power Adapter: 12 VDC, 2 A

### BLAST u4m

- Input voltage: 12 VDC (nominal)
- 10 VDC (min.), 15 VDC (max)
- External Power Adapter: 12 VDC, 1.5 A



**DANGER!** Using non-approved or incorrect power adapters can result in injury.

---

## Site Preparation

Before you install any GigaSpire BLAST device, you need to consider the routing of the power adapter cord and Ethernet cable(s) if used.

**Note:** It is critical that you maintain the proper airflow in and around the unit. GigaSpire BLAST devices are designed for surface mounting only. Do not install cabinetry or other building material around the outside of the unit.

### Power Cords

In order to complete the installation, a power cord is required:

- GigaSpire Connectorized Power and Signal Cable - A 2-pin barrel connector to the local AC power receptacle (Type A).

### Coaxial Cables

Note that Coaxial cable connections are to be internal connections only. Outdoor connections are not allowed.

## Before you Begin

Before starting the installation process, check that the following conditions are met:

- Ensure the site preparation steps are complete based on the model being installed.
- Ensure that all components are on-site or readily available to complete the installation.
- The customer is aware of your planned visit and will provide access to the inside of the home.

---

## **Introduction**

This document describes the installation of the following:

- GigaSpire BLAST u4
- GigaSpire Mesh BLAST u4m

The BLAST u4 and u4m are designed to be placed in a horizontal table-top configuration or can be wall mounted using the mounting holes molded into the back of the unit.

### **Powering Options**

- By attaching to any 110/220 VAC power outlet using the supplied 12 VDC wall transformer.

**Note:** For all models, the power cord configuration must be appropriate for use in the country where the device is being deployed.

**Note:** Only Calix provided and approved power cords or voltage adapters should be used to connect to this product(s).

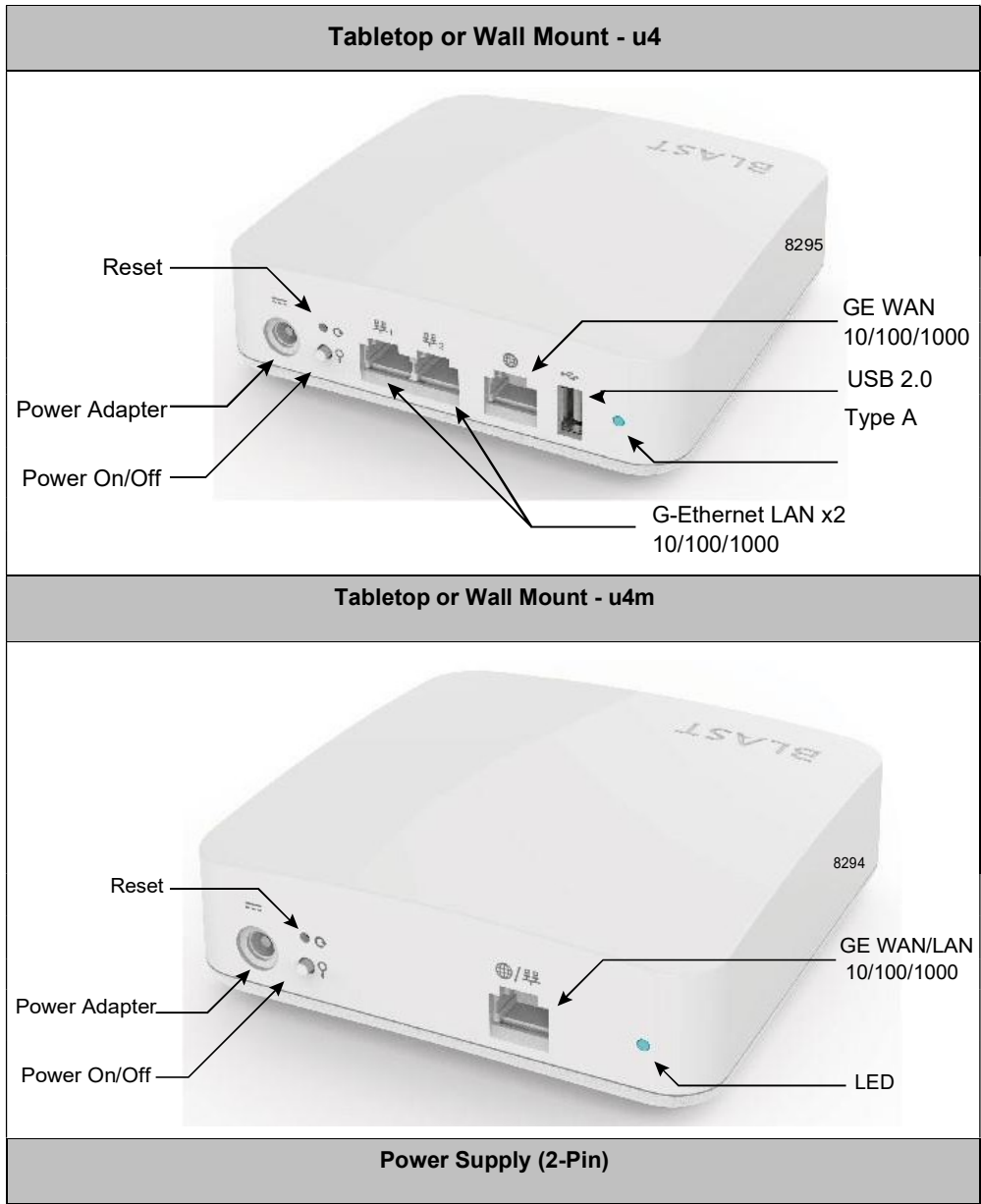



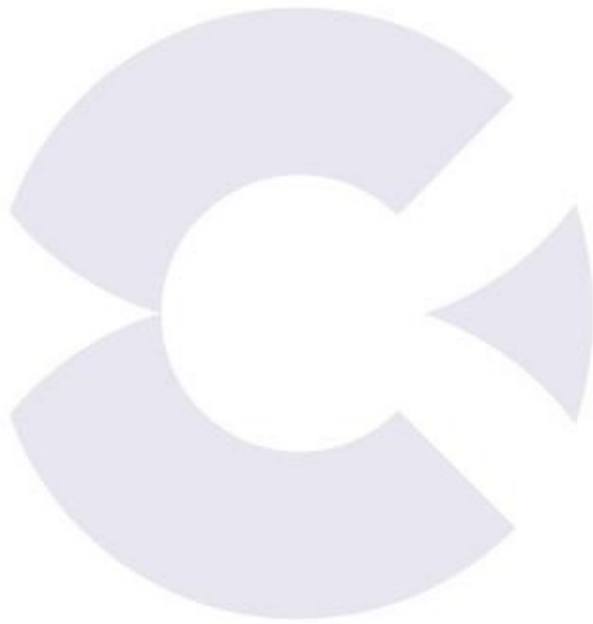

## Chapter 2

# Installation

## Installation Tips



**CAUTION!** Use of controls or adjustments or performance of procedures other than those specified here may result in hazardous radiation exposure.

---

Follow these tips when installing a GigaSpire device:

- For subscribers using data services, all data wiring inside the home must be CAT5e cable or better.
- Make sure subscriber connections are tightened properly.
- Check the contents of each box carefully as you receive them. Components may not be located where you might expect them due to certain items being tested immediately before shipment.

### About Wi-Fi Placement

Certain building materials are particularly effective at blocking Wi-Fi signals (see table below) and should be taken into consideration when locating the GigaSpire BLAST u4 or Mesh BLAST u4m. Line of sight is not necessary since MIMO technology takes advantage of reflections in the over-the-air path to carry additional data. However, Calix recommends that when possible, Calix GigaSpires should be placed in a centralized location within the home to yield the best possible results for Wi-Fi coverage.

Building Materials and Their Effect on Wi-Fi Signals	
Material	Wi-Fi Attenuation
Wood, Drywall, Particle Board, Tile	Low
Glass	Low
Water	Medium
Bricks, Cinder Block	Medium
Plaster, Stucco	High
Concrete	High
Tinted or Low-E Glass (metalized)	Very High
Metal	Very High

lower the attenuation, the better the performance.

## Installation Variables

Before installing the GigaSpire BLAST u4 or Mesh BLAST u4m, consider what additional services may be implemented. Various access points are available on the back of the unit which may or may not be used. Prior to determining the unit's final location, you need to account for the following variables:

- Optional: Where will the Ethernet cable be routed?
- What type of building material is used in this facility? Make sure you have the appropriate drills, drill bits and fasteners for routing Ethernet or power cables as they pass through walls and the like.

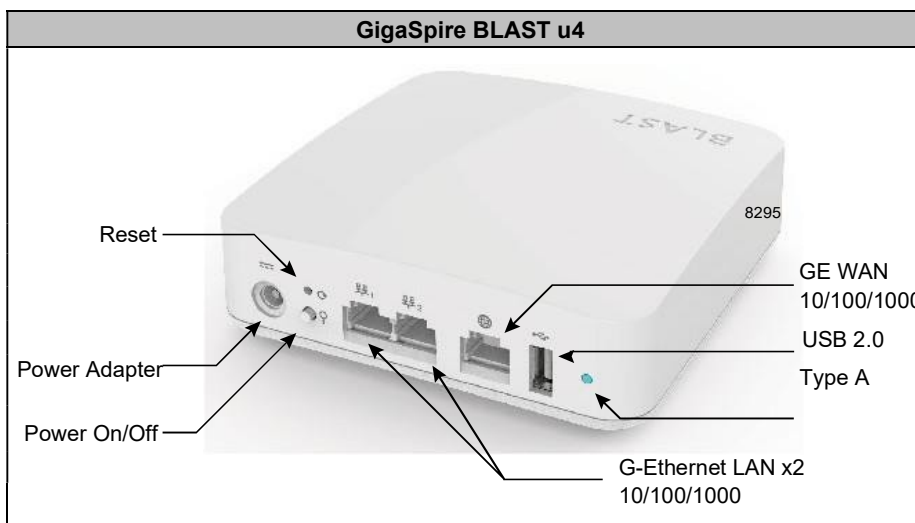



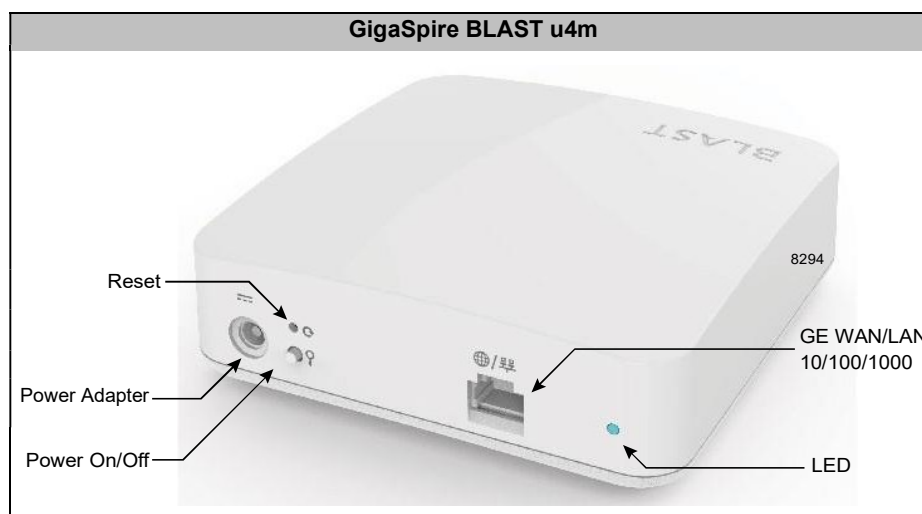

## ***Unpacking the GigaSpire u4/u4m***

Each GigaSpire BLAST u4 or u4m is shipped individually in its own carton and contains the following:

- (1) GigaSpire BLAST u4 or (1) GigaSpire Mesh BLAST u4m
- (1) Power Adapter interface cord (wall wart)
- (1) Safety and Regulatory Statements Guide
- (2) Product Identification Labels with Login Credentials

After opening the carton, remove the protective packaging, ensure all components above are present, and prepare for mounting the unit.

## Tabletop Mounting Dimensions

Dimensions are shown here for your reference.

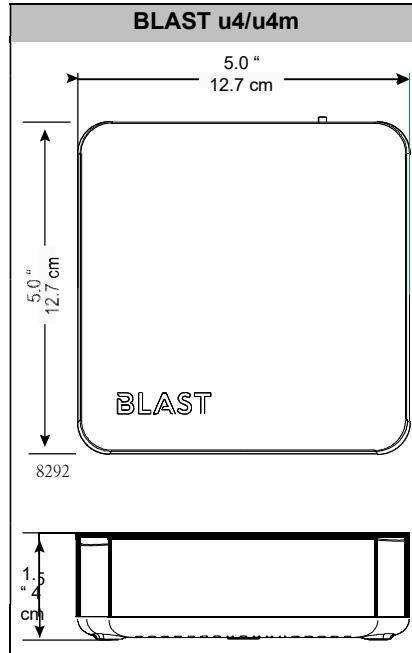

## Wall Mounting Dimensions

Dimensions for wall mounting of a GigaSpire BLAST u4 or Mesh BLAST u4m are included here for reference.

**Note:** There is no wall mount bracket necessary to mount these devices. The bottom chassis itself includes appropriate cut-outs and hanger posts to facilitate wall mounting.

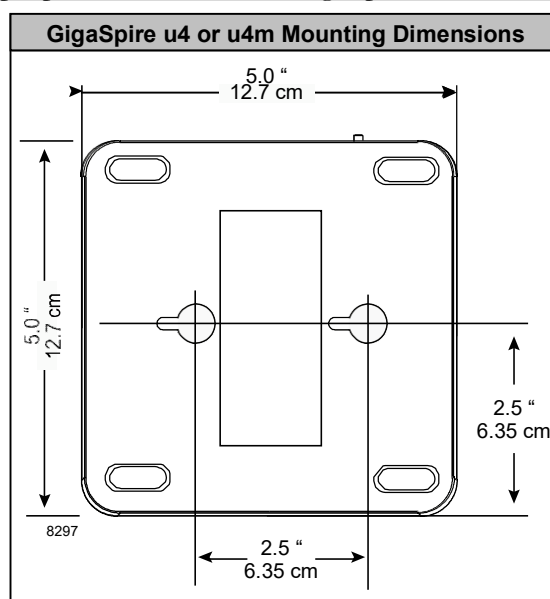

## Tabletop Mounting the u4/u4m

Any Calix GigaSpire BLAST u4 or u4m can be mounted flat on a tabletop. Four (4) rubberized feet are pre-installed on the bottom of the unit to provide a non-skid surface when placing the GigaSpire on a table or shelf.

Keep the following information in mind when considering tabletop mounting:

- Due to component placement inside the chassis, do not remove the rubber feet that are installed on the bottom of the unit. Locate the GigaSpire BLAST on the desktop in a location that is unlikely to be bumped or jostled.
- Make sure that the Ethernet cable(s) if used and power supply wiring attached to the GigaSpire are secured properly and out of harms way.

**Note:** Once the GigaSpire is connected and turned up, Wi-Fi network parameters are persisted in memory. For this reason, if power is lost to the GigaSpire, it will be re-discovered on the network automatically, without operator intervention.

## Wall Mounting the u4/u4m

The Calix GigaSpire BLAST u4 and the GigaSpire Mesh BLAST u4m can be wall mounted using. Keep the following information in mind when considering wall mounting:

- Locate the BLAST on the wall in a location that is unlikely to be bumped or jostled.
- Make sure that the Ethernet cable(s) (if used) and power supply wiring attached to the GigaSpire are secured properly and out of harms way.

**Note:** Once the GigaSpire is connected and turned up, Wi-Fi network parameters are persisted in memory. For this reason, if power is lost to the GigaSpire, it will be re-discovered on the network automatically, without operator intervention.

### To wall mount the GigaSpire BLAST u4 or u4m

1. Find a suitable location for attaching unit to the wall. Be mindful of the power source and Ethernet cable requirements when determining a mounting location.
2. Using the template included in the back of this guide, mark the two screw locations on the wall, making sure the device will remain level after mounting.

**Note:** If attaching to sheet rock or gypsum board, Calix recommends using a wall anchoring system to ensure the bracket is securely attached to the wall.

3. Drill holes in the wall and install appropriate wall anchors if required.
4. Thread the screws into the wall anchors and tighten leaving a gap of about 1/8" between the screw head and the and the back of the unit.

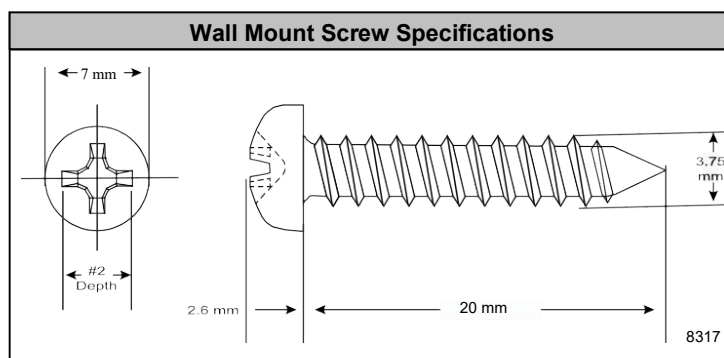

### Mounting Screws

The two mounting holes on the back of the unit are designed to accommodate the following screw type:

- larger than 7mm wide and less than 14mm wide
- Screw shaft < 3mm in diameter
- Screw length > 6mm

Depending on the material you are attaching to, use a screw of sufficient length and strength to support the GigaSpire BLAST once attached to the bracket. See below for specifications on what type of screw is recommended.

---

## ***Additional Mounting Considerations***

The options for mounting a GigaSpire BLAST system are many. From a best practices standpoint, keep the following in mind:

- Calix recommends mounting the BLAST as high as possible for Wi-Fi performance reasons. However, this deployment scenario still mandates that an AC power outlet is located within the power cord distance of the Wi-Fi source. If installing in a greenfield environment (initial installation), plan on placing the GigaSpire BLAST within 4 feet of the power supply. As an alternative, longer power cords are available to extend the distance between the BLAST and the power supply.
- Calix also recommends keeping cabling neat and well secured where ever possible. A tidy installation allows for increased safety and an overall neater appearance. Common tools used for this purpose include cable ties and velcro straps for routing cable out of the way. Also, custom made wall plates are often used where the majority of cabling is hidden behind a wall.

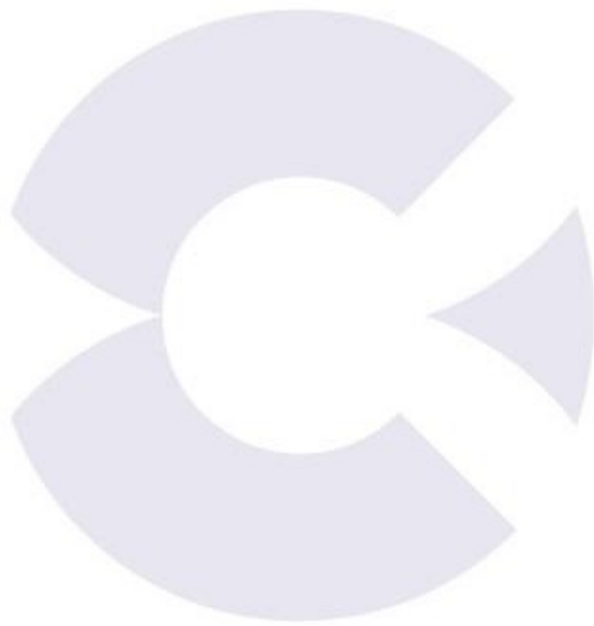



## Chapter 3

# Final Set-up and Testing

### BLAST u4/u4m Reset Behavior

Calix EDGE systems support a variety of system reset functions and provide multiple methods for invoking each of these functions, as described in this topic. Calix defines these functions and behaviors as follows:

- 1.** Basic reset (reboot): Restarts the router.
- 2.** Configuration reset: Resets the RG configuration settings (those visible to the subscriber/Admin user in the EWI, such as SSIDs, LAN IP scope, etc.) to defaults, but retains operator-configured management settings (those visible only to the Support user in the EWI, such as ACS URL and SPID).
- 3.** Factory reset: Resets the router (and any attached mesh satellites) to factory default settings. A factory reset also removes devices from network management systems, including Calix Support Cloud and the Smart Home Admin Dashboard, where applicable.

These reset functions can be used as troubleshooting and/or operations tools for reset/removal scenarios, whether the device is deployed as a Residential Gateway or as a subtended WAP or Satellite (GigaSpire BLAST or GigaMesh). Hardware-invoked resets behave differently depending on how long the reset button is pressed, as described below.

Function	Where Performed
Basic Reset <sup>1</sup>	Hardware: Press Reset button once for 1 second
	Software: EWI > Utilities > Reboot
Configuration Reset <sup>2</sup>	Hardware: Press and hold Reset button for 15+ seconds
	Software: EWI > Utilities > Restore Defaults
Factory Reset	Hardware: no option
	Software (for support user only): EWI > Support > Tools > Smart Activate > Factory Reset
<p><b>Note:</b> For operators with Calix Support Cloud (CSC), remote resets can be invoked as follows:</p> <p><sup>1</sup> System Tools &gt; Reboot (<a href="https://www.calix.com/content/calix/en/site-prod/library-html/software-products/cloud/nm/support/help/index.htm#88688.htm">https://www.calix.com/content/calix/en/site-prod/library-html/software-products/cloud/nm/support/help/index.htm#88688.htm</a>)</p> <p><sup>2</sup> System Tools &gt; Factory Reset (<a href="https://www.calix.com/content/calix/en/site-prod/library-html/software-products/cloud/nm/support/help/index.htm#88687.htm">https://www.calix.com/content/calix/en/site-prod/library-html/software-products/cloud/nm/support/help/index.htm#88687.htm</a>) (option actually performs just a configuration reset)</p>	

The table below provides additional notes for each Reset event:

BLAST Reset Behavior			
Reset Type	How Invoked	Expected Behavior	Notes
Basic Reset - Hardware	Press Reset button	<ul style="list-style-type: none"> <li>Router or satellite reboots</li> <li>RG configuration and subscriber's custom settings persist</li> </ul>	Pressing the Reset button performs a standard power cycle. All configuration information persists. Device goes offline for 2-3 minutes while it completes the reboot process.
Basic Reset - Software	EWI > Utilities > Reboot	<ul style="list-style-type: none"> <li>Router reboots</li> <li>RG configuration and subscriber's custom settings persist</li> </ul>	Subscriber (Admin user) has access to the EWI to invoke a soft reset. All configuration information persists. Device goes offline for 2-3 minutes while reboot process completes.
Configuration Reset - Hardware	Press and hold Reset button (10+ seconds)	<ul style="list-style-type: none"> <li>Router or satellite reboots</li> <li>RG configuration and subscriber's custom settings reset to defaults</li> <li>Service provider applied management settings persist</li> </ul>	Reset button must be pressed and held until LEDs flash (after about 10 seconds). Device goes offline while it completes the reboot process. Residential Gateway (RG) configuration settings include all subscriber- configurable information such as login credentials for Admin user, SSIDs, LAN IP scope, etc., all of which reset to defaults.
Configuration Reset - Software	EWI > Utilities > Restore Defaults	<ul style="list-style-type: none"> <li>Router reboots</li> <li>RG configuration and subscriber's custom settings reset to defaults</li> <li>Service provider applied management settings persist</li> </ul>	Subscriber (Admin user) has access to the EWI to invoke a configuration reset. Device goes offline while it completes the reboot process. Residential Gateway (RG) configuration settings include all subscriber- configurable information such as login credentials for Admin user, SSIDs, LAN IP scope, etc., all of which reset to defaults.
Factory Reset - Software	EWI > Support Menu > Tools > Smart Activate > Factory Reset	<ul style="list-style-type: none"> <li>Router reboots</li> <li>RG configuration settings reset to factory defaults</li> <li>Service provider applied management settings reset to factory defaults</li> </ul>	Function available only to operators via EWI Support user (not available to subscriber/Admin user). Service provider management settings include all information visible on the EWI Support tab, such as login credentials for Support user, TR-69 ACS URL and login credentials, SPID, etc., all of which reset to defaults.



## Powering the BLAST u4/u4m

The information below describes the powering of any GigaSpire BLAST.

### To power up the BLAST u4 or u4m

1. Locate the 12 VDC Power Adapter.
2. Attach one end (2-pin barrel connector) to the rear of the BLAST u4/u4m.
3. Plug the other end into any available 110/220 VAC wall outlet.
4. The GigaSpire BLAST begins its start-up sequence (Flashing blue LED).

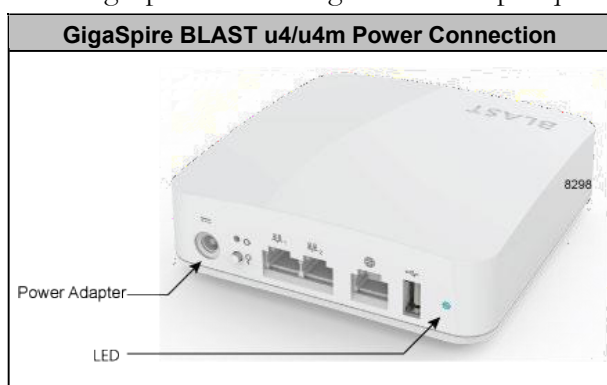

## Connecting to the Internet

The method by which the GigaSpire BLAST u4 or GigaSpire Mesh BLAST u4m is deployed will impact the internet connection. With power applied to the BLAST, perform the following steps based on the role the device plays in the network.

### Connecting to a residential gateway

If the unit is configured as a Residential Gateway, connect an Ethernet Cable to its WAN port from the WAN modem (ONU, cable modem, or DSL modem).

### Connecting as a Mesh point

If the unit is configured as a MESH point, connect an Ethernet cable from its WAN port to another GigaSpire or wirelessly connect the two devices.

### Additional Comments

- Once your GigaSpires LED turns BLUE, you are connected to the upstream WAN modem.
- At start-up, Wi-Fi radios are defaulted to on.
- To configure your GigaSpire BLAST device, connect an Ethernet cable between your PC and the LAN port of your unit and enter the default IP Address of the device (192.168.1.1) into your browser.
- Wi-Fi radios can be configured using the default settings:
  - SSID: Printed on the product label in the gift box. (CXNKxxxxxxx)
  - Number of radios: 2 (2.4 GHz and 5 GHz)
  - Wi-Fi Protocol supported: 802.11a/b/n/g/ac/ax
  - Credentials: Login and password printed on the product label in the giftbox.

## LED States - Power Off & Boot-up

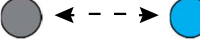
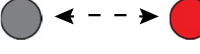

**Note:** For all LED sequences, the BLAST u4 and the Mesh BLAST u4m incorporate a single LED located on the interface side of the unit.

Power Off and Boot-up		
Description	Colors	Indication
<b>OFF</b> <ul style="list-style-type: none"> <li>Power is Off</li> <li>The unit has not been turned on</li> </ul> <i>or</i> <ul style="list-style-type: none"> <li>There is no power to the unit</li> </ul> <i>or</i> <ul style="list-style-type: none"> <li>Any auxillary battery has been discharged and can no longer power the unit.</li> </ul>	Off	
<b>Booting Up, SW Upgrade in Process</b> <ul style="list-style-type: none"> <li>Unit is in the process of booting up or services/software is being upgraded</li> <li>Flashing ever 1 second assuming software can control the LED</li> </ul>	Off & Cyan Cycles @ 1000 msec	
<ul style="list-style-type: none"> <li><b>Boot-up Failure</b></li> <li>Unit boot-up has failed (assuming software can control the LED).</li> </ul>	Off & Red Cycles @ 800 msec	

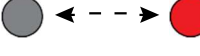
## LED States - BLAST LED Status

BLAST LED Status		
Description	Colors	Indication
<b>Connect to Internet</b> <ul style="list-style-type: none"> <li>Unit has successfully booted up, local services are up, and connected to the Internet</li> </ul>	CYAN Continuous	
<b>Service Failure - No Internet Connection</b> <ul style="list-style-type: none"> <li>Unit is in the process of booting up or services/software is being upgraded</li> <li>Flashing ever 1 second assuming software can control the LED</li> </ul>	Off & Red Cycles @ 1600 msec	

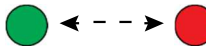
## LED States - Samsung Smart Things

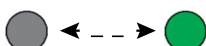
Samsung Smart Things		
Description	Colors	Indication
<b>ST Hub Ready for Setup</b> <ul style="list-style-type: none"> <li>Red &amp; Green Flashing</li> </ul>	LED green and Red cycles at 500 msec. Once set-up, reverts to gateway previous status If set-up is not successful, consult Error states under Smart Things	
<b>Set-up Error</b> <ul style="list-style-type: none"> <li>Flashing Red</li> </ul>	If Set-up is not successful, cycle red @ 500 msec, continue flash for 30 secs, then revert to the gateway previous status	
<b>Searching for Sensor</b> Flashing Green	During search for sensor, LED cycles green @ 500 msec. If sensor is found, the LED reverts to gateway previous status. If the sensor is not found, the blinking continues for 60 secs, then reverts to gateway previous status	

## LED States - Mesh Mode

Mesh BLAST u4m with BLAST u4		
Description	Colors	Indication
<b>GS202xE Mesh Satellite</b> (Backhaul pairing cycle can be started by WPS button press [3+ second press] or equivalent EWI or smartphone app activation)	For backhaul pairing press WPS for at least 3 seconds	N/A
<b>Booting Up or SW Upgrade in Process</b> <ul style="list-style-type: none"> <li>Unit is in the process of being boot up or service/software is being upgraded</li> <li>Flashing every 1 second on cyan color - assuming SW can control the LEDs.</li> </ul>	Off and Cyan (1000 msec)	
<b>Boot-up Failure</b> <ul style="list-style-type: none"> <li>Unit boot-up failed (if SW can control the LEDs)</li> </ul>	Off and Red (800 msec)	
<b>WPS Pressed, Pairing Attempt has Begun</b> <ul style="list-style-type: none"> <li>For Satellite/Mesh mode, upon pressing the WPS a single time 3+ seconds, WPS is enabled.</li> <li>The LED bar begins to flash 0.5 second green/off and continues to do so for up to 120seconds.</li> <li>If the Gateway has also initialized WPS during this time, the Satellite can be paired to the Gateway Wi-Fi radios (5.0 GHz band) thereby creating an association with the GatewaySSID.</li> </ul>	Green and Off (500 msec)	
Display Signal Strength (Positioning Strength) <b>Display strength after any of the following conditions (IP address obtained):</b> <ol style="list-style-type: none"> <li>Successful pairing completed</li> <li>Re-start completed (and previous pairing with Gateway restored)</li> <li>Re-association of link with the Gateway after lost link (e.g., Gateway was powered down then restored)</li> </ol> <ul style="list-style-type: none"> <li>If the pairing is successful, following will be the behavior of the WPS/Strength LED:</li> <li>If the Satellite is too close from Gateway but still connected, LED will light up fast blinking green (250msec).</li> <li>* If the Satellite is too far from Gateway but still connected, LED will light up slow blinking green (1000 msec).</li> <li>* When the Satellite is at an ideal location from Gateway the LED will light up steady green.</li> <li>* After 60 seconds, the light bar begins to reflect Gateway status (not shown in the illustration below). For example, cyan for connected to the Internet</li> </ul>	Gray and Green	Too Close: Fast Blink (250 msec)  Too Far: Slow Blink (1000 msec)  Ideal: Steady State 
<b>Gateway Not Found</b> <ul style="list-style-type: none"> <li>If no device is found after the initial 120 second time-out, the WPS/Strength LED bar shifts from the blinking Green to solid Red.</li> <li>LED bar remains red for another 60 seconds, then revert to the No Internet failure status.</li> <li>If pairing is accomplished, LED bar will change to reflect Gateway status.</li> </ul>	Solid Red	

Proprietary Information: Not for use or disclosure except by written agreement with Calix.

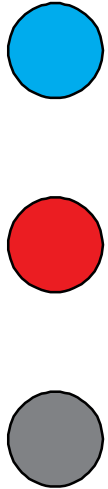
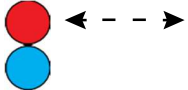
<p><b>After pairing, follow the Gateway Status</b></p> <ul style="list-style-type: none"> <li>• After the pairing is complete (60 seconds after the signal strength has been displayed), the light bar indication shall follow the Gateway status as described on the Light Bar tab in this spreadsheet.</li> <li>•</li> <li>• If the mesh is connected via Ethernet connection, if boot up successfully, the light bar indication shall follow the Gateway status as described on the Light Bar tab in this spreadsheet.</li> </ul>	<p>After 60 seconds, Cyan or Red, or Off</p>	
<p><b>Lost Control plane but data plane is still connected</b></p> <p>Regardless of what stage the mesh unit is in. If the control plane is lost but the data plane is still in connection. Then flash the LED to red for 15 seconds, after that return the LED to cyan</p>	<p>Flash LED to red for 15 seconds, then revert to Cyan</p>	

## Wall Mount Template

Inside the giftbox of the BLAST u4 or u4m, a printed wall mount template is included. This template is scaled to size and should be used when marking the hole locations for the wall mount option. The figure below is a representative example of the template but should not be used as it is not scaled appropriately.

For additional information, refer to *Wall Mounting the u4/u4m* (on page [28](#)) located in the Installation chapter of this guide.

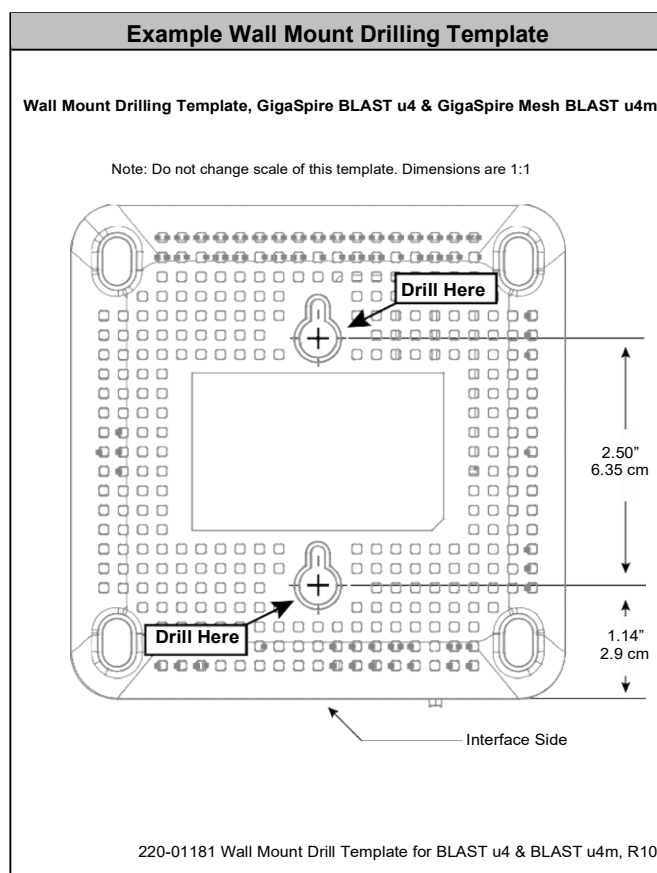

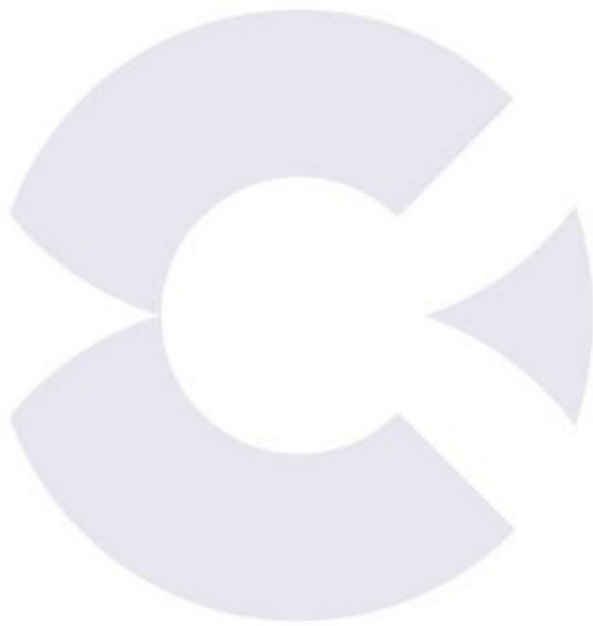



## Calix Safety and Regulatory Statements - GigaSpire BLAST u4/u4m

**NOTE:** This *Safety and Regulatory Statements Guide* applies to all GigaSpire devices that may or may not include a Wi-Fi radio. Disregard any statements made here if the feature or function is not present on any particular model.

### Before you Begin

#### IMPORTANT SAFETY INSTRUCTIONS

When using your equipment, basic safety precautions should always be followed to reduce the risk of fire, electric shock, and injury to persons, including the following:

- Read all the instructions listed here and/or in the user manual before you operate this device. Give attention to all safety precautions. Retain the instructions for future reference.
- Always use caution when handling live electrical connections.
- Do not install electrical equipment in wet or damp conditions.
- Ensure that the power source for the system is adequately rated to assure safe operation and provides current overload protection.
- Do not allow anything to rest on the power cable, and do not place this product where people will stand or walk on the power cable.
- This unit must only be used with the certified power adapter model inside the package, which complies with the requirement of a limited power source.
- Installation of this device must be in accordance with national wiring codes and conform to local regulations and electrical codes.
- Do not use any accessories other than those approved by the manufacturer or your service provider. Use of non-original or non-approved accessories may result in loss of performance, damage to the product, fire, electric shock or injury, and may violate regulations. The warranty does not cover product failures that have been caused by use of non-original or non-approved accessories.
- It is recommended that the customer install an AC surge protector in the AC outlet to which this device is connected. This is to avoid damaging the device by local lightning strikes and other electrical surges.
- The minimum distance between the user and/or any bystander and the radiating structure of the transmitter varies based on the country where it is deployed. For US deployments, 27 cm is the minimum distance while Canada requires a minimum of 33 cm.
- The pluggable external power supply provided with the unit should be mounted indoors. If other power supplies are employed, they should be LISTED ITE with a Limited Power Source (LPS) output or LISTED with a National Electric Code (NEC) Class 2 output.
- All installation methods shall be in accordance with national and local regulations and practices. The wiring method should include the use of Listed wire/cable acceptable for the application per the National Code, and should be one that an Authority Having Jurisdiction (AHJ) can approve per the Code.
- For US products, no wiring to the product should be exposed in lengths beyond 140 feet, as the circuits should avoid exposure to accidental contact with lightning and power conductors in accordance with NEC Article 725-57 (NEC 2005). The installer should also consider Articles 210, 240, 250, 770, and 810 of the NEC.

### Federal Communications Commission (FCC)

#### INTERFERENCE STATEMENT

This device complies with Part 15 of the FCC Rules. Operation is subject to the following two conditions:

- (1) This device may not cause harmful interference, and
- (2) This device must accept any interference received, including interference that may cause undesired operation.

This equipment has been tested and found to comply with the limits for a Class B digital device, pursuant to Part 15 of the FCC Rules. These limits are designed to provide reasonable protection against harmful interference in a residential installation. This equipment generates, uses and can radiate radio frequency energy and, if not installed and used in accordance with the instructions, may cause harmful interference to radio communications. However, there is no guarantee that interference will not occur in a particular installation. If this equipment does cause harmful interference to radio or television reception, which can be determined by turning the equipment on and on, the user is encouraged to try to correct the interference by one of the following measures:

- Reorient or relocate the receiving antenna.
- Increase the separation between the equipment and receiver.
- Connect the equipment into an outlet on a circuit different from that to which the receiver is connected.
- Consult the dealer or an experienced technician for help.

**CAUTION:** Any changes or modifications not expressly approved by the party responsible for compliance could void the user's authority to operate this equipment.

**CAUTION:** This device and its antenna(s) must not be co-located or operating in conjunction with any other antenna or transmitter except in accordance with FCC multi-transmitter product procedures.

#### ADDITIONAL CONSIDERATIONS

The country code selection is for non-US models only and is not available on any US models. Per FCC regulations, all Wi-Fi products marketed in the US must be fixed to US operational channels only.

#### RF FREQUENCY REQUIREMENTS

This device is for indoor use only when using all channels in the 5.150 GHz - 5.250 GHz and 5.725 - 5.850 GHz frequency range.

#### FCC RADIATION EXPOSURE STATEMENT

This equipment complies with FCC radiation exposure limits set forth for an uncontrolled environment. This equipment should be installed and operated with a minimum distance of 27cm between the radiator & your body.

## Industry Canada Requirements- English

The manufacturer declares that this product is in conformity with the requirements and other relevant provisions of the following Canadian standards:

- CAN ICES-3 (B)/NMB-3(B)
- This device complies with ISSED's licence-exempt RSS standards. Operation is subject to the following two conditions:
  - (1) This device may not cause interference, and
  - (2) This device must accept any interference, including interference that may cause undesired operation of the device.

### CAUTION:

- (i) The device for operation in the band 5150-5250 MHz is only for indoor use to reduce the potential for harmful interference to co-channel mobile satellite systems;
- (ii) The maximum antenna gain permitted for devices in the band 5725-5825 MHz shall comply with the e.i.r.p. limits specified for non-point-to-point operation as appropriate.

### RADIATION EXPOSURE STATEMENT

This equipment complies with ISSED radiation exposure limits set forth for an uncontrolled environment. This equipment should be installed and operated with a minimum distance of 33cm between the radiator & your body.

## Industrie Canada Exigences- français

Le présent appareil est conforme aux CNR d'ISED applicables aux appareils radio exempts de licence. L'exploitation est autorisée aux deux conditions suivantes : (1) le dispositif ne doit pas produire de brouillage préjudiciable, et (2) ce dispositif doit accepter tout brouillage reçu, y compris un brouillage susceptible de provoquer un fonctionnement indésirable.

- CAN-ICES-3 (B)/NMB-3(B)
- Le présent appareil est conforme aux CNR d'Industrie Canada applicables aux appareils radio exempts de licence. L'exploitation est autorisée aux deux conditions suivantes :
  - (1) L'appareil ne doit pas produire de brouillage, et
  - (2) L'utilisateur de l'appareil doit accepter tout brouillage radioélectrique subi, même si le brouillage est susceptible d'en compromettre le fonctionnement.

### AVERTISSEMENT

- (i) Les dispositifs fonctionnant dans la bande 5150-5250 MHz sont réservés uniquement pour une utilisation à l'intérieur afin de réduire les risques de brouillage préjudiciable aux systèmes de satellites mobiles utilisant les mêmes canaux;
- (ii) Le gain maximal d'antenne permis (pour les dispositifs utilisant la bande 5725-5825 MHz) doit se conformer à la limite de p.i.r.e. spécifiée pour l'exploitation et non point à point, selon le cas.

### DECLARATION D'EXPOSITION AUX RADIATIONS

Cet équipement est conforme aux limites d'exposition aux rayonnements ISSED établies pour un environnement non contrôlé. Cet équipement doit être installé et utilisé avec un minimum de 33 cm de distance entre la source de rayonnement et votre corps.

## European Union

### DISPOSING OF AND RECYCLING YOUR PRODUCT

WEEE Directive: Requirement according to WEEE directive 2012/19/EU

Disposal of old electrical and electronic equipment (Applicable in the European countries with separate collection systems).



This symbol on the product indicates that this product shall not be treated as household waste. Instead it shall be handed over to the applicable collection point for the recycling of electrical and electronic equipment. By ensuring this product is disposed of correctly, you will prevent potential negative consequences for the environment and human health, which could otherwise be caused by inappropriate waste handling of this product. The recycling of materials will help to conserve natural resources. Calix offers take-back and recycling services for products in many locations around the world. Customers are advised to contact the local Calix representative for further information.

### CALIX, INC. AND THE ENVIRONMENT

At Calix Inc., we understand and are committed to reducing any impact our operations and products may have on the environment. To minimize this impact, Calix Inc. designs and builds its products to be as environmentally friendly as possible, by using recyclable, low toxic materials in both products and packaging.

### ROHS COMPLIANCE

This equipment meets the requirements detailed in the European RoHS Directive 2011/65/EU.

## For Radio Equipment Only



You must set the correct country code with the set WLAN country-code command to avoid violating local radio spectrum laws. This command sets the selectable channel range and transmit power level so that a WLAN connection can be established. For more information about country codes, see the hardware guide for your device.



This device complies with the essential requirements of the Radio Equipment directive: 2014 / 53 / EU. The following test methods have been applied to prove presumption of conformity with the essential requirements of the Radio Equipment directive: 2014 / 53 / EU: EN 300 328 (2.4 GHz), EN 301 893 (5 GHz) EN 62311:2008, EN 50385, EN 301489-1, EN 301489-17, IEC 62368-1.

FREQUENCIES	MAX POWER	INDOOR/OUTDOOR
2400-2483.5	100 mW	Indoor
5150-5350	200 mW	Indoor
5470-5725	1000 mW	Indoor

#### RADIATION EXPOSURE STATEMENT

The minimum distance between the user and/or any bystander and the radiating structure of the transmitter is 27 cm for US deployments and 33 cm for Canadian deployments..

NOTICE OF WIRELESS RADIO LAN USAGE IN THE EUROPEAN COMMUNITY		
BE	BG	CZ
DK	DE	EE
IE	EL	ES
FR	HR	IT
CY	LV	LT
LU	HU	MT
NL	AT	PL
PT	RO	SE
SK	FI	SI
UK	LI	IS
NO	TR	CH

This device is restricted to **indoor use** when operated in the European Community using channels in the 5.15-5.35 GHz band to reduce the potential for interference.  
 This device is a 2.4 GHz wideband transmission system (transceiver), intended for use in all EU member states and EFTA countries, except in France where restrictive use applies. This device may not be used for setting up outdoor radio links in France and in some areas, the RF output power may be limited to 10 mW EIRP in the frequency range of 2454–2483.5 MHz. For detailed information, the end-user should contact the national spectrum authority in France.  
 This equipment may be operated in AL, AD, BE, BG, DK, DE, FI, FR, GR, GW, IS, IT, HR, LI, LU, MT, MK, MD, MC, NL, NO, AT, OL, PT, RO, SM, SE, RS, SK, ES, CI, HU, CY

#### Usage Notes

- To remain in conformance with European National spectrum usage regulations, frequency and channel limitations will be applied on the products per the country where the equipment is deployed.
- Access points will support DFS (Dynamic Frequency Selection) and TPC (Transmit Power Control) functionality as required when operating in 5 GHz within the EU.

#### 5 GHz Wireless Frequency and Channel Operation in EEC Countries

The table below provides a list of allowable frequency ranges and channels in various EEC countries.

Allowable 802.11a Frequencies and Channels	Countries
5.15-5.25 GHz (Channels 36, 40, 44, 48)	Liechtenstein
5.15-5.25 GHz and 5.725-5.875 GHz (Channels 36, 40, 44, 48)	Austria
5.15-5.35 GHz (Channels 36, 40, 44, 48, 52, 56, 60, 64)	France
5.15-5.35 and 5.47-5.725 GHz (Channels 36, 40, 44, 48, 52, 56, 60, 64, 100, 104, 108, 112, 116, 120, 124, 128, 132, 136, 140)	Denmark, Germany, Iceland, Finland, Netherlands, Norway, Poland, Sweden, Slovenia, Luxembourg, U.K., Ireland, Slovak, Switzerland, Hungary, Italy
5.15-5.35 GHz and 5.725-5.875 GHz (Channels 36, 40, 44, 48, 52, 56, 60, 64)	Czech Republic

#### Declaration of Conformity

Language	Declaration of Conformity
Български [Bulgarian]	С настоящото Calix Inc. Това декларира тази Wireless Broadband Терминал за достъп е в съответствие с Директива 2014/53 / ЕС. Пълният текст на ЕС декларацията за съответствие е достъпна онлайн от сайта на декларациите на Calix ( <a href="https://www.calix.com/declarations">https://www.calix.com/declarations</a> ).
hrvatski [Croatian]	OÖvime Calix Inc. To izjavljuje ovaj bežični širokopolasni pristup terminala u skladu s Direktivom 2014/53 / EU. Puni tekst izjave o sukladnosti za EU je dostupan online od kalix web deklaracije ( <a href="https://www.calix.com/declarations">https://www.calix.com/declarations</a> ).
English	Hereby, Calix Inc. declares that this Broadband wireless Access Terminal is in compliance with Directive 2014/53/EU. The full text of the EU declaration of conformity is available online from the Calix Declarations site ( <a href="https://www.calix.com/declarations">https://www.calix.com/declarations</a> ).
česky [Czech]	Tím Calix Inc. která deklaruje toto Wireless Broadband Access Terminal je v souladu se směrnici 2014/53 / EU. Úplné znění EU prohlášení o shodě je k dispozici online na webové stránce prohlášení kalichu ( <a href="https://www.calix.com/declarations">https://www.calix.com/declarations</a> ).
Deutsch [German]	Hiermit Calix Inc. Das erklärt der Wireless Broadband Access Terminal in Übereinstimmung mit der Richtlinie 2014/53 / EU. Der vollständige Wortlaut der EU-Konformitätserklärung wird online von den Calix Website Erklärungen zur Verfügung ( <a href="https://www.calix.com/declarations">https://www.calix.com/declarations</a> ).
Eesti [Estonian]	Käesolevaga Calix Inc. See kinnitab seda traadita lairühenduse Terminali kooskõlas direktiivi 2014/53 / EL. Tärvikteksti EU vastavusdeklaratsioon on saadaval võrgus Calix veebilehel deklaratsioonid ( <a href="https://www.calix.com/declarations">https://www.calix.com/declarations</a> ).
español [Spanish]	Por la presente, Calix Inc. Que declara esta Terminal de banda ancha de acceso inalámbrico está en conformidad con la Directiva 2014/53 / UE. El texto completo de la declaración de conformidad de la UE está disponible en línea desde el sitio web Declaraciones de Calix ( <a href="https://www.calix.com/declarations">https://www.calix.com/declarations</a> ).

Language	Declaration of Conformity
Ελληνική [Greek]	Δεi του παρόντος, Calix Inc. Αυτό δηλώνει αυτό το Wireless Terminal Ευρωπαϊκή πρόσβαση είναι σε συμμόρφωση με την οδηγία 2014/53 / ΕΕ. Το πλήρες κείμενο της δήλωσης συμμόρφωσης ΕΕ είναι διαθέσιμο στο διαδικτυακό από την ιστοσελίδα Calix Δηλώσεις ( <a href="https://www.calix.com/declarations">https://www.calix.com/declarations</a> ).
français [French]	Par la présente, Calix Inc. Cet accès qui déclare haut débit sans fil terminal est conforme à la directive 2014/53 / UE. Le texte intégral de la déclaration de conformité C'est disponible en ligne à partir des déclarations de site Calix ( <a href="https://www.calix.com/declarations">https://www.calix.com/declarations</a> ).
Italiano [Italian]	Con la presente, Calix Inc. Che dichiara questo terminale di accesso wireless a banda larga è conforme alla Direttiva 2014/53 / UE. Il testo integrale della dichiarazione di conformità UE è disponibile online dal sito Dichiarazioni Calix ( <a href="https://www.calix.com/declarations">https://www.calix.com/declarations</a> ).
Latvijas [Latvian]	Ar šo, Calix Inc. Tas paziņo, šis bezvadu platjoslas piekļuves termināls atbilst Direktīvas 2014/53 / ES. Pilns teksts ES atbilstības deklarācijas ir pieejama tiešsaistē no Calix tīmekļa deklarācijas ( <a href="https://www.calix.com/declarations">https://www.calix.com/declarations</a> ).
Lietuvos [Lithuanian]	Šiuo dokumentu Calix Inc Tai deklaruoja tai bevielės plačiajuosybės priegios terminalas atitinka Direktyvos 2014/53 / ES. Visą tekstą ES atitikties deklaraciją galima rasti internete nuo CALIX svetainės deklaracijos ( <a href="https://www.calix.com/declarations">https://www.calix.com/declarations</a> ).
Magyar [Hungarian]	Ezáltal Calix Inc. Hogy kijelenti azt Wireless Broadband Access Terminal irányelvnek megfelelelően 2014/53 / EU. A teljes szöveg az EU-megfelelésegi nyilatkozat elérhető online az Calix honlapján Nyilatkozatok ( <a href="https://www.calix.com/declarations">https://www.calix.com/declarations</a> ).
Polski [Polish]	Niniejszym, Calix Inc. Deklaruje, że ten Szerokopasmowy dostep bezprzewodowy terminal jest zgodny z dyrektywą 2014/53 / UE. Pełny tekst deklaracji zgodności UE jest dostepna on-line ze strony internetowej calix deklaracji ( <a href="https://www.calix.com/declarations">https://www.calix.com/declarations</a> ).
português [Portuguese]	Por este meio, Calix Inc. Que declara esta Terminal de Acesso de Banda Larga sem fios está em conformidade com a Directiva 2014/53 / UE. O texto completo da declaração UE de conformidade está disponível online a partir de declarações do Web site da Calix ( <a href="https://www.calix.com/declarations">https://www.calix.com/declarations</a> ).
român[Romanian]	Prin prezenta, Calix Inc poate declara que acces de bandă largă fără fir Terminal este în conformitate cu Directiva 2014/53 / UE. Textul integral al declarației de conformitate UE este disponibilă online din calix declarațiile site-ul ( <a href="https://www.calix.com/declarations">https://www.calix.com/declarations</a> ).
slovenščina[Slovenian]	S tem lahko calix Inc. razglasi, da širokopasovnega brezžičnega dostopa Terminal je v skladu z Direktivo 2014/53 / EU. Celotno besedilo izjave EU o skladnosti je na voljo na spletni strani izjavami calix ( <a href="https://www.calix.com/declarations">https://www.calix.com/declarations</a> ).
slovenský [Slovak]	Týmto Calix Inc. môže vyhlásiť tento que Broadband Wireless Access Terminal je v súlade so smernicou 2014/53 / EU. Úplné znenie vyhlásenia o zhode EU je k dispozícii online na webovej stránke vyhlásenie kalichu ( <a href="https://www.calix.com/declarations">https://www.calix.com/declarations</a> ).

#### For Non-Radio Equipment Only

##### European Community Declaration of Conformity

This device complies with the essential requirements of the Electromagnetic Compatibility (EMCD) DIRECTIVE: 2014 / 30 / EU, and Low Voltage (LVD) DIRECTIVE 2014/35/EU.

The following test methods have been applied to prove presumption of conformity with the essential requirements of the **EMCD and LVD**: EN 55032, EN 55024, EN 61000-3-2, EN 61000-3-3, EN 62368-1.