

Site: AC1	Time: 2014/07/18 - 15:33
Limit: FCC_Part15.209_RE(3m)	Engineer: Roy Cheng
Probe: BBHA9120D_1-18GHz	Polarity: Horizontal
EUT: WIFI dual band 4 GE LAN GPON HGU	Power: AC 120V/60Hz
Test Mode: Transmit by 802.11ac-VHT40 at channel 5510MHz Ant 0+1+2+3	

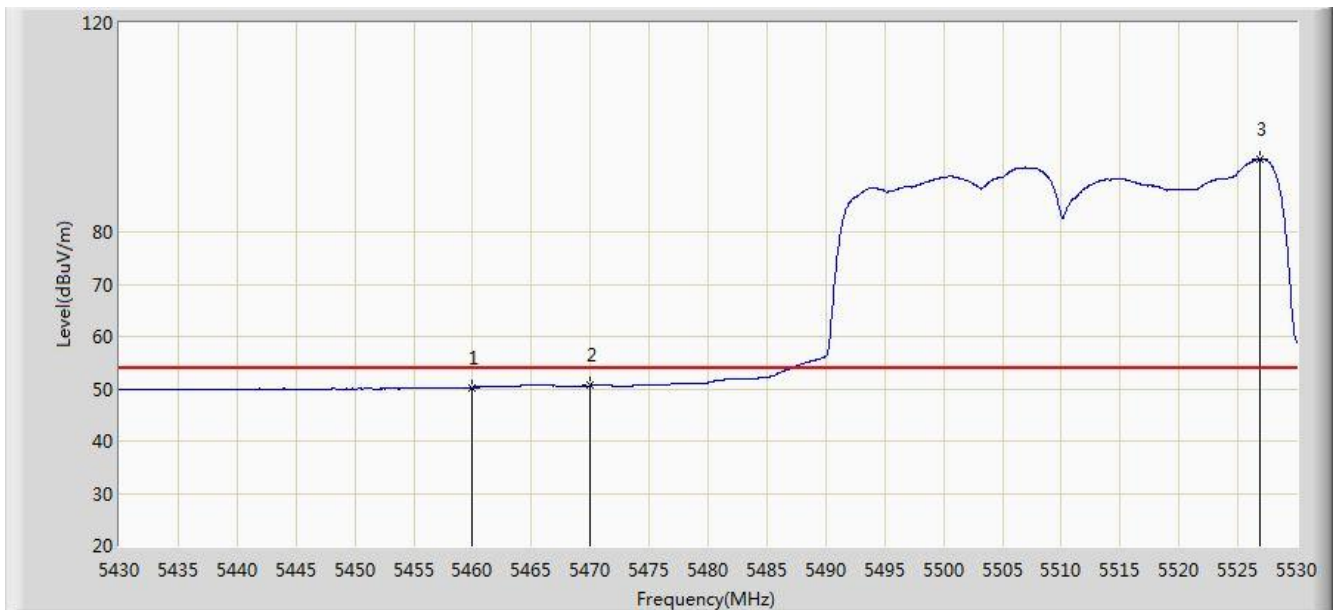

No	Flag	Mark	Frequency (MHz)	Measure Level (dBuV/m)	Reading Level (dBuV)	Over Limit (dB)	Limit (dBuV/m)	Factor (dB)	Type
1			5460.000	50.254	13.444	-3.746	54.000	36.810	AV
2			5470.000	50.589	13.764	-17.611	68.200	36.825	AV
3		*	5526.850	93.898	56.972	N/A	N/A	36.926	AV

Note: Measure Level (dB $\mu$ V/m) = Reading Level (dB $\mu$ V) + Factor (dB)

Factor (dB) = Cable Loss (dB) + Antenna Factor (dB/m).

Site: AC1	Time: 2014/07/18 - 15:37
Limit: FCC_Part15.209_RE(3m)	Engineer: Roy Cheng
Probe: BBHA9120D_1-18GHz	Polarity: Vertical
EUT: WIFI dual band 4 GE LAN GPON HGU	Power: AC 120V/60Hz
Test Mode: Transmit by 802.11ac-VHT40 at channel 5510MHz Ant 0+1+2+3	

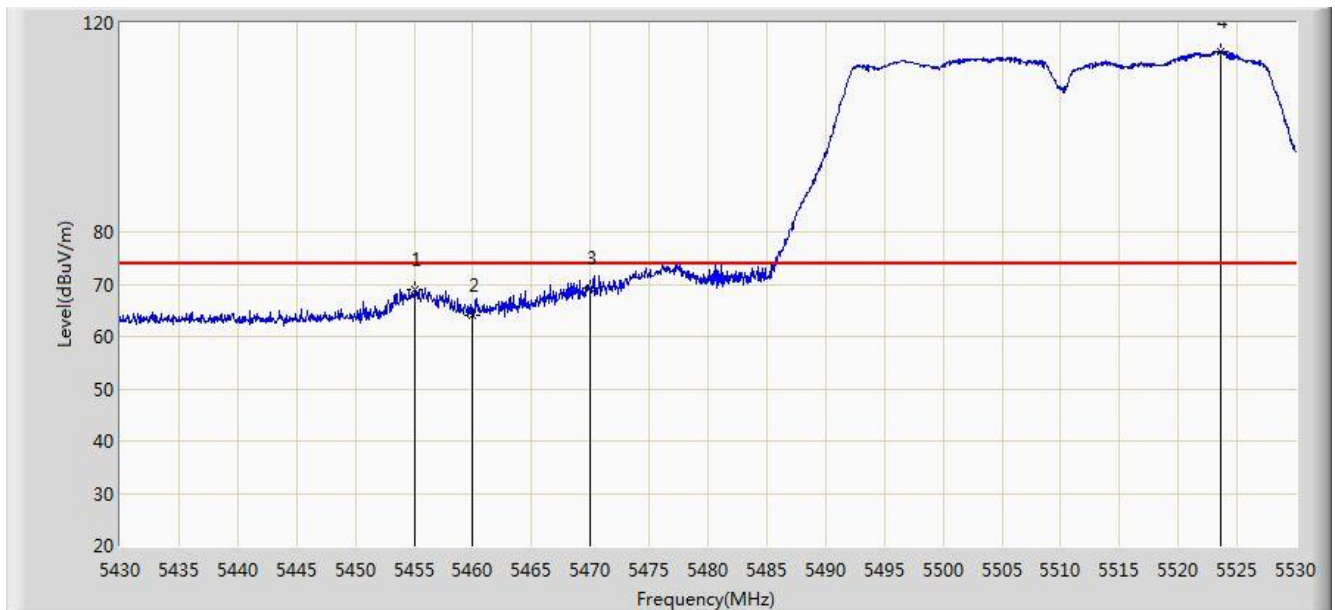

No	Flag	Mark	Frequency (MHz)	Measure Level (dBuV/m)	Reading Level (dBuV)	Over Limit (dB)	Limit (dBuV/m)	Factor (dB)	Type
1			5455.050	69.085	32.283	-4.915	74.000	36.802	PK
2			5460.000	64.123	27.313	-9.877	74.000	36.810	PK
3			5470.000	69.336	32.511	-18.864	88.200	36.825	PK
4		*	5523.550	114.495	77.572	N/A	N/A	36.923	PK

Note: Measure Level (dB $\mu$ V/m) = Reading Level (dB $\mu$ V) + Factor (dB)

Factor (dB) = Cable Loss (dB) + Antenna Factor (dB/m).

Site: AC1	Time: 2014/07/18 - 15:38
Limit: FCC_Part15.209_RE(3m)	Engineer: Roy Cheng
Probe: BBHA9120D_1-18GHz	Polarity: Vertical
EUT: WIFI dual band 4 GE LAN GPON HGU	Power: AC 120V/60Hz
Test Mode: Transmit by 802.11ac-VHT40 at channel 5510MHz Ant 0+1+2+3	

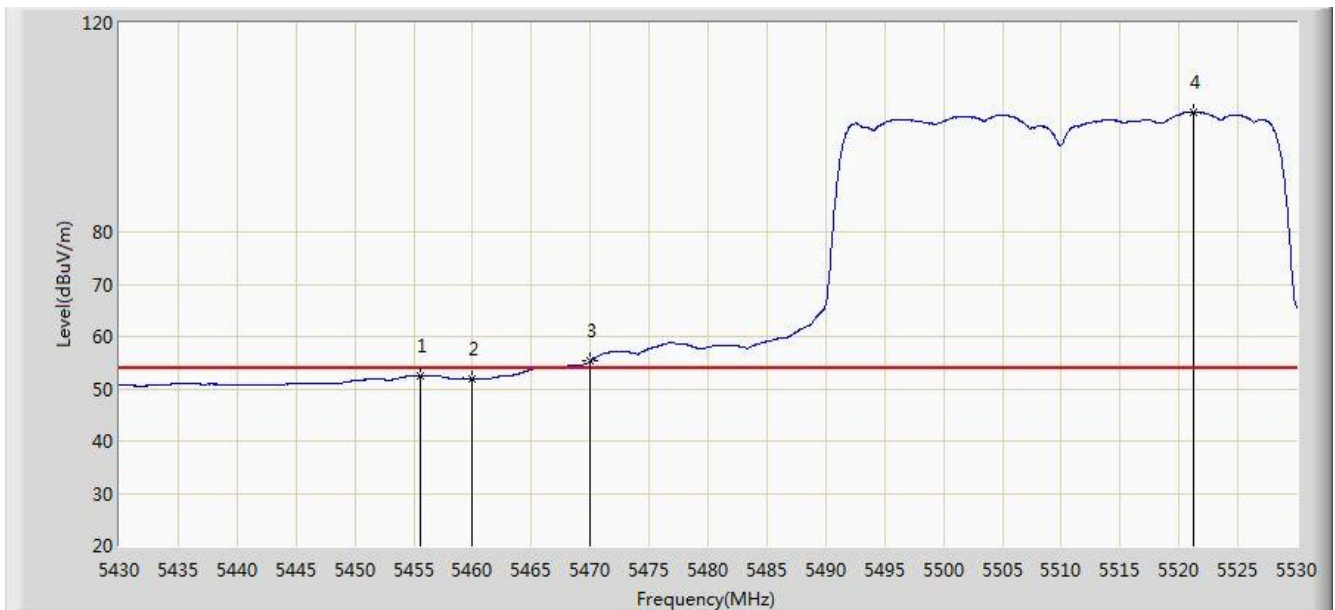

No	Flag	Mark	Frequency (MHz)	Measure Level (dBuV/m)	Reading Level (dBuV)	Over Limit (dB)	Limit (dBuV/m)	Factor (dB)	Type
1			5455.600	52.510	15.707	-1.490	54.000	36.804	AV
2			5460.000	52.002	15.192	-1.998	54.000	36.810	AV
3			5470.000	55.224	18.399	-12.976	68.200	36.825	AV
4		*	5521.250	102.849	65.930	N/A	N/A	36.919	AV

Note: Measure Level (dBuV/m) = Reading Level (dBuV) + Factor (dB)

Factor (dB) = Cable Loss (dB) + Antenna Factor (dB/m).

Site: AC1	Time: 2014/07/18 - 15:42
Limit: FCC_Part15.209_RE(3m)	Engineer: Roy Cheng
Probe: BBHA9120D_1-18GHz	Polarity: Horizontal
EUT: WIFI dual band 4 GE LAN GPON HGU	Power: AC 120V/60Hz
Test Mode: Transmit by 802.11ac-VHT40 at channel 5670MHz Ant 0+1+2+3	

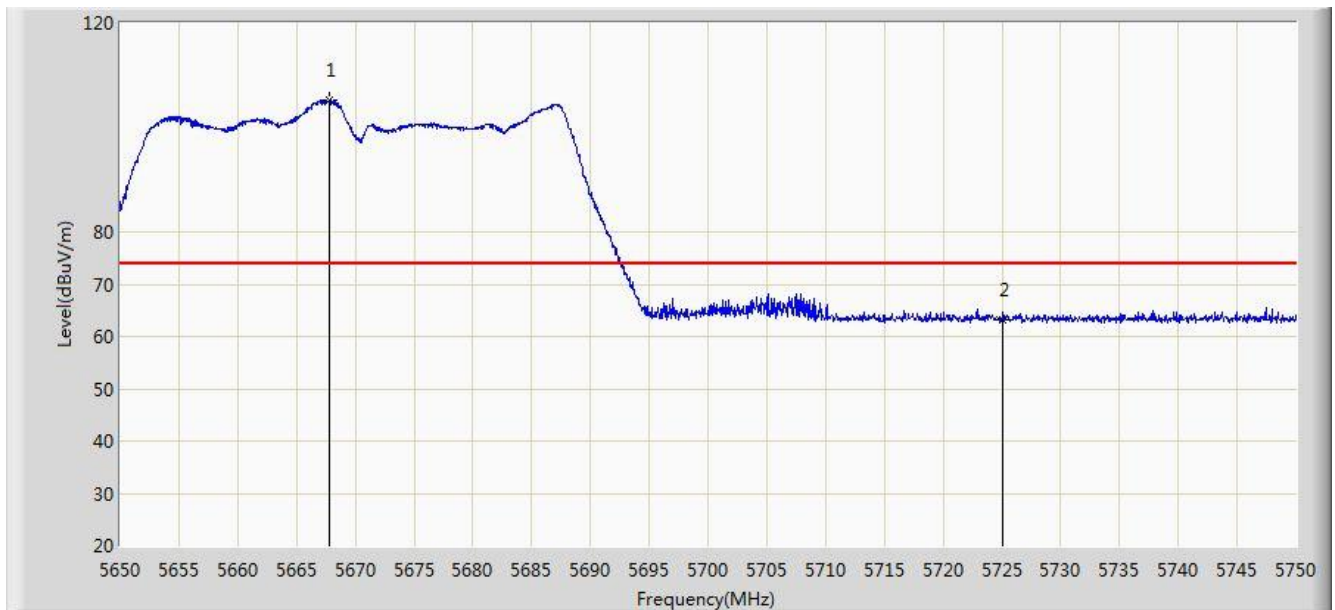

No	Flag	Mark	Frequency (MHz)	Measure Level (dBuV/m)	Reading Level (dBuV)	Over Limit (dB)	Limit (dBuV/m)	Factor (dB)	Type
1		*	5667.750	105.281	68.196	N/A	N/A	37.084	PK
2			5725.000	63.132	25.827	-10.868	74.000	37.305	PK

Note: Measure Level (dBuV/m) = Reading Level (dBuV) + Factor (dB)

Factor (dB) = Cable Loss (dB) + Antenna Factor (dB/m).

Site: AC1	Time: 2014/07/18 - 15:47
Limit: FCC_Part15.209_RE(3m)	Engineer: Roy Cheng
Probe: BBHA9120D_1-18GHz	Polarity: Horizontal
EUT: WIFI dual band 4 GE LAN GPON HGU	Power: AC 120V/60Hz
Test Mode: Transmit by 802.11ac-VHT40 at channel 5670MHz Ant 0+1+2+3	

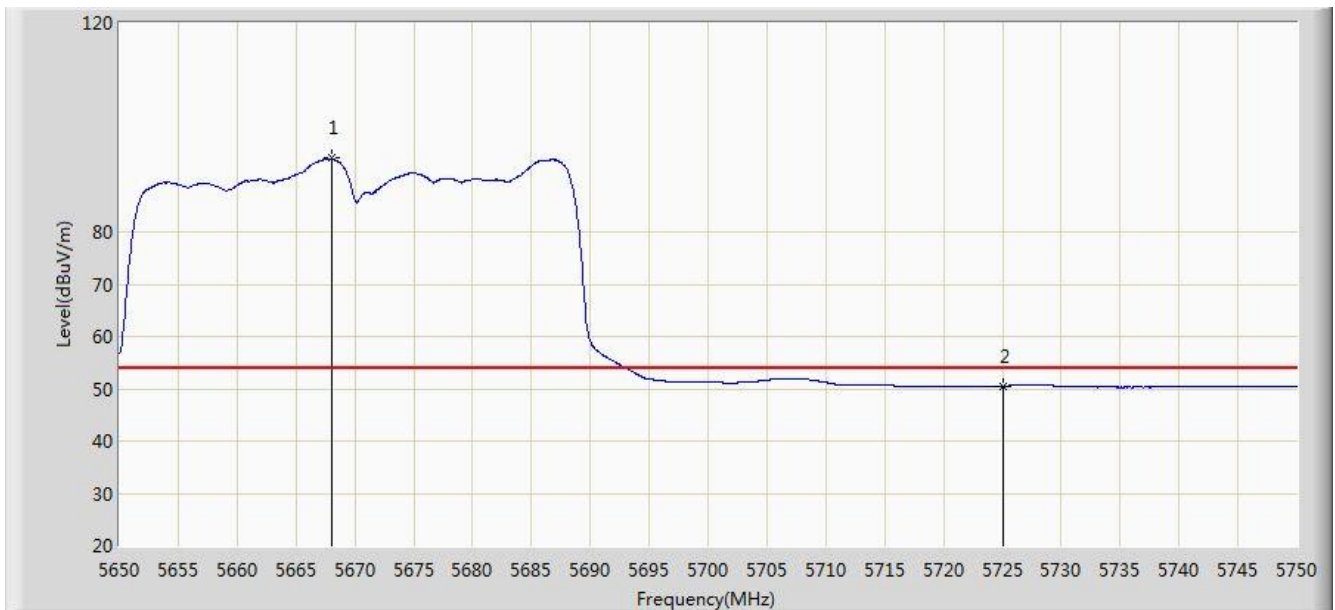

No	Flag	Mark	Frequency (MHz)	Measure Level (dBuV/m)	Reading Level (dBuV)	Over Limit (dB)	Limit (dBuV/m)	Factor (dB)	Type
1		*	5668.050	94.084	56.999	N/A	N/A	37.085	AV
2			5725.000	50.550	13.245	-3.450	54.000	37.305	AV

Note: Measure Level (dB $\mu$ V/m) = Reading Level (dB $\mu$ V) + Factor (dB)

Factor (dB) = Cable Loss (dB) + Antenna Factor (dB/m).

Site: AC1	Time: 2014/07/18 - 15:53
Limit: FCC_Part15.209_RE(3m)	Engineer: Roy Cheng
Probe: BBHA9120D_1-18GHz	Polarity: Vertical
EUT: WIFI dual band 4 GE LAN GPON HGU	Power: AC 120V/60Hz
Test Mode: Transmit by 802.11ac-VHT40 at channel 5670MHz Ant 0+1+2+3	

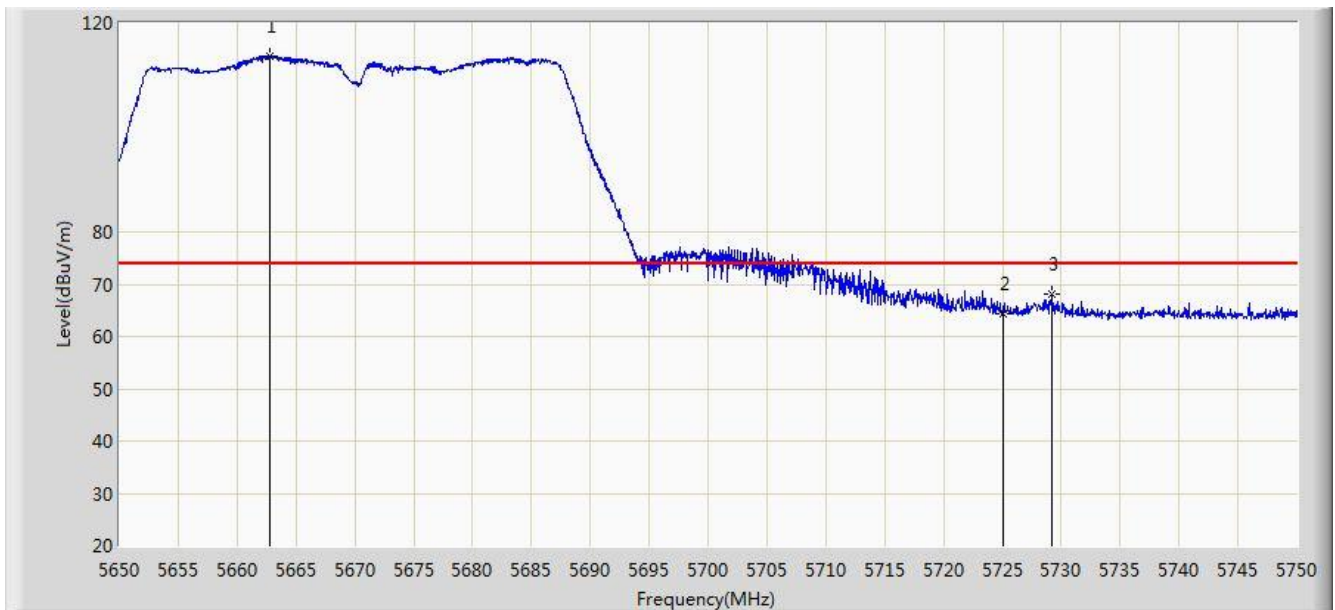

No	Flag	Mark	Frequency (MHz)	Measure Level (dBuV/m)	Reading Level (dBuV)	Over Limit (dB)	Limit (dBuV/m)	Factor (dB)	Type
1		*	5662.750	113.710	76.636	N/A	N/A	37.074	PK
2			5725.000	64.323	27.018	-9.677	74.000	37.305	PK
3			5729.150	68.234	30.912	-5.766	74.000	37.322	PK

Note: Measure Level (dB $\mu$ V/m) = Reading Level (dB $\mu$ V) + Factor (dB)

Factor (dB) = Cable Loss (dB) + Antenna Factor (dB/m).

Site: AC1	Time: 2014/07/18 - 15:55
Limit: FCC_Part15.209_RE(3m)	Engineer: Roy Cheng
Probe: BBHA9120D_1-18GHz	Polarity: Vertical
EUT: WIFI dual band 4 GE LAN GPON HGU	Power: AC 120V/60Hz
Test Mode: Transmit by 802.11ac-VHT40 at channel 5670MHz Ant 0+1+2+3	

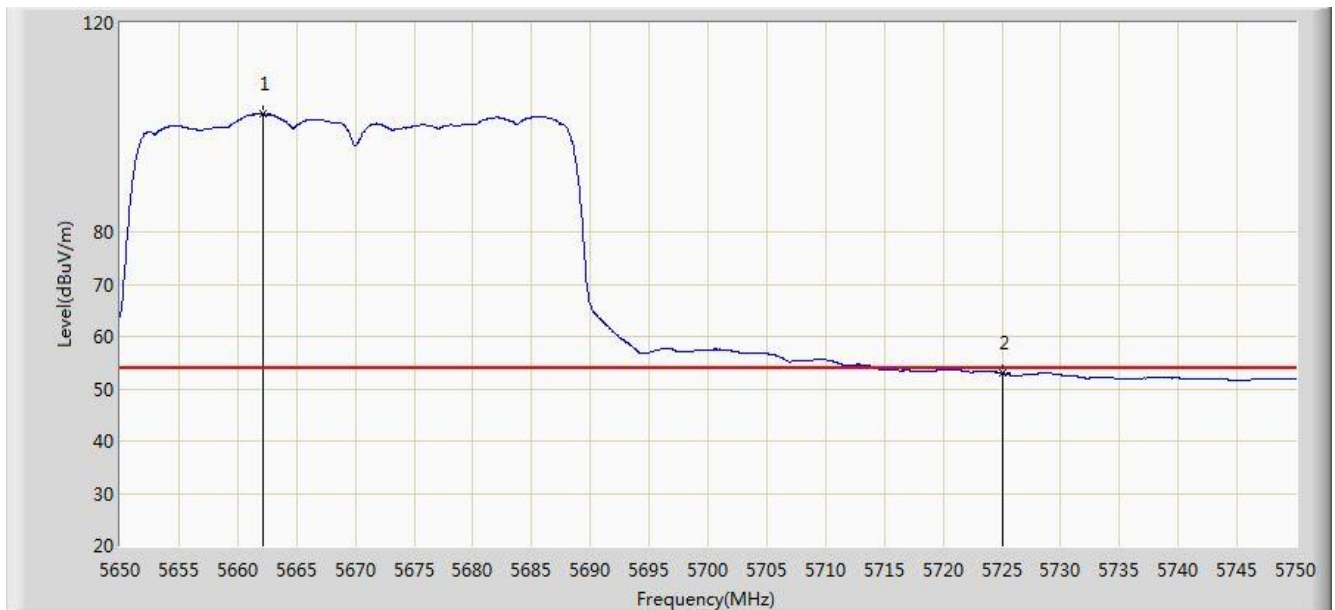

No	Flag	Mark	Frequency (MHz)	Measure Level (dBuV/m)	Reading Level (dBuV)	Over Limit (dB)	Limit (dBuV/m)	Factor (dB)	Type
1		*	5662.100	102.542	65.469	N/A	N/A	37.072	AV
2			5725.000	52.996	15.691	-1.004	54.000	37.305	AV

Note: Measure Level (dBuV/m) = Reading Level (dBuV) + Factor (dB)

Factor (dB) = Cable Loss (dB) + Antenna Factor (dB/m).

Site: AC1	Time: 2015/02/11 - 17:32
Limit: FCC 15.407	Engineer: Roy Cheng
Probe: BBHA9120D_1-18GHz	Polarity: Horizontal
EUT: WIFI dual band 4 GE LAN GPON HGU	Power: AC 120V/60Hz
Test Mode: Transmit at channel 5755MHz by 802.11ac-VHT40 Ant 0+1+2+3	

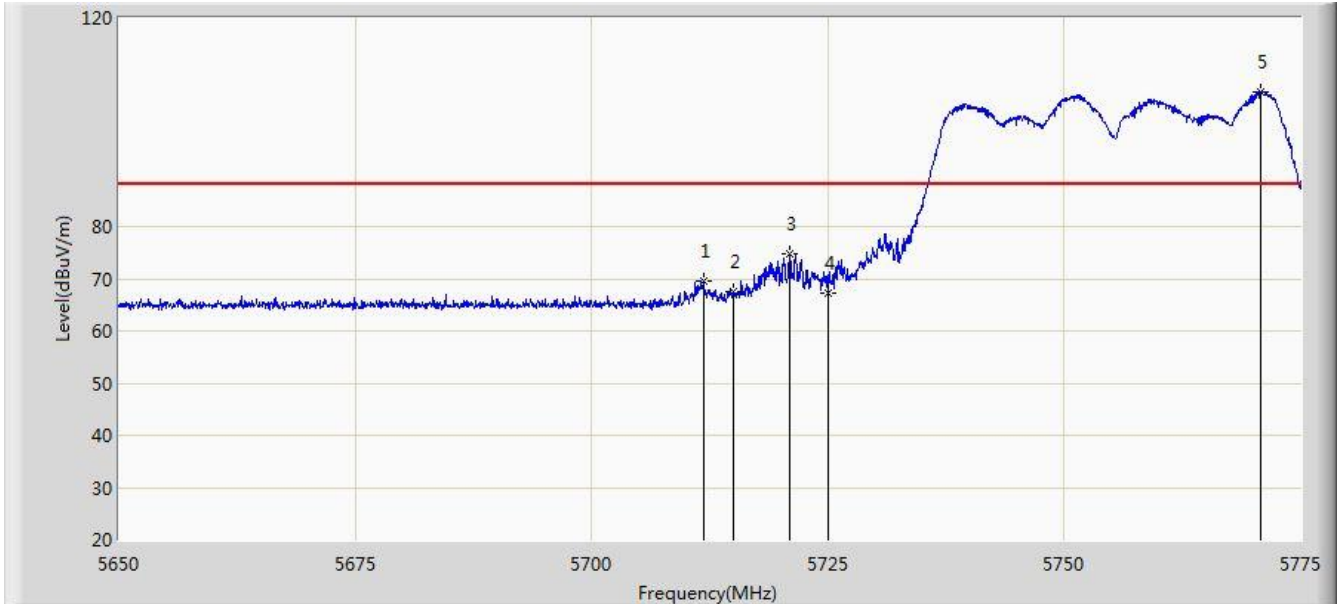

No	Flag	Mark	Frequency (MHz)	Measure Level (dBuV/m)	Reading Level (dBuV)	Over Limit (dB)	Limit (dBuV/m)	Factor (dB)	Type
1			5711.812	69.468	31.532	-18.732	88.200	37.937	PK
2			5715.000	67.498	29.549	-20.702	88.200	37.949	PK
3			5720.937	74.691	36.718	-23.509	98.200	37.973	PK
4			5725.000	67.297	29.307	-30.903	98.200	37.990	PK
5		*	5770.750	105.814	67.646	N/A	N/A	38.168	PK

Note: Measure Level (dB $\mu$ V/m) = Reading Level (dB $\mu$ V) + Factor (dB)

Factor (dB) = Cable Loss (dB) + Antenna Factor (dB/m).



Site: AC1	Time: 2015/02/11 - 17:35
Limit: FCC 15.407	Engineer: Roy Cheng
Probe: BBHA9120D_1-18GHz	Polarity: Horizontal
EUT: WIFI dual band 4 GE LAN GPON HGU	Power: AC 120V/60Hz
Test Mode: Transmit at channel 5755MHz by 802.11ac-VHT40 Ant 0+1+2+3	

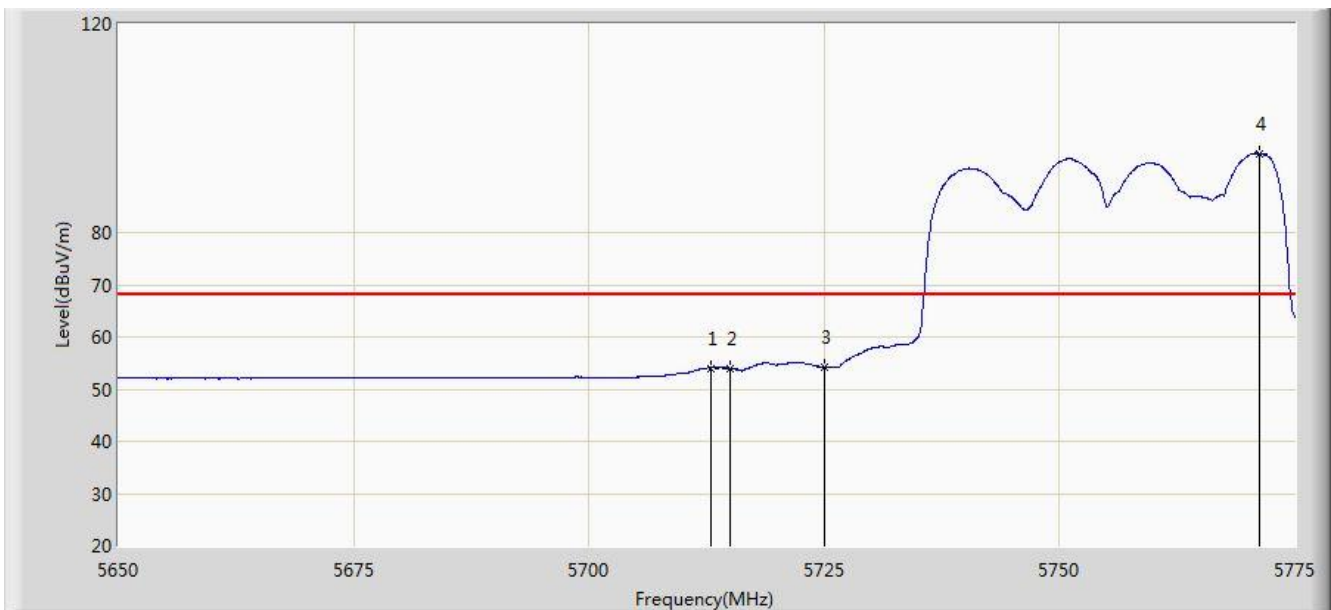

No	Flag	Mark	Frequency (MHz)	Measure Level (dBuV/m)	Reading Level (dBuV)	Over Limit (dB)	Limit (dBuV/m)	Factor (dB)	Type
1			5712.937	54.043	16.102	-14.157	68.200	37.941	AV
2			5715.000	53.940	15.991	-14.260	68.200	37.949	AV
3			5725.000	54.309	16.319	-23.891	78.200	37.990	AV
4		*	5771.250	95.145	56.976	N/A	N/A	38.169	AV

Note: Measure Level (dBuV/m) = Reading Level (dBuV) + Factor (dB)

Factor (dB) = Cable Loss (dB) + Antenna Factor (dB/m).

Site: AC1	Time: 2015/02/11 - 17:40
Limit: FCC 15.407	Engineer: Roy Cheng
Probe: BBHA9120D_1-18GHz	Polarity: Vertical
EUT: WIFI dual band 4 GE LAN GPON HGU	Power: AC 120V/60Hz
Test Mode: Transmit at channel 5755MHz by 802.11ac-VHT40 Ant 0+1+2+3	

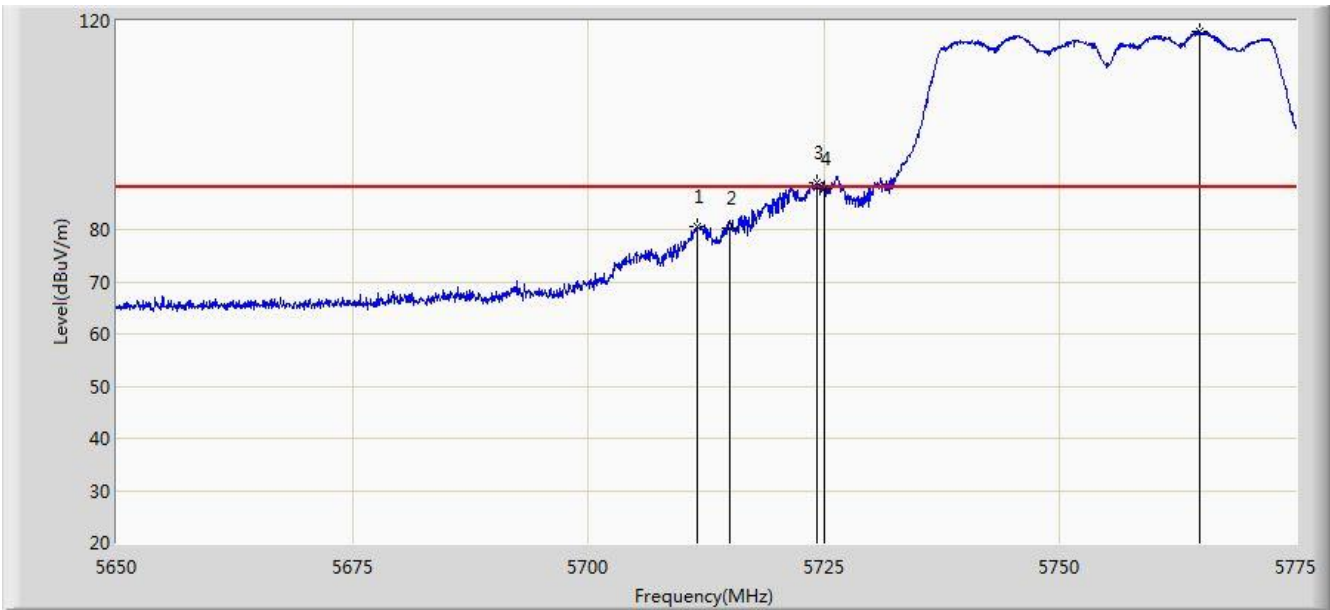

No	Flag	Mark	Frequency (MHz)	Measure Level (dBuV/m)	Reading Level (dBuV)	Over Limit (dB)	Limit (dBuV/m)	Factor (dB)	Type
1			5711.625	80.504	42.568	-7.696	88.200	37.936	PK
2			5715.000	80.183	42.234	-8.017	88.200	37.949	PK
3			5724.250	88.875	50.888	-9.325	98.200	37.987	PK
4			5725.000	87.686	49.696	-10.514	98.200	37.990	PK
5		*	5764.812	117.913	79.760	N/A	N/A	38.153	PK

Note: Measure Level (dB $\mu$ V/m) = Reading Level (dB $\mu$ V) + Factor (dB)

Factor (dB) = Cable Loss (dB) + Antenna Factor (dB/m).

Site: AC1	Time: 2015/02/11 - 17:41
Limit: FCC 15.407	Engineer: Roy Cheng
Probe: BBHA9120D_1-18GHz	Polarity: Vertical
EUT: WIFI dual band 4 GE LAN GPON HGU	Power: AC 120V/60Hz
Test Mode: Transmit at channel 5755MHz by 802.11ac-VHT40 Ant 0+1+2+3	

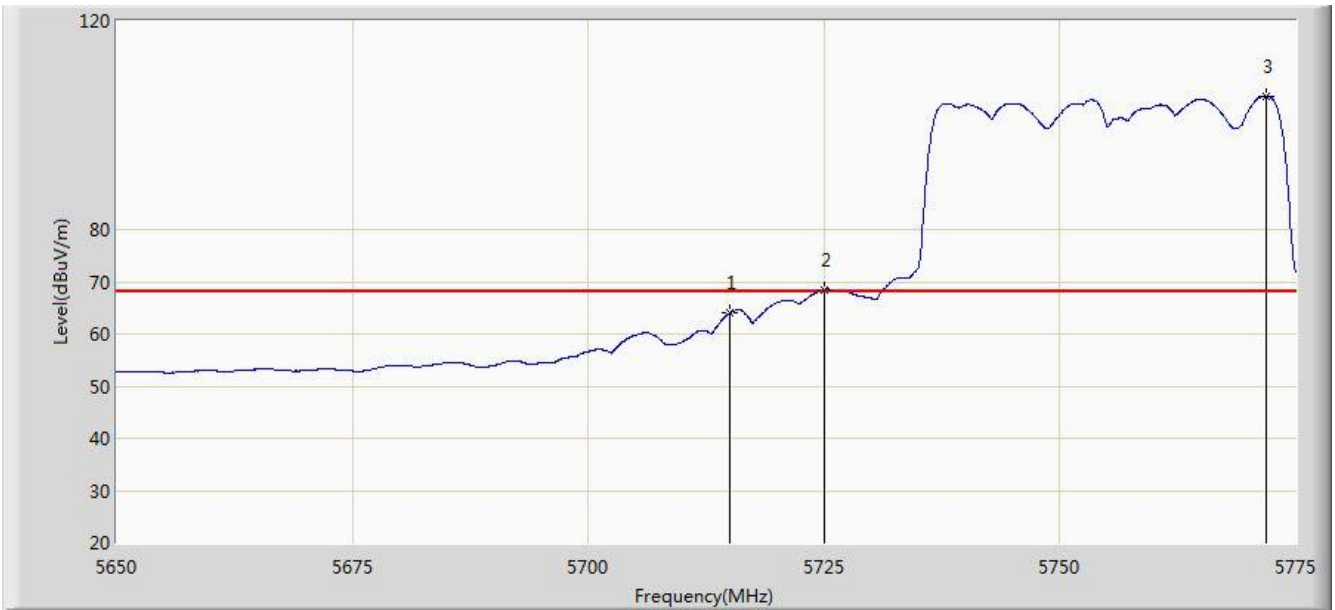

No	Flag	Mark	Frequency (MHz)	Measure Level (dBuV/m)	Reading Level (dBuV)	Over Limit (dB)	Limit (dBuV/m)	Factor (dB)	Type
1			5715.000	63.940	25.991	-4.260	68.200	37.949	AV
2			5725.000	68.418	30.428	-9.782	78.200	37.990	AV
3		*	5771.812	105.575	67.405	N/A	N/A	38.171	AV

Note: Measure Level (dB $\mu$ V/m) = Reading Level (dB $\mu$ V) + Factor (dB)

Factor (dB) = Cable Loss (dB) + Antenna Factor (dB/m).

Site: AC1	Time: 2015/02/11 - 17:43
Limit: FCC 15.407	Engineer: Roy Cheng
Probe: BBHA9120D_1-18GHz	Polarity: Horizontal
EUT: WIFI dual band 4 GE LAN GPON HGU	Power: AC 120V/60Hz
Test Mode: Transmit at channel 5795MHz by 802.11ac-VHT40 Ant 0+1+2+3	

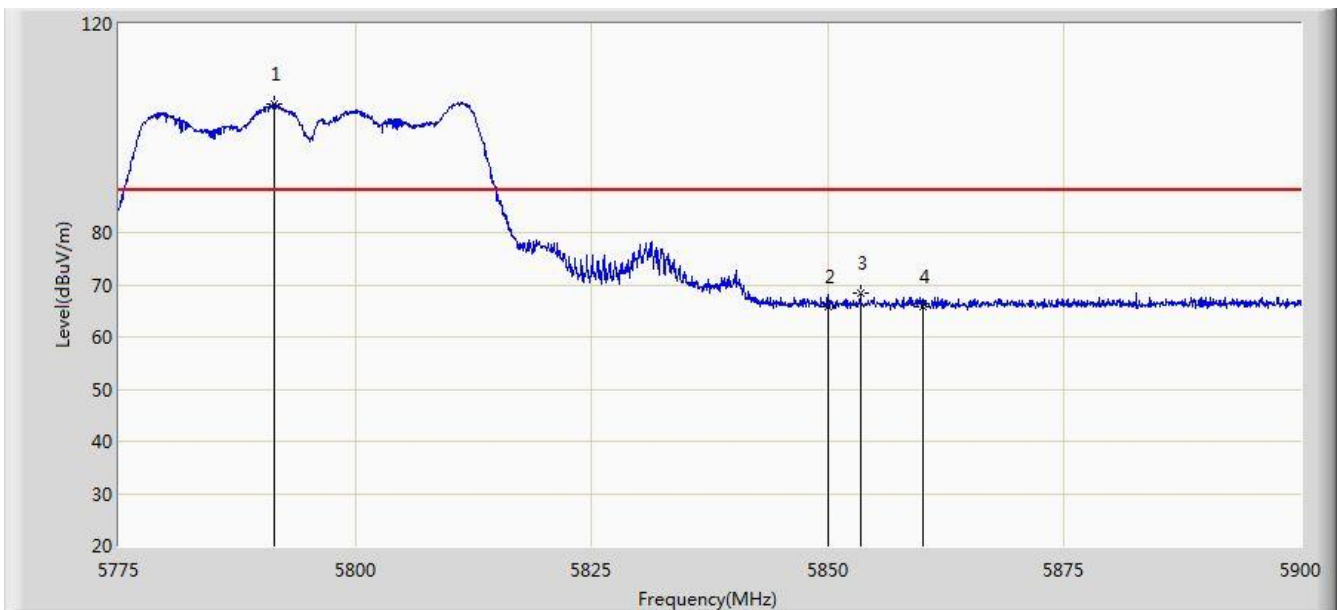

No	Flag	Mark	Frequency (MHz)	Measure Level (dBuV/m)	Reading Level (dBuV)	Over Limit (dB)	Limit (dBuV/m)	Factor (dB)	Type
1		*	5791.437	104.675	66.439	N/A	N/A	38.236	PK
2			5850.000	65.840	27.387	-32.360	98.200	38.454	PK
3			5853.437	68.448	29.986	-29.752	98.200	38.462	PK
4			5860.000	65.916	27.438	-22.284	88.200	38.478	PK

Note: Measure Level (dB $\mu$ V/m) = Reading Level (dB $\mu$ V) + Factor (dB)

Factor (dB) = Cable Loss (dB) + Antenna Factor (dB/m).

Site: AC1	Time: 2015/02/11 - 17:45
Limit: FCC 15.407	Engineer: Roy Cheng
Probe: BBHA9120D_1-18GHz	Polarity: Horizontal
EUT: WIFI dual band 4 GE LAN GPON HGU	Power: AC 120V/60Hz
Test Mode: Transmit at channel 5795MHz by 802.11ac-VHT40 Ant 0+1+2+3	

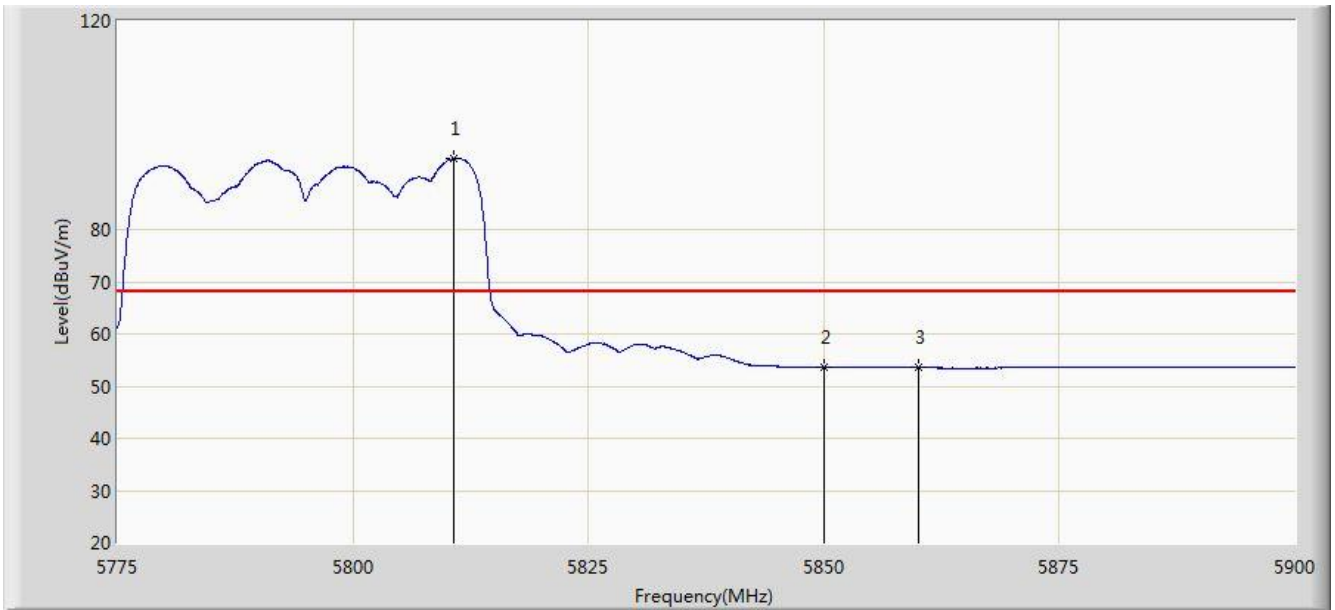

No	Flag	Mark	Frequency (MHz)	Measure Level (dBuV/m)	Reading Level (dBuV)	Over Limit (dB)	Limit (dBuV/m)	Factor (dB)	Type
1		*	5810.687	93.616	55.320	N/A	N/A	38.296	AV
2			5850.000	53.627	15.174	-24.573	78.200	38.454	AV
3			5860.000	53.578	15.100	-14.622	68.200	38.478	AV

Note: Measure Level (dB $\mu$ V/m) = Reading Level (dB $\mu$ V) + Factor (dB)

Factor (dB) = Cable Loss (dB) + Antenna Factor (dB/m).

Site: AC1	Time: 2015/02/11 - 17:49
Limit: FCC 15.407	Engineer: Roy Cheng
Probe: BBHA9120D_1-18GHz	Polarity: Vertical
EUT: WIFI dual band 4 GE LAN GPON HGU	Power: AC 120V/60Hz
Test Mode: Transmit at channel 5795MHz by 802.11ac-VHT40 Ant 0+1+2+3	

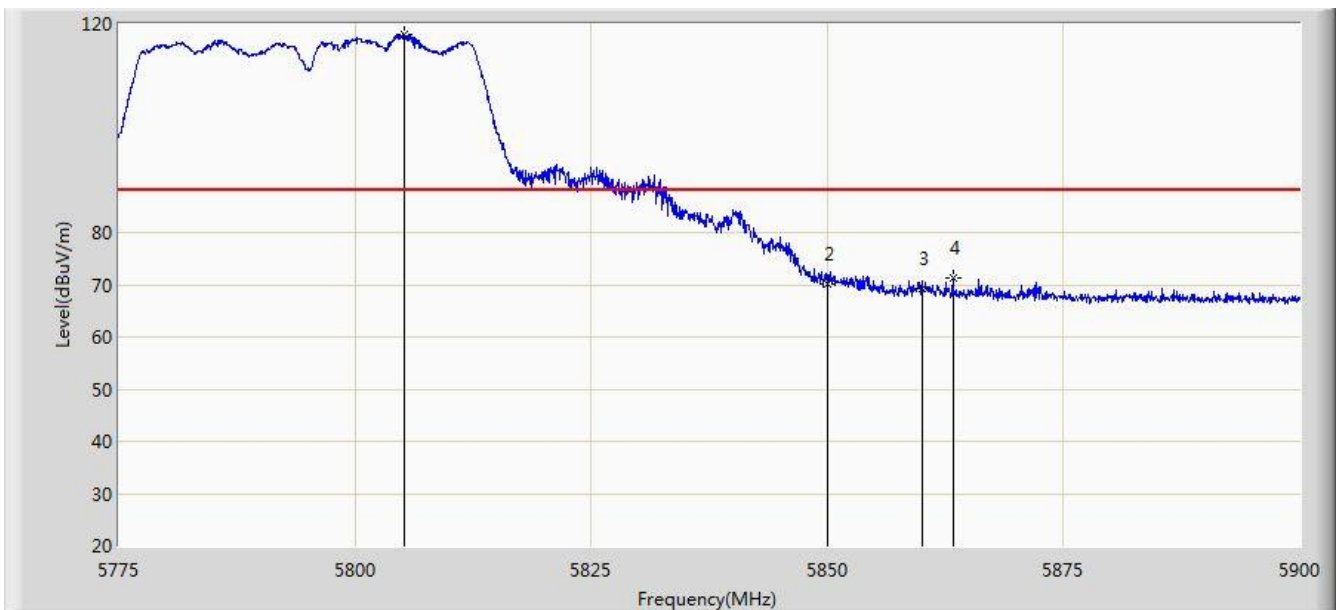

No	Flag	Mark	Frequency (MHz)	Measure Level (dBuV/m)	Reading Level (dBuV)	Over Limit (dB)	Limit (dBuV/m)	Factor (dB)	Type
1		*	5805.250	117.850	79.570	N/A	N/A	38.280	PK
2			5850.000	70.185	31.732	-28.015	98.200	38.454	PK
3			5860.000	69.291	30.813	-18.909	88.200	38.478	PK
4			5863.312	71.318	32.834	-16.882	88.200	38.484	PK

Note: Measure Level (dBuV/m) = Reading Level (dBuV) + Factor (dB)

Factor (dB) = Cable Loss (dB) + Antenna Factor (dB/m).

Site: AC1	Time: 2015/02/11 - 17:51
Limit: FCC 15.407	Engineer: Roy Cheng
Probe: BBHA9120D_1-18GHz	Polarity: Vertical
EUT: WIFI dual band 4 GE LAN GPON HGU	Power: AC 120V/60Hz
Test Mode: Transmit at channel 5795MHz by 802.11ac-VHT40 Ant 0+1+2+3	

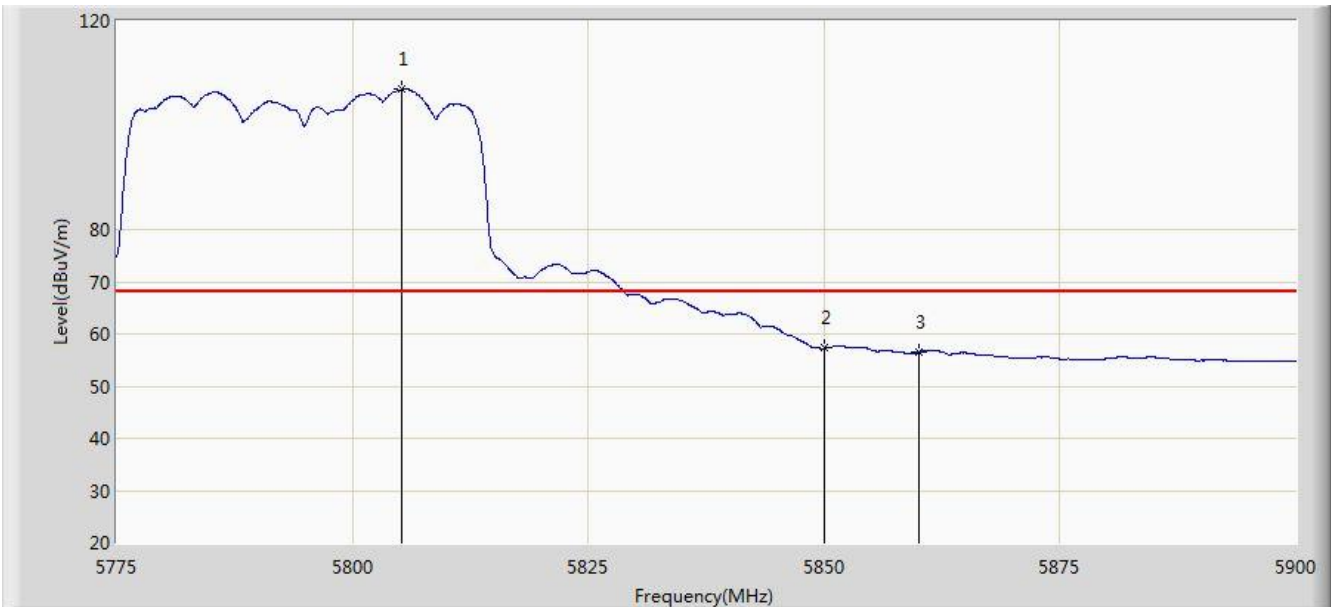

No	Flag	Mark	Frequency (MHz)	Measure Level (dBuV/m)	Reading Level (dBuV)	Over Limit (dB)	Limit (dBuV/m)	Factor (dB)	Type
1		*	5805.250	106.887	68.607	N/A	N/A	38.280	AV
2			5850.000	57.271	18.818	-20.929	78.200	38.454	AV
3			5860.000	56.472	17.994	-11.728	68.200	38.478	AV

Note: Measure Level (dB $\mu$ V/m) = Reading Level (dB $\mu$ V) + Factor (dB)

Factor (dB) = Cable Loss (dB) + Antenna Factor (dB/m).

Site: AC1	Time: 2015/02/11 - 20:35
Limit: FCC_Part15.209_RE(3m)	Engineer: Roy Cheng
Probe: BBHA9120D_1-18GHz	Polarity: Horizontal
EUT: WIFI dual band 4 GE LAN GPON HGU	Power: AC 120V/60Hz
Test Mode: Transmit at channel 5210MHz by 802.11ac-VHT80 Ant 0+1+2+3	

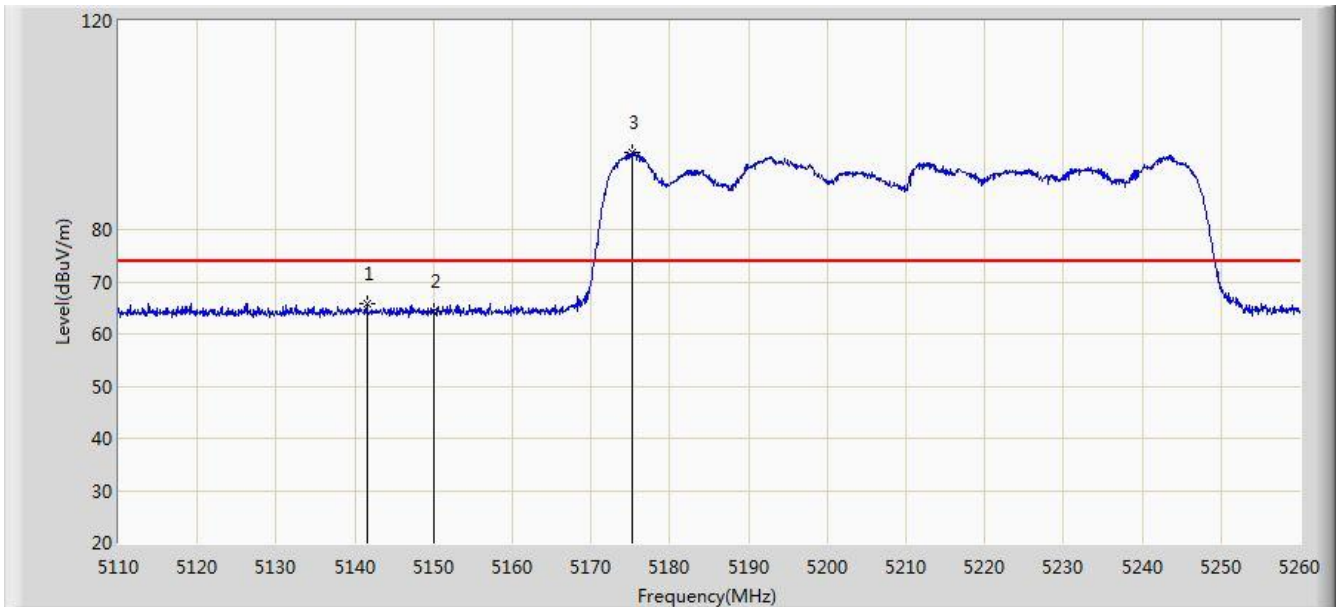

No	Flag	Mark	Frequency (MHz)	Measure Level (dBuV/m)	Reading Level (dBuV)	Over Limit (dB)	Limit (dBuV/m)	Factor (dB)	Type
1			5141.500	65.913	28.448	-8.087	74.000	37.465	PK
2			5150.000	64.343	26.891	-9.657	74.000	37.452	PK
3		*	5175.175	94.752	57.367	N/A	N/A	37.385	PK

Note: Measure Level (dB $\mu$ V/m) = Reading Level (dB $\mu$ V) + Factor (dB)

Factor (dB) = Cable Loss (dB) + Antenna Factor (dB/m).



Site: AC1	Time: 2015/02/11 - 20:35
Limit: FCC_Part15.209_RE(3m)	Engineer: Roy Cheng
Probe: BBHA9120D_1-18GHz	Polarity: Horizontal
EUT: WIFI dual band 4 GE LAN GPON HGU	Power: AC 120V/60Hz
Test Mode: Transmit at channel 5210MHz by 802.11ac-VHT80 Ant 0+1+2+3	

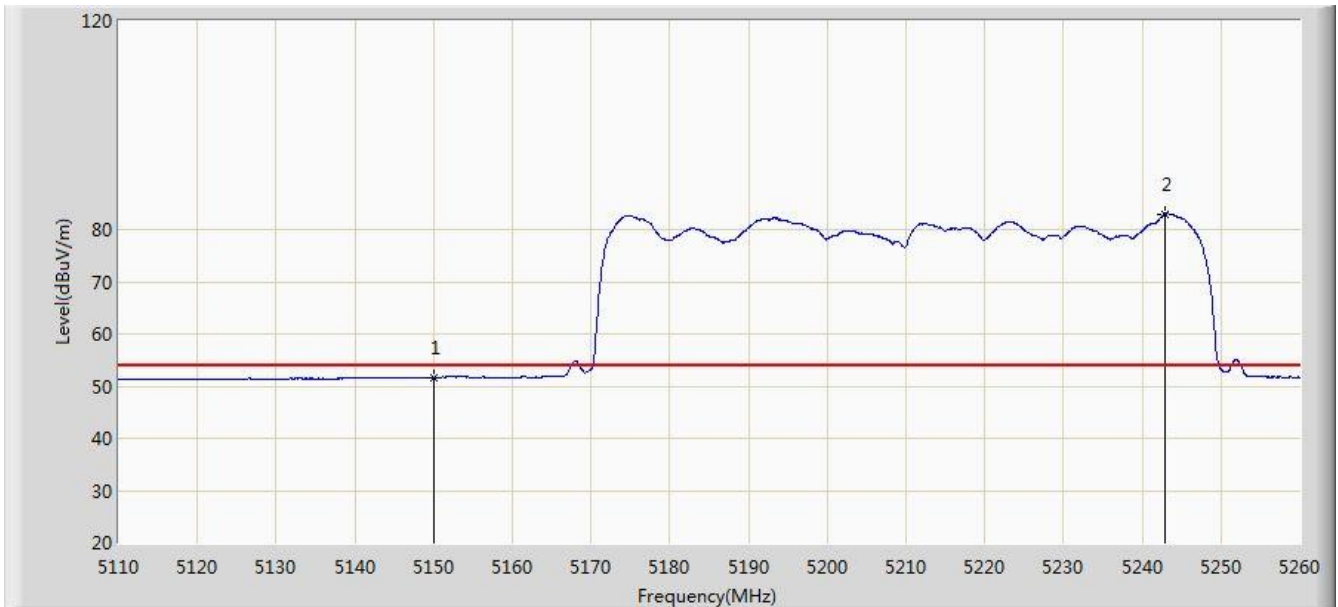

No	Flag	Mark	Frequency (MHz)	Measure Level (dBuV/m)	Reading Level (dBuV)	Over Limit (dB)	Limit (dBuV/m)	Factor (dB)	Type
1			5150.000	51.611	14.159	-2.389	54.000	37.452	AV
2		*	5242.900	83.030	45.821	N/A	N/A	37.210	AV

Note: Measure Level (dB $\mu$ V/m) = Reading Level (dB $\mu$ V) + Factor (dB)

Factor (dB) = Cable Loss (dB) + Antenna Factor (dB/m).

Site: AC1	Time: 2015/02/11 - 20:43
Limit: FCC_Part15.209_RE(3m)	Engineer: Roy Cheng
Probe: BBHA9120D_1-18GHz	Polarity: Vertical
EUT: WIFI dual band 4 GE LAN GPON HGU	Power: AC 120V/60Hz
Test Mode: Transmit at channel 5210MHz by 802.11ac-VHT80 Ant 0+1+2+3	

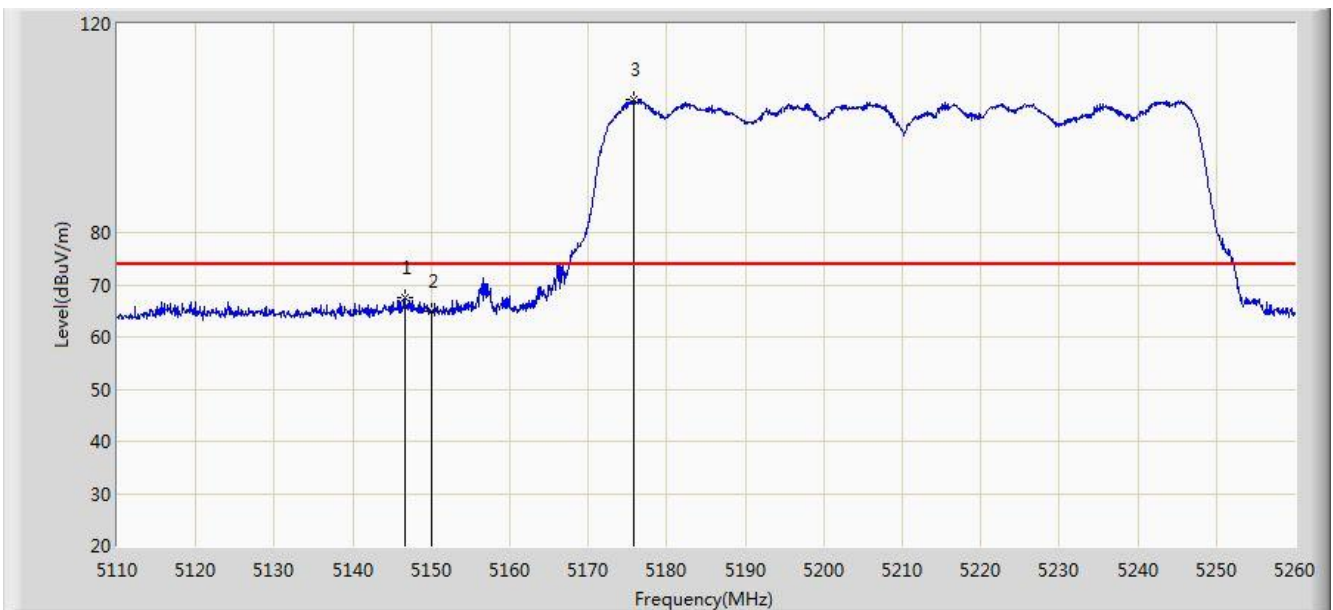

No	Flag	Mark	Frequency (MHz)	Measure Level (dBuV/m)	Reading Level (dBuV)	Over Limit (dB)	Limit (dBuV/m)	Factor (dB)	Type
1			5146.600	67.479	30.022	-6.521	74.000	37.457	PK
2			5150.000	64.875	27.423	-9.125	74.000	37.452	PK
3		*	5175.700	105.400	68.017	N/A	N/A	37.384	PK

Note: Measure Level (dB $\mu$ V/m) = Reading Level (dB $\mu$ V) + Factor (dB)

Factor (dB) = Cable Loss (dB) + Antenna Factor (dB/m).

Site: AC1	Time: 2015/02/11 - 20:39
Limit: FCC_Part15.209_RE(3m)	Engineer: Roy Cheng
Probe: BBHA9120D_1-18GHz	Polarity: Vertical
EUT: WIFI dual band 4 GE LAN GPON HGU	Power: AC 120V/60Hz
Test Mode: Transmit at channel 5210MHz by 802.11ac-VHT80 Ant 0+1+2+3	

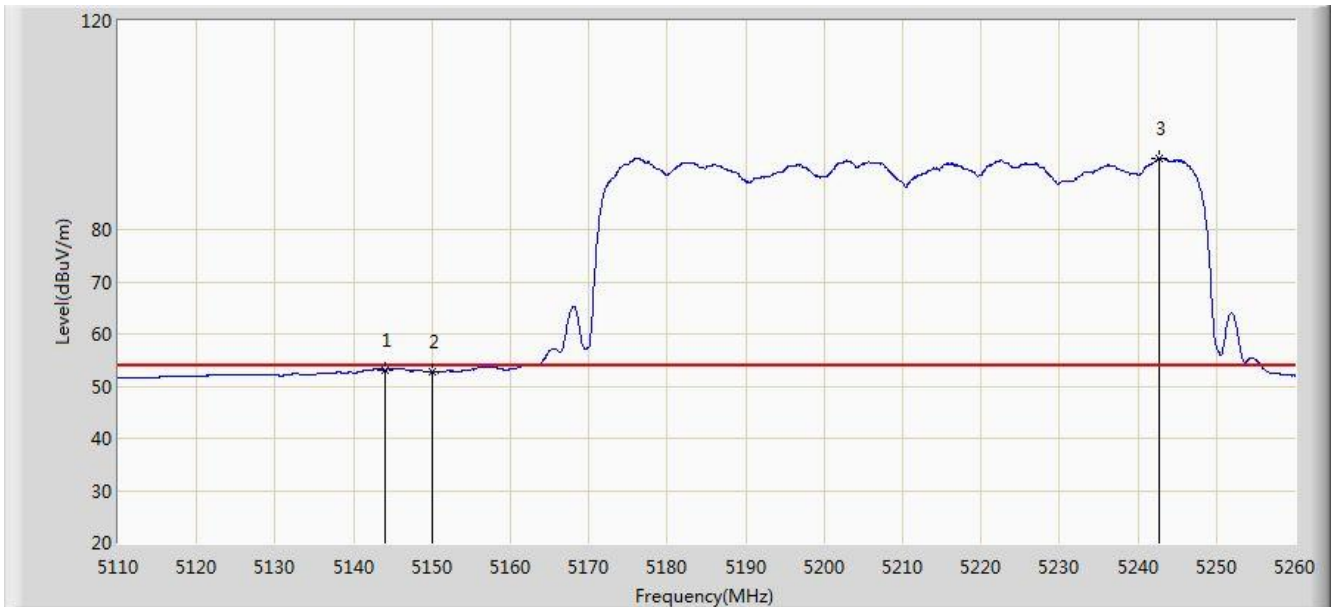

No	Flag	Mark	Frequency (MHz)	Measure Level (dBuV/m)	Reading Level (dBuV)	Over Limit (dB)	Limit (dBuV/m)	Factor (dB)	Type
1			5143.975	53.140	15.679	-0.860	54.000	37.461	AV
2			5150.000	52.733	15.281	-1.267	54.000	37.452	AV
3		*	5242.675	93.492	56.282	N/A	N/A	37.210	AV

Note: Measure Level (dB $\mu$ V/m) = Reading Level (dB $\mu$ V) + Factor (dB)

Factor (dB) = Cable Loss (dB) + Antenna Factor (dB/m).

Site: AC1	Time: 2014/07/18 - 16:26
Limit: FCC_Part15.209_RE(3m)	Engineer: Roy Cheng
Probe: BBHA9120D_1-18GHz	Polarity: Horizontal
EUT: WIFI dual band 4 GE LAN GPON HGU	Power: AC 120V/60Hz
Test Mode: Transmit by 802.11ac-VHT80 at channel 5290MHz Ant 0+1+2+3	

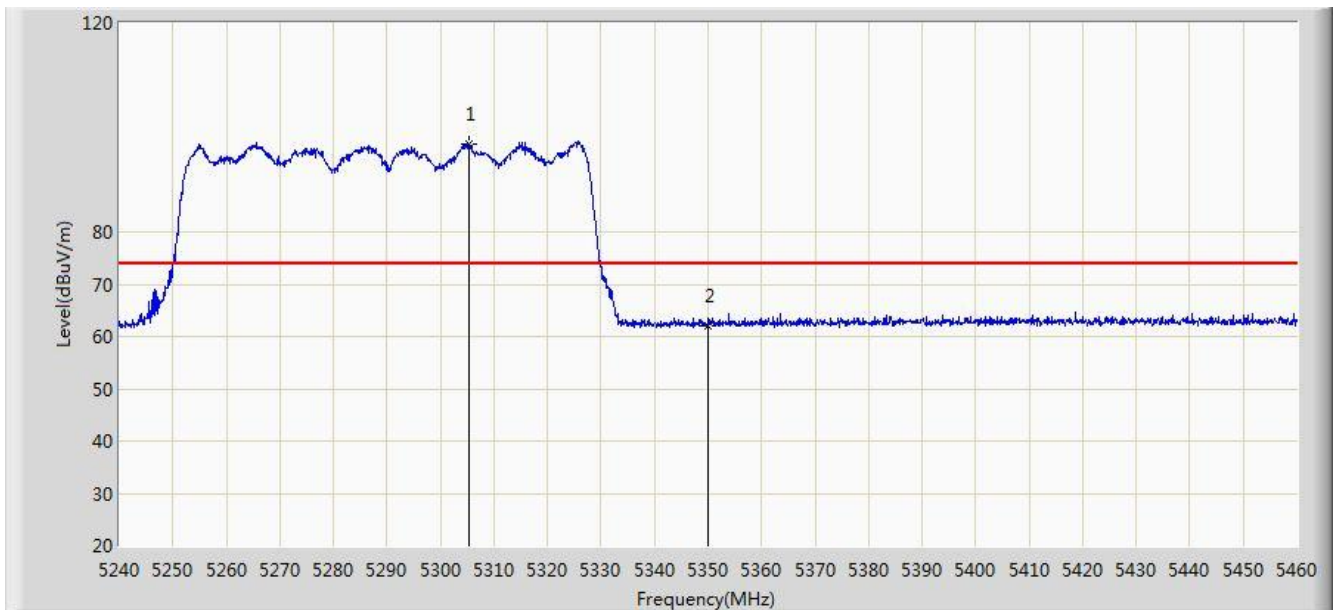

No	Flag	Mark	Frequency (MHz)	Measure Level (dBuV/m)	Reading Level (dBuV)	Over Limit (dB)	Limit (dBuV/m)	Factor (dB)	Type
1		*	5305.230	96.732	60.289	N/A	N/A	36.442	PK
2			5350.000	62.074	25.538	-11.926	74.000	36.536	PK

Note: Measure Level (dBuV/m) = Reading Level (dBuV) + Factor (dB)

Factor (dB) = Cable Loss (dB) + Antenna Factor (dB/m).

Site: AC1	Time: 2014/07/18 - 16:29
Limit: FCC_Part15.209_RE(3m)	Engineer: Roy Cheng
Probe: BBHA9120D_1-18GHz	Polarity: Horizontal
EUT: WIFI dual band 4 GE LAN GPON HGU	Power: AC 120V/60Hz
Test Mode: Transmit by 802.11ac-VHT80 at channel 5290MHz Ant 0+1+2+3	

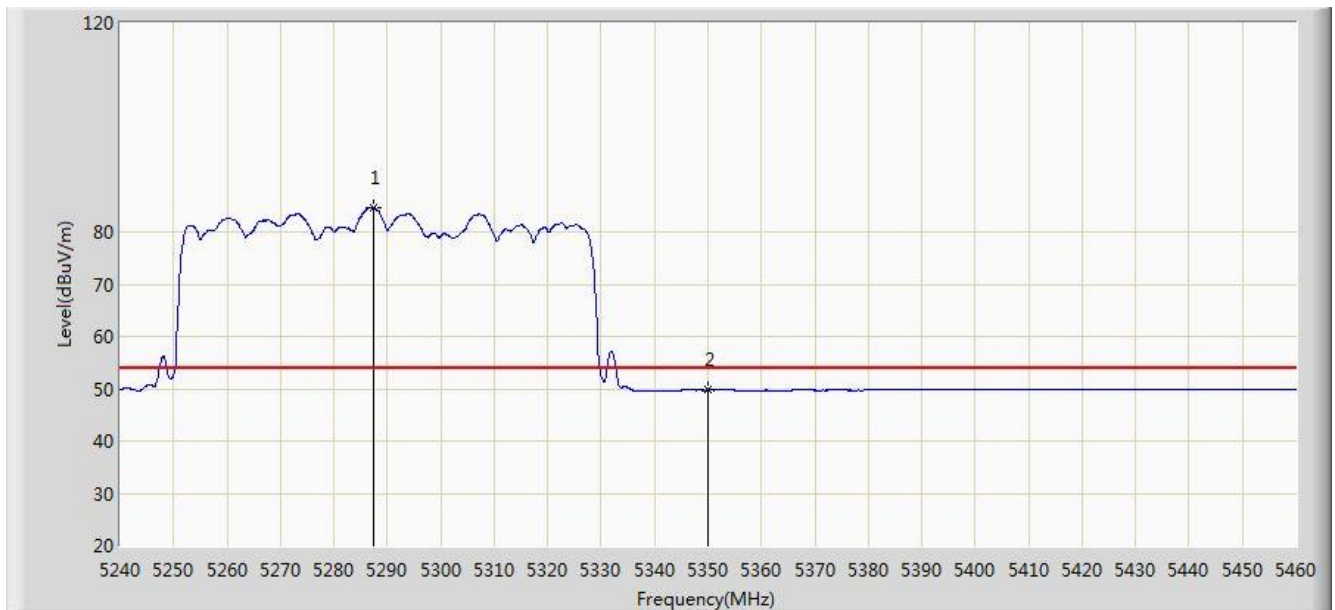

No	Flag	Mark	Frequency (MHz)	Measure Level (dBuV/m)	Reading Level (dBuV)	Over Limit (dB)	Limit (dBuV/m)	Factor (dB)	Type
1		*	5287.410	84.640	48.208	N/A	N/A	36.432	AV
2			5350.000	49.745	13.209	-4.255	54.000	36.536	AV

Note: Measure Level (dB $\mu$ V/m) = Reading Level (dB $\mu$ V) + Factor (dB)

Factor (dB) = Cable Loss (dB) + Antenna Factor (dB/m).

Site: AC1	Time: 2014/07/18 - 16:34
Limit: FCC_Part15.209_RE(3m)	Engineer: Roy Cheng
Probe: BBHA9120D_1-18GHz	Polarity: Vertical
EUT: WIFI dual band 4 GE LAN GPON HGU	Power: AC 120V/60Hz
Test Mode: Transmit by 802.11ac-VHT80 at channel 5290MHz Ant 0+1+2+3	

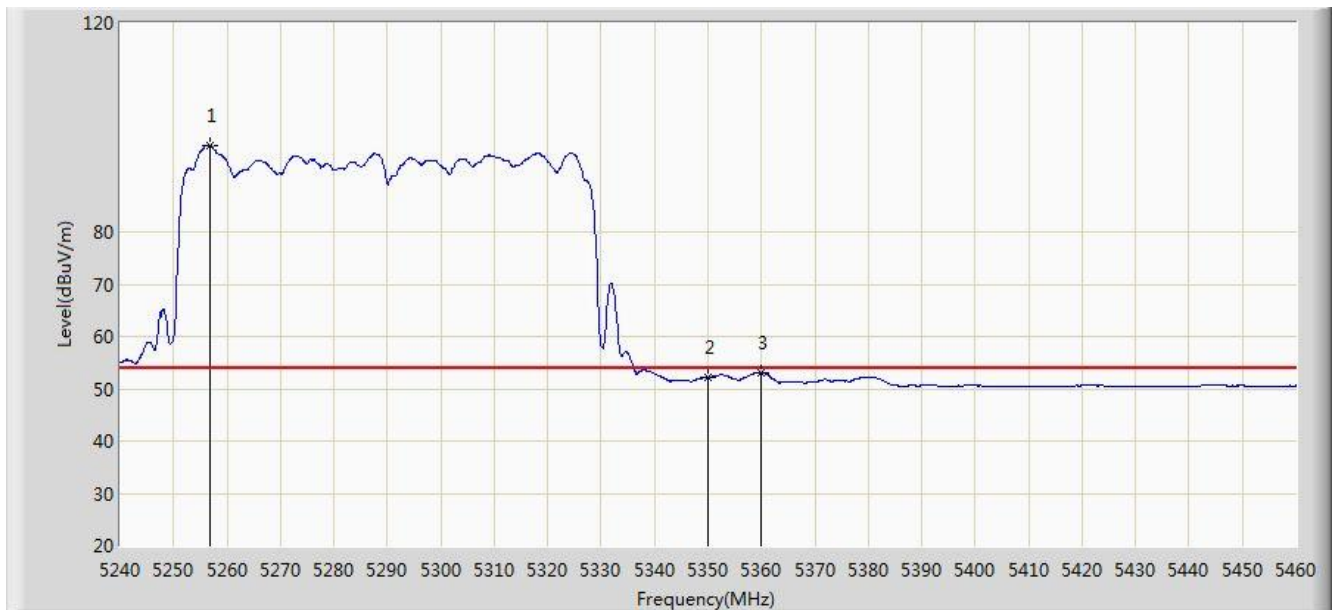

No	Flag	Mark	Frequency (MHz)	Measure Level (dBuV/m)	Reading Level (dBuV)	Over Limit (dB)	Limit (dBuV/m)	Factor (dB)	Type
1		*	5256.830	96.562	60.101	N/A	N/A	36.462	AV
2			5350.000	52.195	15.659	-1.805	54.000	36.536	AV
3			5360.010	53.085	16.525	-0.915	54.000	36.560	AV

Note: Measure Level (dB $\mu$ V/m) = Reading Level (dB $\mu$ V) + Factor (dB)

Factor (dB) = Cable Loss (dB) + Antenna Factor (dB/m).

Site: AC1	Time: 2014/07/18 - 16:34
Limit: FCC_Part15.209_RE(3m)	Engineer: Roy Cheng
Probe: BBHA9120D_1-18GHz	Polarity: Vertical
EUT: WIFI dual band 4 GE LAN GPON HGU	Power: AC 120V/60Hz
Test Mode: Transmit by 802.11ac-VHT80 at channel 5290MHz Ant 0+1+2+3	

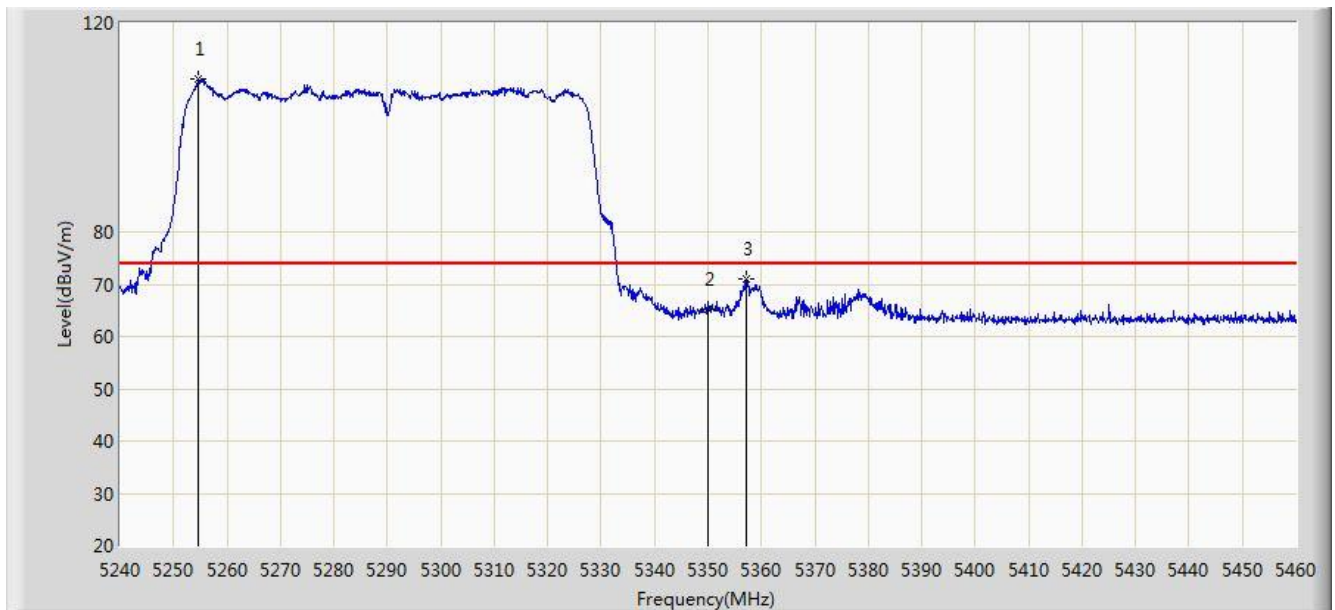

No	Flag	Mark	Frequency (MHz)	Measure Level (dBuV/m)	Reading Level (dBuV)	Over Limit (dB)	Limit (dBuV/m)	Factor (dB)	Type
1		*	5254.740	109.345	72.882	N/A	N/A	36.466	PK
2			5350.000	65.269	28.733	-8.731	74.000	36.536	PK
3			5357.040	71.146	34.594	-2.854	74.000	36.553	PK

Note: Measure Level (dB $\mu$ V/m) = Reading Level (dB $\mu$ V) + Factor (dB)

Factor (dB) = Cable Loss (dB) + Antenna Factor (dB/m).

Site: AC1	Time: 2014/07/18 - 16:38
Limit: FCC_Part15.209_RE(3m)	Engineer: Roy Cheng
Probe: BBHA9120D_1-18GHz	Polarity: Horizontal
EUT: WIFI dual band 4 GE LAN GPON HGU	Power: AC 120V/60Hz
Test Mode: Transmit by 802.11ac-VHT80 at channel 5530MHz Ant 0+1+2+3	

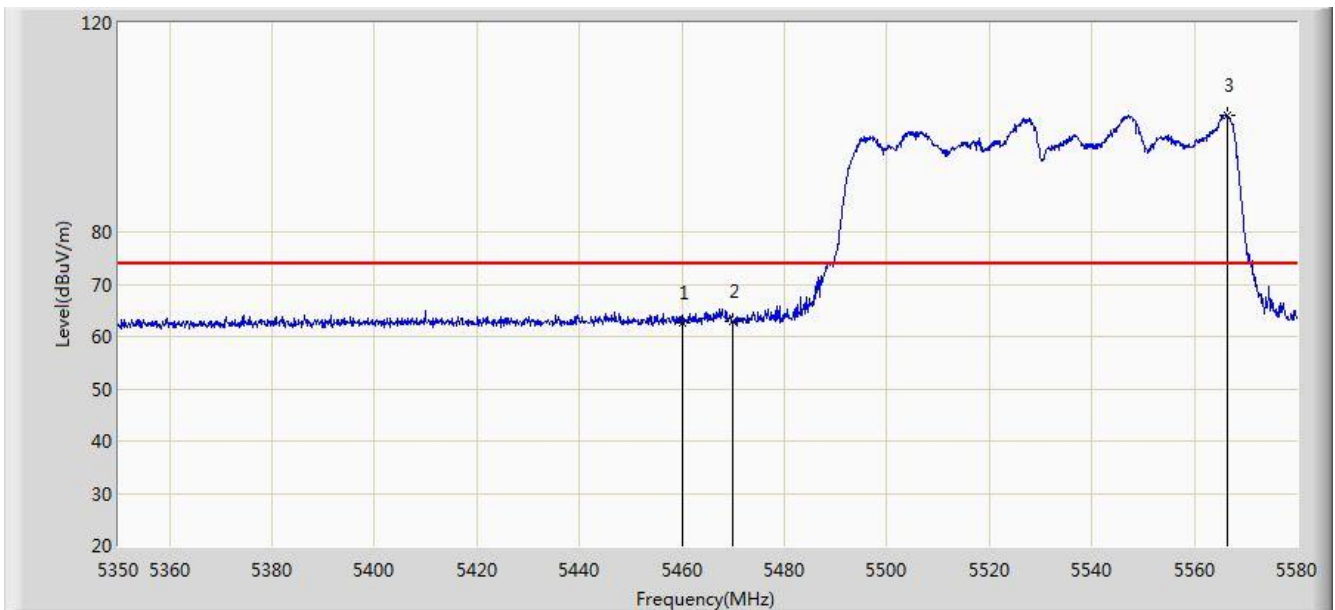

No	Flag	Mark	Frequency (MHz)	Measure Level (dBuV/m)	Reading Level (dBuV)	Over Limit (dB)	Limit (dBuV/m)	Factor (dB)	Type
1			5460.000	62.521	25.711	-11.479	74.000	36.810	PK
2			5470.000	62.927	26.102	-11.073	74.000	36.825	PK
3		*	5566.315	102.263	65.337	N/A	N/A	36.926	PK

Note: Measure Level (dB $\mu$ V/m) = Reading Level (dB $\mu$ V) + Factor (dB)

Factor (dB) = Cable Loss (dB) + Antenna Factor (dB/m).



Site: AC1	Time: 2014/07/18 - 16:41
Limit: FCC_Part15.209_RE(3m)	Engineer: Roy Cheng
Probe: BBHA9120D_1-18GHz	Polarity: Horizontal
EUT: WIFI dual band 4 GE LAN GPON HGU	Power: AC 120V/60Hz
Test Mode: Transmit by 802.11ac-VHT80 at channel 5530MHz Ant 0+1+2+3	

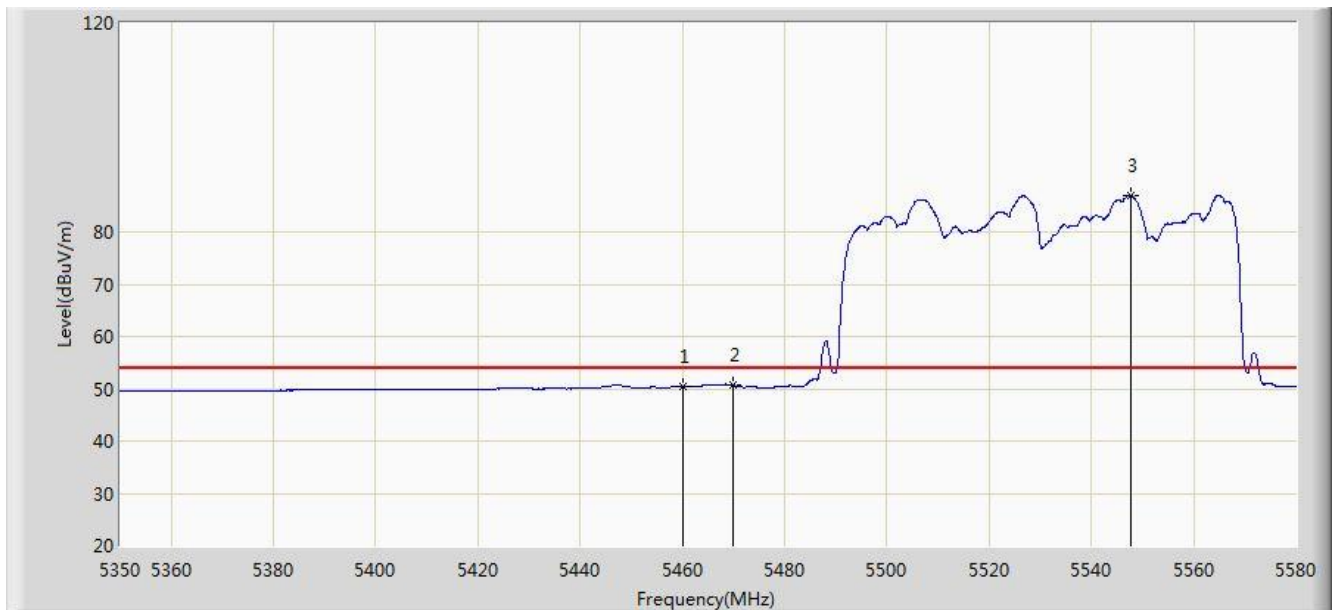

No	Flag	Mark	Frequency (MHz)	Measure Level (dBuV/m)	Reading Level (dBuV)	Over Limit (dB)	Limit (dBuV/m)	Factor (dB)	Type
1			5460.000	50.433	13.623	-3.567	54.000	36.810	AV
2			5470.000	50.622	13.797	-3.378	54.000	36.825	AV
3		*	5547.685	87.009	50.079	N/A	N/A	36.930	AV

Note: Measure Level (dB $\mu$ V/m) = Reading Level (dB $\mu$ V) + Factor (dB)

Factor (dB) = Cable Loss (dB) + Antenna Factor (dB/m).

Site: AC1	Time: 2014/07/18 - 16:51
Limit: FCC_Part15.209_RE(3m)	Engineer: Roy Cheng
Probe: BBHA9120D_1-18GHz	Polarity: Vertical
EUT: WIFI dual band 4 GE LAN GPON HGU	Power: AC 120V/60Hz
Test Mode: Transmit by 802.11ac-VHT80 at channel 5530MHz Ant 0+1+2+3	

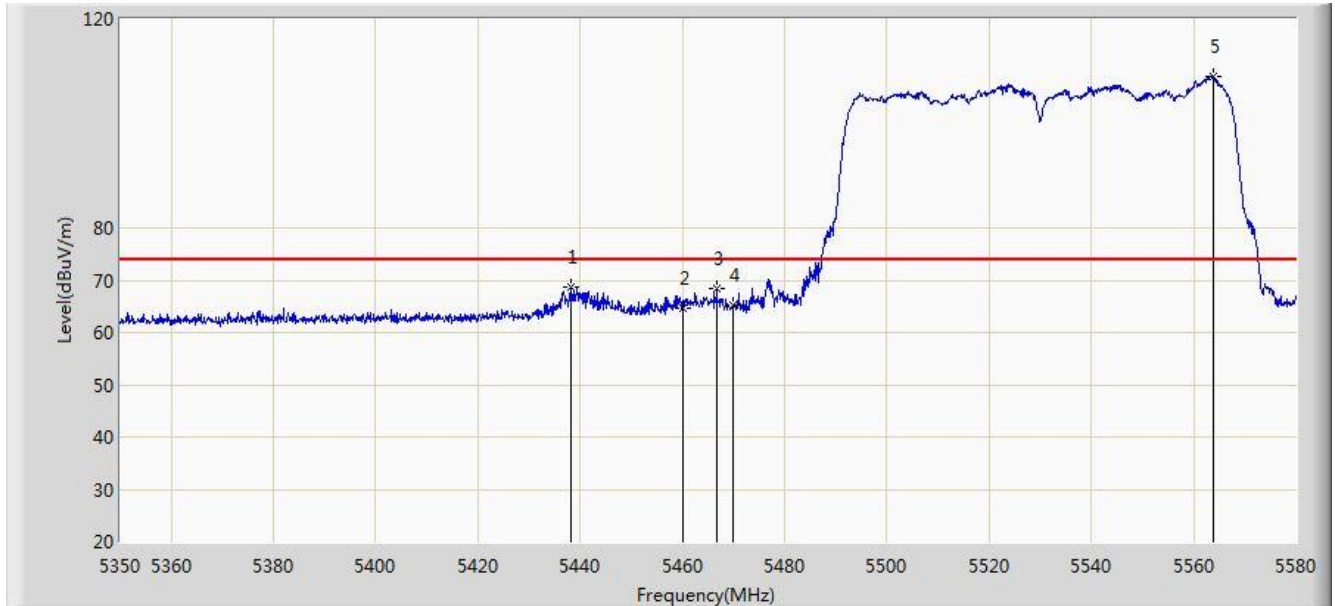

No	Flag	Mark	Frequency (MHz)	Measure Level (dBuV/m)	Reading Level (dBuV)	Over Limit (dB)	Limit (dBuV/m)	Factor (dB)	Type
1			5438.320	68.648	31.884	-5.352	74.000	36.764	PK
2			5460.000	64.772	27.962	-9.228	74.000	36.810	PK
3			5466.725	68.546	31.726	-5.454	74.000	36.820	PK
4			5470.000	65.113	28.288	-8.887	74.000	36.825	PK
5		*	5563.900	108.871	71.946	34.871	74.000	36.925	PK

Note: Measure Level (dB $\mu$ V/m) = Reading Level (dB $\mu$ V) + Factor (dB)

Factor (dB) = Cable Loss (dB) + Antenna Factor (dB/m).

Site: AC1	Time: 2014/07/18 - 16:47
Limit: FCC_Part15.209_RE(3m)	Engineer: Roy Cheng
Probe: BBHA9120D_1-18GHz	Polarity: Vertical
EUT: WIFI dual band 4 GE LAN GPON HGU	Power: AC 120V/60Hz
Test Mode: Transmit by 802.11ac-VHT80 at channel 5530MHz Ant 0+1+2+3	

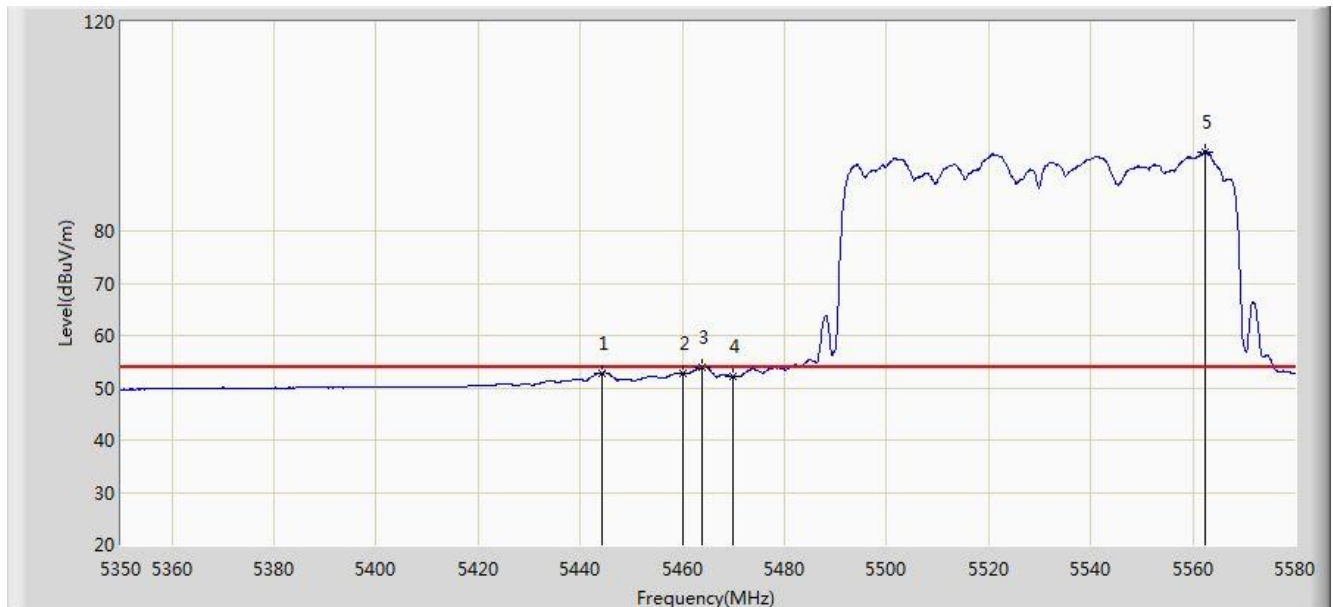

No	Flag	Mark	Frequency (MHz)	Measure Level (dBuV/m)	Reading Level (dBuV)	Over Limit (dB)	Limit (dBuV/m)	Factor (dB)	Type
1			5444.300	52.841	16.063	-1.159	54.000	36.778	AV
2			5460.000	52.776	15.966	-1.224	54.000	36.810	AV
3			5463.965	53.849	15.033	-0.151	54.000	36.816	AV
4			5470.000	52.085	15.260	-1.915	54.000	36.825	AV
5		*	5562.405	95.153	58.228	N/A	N/A	36.925	AV

Note: Measure Level (dB $\mu$ V/m) = Reading Level (dB $\mu$ V) + Factor (dB)

Factor (dB) = Cable Loss (dB) + Antenna Factor (dB/m).

## 7.10. AC Conducted Emissions Measurement

### 7.10.1. Test Limit

FCC Part 15 Subpart C Paragraph 15.207		
Frequency (MHz)	QP (dB $\mu$ V)	AV (dB $\mu$ V)
0.15 - 0.50	66 - 56	56 - 46
0.50 - 5.0	56	46
5.0 - 30	60	50

Note 1: The lower limit shall apply at the transition frequencies.

Note 2: The limit decreases linearly with the logarithm of the frequency in the range 0.15MHz to 0.5MHz.

### 7.10.2. Test Procedure

The EUT was setup according to ANSI C63.4, 2009 and tested according to KDB 789033 for compliance to FCC 47CFR 15.247 requirements. The EUT was placed on a platform of nominal size, 1 m by 1.5 m, raised 80 cm above the conducting ground plane. The vertical conducting plane was located 40 cm to the rear of the EUT. All other surfaces of EUT were at least 80 cm from any other grounded conducting surface. The EUT and simulators are connected to the main power through a line impedance stabilization network (LISN). The LISN provides a 50 ohm /50uH coupling impedance for the measuring equipment. The peripheral devices are also connected to the main power through a LISN. (Please refer to the block diagram of the test setup and photographs) Each current-carrying conductor of the EUT power cord, except the ground (safety) conductor, was individually connected through a LISN to the input power source.

The excess length of the power cord between the EUT and the LISN receptacle were folded back and forth at the center of the lead to form a bundle not exceeding 40 cm in length.

Conducted emissions were investigated over the frequency range from 0.15MHz to 30MHz using a receiver bandwidth of 9 kHz.

### 7.10.3. Test Setup

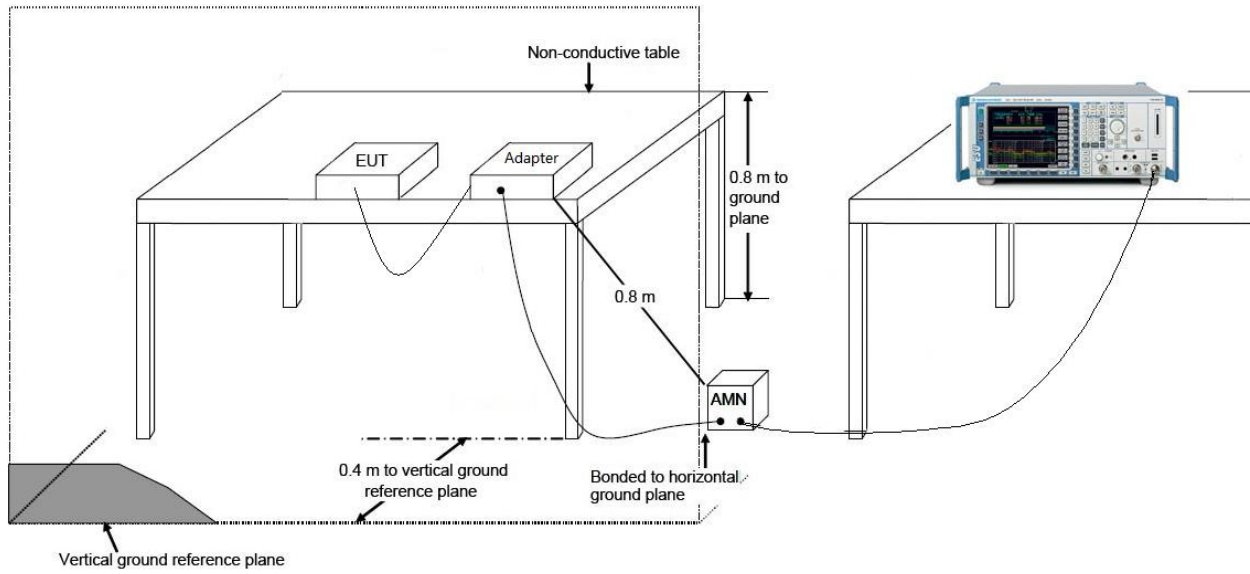

**7.10.4. Test Result**

Site: SR2	Time: 2015/01/31 - 19:16
Limit: FCC_Part15.207_CE_ClassB	Engineer: Roy Cheng
Probe: ENV216_101683_Filter On	Polarity: Line
EUT: WIFI dual band 4 GE LAN GPON HGU	Power: AC 120V/60Hz
Note: Mode 1	

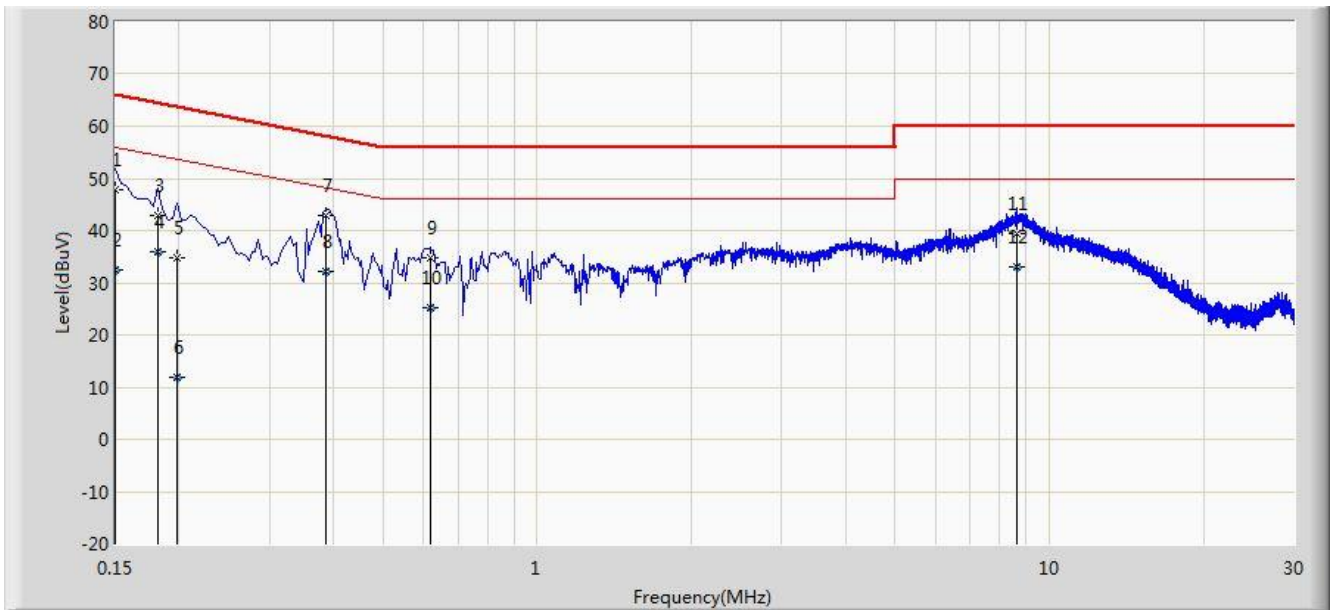

No	Flag	Mark	Frequency (MHz)	Measure Level (dBuV)	Reading Level (dBuV)	Over Limit (dB)	Limit (dBuV)	Factor (dB)	Type
1			0.150	47.724	36.582	-18.276	66.000	11.142	QP
2			0.150	32.331	21.189	-23.669	56.000	11.142	AV
3			0.182	42.838	32.795	-21.556	64.394	10.042	QP
4			0.182	35.867	25.825	-18.527	54.394	10.042	AV
5			0.198	34.756	24.742	-28.938	63.694	10.015	QP
6			0.198	11.826	1.811	-41.868	53.694	10.015	AV
7		*	0.386	42.872	32.770	-15.277	58.149	10.102	QP
8			0.386	32.098	21.996	-16.051	48.149	10.102	AV
9			0.618	34.905	24.783	-21.095	56.000	10.121	QP
10			0.618	25.260	15.139	-20.740	46.000	10.121	AV
11			8.630	39.359	29.161	-20.641	60.000	10.199	QP
12			8.630	32.975	22.777	-17.025	50.000	10.199	AV

Note: Measure Level (dBμV) = Reading Level (dBμV) + Factor (dB)

Factor (dB) = Cable Loss (dB) + LISN Factor (dB)

Site: SR2	Time: 2015/01/31 - 19:20
Limit: FCC_Part15.207_CE_ClassB	Engineer: Roy Cheng
Probe: ENV216_101683_Filter On	Polarity: Neutral
EUT: WIFI dual band 4 GE LAN GPON HGU	Power: AC 120V/60Hz
Note: Mode 1	

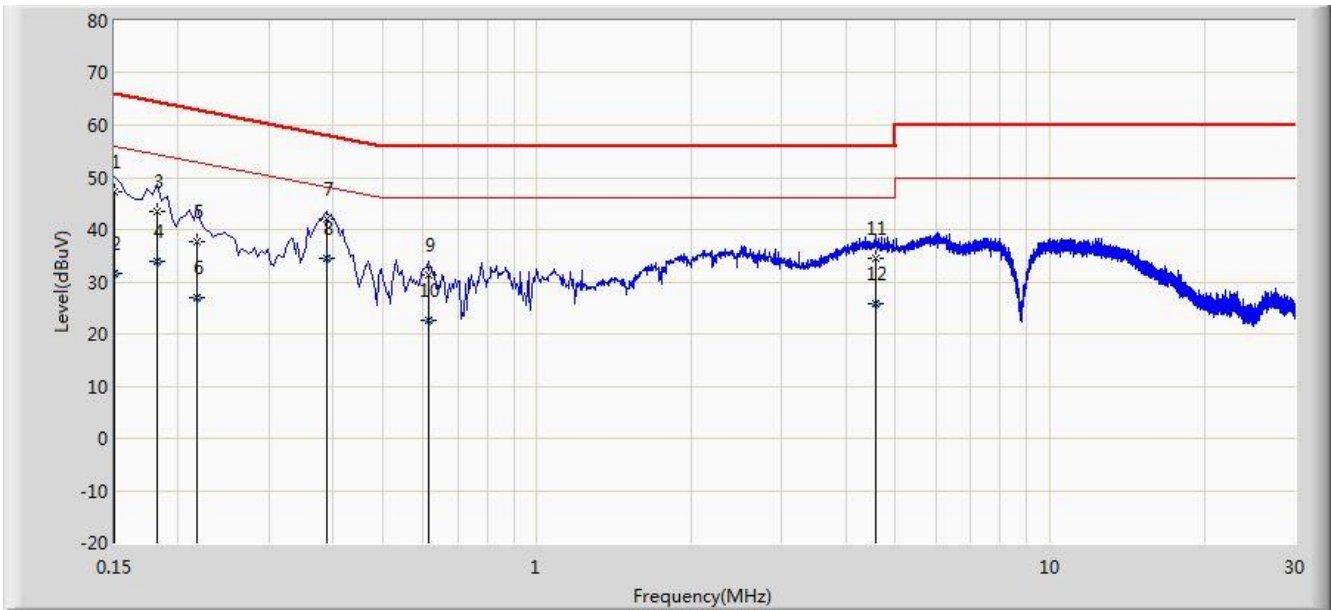

No	Flag	Mark	Frequency (MHz)	Measure Level (dBuV)	Reading Level (dBuV)	Over Limit (dB)	Limit (dBuV)	Factor (dB)	Type
1			0.150	47.154	36.012	-18.846	66.000	11.142	QP
2			0.150	31.458	20.316	-24.542	56.000	11.142	AV
3			0.182	43.519	33.476	-20.875	64.394	10.042	QP
4			0.182	34.031	23.988	-20.363	54.394	10.042	AV
5			0.218	37.691	27.710	-25.204	62.895	9.981	QP
6			0.218	26.953	16.972	-25.942	52.895	9.981	AV
7			0.390	42.100	31.995	-15.964	58.064	10.105	QP
8		*	0.390	34.369	24.265	-13.694	48.064	10.105	AV
9			0.614	31.375	21.251	-24.625	56.000	10.124	QP
10			0.614	22.489	12.366	-23.511	46.000	10.124	AV
11			4.586	34.458	24.453	-21.542	56.000	10.005	QP
12			4.586	25.669	15.664	-20.331	46.000	10.005	AV

Note: Measure Level (dBμV) = Reading Level (dBμV) + Factor (dB)

Factor (dB) = Cable Loss (dB) + LISN Factor (dB)

## 8. CONCLUSION

The data collected relate only the item(s) tested and show that the **WIFI dual band 4 GE LAN GPON HGU FCC ID: 2ABLK-8X4G-2V2** is in compliance with Part 15E of the FCC Rules.



### Output Power Measurement

Test Mode	Data Rate (Mbps)	Channel No.	Freq. (MHz)	Ant 0 Average Power (dBm)	Ant 1 Average Power (dBm)	Ant 2 Average Power (dBm)	Ant 3 Average Power (dBm)	Total Average Power (dBm)	Limit (dBm)	Result
11a	6	36	5180	16.02	16.61	16.03	16.34	22.28	≤27.96	Pass
11a	6	44	5220	18.11	18.12	17.82	18.25	24.10	≤27.96	Pass
11a	6	48	5240	17.81	18.22	17.81	18.02	23.99	≤27.96	Pass
11a	6	52	5260	14.54	14.30	13.67	14.46	20.28	≤22.22	Pass
11a	6	60	5300	14.57	14.45	13.83	14.72	20.43	≤22.22	Pass
11a	6	64	5320	14.62	14.50	14.08	14.54	20.46	≤22.22	Pass
11a	6	100	5500	14.29	13.74	13.19	13.88	19.81	≤21.62	Pass
11a	6	120	5600	14.18	13.96	12.67	13.77	19.70	≤21.62	Pass
11a	6	140	5700	13.26	13.74	12.02	12.54	18.96	≤21.62	Pass
11a	6	149	5745	20.63	20.93	20.84	21.46	27.00	≤27.30	Pass
11a	6	157	5785	20.18	20.53	20.91	21.68	26.88	≤27.30	Pass
11a	6	165	5825	20.46	20.73	21.00	21.37	26.92	≤27.30	Pass

Note: The Total Average Power (dBm) =  $10 \cdot \log\{10^{(\text{Ant 0 Average Power} / 10)} + 10^{(\text{Ant 1 Average Power} / 10)} + 10^{(\text{Ant 2 Average Power} / 10)} + 10^{(\text{Ant 3 Average Power} / 10)}\}$ .

### Power Spectral Density Measurement

Test Mode	Data Rate (Mbps)	Channel No.	Freq. (MHz)	Ant 0 PSD (dBm/MHz)	Ant 1 PSD (dBm/MHz)	Ant 2 PSD (dBm/MHz)	Ant 3 PSD (dBm/MHz)	Duty Cycle (%)	Total PSD (dBm/MHz)	Limit (dBm/MHz)	Result
11a	6	36	5180	3.68	3.94	4.08	4.06	98.9	9.96	≤14.96	Pass
11a	6	44	5220	5.00	6.43	6.12	5.96	98.9	11.93	≤14.96	Pass
11a	6	48	5240	5.81	4.17	6.21	5.89	98.9	11.61	≤14.96	Pass
11a	6	52	5260	1.59	2.16	2.07	2.47	98.9	8.10	≤9.22	Pass
11a	6	60	5300	1.72	1.96	2.01	1.05	98.9	7.72	≤9.22	Pass
11a	6	64	5320	1.62	1.66	1.79	0.99	98.9	7.55	≤9.22	Pass
11a	6	100	5500	1.92	2.05	1.34	1.08	98.9	7.64	≤8.62	Pass
11a	6	120	5600	2.57	1.93	2.59	1.29	98.9	8.15	≤8.62	Pass
11a	6	140	5700	1.08	1.86	-0.14	-0.81	98.9	6.64	≤8.62	Pass

Note: When EUT duty cycle < 98%, the total PSD =  $10 \cdot \log\{10^{(\text{Ant 0 PSD}/10)} + 10^{(\text{Ant 1 PSD}/10)} + 10^{(\text{Ant 2 PSD}/10)} + 10^{(\text{Ant 3 PSD}/10)}\} + 10 \cdot \log(1/\text{duty cycle})$

## 802.11a Power Spectral Density - Ant 0 / Ant 0 + 1 + 2 + 3

Channel 36 (5180MHz)

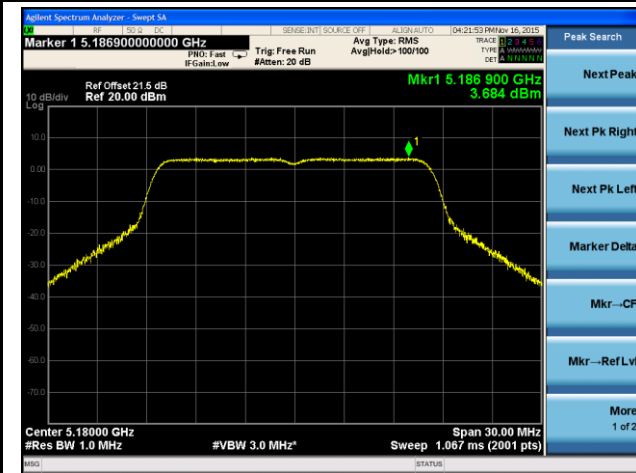

Channel 44 (5220MHz)

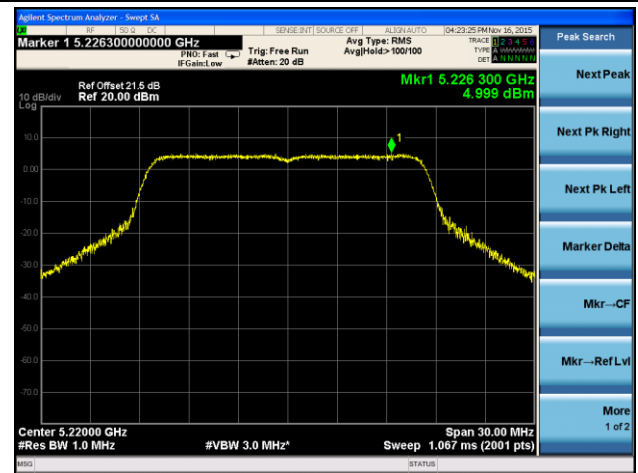

Channel 48 (5240MHz)

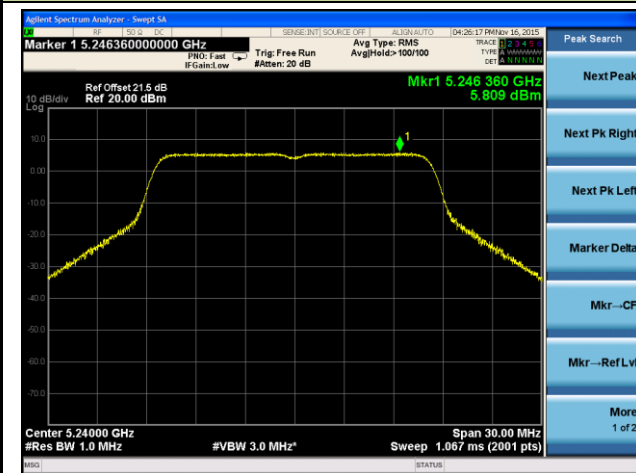

Channel 52 (5260MHz)

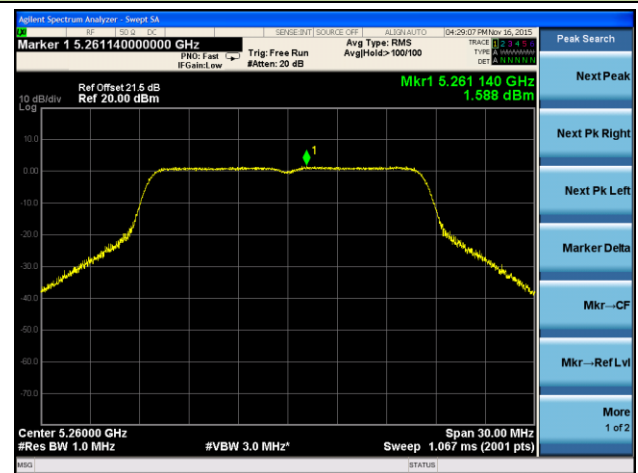

Channel 60 (5300MHz)

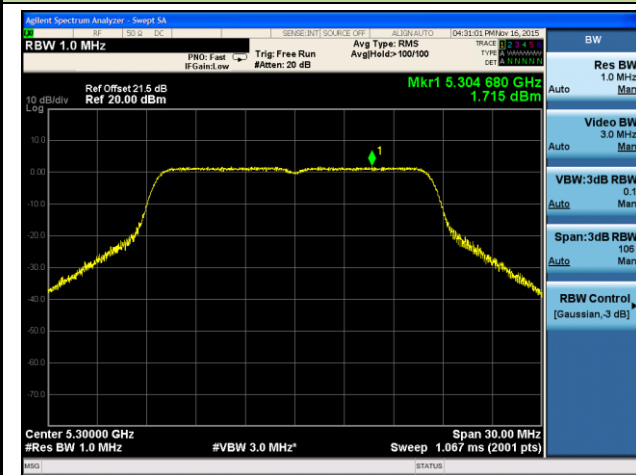

Channel 64 (5320MHz)

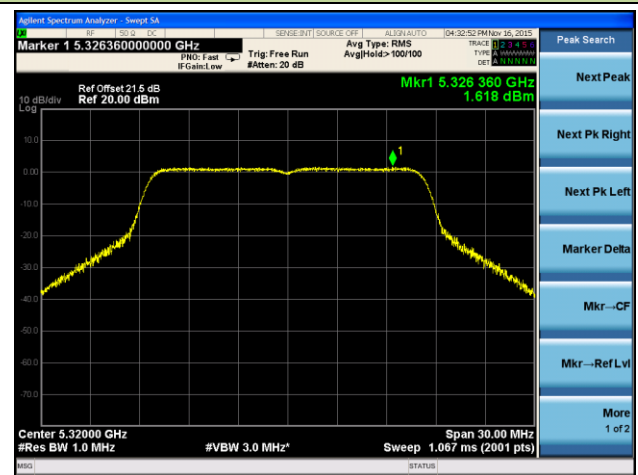

### Channel 100 (5500MHz)

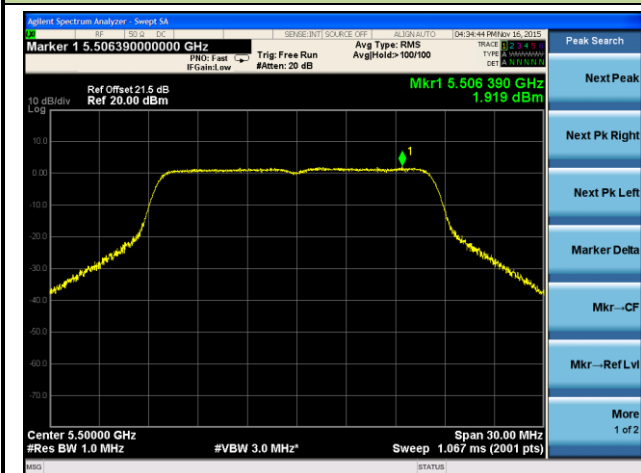

### Channel 120 (5600MHz)

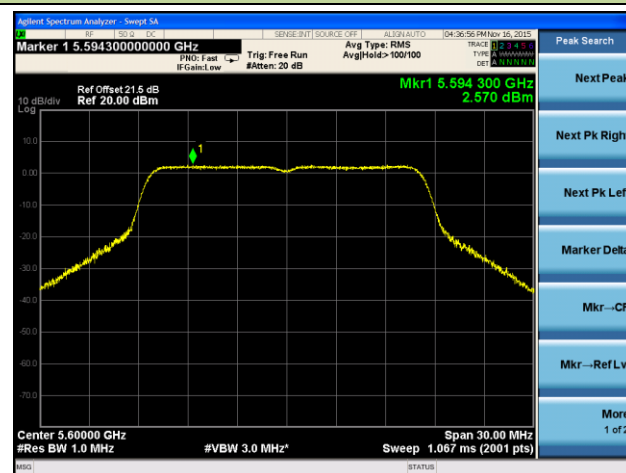

### Channel 140 (5700MHz)

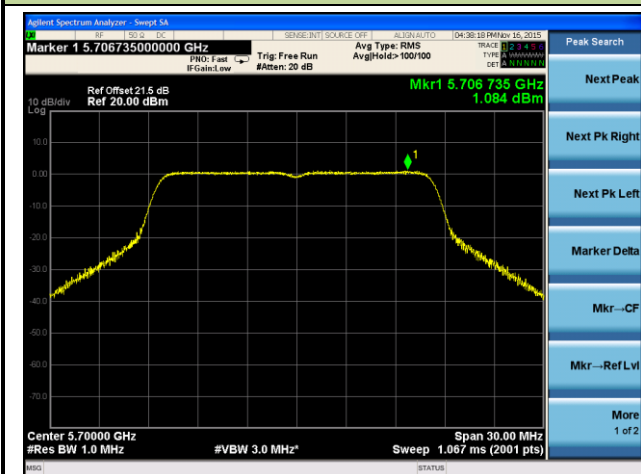

## 802.11a Power Spectral Density - Ant 1 / Ant 0 + 1 + 2 + 3

Channel 36 (5180MHz)

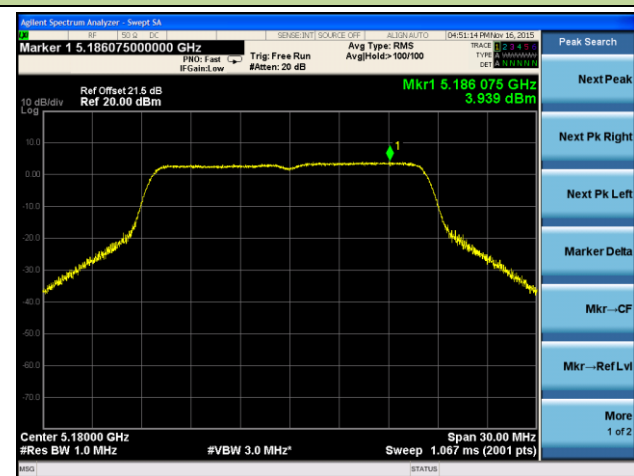

Channel 44 (5220MHz)

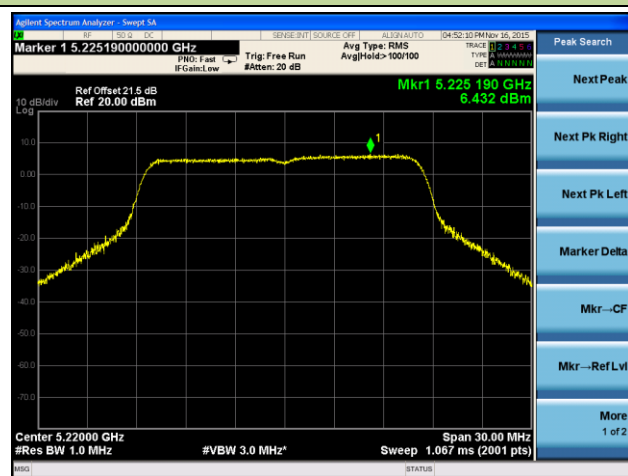

Channel 48 (5240MHz)

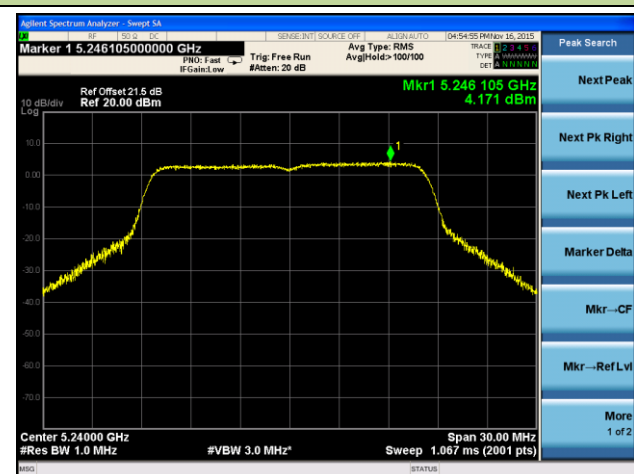

Channel 52 (5260MHz)

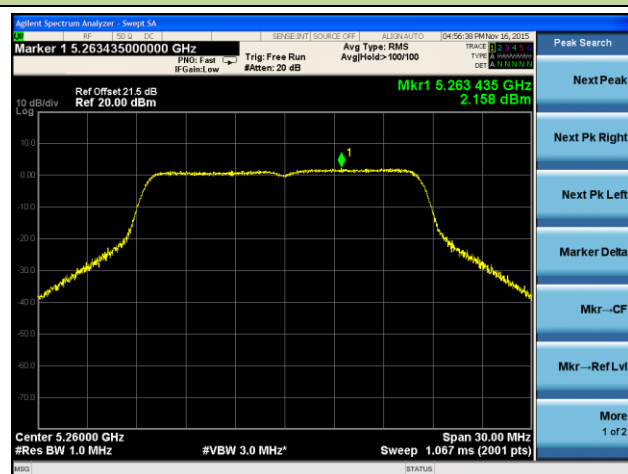

Channel 60 (5300MHz)

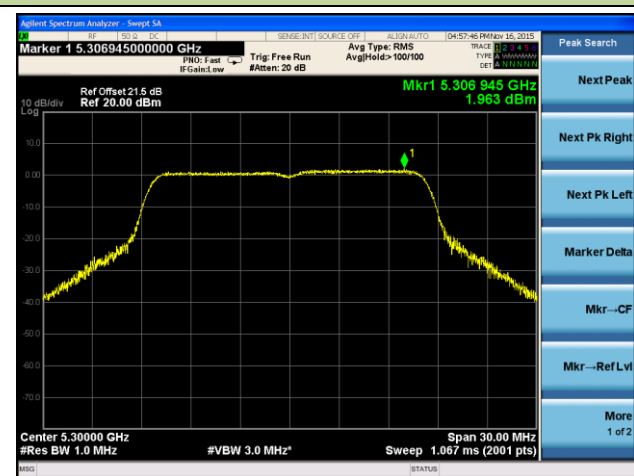

Channel 64 (5320MHz)

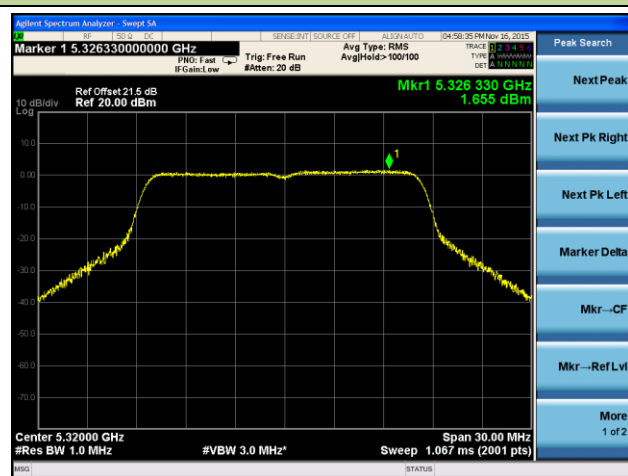

### Channel 100 (5500MHz)

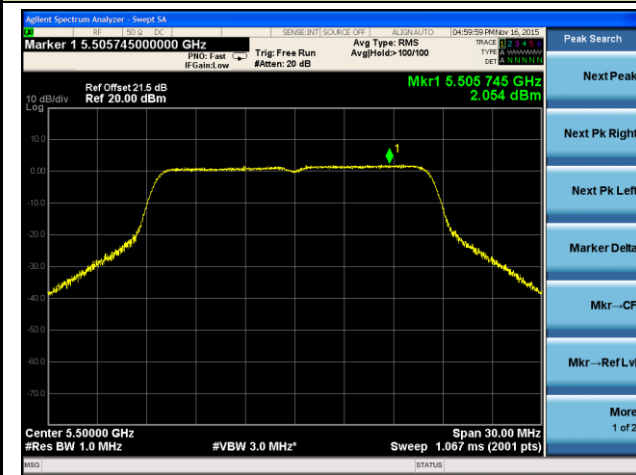

### Channel 120 (5600MHz)

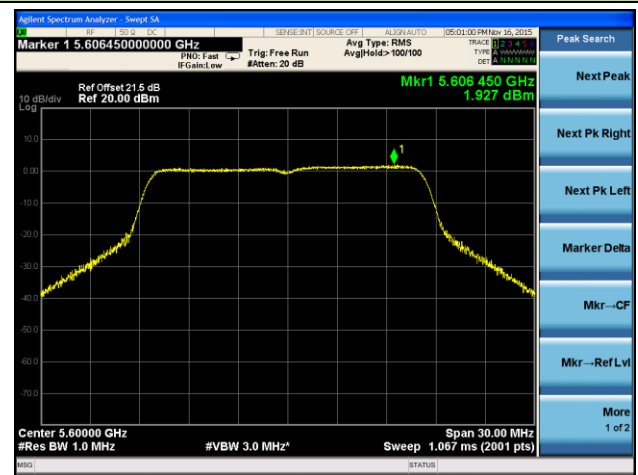

### Channel 140 (5700MHz)

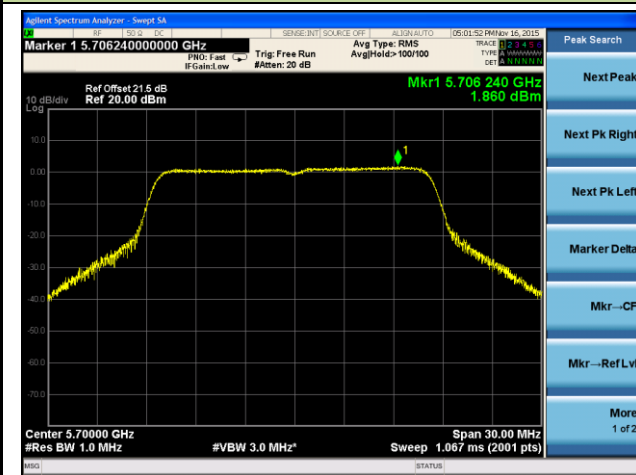

## 802.11a Power Spectral Density - Ant 2 / Ant 0 + 1 + 2 + 3

Channel 36 (5180MHz)

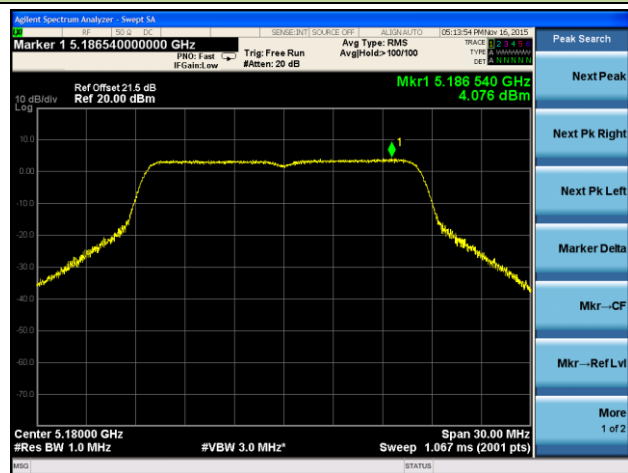

Channel 44 (5220MHz)

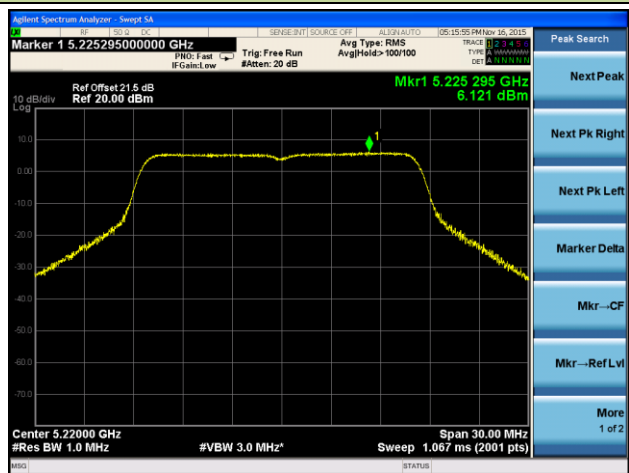

Channel 48 (5240MHz)

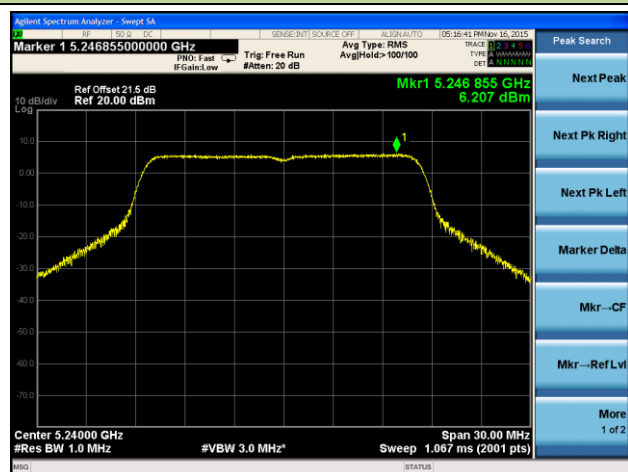

Channel 52 (5260MHz)

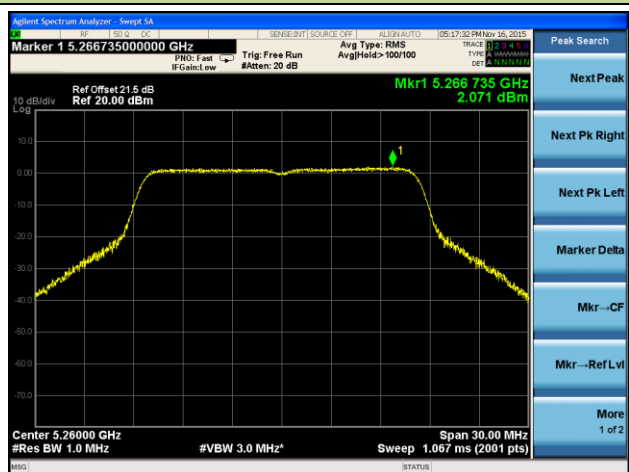

Channel 60 (5300MHz)

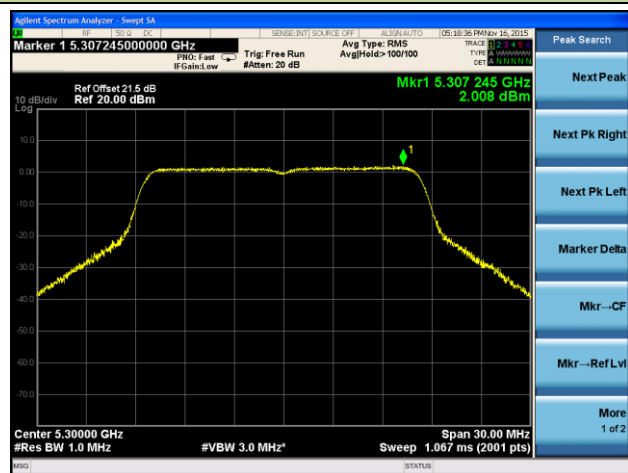

Channel 64 (5320MHz)

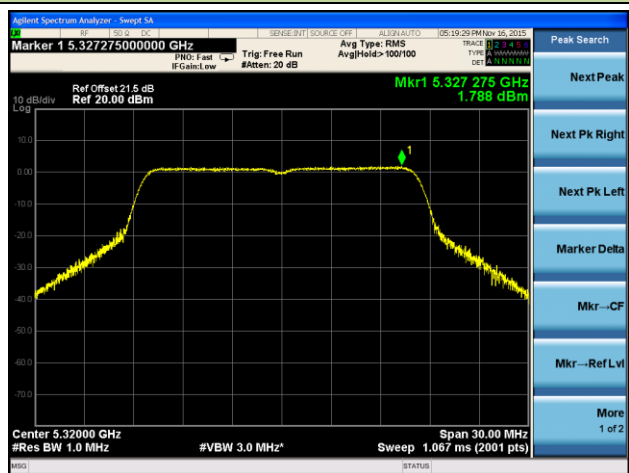

### Channel 100 (5500MHz)

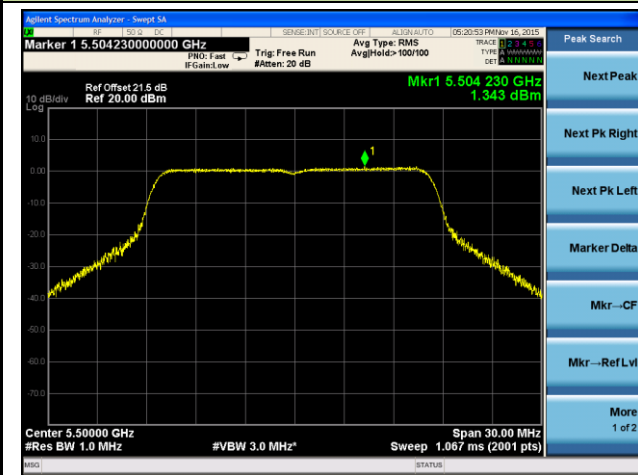

### Channel 120 (5600MHz)

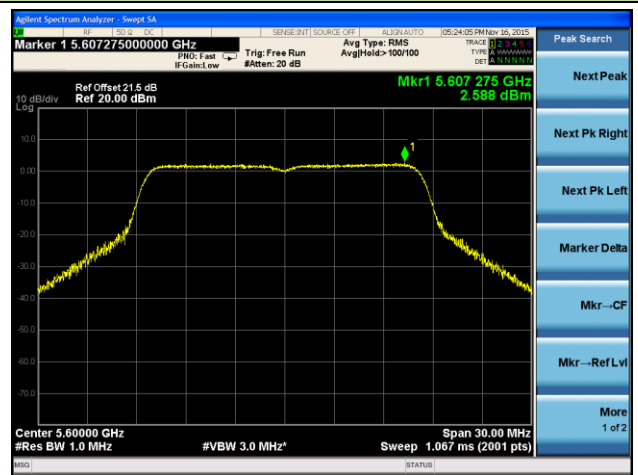

### Channel 140 (5700MHz)

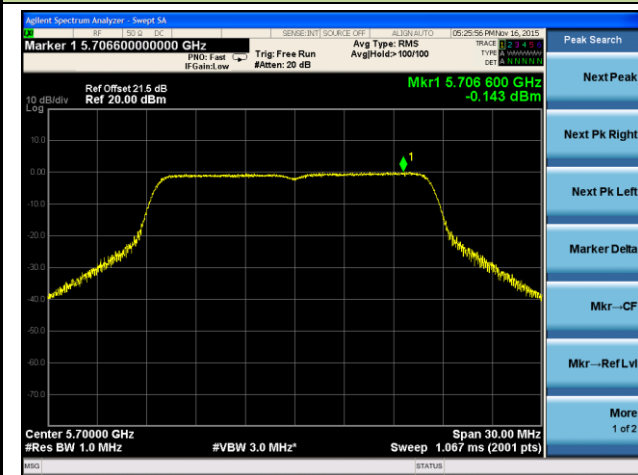



## 802.11a Power Spectral Density - Ant 3 / Ant 0 + 1 + 2 + 3

Channel 36 (5180MHz)

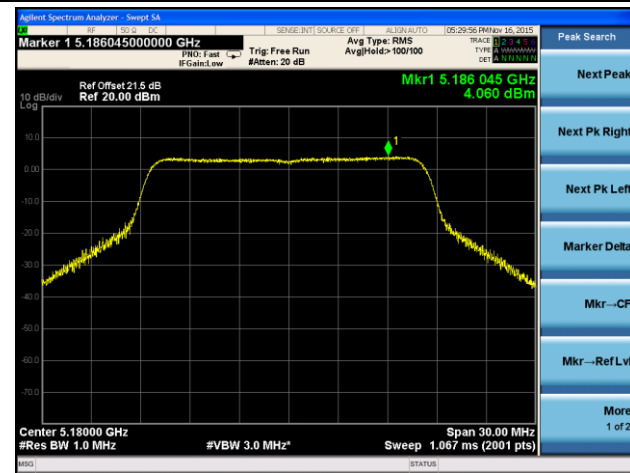

Channel 44 (5220MHz)

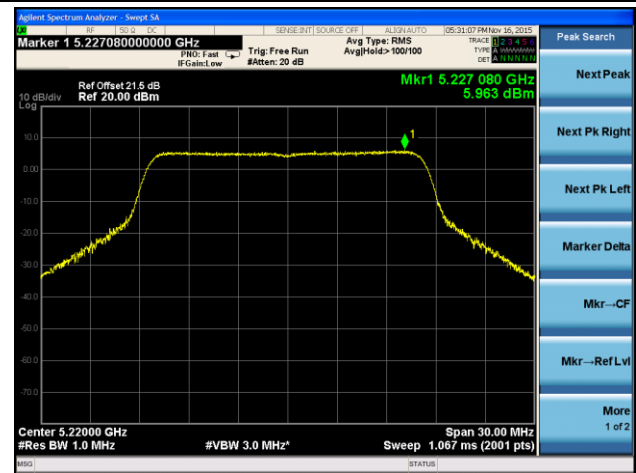

Channel 48 (5240MHz)

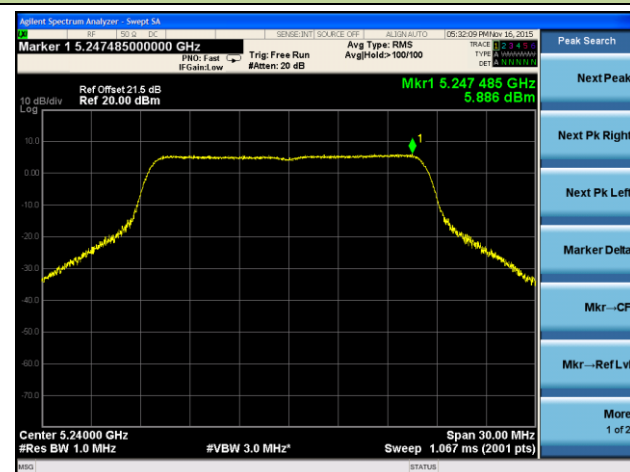

Channel 52 (5260MHz)

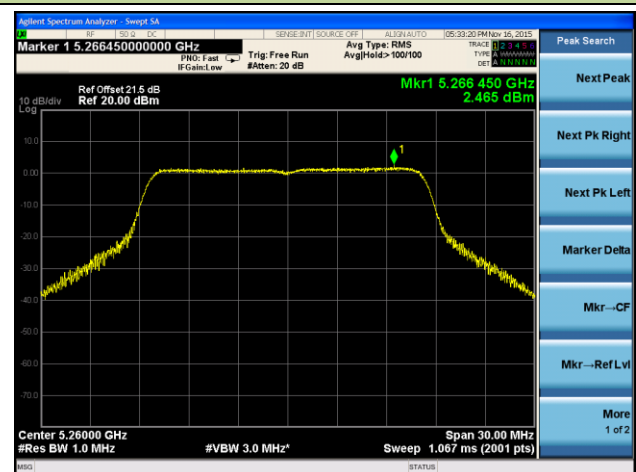

Channel 60 (5300MHz)

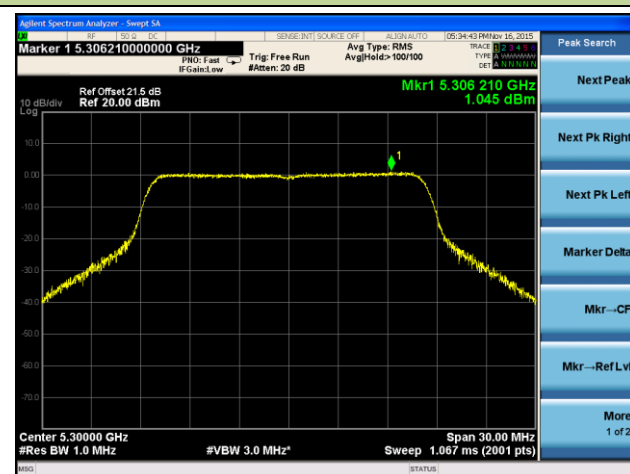

Channel 64 (5320MHz)

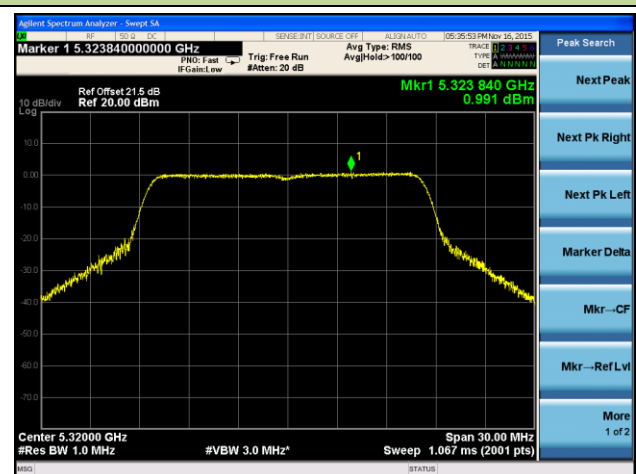

### Channel 100 (5500MHz)

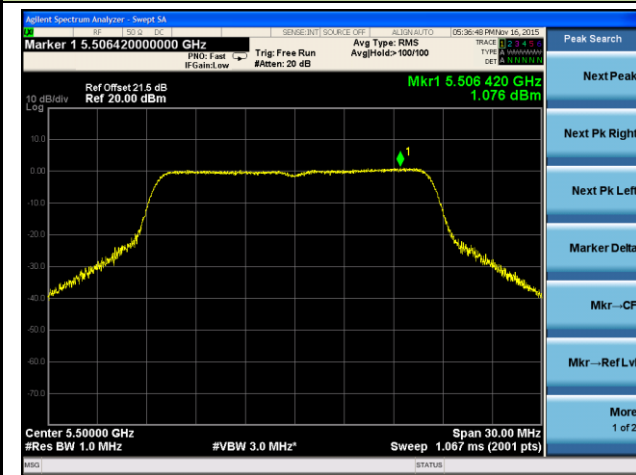

### Channel 120 (5600MHz)

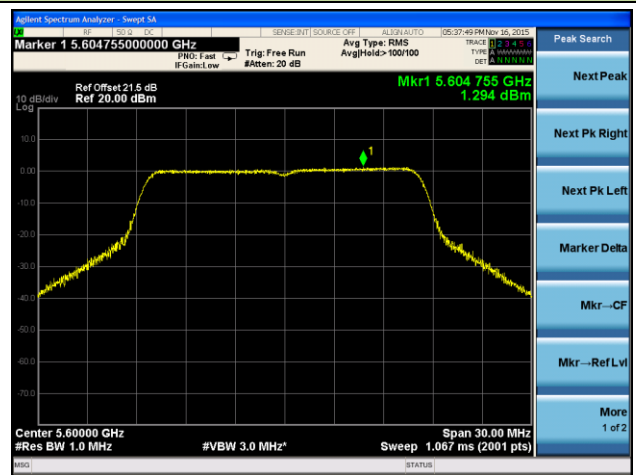

### Channel 140 (5700MHz)

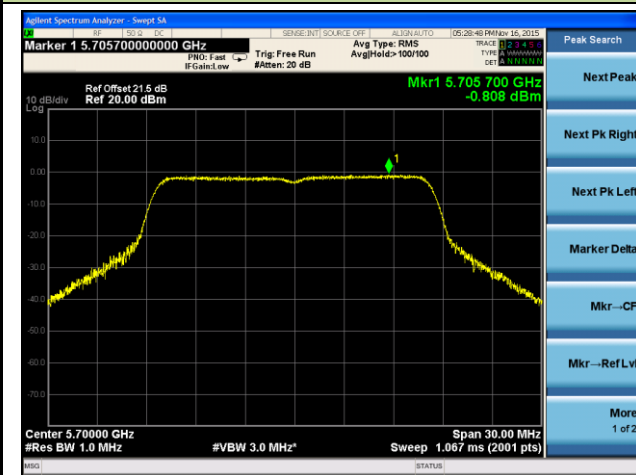

### Radiated Spurious Emission Measurement

Test Mode:	802.11a	Test Site:	AC1
Test Channel:	36	Test Engineer:	Roy Cheng
Remark:	1. Average measurement was not performed if peak level lower than average limit. 2. Other frequency was 20dB below limit line within 1-18GHz, there is not show in the report.		

Mark	Frequency (MHz)	Reading Level (dBμV)	Factor (dB)	Measure Level (dBμV/m)	Limit (dBμV/m)	Margin (dB)	Detector	Polarization
	7356.5	38.6	8.0	46.6	74.0	-27.4	Peak	Horizontal
*	10358.3	42.5	12.2	54.7	88.2	-33.5	Peak	Horizontal
	11526.4	38.1	12.7	50.8	74.0	-23.2	Peak	Horizontal
*	13426.4	37.9	13.6	51.5	88.2	-36.7	Peak	Horizontal
	8143.4	38.9	8.5	47.4	74.0	-26.6	Peak	Vertical
*	10358.2	47.0	12.2	59.2	88.2	-29.0	Peak	Vertical
	11523.4	38.4	12.7	51.1	74.0	-22.9	Peak	Vertical
*	12742.5	37.8	11.7	49.5	88.2	-38.7	Peak	Vertical

Note 1: "\*" is not in restricted band, its limit is -27dBm/MHz. At a distance of 3 meters, the field strength limit in dBμV/m can be determined by adding a "conversion" factor of 95.2dB to the EIRP limit of -27dBm/MHz to obtain the limit for out of band spurious emissions.

Note 2: Measure Level (dBμV/m) = Reading Level (dBμV) + Factor (dB)

Factor (dB) = Cable Loss (dB) + Antenna Factor (dB/m) - Pre\_Amplifier Gain (dB)

Test Mode:	802.11a	Test Site:	AC1
Test Channel:	44	Test Engineer:	Roy Cheng
Remark:	1. Average measurement was not performed if peak level lower than average limit. 2. Other frequency was 20dB below limit line within 1-18GHz, there is not show in the report.		

Mark	Frequency (MHz)	Reading Level (dBμV)	Factor (dB)	Measure Level (dBμV/m)	Limit (dBμV/m)	Margin (dB)	Detector	Polarization
	7625.4	38.3	8.0	46.3	74.0	-27.7	Peak	Horizontal
*	10434.7	45.7	12.0	57.7	88.2	-30.5	Peak	Horizontal
	15657.3	32.4	12.0	44.4	54.0	-9.6	Average	Horizontal
	15662.2	47.2	12.0	59.2	74.0	-14.8	Peak	Horizontal
*	16253.5	39.6	12.7	52.3	88.2	-35.9	Peak	Horizontal
	7653.2	39.5	8.0	47.5	74.0	-26.5	Peak	Vertical
*	10443.2	48.6	12.0	60.6	88.2	-27.6	Peak	Vertical
	15653.6	41.6	12.0	53.6	74.0	-20.4	Peak	Vertical
*	16253.2	40.0	12.7	52.7	88.2	-35.5	Peak	Vertical

Note 1: "\*" is not in restricted band, its limit is -27dBm/MHz. At a distance of 3 meters, the field strength limit in dBμV/m can be determined by adding a "conversion" factor of 95.2dB to the EIRP limit of -27dBm/MHz to obtain the limit for out of band spurious emissions.

Note 2: Measure Level (dBμV/m) = Reading Level (dBμV) + Factor (dB)

Factor (dB) = Cable Loss (dB) + Antenna Factor (dB/m) - Pre\_Amplifier Gain (dB)

Test Mode:	802.11a	Test Site:	AC1
Test Channel:	48	Test Engineer:	Roy Cheng
Remark:	1. Average measurement was not performed if peak level lower than average limit. 2. Other frequency was 20dB below limit line within 1-18GHz, there is not show in the report.		

Mark	Frequency (MHz)	Reading Level (dB $\mu$ V)	Factor (dB)	Measure Level (dB $\mu$ V/m)	Limit (dB $\mu$ V/m)	Margin (dB)	Detector	Polarization
	9155.3	36.8	9.8	46.6	74.0	-27.4	Peak	Horizontal
*	10477.2	45.1	12.2	57.3	88.2	-30.9	Peak	Horizontal
	15719.4	31.7	11.8	43.5	54.0	-10.5	Average	Horizontal
	15721.8	47.0	11.8	58.8	74.0	-15.2	Peak	Horizontal
*	16253.2	40.6	12.7	53.3	88.2	-34.9	Peak	Horizontal
	7324.7	37.7	8.0	45.7	74.0	-28.3	Peak	Vertical
*	10477.3	49.8	12.2	62.0	88.2	-26.2	Peak	Vertical
	11425.7	35.7	12.7	48.4	74.0	-25.6	Peak	Vertical
*	12756.7	36.6	11.7	48.3	88.2	-39.9	Peak	Vertical

Note 1: "\*" is not in restricted band, its limit is -27dBm/MHz. At a distance of 3 meters, the field strength limit in dB $\mu$ V/m can be determined by adding a "conversion" factor of 95.2dB to the EIRP limit of -27dBm/MHz to obtain the limit for out of band spurious emissions.

Note 2: Measure Level (dB $\mu$ V/m) = Reading Level (dB $\mu$ V) + Factor (dB)

Factor (dB) = Cable Loss (dB) + Antenna Factor (dB/m) - Pre\_Amplifier Gain (dB)

Test Mode:	802.11a	Test Site:	AC1
Test Channel:	52	Test Engineer:	Roy Cheng
Remark:	1. Average measurement was not performed if peak level lower than average limit. 2. Other frequency was 20dB below limit line within 1-18GHz, there is not show in the report.		

Mark	Frequency (MHz)	Reading Level (dBμV)	Factor (dB)	Measure Level (dBμV/m)	Limit (dBμV/m)	Margin (dB)	Detector	Polarization
*	7046.2	43.7	7.1	50.8	88.2	-37.4	Peak	Horizontal
*	7832.3	45.5	8.4	53.9	88.2	-34.3	Peak	Horizontal
	9066.1	41.6	9.1	50.7	74.0	-23.3	Peak	Horizontal
	10808.6	40.5	12.7	53.2	74.0	-20.8	Peak	Horizontal
*	7016.3	45.1	6.9	52.0	88.2	-36.2	Peak	Vertical
*	7963.2	45.0	8.6	53.6	88.2	-34.6	Peak	Vertical
	9167.3	41.4	9.9	51.3	74.0	-22.7	Peak	Vertical
	10698.2	39.6	12.4	52.0	74.0	-22.0	Peak	Vertical

Note 1: "\*" is not in restricted band, its limit is -27dBm/MHz. At a distance of 3 meters, the field strength limit in dBμV/m can be determined by adding a "conversion" factor of 95.2dB to the EIRP limit of -27dBm/MHz to obtain the limit for out of band spurious emissions.

Note 2: Measure Level (dBμV/m) = Reading Level (dBμV) + Factor (dB)

Factor (dB) = Cable Loss (dB) + Antenna Factor (dB/m) - Pre\_Amplifier Gain (dB)

Test Mode:	802.11a	Test Site:	AC1
Test Channel:	60	Test Engineer:	Roy Cheng
Remark:	1. Average measurement was not performed if peak level lower than average limit. 2. Other frequency was 20dB below limit line within 1-18GHz, there is not show in the report.		

Mark	Frequency (MHz)	Reading Level (dB $\mu$ V)	Factor (dB)	Measure Level (dB $\mu$ V/m)	Limit (dB $\mu$ V/m)	Margin (dB)	Detector	Polarization
*	7113.1	44.5	7.6	52.1	88.2	-36.1	Peak	Horizontal
*	7864.3	44.4	8.4	52.8	88.2	-35.4	Peak	Horizontal
	9167.1	42.3	9.9	52.2	74.0	-21.8	Peak	Horizontal
	10613.3	40.8	12.4	53.2	74.0	-20.8	Peak	Horizontal
*	7110.1	44.8	7.5	52.3	88.2	-35.9	Peak	Vertical
*	7813.3	43.7	8.4	52.1	88.2	-36.1	Peak	Vertical
	9168.2	41.6	9.9	51.5	74.0	-22.5	Peak	Vertical
	10621.8	40.3	12.4	52.7	74.0	-21.3	Peak	Vertical

Note 1: "\*" is not in restricted band, its limit is -27dBm/MHz. At a distance of 3 meters, the field strength limit in dB $\mu$ V/m can be determined by adding a "conversion" factor of 95.2dB to the EIRP limit of -27dBm/MHz to obtain the limit for out of band spurious emissions.

Note 2: Measure Level (dB $\mu$ V/m) = Reading Level (dB $\mu$ V) + Factor (dB)

Factor (dB) = Cable Loss (dB) + Antenna Factor (dB/m) - Pre\_Amplifier Gain (dB)

Test Mode:	802.11a	Test Site:	AC1
Test Channel:	64	Test Engineer:	Roy Cheng
Remark:	1. Average measurement was not performed if peak level lower than average limit. 2. Other frequency was 20dB below limit line within 1-18GHz, there is not show in the report.		

Mark	Frequency (MHz)	Reading Level (dB $\mu$ V)	Factor (dB)	Measure Level (dB $\mu$ V/m)	Limit (dB $\mu$ V/m)	Margin (dB)	Detector	Polarization
*	7211.2	43.9	7.8	51.7	88.2	-36.5	Peak	Horizontal
*	7813.2	43.1	8.4	51.5	88.2	-36.7	Peak	Horizontal
	9113.1	41.9	9.5	51.4	74.0	-22.6	Peak	Horizontal
	10655.8	40.2	12.3	52.5	74.0	-21.5	Peak	Horizontal
*	7203.3	43.9	7.8	51.7	88.2	-36.5	Peak	Vertical
*	7901.1	43.0	8.3	51.3	88.2	-36.9	Peak	Vertical
	9364.2	42.7	10.5	53.2	74.0	-20.8	Peak	Vertical
	10689.8	39.4	12.4	51.8	74.0	-22.2	Peak	Vertical

Note 1: "\*" is not in restricted band, its limit is -27dBm/MHz. At a distance of 3 meters, the field strength limit in dB $\mu$ V/m can be determined by adding a "conversion" factor of 95.2dB to the EIRP limit of -27dBm/MHz to obtain the limit for out of band spurious emissions.

Note 2: Measure Level (dB $\mu$ V/m) = Reading Level (dB $\mu$ V) + Factor (dB)

Factor (dB) = Cable Loss (dB) + Antenna Factor (dB/m) - Pre\_Amplifier Gain (dB)



Test Mode:	802.11a	Test Site:	AC1
Test Channel:	100	Test Engineer:	Roy Cheng
Remark:	1. Average measurement was not performed if peak level lower than average limit. 2. Other frequency was 20dB below limit line within 1-18GHz, there is not show in the report.		

Mark	Frequency (MHz)	Reading Level (dB $\mu$ V)	Factor (dB)	Measure Level (dB $\mu$ V/m)	Limit (dB $\mu$ V/m)	Margin (dB)	Detector	Polarization
*	7204.2	43.7	7.8	51.5	88.2	-36.7	Peak	Horizontal
*	7806.1	42.8	8.4	51.2	88.2	-37.0	Peak	Horizontal
	9106.3	41.2	9.4	50.6	74.0	-23.4	Peak	Horizontal
	10621.7	41.4	12.4	53.8	74.0	-20.2	Peak	Horizontal
*	7211.3	44.0	7.8	51.8	88.2	-36.4	Peak	Vertical
*	7861.3	43.9	8.4	52.3	88.2	-35.9	Peak	Vertical
	9168.3	42.4	9.9	52.3	74.0	-21.7	Peak	Vertical
	10706.7	40.8	12.4	53.2	74.0	-20.8	Peak	Vertical

Note 1: "\*" is not in restricted band, its limit is -27dBm/MHz. At a distance of 3 meters, the field strength limit in dB $\mu$ V/m can be determined by adding a "conversion" factor of 95.2dB to the EIRP limit of -27dBm/MHz to obtain the limit for out of band spurious emissions.

Note 2: Measure Level (dB $\mu$ V/m) = Reading Level (dB $\mu$ V) + Factor (dB)

Factor (dB) = Cable Loss (dB) + Antenna Factor (dB/m) - Pre\_Amplifier Gain (dB)

Test Mode:	802.11a	Test Site:	AC1
Test Channel:	120	Test Engineer:	Roy Cheng
Remark:	1. Average measurement was not performed if peak level lower than average limit. 2. Other frequency was 20dB below limit line within 1-18GHz, there is not show in the report.		

Mark	Frequency (MHz)	Reading Level (dB $\mu$ V)	Factor (dB)	Measure Level (dB $\mu$ V/m)	Limit (dB $\mu$ V/m)	Margin (dB)	Detector	Polarization
*	7022.2	43.4	6.9	50.3	88.2	-37.9	Peak	Horizontal
*	7753.4	43.0	8.1	51.1	88.2	-37.1	Peak	Horizontal
	9153.4	41.4	9.8	51.2	74.0	-22.8	Peak	Horizontal
	10625.3	39.9	12.4	52.3	74.0	-21.7	Peak	Horizontal
*	7026.4	42.2	6.9	49.1	88.2	-39.1	Peak	Vertical
*	7759.4	42.3	8.1	50.4	88.2	-37.8	Peak	Vertical
	9173.2	42.3	9.9	52.2	74.0	-21.8	Peak	Vertical
	12503.3	39.8	11.4	51.2	74.0	-22.8	Peak	Vertical

Note 1: "\*" is not in restricted band, its limit is -27dBm/MHz. At a distance of 3 meters, the field strength limit in dB $\mu$ V/m can be determined by adding a "conversion" factor of 95.2dB to the EIRP limit of -27dBm/MHz to obtain the limit for out of band spurious emissions.

Note 2: Measure Level (dB $\mu$ V/m) = Reading Level (dB $\mu$ V) + Factor (dB)

Factor (dB) = Cable Loss (dB) + Antenna Factor (dB/m) - Pre\_Amplifier Gain (dB)

Test Mode:	802.11a	Test Site:	AC1
Test Channel:	140	Test Engineer:	Roy Cheng
Remark:	1. Average measurement was not performed if peak level lower than average limit. 2. Other frequency was 20dB below limit line within 1-18GHz, there is not show in the report.		

Mark	Frequency (MHz)	Reading Level (dB $\mu$ V)	Factor (dB)	Measure Level (dB $\mu$ V/m)	Limit (dB $\mu$ V/m)	Margin (dB)	Detector	Polarization
*	7149.4	41.7	7.7	49.4	88.2	-38.8	Peak	Horizontal
*	7762.2	40.9	8.2	49.1	88.2	-39.1	Peak	Horizontal
	9153.3	41.7	9.8	51.5	74.0	-22.5	Peak	Horizontal
	11811.8	40.3	11.9	52.2	74.0	-21.8	Peak	Horizontal
*	7149.6	42.4	7.7	50.1	88.2	-38.1	Peak	Vertical
*	7754.6	42.3	8.1	50.4	88.2	-37.8	Peak	Vertical
	9173.4	42.1	9.9	52.0	74.0	-22.0	Peak	Vertical
	12430.3	40.0	11.5	51.5	74.0	-22.5	Peak	Vertical

Note 1: "\*" is not in restricted band, its limit is -27dBm/MHz. At a distance of 3 meters, the field strength limit in dB $\mu$ V/m can be determined by adding a "conversion" factor of 95.2dB to the EIRP limit of -27dBm/MHz to obtain the limit for out of band spurious emissions.

Note 2: Measure Level (dB $\mu$ V/m) = Reading Level (dB $\mu$ V) + Factor (dB)

Factor (dB) = Cable Loss (dB) + Antenna Factor (dB/m) - Pre\_Amplifier Gain (dB)

Test Mode:	802.11a	Test Site:	AC1
Test Channel:	149	Test Engineer:	Roy Cheng
Remark:	1. Average measurement was not performed if peak level lower than average limit. 2. Other frequency was 20dB below limit line within 1-18GHz, there is not show in the report.		

Mark	Frequency (MHz)	Reading Level (dBμV)	Factor (dB)	Measure Level (dBμV/m)	Limit (dBμV/m)	Margin (dB)	Detector	Polarization
	7326.0	38.2	8.0	46.2	74.0	-27.8	Peak	Horizontal
*	9245.7	37.3	10.2	47.5	88.2	-40.7	Peak	Horizontal
	11487.8	33.3	12.8	46.1	54.0	-7.9	Average	Horizontal
	11488.8	43.8	12.8	56.6	74.0	-17.4	Peak	Horizontal
*	17234.8	47.5	15.9	63.4	88.2	-24.8	Peak	Horizontal
	7323.9	37.8	8.0	45.8	74.0	-28.2	Peak	Vertical
*	9243.3	36.6	10.2	46.8	88.2	-41.4	Peak	Vertical
	11488.7	40.9	12.8	53.7	74.0	-20.3	Peak	Vertical
*	17234.7	42.8	15.9	58.7	88.2	-29.5	Peak	Vertical

Note 1: "\*" is not in restricted band, its limit is -27dBm/MHz or -17dBm/MHz. At a distance of 3 meters, the field strength limit in dBμV/m can be determined by adding a "conversion" factor of 95.2dB to the EIRP limit of -27dBm/MHz to obtain the limit for out of band spurious emissions.

Note 2: Measure Level (dBμV/m) = Reading Level (dBμV) + Factor (dB)

Factor (dB) = Cable Loss (dB) + Antenna Factor (dB/m) - Pre\_Amplifier Gain (dB)

Test Mode:	802.11a	Test Site:	AC1
Test Channel:	157	Test Engineer:	Roy Cheng
Remark:	1. Average measurement was not performed if peak level lower than average limit. 2. Other frequency was 20dB below limit line within 1-18GHz, there is not show in the report.		

Mark	Frequency (MHz)	Reading Level (dB $\mu$ V)	Factor (dB)	Measure Level (dB $\mu$ V/m)	Limit (dB $\mu$ V/m)	Margin (dB)	Detector	Polarization
	7325.0	37.1	8.0	45.1	74.0	-28.9	Peak	Horizontal
*	9253.2	37.9	10.2	48.1	88.2	-40.1	Peak	Horizontal
	11565.2	39.3	12.7	52.0	74.0	-22.0	Peak	Horizontal
*	17353.8	47.6	16.9	64.5	88.2	-23.7	Peak	Horizontal
	7314.0	37.9	8.0	45.9	74.0	-28.1	Peak	Vertical
*	9275.7	37.5	10.3	47.8	88.2	-40.4	Peak	Vertical
	11565.3	38.4	12.7	51.1	74.0	-22.9	Peak	Vertical
*	17345.3	42.3	16.8	59.1	88.2	-29.1	Peak	Vertical

Note 1: "\*" is not in restricted band, its limit is -27dBm/MHz or -17dBm/MHz. At a distance of 3 meters, the field strength limit in dB $\mu$ V/m can be determined by adding a "conversion" factor of 95.2dB to the EIRP limit of -27dBm/MHz to obtain the limit for out of band spurious emissions.

Note 2: Measure Level (dB $\mu$ V/m) = Reading Level (dB $\mu$ V) + Factor (dB)

Factor (dB) = Cable Loss (dB) + Antenna Factor (dB/m) - Pre\_Amplifier Gain (dB)

Test Mode:	802.11a	Test Site:	AC1
Test Channel:	165	Test Engineer:	Roy Cheng
Remark:	1. Average measurement was not performed if peak level lower than average limit. 2. Other frequency was 20dB below limit line within 1-18GHz, there is not show in the report.		

Mark	Frequency (MHz)	Reading Level (dB $\mu$ V)	Factor (dB)	Measure Level (dB $\mu$ V/m)	Limit (dB $\mu$ V/m)	Margin (dB)	Detector	Polarization
	7341.6	37.0	8.0	45.0	74.0	-29.0	Peak	Horizontal
*	9286.1	36.6	10.3	46.9	88.2	-41.3	Peak	Horizontal
	11650.3	40.2	12.3	52.5	74.0	-21.5	Peak	Horizontal
*	17472.8	46.3	17.2	63.5	88.2	-24.7	Peak	Horizontal
	7359.5	39.2	8.0	47.2	74.0	-26.8	Peak	Vertical
*	9247.7	37.2	10.2	47.4	88.2	-40.8	Peak	Vertical
	11650.0	32.5	12.3	44.8	54.0	-9.2	Average	Vertical
	11650.1	42.8	12.3	55.1	74.0	-18.9	Peak	Vertical
*	17472.7	42.6	17.2	59.8	88.2	-28.4	Peak	Vertical

Note 1: "\*" is not in restricted band, its limit is -27dBm/MHz or -17dBm/MHz. At a distance of 3 meters, the field strength limit in dB $\mu$ V/m can be determined by adding a "conversion" factor of 95.2dB to the EIRP limit of -27dBm/MHz to obtain the limit for out of band spurious emissions.

Note 2: Measure Level (dB $\mu$ V/m) = Reading Level (dB $\mu$ V) + Factor (dB)

Factor (dB) = Cable Loss (dB) + Antenna Factor (dB/m) - Pre\_Amplifier Gain (dB)

\_\_\_\_\_ The End \_\_\_\_\_