

7. Trace was allowed to stabilize

Quasi-Peak Measurements below 1GHz

1. Analyzer center frequency was set to the frequency of the radiated spurious emission of interest
2. Span was set greater than 1MHz
3. RBW = 120 kHz
4. Detector = CISPR quasi-peak
5. Sweep time = auto couple
6. Trace was allowed to stabilize

Average Measurements above 1GHz (Method VB)

1. RBW = 1 MHz.
2. Video bandwidth.
 - If the EUT is configured to transmit with duty cycle ≥ 98 percent, set $VBW \leq RBW/100$ (i.e., 10 kHz) but not less than 10 Hz.
 - If the EUT duty cycle is < 98 percent, set $VBW \geq 1/T$
3. Video bandwidth mode
 - The instrument shall be set to ensure that video filtering is applied in the power domain. Typically, this requires setting the detector mode to RMS and setting the Average-VBW Type to Power (RMS).
4. Detector = Peak.
5. Sweep time = auto.
6. Trace mode = max hold.
7. Allow max hold to run for at least 50 traces if the transmitted signal is continuous or has at least 98 percent duty cycle. For lower duty cycles, increase the minimum number of traces by a factor of $1/x$, where x is the duty cycle. For example, use at least 200 traces if the duty cycle is 25 percent. (If a specific emission is demonstrated to be continuous—i.e., 100 percent duty cycle—rather than turning on and off with the transmit cycle, at least 50 traces shall be averaged.)

7.8.4. Test Setup

9kHz ~ 30MHz Test Setup:

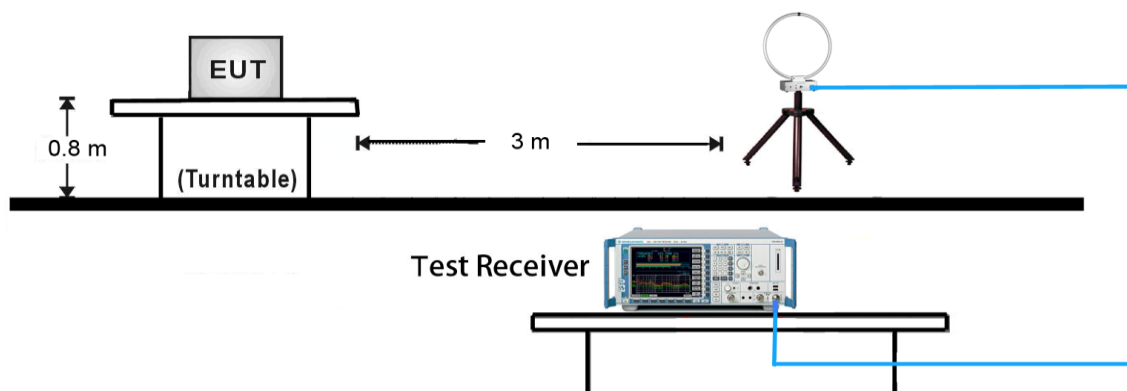

30MHz ~ 1GHz Test Setup:

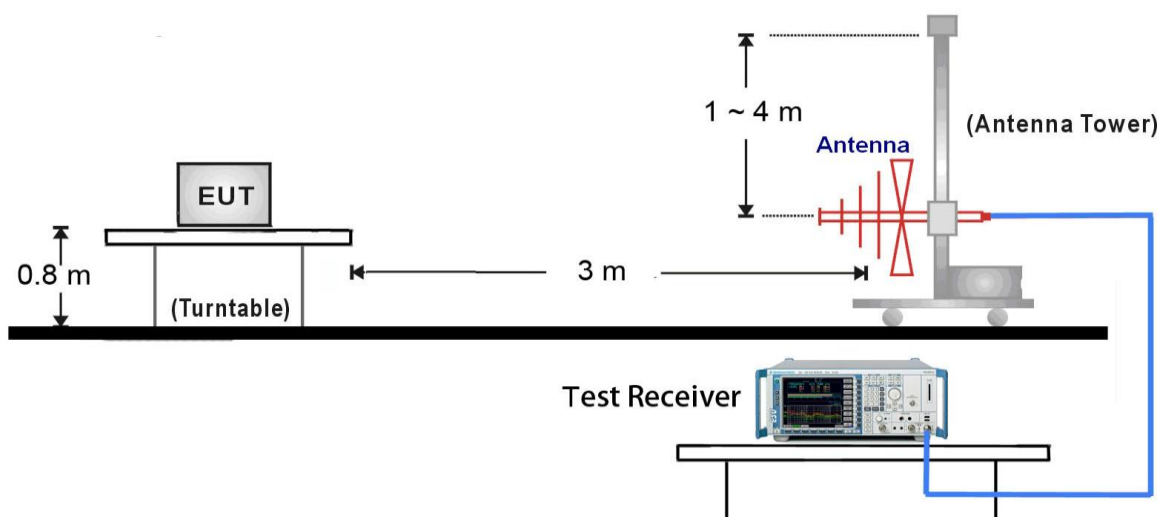

1GHz ~ 18GHz Test Setup:

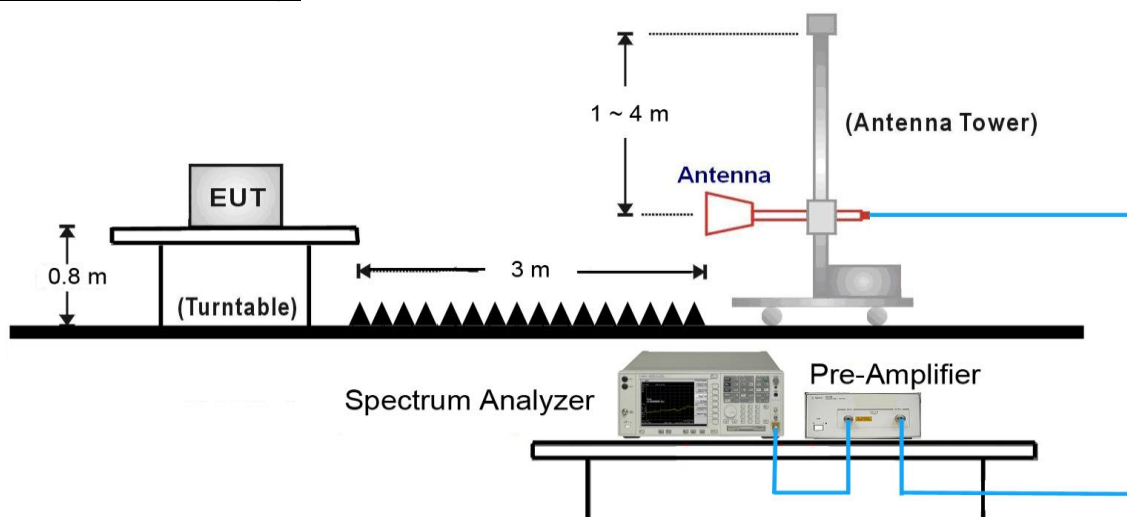

18GHz ~40GHz Test Setup:

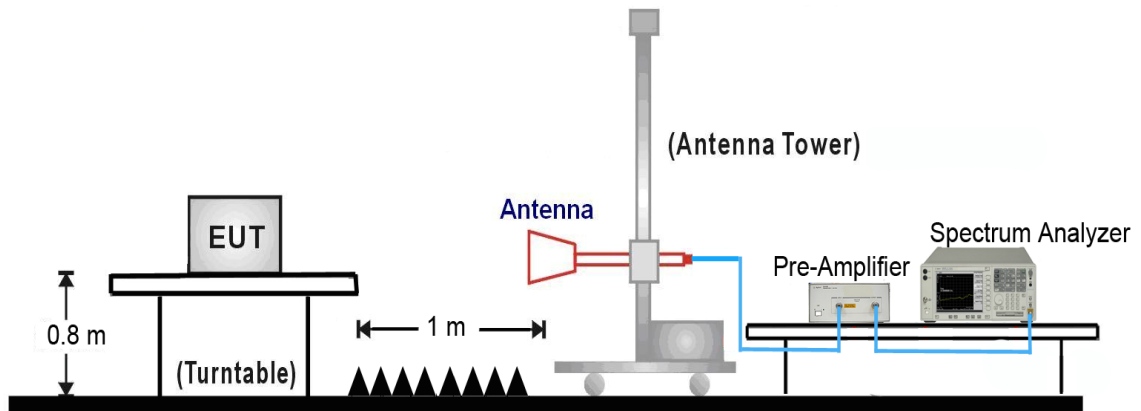

7.8.5. Test Result

Test Mode:	802.11a	Test Site:	AC1
Test Channel:	36	Test Engineer:	Roy Cheng
Remark:	1. Average measurement was not performed if peak level lower than average limit. 2. Other frequency was 20dB below limit line within 1-18GHz, there is not show in the report.		

Mark	Frequency (MHz)	Reading Level (dB μ V)	Factor (dB)	Measure Level (dB μ V/m)	Limit (dB μ V/m)	Margin (dB)	Detector	Polarization
*	7008.0	37.7	12.8	50.5	68.2	-17.7	Peak	Horizontal
*	7869.0	35.9	15.0	50.9	68.2	-17.3	Peak	Horizontal
	9137.0	35.9	15.1	51.0	74.0	-23.0	Peak	Horizontal
	10698.5	33.4	17.7	51.1	74.0	-22.9	Peak	Horizontal
*	7132.5	37.0	13.5	50.5	68.2	-17.7	Peak	Vertical
*	7963.5	36.2	15.0	51.2	68.2	-17.0	Peak	Vertical
	9467.5	37.7	15.4	53.1	74.0	-20.9	Peak	Vertical
	10673.0	33.8	17.7	51.5	74.0	-22.5	Peak	Vertical

Note 1: "*" is not in restricted band, its limit is -27dBm/MHz. At a distance of 3 meters, the field strength limit in dB μ V/m can be determined by adding a "conversion" factor of 95.2dB to the EIRP limit of -27dBm/MHz to obtain the limit for out of band spurious emissions of 68.2dB μ V/m.

Note 2: Measure Level (dB μ V/m) = Reading Level (dB μ V) + Factor (dB)

Factor (dB) = Cable Loss (dB) + Antenna Factor (dB/m) - Pre_Amplifier Gain (dB)

Test Mode:	802.11a	Test Site:	AC1
Test Channel:	44	Test Engineer:	Roy Cheng
Remark:	1. Average measurement was not performed if peak level lower than average limit. 2. Other frequency was 20dB below limit line within 1-18GHz, there is not show in the report.		

Mark	Frequency (MHz)	Reading Level (dB μ V)	Factor (dB)	Measure Level (dB μ V/m)	Limit (dB μ V/m)	Margin (dB)	Detector	Polarization
*	6192.0	37.5	9.1	46.6	68.2	-21.6	Peak	Horizontal
*	7911.5	36.1	15.0	51.1	68.2	-17.1	Peak	Horizontal
	9137.5	34.5	15.1	49.6	74.0	-24.4	Peak	Horizontal
	10656.0	33.3	17.9	51.2	74.0	-22.8	Peak	Horizontal
*	7111.5	37.7	13.4	51.1	68.2	-17.1	Peak	Vertical
*	7794.5	35.4	15.0	50.4	68.2	-17.8	Peak	Vertical
	9364.5	37.1	15.3	52.4	74.0	-21.6	Peak	Vertical
	10639.0	34.2	18.0	52.2	74.0	-21.8	Peak	Vertical

Note 1: "*" is not in restricted band, its limit is -27dBm/MHz. At a distance of 3 meters, the field strength limit in dB μ V/m can be determined by adding a "conversion" factor of 95.2dB to the EIRP limit of -27dBm/MHz to obtain the limit for out of band spurious emissions of 68.2dB μ V/m.

Note 2: Measure Level (dB μ V/m) = Reading Level (dB μ V) + Factor (dB)

Factor (dB) = Cable Loss (dB) + Antenna Factor (dB/m) - Pre_Amplifier Gain (dB)

Test Mode:	802.11a	Test Site:	AC1
Test Channel:	48	Test Engineer:	Roy Cheng
Remark:	1. Average measurement was not performed if peak level lower than average limit. 2. Other frequency was 20dB below limit line within 1-18GHz, there is not show in the report.		

Mark	Frequency (MHz)	Reading Level (dB μ V)	Factor (dB)	Measure Level (dB μ V/m)	Limit (dB μ V/m)	Margin (dB)	Detector	Polarization
*	7111.5	37.6	13.4	51.0	68.2	-17.2	Peak	Horizontal
*	7816.5	34.8	15.0	49.8	68.2	-18.4	Peak	Horizontal
	9169.5	34.9	15.3	50.2	74.0	-23.8	Peak	Horizontal
	10690.0	33.6	17.6	51.2	74.0	-22.8	Peak	Horizontal
*	7231.0	36.1	13.8	49.9	68.2	-18.3	Peak	Vertical
*	7769.5	35.1	14.9	50.0	68.2	-18.2	Peak	Vertical
	9466.5	37.8	15.4	53.2	74.0	-20.8	Peak	Vertical
	10681.5	33.4	17.6	51.0	74.0	-23.0	Peak	Vertical

Note 1: "*" is not in restricted band, its limit is -27dBm/MHz. At a distance of 3 meters, the field strength limit in dB μ V/m can be determined by adding a "conversion" factor of 95.2dB to the EIRP limit of -27dBm/MHz to obtain the limit for out of band spurious emissions of 68.2dB μ V/m.

Note 2: Measure Level (dB μ V/m) = Reading Level (dB μ V) + Factor (dB)

Factor (dB) = Cable Loss (dB) + Antenna Factor (dB/m) - Pre_Amplifier Gain (dB)

Test Mode:	802.11a	Test Site:	AC1
Test Channel:	52	Test Engineer:	Roy Cheng
Remark:	1. Average measurement was not performed if peak level lower than average limit. 2. Other frequency was 20dB below limit line within 1-18GHz, there is not show in the report.		

Mark	Frequency (MHz)	Reading Level (dB μ V)	Factor (dB)	Measure Level (dB μ V/m)	Limit (dB μ V/m)	Margin (dB)	Detector	Polarization
*	7046.5	36.5	13.1	49.6	68.2	-18.6	Peak	Horizontal
*	7832.5	36.5	15.1	51.6	68.2	-16.6	Peak	Horizontal
	9066.5	34.5	14.5	49.0	74.0	-25.0	Peak	Horizontal
	10809.0	34.2	18.2	52.4	74.0	-21.6	Peak	Horizontal
*	7016.5	37.5	12.9	50.4	68.2	-17.8	Peak	Vertical
*	7963.5	36.6	15.0	51.6	68.2	-16.6	Peak	Vertical
	9167.5	34.9	15.3	50.2	74.0	-23.8	Peak	Vertical
	10698.5	33.3	17.7	51.0	74.0	-23.0	Peak	Vertical

Note 1: "*" is not in restricted band, its limit is -27dBm/MHz. At a distance of 3 meters, the field strength limit in dB μ V/m can be determined by adding a "conversion" factor of 95.2dB to the EIRP limit of -27dBm/MHz to obtain the limit for out of band spurious emissions of 68.2dB μ V/m.

Note 2: Measure Level (dB μ V/m) = Reading Level (dB μ V) + Factor (dB)

Factor (dB) = Cable Loss (dB) + Antenna Factor (dB/m) - Pre_Amplifier Gain (dB)

Test Mode:	802.11a	Test Site:	AC1
Test Channel:	60	Test Engineer:	Roy Cheng
Remark:	1. Average measurement was not performed if peak level lower than average limit. 2. Other frequency was 20dB below limit line within 1-18GHz, there is not show in the report.		

Mark	Frequency (MHz)	Reading Level (dB μ V)	Factor (dB)	Measure Level (dB μ V/m)	Limit (dB μ V/m)	Margin (dB)	Detector	Polarization
*	7113.5	37.0	13.4	50.4	68.2	-17.8	Peak	Horizontal
*	7864.5	35.6	15.0	50.6	68.2	-17.6	Peak	Horizontal
	9167.4	34.9	15.3	50.2	74.0	-23.8	Peak	Horizontal
	10613.5	34.1	17.8	51.9	74.0	-22.1	Peak	Horizontal
*	7110.5	36.7	13.4	50.1	68.2	-18.1	Peak	Vertical
*	7813.5	35.2	15.0	50.2	68.2	-18.0	Peak	Vertical
	9168.5	35.0	15.3	50.3	74.0	-23.7	Peak	Vertical
	10622.0	33.7	17.9	51.6	74.0	-22.4	Peak	Vertical

Note 1: "*" is not in restricted band, its limit is -27dBm/MHz. At a distance of 3 meters, the field strength limit in dB μ V/m can be determined by adding a "conversion" factor of 95.2dB to the EIRP limit of -27dBm/MHz to obtain the limit for out of band spurious emissions of 68.2dB μ V/m.

Note 2: Measure Level (dB μ V/m) = Reading Level (dB μ V) + Factor (dB)

Factor (dB) = Cable Loss (dB) + Antenna Factor (dB/m) - Pre_Amplifier Gain (dB)

Test Mode:	802.11a	Test Site:	AC1
Test Channel:	64	Test Engineer:	Roy Cheng
Remark:	1. Average measurement was not performed if peak level lower than average limit. 2. Other frequency was 20dB below limit line within 1-18GHz, there is not show in the report.		

Mark	Frequency (MHz)	Reading Level (dB μ V)	Factor (dB)	Measure Level (dB μ V/m)	Limit (dB μ V/m)	Margin (dB)	Detector	Polarization
*	7211.5	36.2	13.7	49.9	68.2	-18.3	Peak	Horizontal
*	7813.5	35.3	15.0	50.3	68.2	-17.9	Peak	Horizontal
	9113.5	34.4	14.7	49.1	74.0	-24.9	Peak	Horizontal
	10656.0	33.5	17.9	51.4	74.0	-22.6	Peak	Horizontal
*	7203.5	35.8	13.6	49.4	68.2	-18.8	Peak	Vertical
*	7901.5	35.1	15.0	50.1	68.2	-18.1	Peak	Vertical
	9364.4	36.4	15.3	51.7	74.0	-22.3	Peak	Vertical
	10690.0	33.2	17.6	50.8	74.0	-23.2	Peak	Vertical

Note 1: "*" is not in restricted band, its limit is -27dBm/MHz. At a distance of 3 meters, the field strength limit in dB μ V/m can be determined by adding a "conversion" factor of 95.2dB to the EIRP limit of -27dBm/MHz to obtain the limit for out of band spurious emissions of 68.2dB μ V/m.

Note 2: Measure Level (dB μ V/m) = Reading Level (dB μ V) + Factor (dB)

Factor (dB) = Cable Loss (dB) + Antenna Factor (dB/m) - Pre_Amplifier Gain (dB)

Test Mode:	802.11a	Test Site:	AC1
Test Channel:	100	Test Engineer:	Roy Cheng
Remark:	1. Average measurement was not performed if peak level lower than average limit. 2. Other frequency was 20dB below limit line within 1-18GHz, there is not show in the report.		

Mark	Frequency (MHz)	Reading Level (dB μ V)	Factor (dB)	Measure Level (dB μ V/m)	Limit (dB μ V/m)	Margin (dB)	Detector	Polarization
*	7204.5	35.9	13.6	49.5	68.2	-18.7	Peak	Horizontal
*	7806.5	35.1	15.0	50.1	68.2	-18.1	Peak	Horizontal
	9106.5	34.2	14.7	48.9	74.0	-25.1	Peak	Horizontal
	10622.0	33.7	17.9	51.6	74.0	-22.4	Peak	Horizontal
*	7211.5	36.2	13.7	49.9	68.2	-18.3	Peak	Vertical
*	7861.5	35.2	15.1	50.3	68.2	-17.9	Peak	Vertical
	9168.5	35.5	15.3	50.8	74.0	-23.2	Peak	Vertical
	10707.0	33.8	17.7	51.5	74.0	-22.5	Peak	Vertical

Note 1: "*" is not in restricted band, its limit is -27dBm/MHz. At a distance of 3 meters, the field strength limit in dB μ V/m can be determined by adding a "conversion" factor of 95.2dB to the EIRP limit of -27dBm/MHz to obtain the limit for out of band spurious emissions of 68.2dB μ V/m.

Note 2: Measure Level (dB μ V/m) = Reading Level (dB μ V) + Factor (dB)

Factor (dB) = Cable Loss (dB) + Antenna Factor (dB/m) - Pre_Amplifier Gain (dB)

Test Mode:	802.11a	Test Site:	AC1
Test Channel:	116	Test Engineer:	Roy Cheng
Remark:	1. Average measurement was not performed if peak level lower than average limit. 2. Other frequency was 20dB below limit line within 1-18GHz, there is not show in the report.		

Mark	Frequency (MHz)	Reading Level (dB μ V)	Factor (dB)	Measure Level (dB μ V/m)	Limit (dB μ V/m)	Margin (dB)	Detector	Polarization
*	7022.5	35.4	12.9	48.3	68.2	-19.9	Peak	Horizontal
*	7753.7	34.1	14.8	48.9	68.2	-19.3	Peak	Horizontal
	9153.6	34.8	15.3	50.1	74.0	-23.9	Peak	Horizontal
	10625.5	35.9	17.9	53.8	74.0	-20.2	Peak	Horizontal
*	7026.7	35.0	12.9	47.9	68.2	-20.3	Peak	Vertical
*	7759.6	33.2	14.8	48.0	68.2	-20.2	Peak	Vertical
	9173.5	35.4	15.3	50.7	74.0	-23.3	Peak	Vertical
	12503.5	33.9	19.7	53.6	74.0	-20.4	Peak	Vertical

Note 1: "*" is not in restricted band, its limit is -27dBm/MHz. At a distance of 3 meters, the field strength limit in dB μ V/m can be determined by adding a "conversion" factor of 95.2dB to the EIRP limit of -27dBm/MHz to obtain the limit for out of band spurious emissions of 68.2dB μ V/m.

Note 2: Measure Level (dB μ V/m) = Reading Level (dB μ V) + Factor (dB)

Factor (dB) = Cable Loss (dB) + Antenna Factor (dB/m) - Pre_Amplifier Gain (dB)

Test Mode:	802.11a	Test Site:	AC1
Test Channel:	140	Test Engineer:	Roy Cheng
Remark:	1. Average measurement was not performed if peak level lower than average limit. 2. Other frequency was 20dB below limit line within 1-18GHz, there is not show in the report.		

Mark	Frequency (MHz)	Reading Level (dB μ V)	Factor (dB)	Measure Level (dB μ V/m)	Limit (dB μ V/m)	Margin (dB)	Detector	Polarization
*	7149.7	34.1	13.5	47.6	68.2	-20.6	Peak	Horizontal
*	7762.4	33.2	14.8	48.0	68.2	-20.2	Peak	Horizontal
	9153.6	34.7	15.3	50.0	74.0	-24.0	Peak	Horizontal
	11812.0	33.2	19.3	52.5	74.0	-21.5	Peak	Horizontal
*	7149.8	34.3	13.5	47.8	68.2	-20.4	Peak	Vertical
*	7754.8	33.5	14.8	48.3	68.2	-19.9	Peak	Vertical
	9173.6	35.0	15.3	50.3	74.0	-23.7	Peak	Vertical
	12430.5	34.2	19.4	53.6	74.0	-20.4	Peak	Vertical

Note 1: "*" is not in restricted band, its limit is -27dBm/MHz. At a distance of 3 meters, the field strength limit in dB μ V/m can be determined by adding a "conversion" factor of 95.2dB to the EIRP limit of -27dBm/MHz to obtain the limit for out of band spurious emissions of 68.2dB μ V/m.

Note 2: Measure Level (dB μ V/m) = Reading Level (dB μ V) + Factor (dB)

Factor (dB) = Cable Loss (dB) + Antenna Factor (dB/m) - Pre_Amplifier Gain (dB)

Test Mode:	802.11n-HT20	Test Site:	AC1
Test Channel:	36	Test Engineer:	Roy Cheng
Remark:	1. Average measurement was not performed if peak level lower than average limit. 2. Other frequency was 20dB below limit line within 1-18GHz, there is not show in the report.		

Mark	Frequency (MHz)	Reading Level (dB μ V)	Factor (dB)	Measure Level (dB μ V/m)	Limit (dB μ V/m)	Margin (dB)	Detector	Polarization
*	7215.7	34.2	13.7	47.9	68.2	-20.3	Peak	Horizontal
*	8513.5	34.2	14.6	48.8	68.2	-19.4	Peak	Horizontal
	9362.5	35.2	15.3	50.5	74.0	-23.5	Peak	Horizontal
	12536.4	33.8	19.9	53.7	74.0	-20.3	Peak	Horizontal
*	7025.6	36.0	12.9	48.9	68.2	-19.3	Peak	Vertical
*	7753.7	34.1	14.8	48.9	68.2	-19.3	Peak	Vertical
	9342.7	35.2	15.4	50.6	74.0	-23.4	Peak	Vertical
	12571.1	33.8	20.0	53.8	74.0	-20.2	Peak	Vertical

Note 1: "*" is not in restricted band, its limit is -27dBm/MHz. At a distance of 3 meters, the field strength limit in dB μ V/m can be determined by adding a "conversion" factor of 95.2dB to the EIRP limit of -27dBm/MHz to obtain the limit for out of band spurious emissions of 68.2dB μ V/m.

Note 2: Measure Level (dB μ V/m) = Reading Level (dB μ V) + Factor (dB)

Factor (dB) = Cable Loss (dB) + Antenna Factor (dB/m) - Pre_Amplifier Gain (dB)

Test Mode:	802.11n-HT20	Test Site:	AC1
Test Channel:	44	Test Engineer:	Roy Cheng
Remark:	1. Average measurement was not performed if peak level lower than average limit. 2. Other frequency was 20dB below limit line within 1-18GHz, there is not show in the report.		

Mark	Frequency (MHz)	Reading Level (dB μ V)	Factor (dB)	Measure Level (dB μ V/m)	Limit (dB μ V/m)	Margin (dB)	Detector	Polarization
*	7145.8	34.2	13.5	47.7	68.2	-20.5	Peak	Horizontal
*	8543.6	34.0	14.5	48.5	68.2	-19.7	Peak	Horizontal
	9471.8	35.2	15.4	50.6	74.0	-23.4	Peak	Horizontal
	12431.6	34.2	19.4	53.6	74.0	-20.4	Peak	Horizontal
*	7184.3	33.8	13.6	47.4	68.2	-20.8	Peak	Vertical
*	7762.4	33.4	14.8	48.2	68.2	-20.0	Peak	Vertical
	9326.5	35.1	15.4	50.5	74.0	-23.5	Peak	Vertical
	12662.0	33.3	19.9	53.2	74.0	-20.8	Peak	Vertical

Note 1: "*" is not in restricted band, its limit is -27dBm/MHz. At a distance of 3 meters, the field strength limit in dB μ V/m can be determined by adding a "conversion" factor of 95.2dB to the EIRP limit of -27dBm/MHz to obtain the limit for out of band spurious emissions of 68.2dB μ V/m.

Note 2: Measure Level (dB μ V/m) = Reading Level (dB μ V) + Factor (dB)

Factor (dB) = Cable Loss (dB) + Antenna Factor (dB/m) - Pre_Amplifier Gain (dB)

Test Mode:	802.11n-HT20	Test Site:	AC1
Test Channel:	48	Test Engineer:	Roy Cheng
Remark:	1. Average measurement was not performed if peak level lower than average limit. 2. Other frequency was 20dB below limit line within 1-18GHz, there is not show in the report.		

Mark	Frequency (MHz)	Reading Level (dB μ V)	Factor (dB)	Measure Level (dB μ V/m)	Limit (dB μ V/m)	Margin (dB)	Detector	Polarization
*	7045.5	36.2	13.1	49.3	68.2	-18.9	Peak	Horizontal
*	7625.5	35.1	14.6	49.7	68.2	-18.5	Peak	Horizontal
	9152.7	36.0	15.3	51.3	74.0	-22.7	Peak	Horizontal
	11803.5	33.7	19.3	53.0	74.0	-21.0	Peak	Horizontal
*	7152.6	34.1	13.6	47.7	68.2	-20.5	Peak	Vertical
*	7915.2	34.2	15.0	49.2	68.2	-19.0	Peak	Vertical
	9173.5	34.6	15.3	49.9	74.0	-24.1	Peak	Vertical
	11319.0	32.9	19.1	52.0	74.0	-22.0	Peak	Vertical

Note 1: "*" is not in restricted band, its limit is -27dBm/MHz. At a distance of 3 meters, the field strength limit in dB μ V/m can be determined by adding a "conversion" factor of 95.2dB to the EIRP limit of -27dBm/MHz to obtain the limit for out of band spurious emissions of 68.2dB μ V/m.

Note 2: Measure Level (dB μ V/m) = Reading Level (dB μ V) + Factor (dB)

Factor (dB) = Cable Loss (dB) + Antenna Factor (dB/m) - Pre_Amplifier Gain (dB)

Test Mode:	802.11n-HT20	Test Site:	AC1
Test Channel:	52	Test Engineer:	Roy Cheng
Remark:	1. Average measurement was not performed if peak level lower than average limit. 2. Other frequency was 20dB below limit line within 1-18GHz, there is not show in the report.		

Mark	Frequency (MHz)	Reading Level (dB μ V)	Factor (dB)	Measure Level (dB μ V/m)	Limit (dB μ V/m)	Margin (dB)	Detector	Polarization
*	7146.7	34.7	13.5	48.2	68.2	-20.0	Peak	Horizontal
*	8512.5	34.9	14.6	49.5	68.2	-18.7	Peak	Horizontal
	9173.7	34.9	15.3	50.2	74.0	-23.8	Peak	Horizontal
	11276.5	34.1	18.8	52.9	74.0	-21.1	Peak	Horizontal
*	7025.6	36.0	12.9	48.9	68.2	-19.3	Peak	Vertical
*	7753.7	33.5	14.8	48.3	68.2	-19.9	Peak	Vertical
	9183.8	34.9	15.3	50.2	74.0	-23.8	Peak	Vertical
	11276.5	33.7	18.8	52.5	74.0	-21.5	Peak	Vertical

Note 1: "*" is not in restricted band, its limit is -27dBm/MHz. At a distance of 3 meters, the field strength limit in dB μ V/m can be determined by adding a "conversion" factor of 95.2dB to the EIRP limit of -27dBm/MHz to obtain the limit for out of band spurious emissions of 68.2dB μ V/m.

Note 2: Measure Level (dB μ V/m) = Reading Level (dB μ V) + Factor (dB)

Factor (dB) = Cable Loss (dB) + Antenna Factor (dB/m) - Pre_Amplifier Gain (dB)

Test Mode:	802.11n-HT20	Test Site:	AC1
Test Channel:	60	Test Engineer:	Roy Cheng
Remark:	1. Average measurement was not performed if peak level lower than average limit. 2. Other frequency was 20dB below limit line within 1-18GHz, there is not show in the report.		

Mark	Frequency (MHz)	Reading Level (dB μ V)	Factor (dB)	Measure Level (dB μ V/m)	Limit (dB μ V/m)	Margin (dB)	Detector	Polarization
*	7024.7	35.2	12.9	48.1	68.2	-20.1	Peak	Horizontal
*	8512.7	35.2	14.6	49.8	68.2	-18.4	Peak	Horizontal
	9153.7	35.9	15.3	51.2	74.0	-22.8	Peak	Horizontal
	11820.5	33.3	19.3	52.6	74.0	-21.4	Peak	Horizontal
*	7025.7	35.4	12.9	48.3	68.2	-19.9	Peak	Vertical
*	7759.7	33.8	14.8	48.6	68.2	-19.6	Peak	Vertical
	9153.7	35.7	15.3	51.0	74.0	-23.0	Peak	Vertical
	12067.0	33.6	19.2	52.8	74.0	-21.2	Peak	Vertical

Note 1: "*" is not in restricted band, its limit is -27dBm/MHz. At a distance of 3 meters, the field strength limit in dB μ V/m can be determined by adding a "conversion" factor of 95.2dB to the EIRP limit of -27dBm/MHz to obtain the limit for out of band spurious emissions of 68.2dB μ V/m.

Note 2: Measure Level (dB μ V/m) = Reading Level (dB μ V) + Factor (dB)

Factor (dB) = Cable Loss (dB) + Antenna Factor (dB/m) - Pre_Amplifier Gain (dB)

Test Mode:	802.11n-HT20	Test Site:	AC1
Test Channel:	64	Test Engineer:	Roy Cheng
Remark:	1. Average measurement was not performed if peak level lower than average limit. 2. Other frequency was 20dB below limit line within 1-18GHz, there is not show in the report.		

Mark	Frequency (MHz)	Reading Level (dB μ V)	Factor (dB)	Measure Level (dB μ V/m)	Limit (dB μ V/m)	Margin (dB)	Detector	Polarization
*	7015.5	35.5	12.8	48.3	68.2	-19.9	Peak	Horizontal
*	8513.5	34.8	14.6	49.4	68.2	-18.8	Peak	Horizontal
	9125.5	34.7	14.9	49.6	74.0	-24.4	Peak	Horizontal
	11803.5	33.4	19.3	52.7	74.0	-21.3	Peak	Horizontal
*	7023.6	35.6	12.9	48.5	68.2	-19.7	Peak	Vertical
*	8513.7	35.8	14.6	50.4	68.2	-17.8	Peak	Vertical
	9173.5	34.9	15.3	50.2	74.0	-23.8	Peak	Vertical
	11803.5	32.6	19.3	51.9	74.0	-22.1	Peak	Vertical

Note 1: "*" is not in restricted band, its limit is -27dBm/MHz. At a distance of 3 meters, the field strength limit in dB μ V/m can be determined by adding a "conversion" factor of 95.2dB to the EIRP limit of -27dBm/MHz to obtain the limit for out of band spurious emissions of 68.2dB μ V/m.

Note 2: Measure Level (dB μ V/m) = Reading Level (dB μ V) + Factor (dB)

Factor (dB) = Cable Loss (dB) + Antenna Factor (dB/m) - Pre_Amplifier Gain (dB)

Test Mode:	802.11n-HT20	Test Site:	AC1
Test Channel:	100	Test Engineer:	Roy Cheng
Remark:	1. Average measurement was not performed if peak level lower than average limit. 2. Other frequency was 20dB below limit line within 1-18GHz, there is not show in the report.		

Mark	Frequency (MHz)	Reading Level (dB μ V)	Factor (dB)	Measure Level (dB μ V/m)	Limit (dB μ V/m)	Margin (dB)	Detector	Polarization
*	7140.6	34.4	13.5	47.9	68.2	-20.3	Peak	Horizontal
*	8514.7	34.2	14.6	48.8	68.2	-19.4	Peak	Horizontal
	9143.8	34.9	15.2	50.1	74.0	-23.9	Peak	Horizontal
	11854.5	33.0	19.5	52.5	74.0	-21.5	Peak	Horizontal
*	7145.5	33.7	13.5	47.2	68.2	-21.0	Peak	Vertical
*	8672.8	34.4	14.8	49.2	68.2	-19.0	Peak	Vertical
	9341.6	35.5	15.4	50.9	74.0	-23.1	Peak	Vertical
	11803.5	33.0	19.3	52.3	74.0	-21.7	Peak	Vertical

Note 1: "*" is not in restricted band, its limit is -27dBm/MHz. At a distance of 3 meters, the field strength limit in dB μ V/m can be determined by adding a "conversion" factor of 95.2dB to the EIRP limit of -27dBm/MHz to obtain the limit for out of band spurious emissions of 68.2dB μ V/m.

Note 2: Measure Level (dB μ V/m) = Reading Level (dB μ V) + Factor (dB)

Factor (dB) = Cable Loss (dB) + Antenna Factor (dB/m) - Pre_Amplifier Gain (dB)

Test Mode:	802.11n-HT20	Test Site:	AC1
Test Channel:	116	Test Engineer:	Roy Cheng
Remark:	1. Average measurement was not performed if peak level lower than average limit. 2. Other frequency was 20dB below limit line within 1-18GHz, there is not show in the report.		

Mark	Frequency (MHz)	Reading Level (dB μ V)	Factor (dB)	Measure Level (dB μ V/m)	Limit (dB μ V/m)	Margin (dB)	Detector	Polarization
*	7173.4	34.0	13.6	47.6	68.2	-20.6	Peak	Horizontal
*	8749.6	34.9	14.6	49.5	68.2	-18.7	Peak	Horizontal
	9348.7	35.2	15.4	50.6	74.0	-23.4	Peak	Horizontal
	12424.0	34.2	19.2	53.4	74.0	-20.6	Peak	Horizontal
*	7025.6	35.9	12.9	48.8	68.2	-19.4	Peak	Vertical
*	8671.6	34.4	14.8	49.2	68.2	-19.0	Peak	Vertical
	9472.7	35.9	15.4	51.3	74.0	-22.7	Peak	Vertical
	11803.5	32.8	19.3	52.1	74.0	-21.9	Peak	Vertical

Note 1: "*" is not in restricted band, its limit is -27dBm/MHz. At a distance of 3 meters, the field strength limit in dB μ V/m can be determined by adding a "conversion" factor of 95.2dB to the EIRP limit of -27dBm/MHz to obtain the limit for out of band spurious emissions of 68.2dB μ V/m.

Note 2: Measure Level (dB μ V/m) = Reading Level (dB μ V) + Factor (dB)

Factor (dB) = Cable Loss (dB) + Antenna Factor (dB/m) - Pre_Amplifier Gain (dB)

Test Mode:	802.11n-HT20	Test Site:	AC1
Test Channel:	140	Test Engineer:	Roy Cheng
Remark:	1. Average measurement was not performed if peak level lower than average limit. 2. Other frequency was 20dB below limit line within 1-18GHz, there is not show in the report.		

Mark	Frequency (MHz)	Reading Level (dB μ V)	Factor (dB)	Measure Level (dB μ V/m)	Limit (dB μ V/m)	Margin (dB)	Detector	Polarization
*	7218.5	34.0	13.7	47.7	68.2	-20.5	Peak	Horizontal
*	8647.6	34.6	14.8	49.4	68.2	-18.8	Peak	Horizontal
	9471.1	35.3	15.4	50.7	74.0	-23.3	Peak	Horizontal
	12568.5	33.3	20.0	53.3	74.0	-20.7	Peak	Horizontal
*	7149.9	34.5	13.5	48.0	68.2	-20.2	Peak	Vertical
*	8571.6	34.2	14.5	48.7	68.2	-19.5	Peak	Vertical
	9471.5	35.7	15.4	51.1	74.0	-22.9	Peak	Vertical
	11803.5	32.7	19.3	52.0	74.0	-22.0	Peak	Vertical

Note 1: "*" is not in restricted band, its limit is -27dBm/MHz. At a distance of 3 meters, the field strength limit in dB μ V/m can be determined by adding a "conversion" factor of 95.2dB to the EIRP limit of -27dBm/MHz to obtain the limit for out of band spurious emissions of 68.2dB μ V/m.

Note 2: Measure Level (dB μ V/m) = Reading Level (dB μ V) + Factor (dB)

Factor (dB) = Cable Loss (dB) + Antenna Factor (dB/m) - Pre_Amplifier Gain (dB)

Test Mode:	802.11ac-VHT20	Test Site:	AC1
Test Channel:	36	Test Engineer:	Roy Cheng
Remark:	1. Average measurement was not performed if peak level lower than average limit. 2. Other frequency was 20dB below limit line within 1-18GHz, there is not show in the report.		

Mark	Frequency (MHz)	Reading Level (dB μ V)	Factor (dB)	Measure Level (dB μ V/m)	Limit (dB μ V/m)	Margin (dB)	Detector	Polarization
*	7045.6	35.4	13.1	48.5	68.2	-19.7	Peak	Horizontal
*	7752.1	33.5	14.8	48.3	68.2	-19.9	Peak	Horizontal
	9179.5	35.4	15.3	50.7	74.0	-23.3	Peak	Horizontal
	12526.0	33.7	19.8	53.5	74.0	-20.5	Peak	Horizontal
*	7025.7	36.4	12.9	49.3	68.2	-18.9	Peak	Vertical
*	7691.5	34.9	14.5	49.4	68.2	-18.8	Peak	Vertical
	9482.5	35.2	15.4	50.6	74.0	-23.4	Peak	Vertical
	12424.0	33.2	19.2	52.4	74.0	-21.6	Peak	Vertical

Note 1: "*" is not in restricted band, its limit is -27dBm/MHz. At a distance of 3 meters, the field strength limit in dB μ V/m can be determined by adding a "conversion" factor of 95.2dB to the EIRP limit of -27dBm/MHz to obtain the limit for out of band spurious emissions of 68.2dB μ V/m.

Note 2: Measure Level (dB μ V/m) = Reading Level (dB μ V) + Factor (dB)

Factor (dB) = Cable Loss (dB) + Antenna Factor (dB/m) - Pre_Amplifier Gain (dB)

Test Mode:	802.11ac-VHT20	Test Site:	AC1
Test Channel:	44	Test Engineer:	Roy Cheng
Remark:	1. Average measurement was not performed if peak level lower than average limit. 2. Other frequency was 20dB below limit line within 1-18GHz, there is not show in the report.		

Mark	Frequency (MHz)	Reading Level (dB μ V)	Factor (dB)	Measure Level (dB μ V/m)	Limit (dB μ V/m)	Margin (dB)	Detector	Polarization
*	7184.7	34.0	13.6	47.6	68.2	-20.6	Peak	Horizontal
*	8015.5	34.5	15.1	49.6	68.2	-18.6	Peak	Horizontal
	9418.3	35.3	15.5	50.8	74.0	-23.2	Peak	Horizontal
	11803.5	32.9	19.3	52.2	74.0	-21.8	Peak	Horizontal
*	7048.7	35.7	13.1	48.8	68.2	-19.4	Peak	Vertical
*	8512.6	34.7	14.6	49.3	68.2	-18.9	Peak	Vertical
	9472.5	35.7	15.4	51.1	74.0	-22.9	Peak	Vertical
	11914.0	33.6	19.6	53.2	74.0	-20.8	Peak	Vertical

Note 1: "*" is not in restricted band, its limit is -27dBm/MHz. At a distance of 3 meters, the field strength limit in dB μ V/m can be determined by adding a "conversion" factor of 95.2dB to the EIRP limit of -27dBm/MHz to obtain the limit for out of band spurious emissions of 68.2dB μ V/m.

Note 2: Measure Level (dB μ V/m) = Reading Level (dB μ V) + Factor (dB)

Factor (dB) = Cable Loss (dB) + Antenna Factor (dB/m) - Pre_Amplifier Gain (dB)

Test Mode:	802.11ac-VHT20	Test Site:	AC1
Test Channel:	48	Test Engineer:	Roy Cheng
Remark:	1. Average measurement was not performed if peak level lower than average limit. 2. Other frequency was 20dB below limit line within 1-18GHz, there is not show in the report.		

Mark	Frequency (MHz)	Reading Level (dB μ V)	Factor (dB)	Measure Level (dB μ V/m)	Limit (dB μ V/m)	Margin (dB)	Detector	Polarization
*	7204.9	34.9	13.6	48.5	68.2	-19.7	Peak	Horizontal
*	8543.7	34.0	14.5	48.5	68.2	-19.7	Peak	Horizontal
	9173.5	35.5	15.3	50.8	74.0	-23.2	Peak	Horizontal
	12407.0	34.4	19.0	53.4	74.0	-20.6	Peak	Horizontal
*	7173.7	34.5	13.6	48.1	68.2	-20.1	Peak	Vertical
*	8517.6	35.1	14.6	49.7	68.2	-18.5	Peak	Vertical
	9173.6	35.0	15.3	50.3	74.0	-23.7	Peak	Vertical
	12475.0	33.8	19.6	53.4	74.0	-20.6	Peak	Vertical

Note 1: "*" is not in restricted band, its limit is -27dBm/MHz. At a distance of 3 meters, the field strength limit in dB μ V/m can be determined by adding a "conversion" factor of 95.2dB to the EIRP limit of -27dBm/MHz to obtain the limit for out of band spurious emissions of 68.2dB μ V/m.

Note 2: Measure Level (dB μ V/m) = Reading Level (dB μ V) + Factor (dB)

Factor (dB) = Cable Loss (dB) + Antenna Factor (dB/m) - Pre_Amplifier Gain (dB)

Test Mode:	802.11ac-VHT20	Test Site:	AC1
Test Channel:	52	Test Engineer:	Roy Cheng
Remark:	1. Average measurement was not performed if peak level lower than average limit. 2. Other frequency was 20dB below limit line within 1-18GHz, there is not show in the report.		

Mark	Frequency (MHz)	Reading Level (dB μ V)	Factor (dB)	Measure Level (dB μ V/m)	Limit (dB μ V/m)	Margin (dB)	Detector	Polarization
*	7172.5	34.8	13.6	48.4	68.2	-19.8	Peak	Horizontal
*	10520.0	40.1	17.9	58.0	68.2	-10.2	Peak	Horizontal
	11803.5	33.0	19.3	52.3	74.0	-21.7	Peak	Horizontal
	12466.5	33.6	19.7	53.3	74.0	-20.7	Peak	Horizontal
*	7009.5	40.2	12.8	53.0	68.2	-15.2	Peak	Vertical
*	8472.5	35.6	14.6	50.2	68.2	-18.0	Peak	Vertical
	9418.7	35.6	15.5	51.1	74.0	-22.9	Peak	Vertical
	11854.5	33.5	19.5	53.0	74.0	-21.0	Peak	Vertical

Note 1: "*" is not in restricted band, its limit is -27dBm/MHz. At a distance of 3 meters, the field strength limit in dB μ V/m can be determined by adding a "conversion" factor of 95.2dB to the EIRP limit of -27dBm/MHz to obtain the limit for out of band spurious emissions of 68.2dB μ V/m.

Note 2: Measure Level (dB μ V/m) = Reading Level (dB μ V) + Factor (dB)

Factor (dB) = Cable Loss (dB) + Antenna Factor (dB/m) - Pre_Amplifier Gain (dB)

Test Mode:	802.11ac-VHT20	Test Site:	AC1
Test Channel:	60	Test Engineer:	Roy Cheng
Remark:	1. Average measurement was not performed if peak level lower than average limit. 2. Other frequency was 20dB below limit line within 1-18GHz, there is not show in the report.		

Mark	Frequency (MHz)	Reading Level (dB μ V)	Factor (dB)	Measure Level (dB μ V/m)	Limit (dB μ V/m)	Margin (dB)	Detector	Polarization
*	7025.5	36.1	12.9	49.0	68.2	-19.2	Peak	Horizontal
*	8672.5	34.3	14.8	49.1	68.2	-19.1	Peak	Horizontal
	9402.7	35.6	15.4	51.0	74.0	-23.0	Peak	Horizontal
	11319.0	34.0	19.1	53.1	74.0	-20.9	Peak	Horizontal
*	7025.7	35.3	12.9	48.2	68.2	-20.0	Peak	Vertical
*	8414.7	34.9	14.5	49.4	68.2	-18.8	Peak	Vertical
	10600.0	38.3	17.8	56.1	74.0	-17.9	Peak	Vertical
	10605.5	27.0	17.8	44.8	54.0	-9.2	Peak	Vertical

Note 1: "*" is not in restricted band, its limit is -27dBm/MHz. At a distance of 3 meters, the field strength limit in dB μ V/m can be determined by adding a "conversion" factor of 95.2dB to the EIRP limit of -27dBm/MHz to obtain the limit for out of band spurious emissions of 68.2dB μ V/m.

Note 2: Measure Level (dB μ V/m) = Reading Level (dB μ V) + Factor (dB)

Factor (dB) = Cable Loss (dB) + Antenna Factor (dB/m) - Pre_Amplifier Gain (dB)

Test Mode:	802.11ac-VHT20	Test Site:	AC1
Test Channel:	64	Test Engineer:	Roy Cheng
Remark:	1. Average measurement was not performed if peak level lower than average limit. 2. Other frequency was 20dB below limit line within 1-18GHz, there is not show in the report.		

Mark	Frequency (MHz)	Reading Level (dB μ V)	Factor (dB)	Measure Level (dB μ V/m)	Limit (dB μ V/m)	Margin (dB)	Detector	Polarization
*	7025.7	36.2	12.9	49.1	68.2	-19.1	Peak	Horizontal
*	8502.7	35.6	14.7	50.3	68.2	-17.9	Peak	Horizontal
	9415.7	37.1	15.5	52.6	74.0	-21.4	Peak	Horizontal
	10698.5	35.2	17.7	52.9	74.0	-21.1	Peak	Horizontal
*	7149.8	34.3	13.5	47.8	68.2	-20.4	Peak	Vertical
*	8472.0	34.5	14.6	49.1	68.2	-19.1	Peak	Vertical
	9402.5	35.6	15.4	51.0	74.0	-23.0	Peak	Vertical
	10690.0	34.1	17.6	51.7	74.0	-22.3	Peak	Vertical

Note 1: "*" is not in restricted band, its limit is -27dBm/MHz. At a distance of 3 meters, the field strength limit in dB μ V/m can be determined by adding a "conversion" factor of 95.2dB to the EIRP limit of -27dBm/MHz to obtain the limit for out of band spurious emissions of 68.2dB μ V/m.

Note 2: Measure Level (dB μ V/m) = Reading Level (dB μ V) + Factor (dB)

Factor (dB) = Cable Loss (dB) + Antenna Factor (dB/m) - Pre_Amplifier Gain (dB)

Test Mode:	802.11ac-VHT20	Test Site:	AC1
Test Channel:	100	Test Engineer:	Roy Cheng
Remark:	1. Average measurement was not performed if peak level lower than average limit. 2. Other frequency was 20dB below limit line within 1-18GHz, there is not show in the report.		

Mark	Frequency (MHz)	Reading Level (dB μ V)	Factor (dB)	Measure Level (dB μ V/m)	Limit (dB μ V/m)	Margin (dB)	Detector	Polarization
*	7024.6	35.5	12.9	48.4	68.2	-19.8	Peak	Horizontal
*	8472.2	34.7	14.6	49.3	68.2	-18.9	Peak	Horizontal
	9408.5	36.0	15.5	51.5	74.0	-22.5	Peak	Horizontal
	11319.0	33.5	19.1	52.6	74.0	-21.4	Peak	Horizontal
*	7142.6	34.4	13.5	47.9	68.2	-20.3	Peak	Vertical
*	8514.7	34.8	14.6	49.4	68.2	-18.8	Peak	Vertical
	9410.9	35.0	15.5	50.5	74.0	-23.5	Peak	Vertical
	10690.0	33.8	17.6	51.4	74.0	-22.6	Peak	Vertical

Note 1: "*" is not in restricted band, its limit is -27dBm/MHz. At a distance of 3 meters, the field strength limit in dB μ V/m can be determined by adding a "conversion" factor of 95.2dB to the EIRP limit of -27dBm/MHz to obtain the limit for out of band spurious emissions of 68.2dB μ V/m.

Note 2: Measure Level (dB μ V/m) = Reading Level (dB μ V) + Factor (dB)

Factor (dB) = Cable Loss (dB) + Antenna Factor (dB/m) - Pre_Amplifier Gain (dB)

Test Mode:	802.11ac-VHT20	Test Site:	AC1
Test Channel:	116	Test Engineer:	Roy Cheng
Remark:	1. Average measurement was not performed if peak level lower than average limit. 2. Other frequency was 20dB below limit line within 1-18GHz, there is not show in the report.		

Mark	Frequency (MHz)	Reading Level (dB μ V)	Factor (dB)	Measure Level (dB μ V/m)	Limit (dB μ V/m)	Margin (dB)	Detector	Polarization
*	7204.8	35.3	13.6	48.9	68.2	-19.3	Peak	Horizontal
*	8518.0	34.5	14.6	49.1	68.2	-19.1	Peak	Horizontal
	9467.5	35.8	15.4	51.2	74.0	-22.8	Peak	Horizontal
	11276.5	34.0	18.8	52.8	74.0	-21.2	Peak	Horizontal
*	7194.7	34.1	13.6	47.7	68.2	-20.5	Peak	Vertical
*	7953.5	33.8	15.1	48.9	68.2	-19.3	Peak	Vertical
	9134.5	35.3	15.1	50.4	74.0	-23.6	Peak	Vertical
	11905.5	33.3	19.5	52.8	74.0	-21.2	Peak	Vertical

Note 1: "*" is not in restricted band, its limit is -27dBm/MHz. At a distance of 3 meters, the field strength limit in dB μ V/m can be determined by adding a "conversion" factor of 95.2dB to the EIRP limit of -27dBm/MHz to obtain the limit for out of band spurious emissions of 68.2dB μ V/m.

Note 2: Measure Level (dB μ V/m) = Reading Level (dB μ V) + Factor (dB)

Factor (dB) = Cable Loss (dB) + Antenna Factor (dB/m) - Pre_Amplifier Gain (dB)

Test Mode:	802.11ac-VHT20	Test Site:	AC1
Test Channel:	140	Test Engineer:	Roy Cheng
Remark:	1. Average measurement was not performed if peak level lower than average limit. 2. Other frequency was 20dB below limit line within 1-18GHz, there is not show in the report.		

Mark	Frequency (MHz)	Reading Level (dB μ V)	Factor (dB)	Measure Level (dB μ V/m)	Limit (dB μ V/m)	Margin (dB)	Detector	Polarization
*	7143.6	34.0	13.5	47.5	68.2	-20.7	Peak	Horizontal
*	8572.6	34.4	14.5	48.9	68.2	-19.3	Peak	Horizontal
	9173.5	34.8	15.3	50.1	74.0	-23.9	Peak	Horizontal
	11276.5	33.5	18.8	52.3	74.0	-21.7	Peak	Horizontal
*	7102.6	34.5	13.4	47.9	68.2	-20.3	Peak	Vertical
*	8526.5	33.8	14.6	48.4	68.2	-19.8	Peak	Vertical
	9426.7	35.3	15.5	50.8	74.0	-23.2	Peak	Vertical
	11803.5	33.0	19.3	52.3	74.0	-21.7	Peak	Vertical

Note 1: "*" is not in restricted band, its limit is -27dBm/MHz. At a distance of 3 meters, the field strength limit in dB μ V/m can be determined by adding a "conversion" factor of 95.2dB to the EIRP limit of -27dBm/MHz to obtain the limit for out of band spurious emissions of 68.2dB μ V/m.

Note 2: Measure Level (dB μ V/m) = Reading Level (dB μ V) + Factor (dB)

Factor (dB) = Cable Loss (dB) + Antenna Factor (dB/m) - Pre_Amplifier Gain (dB)

Test Mode:	802.11ac-VHT20	Test Site:	AC1
Test Channel:	144	Test Engineer:	Roy Cheng
Remark:	1. Average measurement was not performed if peak level lower than average limit. 2. Other frequency was 20dB below limit line within 1-18GHz, there is not show in the report.		

Mark	Frequency (MHz)	Reading Level (dB μ V)	Factor (dB)	Measure Level (dB μ V/m)	Limit (dB μ V/m)	Margin (dB)	Detector	Polarization
*	7146.4	34.9	13.5	48.4	68.2	-19.8	Peak	Horizontal
*	8562.5	34.7	14.4	49.1	68.2	-19.1	Peak	Horizontal
	9426.6	35.5	15.5	51.0	74.0	-23.0	Peak	Horizontal
	11276.5	33.6	18.8	52.4	74.0	-21.6	Peak	Horizontal
*	7045.7	35.4	13.1	48.5	68.2	-19.7	Peak	Vertical
*	8413.6	34.1	14.5	48.6	68.2	-19.6	Peak	Vertical
	9402.7	35.5	15.4	50.9	74.0	-23.1	Peak	Vertical
	11812.0	32.5	19.3	51.8	74.0	-22.2	Peak	Vertical

Note 1: "*" is not in restricted band, its limit is -27dBm/MHz. At a distance of 3 meters, the field strength limit in dB μ V/m can be determined by adding a "conversion" factor of 95.2dB to the EIRP limit of -27dBm/MHz to obtain the limit for out of band spurious emissions of 68.2dB μ V/m.

Note 2: Measure Level (dB μ V/m) = Reading Level (dB μ V) + Factor (dB)

Factor (dB) = Cable Loss (dB) + Antenna Factor (dB/m) - Pre_Amplifier Gain (dB)

Test Mode:	802.11n-HT40	Test Site:	AC1
Test Channel:	38	Test Engineer:	Roy Cheng
Remark:	1. Average measurement was not performed if peak level lower than average limit. 2. Other frequency was 20dB below limit line within 1-18GHz, there is not show in the report.		

Mark	Frequency (MHz)	Reading Level (dB μ V)	Factor (dB)	Measure Level (dB μ V/m)	Limit (dB μ V/m)	Margin (dB)	Detector	Polarization
*	7126.5	34.9	13.5	48.4	68.2	-19.8	Peak	Horizontal
*	8536.5	34.4	14.5	48.9	68.2	-19.3	Peak	Horizontal
	9402.5	35.5	15.4	50.9	74.0	-23.1	Peak	Horizontal
	11803.5	33.1	19.3	52.4	74.0	-21.6	Peak	Horizontal
*	7044.0	35.9	13.1	49.0	68.2	-19.2	Peak	Vertical
*	7760.5	34.3	14.8	49.1	68.2	-19.1	Peak	Vertical
	9372.2	36.6	15.3	51.9	74.0	-22.1	Peak	Vertical
	12424.0	33.8	19.2	53.0	74.0	-21.0	Peak	Vertical

Note 1: "*" is not in restricted band, its limit is -27dBm/MHz. At a distance of 3 meters, the field strength limit in dB μ V/m can be determined by adding a "conversion" factor of 95.2dB to the EIRP limit of -27dBm/MHz to obtain the limit for out of band spurious emissions of 68.2dB μ V/m.

Note 2: Measure Level (dB μ V/m) = Reading Level (dB μ V) + Factor (dB)

Factor (dB) = Cable Loss (dB) + Antenna Factor (dB/m) - Pre_Amplifier Gain (dB)

Test Mode:	802.11n-HT40	Test Site:	AC1
Test Channel:	46	Test Engineer:	Roy Cheng
Remark:	1. Average measurement was not performed if peak level lower than average limit. 2. Other frequency was 20dB below limit line within 1-18GHz, there is not show in the report.		

Mark	Frequency (MHz)	Reading Level (dB μ V)	Factor (dB)	Measure Level (dB μ V/m)	Limit (dB μ V/m)	Margin (dB)	Detector	Polarization
*	7215.5	34.6	13.7	48.3	68.2	-19.9	Peak	Horizontal
*	8925.5	35.2	14.3	49.5	68.2	-18.7	Peak	Horizontal
	9412.5	35.3	15.5	50.8	74.0	-23.2	Peak	Horizontal
	11812.0	32.7	19.3	52.0	74.0	-22.0	Peak	Horizontal
*	7002.5	35.2	12.7	47.9	68.2	-20.3	Peak	Vertical
*	8572.7	33.6	14.5	48.1	68.2	-20.1	Peak	Vertical
	9415.6	35.8	15.5	51.3	74.0	-22.7	Peak	Vertical
	11795.0	33.8	19.4	53.2	74.0	-20.8	Peak	Vertical

Note 1: "*" is not in restricted band, its limit is -27dBm/MHz. At a distance of 3 meters, the field strength limit in dB μ V/m can be determined by adding a "conversion" factor of 95.2dB to the EIRP limit of -27dBm/MHz to obtain the limit for out of band spurious emissions of 68.2dB μ V/m.

Note 2: Measure Level (dB μ V/m) = Reading Level (dB μ V) + Factor (dB)

Factor (dB) = Cable Loss (dB) + Antenna Factor (dB/m) - Pre_Amplifier Gain (dB)

Test Mode:	802.11n-HT40	Test Site:	AC1
Test Channel:	54	Test Engineer:	Roy Cheng
Remark:	1. Average measurement was not performed if peak level lower than average limit. 2. Other frequency was 20dB below limit line within 1-18GHz, there is not show in the report.		

Mark	Frequency (MHz)	Reading Level (dB μ V)	Factor (dB)	Measure Level (dB μ V/m)	Limit (dB μ V/m)	Margin (dB)	Detector	Polarization
*	7183.6	33.9	13.6	47.5	68.2	-20.7	Peak	Horizontal
*	8672.6	34.2	14.8	49.0	68.2	-19.2	Peak	Horizontal
	9173.5	35.2	15.3	50.5	74.0	-23.5	Peak	Horizontal
	11795.0	33.3	19.4	52.7	74.0	-21.3	Peak	Horizontal
*	7102.5	34.6	13.4	48.0	68.2	-20.2	Peak	Vertical
*	8512.5	34.4	14.6	49.0	68.2	-19.2	Peak	Vertical
	9373.6	35.0	15.3	50.3	74.0	-23.7	Peak	Vertical
*	11803.5	32.8	19.3	52.1	74.0	-21.9	Peak	Horizontal

Note 1: "*" is not in restricted band, its limit is -27dBm/MHz. At a distance of 3 meters, the field strength limit in dB μ V/m can be determined by adding a "conversion" factor of 95.2dB to the EIRP limit of -27dBm/MHz to obtain the limit for out of band spurious emissions of 68.2dB μ V/m.

Note 2: Measure Level (dB μ V/m) = Reading Level (dB μ V) + Factor (dB)

Factor (dB) = Cable Loss (dB) + Antenna Factor (dB/m) - Pre_Amplifier Gain (dB)

Test Mode:	802.11n-HT40	Test Site:	AC1
Test Channel:	62	Test Engineer:	Roy Cheng
Remark:	1. Average measurement was not performed if peak level lower than average limit. 2. Other frequency was 20dB below limit line within 1-18GHz, there is not show in the report.		

Mark	Frequency (MHz)	Reading Level (dB μ V)	Factor (dB)	Measure Level (dB μ V/m)	Limit (dB μ V/m)	Margin (dB)	Detector	Polarization
*	7002.7	35.2	12.7	47.9	68.2	-20.3	Peak	Horizontal
*	8536.5	34.8	14.5	49.3	68.2	-18.9	Peak	Horizontal
	9402.9	35.6	15.4	51.0	74.0	-23.0	Peak	Horizontal
	11803.5	33.0	19.3	52.3	74.0	-21.7	Peak	Horizontal
*	7002.5	34.8	12.7	47.5	68.2	-20.7	Peak	Vertical
*	8635.8	34.0	14.8	48.8	68.2	-19.4	Peak	Vertical
	9482.5	35.0	15.4	50.4	74.0	-23.6	Peak	Vertical
	11803.5	33.4	19.3	52.7	74.0	-21.3	Peak	Vertical

Note 1: "*" is not in restricted band, its limit is -27dBm/MHz. At a distance of 3 meters, the field strength limit in dB μ V/m can be determined by adding a "conversion" factor of 95.2dB to the EIRP limit of -27dBm/MHz to obtain the limit for out of band spurious emissions of 68.2dB μ V/m.

Note 2: Measure Level (dB μ V/m) = Reading Level (dB μ V) + Factor (dB)

Factor (dB) = Cable Loss (dB) + Antenna Factor (dB/m) - Pre_Amplifier Gain (dB)

Test Mode:	802.11n-HT40	Test Site:	AC1
Test Channel:	102	Test Engineer:	Roy Cheng
Remark:	1. Average measurement was not performed if peak level lower than average limit. 2. Other frequency was 20dB below limit line within 1-18GHz, there is not show in the report.		

Mark	Frequency (MHz)	Reading Level (dB μ V)	Factor (dB)	Measure Level (dB μ V/m)	Limit (dB μ V/m)	Margin (dB)	Detector	Polarization
*	7155.7	34.2	13.6	47.8	68.2	-20.4	Peak	Horizontal
*	8615.5	33.4	14.8	48.2	68.2	-20.0	Peak	Horizontal
	9412.5	35.3	15.5	50.8	74.0	-23.2	Peak	Horizontal
	11013.0	38.1	18.8	56.9	74.0	-17.1	Peak	Horizontal
*	11020.0	25.7	18.8	44.5	54.0	-9.5	Peak	Vertical
*	7125.7	34.7	13.5	48.2	68.2	-20.0	Peak	Vertical
	8512.7	35.1	14.6	49.7	68.2	-18.5	Peak	Vertical
	9105.4	34.5	14.6	49.1	74.0	-24.9	Peak	Vertical

Note 1: "*" is not in restricted band, its limit is -27dBm/MHz. At a distance of 3 meters, the field strength limit in dB μ V/m can be determined by adding a "conversion" factor of 95.2dB to the EIRP limit of -27dBm/MHz to obtain the limit for out of band spurious emissions of 68.2dB μ V/m.

Note 2: Measure Level (dB μ V/m) = Reading Level (dB μ V) + Factor (dB)

Factor (dB) = Cable Loss (dB) + Antenna Factor (dB/m) - Pre_Amplifier Gain (dB)

Test Mode:	802.11n-HT40	Test Site:	AC1
Test Channel:	118	Test Engineer:	Roy Cheng
Remark:	1. Average measurement was not performed if peak level lower than average limit. 2. Other frequency was 20dB below limit line within 1-18GHz, there is not show in the report.		

Mark	Frequency (MHz)	Reading Level (dB μ V)	Factor (dB)	Measure Level (dB μ V/m)	Limit (dB μ V/m)	Margin (dB)	Detector	Polarization
*	7145.7	34.5	13.5	48.0	68.2	-20.2	Peak	Horizontal
*	8512.1	34.7	14.6	49.3	68.2	-18.9	Peak	Horizontal
	9473.5	35.8	15.4	51.2	74.0	-22.8	Peak	Horizontal
	11276.5	33.6	18.8	52.4	74.0	-21.6	Peak	Horizontal
*	7025.6	35.2	12.9	48.1	68.2	-20.1	Peak	Vertical
*	8524.9	34.3	14.6	48.9	68.2	-19.3	Peak	Vertical
	9483.5	36.6	15.4	52.0	74.0	-22.0	Peak	Vertical
	11812.0	33.1	19.3	52.4	74.0	-21.6	Peak	Vertical

Note 1: "*" is not in restricted band, its limit is -27dBm/MHz. At a distance of 3 meters, the field strength limit in dB μ V/m can be determined by adding a "conversion" factor of 95.2dB to the EIRP limit of -27dBm/MHz to obtain the limit for out of band spurious emissions of 68.2dB μ V/m.

Note 2: Measure Level (dB μ V/m) = Reading Level (dB μ V) + Factor (dB)

Factor (dB) = Cable Loss (dB) + Antenna Factor (dB/m) - Pre_Amplifier Gain (dB)

Test Mode:	802.11n-HT40	Test Site:	AC1
Test Channel:	134	Test Engineer:	Roy Cheng
Remark:	1. Average measurement was not performed if peak level lower than average limit. 2. Other frequency was 20dB below limit line within 1-18GHz, there is not show in the report.		

Mark	Frequency (MHz)	Reading Level (dB μ V)	Factor (dB)	Measure Level (dB μ V/m)	Limit (dB μ V/m)	Margin (dB)	Detector	Polarization
*	7202.4	34.1	13.6	47.7	68.2	-20.5	Peak	Horizontal
*	8536.5	33.7	14.5	48.2	68.2	-20.0	Peak	Horizontal
	9472.7	35.9	15.4	51.3	74.0	-22.7	Peak	Horizontal
	11803.5	33.0	19.3	52.3	74.0	-21.7	Peak	Horizontal
*	7146.5	34.2	13.5	47.7	68.2	-20.5	Peak	Vertical
*	8573.5	33.6	14.5	48.1	68.2	-20.1	Peak	Vertical
	9174.4	35.4	15.3	50.7	74.0	-23.3	Peak	Vertical
	12067.0	33.8	19.2	53.0	74.0	-21.0	Average	Vertical
	7202.4	34.1	13.6	47.7	68.2	-20.5	Peak	Vertical

Note 1: "*" is not in restricted band, its limit is -27dBm/MHz. At a distance of 3 meters, the field strength limit in dB μ V/m can be determined by adding a "conversion" factor of 95.2dB to the EIRP limit of -27dBm/MHz to obtain the limit for out of band spurious emissions of 68.2dB μ V/m.

Note 2: Measure Level (dB μ V/m) = Reading Level (dB μ V) + Factor (dB)

Factor (dB) = Cable Loss (dB) + Antenna Factor (dB/m) - Pre_Amplifier Gain (dB)

Test Mode:	802.11ac-VHT40	Test Site:	AC1
Test Channel:	38	Test Engineer:	Roy Cheng
Remark:	1. Average measurement was not performed if peak level lower than average limit. 2. Other frequency was 20dB below limit line within 1-18GHz, there is not show in the report.		

Mark	Frequency (MHz)	Reading Level (dB μ V)	Factor (dB)	Measure Level (dB μ V/m)	Limit (dB μ V/m)	Margin (dB)	Detector	Polarization
*	7173.6	34.1	13.6	47.7	68.2	-20.5	Peak	Horizontal
*	8592.6	33.9	14.8	48.7	68.2	-19.5	Peak	Horizontal
	9403.5	35.0	15.4	50.4	74.0	-23.6	Peak	Horizontal
	11803.5	32.9	19.3	52.2	74.0	-21.8	Peak	Horizontal
*	7146.6	34.2	13.5	47.7	68.2	-20.5	Peak	Vertical
*	8535.3	34.1	14.5	48.6	68.2	-19.6	Peak	Vertical
	9125.6	35.2	14.9	50.1	74.0	-23.9	Peak	Vertical
	11803.5	33.2	19.3	52.5	74.0	-21.5	Peak	Vertical

Note 1: "*" is not in restricted band, its limit is -27dBm/MHz. At a distance of 3 meters, the field strength limit in dB μ V/m can be determined by adding a "conversion" factor of 95.2dB to the EIRP limit of -27dBm/MHz to obtain the limit for out of band spurious emissions of 68.2dB μ V/m.

Note 2: Measure Level (dB μ V/m) = Reading Level (dB μ V) + Factor (dB)

Factor (dB) = Cable Loss (dB) + Antenna Factor (dB/m) - Pre_Amplifier Gain (dB)

Test Mode:	802.11ac-VHT40	Test Site:	AC1
Test Channel:	46	Test Engineer:	Roy Cheng
Remark:	1. Average measurement was not performed if peak level lower than average limit. 2. Other frequency was 20dB below limit line within 1-18GHz, there is not show in the report.		

Mark	Frequency (MHz)	Reading Level (dB μ V)	Factor (dB)	Measure Level (dB μ V/m)	Limit (dB μ V/m)	Margin (dB)	Detector	Polarization
*	7146.6	34.8	13.5	48.3	68.2	-19.9	Peak	Horizontal
*	8572.5	34.0	14.5	48.5	68.2	-19.7	Peak	Horizontal
	9173.5	34.8	15.3	50.1	74.0	-23.9	Peak	Horizontal
	12067.0	33.9	19.2	53.1	74.0	-20.9	Peak	Horizontal
*	7045.7	35.5	13.1	48.6	68.2	-19.6	Peak	Vertical
*	7983.6	34.3	15.0	49.3	68.2	-18.9	Peak	Vertical
	9183.5	35.7	15.3	51.0	74.0	-23.0	Peak	Vertical
	11803.5	32.6	19.3	51.9	74.0	-22.1	Peak	Vertical

Note 1: "*" is not in restricted band, its limit is -27dBm/MHz. At a distance of 3 meters, the field strength limit in dB μ V/m can be determined by adding a "conversion" factor of 95.2dB to the EIRP limit of -27dBm/MHz to obtain the limit for out of band spurious emissions of 68.2dB μ V/m.

Note 2: Measure Level (dB μ V/m) = Reading Level (dB μ V) + Factor (dB)

Factor (dB) = Cable Loss (dB) + Antenna Factor (dB/m) - Pre_Amplifier Gain (dB)

Test Mode:	802.11ac-VHT40	Test Site:	AC1
Test Channel:	54	Test Engineer:	Roy Cheng
Remark:	1. Average measurement was not performed if peak level lower than average limit. 2. Other frequency was 20dB below limit line within 1-18GHz, there is not show in the report.		

Mark	Frequency (MHz)	Reading Level (dBμV)	Factor (dB)	Measure Level (dBμV/m)	Limit (dBμV/m)	Margin (dB)	Detector	Polarization
*	7125.7	35.0	13.5	48.5	68.2	-19.7	Peak	Horizontal
*	8513.7	34.4	14.6	49.0	68.2	-19.2	Peak	Horizontal
	9402.5	35.3	15.4	50.7	74.0	-23.3	Peak	Horizontal
	11276.5	33.7	18.8	52.5	74.0	-21.5	Peak	Horizontal
*	7026.5	39.2	12.9	52.1	68.2	-16.1	Peak	Vertical
*	8545.5	33.8	14.5	48.3	68.2	-19.9	Peak	Vertical
	9368.5	35.4	15.3	50.7	74.0	-23.3	Peak	Vertical
	11812.0	32.9	19.3	52.2	74.0	-21.8	Peak	Vertical

Note 1: "*" is not in restricted band, its limit is -27dBm/MHz. At a distance of 3 meters, the field strength limit in dBμV/m can be determined by adding a "conversion" factor of 95.2dB to the EIRP limit of -27dBm/MHz to obtain the limit for out of band spurious emissions of 68.2dBμV/m.

Note 2: Measure Level (dBμV/m) = Reading Level (dBμV) + Factor (dB)

Factor (dB) = Cable Loss (dB) + Antenna Factor (dB/m) - Pre_Amplifier Gain (dB)

Test Mode:	802.11ac-VHT40	Test Site:	AC1
Test Channel:	62	Test Engineer:	Roy Cheng
Remark:	1. Average measurement was not performed if peak level lower than average limit. 2. Other frequency was 20dB below limit line within 1-18GHz, there is not show in the report.		

Mark	Frequency (MHz)	Reading Level (dB μ V)	Factor (dB)	Measure Level (dB μ V/m)	Limit (dB μ V/m)	Margin (dB)	Detector	Polarization
*	7024.7	35.8	12.9	48.7	68.2	-19.5	Peak	Horizontal
*	8515.7	34.3	14.6	48.9	68.2	-19.3	Peak	Horizontal
	9415.9	35.5	15.5	51.0	74.0	-23.0	Peak	Horizontal
	11769.5	33.7	19.4	53.1	74.0	-20.9	Peak	Horizontal
*	7077.5	38.3	13.2	51.5	68.2	-16.7	Peak	Vertical
*	8012.6	34.0	15.1	49.1	68.2	-19.1	Peak	Vertical
	9392.6	35.1	15.4	50.5	74.0	-23.5	Peak	Vertical
	11268.0	34.1	18.8	52.9	74.0	-21.1	Peak	Vertical

Note 1: "*" is not in restricted band, its limit is -27dBm/MHz. At a distance of 3 meters, the field strength limit in dB μ V/m can be determined by adding a "conversion" factor of 95.2dB to the EIRP limit of -27dBm/MHz to obtain the limit for out of band spurious emissions of 68.2dB μ V/m.

Note 2: Measure Level (dB μ V/m) = Reading Level (dB μ V) + Factor (dB)

Factor (dB) = Cable Loss (dB) + Antenna Factor (dB/m) - Pre_Amplifier Gain (dB)

Test Mode:	802.11ac-VHT40	Test Site:	AC1
Test Channel:	102	Test Engineer:	Roy Cheng
Remark:	1. Average measurement was not performed if peak level lower than average limit. 2. Other frequency was 20dB below limit line within 1-18GHz, there is not show in the report.		

Mark	Frequency (MHz)	Reading Level (dB μ V)	Factor (dB)	Measure Level (dB μ V/m)	Limit (dB μ V/m)	Margin (dB)	Detector	Polarization
*	7146.2	34.1	13.5	47.6	68.2	-20.6	Peak	Horizontal
*	7965.5	34.9	15.0	49.9	68.2	-18.3	Peak	Horizontal
	9470.5	35.4	15.4	50.8	74.0	-23.2	Peak	Horizontal
	12398.5	34.4	19.0	53.4	74.0	-20.6	Peak	Horizontal
*	7143.9	34.0	13.5	47.5	68.2	-20.7	Peak	Vertical
*	8572.5	34.4	14.5	48.9	68.2	-19.3	Peak	Vertical
	9471.6	36.1	15.4	51.5	74.0	-22.5	Peak	Vertical
	12398.5	34.1	19.0	53.1	74.0	-20.9	Peak	Vertical

Note 1: "*" is not in restricted band, its limit is -27dBm/MHz. At a distance of 3 meters, the field strength limit in dB μ V/m can be determined by adding a "conversion" factor of 95.2dB to the EIRP limit of -27dBm/MHz to obtain the limit for out of band spurious emissions of 68.2dB μ V/m.

Note 2: Measure Level (dB μ V/m) = Reading Level (dB μ V) + Factor (dB)

Factor (dB) = Cable Loss (dB) + Antenna Factor (dB/m) - Pre_Amplifier Gain (dB)

Test Mode:	802.11ac-VHT40	Test Site:	AC1
Test Channel:	118	Test Engineer:	Roy Cheng
Remark:	1. Average measurement was not performed if peak level lower than average limit. 2. Other frequency was 20dB below limit line within 1-18GHz, there is not show in the report.		

Mark	Frequency (MHz)	Reading Level (dB μ V)	Factor (dB)	Measure Level (dB μ V/m)	Limit (dB μ V/m)	Margin (dB)	Detector	Polarization
*	7249.7	34.2	13.8	48.0	68.2	-20.2	Peak	Horizontal
*	8571.5	33.7	14.5	48.2	68.2	-20.0	Peak	Horizontal
	9471.2	35.5	15.4	50.9	74.0	-23.1	Peak	Horizontal
	11812.0	33.0	19.3	52.3	74.0	-21.7	Peak	Horizontal
*	7205.0	34.5	13.6	48.1	68.2	-20.1	Peak	Vertical
*	8010.6	34.6	15.1	49.7	68.2	-18.5	Peak	Vertical
	9173.7	35.0	15.3	50.3	74.0	-23.7	Peak	Vertical
	11914.0	33.1	19.6	52.7	74.0	-21.3	Peak	Vertical

Note 1: "*" is not in restricted band, its limit is -27dBm/MHz. At a distance of 3 meters, the field strength limit in dB μ V/m can be determined by adding a "conversion" factor of 95.2dB to the EIRP limit of -27dBm/MHz to obtain the limit for out of band spurious emissions of 68.2dB μ V/m.

Note 2: Measure Level (dB μ V/m) = Reading Level (dB μ V) + Factor (dB)

Factor (dB) = Cable Loss (dB) + Antenna Factor (dB/m) - Pre_Amplifier Gain (dB)

Test Mode:	802.11ac-VHT40	Test Site:	AC1
Test Channel:	134	Test Engineer:	Roy Cheng
Remark:	1. Average measurement was not performed if peak level lower than average limit. 2. Other frequency was 20dB below limit line within 1-18GHz, there is not show in the report.		

Mark	Frequency (MHz)	Reading Level (dB μ V)	Factor (dB)	Measure Level (dB μ V/m)	Limit (dB μ V/m)	Margin (dB)	Detector	Polarization
*	7253.7	34.5	13.9	48.4	68.2	-19.8	Peak	Horizontal
*	8542.7	33.8	14.5	48.3	68.2	-19.9	Peak	Horizontal
	9152.5	34.4	15.3	49.7	74.0	-24.3	Peak	Horizontal
	11276.5	33.8	18.8	52.6	74.0	-21.4	Peak	Horizontal
*	7153.7	33.5	13.6	47.1	68.2	-21.1	Peak	Vertical
*	8572.5	34.1	14.5	48.6	68.2	-19.6	Peak	Vertical
	9473.5	35.3	15.4	50.7	74.0	-23.3	Peak	Vertical
	11276.5	33.5	18.8	52.3	74.0	-21.7	Peak	Vertical

Note 1: "*" is not in restricted band, its limit is -27dBm/MHz. At a distance of 3 meters, the field strength limit in dB μ V/m can be determined by adding a "conversion" factor of 95.2dB to the EIRP limit of -27dBm/MHz to obtain the limit for out of band spurious emissions of 68.2dB μ V/m.

Note 2: Measure Level (dB μ V/m) = Reading Level (dB μ V) + Factor (dB)

Factor (dB) = Cable Loss (dB) + Antenna Factor (dB/m) - Pre_Amplifier Gain (dB)

Test Mode:	802.11ac-VHT40	Test Site:	AC1
Test Channel:	142	Test Engineer:	Roy Cheng
Remark:	1. Average measurement was not performed if peak level lower than average limit. 2. Other frequency was 20dB below limit line within 1-18GHz, there is not show in the report.		

Mark	Frequency (MHz)	Reading Level (dB μ V)	Factor (dB)	Measure Level (dB μ V/m)	Limit (dB μ V/m)	Margin (dB)	Detector	Polarization
*	7183.9	33.9	13.6	47.5	68.2	-20.7	Peak	Horizontal
*	8516.5	34.2	14.6	48.8	68.2	-19.4	Peak	Horizontal
	9471.5	35.7	15.4	51.1	74.0	-22.9	Peak	Horizontal
	11803.5	32.9	19.3	52.2	74.0	-21.8	Peak	Horizontal
*	7210.7	34.6	13.7	48.3	68.2	-19.9	Peak	Vertical
*	7865.5	34.2	15.0	49.2	68.2	-19.0	Peak	Vertical
	9437.6	35.3	15.5	50.8	74.0	-23.2	Peak	Vertical
	11803.5	33.0	19.3	52.3	74.0	-21.7	Peak	Vertical

Note 1: "*" is not in restricted band, its limit is -27dBm/MHz. At a distance of 3 meters, the field strength limit in dB μ V/m can be determined by adding a "conversion" factor of 95.2dB to the EIRP limit of -27dBm/MHz to obtain the limit for out of band spurious emissions of 68.2dB μ V/m.

Note 2: Measure Level (dB μ V/m) = Reading Level (dB μ V) + Factor (dB)

Factor (dB) = Cable Loss (dB) + Antenna Factor (dB/m) - Pre_Amplifier Gain (dB)

Test Mode:	802.11ac-VHT80	Test Site:	AC1
Test Channel:	42	Test Engineer:	Roy Cheng
Remark:	1. Average measurement was not performed if peak level lower than average limit. 2. Other frequency was 20dB below limit line within 1-18GHz, there is not show in the report.		

Mark	Frequency (MHz)	Reading Level (dB μ V)	Factor (dB)	Measure Level (dB μ V/m)	Limit (dB μ V/m)	Margin (dB)	Detector	Polarization
*	7263.5	34.7	13.9	48.6	68.2	-19.6	Peak	Horizontal
*	8515.5	34.5	14.6	49.1	68.2	-19.1	Peak	Horizontal
	9376.6	35.3	15.3	50.6	74.0	-23.4	Peak	Horizontal
	11854.5	33.4	19.5	52.9	74.0	-21.1	Peak	Horizontal
*	7163.5	34.5	13.6	48.1	68.2	-20.1	Peak	Vertical
*	8547.5	33.9	14.5	48.4	68.2	-19.8	Peak	Vertical
	9392.5	34.9	15.4	50.3	74.0	-23.7	Peak	Vertical
	11259.5	33.6	18.8	52.4	74.0	-21.6	Peak	Vertical

Note 1: "*" is not in restricted band, its limit is -27dBm/MHz. At a distance of 3 meters, the field strength limit in dB μ V/m can be determined by adding a "conversion" factor of 95.2dB to the EIRP limit of -27dBm/MHz to obtain the limit for out of band spurious emissions of 68.2dB μ V/m.

Note 2: Measure Level (dB μ V/m) = Reading Level (dB μ V) + Factor (dB)

Factor (dB) = Cable Loss (dB) + Antenna Factor (dB/m) - Pre_Amplifier Gain (dB)

Test Mode:	802.11ac-VHT80	Test Site:	AC1
Test Channel:	58	Test Engineer:	Roy Cheng
Remark:	1. Average measurement was not performed if peak level lower than average limit. 2. Other frequency was 20dB below limit line within 1-18GHz, there is not show in the report.		

Mark	Frequency (MHz)	Reading Level (dB μ V)	Factor (dB)	Measure Level (dB μ V/m)	Limit (dB μ V/m)	Margin (dB)	Detector	Polarization
*	7149.6	33.6	13.5	47.1	68.2	-21.1	Peak	Horizontal
*	8573.5	34.2	14.5	48.7	68.2	-19.5	Peak	Horizontal
	9305.5	34.5	15.4	49.9	74.0	-24.1	Peak	Horizontal
	10681.5	34.0	17.6	51.6	74.0	-22.4	Peak	Horizontal
*	7052.0	38.6	13.1	51.7	68.2	-16.5	Peak	Vertical
*	7869.4	33.6	15.0	48.6	68.2	-19.6	Peak	Vertical
	9168.6	35.2	15.3	50.5	74.0	-23.5	Peak	Vertical
	11803.5	33.2	19.3	52.5	74.0	-21.5	Peak	Vertical

Note 1: "*" is not in restricted band, its limit is -27dBm/MHz. At a distance of 3 meters, the field strength limit in dB μ V/m can be determined by adding a "conversion" factor of 95.2dB to the EIRP limit of -27dBm/MHz to obtain the limit for out of band spurious emissions of 68.2dB μ V/m.

Note 2: Measure Level (dB μ V/m) = Reading Level (dB μ V) + Factor (dB)

Factor (dB) = Cable Loss (dB) + Antenna Factor (dB/m) - Pre_Amplifier Gain (dB)

Test Mode:	802.11ac-VHT80	Test Site:	AC1
Test Channel:	106	Test Engineer:	Roy Cheng
Remark:	1. Average measurement was not performed if peak level lower than average limit. 2. Other frequency was 20dB below limit line within 1-18GHz, there is not show in the report.		

Mark	Frequency (MHz)	Reading Level (dB μ V)	Factor (dB)	Measure Level (dB μ V/m)	Limit (dB μ V/m)	Margin (dB)	Detector	Polarization
*	7053.7	35.1	13.1	48.2	68.2	-20.0	Peak	Horizontal
*	7983.5	34.3	15.0	49.3	68.2	-18.9	Peak	Horizontal
	9483.5	35.2	15.4	50.6	74.0	-23.4	Peak	Horizontal
	11803.5	33.0	19.3	52.3	74.0	-21.7	Peak	Horizontal
*	7159.9	34.5	13.6	48.1	68.2	-20.1	Peak	Vertical
*	8573.6	35.3	14.5	49.8	68.2	-18.4	Peak	Vertical
	9405.5	35.3	15.4	50.7	74.0	-23.3	Peak	Vertical
	12653.5	33.3	19.8	53.1	74.0	-20.9	Peak	Vertical

Note 1: "*" is not in restricted band, its limit is -27dBm/MHz. At a distance of 3 meters, the field strength limit in dB μ V/m can be determined by adding a "conversion" factor of 95.2dB to the EIRP limit of -27dBm/MHz to obtain the limit for out of band spurious emissions of 68.2dB μ V/m.

Note 2: Measure Level (dB μ V/m) = Reading Level (dB μ V) + Factor (dB)

Factor (dB) = Cable Loss (dB) + Antenna Factor (dB/m) - Pre_Amplifier Gain (dB)

Test Mode:	802.11ac-VHT80	Test Site:	AC1
Test Channel:	138	Test Engineer:	Roy Cheng
Remark:	1. Average measurement was not performed if peak level lower than average limit. 2. Other frequency was 20dB below limit line within 1-18GHz, there is not show in the report.		

Mark	Frequency (MHz)	Reading Level (dB μ V)	Factor (dB)	Measure Level (dB μ V/m)	Limit (dB μ V/m)	Margin (dB)	Detector	Polarization
*	7243.7	34.0	13.8	47.8	68.2	-20.4	Peak	Horizontal
*	8006.5	33.9	15.1	49.0	68.2	-19.2	Peak	Horizontal
	9373.6	34.6	15.3	49.9	74.0	-24.1	Peak	Horizontal
	11803.5	33.1	19.3	52.4	74.0	-21.6	Peak	Horizontal
*	7195.5	35.4	13.6	49.0	68.2	-19.2	Peak	Vertical
*	8507.5	34.7	14.6	49.3	68.2	-18.9	Peak	Vertical
	9365.5	36.0	15.3	51.3	74.0	-22.7	Peak	Vertical
	11735.5	34.3	19.2	53.5	74.0	-20.5	Peak	Vertical

Note 1: "*" is not in restricted band, its limit is -27dBm/MHz. At a distance of 3 meters, the field strength limit in dB μ V/m can be determined by adding a "conversion" factor of 95.2dB to the EIRP limit of -27dBm/MHz to obtain the limit for out of band spurious emissions of 68.2dB μ V/m.

Note 2: Measure Level (dB μ V/m) = Reading Level (dB μ V) + Factor (dB)

Factor (dB) = Cable Loss (dB) + Antenna Factor (dB/m) - Pre_Amplifier Gain (dB)

The worst case of Radiated Emission below 1GHz:

Engineer: Sunny Sun	
Site: AC1	Time: 2014/07/27 - 14:11
Limit: FCC_Part15.209_RE(3m)	Margin: 0
Probe: VULB9162_0.03-8GHz	Polarity: Horizontal
EUT: WIFI dual band 4 GE LAN GPON HGU	Power: AC 120V/60Hz
Worst Case Mode: 802.11a Channel 5180MHz	

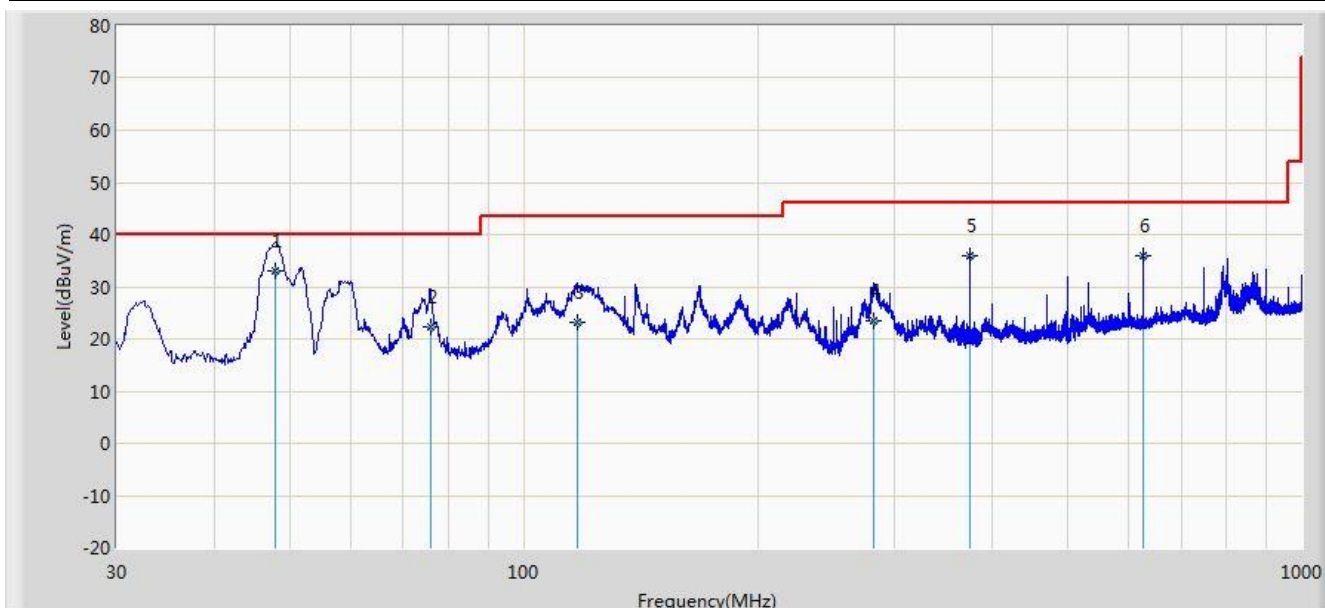

No	Flag	Mark	Frequency (MHz)	Measure Level (dBuV/m)	Reading Level (dBuV)	Over Limit (dB)	Limit (dBuV/m)	Factor (dB)	Type
1			47.945	33.151	18.360	-6.849	40.000	14.792	QP
2			75.833	22.228	12.900	-17.772	40.000	9.328	QP
3			117.201	23.141	11.700	-20.359	43.500	11.441	QP
4			281.959	23.394	9.600	-22.606	46.000	13.794	QP
5		*	374.992	35.832	20.100	-10.168	46.000	15.732	QP
6			625.003	35.922	16.200	-10.078	46.000	19.722	QP

Note: Measure Level (dBuV/m) = Reading Level (dBuV) + Factor (dB)

Factor (dB) = Cable Loss (dB) + Antenna Factor (dB/m)

Engineer: Sunny Sun	
Site: AC1	Time: 2014/07/27 - 13:39
Limit: FCC_Part15.209_RE(3m)	Margin: 0
Probe: VULB9162_0.03-8GHz	Polarity: Vertical
EUT: WIFI dual band 4 GE LAN GPON HGU	Power: AC 120V/60Hz
Worst Case Mode: 802.11a Channel 5180MHz	

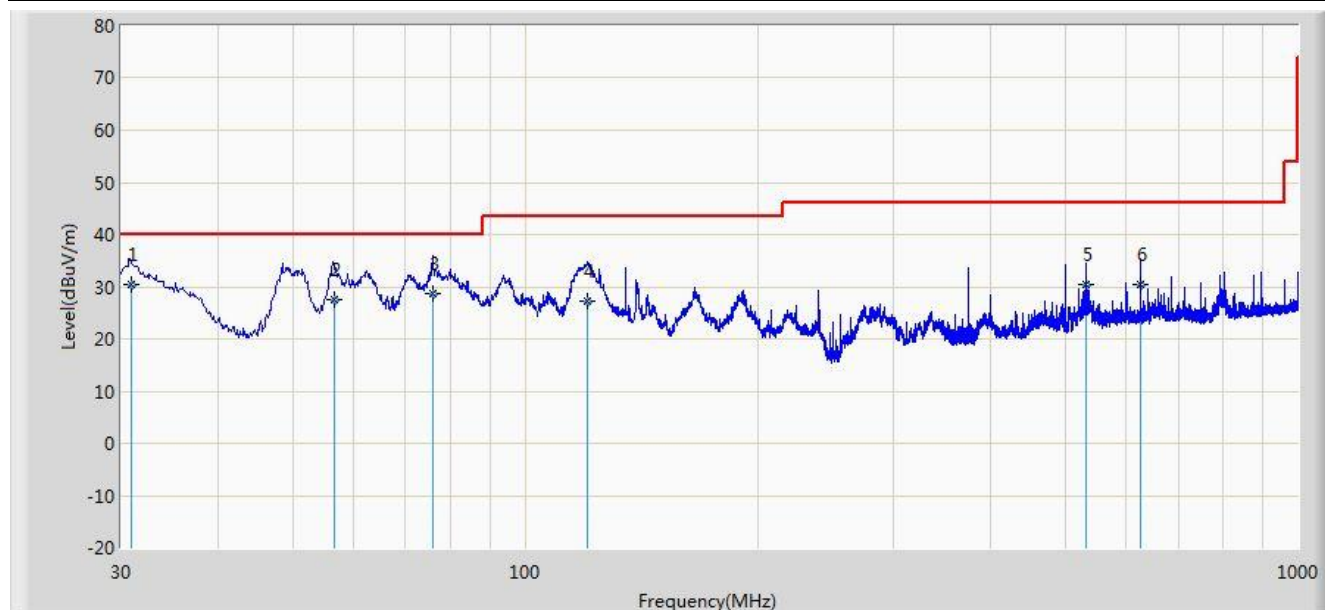

No	Flag	Mark	Frequency (MHz)	Measure Level (dBuV/m)	Reading Level (dBuV)	Over Limit (dB)	Limit (dBuV/m)	Factor (dB)	Type
1		*	30.937	30.372	18.300	-9.628	40.000	12.072	QP
2			56.581	27.646	13.400	-12.354	40.000	14.246	QP
3			75.965	28.796	19.500	-11.204	40.000	9.296	QP
4			120.238	27.373	16.400	-16.127	43.500	10.973	QP
5			531.260	30.387	12.200	-15.613	46.000	18.187	QP
6			624.999	30.522	10.800	-15.478	46.000	19.722	QP

Note: Measure Level (dBuV/m) = Reading Level (dBuV) + Factor (dB)

Factor (dB) = Cable Loss (dB) + Antenna Factor (dB/m)

Engineer: Roy Cheng	
Site: AC1	Time: 2014/07/27 - 13:42
Limit: FCC_Part15.209_RE(3m)	Margin: 0
Probe: FMZB1519_0.009-30MHz	Polarity: Face On
EUT: WIFI dual band 4 GE LAN GPON HGU	Power: AC 120V/60Hz
Note: There is the ambient noise within frequency range 9kHz~30MHz.	

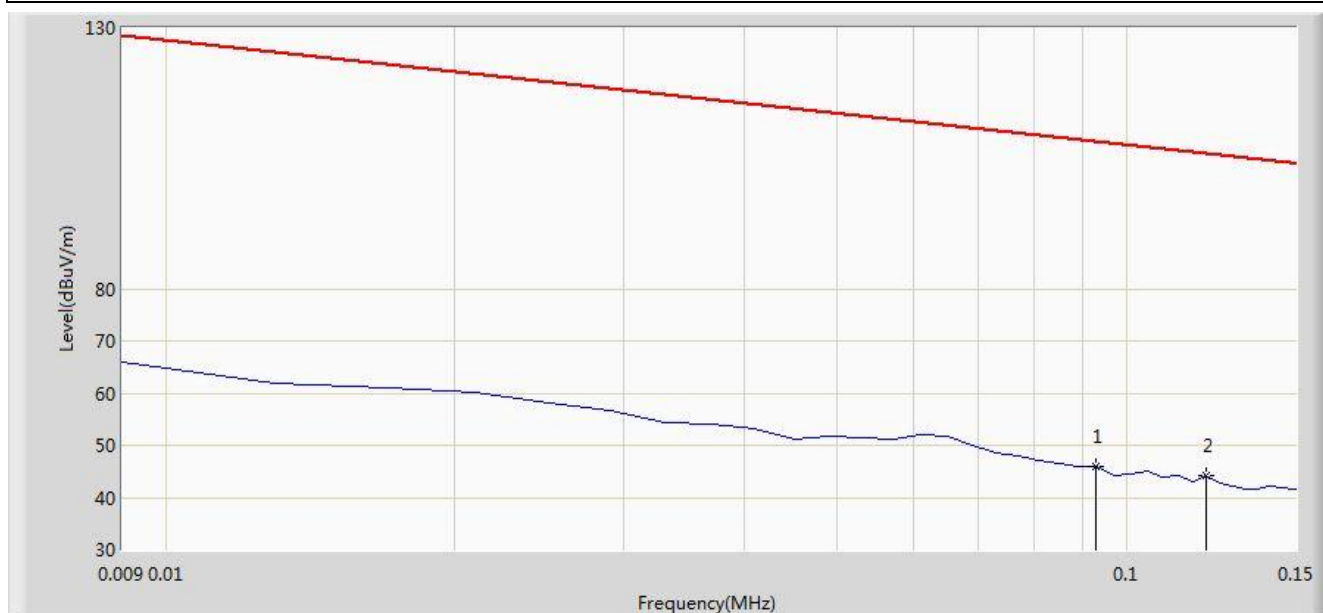

No	Flag	Mark	Frequency (MHz)	Measure Level (dBuV/m)	Reading Level (dBuV)	Over Limit (dB)	Limit (dBuV/m)	Factor (dB)	Type
1			0.093	46.049	25.820	-62.178	108.226	20.229	QP
2		*	0.121	44.063	23.875	-61.879	105.942	20.188	QP

Note: Measure Level (dB μ V/m) = Reading Level (dB μ V) + Factor (dB)

Factor (dB) = Cable Loss (dB) + Antenna Factor (dB/m)

Engineer: Roy Cheng	
Site: AC1	Time: 2014/07/27 - 13:42
Limit: FCC_Part15.209_RE(3m)	Margin: 0
Probe: FMZB1519_0.009-30MHz	Polarity: Face On
EUT: WIFI dual band 4 GE LAN GPON HGU	Power: AC 120V/60Hz
Note: There is the ambient noise within frequency range 9kHz~30MHz.	

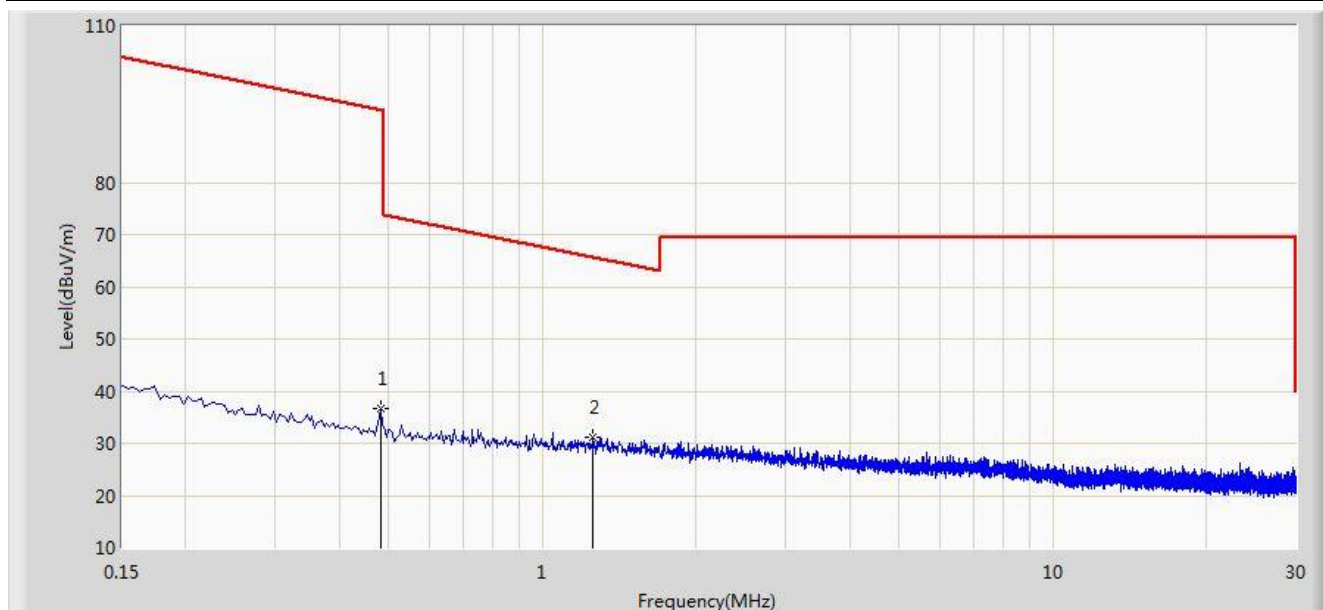

No	Flag	Mark	Frequency (MHz)	Measure Level (dBuV/m)	Reading Level (dBuV)	Over Limit (dB)	Limit (dBuV/m)	Factor (dB)	Type
1			0.482	36.594	16.194	-57.348	93.943	20.401	QP
2		*	1.258	31.288	10.788	-34.345	65.633	20.500	QP

Note: Measure Level (dBμV/m) = Reading Level (dBμV) + Factor (dB)

Factor (dB) = Cable Loss (dB) + Antenna Factor (dB/m)

Engineer: Roy Cheng	
Site: AC1	Time: 2014/07/27 - 12:31
Limit: FCC_Part15.209_RE(1m)	Margin: 0
Probe: BBHA9170_18-40GHz	Polarity: Horizontal
EUT: WIFI dual band 4 GE LAN GPON HGU	Power: AC 120V/60Hz
Note: There is the ambient noise within frequency range 18GHz~40GHz.	



No	Flag	Mark	Frequency (MHz)	Measure Level (dBuV/m)	Reading Level (dBuV)	Over Limit (dB)	Limit (dBuV/m)	Factor (dB)	Type
1			33179.678	48.619	27.098	-14.881	63.500	21.521	AV
2			33180.000	61.501	39.980	-21.999	83.500	21.521	PK
3			38790.000	72.332	44.416	-11.168	83.500	27.916	PK
4			38790.560	59.594	31.678	-3.906	63.500	27.916	AV

Note: Measure Level (dB μ V/m) = Reading Level (dB μ V) + Factor (dB)

Factor (dB) = Cable Loss (dB) + Antenna Factor (dB/m) - Pre_Amplifier Gain (dB)

Engineer: Roy Cheng	
Site: AC1	Time: 2014/07/27 - 12:31
Limit: FCC_Part15.209_RE(1m)	Margin: 0
Probe: BBHA9170_18-40GHz	Polarity: Vertical
EUT: WIFI dual band 4 GE LAN GPON HGU	Power: AC 120V/60Hz
Note: There is the ambient noise within frequency range 18GHz~40GHz.	



No	Flag	Mark	Frequency (MHz)	Measure Level (dBuV/m)	Reading Level (dBuV)	Over Limit (dB)	Limit (dBuV/m)	Factor (dB)	Type
1			33212.889	49.517	27.980	-13.983	63.500	21.537	AV
2			33213.000	62.169	40.632	-21.331	83.500	21.538	PK
3			38118.567	58.968	32.567	-4.532	63.500	26.402	AV
4			38119.000	71.963	45.561	-11.537	83.500	26.403	PK

Note: Measure Level (dB μ V/m) = Reading Level (dB μ V) + Factor (dB)

Factor (dB) = Cable Loss (dB) + Antenna Factor (dB/m) - Pre_Amplifier Gain (dB)

7.9. Radiated Restricted Band Edge Measurement

7.9.1. Test Limit

For 15.205 requirement:

Radiated emissions which fall in the restricted bands, as defined in Section 15.205(a) of FCC part 15, must also comply with the radiated emission limits specified in Section 15.209(a).

MHz	MHz	MHz	GHz
0.090 - 0.110	16.42 - 16.423	399.9 - 410	4.5 - 5.15
¹ 0.495 - 0.505	16.69475 - 16.69525	608 - 614	5.35 - 5.46
2.1735 - 2.1905	16.80425 - 16.80475	960 - 1240	7.25 - 7.75
4.125 - 4.128	25.5 - 25.67	1300 - 1427	8.025 - 8.5
4.17725 - 4.17775	37.5 - 38.25	1435 - 1626.5	9.0 - 9.2
4.20725 - 4.20775	73 - 74.6	1645.5 - 1646.5	9.3 - 9.5
6.215 - 6.218	74.8 - 75.2	1660 - 1710	10.6 - 12.7
6.26775 - 6.26825	108 - 121.94	1718.8 - 1722.2	13.25 - 13.4
6.31175 - 6.31225	123 - 138	2200 - 2300	14.47 - 14.5
8.291 - 8.294	149.9 - 150.05	2310 - 2390	15.35 - 16.2
8.362 - 8.366	156.52475 - 156.52525	2483.5 - 2500	17.7 - 21.4
8.37625 - 8.38675	156.7 - 156.9	2690 - 2900	22.01 - 23.12
8.41425 - 8.41475	162.0125 - 167.17	3260 - 3267	23.6 - 24.0
12.29 - 12.293	167.72 - 173.2	3332 - 3339	31.2 - 31.8
12.51975 - 12.52025	240 - 285	3345.8 - 3358	36.43 - 36.5
12.57675 - 12.57725	322 - 335.4	3600 - 4400	(²)

For 15.407(b) requirement:

For transmitters operating in the 5.15-5.25 GHz band: All emissions outside of the 5.15-5.35 GHz band shall not exceed an e.i.r.p. of -27dBm/MHz.

For transmitters operating in the 5.25-5.35 GHz band: All emissions outside of the 5.15-5.35 GHz band shall not exceed an e.i.r.p. of -27dBm/MHz.

For transmitters operating in the 5.47-5.725 GHz band: All emissions outside of the 5.47-5.725 GHz band shall not exceed an e.i.r.p. of -27dBm/MHz.

For transmitters operating in the 5.725-5.85 GHz band: All emissions within the frequency range from the band edge to 10 MHz above or below the band edge shall not exceed an e.i.r.p. of -17dBm/MHz; for frequencies 10 MHz or greater above or below the band edge, emissions shall not exceed an e.i.r.p. of -27dBm/MHz.

Operating Frequency Band (MHz)	EIRP Limit (dBm/MHz)	Equivalent Field Strength at 3m (dBuV/m)
5150 - 5350	-27	68.2
5470 - 5725	-27	68.2
5725 - 5850	-17	78.2
	-27	68.2

Note: Refer to KDB 789033 D01v01r04 G)2)c), as specified in § 15.407(b), emissions above 1000 MHz that are outside of the restricted bands are subject to a maximum emission limit of -27 dBm/MHz (or -17 dBm/MHz as specified in § 15.407(b)(4)). However, an out-of-band emission that complies with both the peak and average limits of § 15.209 is not required to satisfy the -27 dBm/MHz or -17 dBm/MHz maximum emission limit.

All out of band emissions appearing in a restricted band as specified in Section 15.205 of the Title 47 CFR must not exceed the limits shown in Table per Section 15.209.

FCC Part 15 Subpart C Paragraph 15.209		
Frequency [MHz]	Field Strength [V/m]	Measured Distance [Meters]
0.009 – 0.490	2400/F (kHz)	300
0.490 – 1.705	24000/F (kHz)	30
1.705 - 30	30	30
30 - 88	100	3
88 - 216	150	3
216 - 960	200	3
Above 960	500	3

7.9.2. Test Result of Radiated Restricted Band Edge

Engineer: Roy Cheng	
Site: AC1	Time: 2014/07/15 - 19:25
Limit: FCC_Part15.209_RE(3m)	Margin: 0
Probe: BBHA9120D_1-18GHz	Polarity: Horizontal
EUT: WIFI dual band 4 GE LAN GPON HGU	Power: AC 120V/60Hz
Note: Mode 1: Transmit by 802.11a at channel 5180MHz Ant 0+1+2+3	

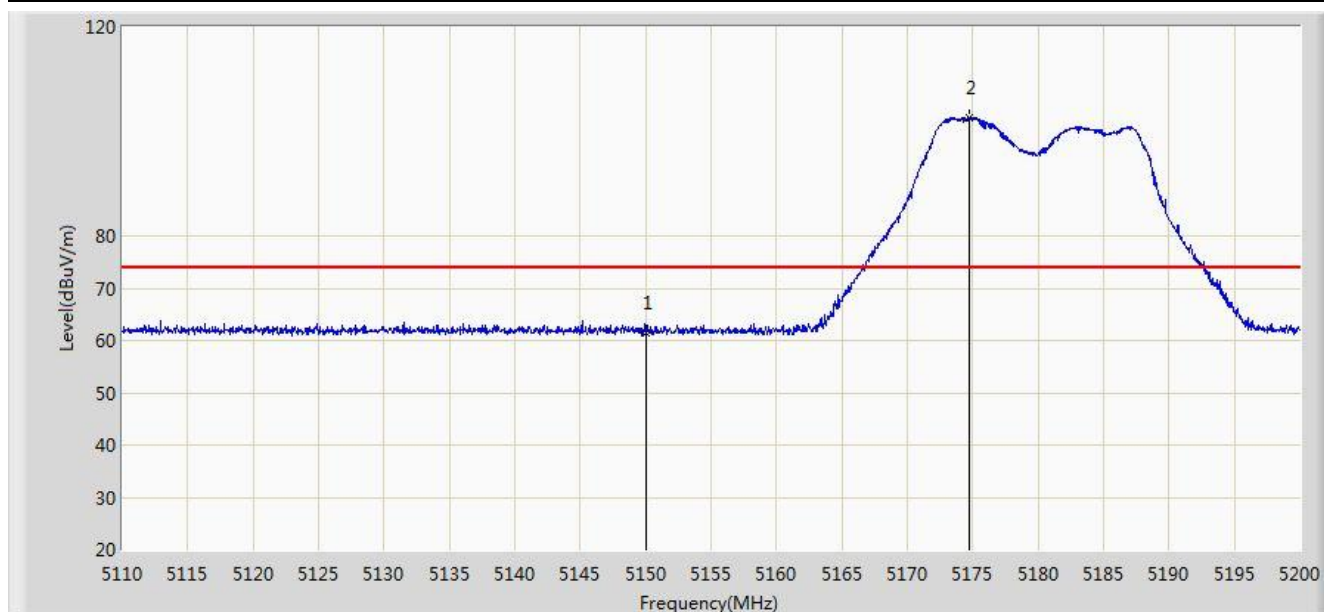

No	Flag	Mark	Frequency (MHz)	Measure Level (dBuV/m)	Reading Level (dBuV)	Over Limit (dB)	Limit (dBuV/m)	Factor (dB)	Type
1			5150.000	61.490	24.738	-12.510	74.000	36.752	PK
2		*	5174.755	102.612	65.930	N/A	N/A	36.682	PK

Note: Measure Level (dB μ V/m) = Reading Level (dB μ V) + Factor (dB)

Factor (dB) = Cable Loss (dB) + Antenna Factor (dB/m).

Engineer: Roy Cheng	
Site: AC1	Time: 2014/07/15 - 19:30
Limit: FCC_Part15.209_RE(3m)	Margin: 0
Probe: BBHA9120D_1-18GHz	Polarity: Horizontal
EUT: WIFI dual band 4 GE LAN GPON HGU	Power: AC 120V/60Hz
Note: Mode 1: Transmit by 802.11a at channel 5180MHz Ant 0+1+2+3	

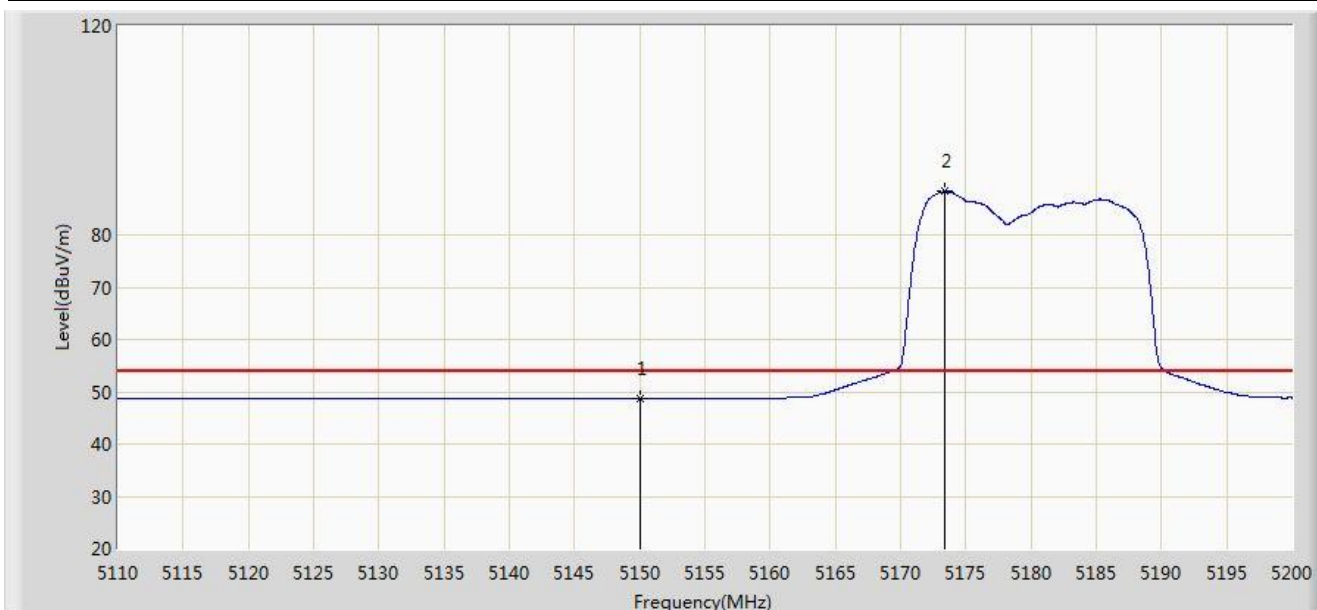

No	Flag	Mark	Frequency (MHz)	Measure Level (dBuV/m)	Reading Level (dBuV)	Over Limit (dB)	Limit (dBuV/m)	Factor (dB)	Type
1			5150.000	48.779	12.027	-5.221	54.000	36.752	AV
2		*	5173.360	88.318	51.632	N/A	N/A	36.686	AV

Note: Measure Level (dB μ V/m) = Reading Level (dB μ V) + Factor (dB)

Factor (dB) = Cable Loss (dB) + Antenna Factor (dB/m).

Engineer: Roy Cheng	
Site: AC1	Time: 2014/07/15 - 19:32
Limit: FCC_Part15.209_RE(3m)	Margin: 0
Probe: BBHA9120D_1-18GHz	Polarity: Vertical
EUT: WIFI dual band 4 GE LAN GPON HGU	Power: AC 120V/60Hz
Note: Mode 1: Transmit by 802.11a at channel 5180MHz Ant 0+1+2+3	

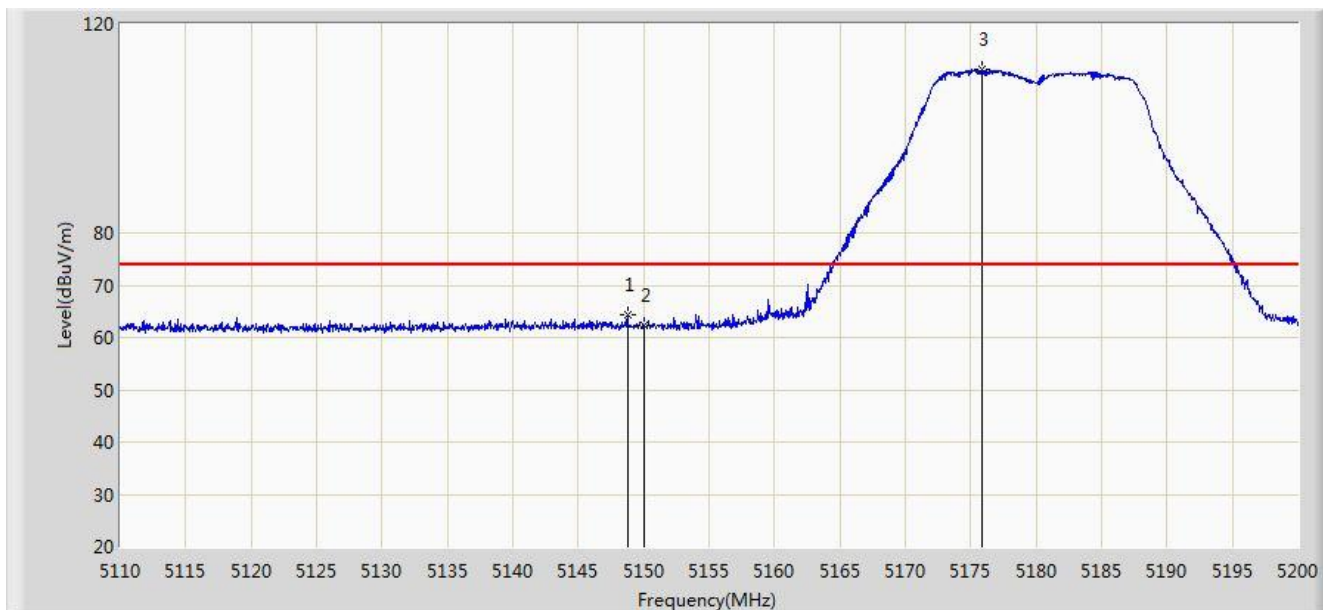

No	Flag	Mark	Frequency (MHz)	Measure Level (dBuV/m)	Reading Level (dBuV)	Over Limit (dB)	Limit (dBuV/m)	Factor (dB)	Type
1			5148.745	64.212	27.458	-9.788	74.000	36.754	PK
2			5150.000	62.384	25.632	-11.616	74.000	36.752	PK
3		*	5175.835	111.195	74.516	N/A	N/A	36.678	PK

Note: Measure Level (dBuV/m) = Reading Level (dBuV) + Factor (dB)

Factor (dB) = Cable Loss (dB) + Antenna Factor (dB/m).

Engineer: Roy Cheng	
Site: AC1	Time: 2014/07/15 - 19:36
Limit: FCC_Part15.209_RE(3m)	Margin: 0
Probe: BBHA9120D_1-18GHz	Polarity: Vertical
EUT: WIFI dual band 4 GE LAN GPON HGU	Power: AC 120V/60Hz
Note: Mode 1: Transmit by 802.11a at channel 5180MHz Ant 0+1+2+3	

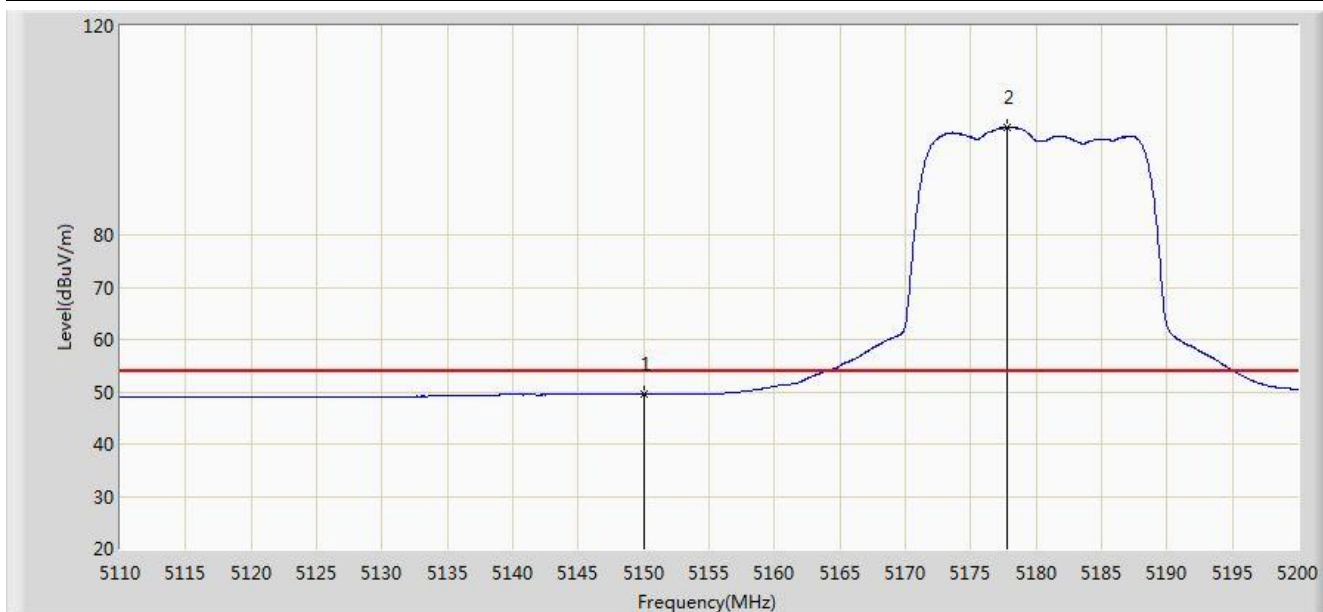

No	Flag	Mark	Frequency (MHz)	Measure Level (dBuV/m)	Reading Level (dBuV)	Over Limit (dB)	Limit (dBuV/m)	Factor (dB)	Type
1			5150.000	49.480	12.728	-4.520	54.000	36.752	AV
2		*	5177.815	100.604	63.932	N/A	N/A	36.673	AV

Note: Measure Level (dB μ V/m) = Reading Level (dB μ V) + Factor (dB)

Factor (dB) = Cable Loss (dB) + Antenna Factor (dB/m).

Engineer: Roy Cheng	
Site: AC1	Time: 2014/07/15 - 19:39
Limit: FCC_Part15.209_RE(3m)	Margin: 0
Probe: BBHA9120D_1-18GHz	Polarity: Horizontal
EUT: WIFI dual band 4 GE LAN GPON HGU	Power: AC 120V/60Hz
Note: Mode 1: Transmit by 802.11a at channel 5320MHz Ant 0+1+2+3	

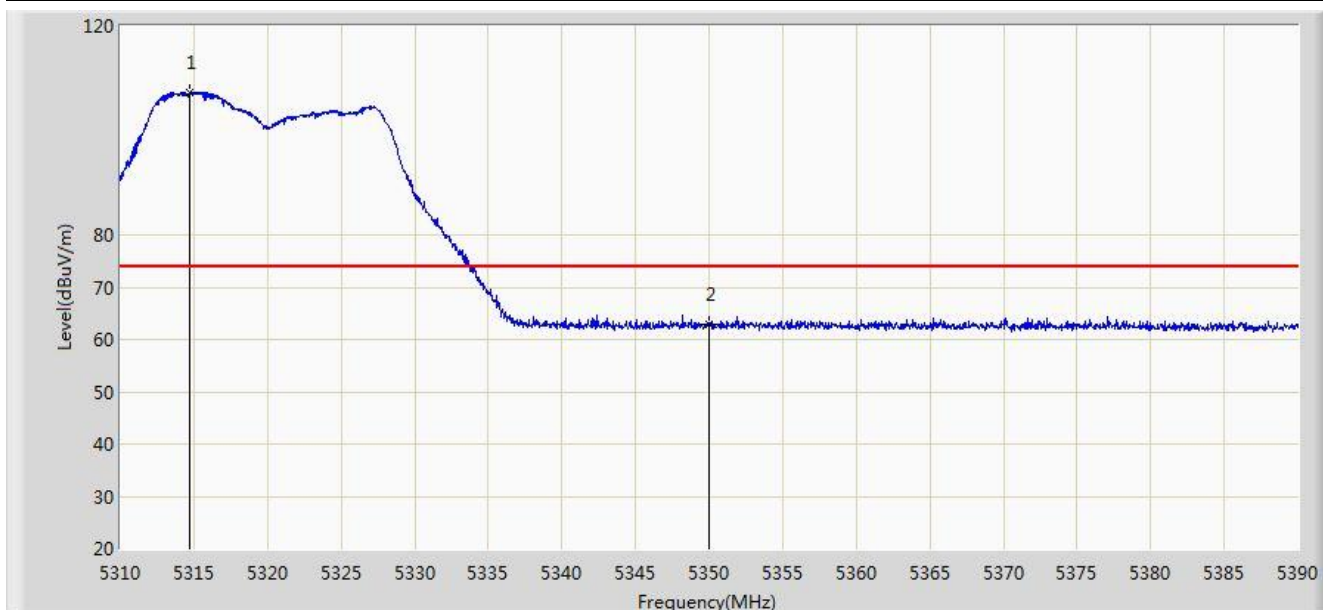

No	Flag	Mark	Frequency (MHz)	Measure Level (dBuV/m)	Reading Level (dBuV)	Over Limit (dB)	Limit (dBuV/m)	Factor (dB)	Type
1		*	5314.720	107.229	70.770	N/A	N/A	36.459	PK
2			5350.000	62.807	26.271	-11.193	74.000	36.536	PK

Note: Measure Level (dB μ V/m) = Reading Level (dB μ V) + Factor (dB)

Factor (dB) = Cable Loss (dB) + Antenna Factor (dB/m).

Engineer: Roy Cheng	
Site: AC1	Time: 2014/07/15 - 19:42
Limit: FCC_Part15.209_RE(3m)	Margin: 0
Probe: BBHA9120D_1-18GHz	Polarity: Horizontal
EUT: WIFI dual band 4 GE LAN GPON HGU	Power: AC 120V/60Hz
Note: Mode 1: Transmit by 802.11a at channel 5320MHz Ant 0+1+2+3	

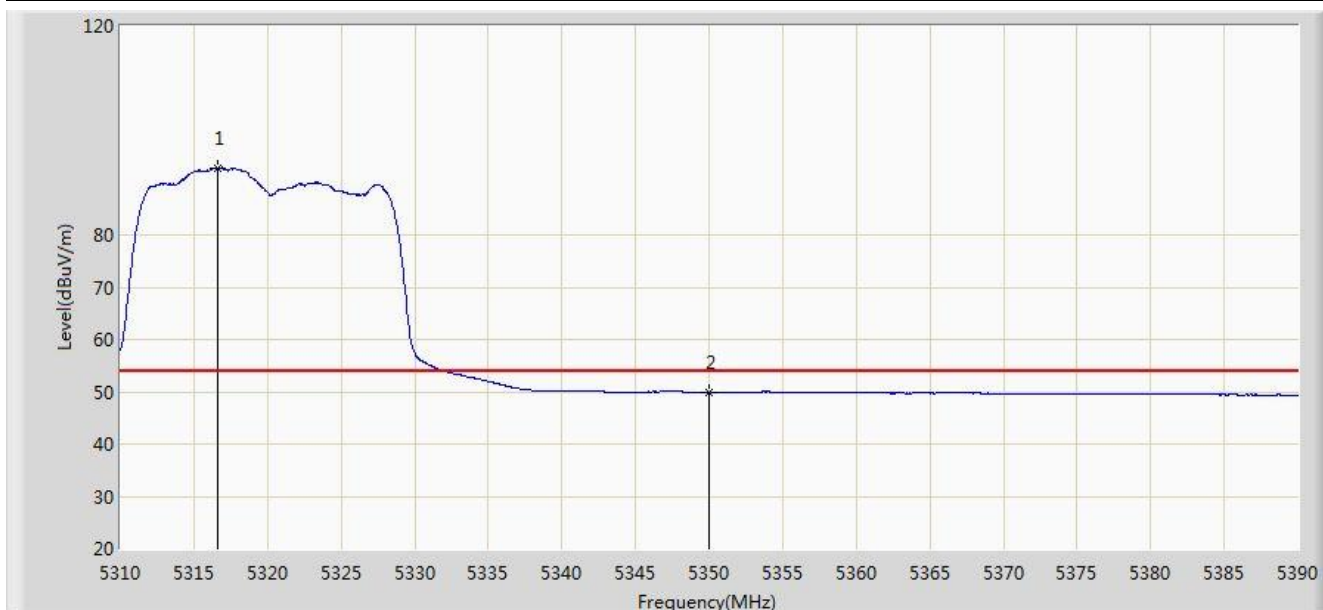

No	Flag	Mark	Frequency (MHz)	Measure Level (dBuV/m)	Reading Level (dBuV)	Over Limit (dB)	Limit (dBuV/m)	Factor (dB)	Type
1		*	5316.600	92.862	56.398	N/A	N/A	36.464	AV
2			5350.000	49.906	13.370	-4.094	54.000	36.536	AV

Note: Measure Level (dB μ V/m) = Reading Level (dB μ V) + Factor (dB)

Factor (dB) = Cable Loss (dB) + Antenna Factor (dB/m).

Engineer: Roy Cheng	
Site: AC1	Time: 2014/07/15 - 19:44
Limit: FCC_Part15.209_RE(3m)	Margin: 0
Probe: BBHA9120D_1-18GHz	Polarity: Vertical
EUT: WIFI dual band 4 GE LAN GPON HGU	Power: AC 120V/60Hz
Note: Mode 1: Transmit by 802.11a at channel 5320MHz Ant 0+1+2+3	

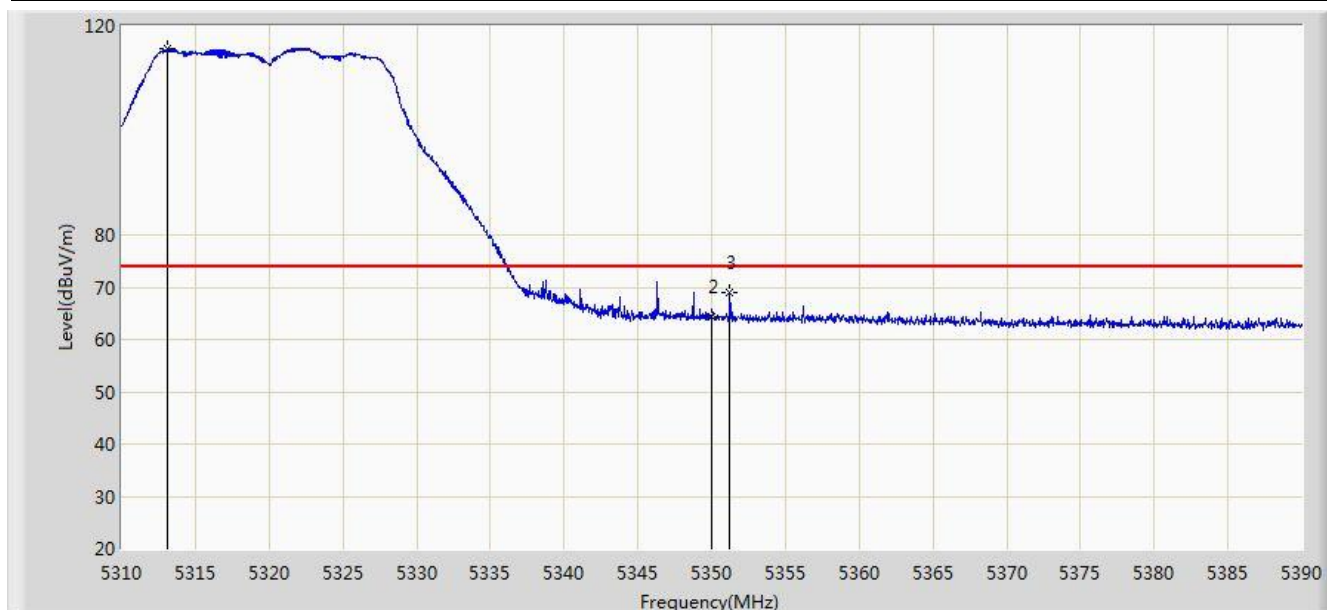

No	Flag	Mark	Frequency (MHz)	Measure Level (dBuV/m)	Reading Level (dBuV)	Over Limit (dB)	Limit (dBuV/m)	Factor (dB)	Type
1		*	5313.120	115.575	79.119	N/A	N/A	36.456	PK
2			5350.000	64.432	27.896	-9.568	74.000	36.536	PK
3			5351.240	68.933	32.394	-5.067	74.000	36.539	PK

Note: Measure Level (dBuV/m) = Reading Level (dBuV) + Factor (dB)

Factor (dB) = Cable Loss (dB) + Antenna Factor (dB/m).

Engineer: Roy Cheng	
Site: AC1	Time: 2014/07/15 - 19:45
Limit: FCC_Part15.209_RE(3m)	Margin: 0
Probe: BBHA9120D_1-18GHz	Polarity: Vertical
EUT: WIFI dual band 4 GE LAN GPON HGU	Power: AC 120V/60Hz
Note: Mode 1: Transmit by 802.11a at channel 5320MHz Ant 0+1+2+3	

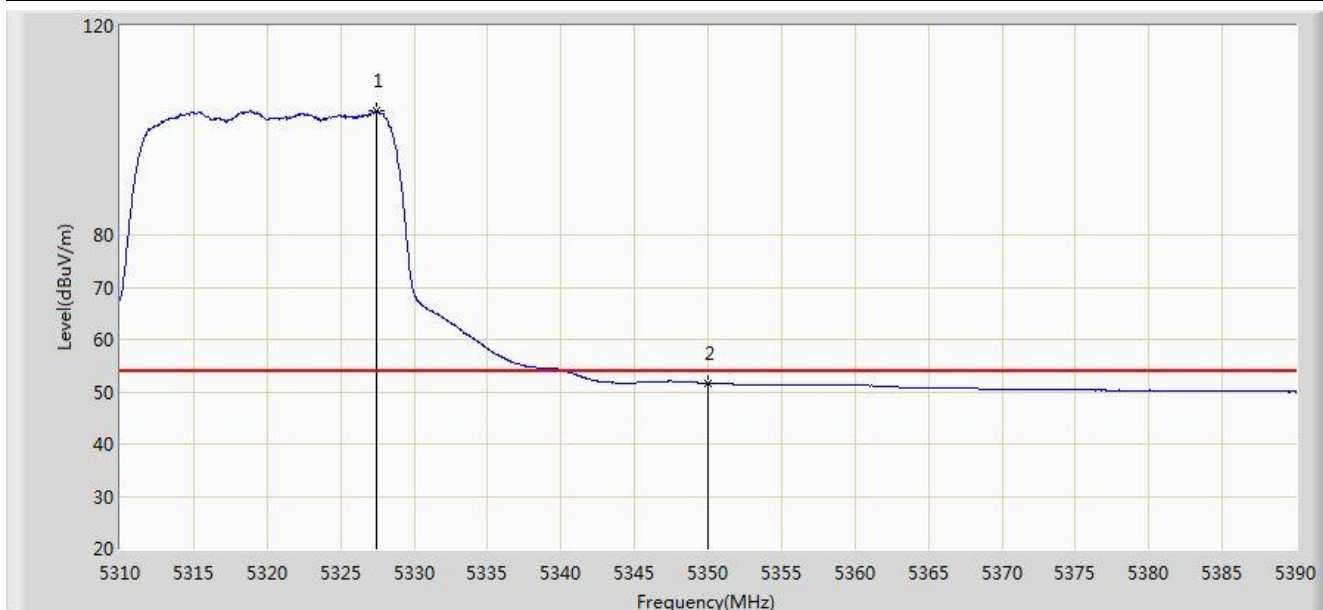

No	Flag	Mark	Frequency (MHz)	Measure Level (dBuV/m)	Reading Level (dBuV)	Over Limit (dB)	Limit (dBuV/m)	Factor (dB)	Type
1		*	5327.400	103.784	67.296	N/A	N/A	36.488	AV
2			5350.000	51.674	15.138	-2.326	54.000	36.536	AV

Note: Measure Level (dB μ V/m) = Reading Level (dB μ V) + Factor (dB)

Factor (dB) = Cable Loss (dB) + Antenna Factor (dB/m).

Engineer: Roy Cheng	
Site: AC1	Time: 2014/07/15 - 19:47
Limit: FCC_Part15.209_RE(3m)	Margin: 0
Probe: BBHA9120D_1-18GHz	Polarity: Horizontal
EUT: WIFI dual band 4 GE LAN GPON HGU	Power: AC 120V/60Hz
Note: Mode 1: Transmit by 802.11a at channel 5500MHz Ant 0+1+2+3	

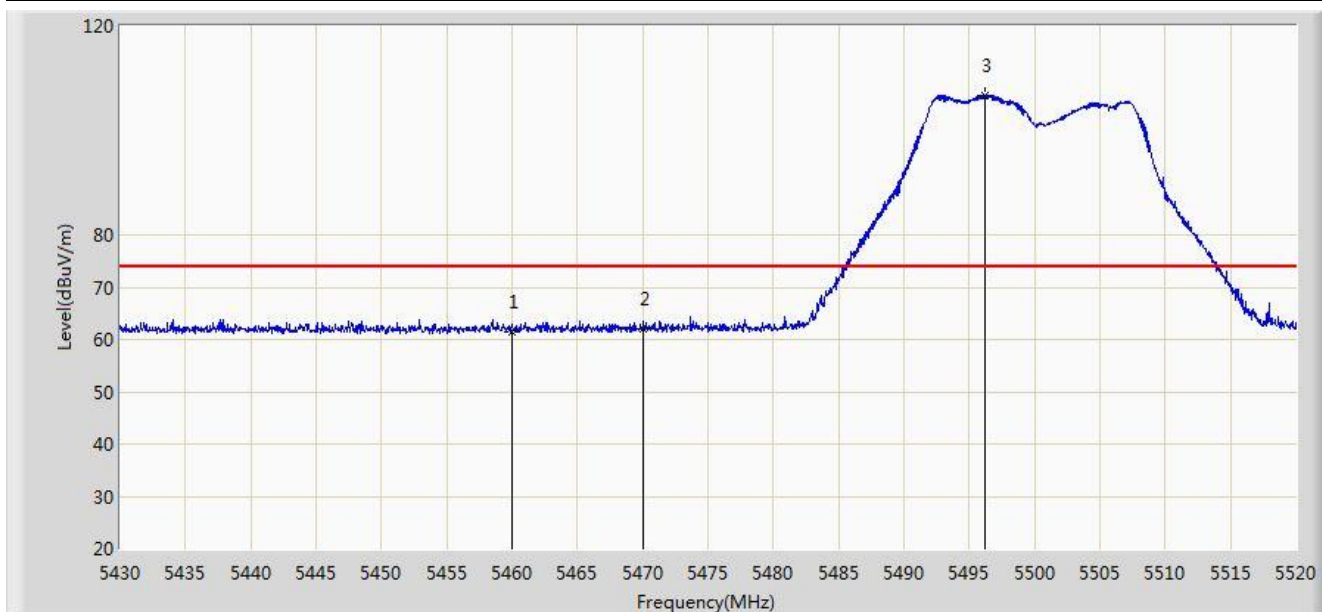

No	Flag	Mark	Frequency (MHz)	Measure Level (dBuV/m)	Reading Level (dBuV)	Over Limit (dB)	Limit (dBuV/m)	Factor (dB)	Type
1			5460.000	61.584	24.774	-12.416	74.000	36.810	PK
2			5470.000	61.947	25.122	-12.053	74.000	36.825	PK
3		*	5496.150	106.802	69.935	N/A	N/A	36.868	PK

Note: Measure Level (dBuV/m) = Reading Level (dBuV) + Factor (dB)

Factor (dB) = Cable Loss (dB) + Antenna Factor (dB/m).

Engineer: Roy Cheng	
Site: AC1	Time: 2014/07/15 - 19:49
Limit: FCC_Part15.209_RE(3m)	Margin: 0
Probe: BBHA9120D_1-18GHz	Polarity: Horizontal
EUT: WIFI dual band 4 GE LAN GPON HGU	Power: AC 120V/60Hz
Note: Mode 1: Transmit by 802.11a at channel 5500MHz Ant 0+1+2+3	

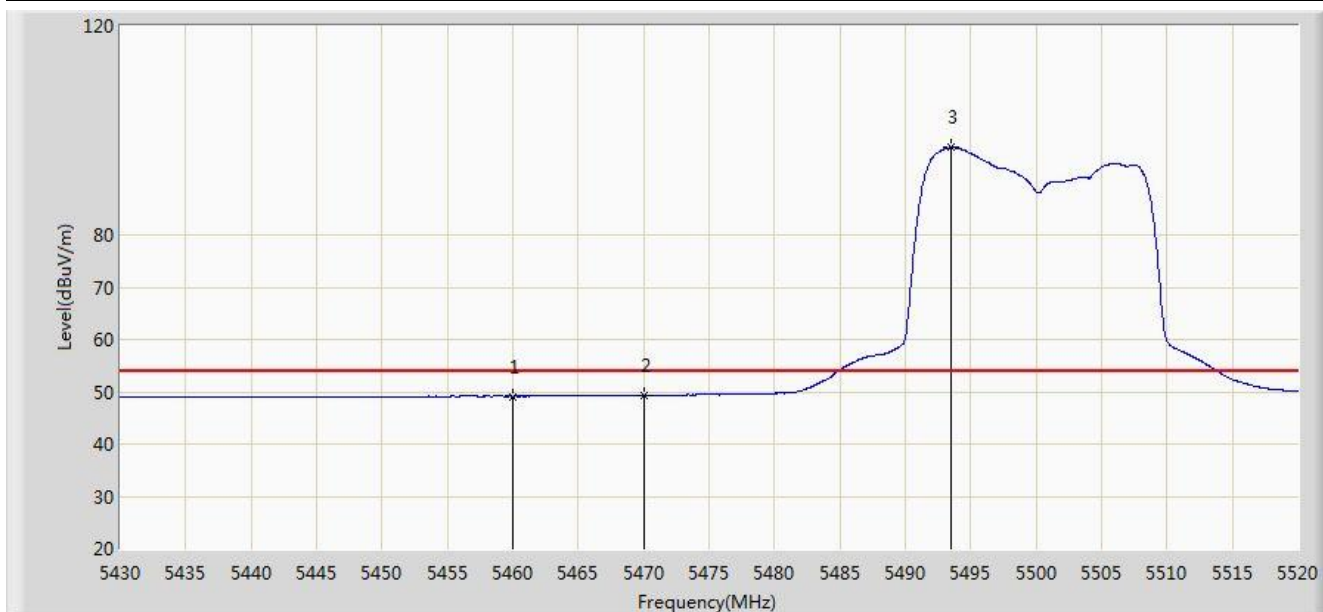

No	Flag	Mark	Frequency (MHz)	Measure Level (dBuV/m)	Reading Level (dBuV)	Over Limit (dB)	Limit (dBuV/m)	Factor (dB)	Type
1			5460.000	49.101	12.291	-4.899	54.000	36.810	AV
2			5470.000	49.331	12.506	-4.669	54.000	36.825	AV
3		*	5493.495	96.756	59.893	N/A	N/A	36.863	AV

Note: Measure Level (dB μ V/m) = Reading Level (dB μ V) + Factor (dB)

Factor (dB) = Cable Loss (dB) + Antenna Factor (dB/m).

Engineer: Roy Cheng	
Site: AC1	Time: 2014/07/15 - 19:52
Limit: FCC_Part15.209_RE(3m)	Margin: 0
Probe: BBHA9120D_1-18GHz	Polarity: Vertical
EUT: WIFI dual band 4 GE LAN GPON HGU	Power: AC 120V/60Hz
Note: Mode 1: Transmit by 802.11a at channel 5500MHz Ant 0+1+2+3	

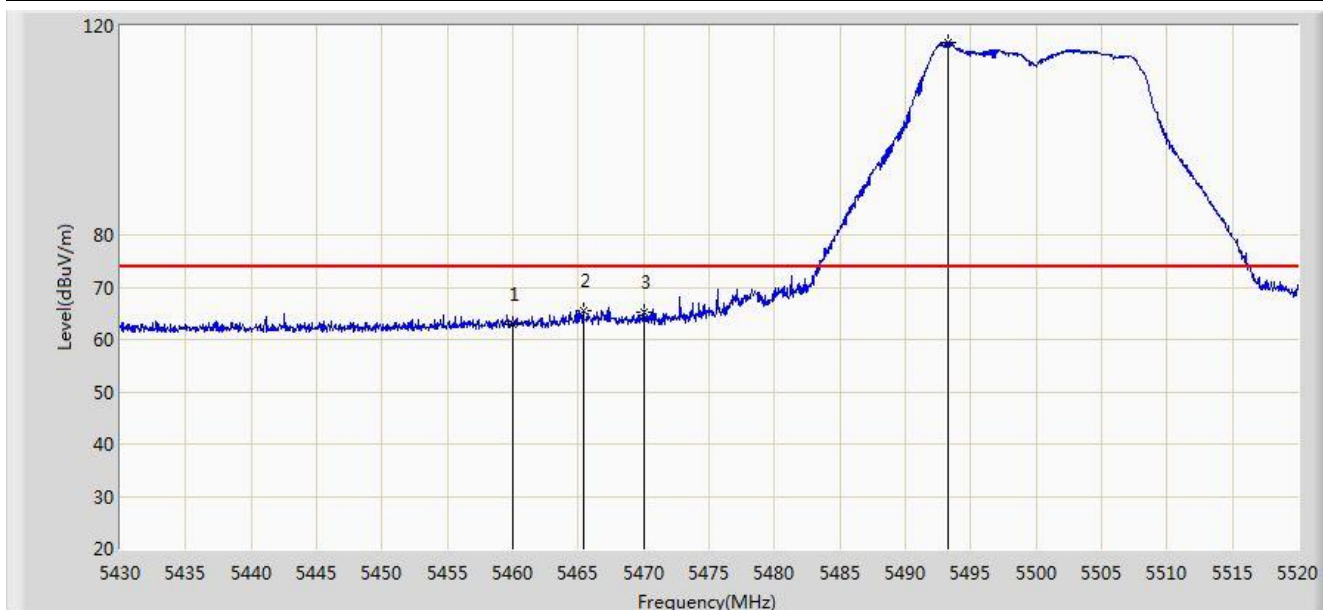

No	Flag	Mark	Frequency (MHz)	Measure Level (dBuV/m)	Reading Level (dBuV)	Over Limit (dB)	Limit (dBuV/m)	Factor (dB)	Type
1			5460.000	63.037	26.227	-10.963	74.000	36.810	PK
2			5465.370	65.642	28.824	-8.358	74.000	36.817	PK
3			5470.000	65.337	28.512	-8.663	74.000	36.825	PK
4		*	5493.225	116.741	79.879	N/A	N/A	36.862	PK

Note: Measure Level (dBuV/m) = Reading Level (dBuV) + Factor (dB)

Factor (dB) = Cable Loss (dB) + Antenna Factor (dB/m).

Engineer: Roy Cheng	
Site: AC1	Time: 2014/07/15 - 19:53
Limit: FCC_Part15.209_RE(3m)	Margin: 0
Probe: BBHA9120D_1-18GHz	Polarity: Vertical
EUT: WIFI dual band 4 GE LAN GPON HGU	Power: AC 120V/60Hz
Note: Mode 1: Transmit by 802.11a at channel 5500MHz Ant 0+1+2+3	

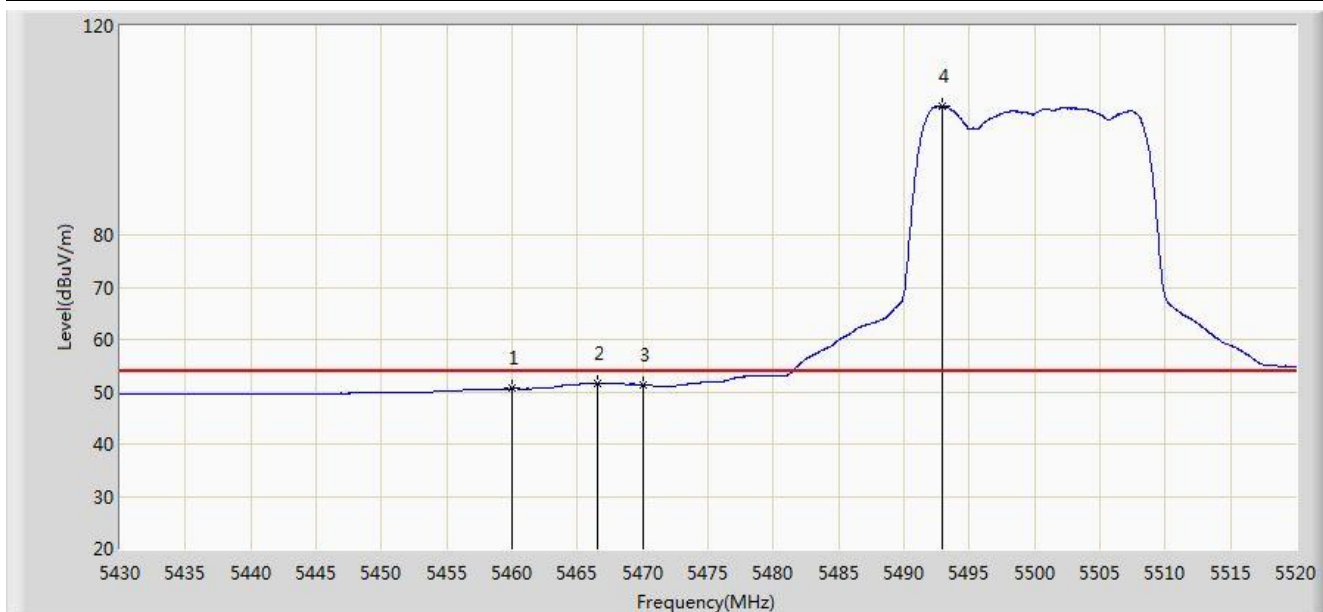

No	Flag	Mark	Frequency (MHz)	Measure Level (dBuV/m)	Reading Level (dBuV)	Over Limit (dB)	Limit (dBuV/m)	Factor (dB)	Type
1			5460.000	50.636	13.826	-3.364	54.000	36.810	AV
2			5466.495	51.563	14.744	-2.437	54.000	36.820	AV
3			5470.000	51.411	14.586	-2.589	54.000	36.825	AV
4		*	5492.955	104.567	67.705	N/A	N/A	36.861	AV

Note: Measure Level (dB μ V/m) = Reading Level (dB μ V) + Factor (dB)

Factor (dB) = Cable Loss (dB) + Antenna Factor (dB/m).

Engineer: Roy Cheng	
Site: AC1	Time: 2014/07/15 - 19:55
Limit: FCC_Part15.209_RE(3m)	Margin: 0
Probe: BBHA9120D_1-18GHz	Polarity: Horizontal
EUT: WIFI dual band 4 GE LAN GPON HGU	Power: AC 120V/60Hz
Note: Mode 1: Transmit by 802.11a at channel 5700MHz Ant 0+1+2+3	

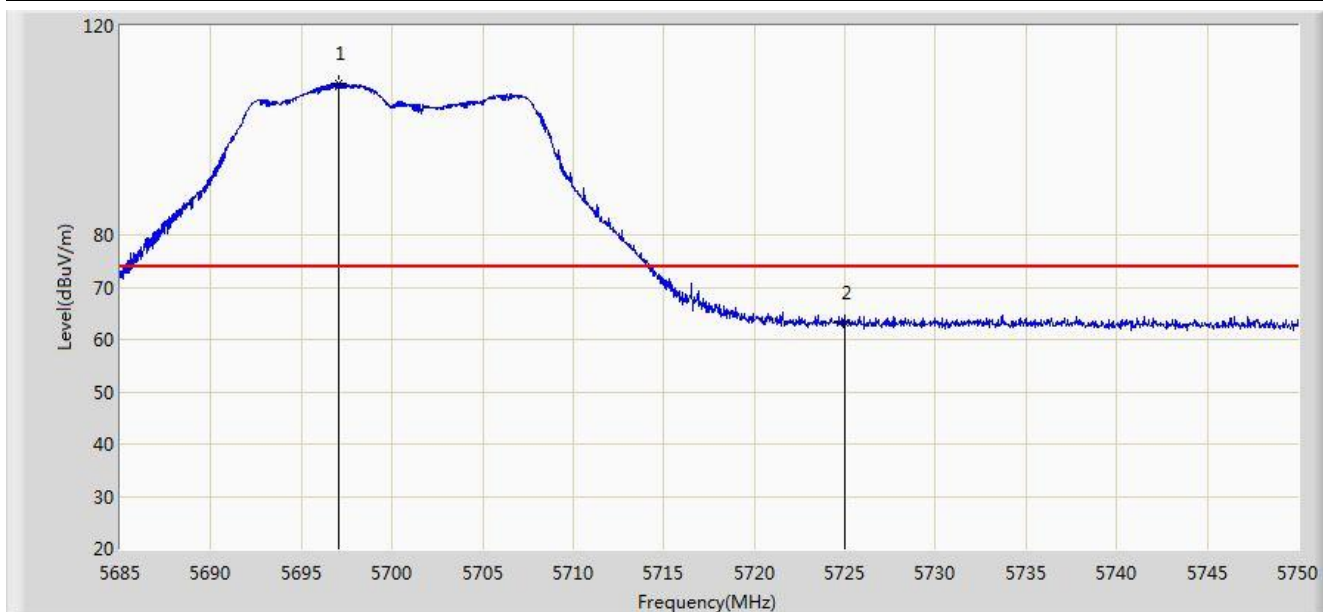

No	Flag	Mark	Frequency (MHz)	Measure Level (dBuV/m)	Reading Level (dBuV)	Over Limit (dB)	Limit (dBuV/m)	Factor (dB)	Type
1		*	5697.090	108.876	71.684	N/A	N/A	37.192	PK
2			5725.000	63.162	25.857	-10.838	74.000	37.305	PK

Note: Measure Level (dB μ V/m) = Reading Level (dB μ V) + Factor (dB)

Factor (dB) = Cable Loss (dB) + Antenna Factor (dB/m).

Engineer: Roy Cheng	
Site: AC1	Time: 2014/07/15 - 20:00
Limit: FCC_Part15.209_RE(3m)	Margin: 0
Probe: BBHA9120D_1-18GHz	Polarity: Horizontal
EUT: WIFI dual band 4 GE LAN GPON HGU	Power: AC 120V/60Hz
Note: Mode 1: Transmit by 802.11a at channel 5700MHz Ant 0+1+2+3	

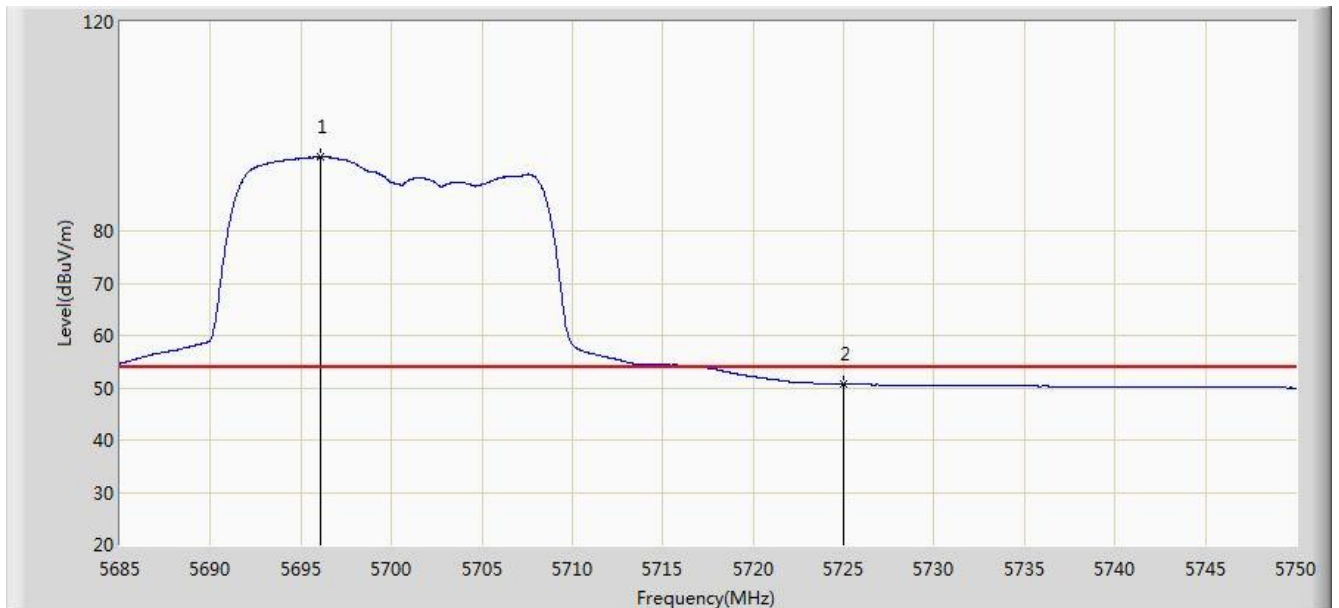

No	Flag	Mark	Frequency (MHz)	Measure Level (dBuV/m)	Reading Level (dBuV)	Over Limit (dB)	Limit (dBuV/m)	Factor (dB)	Type
1		*	5696.083	94.132	56.943	N/A	N/A	37.189	AV
2			5725.000	50.690	13.385	-3.310	54.000	37.305	AV

Note: Measure Level (dB μ V/m) = Reading Level (dB μ V) + Factor (dB)

Factor (dB) = Cable Loss (dB) + Antenna Factor (dB/m).

Engineer: Roy Cheng	
Site: AC1	Time: 2014/07/15 - 20:06
Limit: FCC_Part15.209_RE(3m)	Margin: 0
Probe: BBHA9120D_1-18GHz	Polarity: Vertical
EUT: WIFI dual band 4 GE LAN GPON HGU	Power: AC 120V/60Hz
Note: Mode 1: Transmit by 802.11a at channel 5700MHz Ant 0+1+2+3 Power=13	

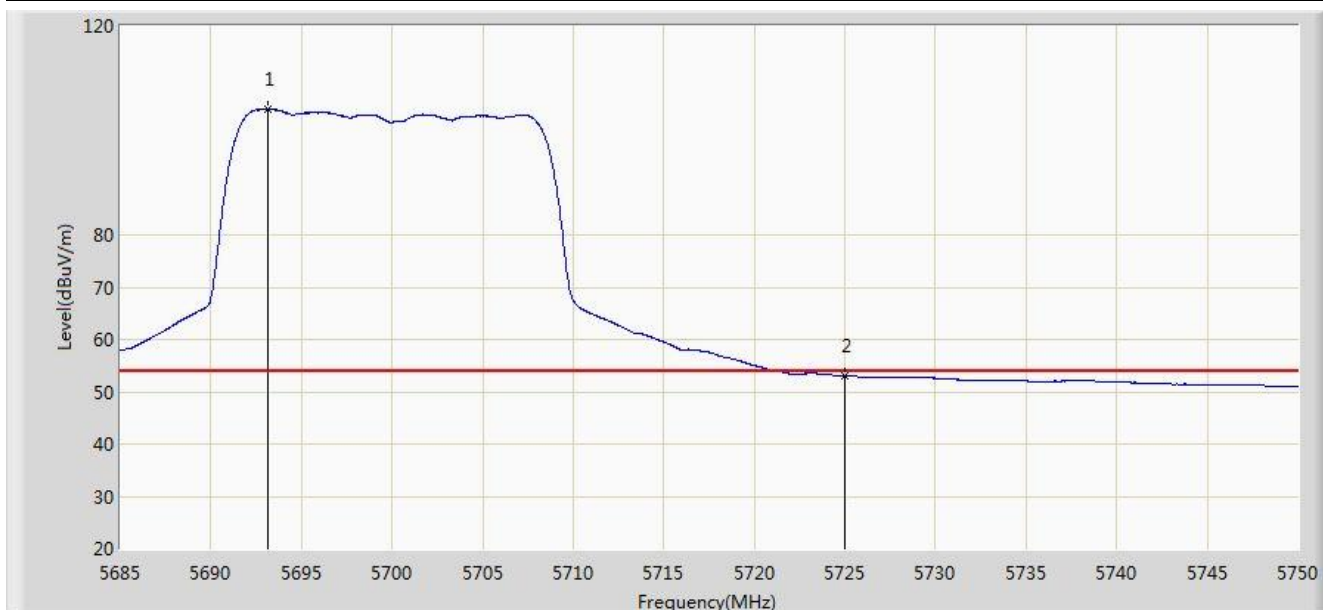

No	Flag	Mark	Frequency (MHz)	Measure Level (dBuV/m)	Reading Level (dBuV)	Over Limit (dB)	Limit (dBuV/m)	Factor (dB)	Type
1		*	5693.158	104.085	66.907	N/A	N/A	37.179	AV
2			5725.000	53.024	15.719	-0.976	54.000	37.305	AV

Note: Measure Level (dB μ V/m) = Reading Level (dB μ V) + Factor (dB)

Factor (dB) = Cable Loss (dB) + Antenna Factor (dB/m).

Engineer: Roy Cheng	
Site: AC1	Time: 2014/07/15 - 20:14
Limit: FCC_Part15.209_RE(3m)	Margin: 0
Probe: BBHA9120D_1-18GHz	Polarity: Vertical
EUT: WIFI dual band 4 GE LAN GPON HGU	Power: AC 120V/60Hz
Note: Mode 1: Transmit by 802.11a at channel 5700MHz Ant 0+1+2+3 Power=13	

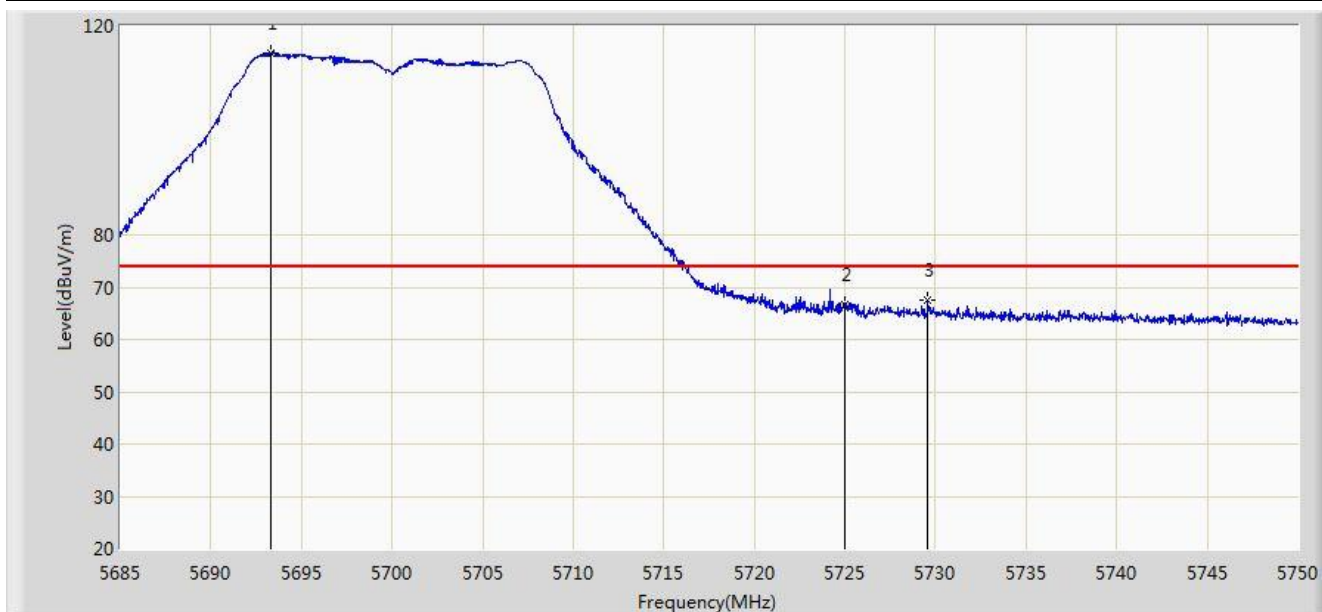

No	Flag	Mark	Frequency (MHz)	Measure Level (dBuV/m)	Reading Level (dBuV)	Over Limit (dB)	Limit (dBuV/m)	Factor (dB)	Type
1		*	5693.320	114.877	77.698	N/A	N/A	37.179	PK
2			5725.000	66.693	29.388	-7.307	74.000	37.305	PK
3			5729.590	67.564	30.241	-6.436	74.000	37.324	PK

Note: Measure Level (dBuV/m) = Reading Level (dBuV) + Factor (dB)

Factor (dB) = Cable Loss (dB) + Antenna Factor (dB/m).

Engineer: Roy Cheng	
Site: AC1	Time: 2014/07/15 - 20:16
Limit: FCC_Part15.209_RE(3m)	Margin: 0
Probe: BBHA9120D_1-18GHz	Polarity: Horizontal
EUT: WIFI dual band 4 GE LAN GPON HGU	Power: AC 120V/60Hz
Note: Mode 2: Transmit by 802.11n20 at channel 5180MHz Ant 0+1+2+3	

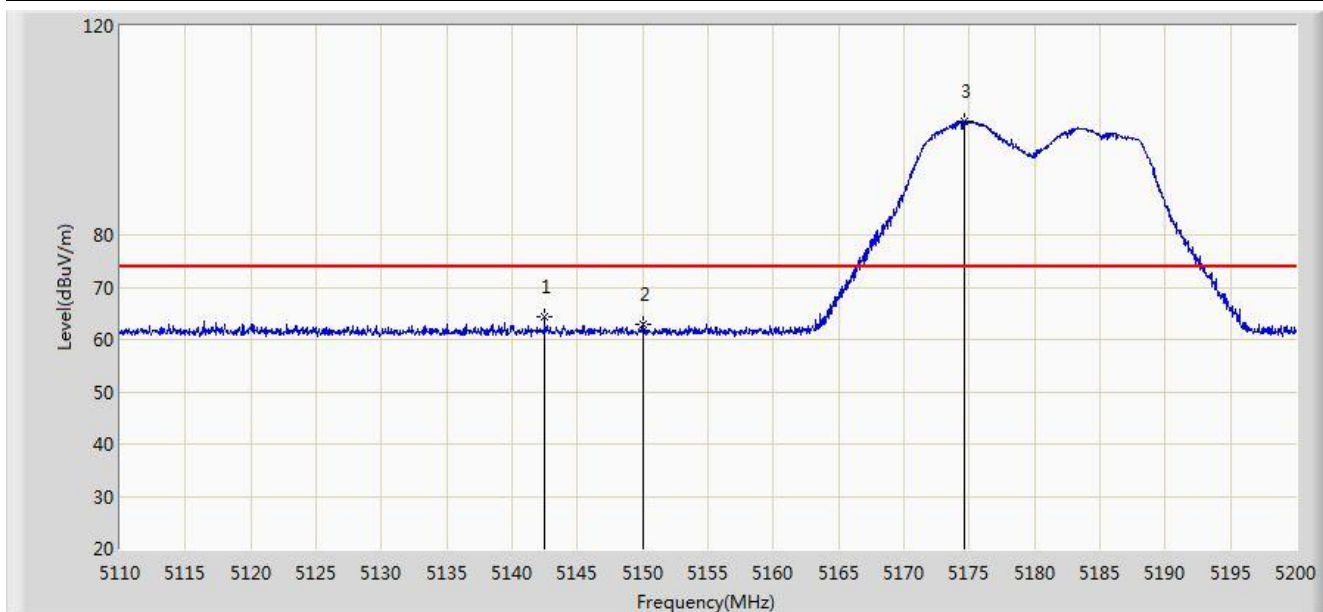

No	Flag	Mark	Frequency (MHz)	Measure Level (dBuV/m)	Reading Level (dBuV)	Over Limit (dB)	Limit (dBuV/m)	Factor (dB)	Type
1			5142.490	64.393	27.630	-9.607	74.000	36.763	PK
2			5150.000	62.934	26.182	-11.066	74.000	36.752	PK
3		*	5174.575	101.842	65.159	N/A	N/A	36.683	PK

Note: Measure Level (dBuV/m) = Reading Level (dBuV) + Factor (dB)

Factor (dB) = Cable Loss (dB) + Antenna Factor (dB/m).

Engineer: Roy Cheng	
Site: AC1	Time: 2014/07/15 - 20:19
Limit: FCC_Part15.209_RE(3m)	Margin: 0
Probe: BBHA9120D_1-18GHz	Polarity: Horizontal
EUT: WIFI dual band 4 GE LAN GPON HGU	Power: AC 120V/60Hz
Note: Mode 2: Transmit by 802.11n20 at channel 5180MHz Ant 0+1+2+3	

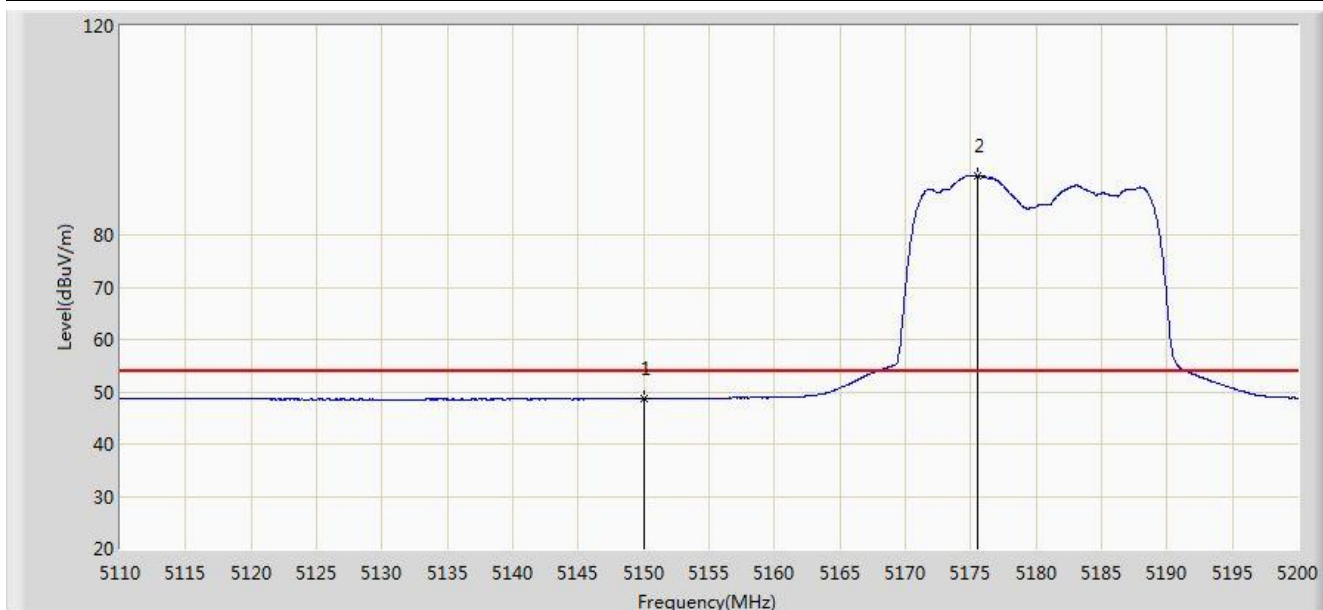

No	Flag	Mark	Frequency (MHz)	Measure Level (dBuV/m)	Reading Level (dBuV)	Over Limit (dB)	Limit (dBuV/m)	Factor (dB)	Type
1			5150.000	48.605	11.853	-5.395	54.000	36.752	AV
2		*	5175.475	91.292	54.612	N/A	N/A	36.680	AV

Note: Measure Level (dB μ V/m) = Reading Level (dB μ V) + Factor (dB)

Factor (dB) = Cable Loss (dB) + Antenna Factor (dB/m).

Engineer: Roy Cheng	
Site: AC1	Time: 2014/07/15 - 20:24
Limit: FCC_Part15.209_RE(3m)	Margin: 0
Probe: BBHA9120D_1-18GHz	Polarity: Vertical
EUT: WIFI dual band 4 GE LAN GPON HGU	Power: AC 120V/60Hz
Note: Mode 2: Transmit by 802.11n20 at channel 5180MHz Ant 0+1+2+3	

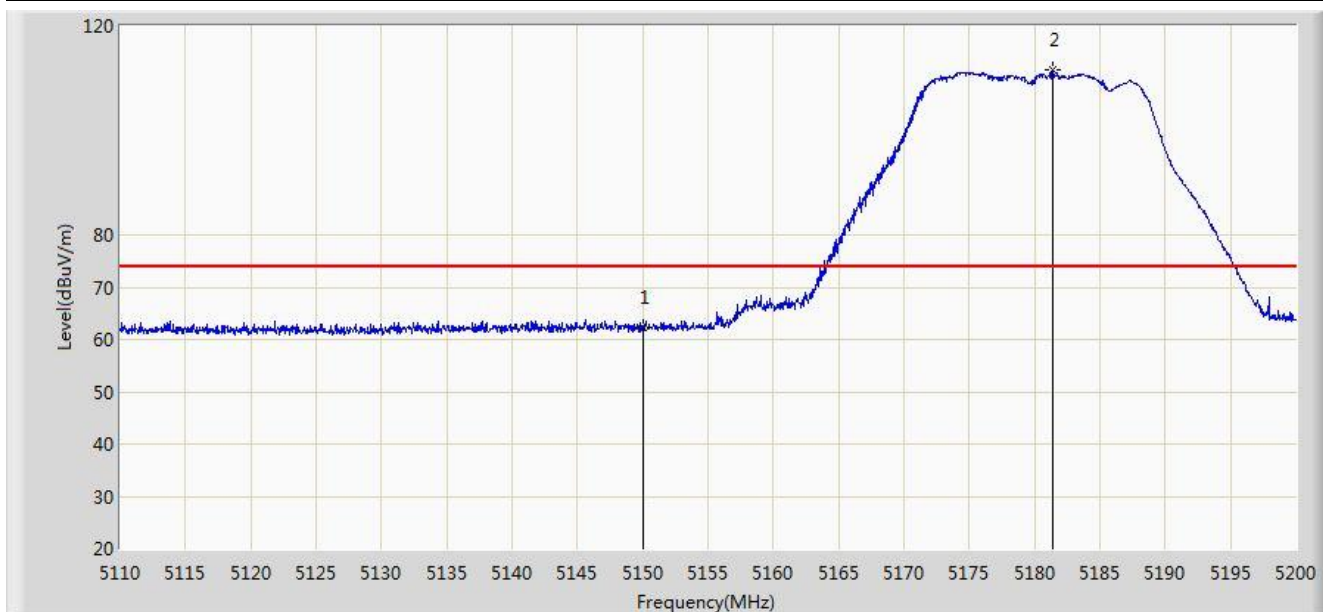

No	Flag	Mark	Frequency (MHz)	Measure Level (dBuV/m)	Reading Level (dBuV)	Over Limit (dB)	Limit (dBuV/m)	Factor (dB)	Type
1			5150.000	62.359	25.607	-11.641	74.000	36.752	PK
2		*	5181.415	111.600	74.939	N/A	N/A	36.661	PK

Note: Measure Level (dB μ V/m) = Reading Level (dB μ V) + Factor (dB)

Factor (dB) = Cable Loss (dB) + Antenna Factor (dB/m).

Engineer: Roy Cheng	
Site: AC1	Time: 2014/07/15 - 20:26
Limit: FCC_Part15.209_RE(3m)	Margin: 0
Probe: BBHA9120D_1-18GHz	Polarity: Vertical
EUT: WIFI dual band 4 GE LAN GPON HGU	Power: AC 120V/60Hz
Note: Mode 2: Transmit by 802.11n20 at channel 5180MHz Ant 0+1+2+3	

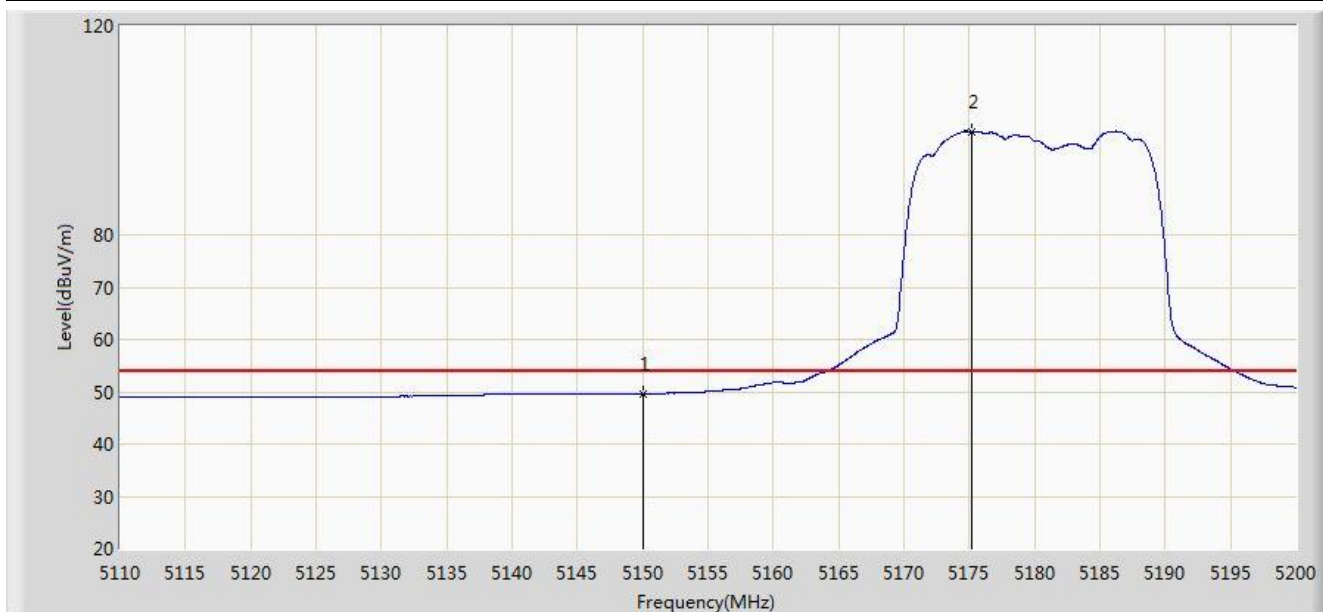

No	Flag	Mark	Frequency (MHz)	Measure Level (dBuV/m)	Reading Level (dBuV)	Over Limit (dB)	Limit (dBuV/m)	Factor (dB)	Type
1			5150.000	49.632	12.880	-4.368	54.000	36.752	AV
2		*	5175.160	99.707	63.026	N/A	N/A	36.681	AV

Note: Measure Level (dB μ V/m) = Reading Level (dB μ V) + Factor (dB)

Factor (dB) = Cable Loss (dB) + Antenna Factor (dB/m).

Engineer: Roy Cheng	
Site: AC1	Time: 2014/07/15 - 20:27
Limit: FCC_Part15.209_RE(3m)	Margin: 0
Probe: BBHA9120D_1-18GHz	Polarity: Horizontal
EUT: WIFI dual band 4 GE LAN GPON HGU	Power: AC 120V/60Hz
Note: Mode 2: Transmit by 802.11n20 at channel 5320MHz Ant 0+1+2+3	

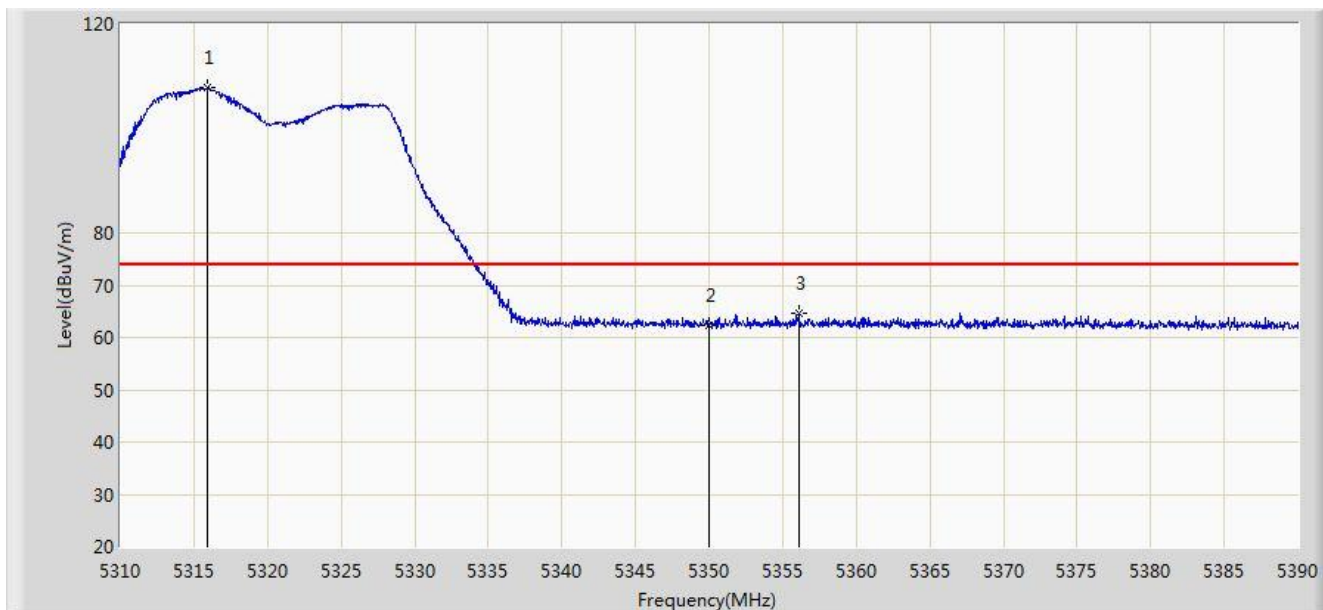

No	Flag	Mark	Frequency (MHz)	Measure Level (dBuV/m)	Reading Level (dBuV)	Over Limit (dB)	Limit (dBuV/m)	Factor (dB)	Type
1		*	5315.920	107.754	71.292	N/A	N/A	36.462	PK
2			5350.000	62.299	25.763	-11.701	74.000	36.536	PK
3			5356.120	64.528	27.978	-9.472	74.000	36.550	PK

Note: Measure Level (dBuV/m) = Reading Level (dBuV) + Factor (dB)

Factor (dB) = Cable Loss (dB) + Antenna Factor (dB/m).

Engineer: Roy Cheng	
Site: AC1	Time: 2014/07/15 - 20:29
Limit: FCC_Part15.209_RE(3m)	Margin: 0
Probe: BBHA9120D_1-18GHz	Polarity: Horizontal
EUT: WIFI dual band 4 GE LAN GPON HGU	Power: AC 120V/60Hz
Note: Mode 2: Transmit by 802.11n20 at channel 5320MHz Ant 0+1+2+3	

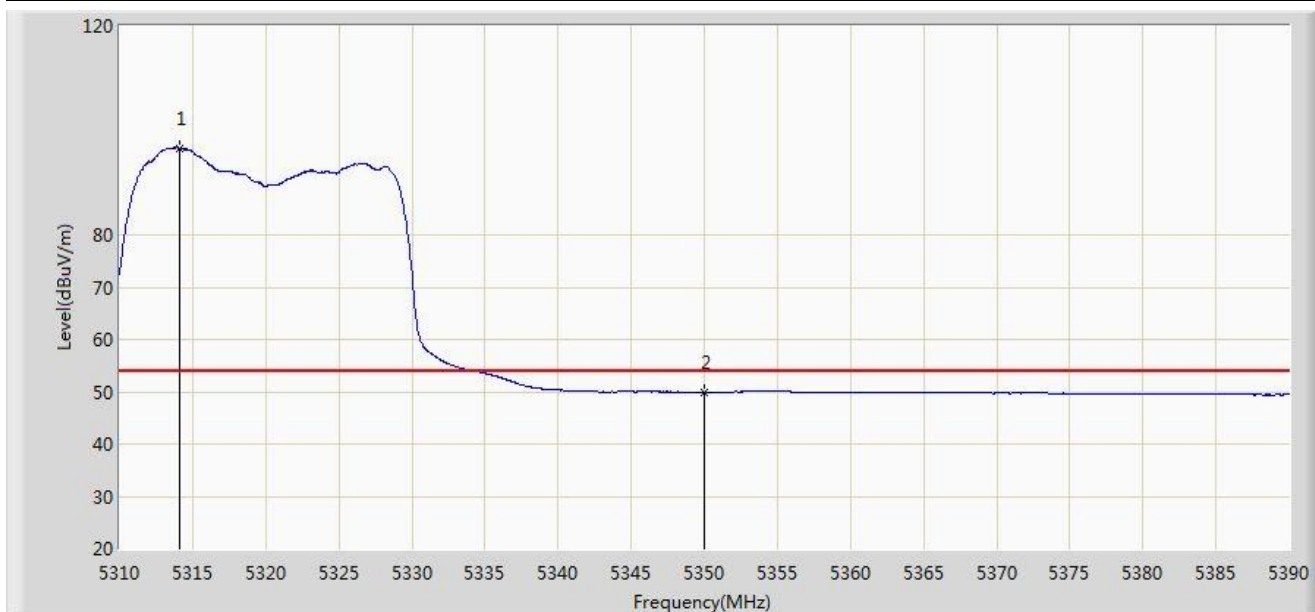

No	Flag	Mark	Frequency (MHz)	Measure Level (dBuV/m)	Reading Level (dBuV)	Over Limit (dB)	Limit (dBuV/m)	Factor (dB)	Type
1		*	5314.080	96.580	60.122	N/A	N/A	36.458	AV
2			5350.000	49.910	13.374	-4.090	54.000	36.536	AV

Note: Measure Level (dB μ V/m) = Reading Level (dB μ V) + Factor (dB)

Factor (dB) = Cable Loss (dB) + Antenna Factor (dB/m).

Engineer: Roy Cheng	
Site: AC1	Time: 2014/07/15 - 20:32
Limit: FCC_Part15.209_RE(3m)	Margin: 0
Probe: BBHA9120D_1-18GHz	Polarity: Vertical
EUT: WIFI dual band 4 GE LAN GPON HGU	Power: AC 120V/60Hz
Note: Mode 2: Transmit by 802.11n20 at channel 5320MHz Ant 0+1+2+3	

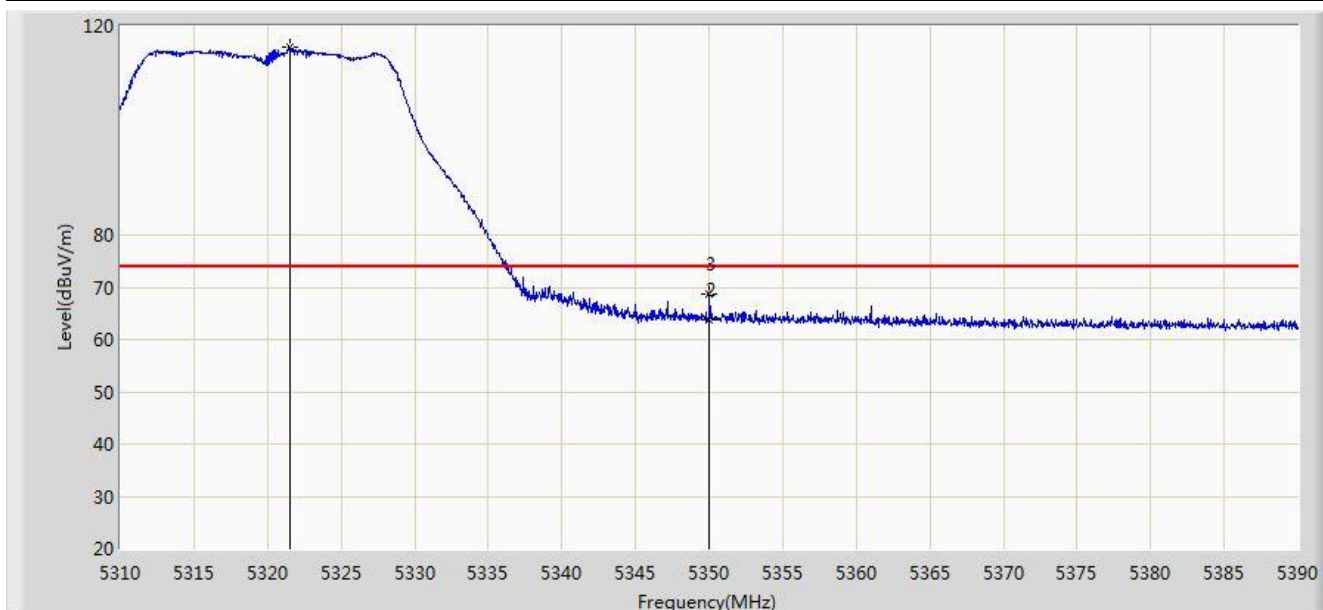

No	Flag	Mark	Frequency (MHz)	Measure Level (dBuV/m)	Reading Level (dBuV)	Over Limit (dB)	Limit (dBuV/m)	Factor (dB)	Type
1		*	5321.560	115.842	79.367	N/A	N/A	36.475	PK
2			5350.000	63.677	27.141	-10.323	74.000	36.536	PK
3			5350.040	68.667	32.131	-5.333	74.000	36.536	PK

Note: Measure Level (dBuV/m) = Reading Level (dBuV) + Factor (dB)

Factor (dB) = Cable Loss (dB) + Antenna Factor (dB/m).

Engineer: Roy Cheng	
Site: AC1	Time: 2014/07/15 - 20:34
Limit: FCC_Part15.209_RE(3m)	Margin: 0
Probe: BBHA9120D_1-18GHz	Polarity: Vertical
EUT: WIFI dual band 4 GE LAN GPON HGU	Power: AC 120V/60Hz
Note: Mode 2: Transmit by 802.11n20 at channel 5320MHz Ant 0+1+2+3	

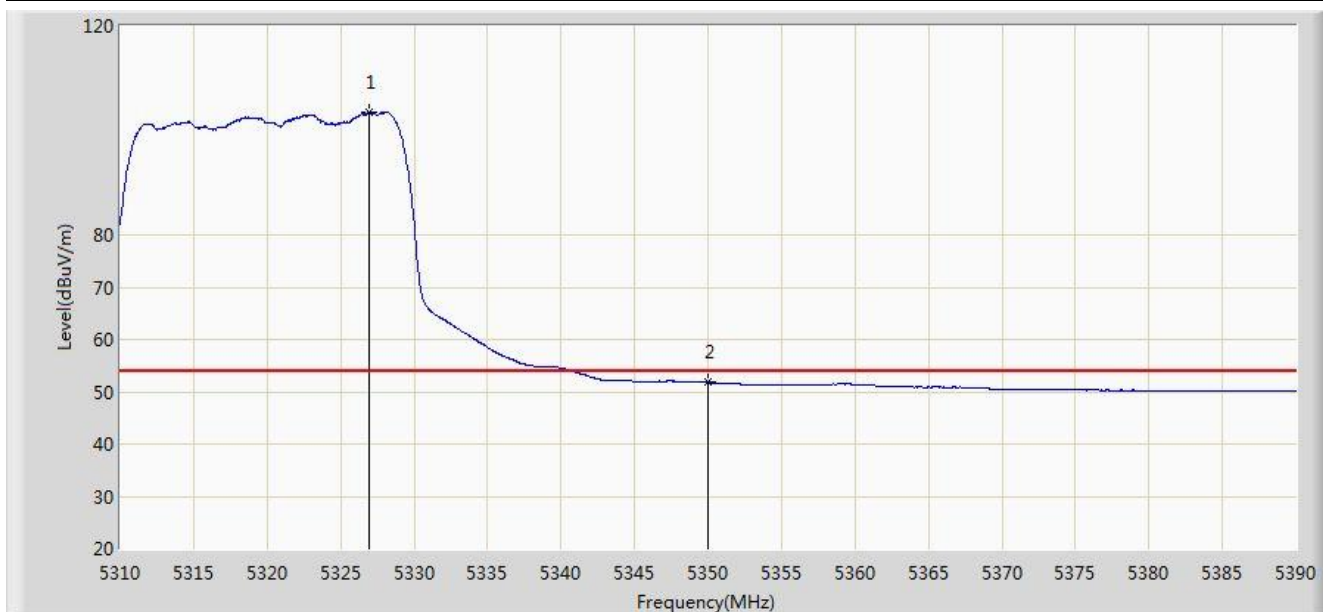

No	Flag	Mark	Frequency (MHz)	Measure Level (dBuV/m)	Reading Level (dBuV)	Over Limit (dB)	Limit (dBuV/m)	Factor (dB)	Type
1		*	5326.920	103.437	66.950	N/A	N/A	36.487	AV
2			5350.000	51.755	15.219	-2.245	54.000	36.536	AV

Note: Measure Level (dB μ V/m) = Reading Level (dB μ V) + Factor (dB)

Factor (dB) = Cable Loss (dB) + Antenna Factor (dB/m).

Engineer: Roy Cheng	
Site: AC1	Time: 2014/07/15 - 20:35
Limit: FCC_Part15.209_RE(3m)	Margin: 0
Probe: BBHA9120D_1-18GHz	Polarity: Horizontal
EUT: WIFI dual band 4 GE LAN GPON HGU	Power: AC 120V/60Hz
Note: Mode 2: Transmit by 802.11n20 at channel 5500MHz Ant 0+1+2+3	

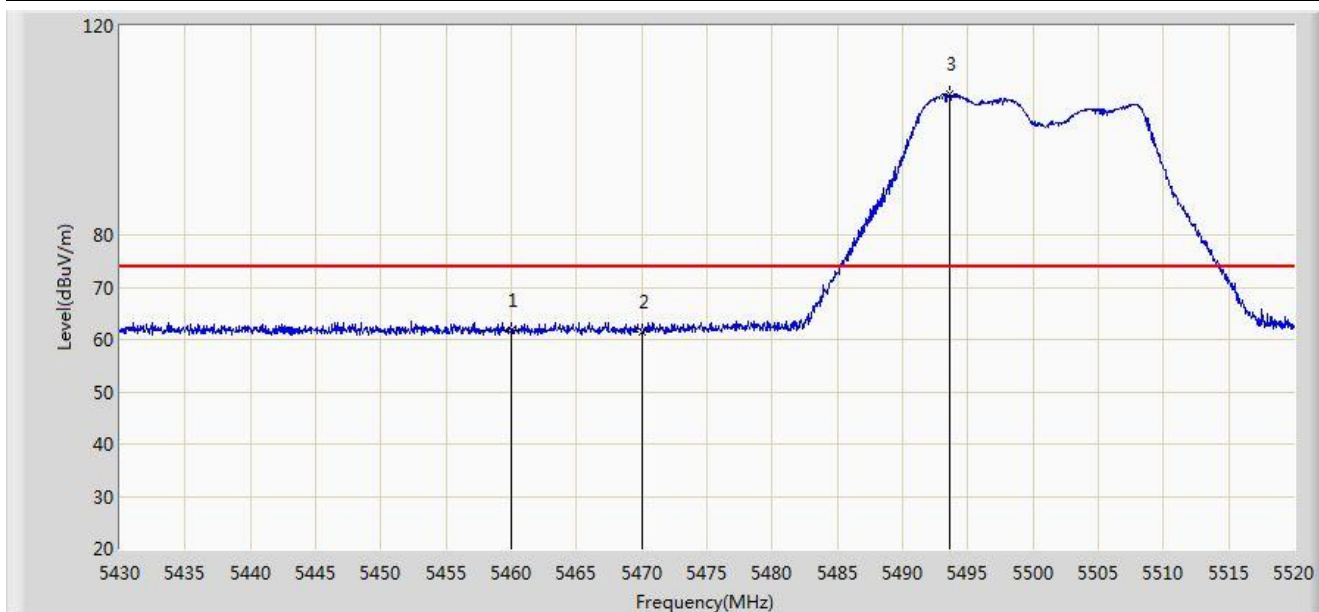

No	Flag	Mark	Frequency (MHz)	Measure Level (dBuV/m)	Reading Level (dBuV)	Over Limit (dB)	Limit (dBuV/m)	Factor (dB)	Type
1			5460.000	61.769	24.959	-12.231	74.000	36.810	PK
2			5470.000	61.467	24.642	-12.533	74.000	36.825	PK
3		*	5493.585	106.819	69.956	N/A	N/A	36.863	PK

Note: Measure Level (dBuV/m) = Reading Level (dBuV) + Factor (dB)

Factor (dB) = Cable Loss (dB) + Antenna Factor (dB/m).

Engineer: Roy Cheng	
Site: AC1	Time: 2014/07/15 - 20:37
Limit: FCC_Part15.209_RE(3m)	Margin: 0
Probe: BBHA9120D_1-18GHz	Polarity: Horizontal
EUT: WIFI dual band 4 GE LAN GPON HGU	Power: AC 120V/60Hz
Note: Mode 2: Transmit by 802.11n20 at channel 5500MHz Ant 0+1+2+3	

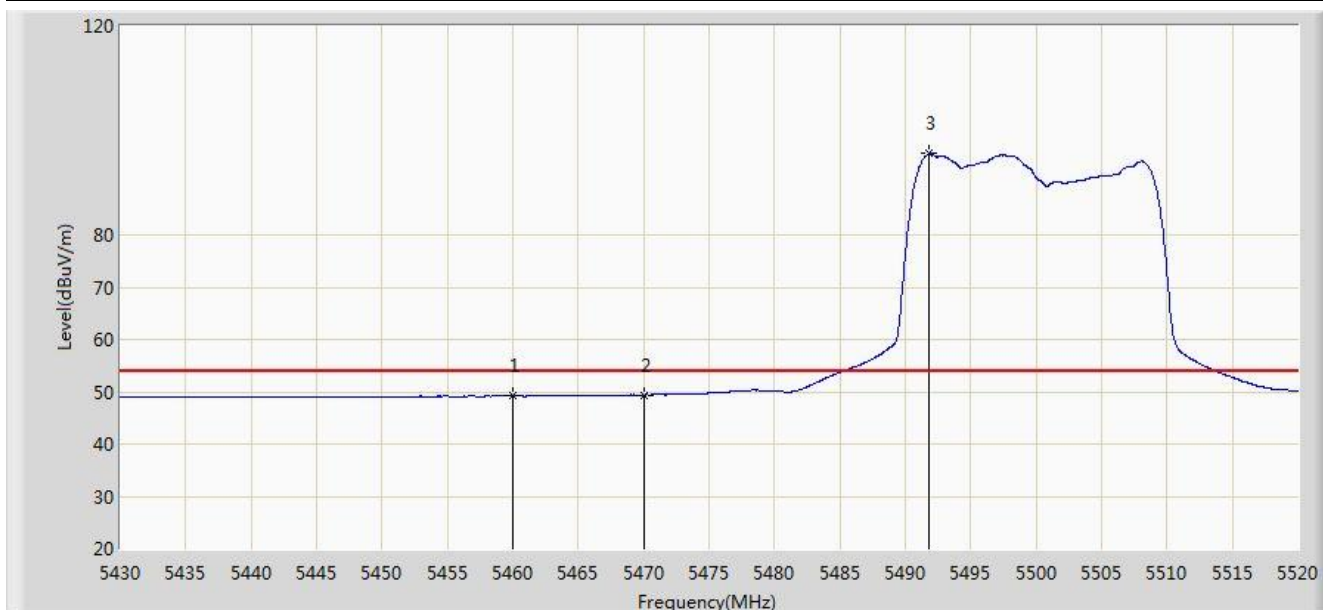

No	Flag	Mark	Frequency (MHz)	Measure Level (dBuV/m)	Reading Level (dBuV)	Over Limit (dB)	Limit (dBuV/m)	Factor (dB)	Type
1			5460.000	49.176	12.366	-4.824	54.000	36.810	AV
2			5470.000	49.385	12.560	-4.615	54.000	36.825	AV
3		*	5491.830	95.516	58.656	N/A	N/A	36.859	AV

Note: Measure Level (dBuV/m) = Reading Level (dBuV) + Factor (dB)

Factor (dB) = Cable Loss (dB) + Antenna Factor (dB/m).

Engineer: Roy Cheng	
Site: AC1	Time: 2014/07/15 - 20:40
Limit: FCC_Part15.209_RE(3m)	Margin: 0
Probe: BBHA9120D_1-18GHz	Polarity: Vertical
EUT: WIFI dual band 4 GE LAN GPON HGU	Power: AC 120V/60Hz
Note: Mode 2: Transmit by 802.11n20 at channel 5500MHz Ant 0+1+2+3	

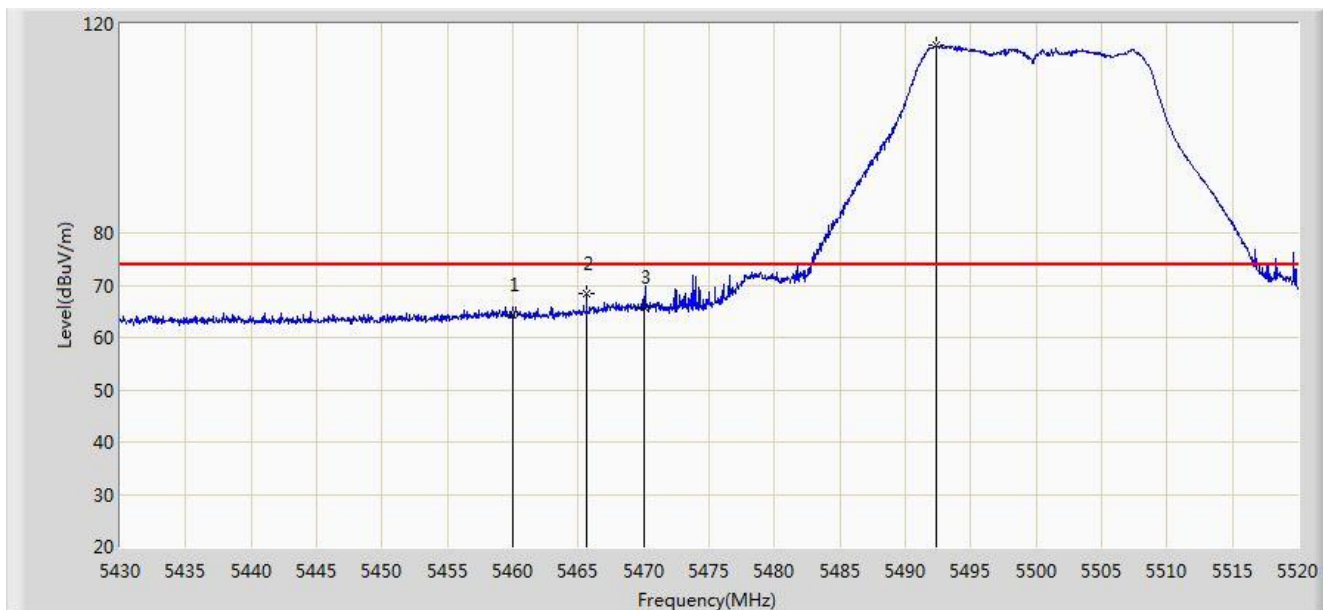

No	Flag	Mark	Frequency (MHz)	Measure Level (dBuV/m)	Reading Level (dBuV)	Over Limit (dB)	Limit (dBuV/m)	Factor (dB)	Type
1			5460.000	64.347	27.537	-9.653	74.000	36.810	PK
2			5465.640	68.550	31.732	-5.450	74.000	36.818	PK
3			5470.000	65.732	28.907	-8.268	74.000	36.825	PK
4		*	5492.370	115.843	78.982	N/A	N/A	36.861	PK

Note: Measure Level (dB μ V/m) = Reading Level (dB μ V) + Factor (dB)

Factor (dB) = Cable Loss (dB) + Antenna Factor (dB/m).

Engineer: Roy Cheng	
Site: AC1	Time: 2014/07/15 - 20:54
Limit: FCC_Part15.209_RE(3m)	Margin: 0
Probe: BBHA9120D_1-18GHz	Polarity: Vertical
EUT: WIFI dual band 4 GE LAN GPON HGU	Power: AC 120V/60Hz
Note: Mode 2: Transmit by 802.11n20 at channel 5500MHz Ant 0+1+2+3	

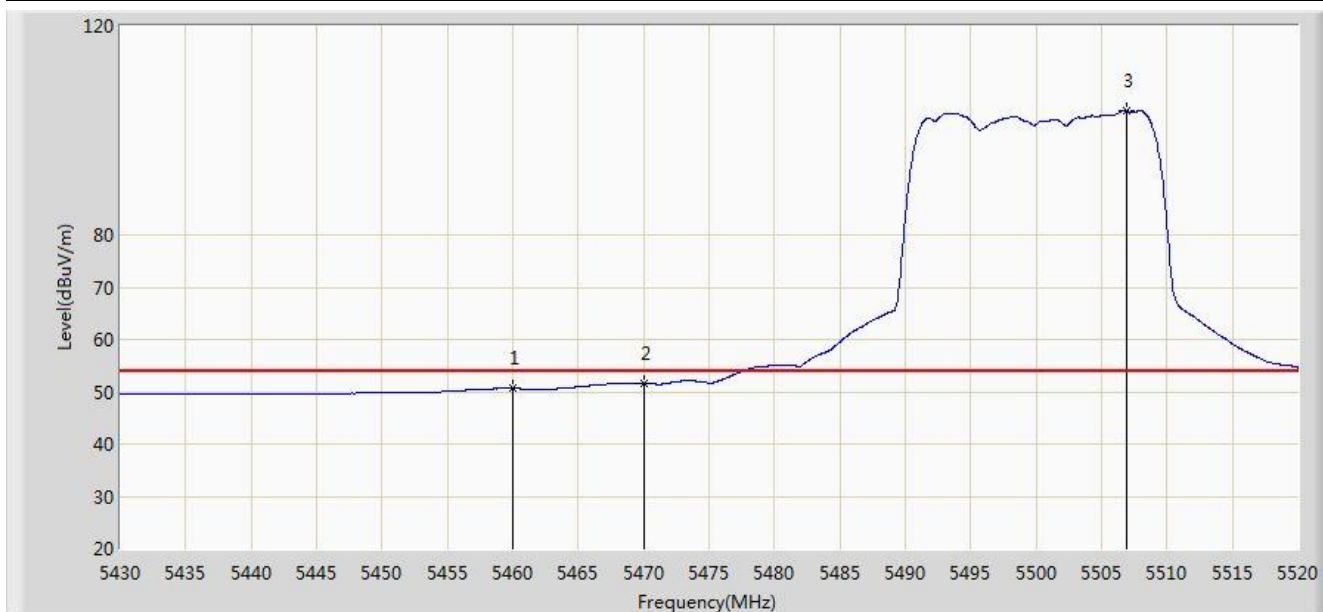

No	Flag	Mark	Frequency (MHz)	Measure Level (dBuV/m)	Reading Level (dBuV)	Over Limit (dB)	Limit (dBuV/m)	Factor (dB)	Type
1			5460.000	50.692	13.882	-3.308	54.000	36.810	AV
2			5470.000	51.547	14.722	-2.453	54.000	36.825	AV
3		*	5506.950	103.809	66.921	N/A	N/A	36.888	AV

Note: Measure Level (dBuV/m) = Reading Level (dBuV) + Factor (dB)

Factor (dB) = Cable Loss (dB) + Antenna Factor (dB/m).

Engineer: Roy Cheng	
Site: AC1	Time: 2014/07/15 - 21:31
Limit: FCC_Part15.209_RE(3m)	Margin: 0
Probe: BBHA9120D_1-18GHz	Polarity: Horizontal
EUT: WIFI dual band 4 GE LAN GPON HGU	Power: AC 120V/60Hz
Note: Mode 2: Transmit by 802.11n20 at channel 5700MHz Ant 0+1+2+3	

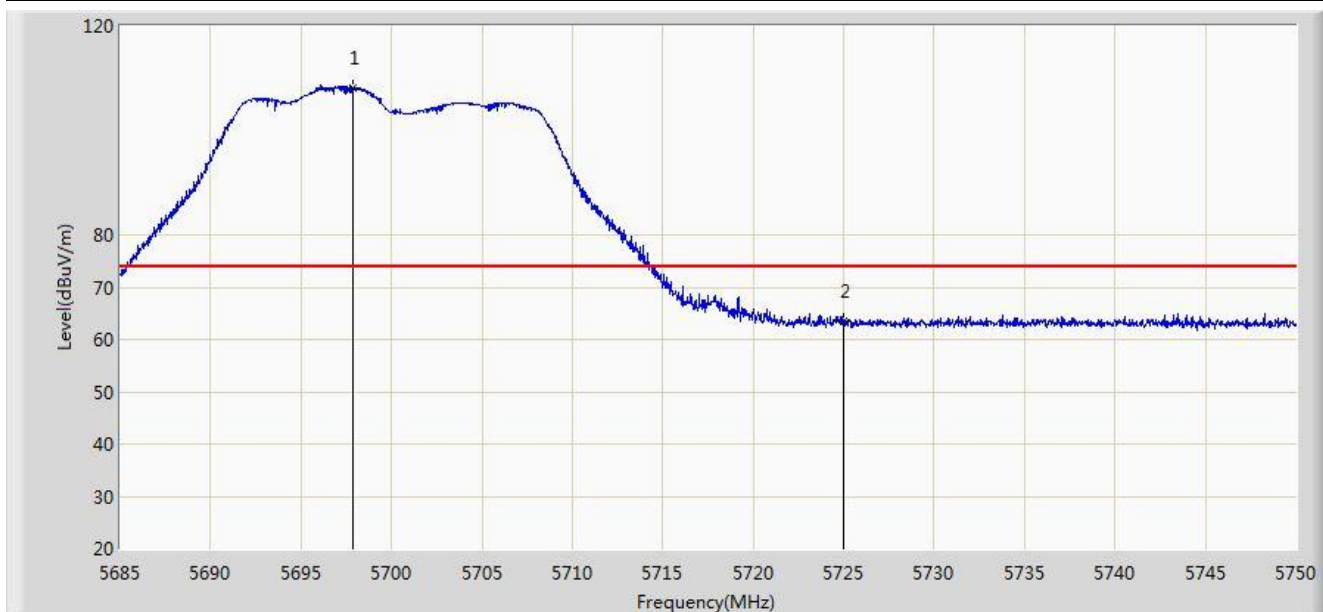

No	Flag	Mark	Frequency (MHz)	Measure Level (dBuV/m)	Reading Level (dBuV)	Over Limit (dB)	Limit (dBuV/m)	Factor (dB)	Type
1		*	5697.902	108.237	71.042	N/A	N/A	37.195	PK
2			5725.000	63.580	26.275	-10.420	74.000	37.305	PK

Note: Measure Level (dB μ V/m) = Reading Level (dB μ V) + Factor (dB)

Factor (dB) = Cable Loss (dB) + Antenna Factor (dB/m).

Engineer: Roy Cheng	
Site: AC1	Time: 2014/07/15 - 21:42
Limit: FCC_Part15.209_RE(3m)	Margin: 0
Probe: BBHA9120D_1-18GHz	Polarity: Vertical
EUT: WIFI dual band 4 GE LAN GPON HGU	Power: AC 120V/60Hz
Note: Mode 2: Transmit by 802.11n20 at channel 5700MHz Ant 0+1+2+3 Power=12	

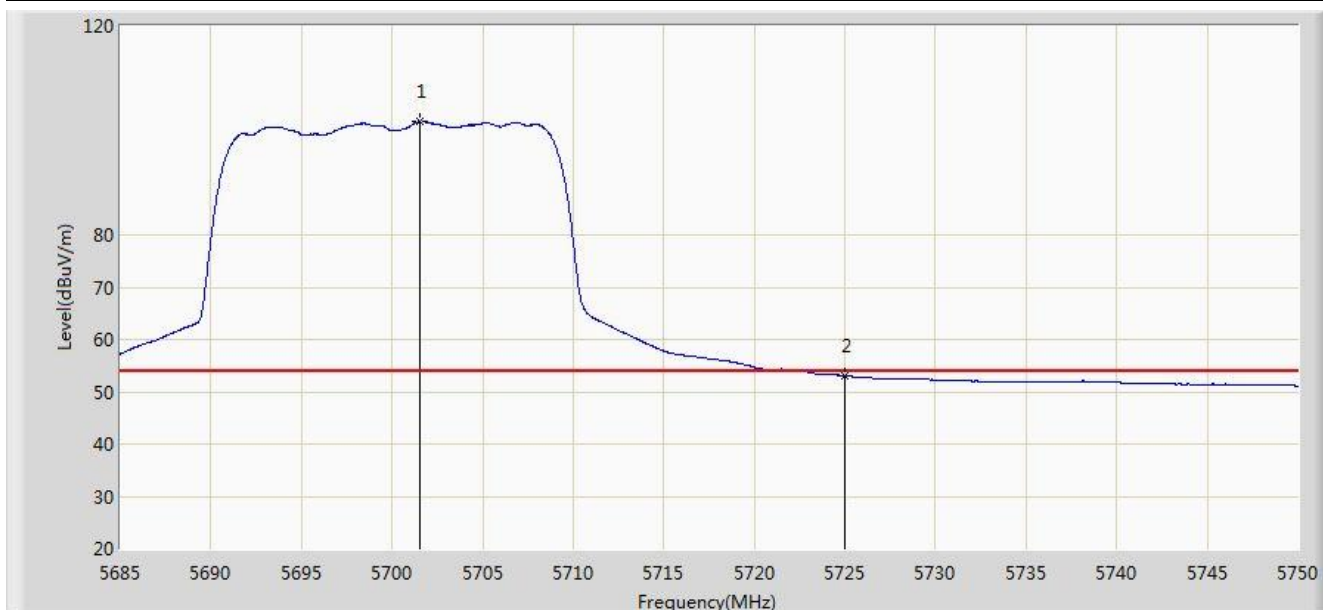

No	Flag	Mark	Frequency (MHz)	Measure Level (dBuV/m)	Reading Level (dBuV)	Over Limit (dB)	Limit (dBuV/m)	Factor (dB)	Type
1		*	5701.542	101.602	64.395	N/A	N/A	37.207	AV
2			5725.000	53.091	15.786	-0.909	54.000	37.305	AV

Note: Measure Level (dB μ V/m) = Reading Level (dB μ V) + Factor (dB)

Factor (dB) = Cable Loss (dB) + Antenna Factor (dB/m).

Engineer: Roy Cheng	
Site: AC1	Time: 2014/07/15 - 21:45
Limit: FCC_Part15.209_RE(3m)	Margin: 0
Probe: BBHA9120D_1-18GHz	Polarity: Vertical
EUT: WIFI dual band 4 GE LAN GPON HGU	Power: AC 120V/60Hz
Note: Mode 2: Transmit by 802.11n20 at channel 5700MHz Ant 0+1+2+3 Power=12	

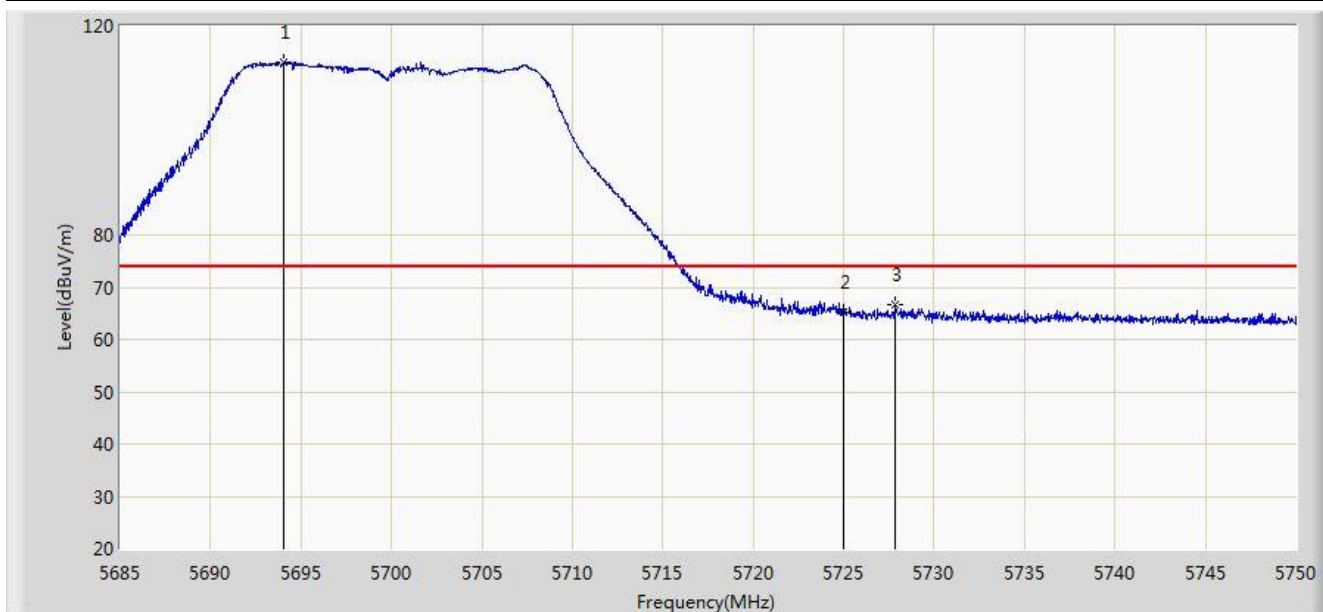

No	Flag	Mark	Frequency (MHz)	Measure Level (dBuV/m)	Reading Level (dBuV)	Over Limit (dB)	Limit (dBuV/m)	Factor (dB)	Type
1		*	5694.067	113.001	75.819	N/A	N/A	37.182	PK
2			5725.000	65.247	27.942	-8.753	74.000	37.305	PK
3			5727.868	66.653	29.337	-7.347	74.000	37.316	PK

Note: Measure Level (dBuV/m) = Reading Level (dBuV) + Factor (dB)

Factor (dB) = Cable Loss (dB) + Antenna Factor (dB/m).

Engineer: Roy Cheng	
Site: AC1	Time: 2014/07/15 - 21:48
Limit: FCC_Part15.209_RE(3m)	Margin: 0
Probe: BBHA9120D_1-18GHz	Polarity: Horizontal
EUT: WIFI dual band 4 GE LAN GPON HGU	Power: AC 120V/60Hz
Note: Mode 3: Transmit by 802.11ac20 at channel 5180MHz Ant 0+1+2+3	

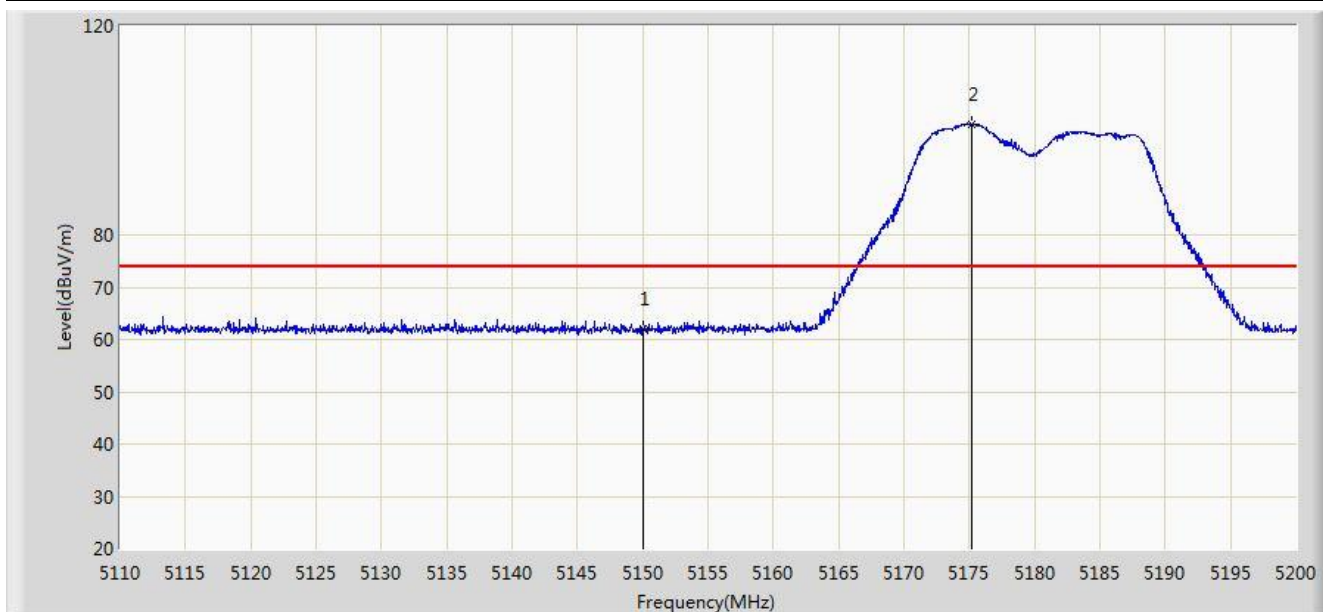

No	Flag	Mark	Frequency (MHz)	Measure Level (dBuV/m)	Reading Level (dBuV)	Over Limit (dB)	Limit (dBuV/m)	Factor (dB)	Type
1			5150.000	61.935	25.183	-12.065	74.000	36.752	PK
2		*	5175.160	101.231	64.550	N/A	N/A	36.681	PK

Note: Measure Level (dB μ V/m) = Reading Level (dB μ V) + Factor (dB)

Factor (dB) = Cable Loss (dB) + Antenna Factor (dB/m).

Engineer: Roy Cheng	
Site: AC1	Time: 2014/07/15 - 21:51
Limit: FCC_Part15.209_RE(3m)	Margin: 0
Probe: BBHA9120D_1-18GHz	Polarity: Horizontal
EUT: WIFI dual band 4 GE LAN GPON HGU	Power: AC 120V/60Hz
Note: Mode 3: Transmit by 802.11ac20 at channel 5180MHz Ant 0+1+2+3	

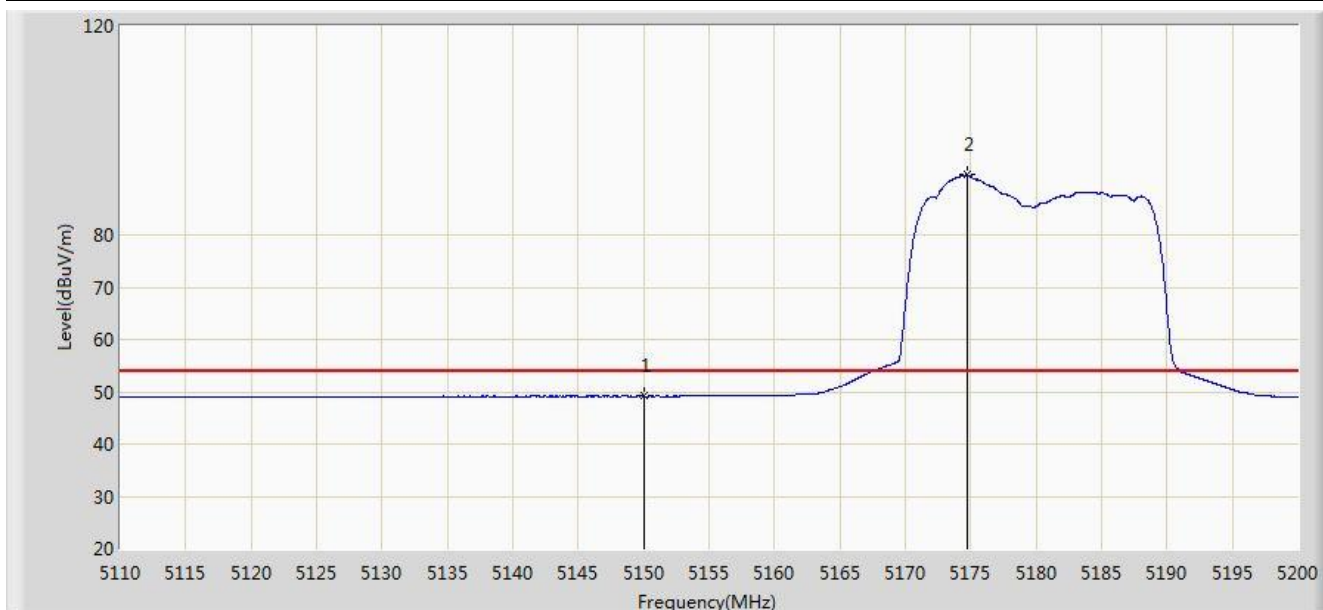

No	Flag	Mark	Frequency (MHz)	Measure Level (dBuV/m)	Reading Level (dBuV)	Over Limit (dB)	Limit (dBuV/m)	Factor (dB)	Type
1			5150.000	49.132	12.380	-4.868	54.000	36.752	AV
2		*	5174.755	91.454	54.772	N/A	N/A	36.682	AV

Note: Measure Level (dB μ V/m) = Reading Level (dB μ V) + Factor (dB)

Factor (dB) = Cable Loss (dB) + Antenna Factor (dB/m).

Engineer: Roy Cheng	
Site: AC1	Time: 2014/07/15 - 21:54
Limit: FCC_Part15.209_RE(3m)	Margin: 0
Probe: BBHA9120D_1-18GHz	Polarity: Vertical
EUT: WIFI dual band 4 GE LAN GPON HGU	Power: AC 120V/60Hz
Note: Mode 3: Transmit by 802.11ac20 at channel 5180MHz Ant 0+1+2+3	

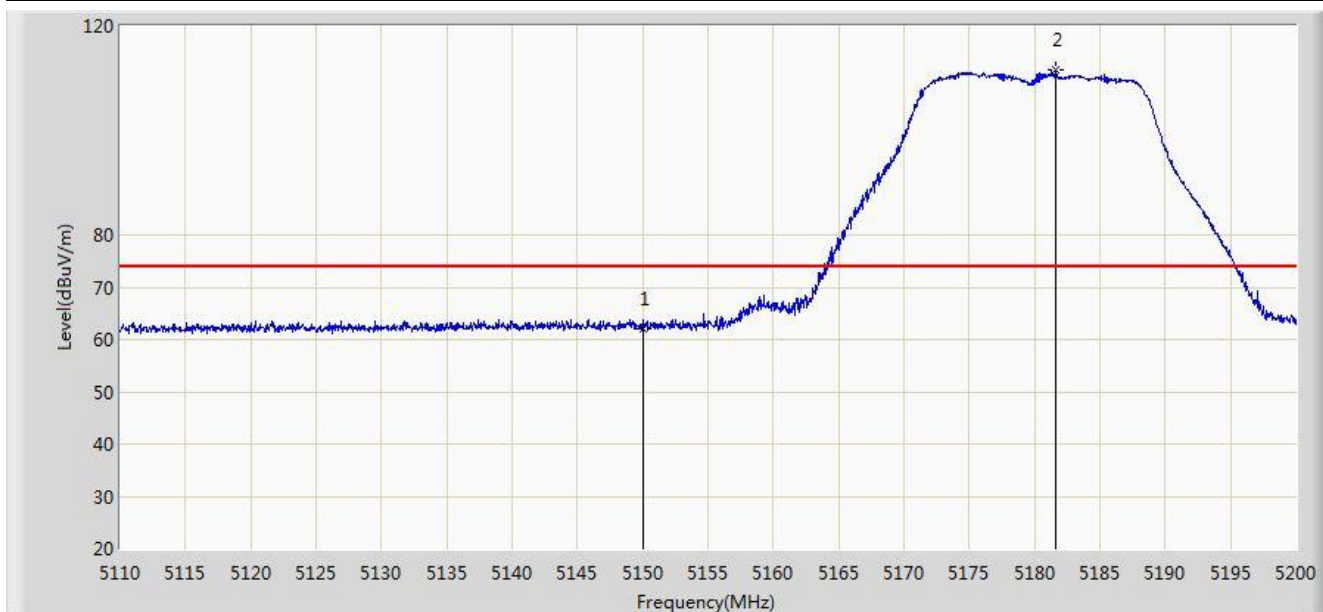

No	Flag	Mark	Frequency (MHz)	Measure Level (dBuV/m)	Reading Level (dBuV)	Over Limit (dB)	Limit (dBuV/m)	Factor (dB)	Type
1			5150.000	62.029	25.277	-11.971	74.000	36.752	PK
2		*	5181.595	111.603	74.943	N/A	N/A	36.661	PK

Note: Measure Level (dB μ V/m) = Reading Level (dB μ V) + Factor (dB)

Factor (dB) = Cable Loss (dB) + Antenna Factor (dB/m).

Engineer: Roy Cheng	
Site: AC1	Time: 2014/07/15 - 21:56
Limit: FCC_Part15.209_RE(3m)	Margin: 0
Probe: BBHA9120D_1-18GHz	Polarity: Vertical
EUT: WIFI dual band 4 GE LAN GPON HGU	Power: AC 120V/60Hz
Note: Mode 3: Transmit by 802.11ac20 at channel 5180MHz Ant 0+1+2+3	

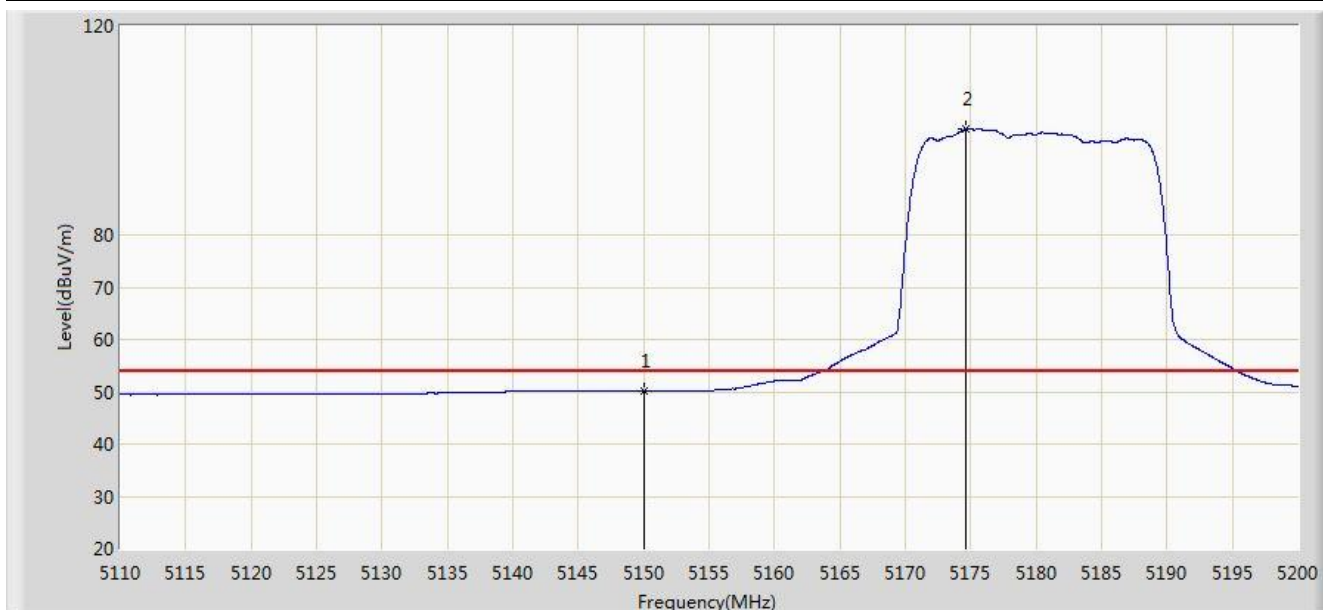

No	Flag	Mark	Frequency (MHz)	Measure Level (dBuV/m)	Reading Level (dBuV)	Over Limit (dB)	Limit (dBuV/m)	Factor (dB)	Type
1			5150.000	50.031	13.279	-3.969	54.000	36.752	AV
2		*	5174.665	100.288	63.606	N/A	N/A	36.682	AV

Note: Measure Level (dB μ V/m) = Reading Level (dB μ V) + Factor (dB)

Factor (dB) = Cable Loss (dB) + Antenna Factor (dB/m).

Engineer: Roy Cheng	
Site: AC1	Time: 2014/07/15 - 21:59
Limit: FCC_Part15.209_RE(3m)	Margin: 0
Probe: BBHA9120D_1-18GHz	Polarity: Horizontal
EUT: WIFI dual band 4 GE LAN GPON HGU	Power: AC 120V/60Hz
Note: Mode 3: Transmit by 802.11ac20 at channel 5320MHz Ant 0+1+2+3	

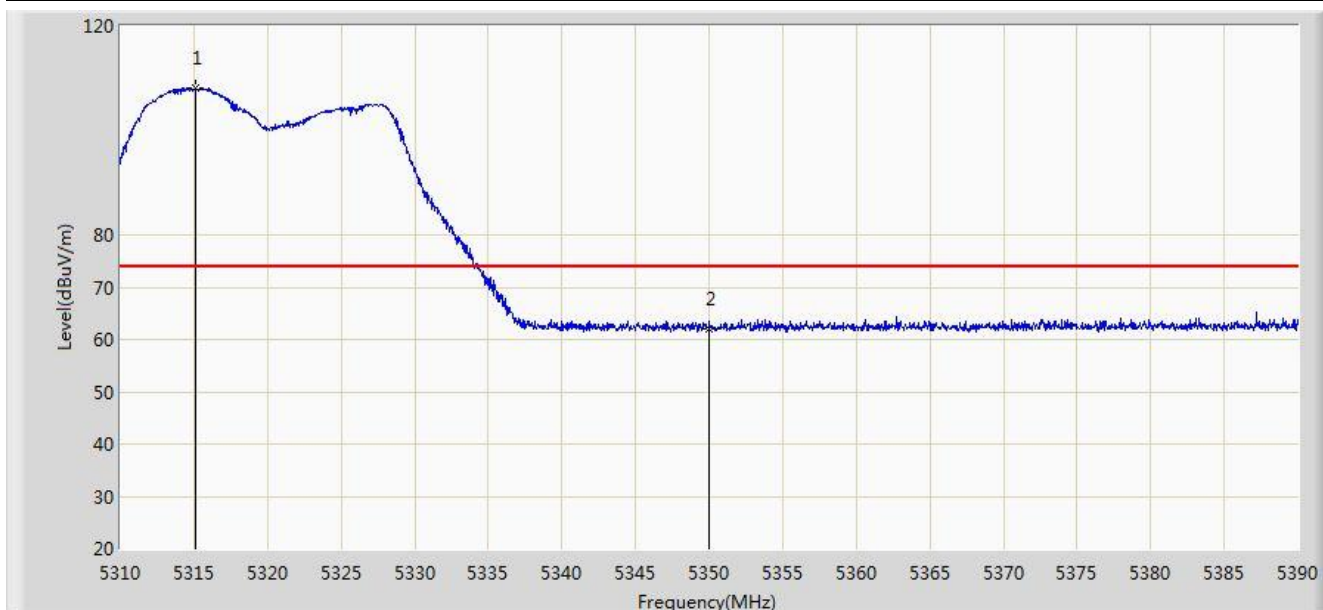

No	Flag	Mark	Frequency (MHz)	Measure Level (dBuV/m)	Reading Level (dBuV)	Over Limit (dB)	Limit (dBuV/m)	Factor (dB)	Type
1		*	5315.120	108.144	71.684	N/A	N/A	36.460	PK
2			5350.000	62.018	25.482	-11.982	74.000	36.536	PK

Note: Measure Level (dB μ V/m) = Reading Level (dB μ V) + Factor (dB)

Factor (dB) = Cable Loss (dB) + Antenna Factor (dB/m).

Engineer: Roy Cheng	
Site: AC1	Time: 2014/07/15 - 22:02
Limit: FCC_Part15.209_RE(3m)	Margin: 0
Probe: BBHA9120D_1-18GHz	Polarity: Horizontal
EUT: WIFI dual band 4 GE LAN GPON HGU	Power: AC 120V/60Hz
Note: Mode 3: Transmit by 802.11ac20 at channel 5320MHz Ant 0+1+2+3	

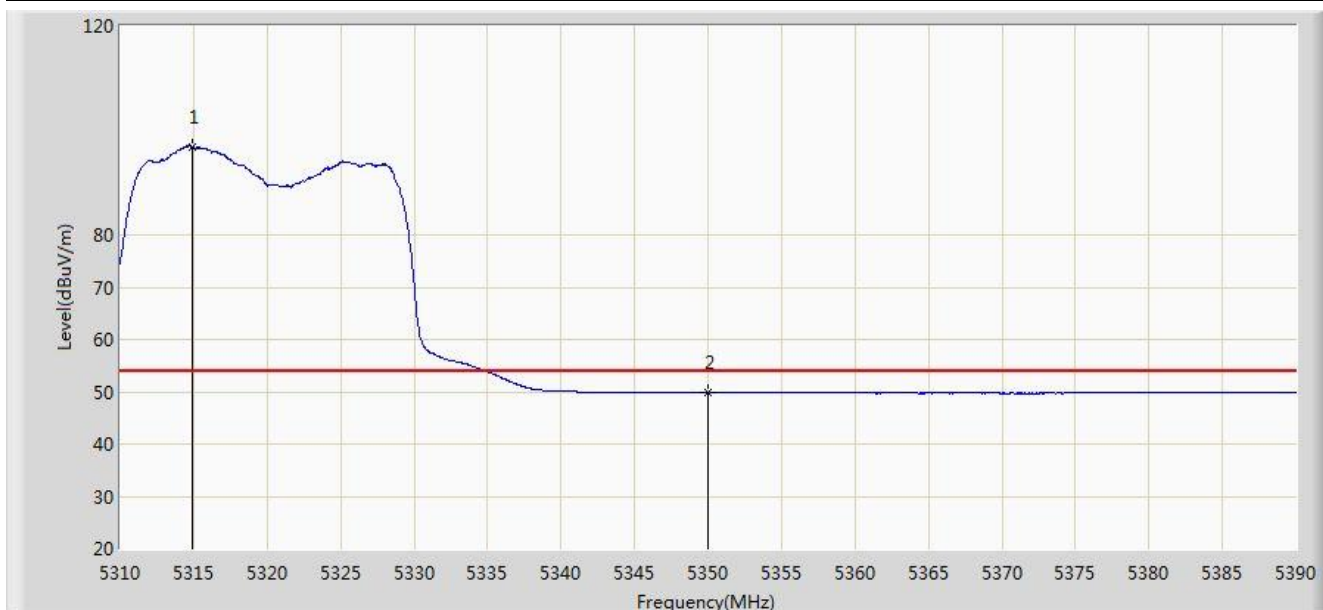

No	Flag	Mark	Frequency (MHz)	Measure Level (dBuV/m)	Reading Level (dBuV)	Over Limit (dB)	Limit (dBuV/m)	Factor (dB)	Type
1		*	5314.960	96.868	60.408	N/A	N/A	36.460	AV
2			5350.000	49.735	13.199	-4.265	54.000	36.536	AV

Note: Measure Level (dB μ V/m) = Reading Level (dB μ V) + Factor (dB)

Factor (dB) = Cable Loss (dB) + Antenna Factor (dB/m).

Engineer: Roy Cheng	
Site: AC1	Time: 2014/07/15 - 22:06
Limit: FCC_Part15.209_RE(3m)	Margin: 0
Probe: BBHA9120D_1-18GHz	Polarity: Vertical
EUT: WIFI dual band 4 GE LAN GPON HGU	Power: AC 120V/60Hz
Note: Mode 3: Transmit by 802.11ac20 at channel 5320MHz Ant 0+1+2+3	

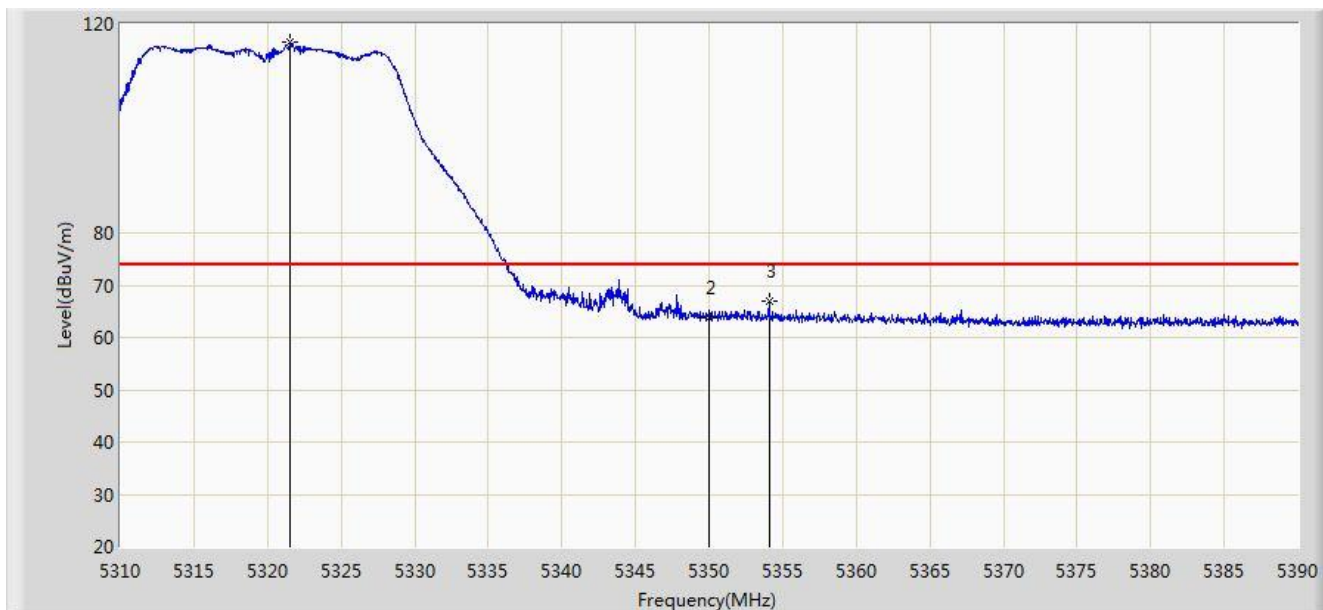

No	Flag	Mark	Frequency (MHz)	Measure Level (dBuV/m)	Reading Level (dBuV)	Over Limit (dB)	Limit (dBuV/m)	Factor (dB)	Type
1		*	5321.560	116.515	80.040	N/A	N/A	36.475	PK
2			5350.000	63.639	27.103	-10.361	74.000	36.536	PK
3			5354.080	66.995	30.449	-7.005	74.000	36.545	PK

Note: Measure Level (dBuV/m) = Reading Level (dBuV) + Factor (dB)

Factor (dB) = Cable Loss (dB) + Antenna Factor (dB/m).

Engineer: Roy Cheng	
Site: AC1	Time: 2014/07/15 - 22:07
Limit: FCC_Part15.209_RE(3m)	Margin: 0
Probe: BBHA9120D_1-18GHz	Polarity: Vertical
EUT: WIFI dual band 4 GE LAN GPON HGU	Power: AC 120V/60Hz
Note: Mode 3: Transmit by 802.11ac20 at channel 5320MHz Ant 0+1+2+3	

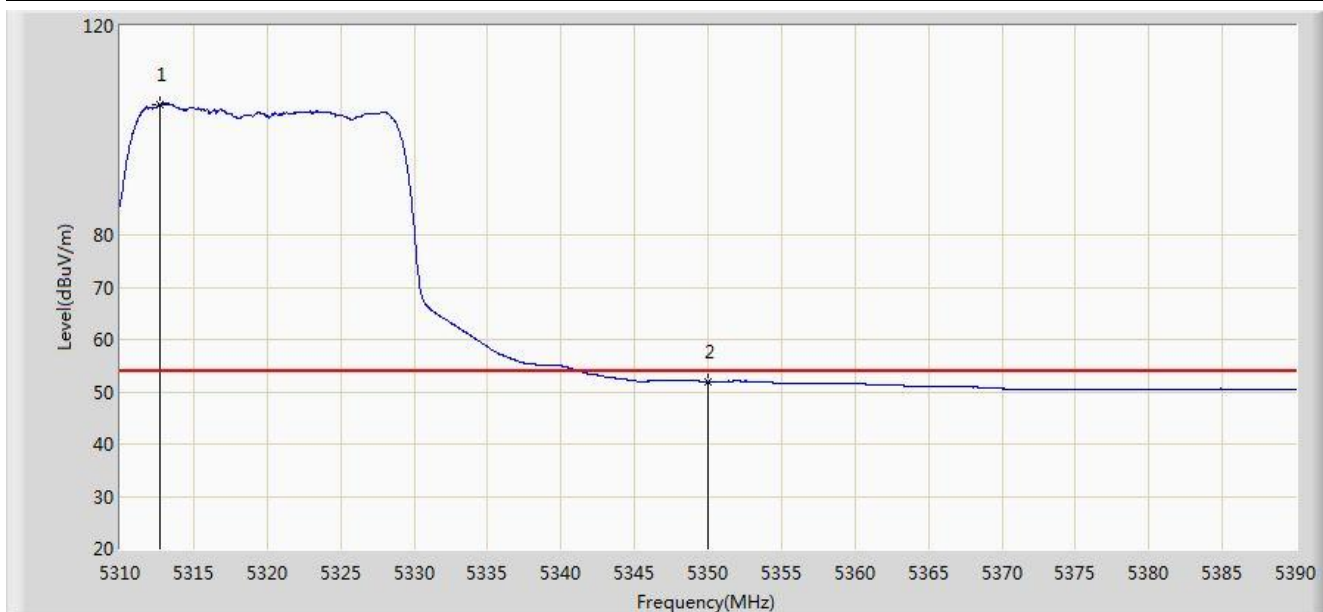

No	Flag	Mark	Frequency (MHz)	Measure Level (dBuV/m)	Reading Level (dBuV)	Over Limit (dB)	Limit (dBuV/m)	Factor (dB)	Type
1		*	5312.680	104.943	68.488	N/A	N/A	36.455	AV
2			5350.000	51.906	15.370	-2.094	54.000	36.536	AV

Note: Measure Level (dB μ V/m) = Reading Level (dB μ V) + Factor (dB)

Factor (dB) = Cable Loss (dB) + Antenna Factor (dB/m).

Engineer: Roy Cheng	
Site: AC1	Time: 2014/07/15 - 22:11
Limit: FCC_Part15.209_RE(3m)	Margin: 0
Probe: BBHA9120D_1-18GHz	Polarity: Horizontal
EUT: WIFI dual band 4 GE LAN GPON HGU	Power: AC 120V/60Hz
Note: Mode 3: Transmit by 802.11ac20 at channel 5500MHz Ant 0+1+2+3	

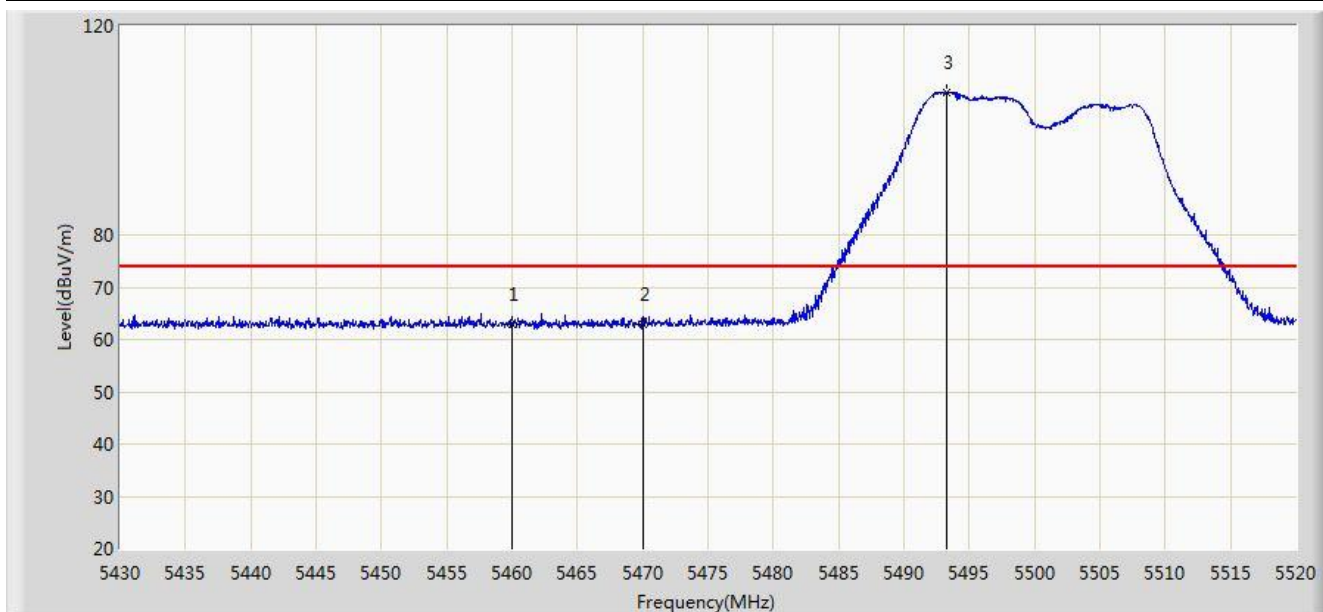

No	Flag	Mark	Frequency (MHz)	Measure Level (dBuV/m)	Reading Level (dBuV)	Over Limit (dB)	Limit (dBuV/m)	Factor (dB)	Type
1			5460.000	63.042	26.232	-10.958	74.000	36.810	PK
2			5470.000	62.853	26.028	-11.147	74.000	36.825	PK
3		*	5493.225	107.381	70.519	N/A	N/A	36.862	PK

Note: Measure Level (dBuV/m) = Reading Level (dBuV) + Factor (dB)

Factor (dB) = Cable Loss (dB) + Antenna Factor (dB/m).

Engineer: Roy Cheng	
Site: AC1	Time: 2014/07/15 - 22:14
Limit: FCC_Part15.209_RE(3m)	Margin: 0
Probe: BBHA9120D_1-18GHz	Polarity: Horizontal
EUT: WIFI dual band 4 GE LAN GPON HGU	Power: AC 120V/60Hz
Note: Mode 3: Transmit by 802.11ac20 at channel 5500MHz Ant 0+1+2+3	

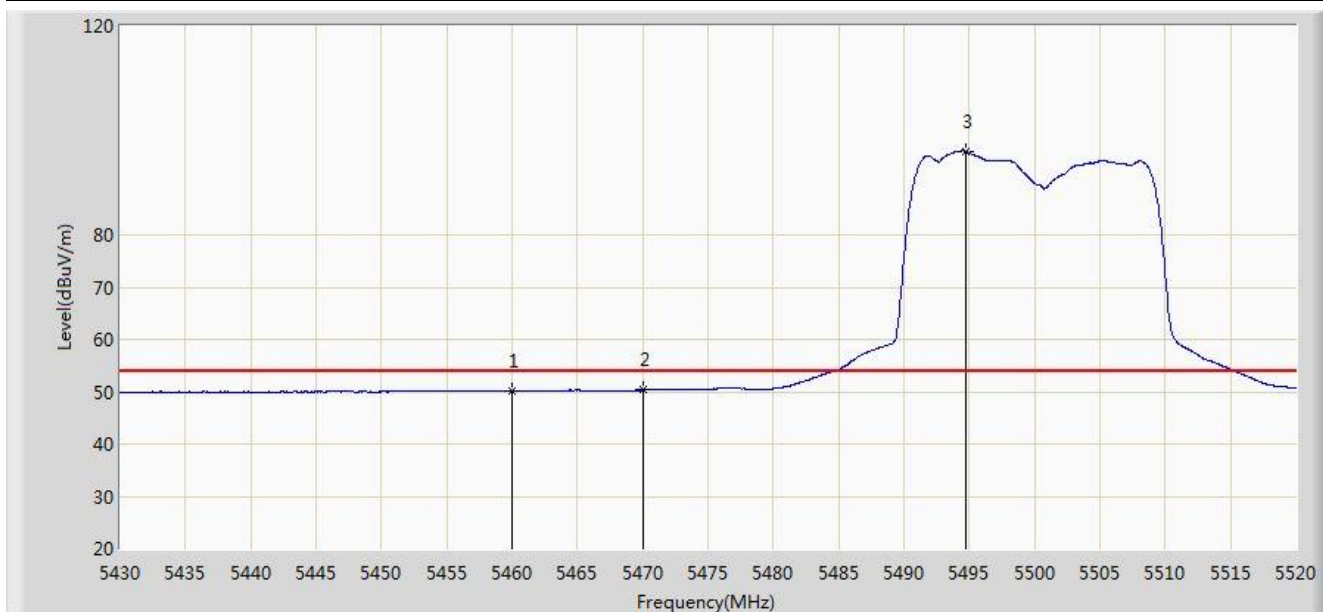

No	Flag	Mark	Frequency (MHz)	Measure Level (dBuV/m)	Reading Level (dBuV)	Over Limit (dB)	Limit (dBuV/m)	Factor (dB)	Type
1			5460.000	50.151	13.341	-3.849	54.000	36.810	AV
2			5470.000	50.334	13.509	-3.666	54.000	36.825	AV
3		*	5494.755	95.974	59.109	N/A	N/A	36.865	AV

Note: Measure Level (dBuV/m) = Reading Level (dBuV) + Factor (dB)

Factor (dB) = Cable Loss (dB) + Antenna Factor (dB/m).

Engineer: Roy Cheng	
Site: AC1	Time: 2014/07/15 - 22:20
Limit: FCC_Part15.209_RE(3m)	Margin: 0
Probe: BBHA9120D_1-18GHz	Polarity: Vertical
EUT: WIFI dual band 4 GE LAN GPON HGU	Power: AC 120V/60Hz
Note: Mode 3: Transmit by 802.11ac20 at channel 5500MHz Ant 0+1+2+3	

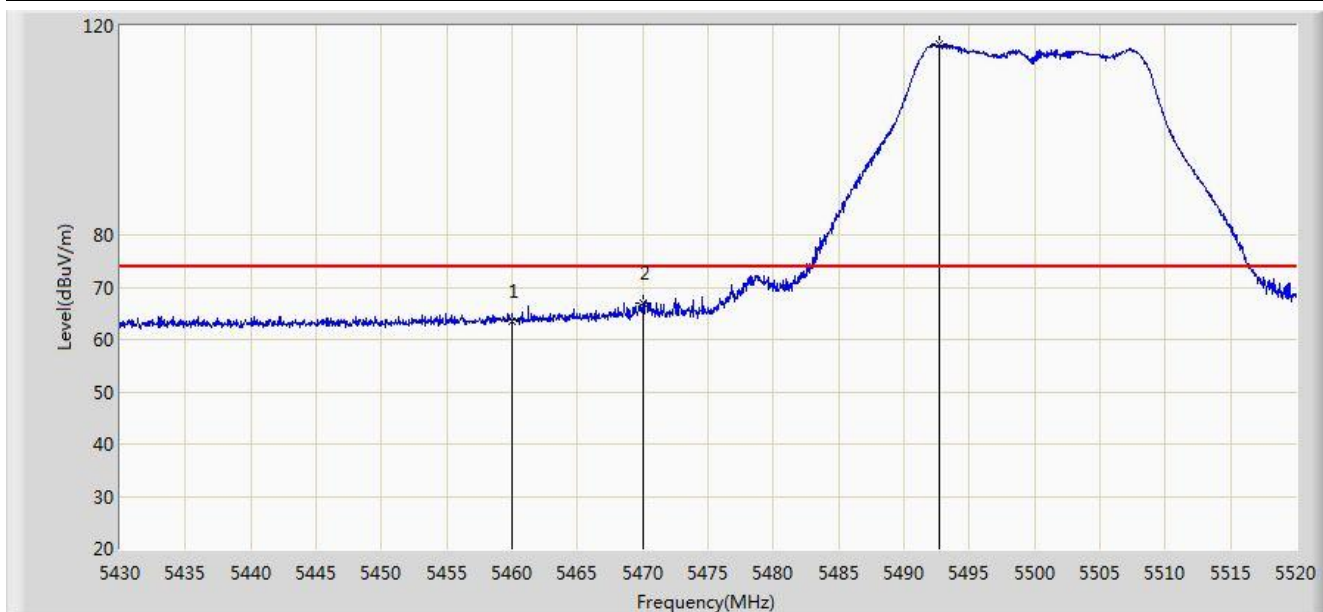

No	Flag	Mark	Frequency (MHz)	Measure Level (dBuV/m)	Reading Level (dBuV)	Over Limit (dB)	Limit (dBuV/m)	Factor (dB)	Type
1			5460.000	63.474	26.664	-10.526	74.000	36.810	PK
2			5470.000	66.896	30.071	-7.104	74.000	36.825	PK
3		*	5492.730	116.423	79.562	N/A	N/A	36.861	PK

Note: Measure Level (dBuV/m) = Reading Level (dBuV) + Factor (dB)

Factor (dB) = Cable Loss (dB) + Antenna Factor (dB/m).

Engineer: Roy Cheng	
Site: AC1	Time: 2014/07/15 - 22:21
Limit: FCC_Part15.209_RE(3m)	Margin: 0
Probe: BBHA9120D_1-18GHz	Polarity: Vertical
EUT: WIFI dual band 4 GE LAN GPON HGU	Power: AC 120V/60Hz
Note: Mode 3: Transmit by 802.11ac20 at channel 5500MHz Ant 0+1+2+3	

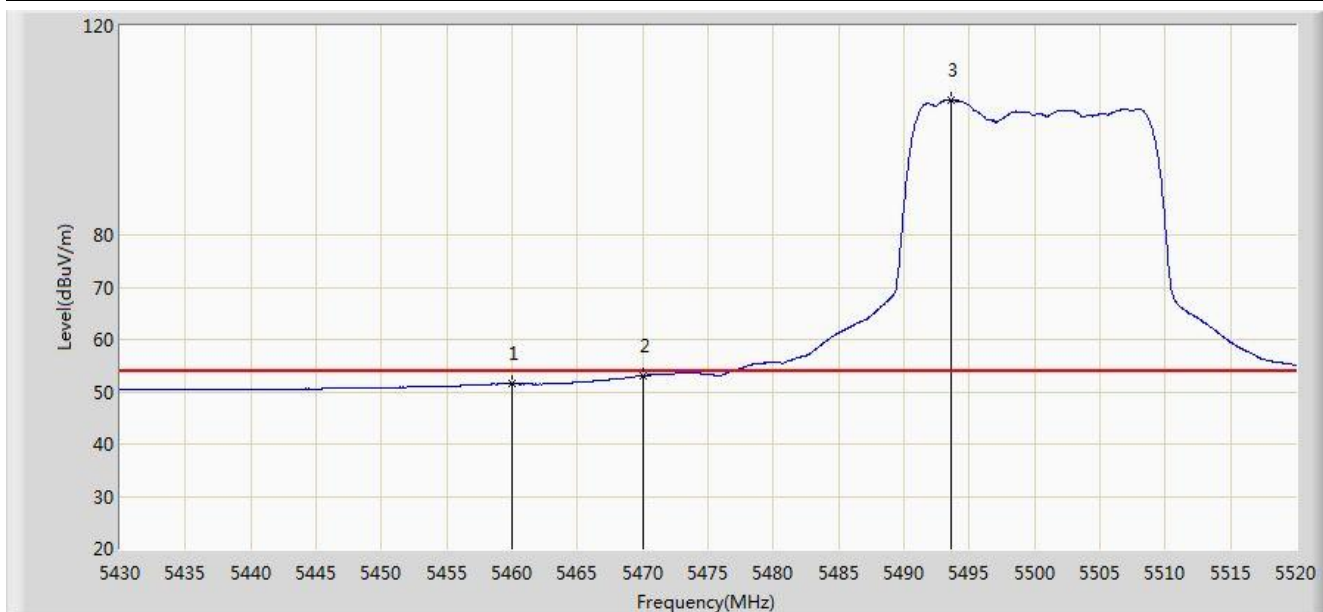

No	Flag	Mark	Frequency (MHz)	Measure Level (dBuV/m)	Reading Level (dBuV)	Over Limit (dB)	Limit (dBuV/m)	Factor (dB)	Type
1			5460.000	51.582	14.772	-2.418	54.000	36.810	AV
2			5470.000	53.174	16.349	-0.826	54.000	36.825	AV
3		*	5493.630	105.764	68.901	N/A	N/A	36.863	AV

Note: Measure Level (dB μ V/m) = Reading Level (dB μ V) + Factor (dB)

Factor (dB) = Cable Loss (dB) + Antenna Factor (dB/m).

Engineer: Roy Cheng	
Site: AC1	Time: 2014/07/15 - 22:24
Limit: FCC_Part15.209_RE(3m)	Margin: 0
Probe: BBHA9120D_1-18GHz	Polarity: Horizontal
EUT: WIFI dual band 4 GE LAN GPON HGU	Power: AC 120V/60Hz
Note: Mode 3: Transmit by 802.11ac20 at channel 5700MHz Ant 0+1+2+3	

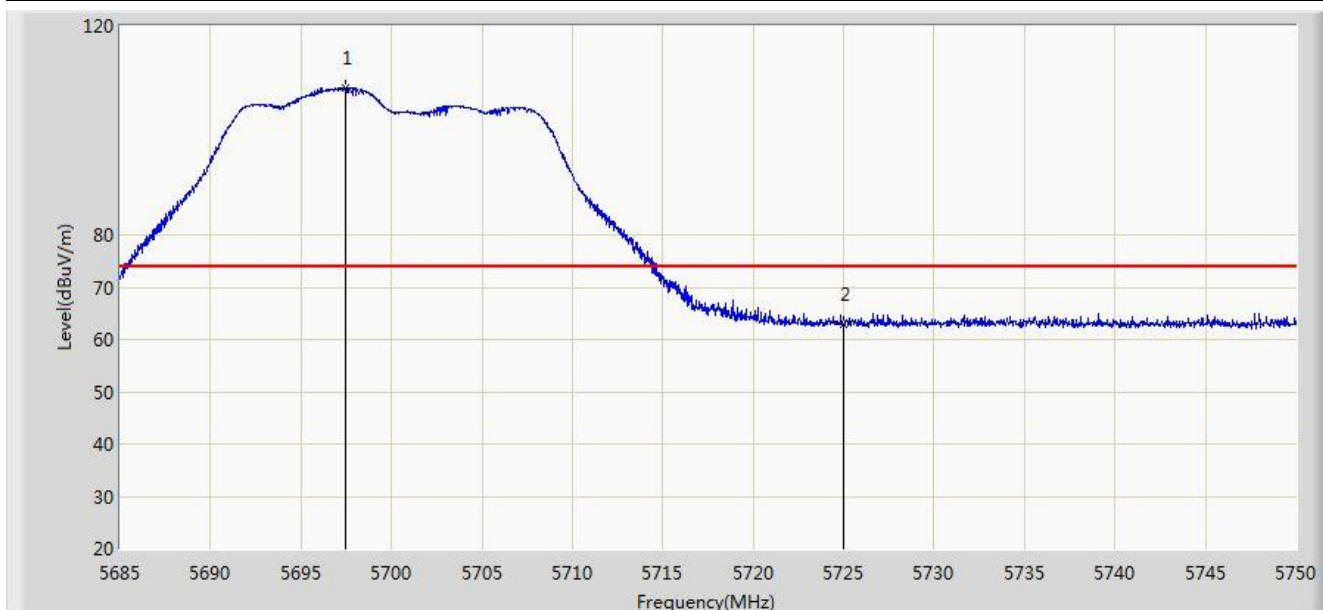

No	Flag	Mark	Frequency (MHz)	Measure Level (dBuV/m)	Reading Level (dBuV)	Over Limit (dB)	Limit (dBuV/m)	Factor (dB)	Type
1		*	5697.447	108.070	70.877	N/A	N/A	37.193	PK
2			5725.000	62.943	25.638	-11.057	74.000	37.305	PK

Note: Measure Level (dB μ V/m) = Reading Level (dB μ V) + Factor (dB)

Factor (dB) = Cable Loss (dB) + Antenna Factor (dB/m).

Engineer: Roy Cheng	
Site: AC1	Time: 2014/07/15 - 22:27
Limit: FCC_Part15.209_RE(3m)	Margin: 0
Probe: BBHA9120D_1-18GHz	Polarity: Horizontal
EUT: WIFI dual band 4 GE LAN GPON HGU	Power: AC 120V/60Hz
Note: Mode 3: Transmit by 802.11ac20 at channel 5700MHz Ant 0+1+2+3	

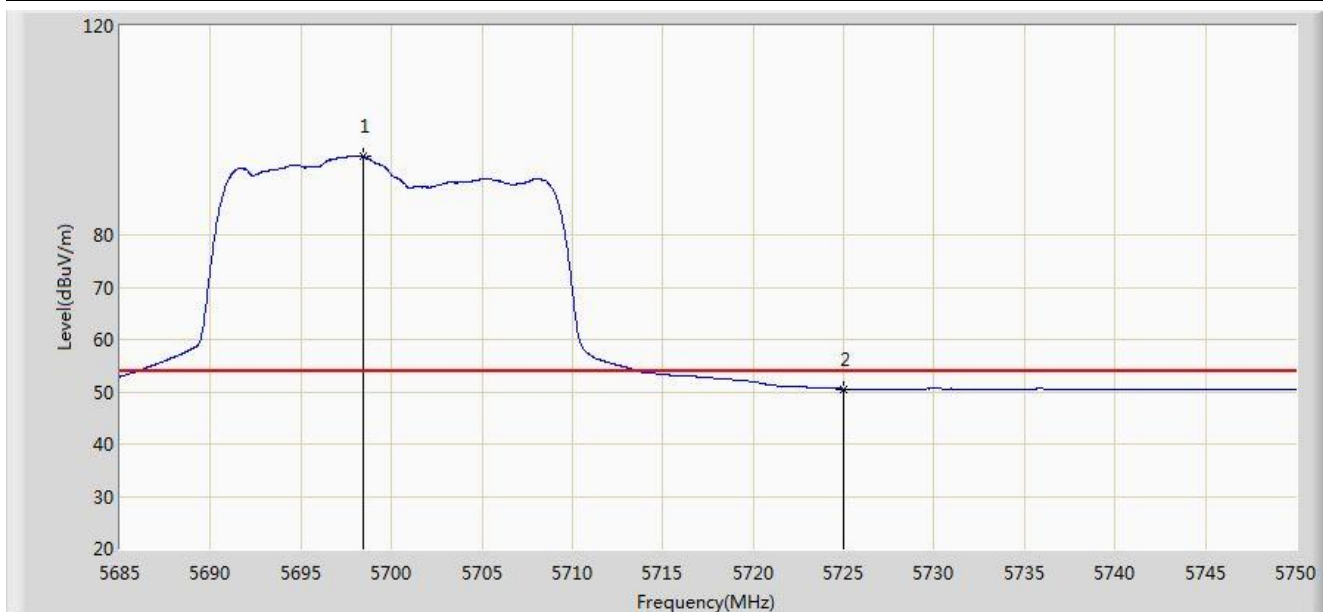

No	Flag	Mark	Frequency (MHz)	Measure Level (dBuV/m)	Reading Level (dBuV)	Over Limit (dB)	Limit (dBuV/m)	Factor (dB)	Type
1		*	5698.422	95.115	57.918	N/A	N/A	37.196	AV
2			5725.000	50.558	13.253	-3.442	54.000	37.305	AV

Note: Measure Level (dB μ V/m) = Reading Level (dB μ V) + Factor (dB)

Factor (dB) = Cable Loss (dB) + Antenna Factor (dB/m).

Engineer: Roy Cheng	
Site: AC1	Time: 2014/07/15 - 22:32
Limit: FCC_Part15.209_RE(3m)	Margin: 0
Probe: BBHA9120D_1-18GHz	Polarity: Vertical
EUT: WIFI dual band 4 GE LAN GPON HGU	Power: AC 120V/60Hz
Note: Mode 3: Transmit by 802.11ac20 at channel 5700MHz Ant 0+1+2+3	

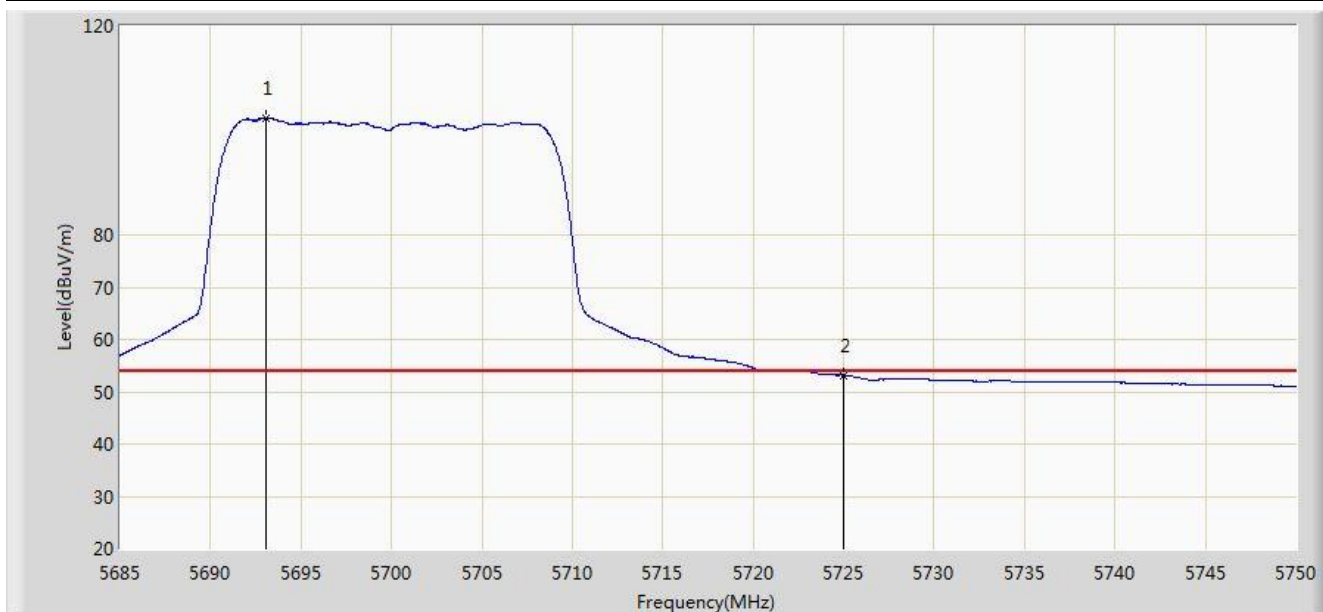

No	Flag	Mark	Frequency (MHz)	Measure Level (dBuV/m)	Reading Level (dBuV)	Over Limit (dB)	Limit (dBuV/m)	Factor (dB)	Type
1		*	5693.060	102.354	65.176	N/A	N/A	37.179	AV
2			5725.000	53.179	15.874	-0.821	54.000	37.305	AV

Note: Measure Level (dB μ V/m) = Reading Level (dB μ V) + Factor (dB)

Factor (dB) = Cable Loss (dB) + Antenna Factor (dB/m).

Engineer: Roy Cheng	
Site: AC1	Time: 2014/07/15 - 22:36
Limit: FCC_Part15.209_RE(3m)	Margin: 0
Probe: BBHA9120D_1-18GHz	Polarity: Vertical
EUT: WIFI dual band 4 GE LAN GPON HGU	Power: AC 120V/60Hz
Note: Mode 3: Transmit by 802.11ac20 at channel 5700MHz Ant 0+1+2+3	

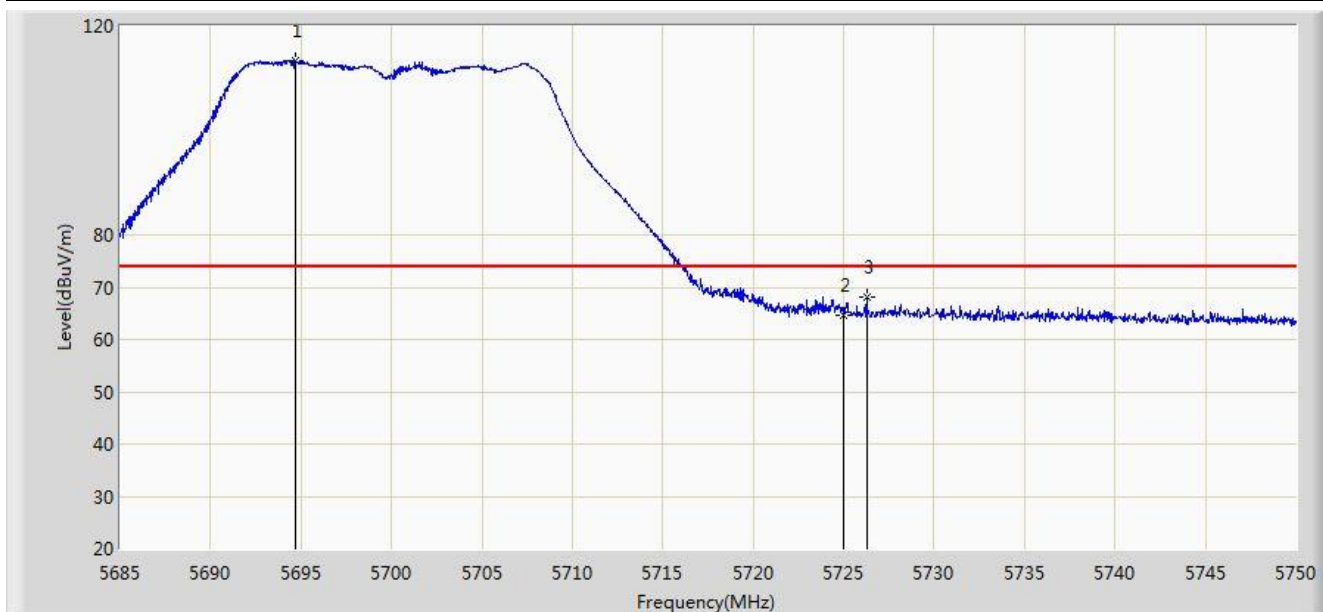

No	Flag	Mark	Frequency (MHz)	Measure Level (dBuV/m)	Reading Level (dBuV)	Over Limit (dB)	Limit (dBuV/m)	Factor (dB)	Type
1		*	5694.685	113.224	76.040	N/A	N/A	37.184	PK
2			5725.000	64.663	27.358	-9.337	74.000	37.305	PK
3			5726.275	68.196	30.886	-5.804	74.000	37.310	PK

Note: Measure Level (dBuV/m) = Reading Level (dBuV) + Factor (dB)

Factor (dB) = Cable Loss (dB) + Antenna Factor (dB/m).

Engineer: Roy Cheng	
Site: AC1	Time: 2014/07/15 - 22:38
Limit: FCC_Part15.209_RE(3m)	Margin: 0
Probe: BBHA9120D_1-18GHz	Polarity: Horizontal
EUT: WIFI dual band 4 GE LAN GPON HGU	Power: AC 120V/60Hz
Note: Mode 4: Transmit by 802.11n40 at channel 5190MHz Ant 0+1+2+3	

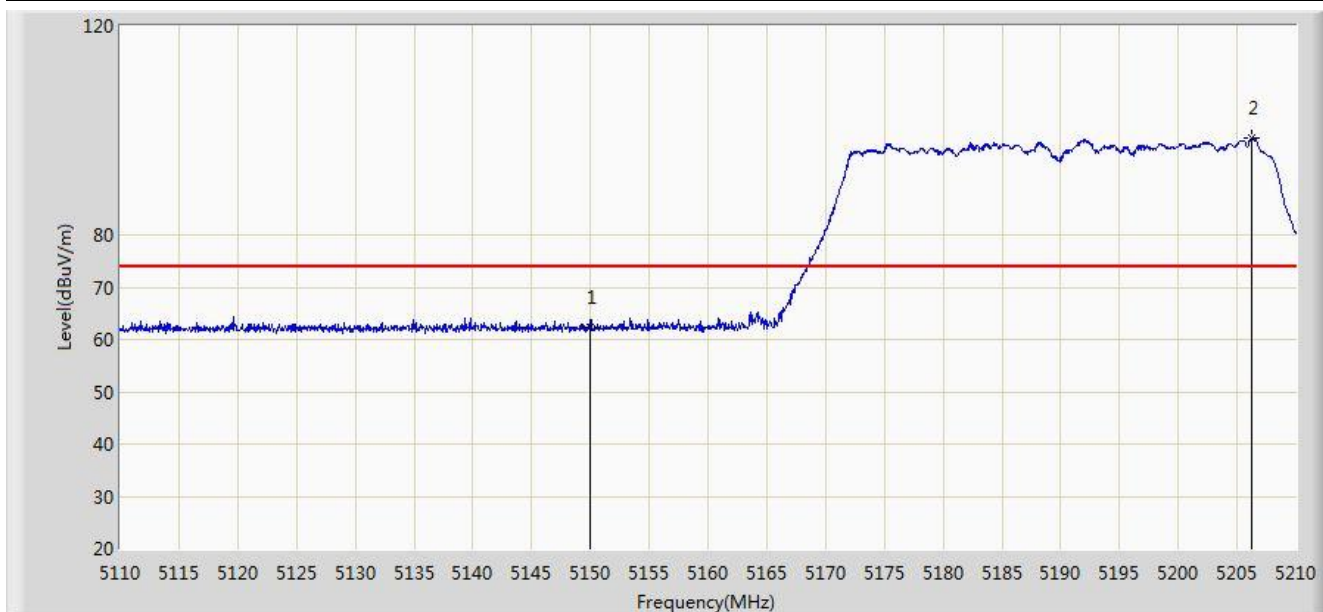

No	Flag	Mark	Frequency (MHz)	Measure Level (dBuV/m)	Reading Level (dBuV)	Over Limit (dB)	Limit (dBuV/m)	Factor (dB)	Type
1			5150.000	62.304	25.552	-11.696	74.000	36.752	PK
2		*	5206.250	98.458	61.858	N/A	N/A	36.600	PK

Note: Measure Level (dB μ V/m) = Reading Level (dB μ V) + Factor (dB)

Factor (dB) = Cable Loss (dB) + Antenna Factor (dB/m).

Engineer: Roy Cheng	
Site: AC1	Time: 2014/07/15 - 22:49
Limit: FCC_Part15.209_RE(3m)	Margin: 0
Probe: BBHA9120D_1-18GHz	Polarity: Horizontal
EUT: WIFI dual band 4 GE LAN GPON HGU	Power: AC 120V/60Hz
Note: Mode 4: Transmit by 802.11n40 at channel 5190MHz Ant 0+1+2+3	

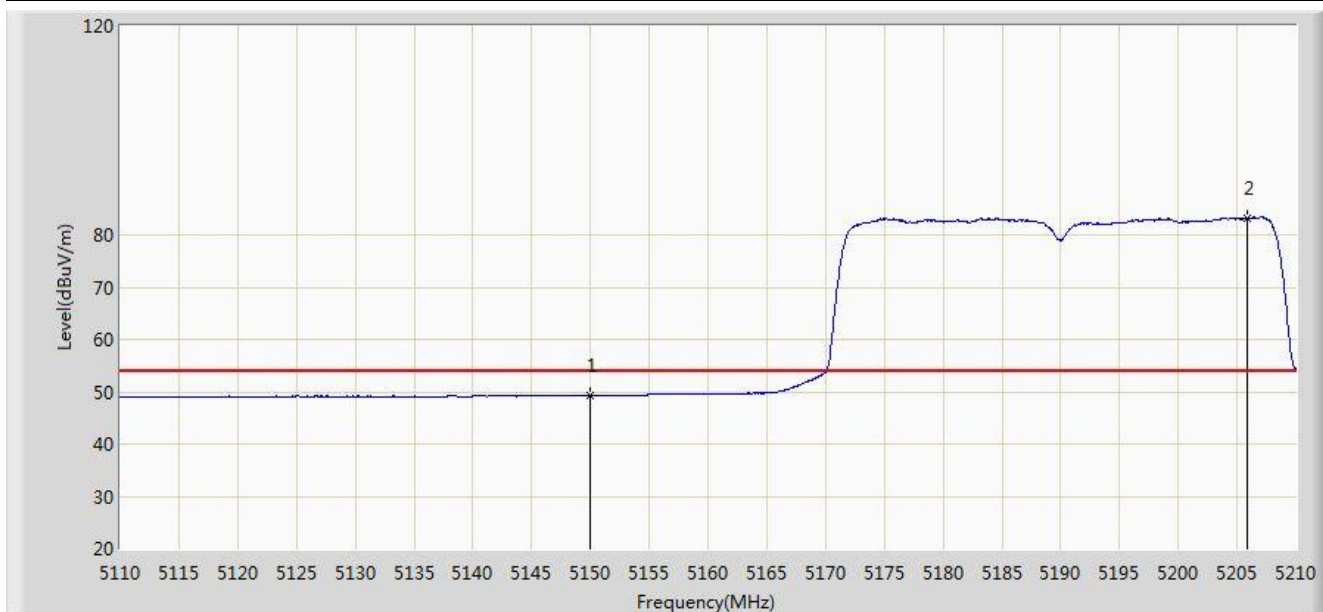

No	Flag	Mark	Frequency (MHz)	Measure Level (dBuV/m)	Reading Level (dBuV)	Over Limit (dB)	Limit (dBuV/m)	Factor (dB)	Type
1			5150.000	49.335	12.583	-4.665	54.000	36.752	AV
2		*	5205.900	83.208	46.607	N/A	N/A	36.601	AV

Note: Measure Level (dB μ V/m) = Reading Level (dB μ V) + Factor (dB)

Factor (dB) = Cable Loss (dB) + Antenna Factor (dB/m).

Engineer: Roy Cheng	
Site: AC1	Time: 2014/07/15 - 22:49
Limit: FCC_Part15.209_RE(3m)	Margin: 0
Probe: BBHA9120D_1-18GHz	Polarity: Vertical
EUT: WIFI dual band 4 GE LAN GPON HGU	Power: AC 120V/60Hz
Note: Mode 4: Transmit by 802.11n40 at channel 5190MHz Ant 0+1+2+3	

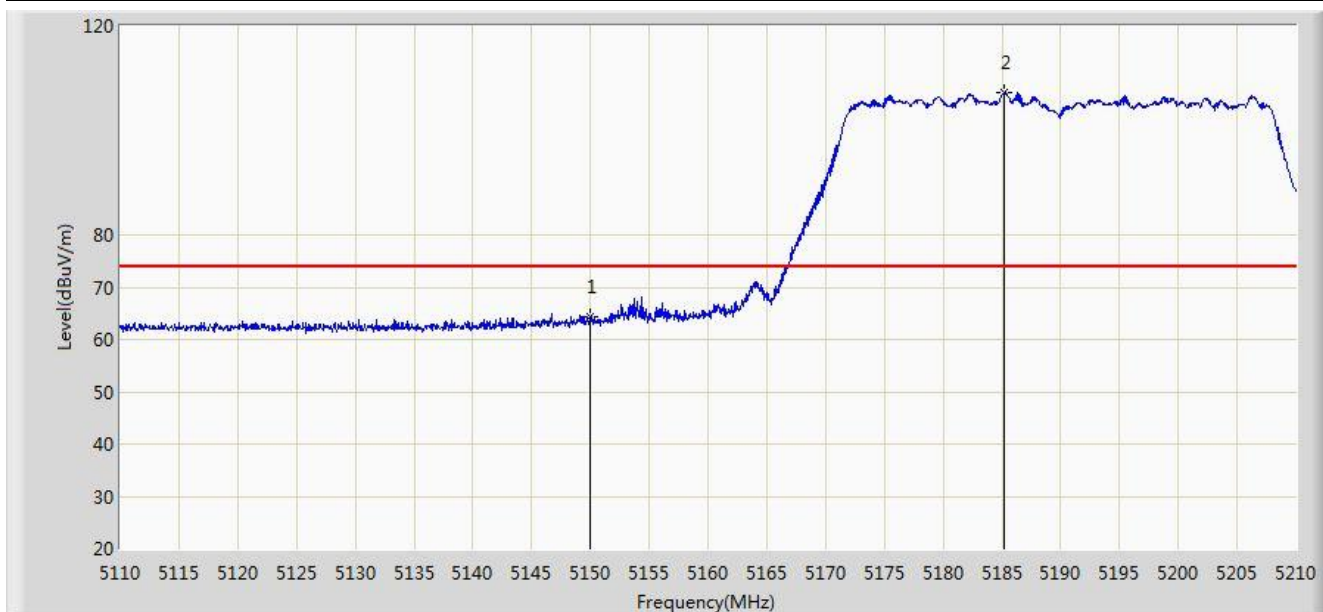

No	Flag	Mark	Frequency (MHz)	Measure Level (dBuV/m)	Reading Level (dBuV)	Over Limit (dB)	Limit (dBuV/m)	Factor (dB)	Type
1			5150.000	64.219	27.467	-9.781	74.000	36.752	PK
2		*	5185.150	107.177	70.526	N/A	N/A	36.650	PK

Note: Measure Level (dB μ V/m) = Reading Level (dB μ V) + Factor (dB)

Factor (dB) = Cable Loss (dB) + Antenna Factor (dB/m).

Engineer: Roy Cheng	
Site: AC1	Time: 2014/07/15 - 22:51
Limit: FCC_Part15.209_RE(3m)	Margin: 0
Probe: BBHA9120D_1-18GHz	Polarity: Vertical
EUT: WIFI dual band 4 GE LAN GPON HGU	Power: AC 120V/60Hz
Note: Mode 4: Transmit by 802.11n40 at channel 5190MHz Ant 0+1+2+3	

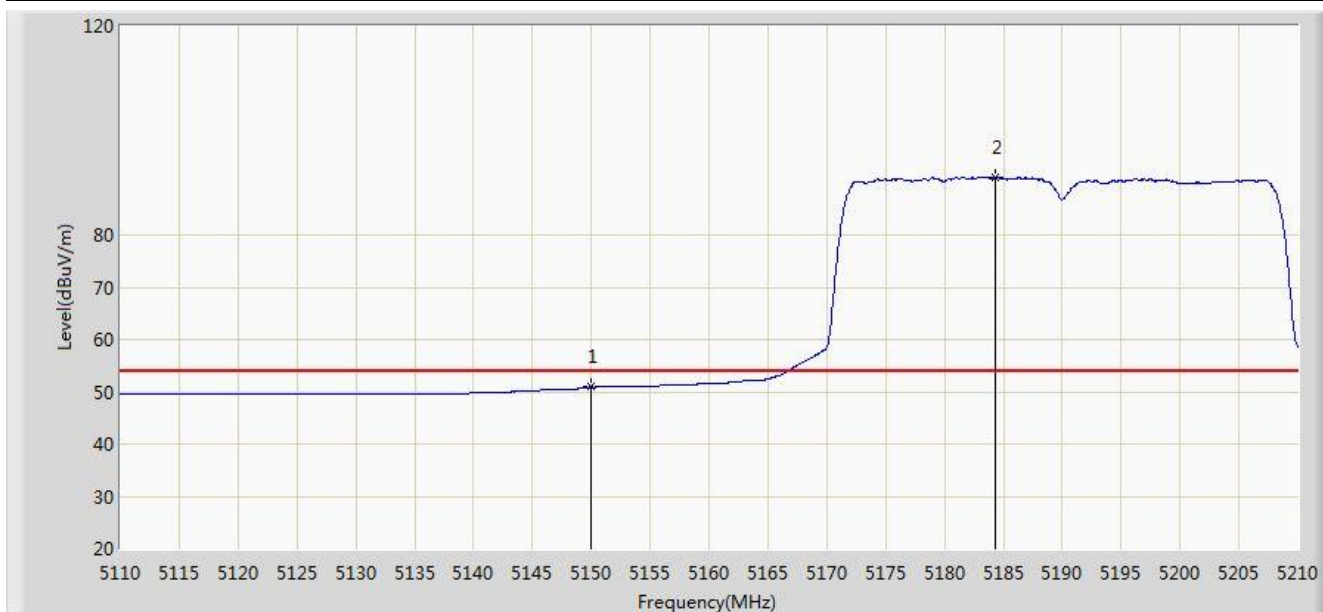

No	Flag	Mark	Frequency (MHz)	Measure Level (dBuV/m)	Reading Level (dBuV)	Over Limit (dB)	Limit (dBuV/m)	Factor (dB)	Type
1			5150.000	50.895	14.143	-3.105	54.000	36.752	AV
2		*	5184.300	91.081	54.428	N/A	N/A	36.653	AV

Note: Measure Level (dB μ V/m) = Reading Level (dB μ V) + Factor (dB)

Factor (dB) = Cable Loss (dB) + Antenna Factor (dB/m).

Engineer: Roy Cheng	
Site: AC1	Time: 2014/07/16 - 09:12
Limit: FCC_Part15.209_RE(3m)	Margin: 0
Probe: BBHA9120D_1-18GHz	Polarity: Horizontal
EUT: WIFI dual band 4 GE LAN GPON HGU	Power: AC 120V/60Hz
Note: Mode 4: Transmit by 802.11n40 at channel 5310MHz Ant 0+1+2+3	

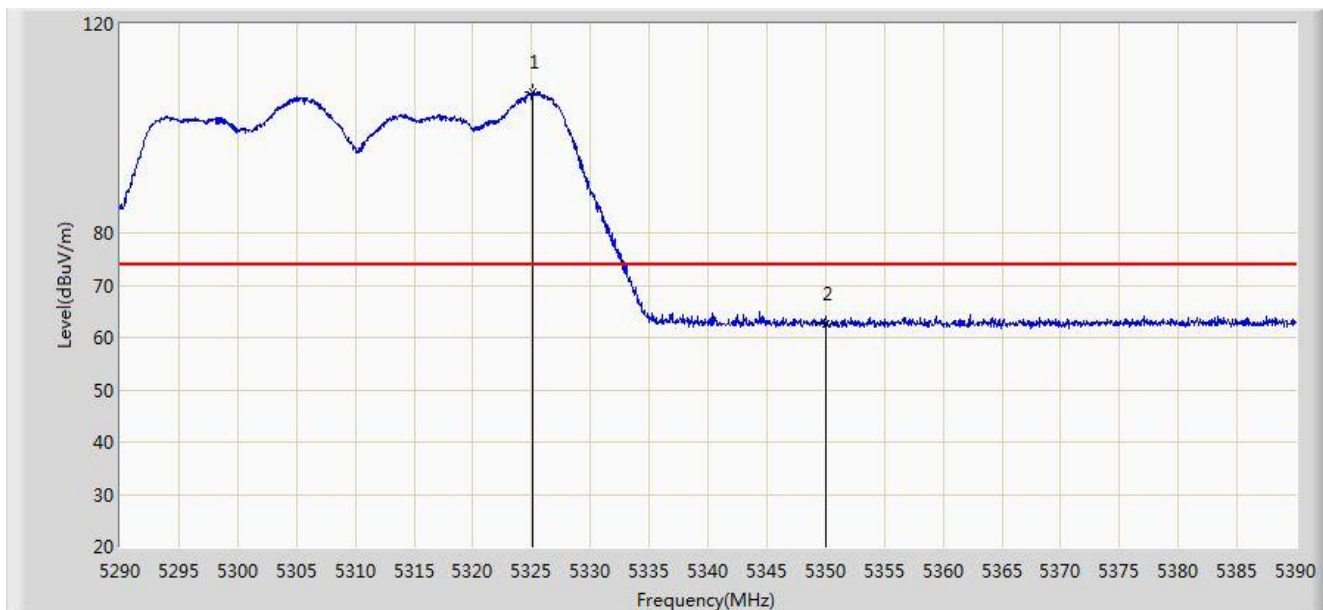

No	Flag	Mark	Frequency (MHz)	Measure Level (dBuV/m)	Reading Level (dBuV)	Over Limit (dB)	Limit (dBuV/m)	Factor (dB)	Type
1		*	5325.100	106.880	70.397	N/A	N/A	36.483	PK
2			5350.000	62.692	26.156	-11.308	74.000	36.536	PK

Note: Measure Level (dB μ V/m) = Reading Level (dB μ V) + Factor (dB)

Factor (dB) = Cable Loss (dB) + Antenna Factor (dB/m).

Engineer: Roy Cheng	
Site: AC1	Time: 2014/07/16 - 09:16
Limit: FCC_Part15.209_RE(3m)	Margin: 0
Probe: BBHA9120D_1-18GHz	Polarity: Horizontal
EUT: WIFI dual band 4 GE LAN GPON HGU	Power: AC 120V/60Hz
Note: Mode 4: Transmit by 802.11n40 at channel 5310MHz Ant 0+1+2+3	

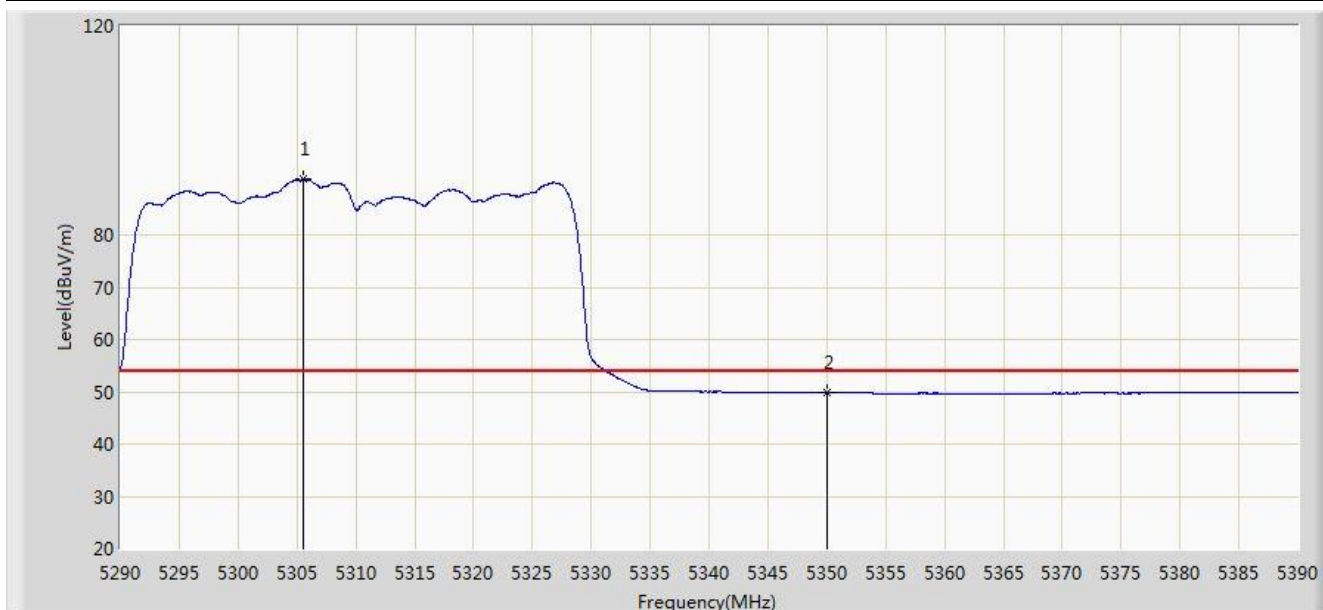

No	Flag	Mark	Frequency (MHz)	Measure Level (dBuV/m)	Reading Level (dBuV)	Over Limit (dB)	Limit (dBuV/m)	Factor (dB)	Type
1		*	5305.550	90.686	54.243	N/A	N/A	36.443	AV
2			5350.000	49.790	13.254	-4.210	54.000	36.536	AV

Note: Measure Level (dB μ V/m) = Reading Level (dB μ V) + Factor (dB)

Factor (dB) = Cable Loss (dB) + Antenna Factor (dB/m).

Engineer: Roy Cheng	
Site: AC1	Time: 2014/07/16 - 09:19
Limit: FCC_Part15.209_RE(3m)	Margin: 0
Probe: BBHA9120D_1-18GHz	Polarity: Vertical
EUT: WIFI dual band 4 GE LAN GPON HGU	Power: AC 120V/60Hz
Note: Mode 4: Transmit by 802.11n40 at channel 5310MHz Ant 0+1+2+3	

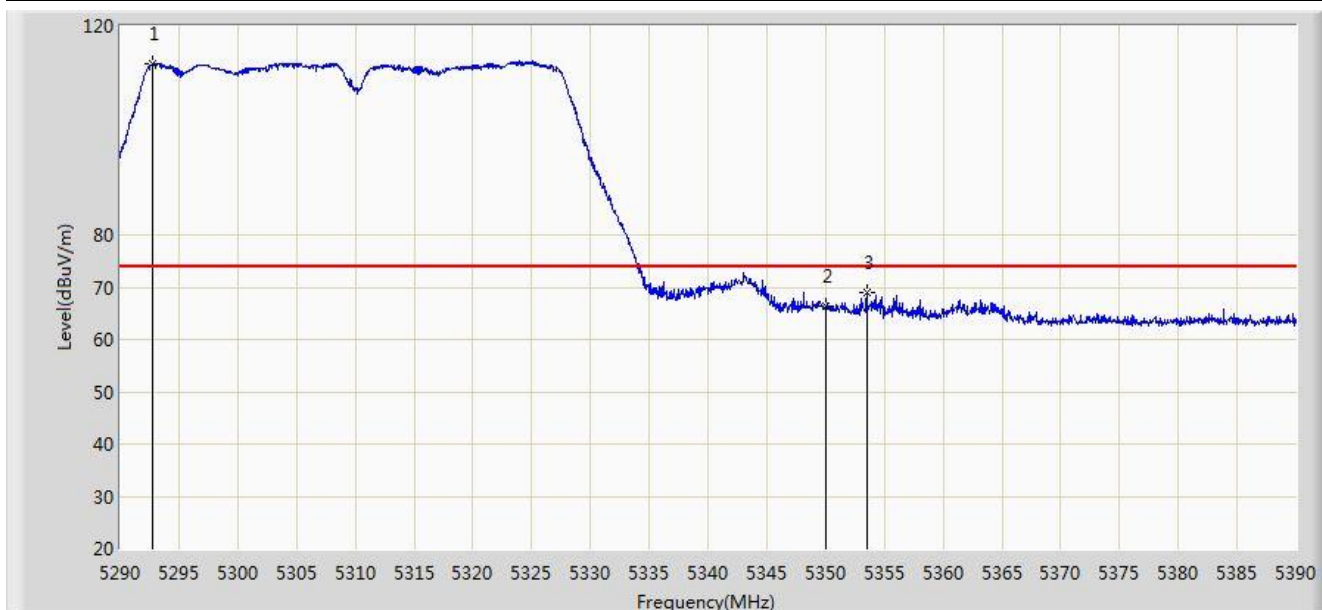

No	Flag	Mark	Frequency (MHz)	Measure Level (dBuV/m)	Reading Level (dBuV)	Over Limit (dB)	Limit (dBuV/m)	Factor (dB)	Type
1		*	5292.800	112.755	76.326	N/A	N/A	36.429	PK
2			5350.000	66.478	29.942	-7.522	74.000	36.536	PK
3			5353.500	68.926	32.382	-5.074	74.000	36.544	PK

Note: Measure Level (dBuV/m) = Reading Level (dBuV) + Factor (dB)

Factor (dB) = Cable Loss (dB) + Antenna Factor (dB/m).

Engineer: Roy Cheng	
Site: AC1	Time: 2014/07/16 - 09:21
Limit: FCC_Part15.209_RE(3m)	Margin: 0
Probe: BBHA9120D_1-18GHz	Polarity: Vertical
EUT: WIFI dual band 4 GE LAN GPON HGU	Power: AC 120V/60Hz
Note: Mode 4: Transmit by 802.11n40 at channel 5310MHz Ant 0+1+2+3	

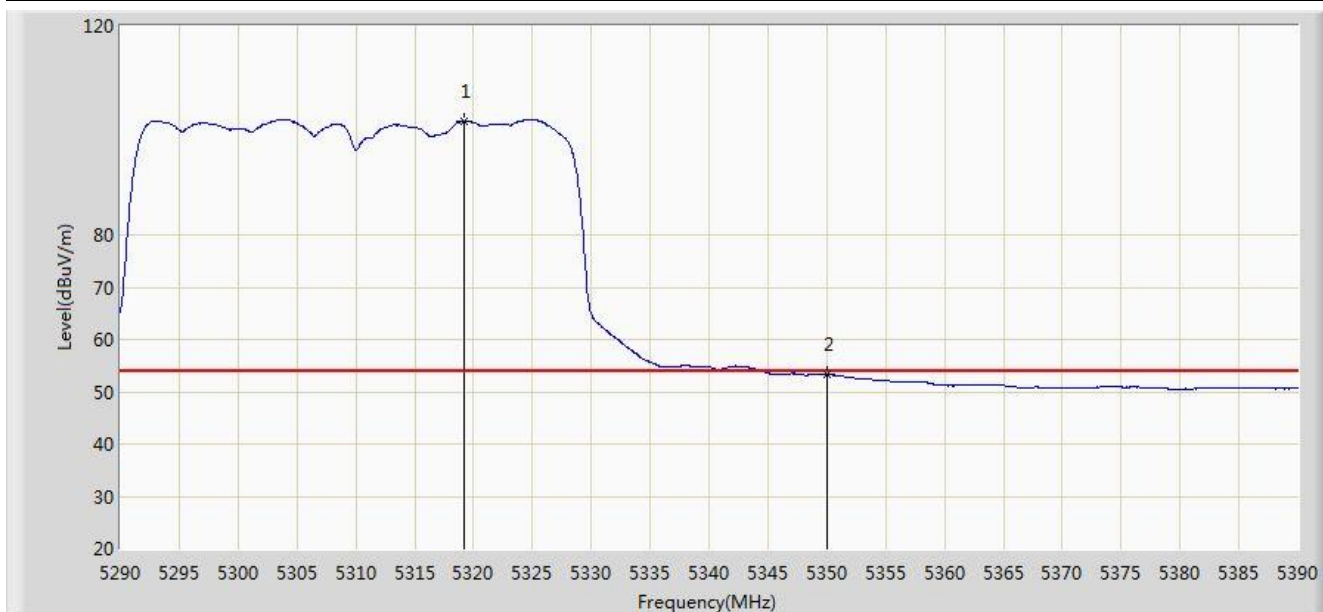

No	Flag	Mark	Frequency (MHz)	Measure Level (dBuV/m)	Reading Level (dBuV)	Over Limit (dB)	Limit (dBuV/m)	Factor (dB)	Type
1		*	5319.200	101.867	65.397	N/A	N/A	36.469	AV
2			5350.000	53.237	16.701	-0.763	54.000	36.536	AV

Note: Measure Level (dB μ V/m) = Reading Level (dB μ V) + Factor (dB)

Factor (dB) = Cable Loss (dB) + Antenna Factor (dB/m).

Engineer: Roy Cheng	
Site: AC1	Time: 2014/07/16 - 09:25
Limit: FCC_Part15.209_RE(3m)	Margin: 0
Probe: BBHA9120D_1-18GHz	Polarity: Horizontal
EUT: WIFI dual band 4 GE LAN GPON HGU	Power: AC 120V/60Hz
Note: Mode 4: Transmit by 802.11n40 at channel 5510MHz Ant 0+1+2+3	

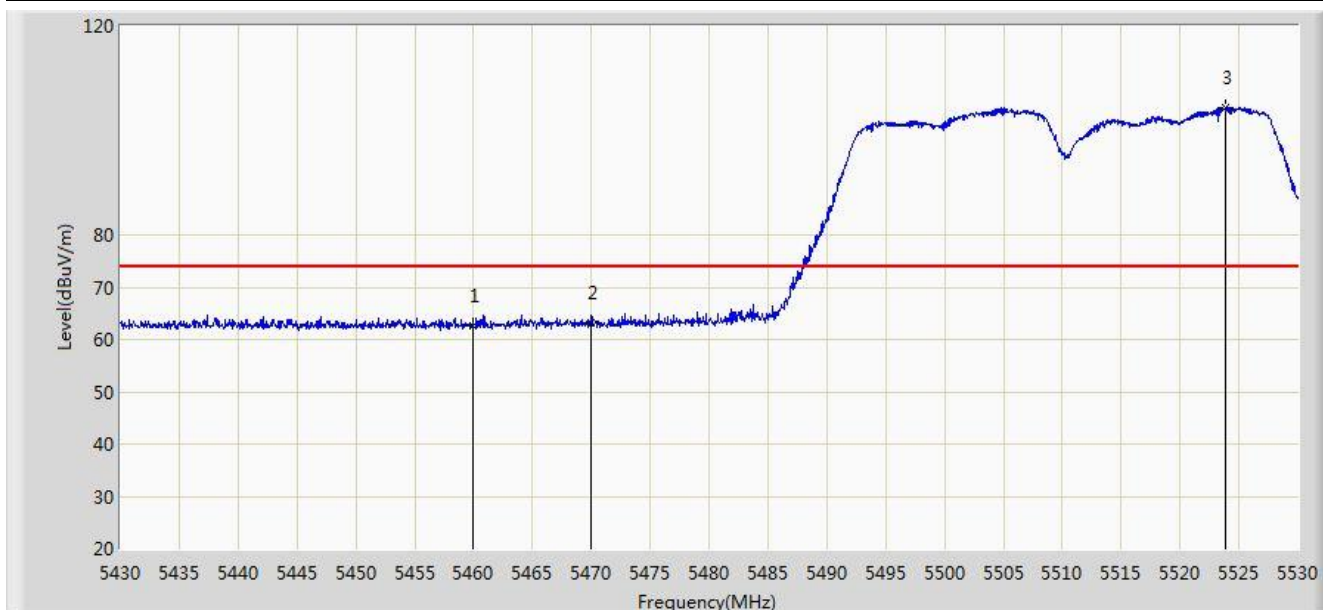

No	Flag	Mark	Frequency (MHz)	Measure Level (dBuV/m)	Reading Level (dBuV)	Over Limit (dB)	Limit (dBuV/m)	Factor (dB)	Type
1			5460.000	62.748	25.938	-11.252	74.000	36.810	PK
2			5470.000	63.125	26.300	-10.875	74.000	36.825	PK
3		*	5523.850	104.325	67.402	N/A	N/A	36.923	PK

Note: Measure Level (dBuV/m) = Reading Level (dBuV) + Factor (dB)

Factor (dB) = Cable Loss (dB) + Antenna Factor (dB/m).

Engineer: Roy Cheng	
Site: AC1	Time: 2014/07/16 - 09:27
Limit: FCC_Part15.209_RE(3m)	Margin: 0
Probe: BBHA9120D_1-18GHz	Polarity: Horizontal
EUT: WIFI dual band 4 GE LAN GPON HGU	Power: AC 120V/60Hz
Note: Mode 4: Transmit by 802.11n40 at channel 5510MHz Ant 0+1+2+3	

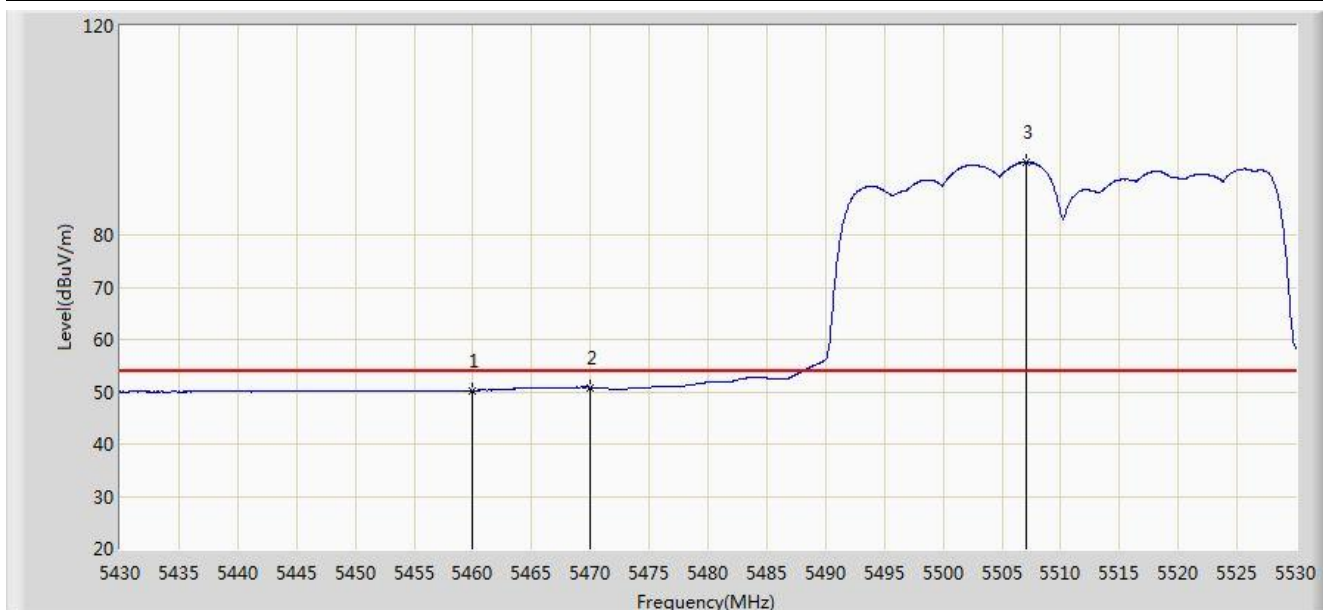

No	Flag	Mark	Frequency (MHz)	Measure Level (dBuV/m)	Reading Level (dBuV)	Over Limit (dB)	Limit (dBuV/m)	Factor (dB)	Type
1			5460.000	50.221	13.411	-3.779	54.000	36.810	AV
2			5470.000	50.834	14.009	-3.166	54.000	36.825	AV
3		*	5507.100	93.863	56.975	N/A	N/A	36.888	AV

Note: Measure Level (dB μ V/m) = Reading Level (dB μ V) + Factor (dB)

Factor (dB) = Cable Loss (dB) + Antenna Factor (dB/m).

Engineer: Roy Cheng	
Site: AC1	Time: 2014/07/16 - 09:31
Limit: FCC_Part15.209_RE(3m)	Margin: 0
Probe: BBHA9120D_1-18GHz	Polarity: Vertical
EUT: WIFI dual band 4 GE LAN GPON HGU	Power: AC 120V/60Hz
Note: Mode 4: Transmit by 802.11n40 at channel 5510MHz Ant 0+1+2+3	

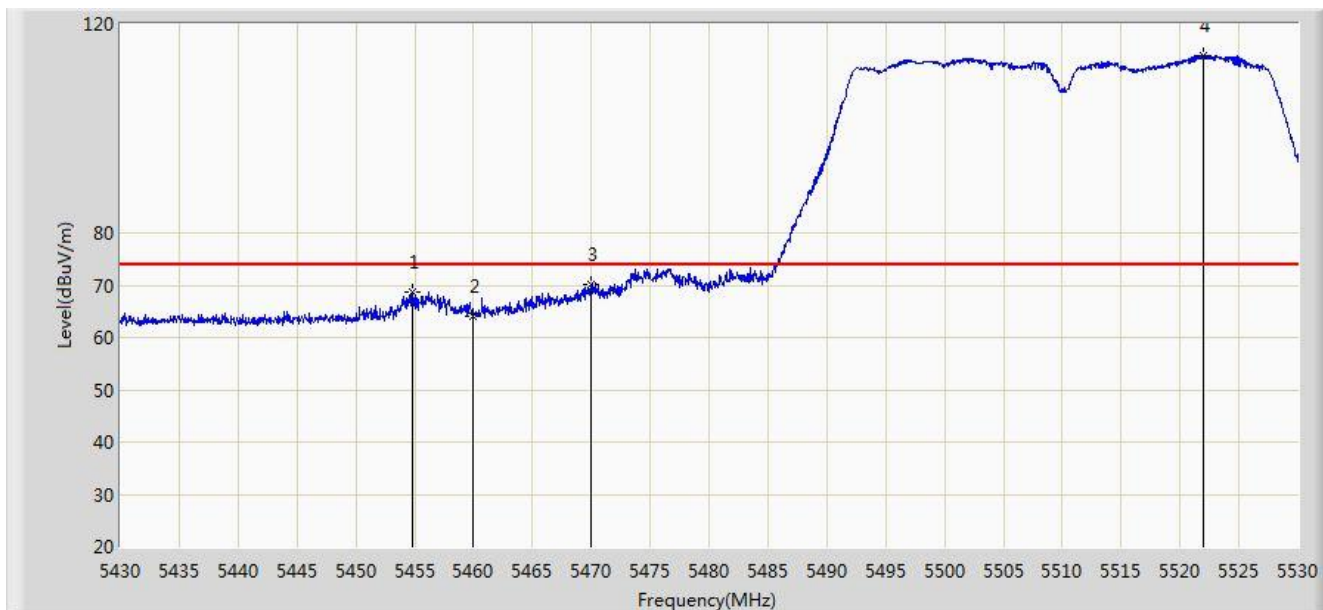

No	Flag	Mark	Frequency (MHz)	Measure Level (dBuV/m)	Reading Level (dBuV)	Over Limit (dB)	Limit (dBuV/m)	Factor (dB)	Type
1			5454.750	68.730	31.928	-5.270	74.000	36.801	PK
2			5460.000	64.052	27.242	-9.948	74.000	36.810	PK
3			5470.000	70.140	33.315	-3.860	74.000	36.825	PK
4		*	5522.000	114.006	77.085	N/A	N/A	36.921	PK

Note: Measure Level (dBuV/m) = Reading Level (dBuV) + Factor (dB)

Factor (dB) = Cable Loss (dB) + Antenna Factor (dB/m).

Engineer: Roy Cheng	
Site: AC1	Time: 2014/07/16 - 09:33
Limit: FCC_Part15.209_RE(3m)	Margin: 0
Probe: BBHA9120D_1-18GHz	Polarity: Vertical
EUT: WIFI dual band 4 GE LAN GPON HGU	Power: AC 120V/60Hz
Note: Mode 4: Transmit by 802.11n40 at channel 5510MHz Ant 0+1+2+3	

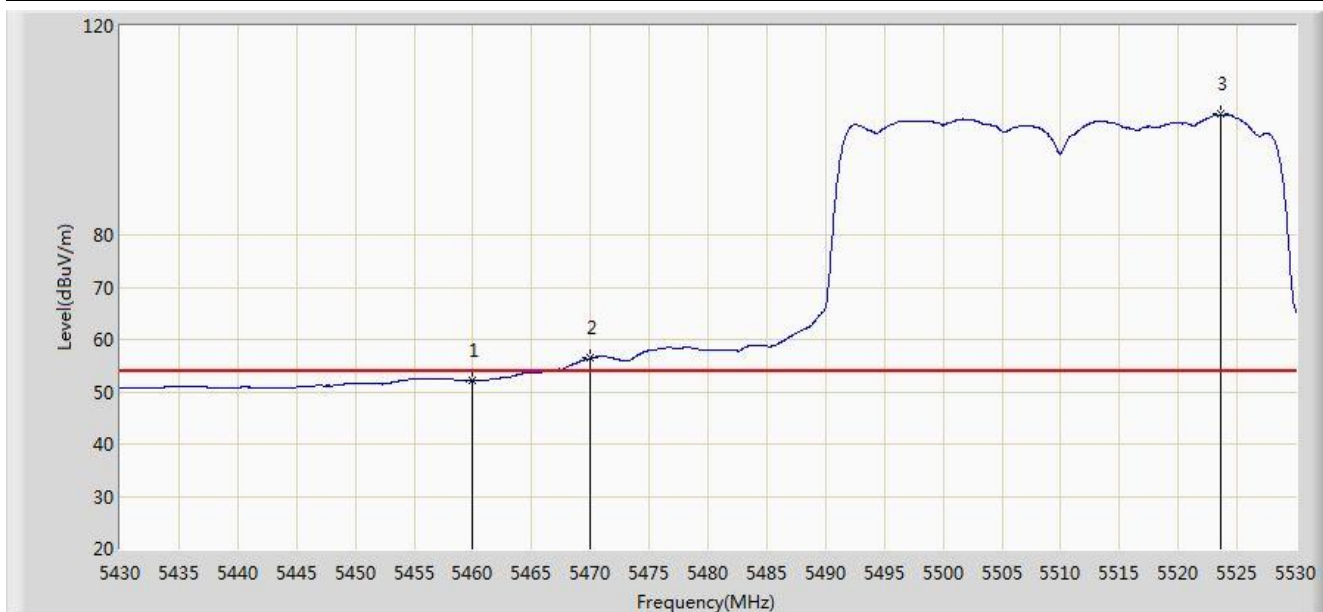

No	Flag	Mark	Frequency (MHz)	Measure Level (dBuV/m)	Reading Level (dBuV)	Over Limit (dB)	Limit (dBuV/m)	Factor (dB)	Type
1			5460.000	52.156	15.346	-1.844	54.000	36.810	AV
2			5470.000	56.400	19.575	2.400	54.000	36.825	AV
3		*	5523.600	103.079	66.156	N/A	N/A	36.923	AV

Note: Measure Level (dB μ V/m) = Reading Level (dB μ V) + Factor (dB)

Factor (dB) = Cable Loss (dB) + Antenna Factor (dB/m).

Engineer: Roy Cheng	
Site: AC1	Time: 2014/07/16 - 09:56
Limit: FCC_Part15.209_RE(3m)	Margin: 0
Probe: BBHA9120D_1-18GHz	Polarity: Horizontal
EUT: WIFI dual band 4 GE LAN GPON HGU	Power: AC 120V/60Hz
Note: Mode 4: Transmit by 802.11n40 at channel 5670MHz Ant 0+1+2+3	

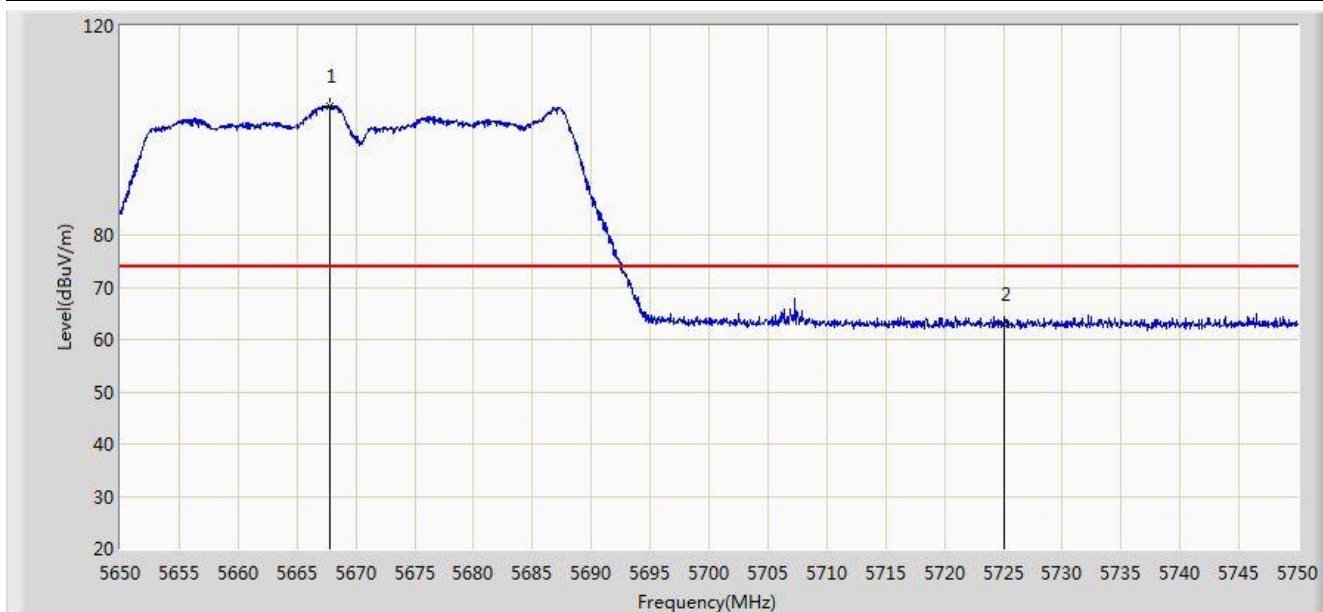

No	Flag	Mark	Frequency (MHz)	Measure Level (dBuV/m)	Reading Level (dBuV)	Over Limit (dB)	Limit (dBuV/m)	Factor (dB)	Type
1		*	5667.750	104.745	67.660	N/A	N/A	37.084	PK
2			5725.000	62.936	25.631	-11.064	74.000	37.305	PK

Note: Measure Level (dB μ V/m) = Reading Level (dB μ V) + Factor (dB)

Factor (dB) = Cable Loss (dB) + Antenna Factor (dB/m).

Engineer: Roy Cheng	
Site: AC1	Time: 2014/07/16 - 10:04
Limit: FCC_Part15.209_RE(3m)	Margin: 0
Probe: BBHA9120D_1-18GHz	Polarity: Horizontal
EUT: WIFI dual band 4 GE LAN GPON HGU	Power: AC 120V/60Hz
Note: Mode 4: Transmit by 802.11n40 at channel 5670MHz Ant 0+1+2+3	

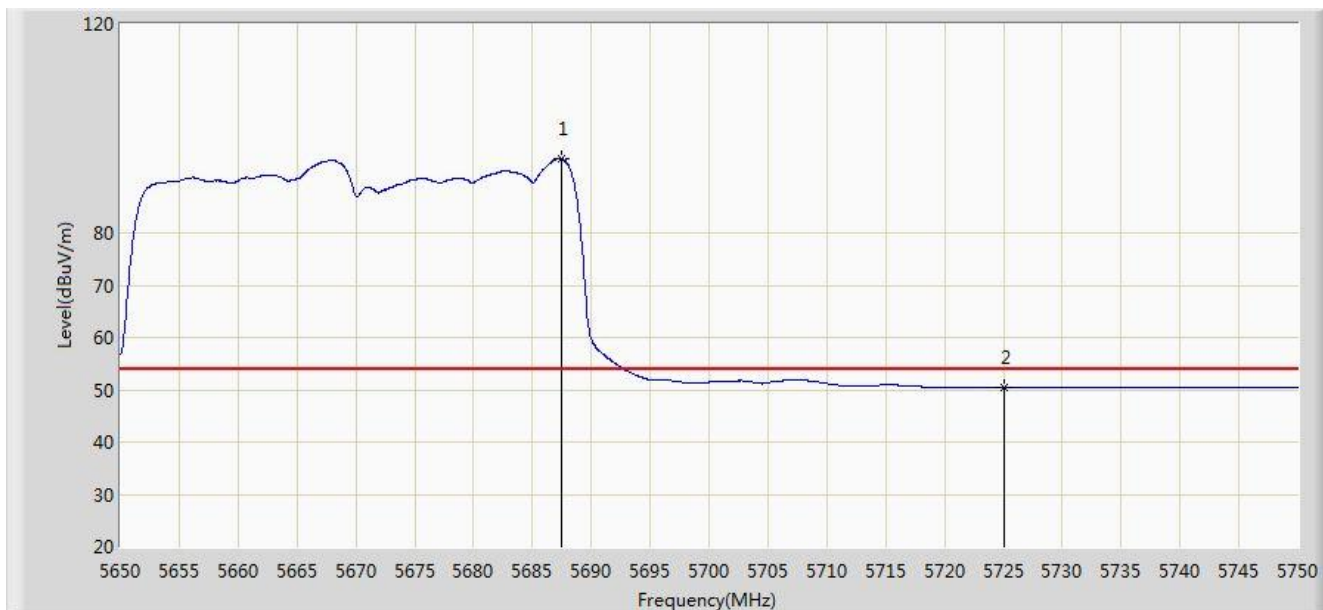

No	Flag	Mark	Frequency (MHz)	Measure Level (dBuV/m)	Reading Level (dBuV)	Over Limit (dB)	Limit (dBuV/m)	Factor (dB)	Type
1		*	5687.450	94.228	57.075	N/A	N/A	37.153	AV
2			5725.000	50.542	13.237	-3.458	54.000	37.305	AV

Note: Measure Level (dB μ V/m) = Reading Level (dB μ V) + Factor (dB)

Factor (dB) = Cable Loss (dB) + Antenna Factor (dB/m).

Engineer: Roy Cheng	
Site: AC1	Time: 2014/07/16 - 10:12
Limit: FCC_Part15.209_RE(3m)	Margin: 0
Probe: BBHA9120D_1-18GHz	Polarity: Vertical
EUT: WIFI dual band 4 GE LAN GPON HGU	Power: AC 120V/60Hz
Note: Mode 4: Transmit by 802.11n40 at channel 5670MHz Ant 0+1+2+3	

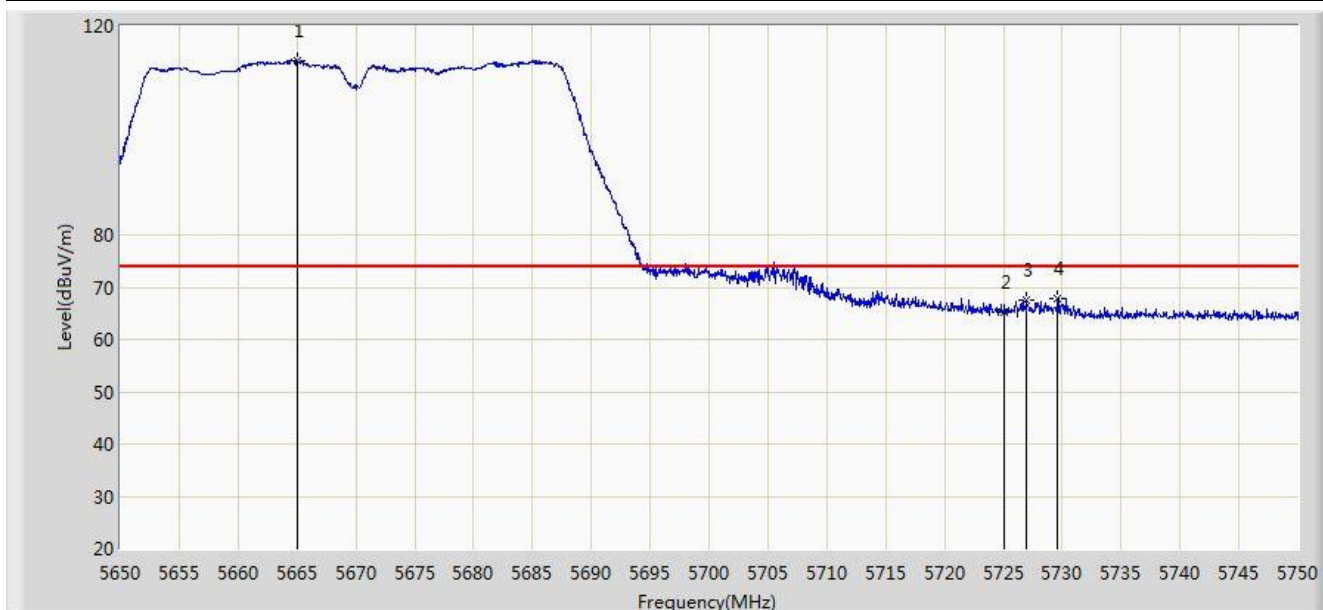

No	Flag	Mark	Frequency (MHz)	Measure Level (dBuV/m)	Reading Level (dBuV)	Over Limit (dB)	Limit (dBuV/m)	Factor (dB)	Type
1		*	5665.050	113.401	76.322	N/A	N/A	37.079	PK
2			5725.000	65.142	27.837	-8.858	74.000	37.305	PK
3			5727.000	67.499	30.186	-6.501	74.000	37.313	PK
4			5729.600	67.756	30.433	-6.244	74.000	37.324	PK

Note: Measure Level (dBuV/m) = Reading Level (dBuV) + Factor (dB)

Factor (dB) = Cable Loss (dB) + Antenna Factor (dB/m).

Engineer: Roy Cheng	
Site: AC1	Time: 2014/07/16 - 10:16
Limit: FCC_Part15.209_RE(3m)	Margin: 0
Probe: BBHA9120D_1-18GHz	Polarity: Vertical
EUT: WIFI dual band 4 GE LAN GPON HGU	Power: AC 120V/60Hz
Note: Mode 4: Transmit by 802.11n40 at channel 5670MHz Ant 0+1+2+3	

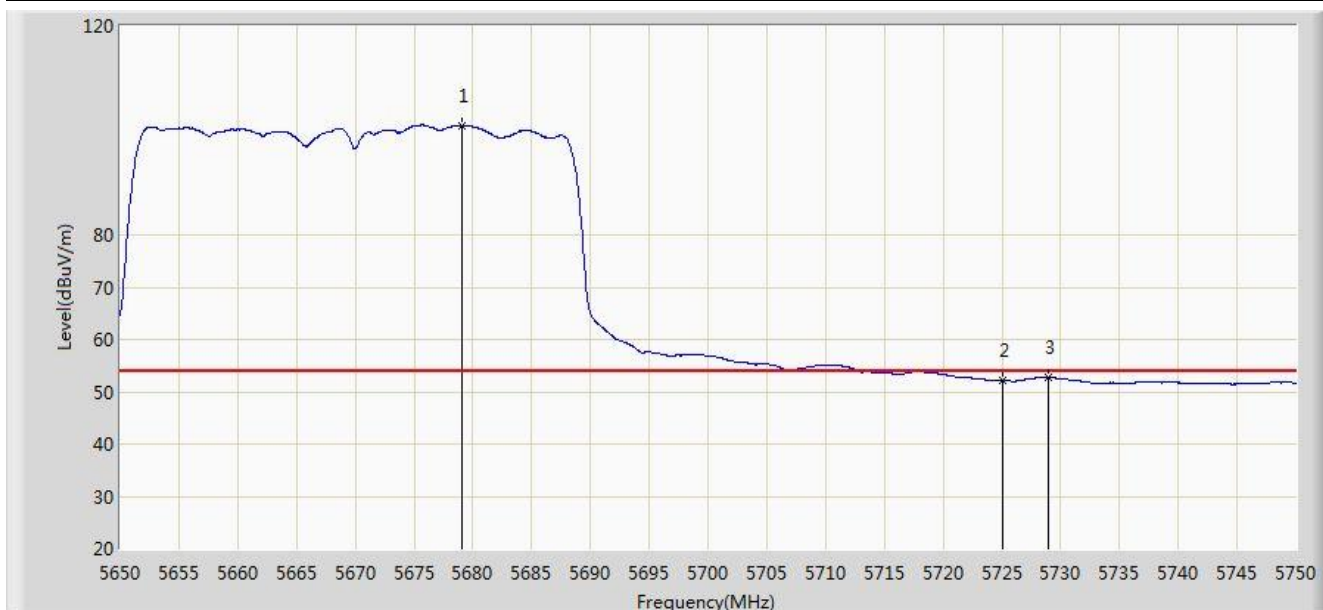

No	Flag	Mark	Frequency (MHz)	Measure Level (dBuV/m)	Reading Level (dBuV)	Over Limit (dB)	Limit (dBuV/m)	Factor (dB)	Type
1		*	5679.050	100.957	63.840	N/A	N/A	37.117	AV
2			5725.000	52.256	14.951	-1.744	54.000	37.305	AV
3			5728.950	52.640	15.319	-1.360	54.000	37.321	AV

Note: Measure Level (dB μ V/m) = Reading Level (dB μ V) + Factor (dB)

Factor (dB) = Cable Loss (dB) + Antenna Factor (dB/m).

Engineer: Roy Cheng	
Site: AC1	Time: 2014/07/18 - 15:04
Limit: FCC_Part15.209_RE(3m)	Margin: 0
Probe: BBHA9120D_1-18GHz	Polarity: Horizontal
EUT: WIFI dual band 4 GE LAN GPON HGU	Power: AC 120V/60Hz
Note: Mode 5: Transmit by 802.11ac40 at channel 5190MHz Ant 0+1+2+3	

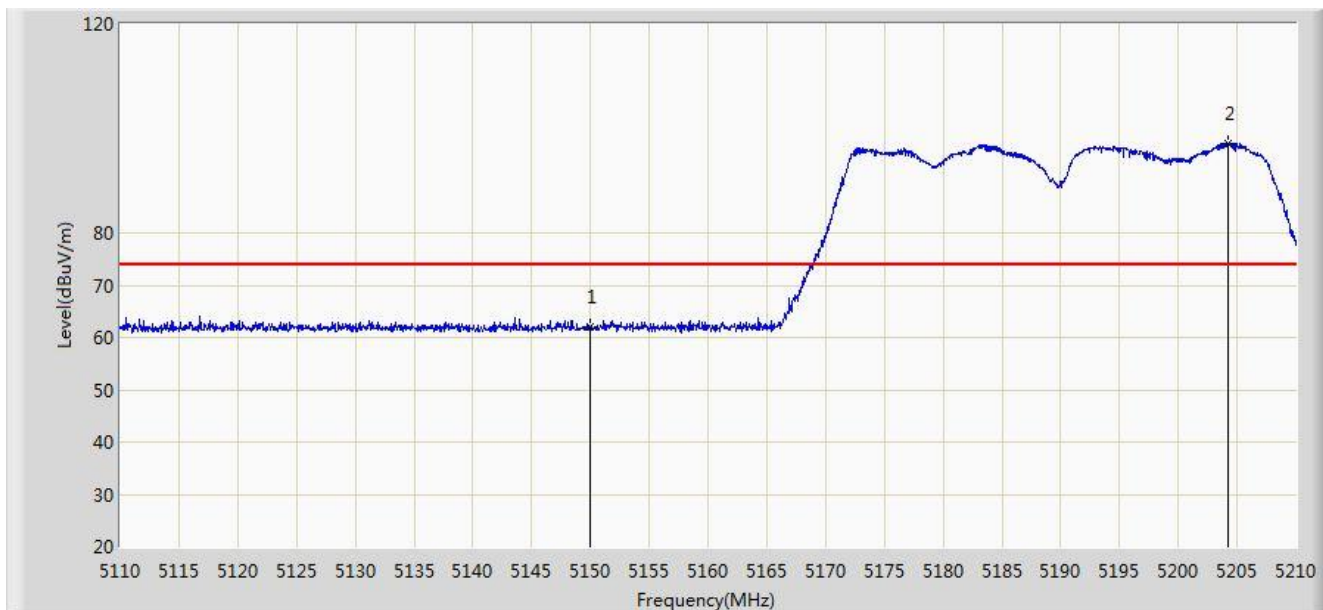

No	Flag	Mark	Frequency (MHz)	Measure Level (dBuV/m)	Reading Level (dBuV)	Over Limit (dB)	Limit (dBuV/m)	Factor (dB)	Type
1			5150.000	61.992	25.240	-12.008	74.000	36.752	PK
2		*	5204.200	97.206	60.602	N/A	N/A	36.604	PK

Note: Measure Level (dB μ V/m) = Reading Level (dB μ V) + Factor (dB)

Factor (dB) = Cable Loss (dB) + Antenna Factor (dB/m).

Engineer: Roy Cheng	
Site: AC1	Time: 2014/07/18 - 15:10
Limit: FCC_Part15.209_RE(3m)	Margin: 0
Probe: BBHA9120D_1-18GHz	Polarity: Horizontal
EUT: WIFI dual band 4 GE LAN GPON HGU	Power: AC 120V/60Hz
Note: Mode 5: Transmit by 802.11ac40 at channel 5190MHz Ant 0+1+2+3	

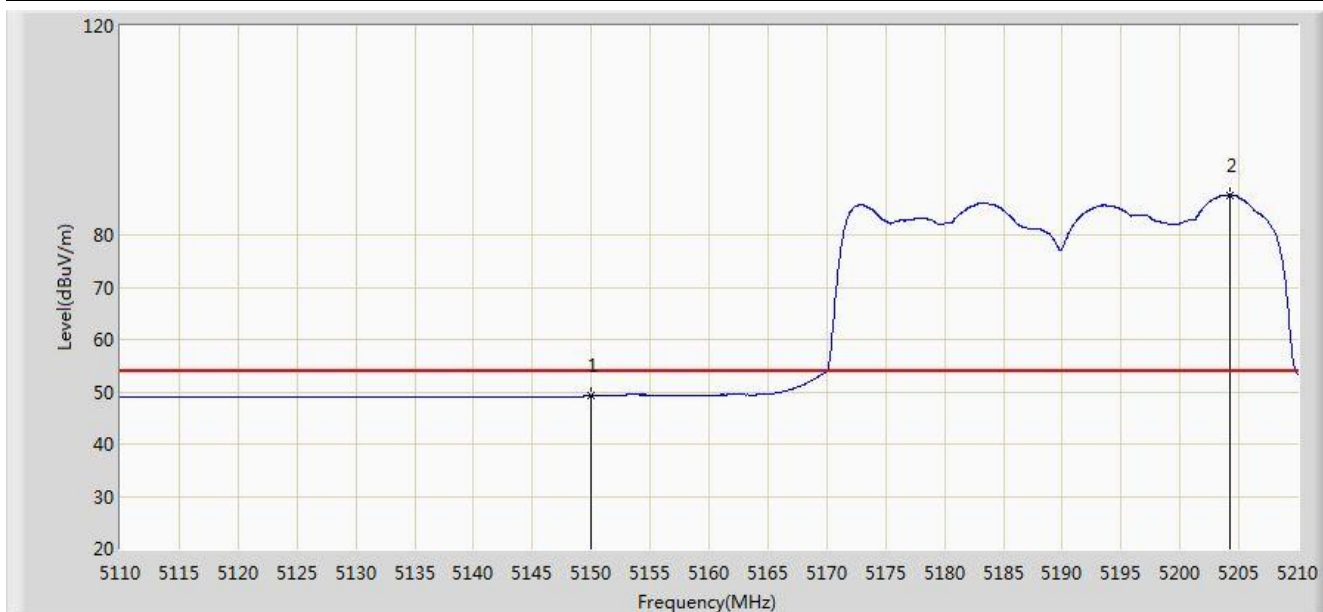

No	Flag	Mark	Frequency (MHz)	Measure Level (dBuV/m)	Reading Level (dBuV)	Over Limit (dB)	Limit (dBuV/m)	Factor (dB)	Type
1			5150.000	49.175	12.423	-4.825	54.000	36.752	AV
2		*	5204.200	87.672	51.068	N/A	N/A	36.604	AV

Note: Measure Level (dB μ V/m) = Reading Level (dB μ V) + Factor (dB)

Factor (dB) = Cable Loss (dB) + Antenna Factor (dB/m).

Engineer: Roy Cheng	
Site: AC1	Time: 2014/07/18 - 15:13
Limit: FCC_Part15.209_RE(3m)	Margin: 0
Probe: BBHA9120D_1-18GHz	Polarity: Vertical
EUT: WIFI dual band 4 GE LAN GPON HGU	Power: AC 120V/60Hz
Note: Mode 5: Transmit by 802.11ac40 at channel 5190MHz Ant 0+1+2+3	

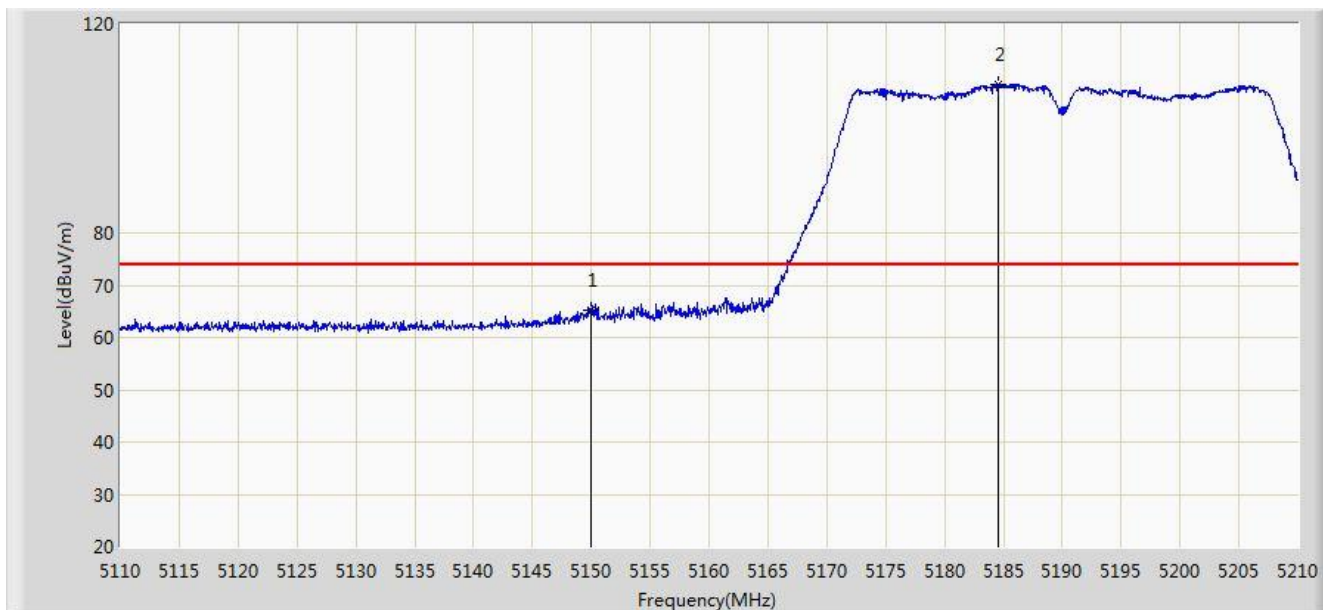

No	Flag	Mark	Frequency (MHz)	Measure Level (dBuV/m)	Reading Level (dBuV)	Over Limit (dB)	Limit (dBuV/m)	Factor (dB)	Type
1			5150.000	65.111	28.359	-8.889	74.000	36.752	PK
2		*	5184.600	108.400	71.748	N/A	N/A	36.652	PK

Note: Measure Level (dB μ V/m) = Reading Level (dB μ V) + Factor (dB)

Factor (dB) = Cable Loss (dB) + Antenna Factor (dB/m).

Engineer: Roy Cheng	
Site: AC1	Time: 2014/07/18 - 15:14
Limit: FCC_Part15.209_RE(3m)	Margin: 0
Probe: BBHA9120D_1-18GHz	Polarity: Vertical
EUT: WIFI dual band 4 GE LAN GPON HGU	Power: AC 120V/60Hz
Note: Mode 5: Transmit by 802.11ac40 at channel 5190MHz Ant 0+1+2+3	

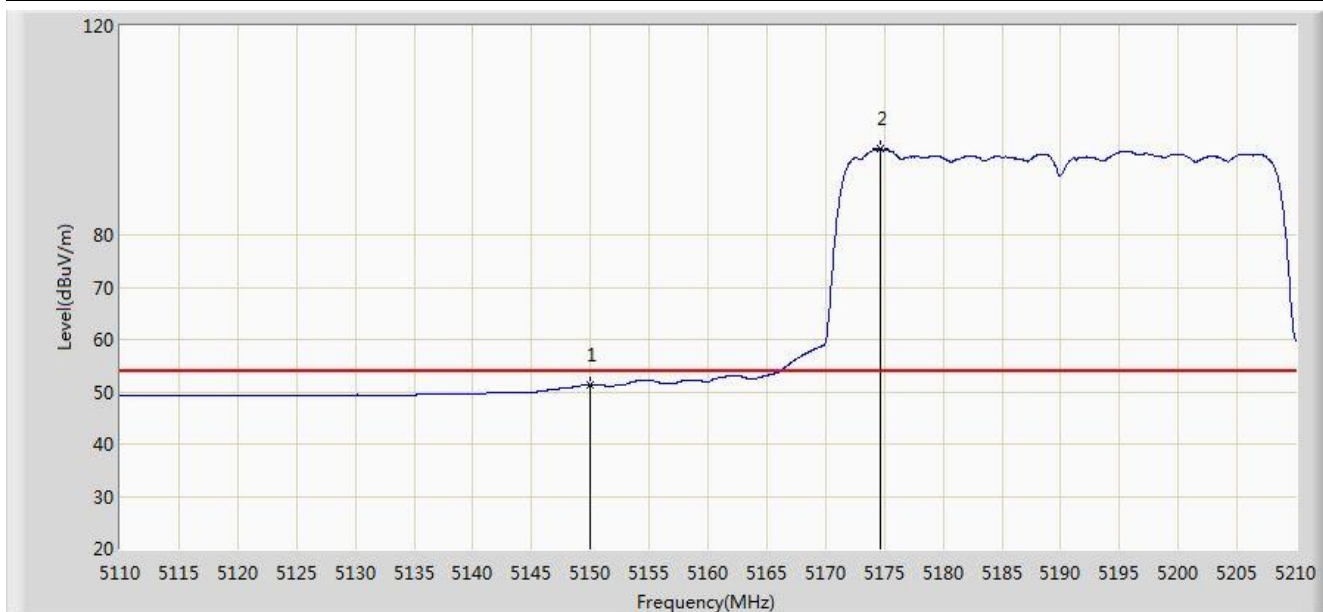

No	Flag	Mark	Frequency (MHz)	Measure Level (dBuV/m)	Reading Level (dBuV)	Over Limit (dB)	Limit (dBuV/m)	Factor (dB)	Type
1			5150.000	51.344	14.592	-2.656	54.000	36.752	AV
2		*	5174.650	96.397	59.715	N/A	N/A	36.683	AV

Note: Measure Level (dB μ V/m) = Reading Level (dB μ V) + Factor (dB)

Factor (dB) = Cable Loss (dB) + Antenna Factor (dB/m).

Engineer: Roy Cheng	
Site: AC1	Time: 2014/07/18 - 15:18
Limit: FCC_Part15.209_RE(3m)	Margin: 0
Probe: BBHA9120D_1-18GHz	Polarity: Horizontal
EUT: WIFI dual band 4 GE LAN GPON HGU	Power: AC 120V/60Hz
Note: Mode 5: Transmit by 802.11ac40 at channel 5310MHz Ant 0+1+2+3	

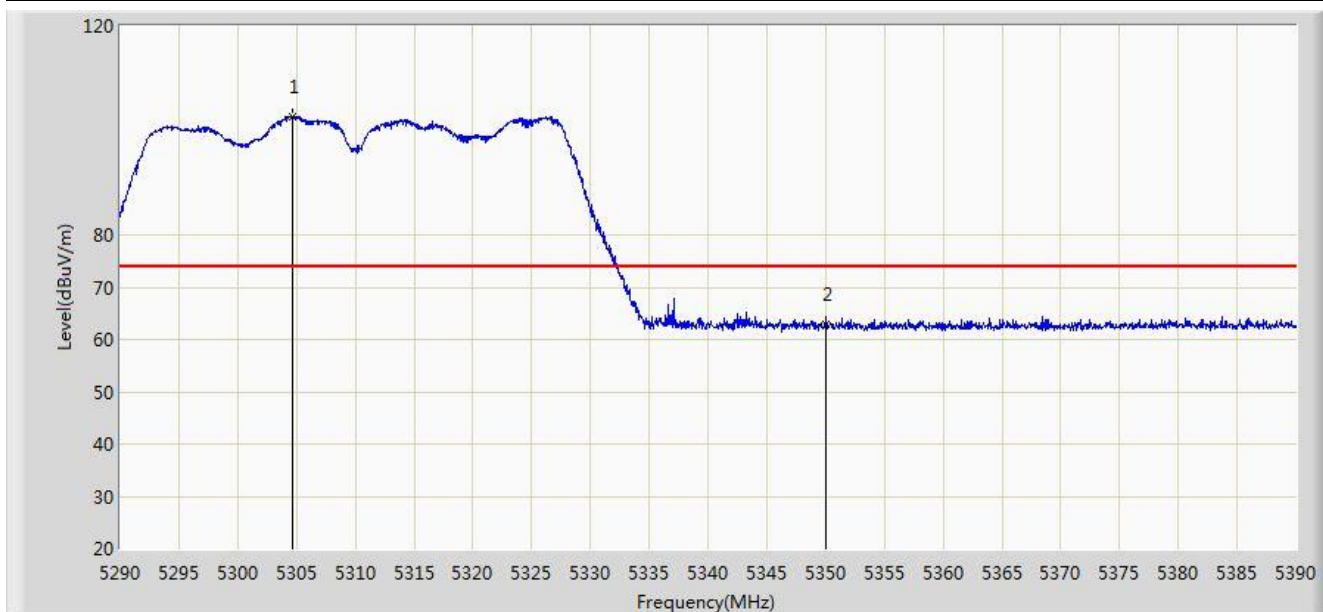

No	Flag	Mark	Frequency (MHz)	Measure Level (dBuV/m)	Reading Level (dBuV)	Over Limit (dB)	Limit (dBuV/m)	Factor (dB)	Type
1		*	5304.700	102.569	66.127	N/A	N/A	36.442	PK
2			5350.000	62.868	26.332	-11.132	74.000	36.536	PK

Note: Measure Level (dB μ V/m) = Reading Level (dB μ V) + Factor (dB)

Factor (dB) = Cable Loss (dB) + Antenna Factor (dB/m).

Engineer: Roy Cheng	
Site: AC1	Time: 2014/07/18 - 15:21
Limit: FCC_Part15.209_RE(3m)	Margin: 0
Probe: BBHA9120D_1-18GHz	Polarity: Horizontal
EUT: WIFI dual band 4 GE LAN GPON HGU	Power: AC 120V/60Hz
Note: Mode 5: Transmit by 802.11ac40 at channel 5310MHz Ant 0+1+2+3	

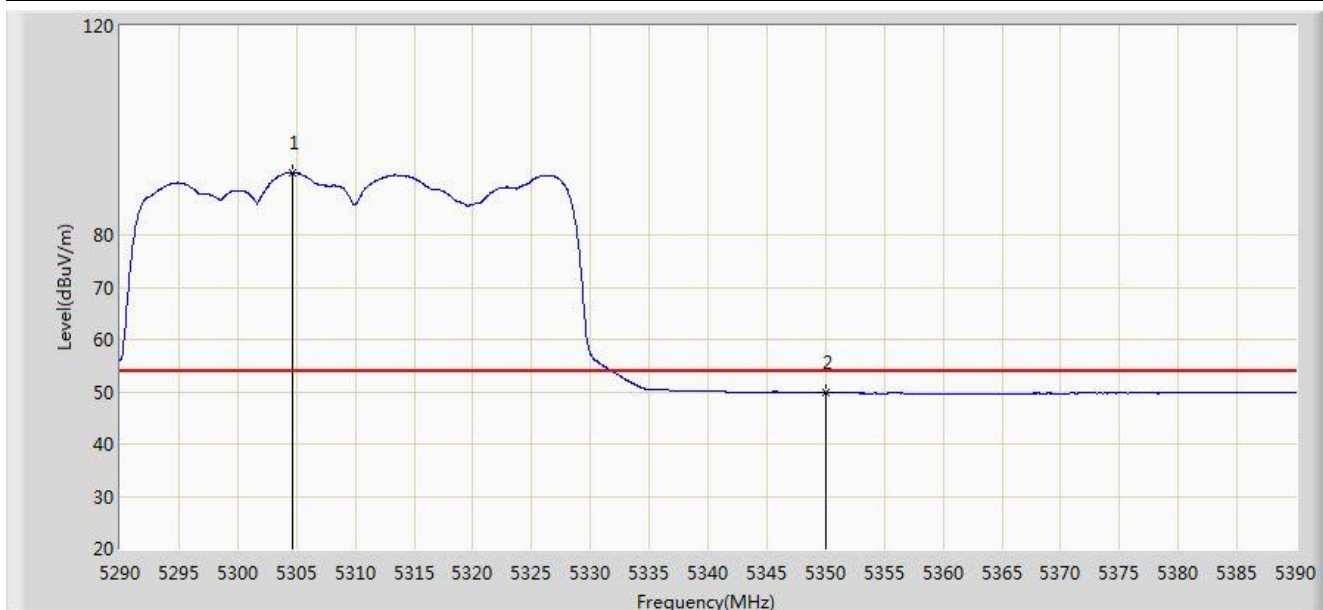

No	Flag	Mark	Frequency (MHz)	Measure Level (dBuV/m)	Reading Level (dBuV)	Over Limit (dB)	Limit (dBuV/m)	Factor (dB)	Type
1		*	5304.700	91.899	55.457	N/A	N/A	36.442	AV
2			5350.000	49.839	13.303	-4.161	54.000	36.536	AV

Note: Measure Level (dB μ V/m) = Reading Level (dB μ V) + Factor (dB)

Factor (dB) = Cable Loss (dB) + Antenna Factor (dB/m).

Engineer: Roy Cheng	
Site: AC1	Time: 2014/07/18 - 15:25
Limit: FCC_Part15.209_RE(3m)	Margin: 0
Probe: BBHA9120D_1-18GHz	Polarity: Vertical
EUT: WIFI dual band 4 GE LAN GPON HGU	Power: AC 120V/60Hz
Note: Mode 5: Transmit by 802.11ac40 at channel 5310MHz Ant 0+1+2+3	

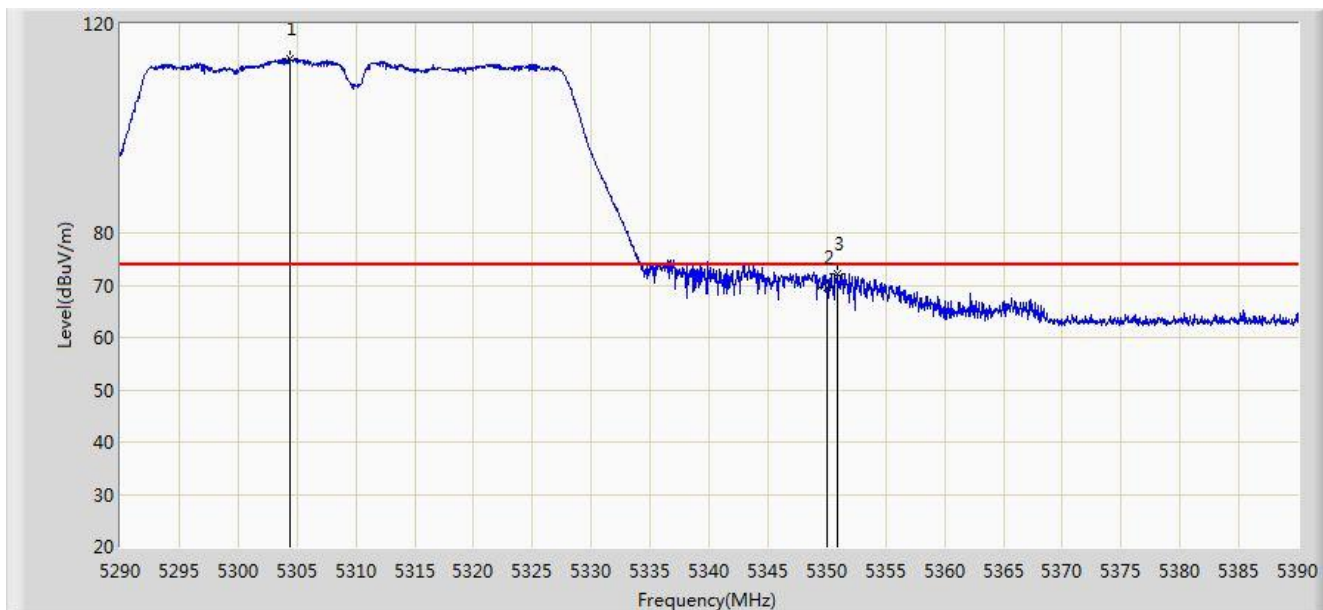

No	Flag	Mark	Frequency (MHz)	Measure Level (dBuV/m)	Reading Level (dBuV)	Over Limit (dB)	Limit (dBuV/m)	Factor (dB)	Type
1		*	5304.400	113.247	76.806	N/A	N/A	36.441	PK
2			5350.000	69.572	33.036	-4.428	74.000	36.536	PK
3			5350.900	72.231	35.693	-1.769	74.000	36.539	PK

Note: Measure Level (dBuV/m) = Reading Level (dBuV) + Factor (dB)

Factor (dB) = Cable Loss (dB) + Antenna Factor (dB/m).

Engineer: Roy Cheng	
Site: AC1	Time: 2014/07/18 - 15:26
Limit: FCC_Part15.209_RE(3m)	Margin: 0
Probe: BBHA9120D_1-18GHz	Polarity: Vertical
EUT: WIFI dual band 4 GE LAN GPON HGU	Power: AC 120V/60Hz
Note: Mode 5: Transmit by 802.11ac40 at channel 5310MHz Ant 0+1+2+3	

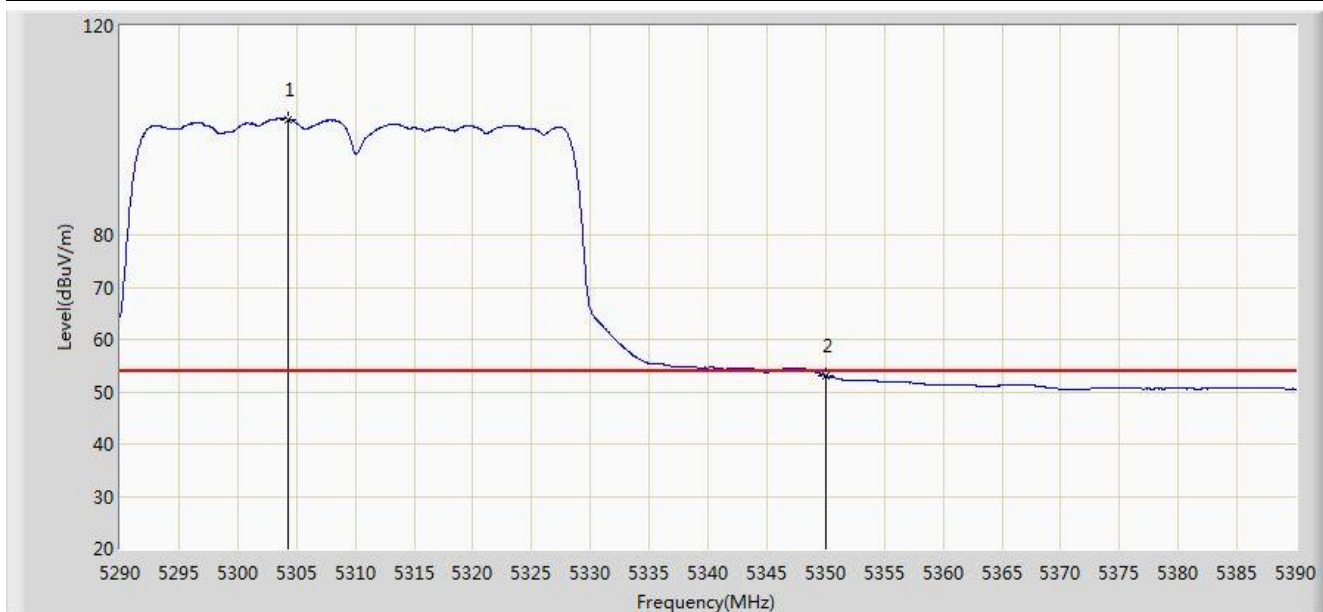

No	Flag	Mark	Frequency (MHz)	Measure Level (dBuV/m)	Reading Level (dBuV)	Over Limit (dB)	Limit (dBuV/m)	Factor (dB)	Type
1		*	5304.250	102.165	65.724	N/A	N/A	36.441	AV
2			5350.000	53.031	16.495	-0.969	54.000	36.536	AV

Note: Measure Level (dB μ V/m) = Reading Level (dB μ V) + Factor (dB)

Factor (dB) = Cable Loss (dB) + Antenna Factor (dB/m).

Engineer: Roy Cheng	
Site: AC1	Time: 2014/07/18 - 15:30
Limit: FCC_Part15.209_RE(3m)	Margin: 0
Probe: BBHA9120D_1-18GHz	Polarity: Horizontal
EUT: WIFI dual band 4 GE LAN GPON HGU	Power: AC 120V/60Hz
Note: Mode 5: Transmit by 802.11ac40 at channel 5510MHz Ant 0+1+2+3	

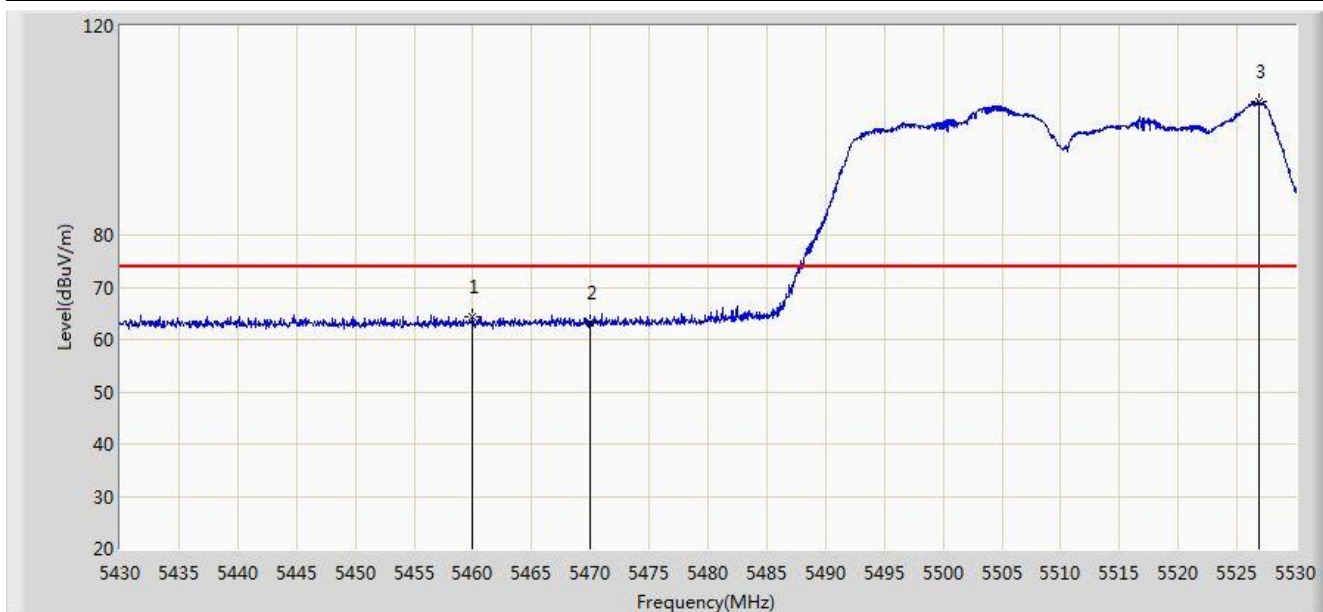

No	Flag	Mark	Frequency (MHz)	Measure Level (dBuV/m)	Reading Level (dBuV)	Over Limit (dB)	Limit (dBuV/m)	Factor (dB)	Type
1			5460.000	64.206	27.396	-9.794	74.000	36.810	PK
2			5470.000	63.144	26.319	-10.856	74.000	36.825	PK
3		*	5526.850	105.460	68.534	N/A	N/A	36.926	PK

Note: Measure Level (dB μ V/m) = Reading Level (dB μ V) + Factor (dB)

Factor (dB) = Cable Loss (dB) + Antenna Factor (dB/m).

Engineer: Roy Cheng	
Site: AC1	Time: 2014/07/18 - 15:33
Limit: FCC_Part15.209_RE(3m)	Margin: 0
Probe: BBHA9120D_1-18GHz	Polarity: Horizontal
EUT: WIFI dual band 4 GE LAN GPON HGU	Power: AC 120V/60Hz
Note: Mode 5: Transmit by 802.11ac40 at channel 5510MHz Ant 0+1+2+3	

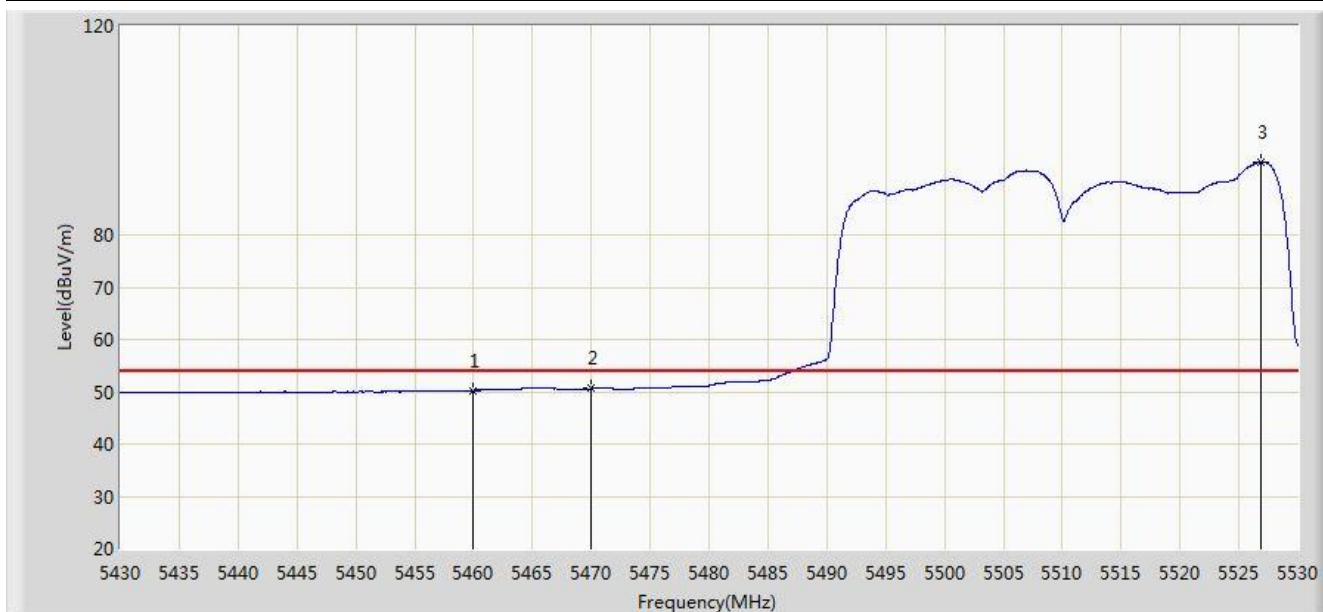

No	Flag	Mark	Frequency (MHz)	Measure Level (dBuV/m)	Reading Level (dBuV)	Over Limit (dB)	Limit (dBuV/m)	Factor (dB)	Type
1			5460.000	50.254	13.444	-3.746	54.000	36.810	AV
2			5470.000	50.589	13.764	-3.411	54.000	36.825	AV
3		*	5526.850	93.898	56.972	N/A	N/A	36.926	AV

Note: Measure Level (dB μ V/m) = Reading Level (dB μ V) + Factor (dB)

Factor (dB) = Cable Loss (dB) + Antenna Factor (dB/m).

Engineer: Roy Cheng	
Site: AC1	Time: 2014/07/18 - 15:37
Limit: FCC_Part15.209_RE(3m)	Margin: 0
Probe: BBHA9120D_1-18GHz	Polarity: Vertical
EUT: WIFI dual band 4 GE LAN GPON HGU	Power: AC 120V/60Hz
Note: Mode 5: Transmit by 802.11ac40 at channel 5510MHz Ant 0+1+2+3	

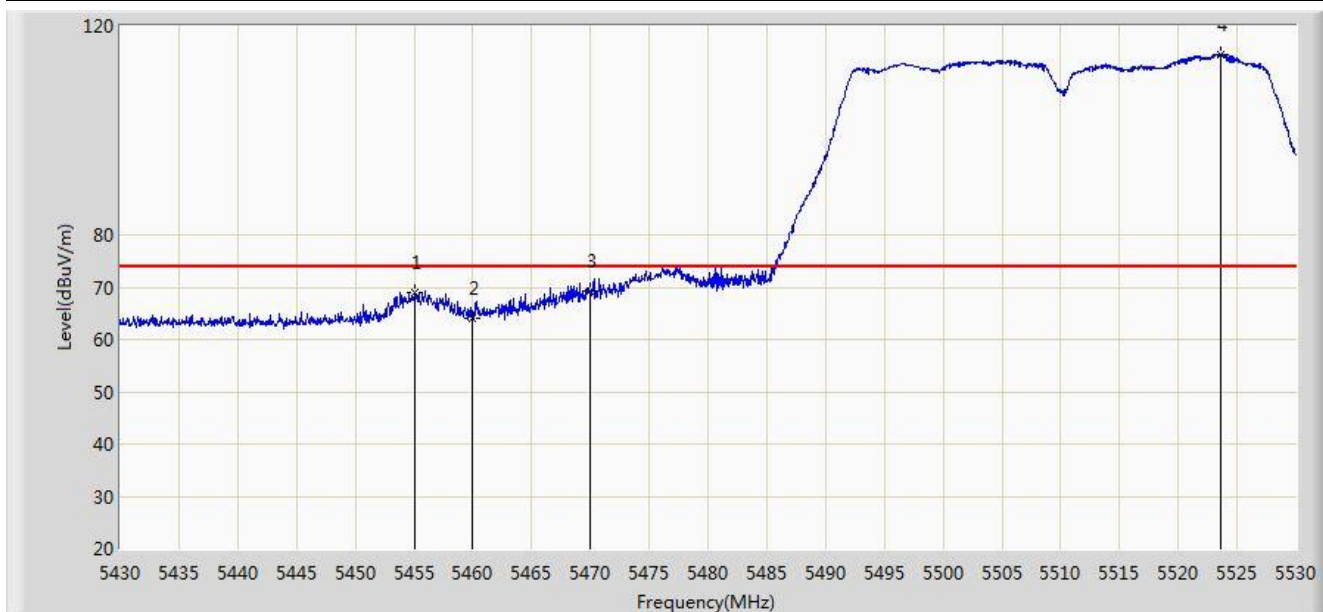

No	Flag	Mark	Frequency (MHz)	Measure Level (dBuV/m)	Reading Level (dBuV)	Over Limit (dB)	Limit (dBuV/m)	Factor (dB)	Type
1			5455.050	69.085	32.283	-4.915	74.000	36.802	PK
2			5460.000	64.123	27.313	-9.877	74.000	36.810	PK
3			5470.000	69.336	32.511	-4.664	74.000	36.825	PK
4		*	5523.550	114.495	77.572	N/A	N/A	36.923	PK

Note: Measure Level (dBuV/m) = Reading Level (dBuV) + Factor (dB)

Factor (dB) = Cable Loss (dB) + Antenna Factor (dB/m).

Engineer: Roy Cheng	
Site: AC1	Time: 2014/07/18 - 15:38
Limit: FCC_Part15.209_RE(3m)	Margin: 0
Probe: BBHA9120D_1-18GHz	Polarity: Vertical
EUT: WIFI dual band 4 GE LAN GPON HGU	Power: AC 120V/60Hz
Note: Mode 5: Transmit by 802.11ac40 at channel 5510MHz Ant 0+1+2+3	

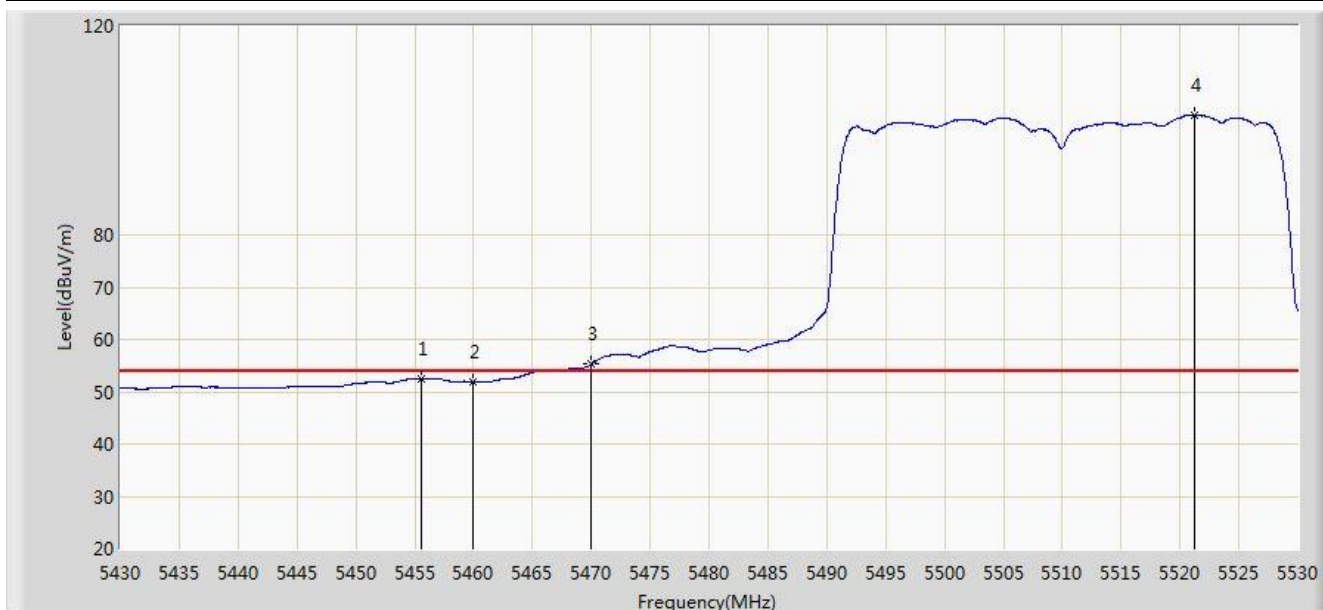

No	Flag	Mark	Frequency (MHz)	Measure Level (dBuV/m)	Reading Level (dBuV)	Over Limit (dB)	Limit (dBuV/m)	Factor (dB)	Type
1			5455.600	52.510	15.707	-1.490	54.000	36.804	AV
2			5460.000	52.002	15.192	-1.998	54.000	36.810	AV
3			5470.000	55.224	18.399	1.224	54.000	36.825	AV
4		*	5521.250	102.849	65.930	N/A	N/A	36.919	AV

Note: Measure Level (dBuV/m) = Reading Level (dBuV) + Factor (dB)

Factor (dB) = Cable Loss (dB) + Antenna Factor (dB/m).

Engineer: Roy Cheng	
Site: AC1	Time: 2014/07/18 - 15:42
Limit: FCC_Part15.209_RE(3m)	Margin: 0
Probe: BBHA9120D_1-18GHz	Polarity: Horizontal
EUT: WIFI dual band 4 GE LAN GPON HGU	Power: AC 120V/60Hz
Note: Mode 5: Transmit by 802.11ac40 at channel 5670MHz Ant 0+1+2+3	

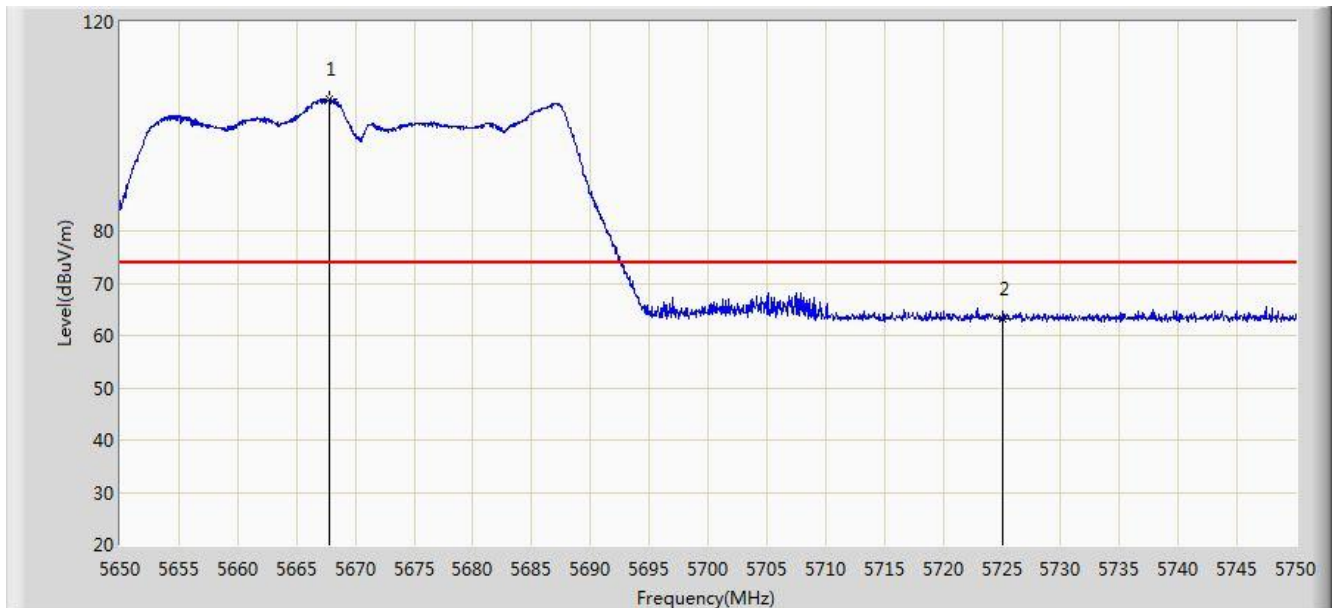

No	Flag	Mark	Frequency (MHz)	Measure Level (dBuV/m)	Reading Level (dBuV)	Over Limit (dB)	Limit (dBuV/m)	Factor (dB)	Type
1		*	5667.750	105.281	68.196	N/A	N/A	37.084	PK
2			5725.000	63.132	25.827	-10.868	74.000	37.305	PK

Note: Measure Level (dB μ V/m) = Reading Level (dB μ V) + Factor (dB)

Factor (dB) = Cable Loss (dB) + Antenna Factor (dB/m).

Engineer: Roy Cheng	
Site: AC1	Time: 2014/07/18 - 15:47
Limit: FCC_Part15.209_RE(3m)	Margin: 0
Probe: BBHA9120D_1-18GHz	Polarity: Horizontal
EUT: WIFI dual band 4 GE LAN GPON HGU	Power: AC 120V/60Hz
Note: Mode 5: Transmit by 802.11ac40 at channel 5670MHz Ant 0+1+2+3	

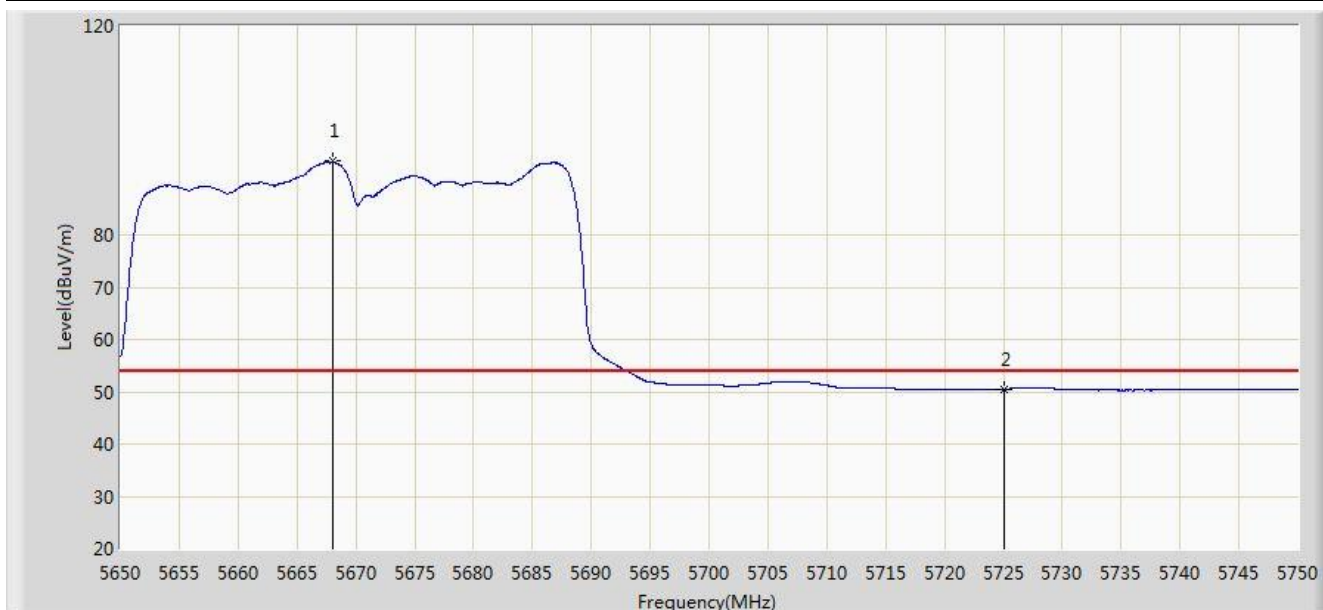

No	Flag	Mark	Frequency (MHz)	Measure Level (dBuV/m)	Reading Level (dBuV)	Over Limit (dB)	Limit (dBuV/m)	Factor (dB)	Type
1		*	5668.050	94.084	56.999	N/A	N/A	37.085	AV
2			5725.000	50.550	13.245	-3.450	54.000	37.305	AV

Note: Measure Level (dB μ V/m) = Reading Level (dB μ V) + Factor (dB)

Factor (dB) = Cable Loss (dB) + Antenna Factor (dB/m).

Engineer: Roy Cheng	
Site: AC1	Time: 2014/07/18 - 15:53
Limit: FCC_Part15.209_RE(3m)	Margin: 0
Probe: BBHA9120D_1-18GHz	Polarity: Vertical
EUT: WIFI dual band 4 GE LAN GPON HGU	Power: AC 120V/60Hz
Note: Mode 5: Transmit by 802.11ac40 at channel 5670MHz Ant 0+1+2+3	

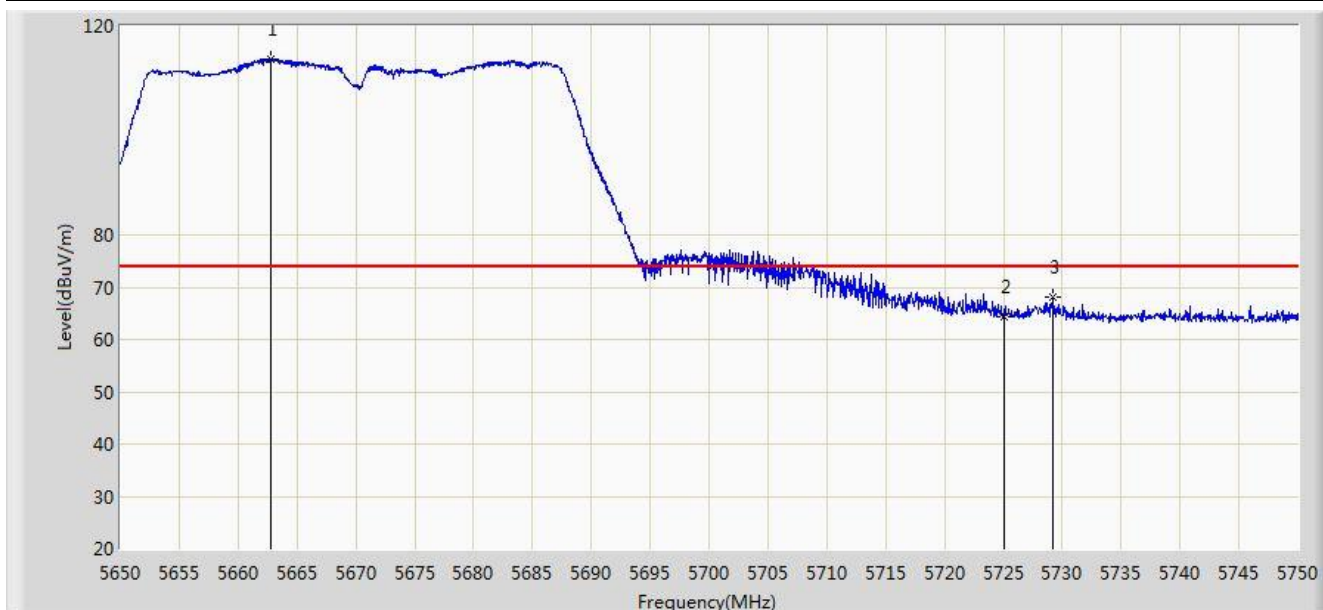

No	Flag	Mark	Frequency (MHz)	Measure Level (dBuV/m)	Reading Level (dBuV)	Over Limit (dB)	Limit (dBuV/m)	Factor (dB)	Type
1		*	5662.750	113.710	76.636	N/A	N/A	37.074	PK
2			5725.000	64.323	27.018	-9.677	74.000	37.305	PK
3			5729.150	68.234	30.912	-5.766	74.000	37.322	PK

Note: Measure Level (dB μ V/m) = Reading Level (dB μ V) + Factor (dB)

Factor (dB) = Cable Loss (dB) + Antenna Factor (dB/m).

Engineer: Roy Cheng	
Site: AC1	Time: 2014/07/18 - 15:55
Limit: FCC_Part15.209_RE(3m)	Margin: 0
Probe: BBHA9120D_1-18GHz	Polarity: Vertical
EUT: WIFI dual band 4 GE LAN GPON HGU	Power: AC 120V/60Hz
Note: Mode 5: Transmit by 802.11ac40 at channel 5670MHz Ant 0+1+2+3	

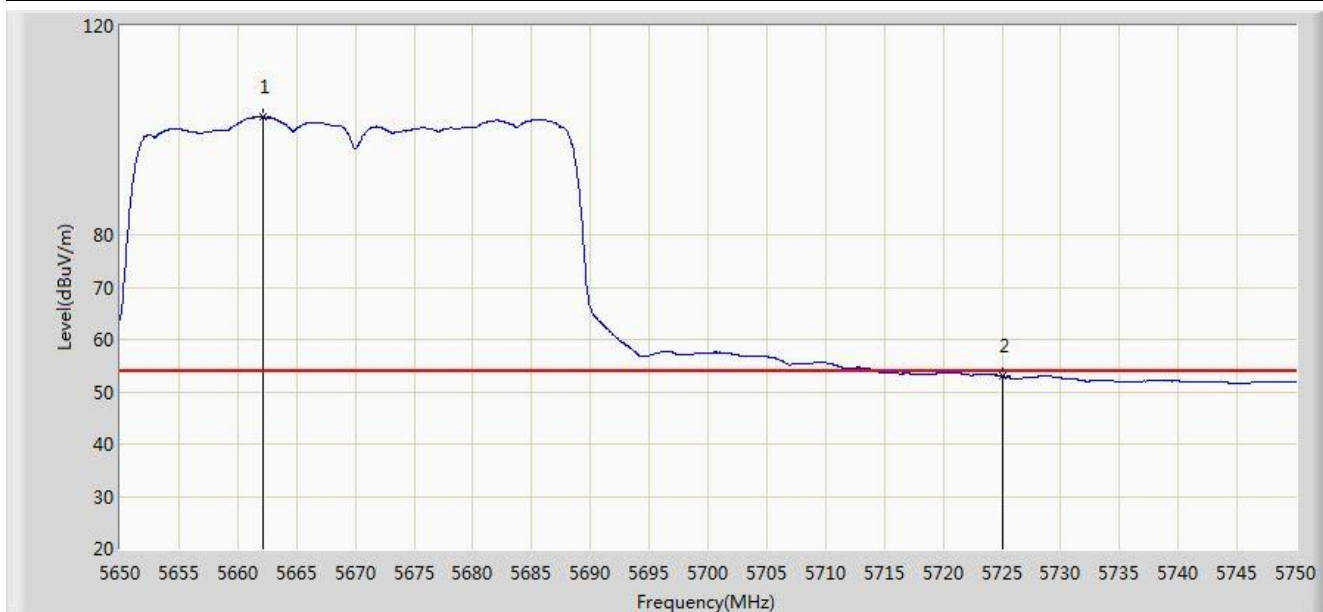

No	Flag	Mark	Frequency (MHz)	Measure Level (dBuV/m)	Reading Level (dBuV)	Over Limit (dB)	Limit (dBuV/m)	Factor (dB)	Type
1		*	5662.100	102.542	65.469	N/A	N/A	37.072	AV
2			5725.000	52.996	15.691	-1.004	54.000	37.305	AV

Note: Measure Level (dB μ V/m) = Reading Level (dB μ V) + Factor (dB)

Factor (dB) = Cable Loss (dB) + Antenna Factor (dB/m).

Engineer: Roy Cheng	
Site: AC1	Time: 2014/07/18 - 15:59
Limit: FCC_Part15.209_RE(3m)	Margin: 0
Probe: BBHA9120D_1-18GHz	Polarity: Horizontal
EUT: WIFI dual band 4 GE LAN GPON HGU	Power: AC 120V/60Hz
Note: Mode 6: Transmit by 802.11ac80 at channel 5210MHz Ant 0+1+2+3	

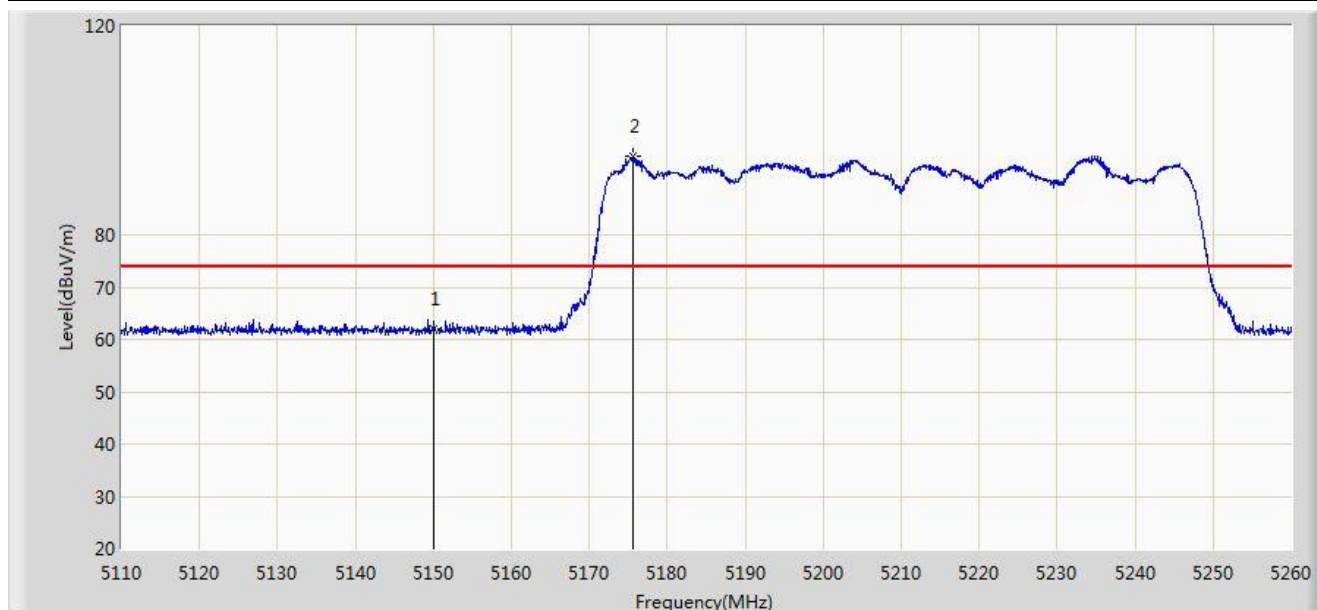

No	Flag	Mark	Frequency (MHz)	Measure Level (dBuV/m)	Reading Level (dBuV)	Over Limit (dB)	Limit (dBuV/m)	Factor (dB)	Type
1			5150.000	61.969	25.217	-12.031	74.000	36.752	PK
2		*	5175.625	94.961	58.282	N/A	N/A	36.679	PK

Note: Measure Level (dB μ V/m) = Reading Level (dB μ V) + Factor (dB)

Factor (dB) = Cable Loss (dB) + Antenna Factor (dB/m).

Engineer: Roy Cheng	
Site: AC1	Time: 2014/07/18 - 16:01
Limit: FCC_Part15.209_RE(3m)	Margin: 0
Probe: BBHA9120D_1-18GHz	Polarity: Horizontal
EUT: WIFI dual band 4 GE LAN GPON HGU	Power: AC 120V/60Hz
Note: Mode 6: Transmit by 802.11ac80 at channel 5210MHz Ant 0+1+2+3	

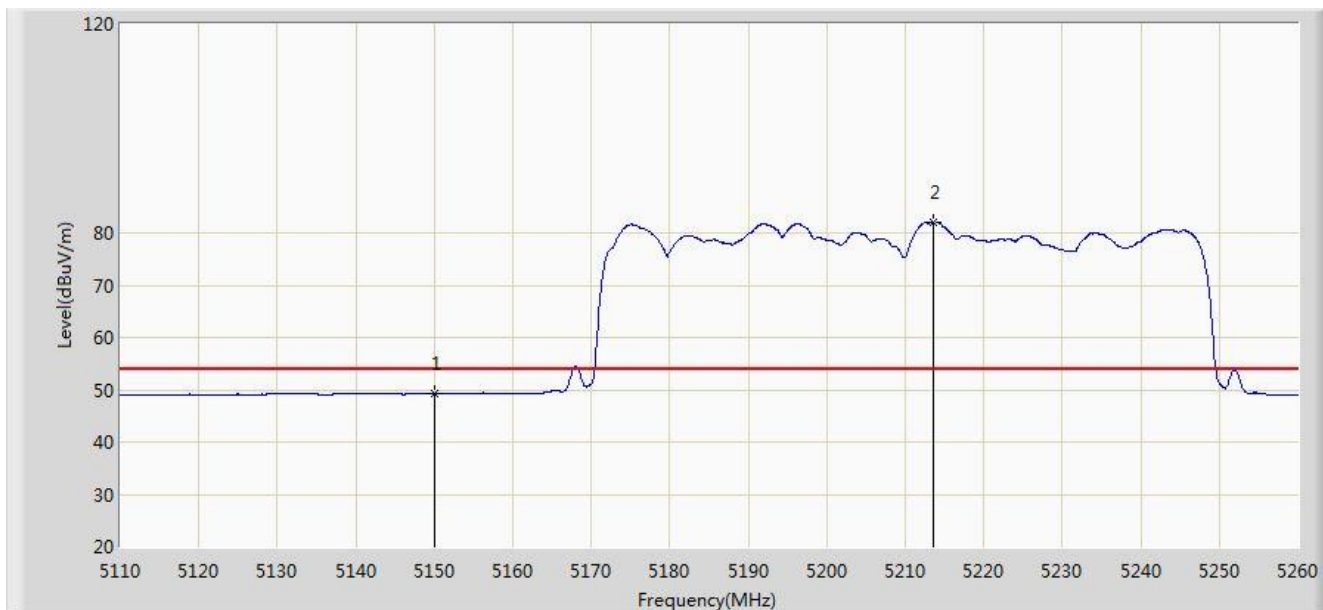

No	Flag	Mark	Frequency (MHz)	Measure Level (dBuV/m)	Reading Level (dBuV)	Over Limit (dB)	Limit (dBuV/m)	Factor (dB)	Type
1			5150.000	49.185	12.433	-4.815	54.000	36.752	AV
2		*	5213.500	82.118	45.532	N/A	N/A	36.586	AV

Note: Measure Level (dB μ V/m) = Reading Level (dB μ V) + Factor (dB)

Factor (dB) = Cable Loss (dB) + Antenna Factor (dB/m).

Engineer: Roy Cheng	
Site: AC1	Time: 2014/07/18 - 16:05
Limit: FCC_Part15.209_RE(3m)	Margin: 0
Probe: BBHA9120D_1-18GHz	Polarity: Vertical
EUT: WIFI dual band 4 GE LAN GPON HGU	Power: AC 120V/60Hz
Note: Mode 6: Transmit by 802.11ac80 at channel 5210MHz Ant 0+1+2+3	

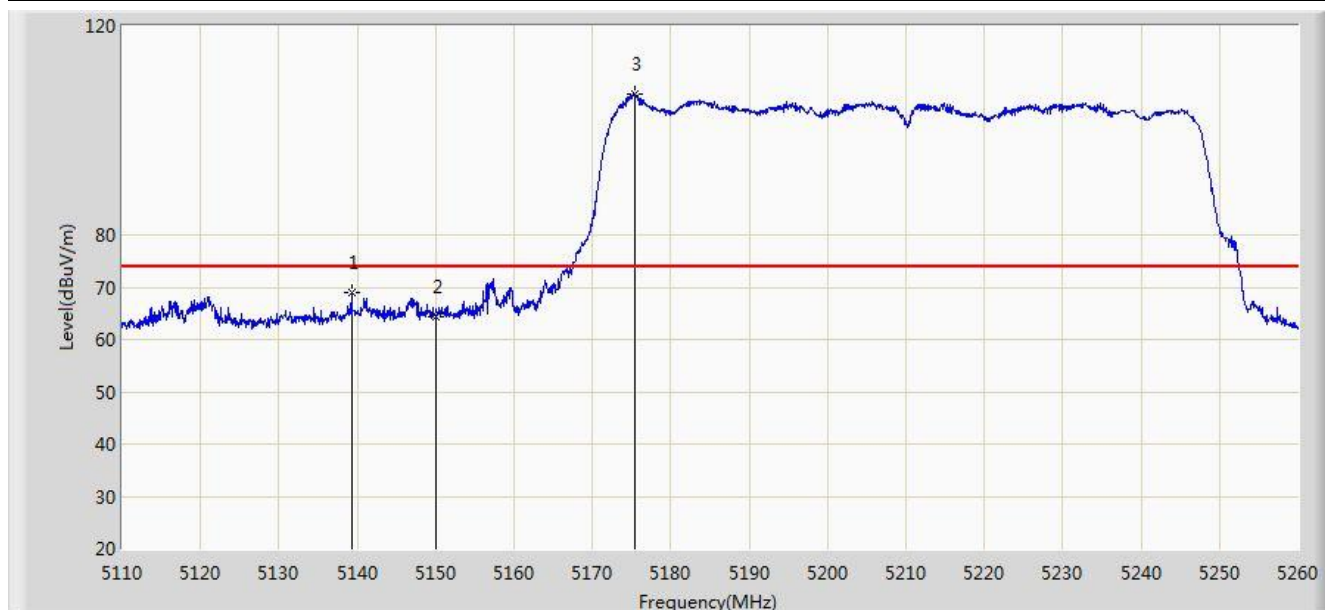

No	Flag	Mark	Frequency (MHz)	Measure Level (dBuV/m)	Reading Level (dBuV)	Over Limit (dB)	Limit (dBuV/m)	Factor (dB)	Type
1			5139.250	68.843	32.076	-5.157	74.000	36.767	PK
2			5150.000	64.352	27.600	-9.648	74.000	36.752	PK
3		*	5175.475	106.933	70.253	N/A	N/A	36.680	PK

Note: Measure Level (dBuV/m) = Reading Level (dBuV) + Factor (dB)

Factor (dB) = Cable Loss (dB) + Antenna Factor (dB/m).

Engineer: Roy Cheng	
Site: AC1	Time: 2014/07/18 - 16:06
Limit: FCC_Part15.209_RE(3m)	Margin: 0
Probe: BBHA9120D_1-18GHz	Polarity: Vertical
EUT: WIFI dual band 4 GE LAN GPON HGU	Power: AC 120V/60Hz
Note: Mode 6: Transmit by 802.11ac80 at channel 5210MHz Ant	

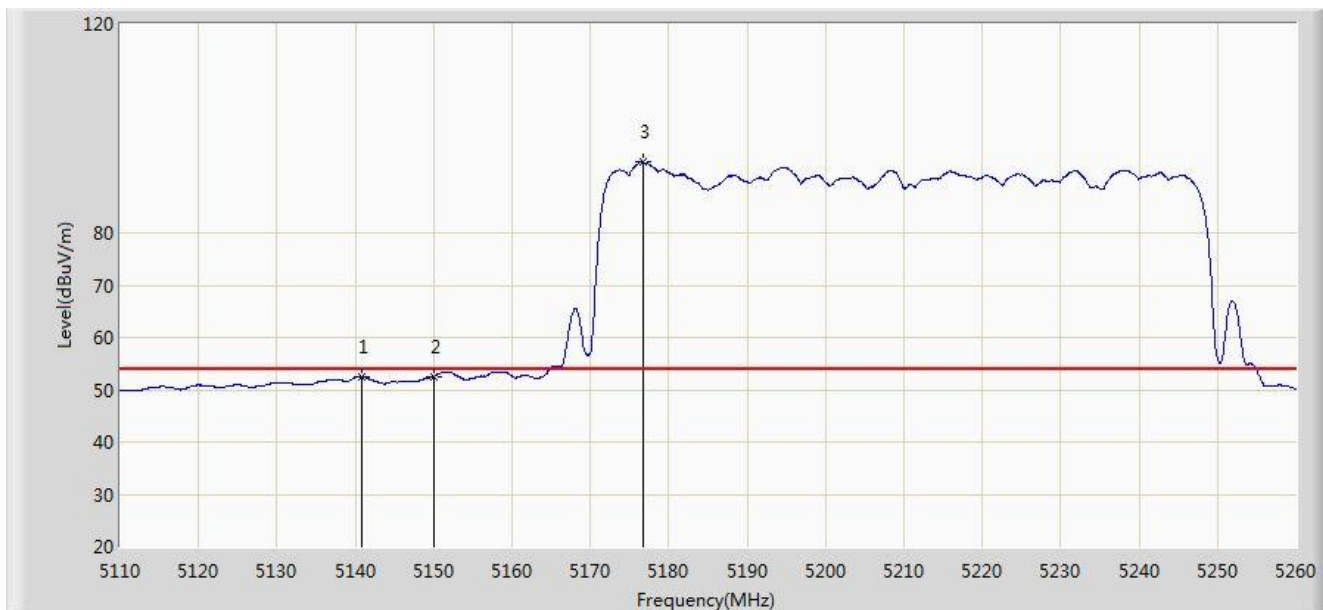

No	Flag	Mark	Frequency (MHz)	Measure Level (dBuV/m)	Reading Level (dBuV)	Over Limit (dB)	Limit (dBuV/m)	Factor (dB)	Type
1			5140.750	52.493	15.728	-1.507	54.000	36.765	AV
2			5150.000	52.483	15.731	-1.517	54.000	36.752	AV
3		*	5176.675	93.507	56.831	N/A	N/A	36.676	AV

Note: Measure Level (dBuV/m) = Reading Level (dBuV) + Factor (dB)

Factor (dB) = Cable Loss (dB) + Antenna Factor (dB/m).

Engineer: Roy Cheng	
Site: AC1	Time: 2014/07/18 - 16:26
Limit: FCC_Part15.209_RE(3m)	Margin: 0
Probe: BBHA9120D_1-18GHz	Polarity: Horizontal
EUT: WIFI dual band 4 GE LAN GPON HGU	Power: AC 120V/60Hz
Note: Mode 6: Transmit by 802.11ac80 at channel 5290MHz Ant 0+1+2+3	

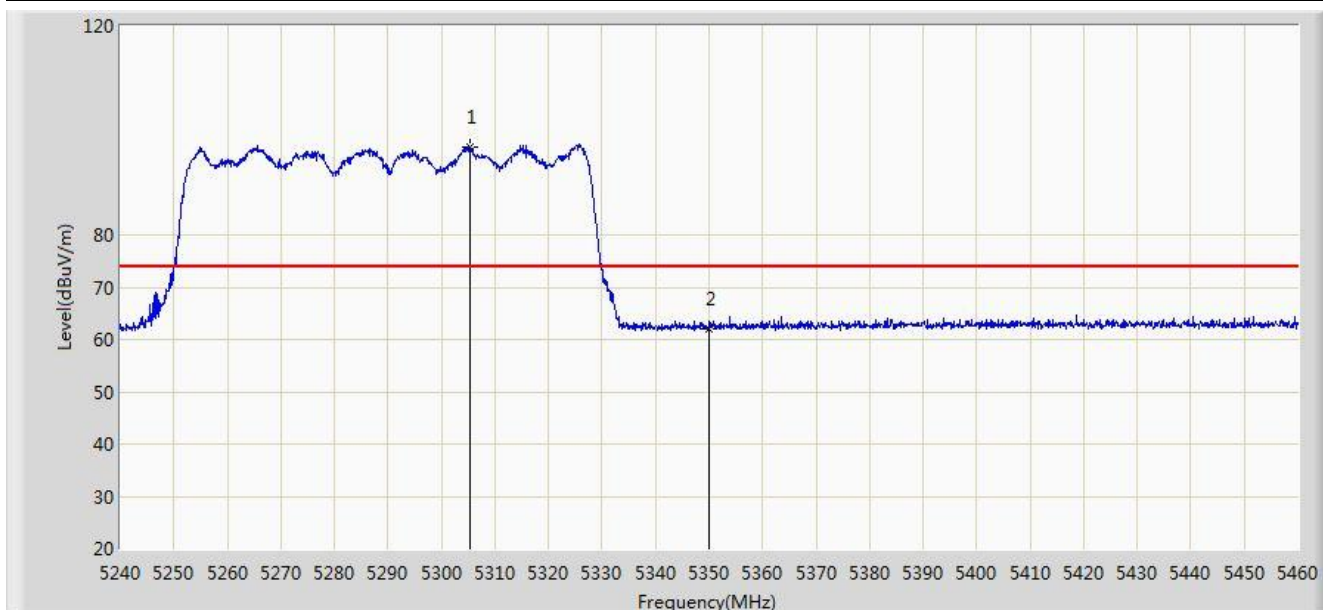

No	Flag	Mark	Frequency (MHz)	Measure Level (dBuV/m)	Reading Level (dBuV)	Over Limit (dB)	Limit (dBuV/m)	Factor (dB)	Type
1		*	5305.230	96.732	60.289	N/A	N/A	36.442	PK
2			5350.000	62.074	25.538	-11.926	74.000	36.536	PK

Note: Measure Level (dB μ V/m) = Reading Level (dB μ V) + Factor (dB)

Factor (dB) = Cable Loss (dB) + Antenna Factor (dB/m).

Engineer: Roy Cheng	
Site: AC1	Time: 2014/07/18 - 16:29
Limit: FCC_Part15.209_RE(3m)	Margin: 0
Probe: BBHA9120D_1-18GHz	Polarity: Horizontal
EUT: WIFI dual band 4 GE LAN GPON HGU	Power: AC 120V/60Hz
Note: Mode 6: Transmit by 802.11ac80 at channel 5290MHz Ant 0+1+2+3	

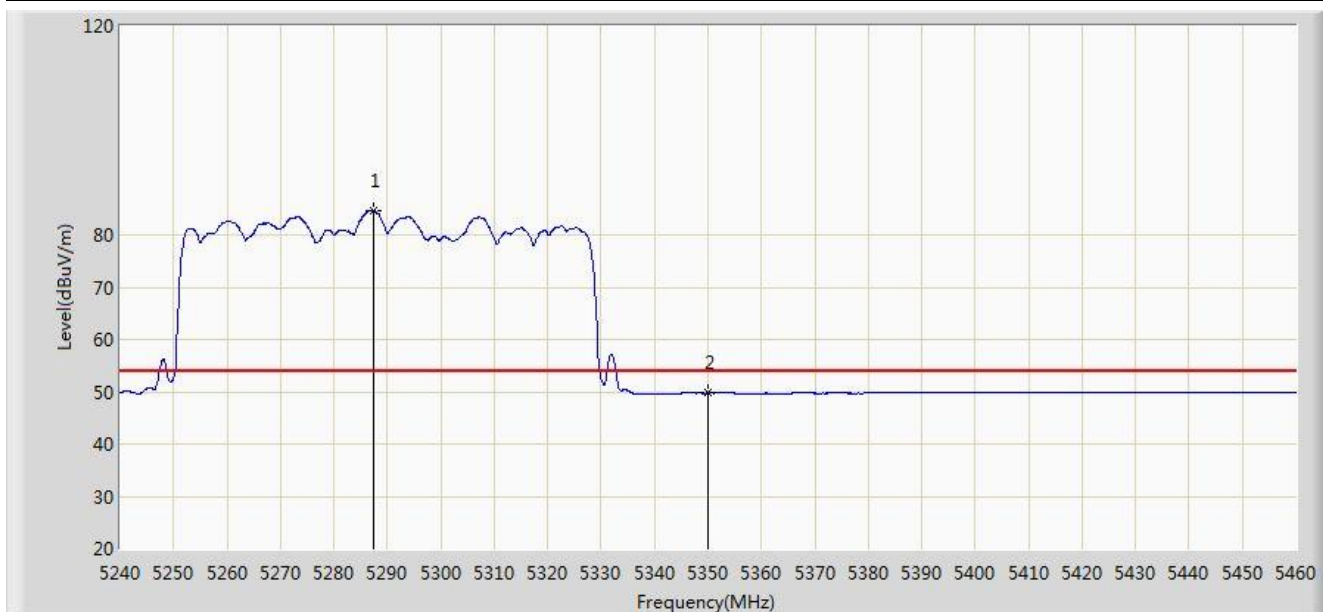

No	Flag	Mark	Frequency (MHz)	Measure Level (dBuV/m)	Reading Level (dBuV)	Over Limit (dB)	Limit (dBuV/m)	Factor (dB)	Type
1		*	5287.410	84.640	48.208	N/A	N/A	36.432	AV
2			5350.000	49.745	13.209	-4.255	54.000	36.536	AV

Note: Measure Level (dB μ V/m) = Reading Level (dB μ V) + Factor (dB)

Factor (dB) = Cable Loss (dB) + Antenna Factor (dB/m).

Engineer: Roy Cheng	
Site: AC1	Time: 2014/07/18 - 16:34
Limit: FCC_Part15.209_RE(3m)	Margin: 0
Probe: BBHA9120D_1-18GHz	Polarity: Vertical
EUT: WIFI dual band 4 GE LAN GPON HGU	Power: AC 120V/60Hz
Note: Mode 6: Transmit by 802.11ac80 at channel 5290MHz Ant 0+1+2+3	

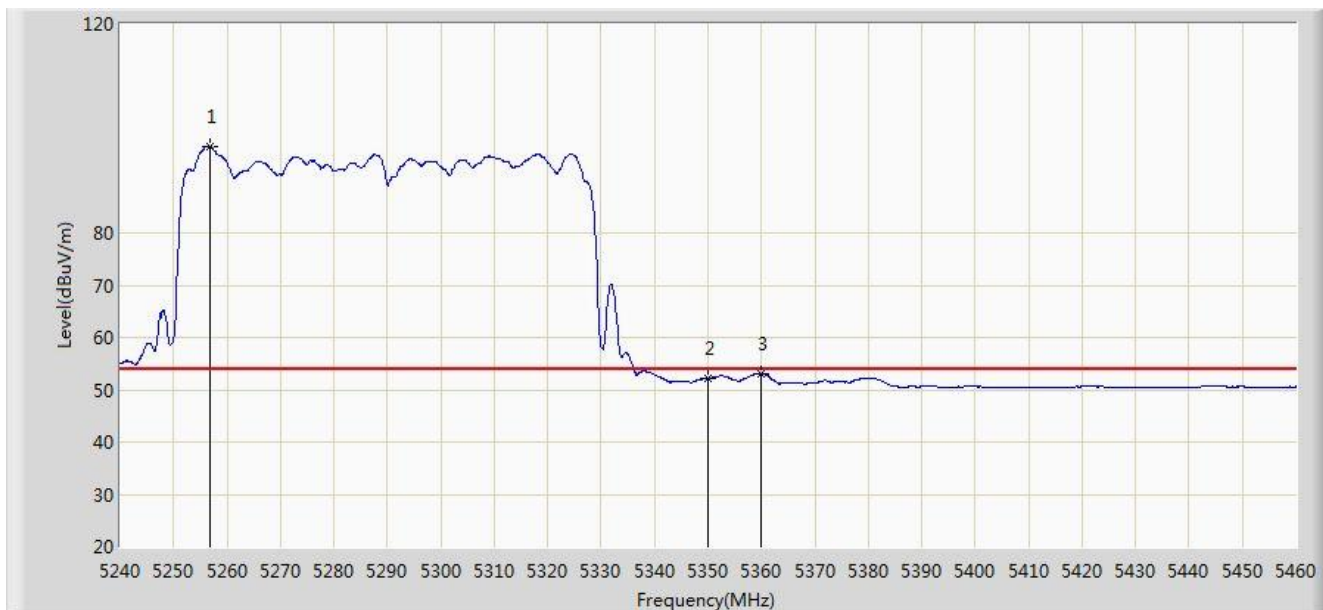

No	Flag	Mark	Frequency (MHz)	Measure Level (dBuV/m)	Reading Level (dBuV)	Over Limit (dB)	Limit (dBuV/m)	Factor (dB)	Type
1		*	5256.830	96.562	60.101	N/A	N/A	36.462	AV
2			5350.000	52.195	15.659	-1.805	54.000	36.536	AV
3			5360.010	53.085	16.525	-0.915	54.000	36.560	AV

Note: Measure Level (dB μ V/m) = Reading Level (dB μ V) + Factor (dB)

Factor (dB) = Cable Loss (dB) + Antenna Factor (dB/m).

Engineer: Roy Cheng	
Site: AC1	Time: 2014/07/18 - 16:34
Limit: FCC_Part15.209_RE(3m)	Margin: 0
Probe: BBHA9120D_1-18GHz	Polarity: Vertical
EUT: WIFI dual band 4 GE LAN GPON HGU	Power: AC 120V/60Hz
Note: Mode 6: Transmit by 802.11ac80 at channel 5290MHz Ant 0+1+2+3	

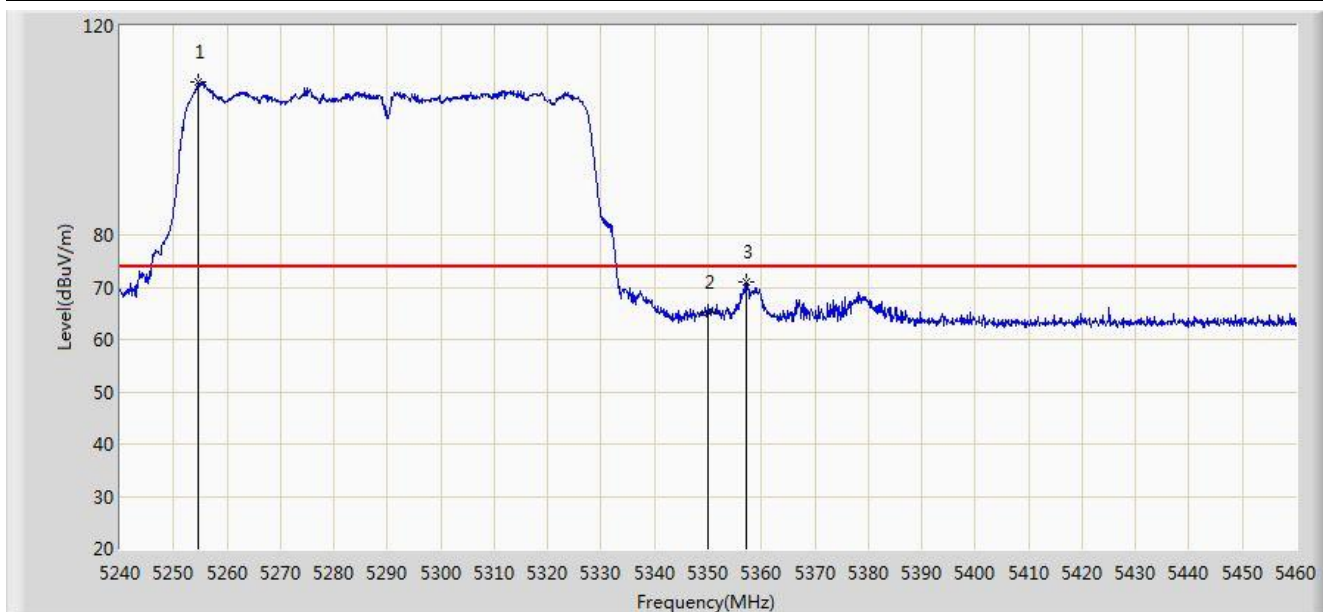

No	Flag	Mark	Frequency (MHz)	Measure Level (dBuV/m)	Reading Level (dBuV)	Over Limit (dB)	Limit (dBuV/m)	Factor (dB)	Type
1		*	5254.740	109.345	72.882	N/A	N/A	36.466	PK
2			5350.000	65.269	28.733	-8.731	74.000	36.536	PK
3			5357.040	71.146	34.594	-2.854	74.000	36.553	PK

Note: Measure Level (dBuV/m) = Reading Level (dBuV) + Factor (dB)

Factor (dB) = Cable Loss (dB) + Antenna Factor (dB/m).

Engineer: Roy Cheng	
Site: AC1	Time: 2014/07/18 - 16:38
Limit: FCC_Part15.209_RE(3m)	Margin: 0
Probe: BBHA9120D_1-18GHz	Polarity: Horizontal
EUT: WIFI dual band 4 GE LAN GPON HGU	Power: AC 120V/60Hz
Note: Mode 6: Transmit by 802.11ac80 at channel 5530MHz Ant 0+1+2+3	

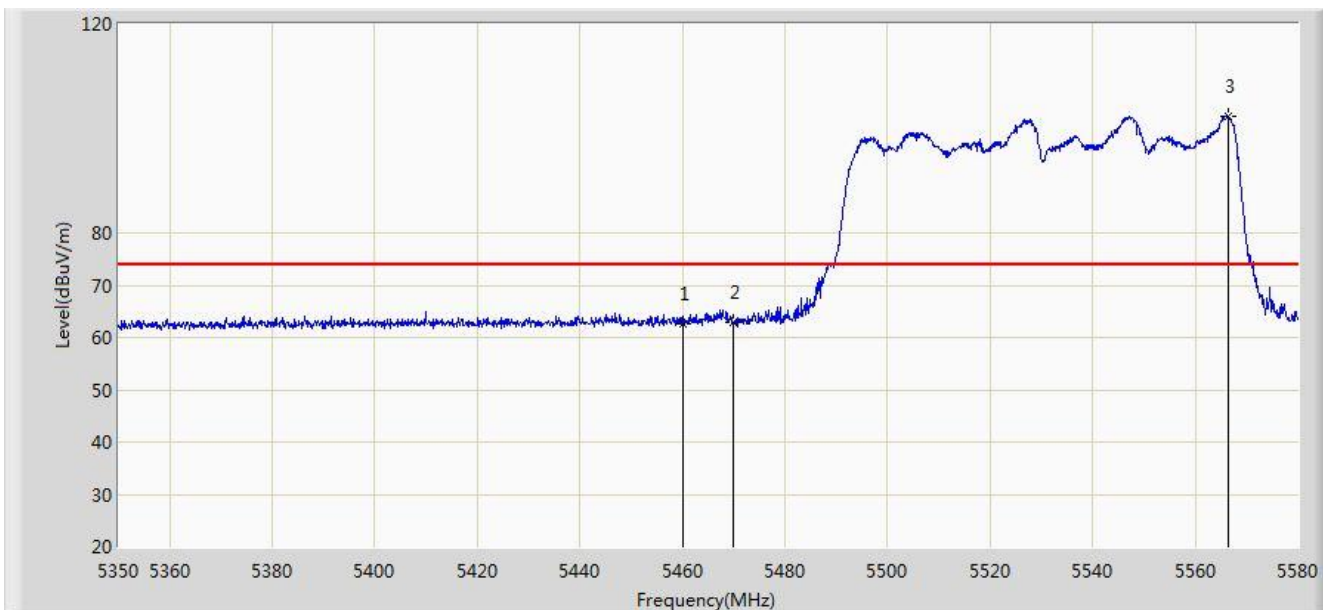

No	Flag	Mark	Frequency (MHz)	Measure Level (dBuV/m)	Reading Level (dBuV)	Over Limit (dB)	Limit (dBuV/m)	Factor (dB)	Type
1			5460.000	62.521	25.711	-11.479	74.000	36.810	PK
2			5470.000	62.927	26.102	-11.073	74.000	36.825	PK
3		*	5566.315	102.263	65.337	N/A	N/A	36.926	PK

Note: Measure Level (dBuV/m) = Reading Level (dBuV) + Factor (dB)

Factor (dB) = Cable Loss (dB) + Antenna Factor (dB/m).

Engineer: Roy Cheng	
Site: AC1	Time: 2014/07/18 - 16:41
Limit: FCC_Part15.209_RE(3m)	Margin: 0
Probe: BBHA9120D_1-18GHz	Polarity: Horizontal
EUT: WIFI dual band 4 GE LAN GPON HGU	Power: AC 120V/60Hz
Note: Mode 6: Transmit by 802.11ac80 at channel 5530MHz Ant 0+1+2+3	

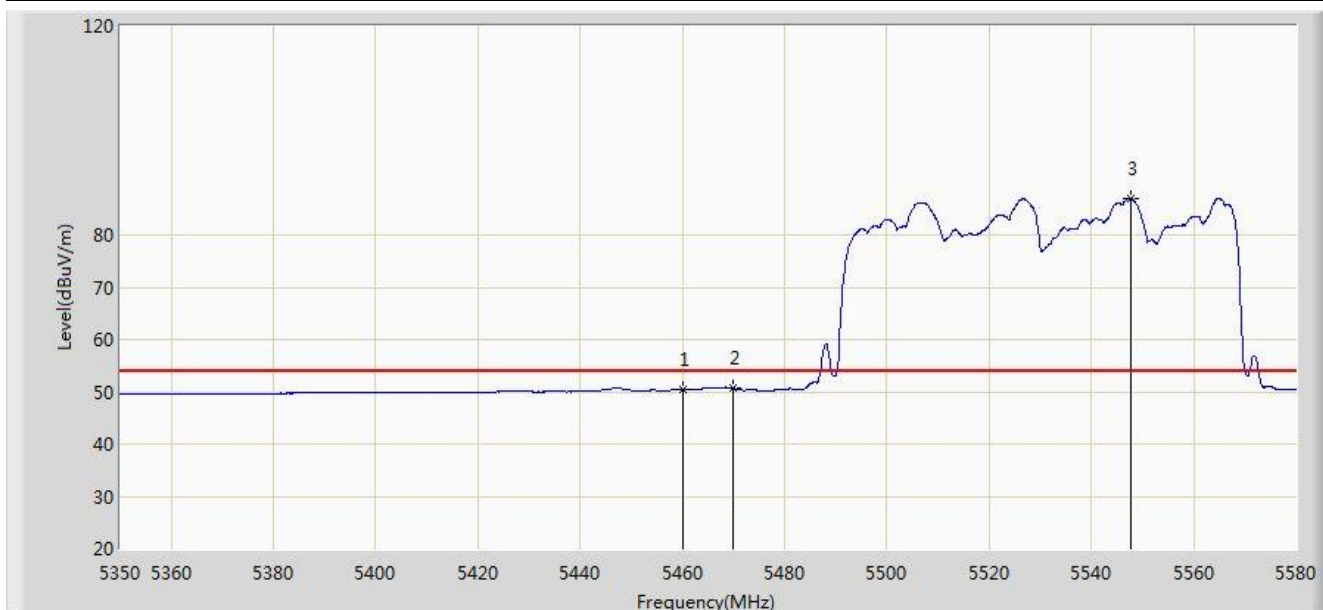

No	Flag	Mark	Frequency (MHz)	Measure Level (dBuV/m)	Reading Level (dBuV)	Over Limit (dB)	Limit (dBuV/m)	Factor (dB)	Type
1			5460.000	50.433	13.623	-3.567	54.000	36.810	AV
2			5470.000	50.622	13.797	-3.378	54.000	36.825	AV
3		*	5547.685	87.009	50.079	N/A	N/A	36.930	AV

Note: Measure Level (dBuV/m) = Reading Level (dBuV) + Factor (dB)

Factor (dB) = Cable Loss (dB) + Antenna Factor (dB/m).

Engineer: Roy Cheng	
Site: AC1	Time: 2014/07/18 - 16:51
Limit: FCC_Part15.209_RE(3m)	Margin: 0
Probe: BBHA9120D_1-18GHz	Polarity: Vertical
EUT: WIFI dual band 4 GE LAN GPON HGU	Power: AC 120V/60Hz
Note: Mode 6: Transmit by 802.11ac80 at channel 5530MHz Ant 0+1+2+3	

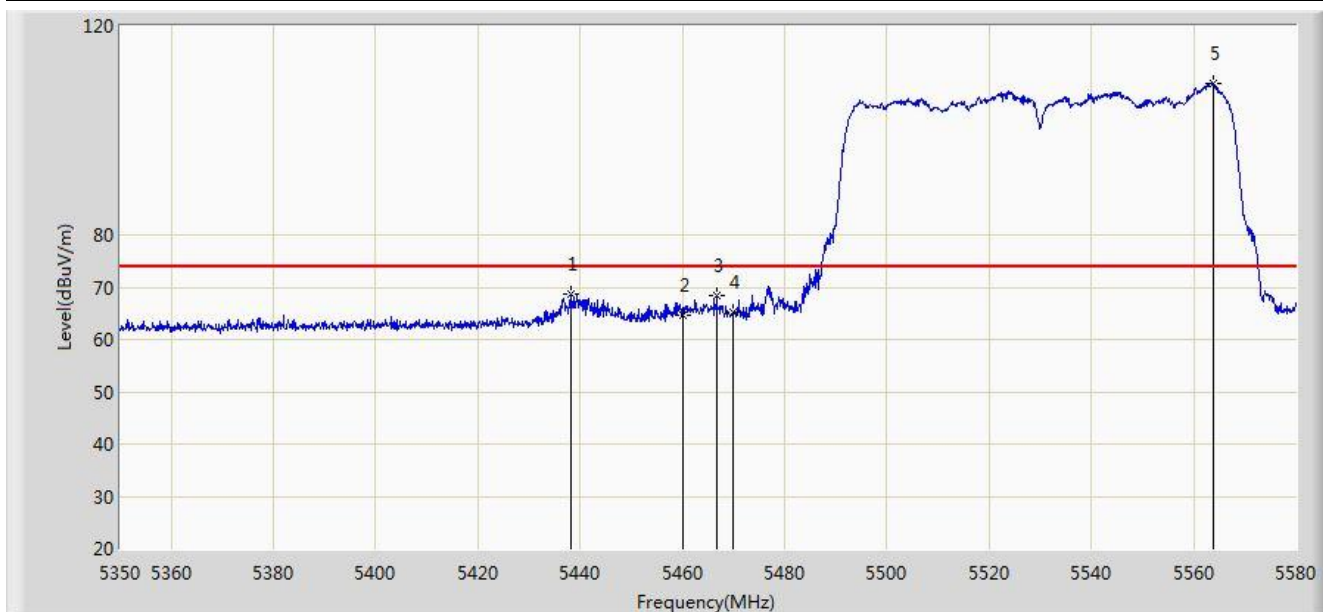

No	Flag	Mark	Frequency (MHz)	Measure Level (dBuV/m)	Reading Level (dBuV)	Over Limit (dB)	Limit (dBuV/m)	Factor (dB)	Type
1			5438.320	68.648	31.884	-5.352	74.000	36.764	PK
2			5460.000	64.772	27.962	-9.228	74.000	36.810	PK
3			5466.725	68.546	31.726	-5.454	74.000	36.820	PK
4			5470.000	65.113	28.288	-8.887	74.000	36.825	PK
5		*	5563.900	108.871	71.946	34.871	74.000	36.925	PK

Note: Measure Level (dB μ V/m) = Reading Level (dB μ V) + Factor (dB)

Factor (dB) = Cable Loss (dB) + Antenna Factor (dB/m).

Engineer: Roy Cheng	
Site: AC1	Time: 2014/07/18 - 16:47
Limit: FCC_Part15.209_RE(3m)	Margin: 0
Probe: BBHA9120D_1-18GHz	Polarity: Vertical
EUT: WIFI dual band 4 GE LAN GPON HGU	Power: AC 120V/60Hz
Note: Mode 6: Transmit by 802.11ac80 at channel 5530MHz Ant 0+1+2+3	

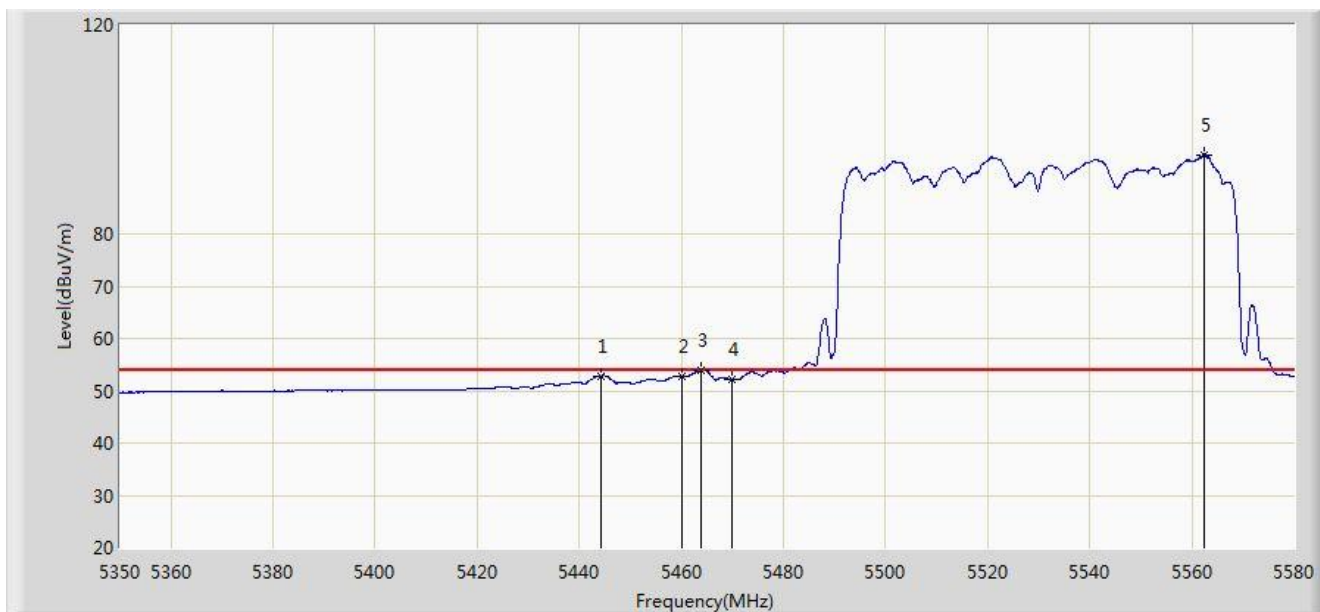

No	Flag	Mark	Frequency (MHz)	Measure Level (dBuV/m)	Reading Level (dBuV)	Over Limit (dB)	Limit (dBuV/m)	Factor (dB)	Type
1			5444.300	52.841	16.063	-1.159	54.000	36.778	AV
2			5460.000	52.776	15.966	-1.224	54.000	36.810	AV
3			5463.965	53.849	15.033	-0.151	54.000	36.816	AV
4			5470.000	52.085	15.260	-1.915	54.000	36.825	AV
5		*	5562.405	95.153	58.228	N/A	N/A	36.925	AV

Note: Measure Level (dB μ V/m) = Reading Level (dB μ V) + Factor (dB)

Factor (dB) = Cable Loss (dB) + Antenna Factor (dB/m).

7.10. AC Conducted Emissions Measurement §15.207; RSS-210 [7.2.4]

7.10.1. Test Limit

FCC Part 15 Subpart C Paragraph 15.207 & RSS-210 [7.2.4]		
Frequency (MHz)	QP (dB μ V)	AV (dB μ V)
0.15 - 0.50	66 - 56	56 - 46
0.50 - 5.0	56	46
5.0 - 30	60	50

Note 1: The lower limit shall apply at the transition frequencies.

Note 2: The limit decreases linearly with the logarithm of the frequency in the range 0.15MHz to 0.5MHz.

7.10.2. Test Procedure

The EUT was setup according to ANSI C63.4, 2009 and tested according to KDB 789033 for compliance to FCC 47CFR 15.247 requirements. The EUT was placed on a platform of nominal size, 1 m by 1.5 m, raised 80 cm above the conducting ground plane. The vertical conducting plane was located 40 cm to the rear of the EUT. All other surfaces of EUT were at least 80 cm from any other grounded conducting surface. The EUT and simulators are connected to the main power through a line impedance stabilization network (LISN). The LISN provides a 50 ohm /50 μ H coupling impedance for the measuring equipment. The peripheral devices are also connected to the main power through a LISN. (Please refer to the block diagram of the test setup and photographs) Each current-carrying conductor of the EUT power cord, except the ground (safety) conductor, was individually connected through a LISN to the input power source.

The excess length of the power cord between the EUT and the LISN receptacle were folded back and forth at the center of the lead to form a bundle not exceeding 40 cm in length.

Conducted emissions were investigated over the frequency range from 0.15MHz to 30MHz using a receiver bandwidth of 9 kHz.

7.10.3. Test Setup

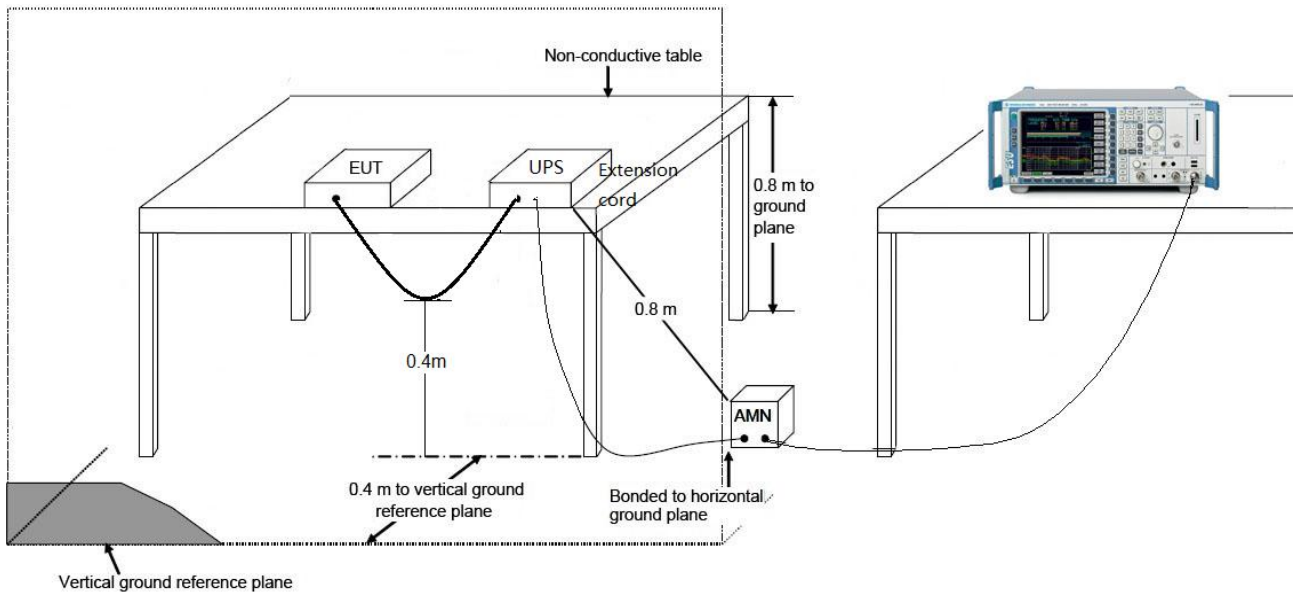

7.10.4. Test Result

Tested By	Roy Cheng	Test Date	2014/07/15 - 11:48
Site	SR2	Power	AC 120V/60Hz
Limit	FCC_Part15.207_CE_Class B	Polarity	Line
AMN	LISN_101683-FILTER ON	Test Mode	Normal Operation

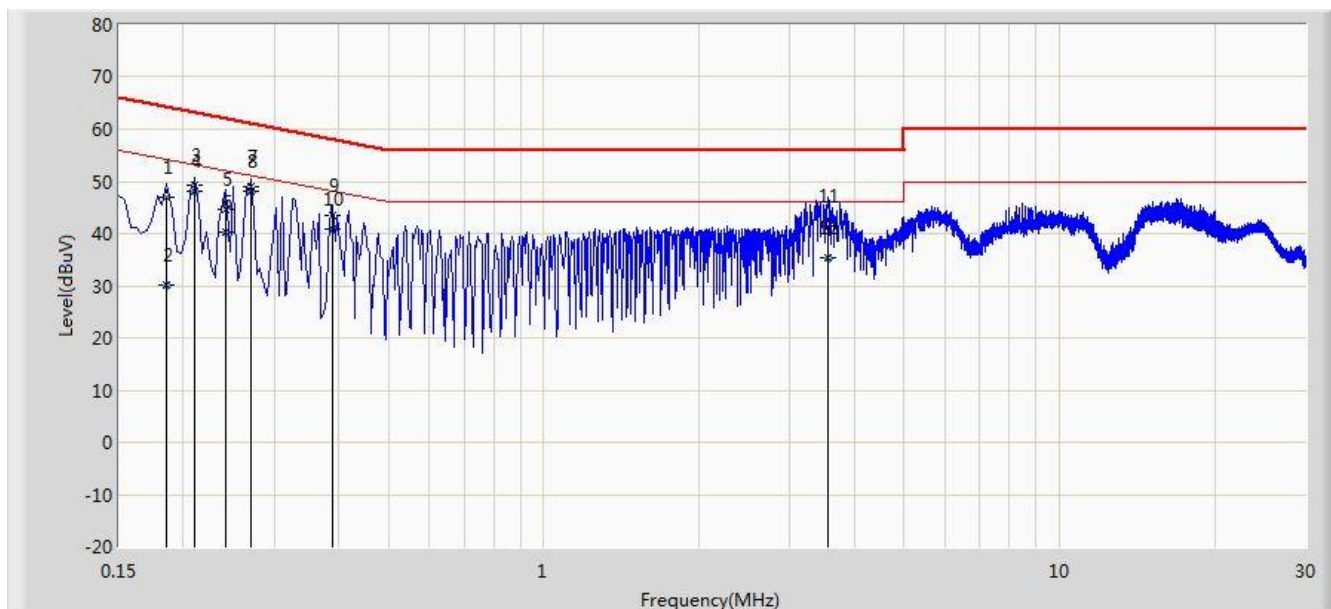

No	Flag	Mark	Frequency (MHz)	Measure Level (dBuV)	Reading Level (dBuV)	Over Limit (dB)	Limit (dBuV)	Factor (dB)	Type
1			0.186	46.970	36.935	-17.243	64.213	10.035	QP
2			0.186	30.198	20.162	-24.016	54.213	10.035	AV
3		*	0.210	49.275	39.281	-13.930	63.205	9.995	QP
4			0.210	48.161	38.167	-5.044	53.205	9.995	AV
5			0.242	44.585	34.590	-17.442	62.027	9.995	QP
6			0.242	40.350	30.355	-11.677	52.027	9.995	AV
7			0.270	49.083	39.067	-12.035	61.118	10.016	QP
8			0.270	47.979	37.963	-3.139	51.118	10.016	AV
9			0.390	43.467	33.362	-14.597	58.064	10.105	QP
10			0.390	40.835	30.730	-7.228	48.064	10.105	AV
11			3.546	41.421	31.503	-14.579	56.000	9.919	QP
12			3.546	35.301	25.382	-10.699	46.000	9.919	AV

Note: Measure Level (dBμV) = Reading Level (dBμV) + Factor (dB)

Factor (dB) = Cable Loss (dB) + LISN Factor (dB)

Tested By	Roy Cheng	Test Date	2014/07/15 - 11:54
Site	SR2	Power	AC 120V/60Hz
Limit	FCC_Part15.207_CE_Class B	Polarity	Neutral
AMN	LISN_101683-FILTER ON	Test Mode	Normal Operation

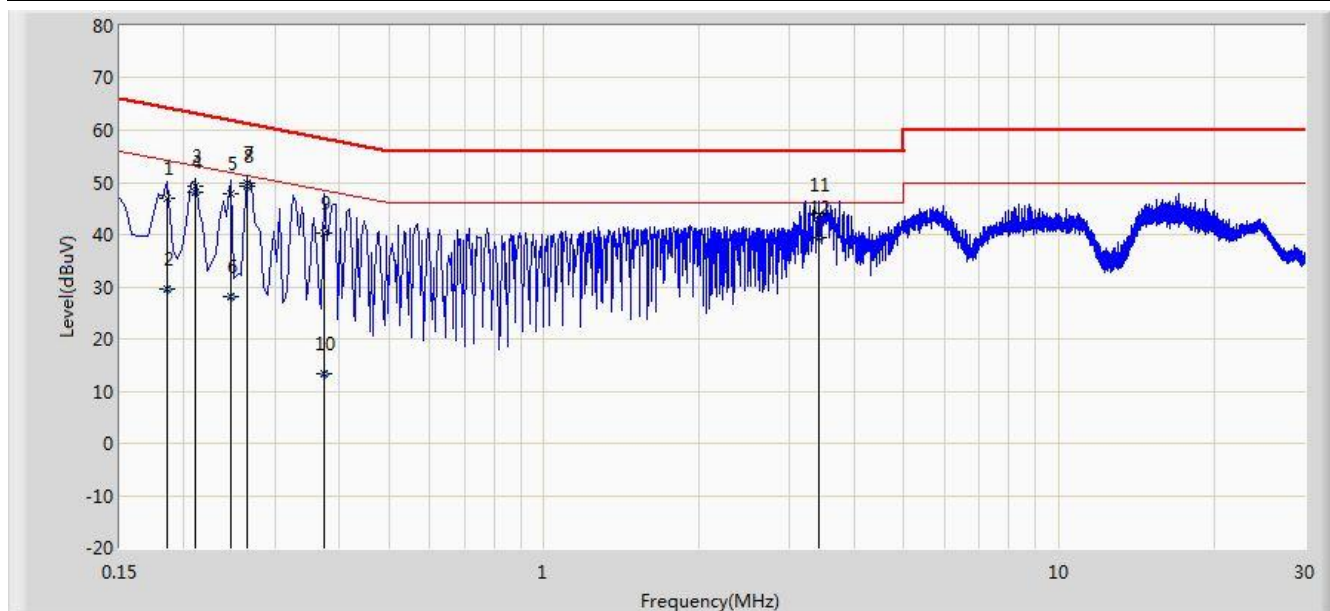

No	Flag	Mark	Frequency (MHz)	Measure Level (dBuV)	Reading Level (dBuV)	Over Limit (dB)	Limit (dBuV)	Factor (dB)	Type
1			0.186	47.051	37.016	-17.162	64.213	10.035	QP
2			0.186	29.500	19.464	-24.714	54.213	10.035	AV
3		*	0.210	49.244	39.250	-13.961	63.205	9.995	QP
4			0.210	48.122	38.128	-5.083	53.205	9.995	AV
5			0.246	47.706	37.708	-14.185	61.891	9.998	QP
6			0.246	28.218	18.220	-23.674	51.891	9.998	AV
7			0.266	49.771	39.758	-11.471	61.242	10.013	QP
8			0.266	49.155	39.142	-2.087	51.242	10.013	AV
9			0.374	40.313	30.220	-18.098	58.412	10.093	QP
10			0.374	13.310	3.217	-35.102	48.412	10.093	AV
11			3.418	43.902	33.994	-12.098	56.000	9.907	QP
12			3.418	39.552	29.644	-6.448	46.000	9.907	AV

Note: Measure Level (dB μ V) = Reading Level (dB μ V) + Factor (dB)

Factor (dB) = Cable Loss (dB) + LISN Factor (dB)

8. CONCLUSION

The data collected relate only the item(s) tested and show that the **WIFI dual band 4 GE LAN GPON HGU FCC ID: 2ABLK-8X4G-2** is in compliance with Part 15E of the FCC Rules.

The End