

Engineer: Roy Cheng	
Site: AC1	Time: 2014/07/27 - 13:42
Limit: FCC_Part15.209_RE(3m)	Margin: 0
Probe: FMZB1519_0.009-30MHz	Polarity: Face On
EUT: WIFI dual band 4 GE LAN GPON HGU	Power: AC 120V/60Hz
Note: There is the ambient noise within frequency range 9kHz~30MHz.	

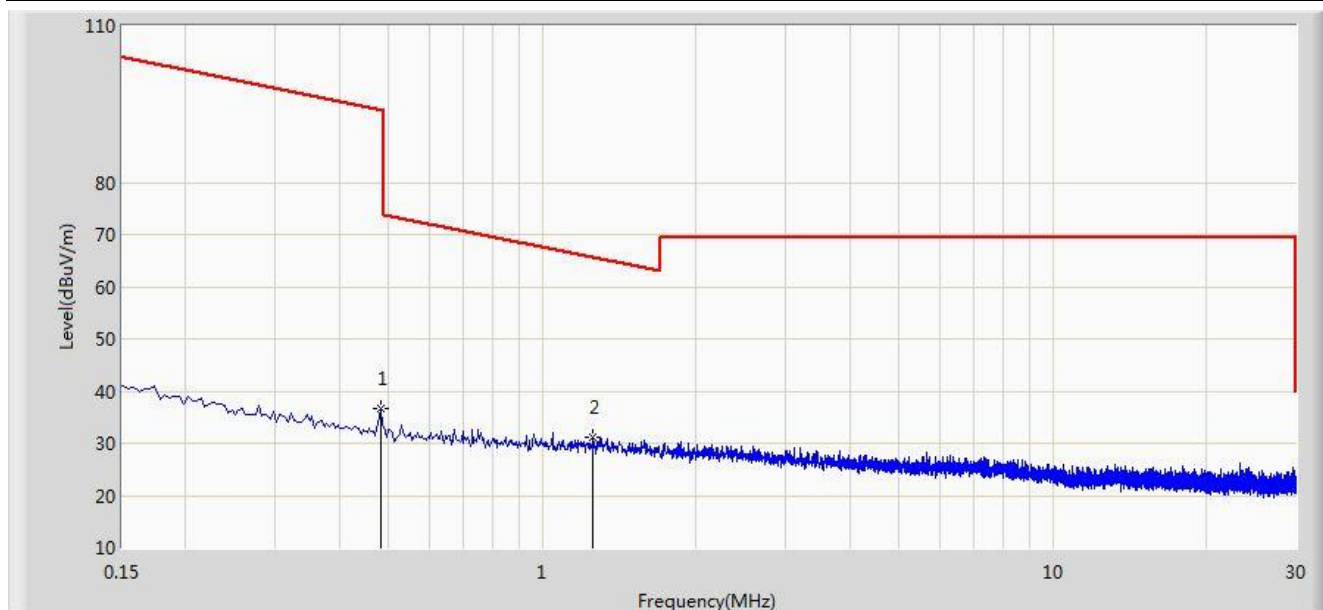

No	Flag	Mark	Frequency (MHz)	Measure Level (dBuV/m)	Reading Level (dBuV)	Over Limit (dB)	Limit (dBuV/m)	Factor (dB)	Type
1			0.482	36.594	16.194	-57.348	93.943	20.401	QP
2		*	1.258	31.288	10.788	-34.345	65.633	20.500	QP

Note: Measure Level (dBμV/m) = Reading Level (dBμV) + Factor (dB)

Factor (dB) = Cable Loss (dB) + Antenna Factor (dB/m)

Engineer: Roy Cheng	
Site: AC1	Time: 2014/07/27 - 12:31
Limit: FCC_Part15.209_RE(1m)	Margin: 0
Probe: BBHA9170_18-40GHz	Polarity: Horizontal
EUT: WIFI dual band 4 GE LAN GPON HGU	Power: AC 120V/60Hz
Note: There is the ambient noise within frequency range 18GHz~40GHz.	



No	Flag	Mark	Frequency (MHz)	Measure Level (dBuV/m)	Reading Level (dBuV)	Over Limit (dB)	Limit (dBuV/m)	Factor (dB)	Type
1			33179.678	48.619	27.098	-14.881	63.500	21.521	AV
2			33180.000	61.501	39.980	-21.999	83.500	21.521	PK
3			38790.000	72.332	44.416	-11.168	83.500	27.916	PK
4			38790.560	59.594	31.678	-3.906	63.500	27.916	AV

Note: Measure Level (dB μ V/m) = Reading Level (dB μ V) + Factor (dB)

Factor (dB) = Cable Loss (dB) + Antenna Factor (dB/m) - Pre_Amplifier Gain (dB)

Engineer: Roy Cheng	
Site: AC1	Time: 2014/07/27 - 12:31
Limit: FCC_Part15.209_RE(1m)	Margin: 0
Probe: BBHA9170_18-40GHz	Polarity: Vertical
EUT: WIFI dual band 4 GE LAN GPON HGU	Power: AC 120V/60Hz
Note: There is the ambient noise within frequency range 18GHz~40GHz.	



No	Flag	Mark	Frequency (MHz)	Measure Level (dBuV/m)	Reading Level (dBuV)	Over Limit (dB)	Limit (dBuV/m)	Factor (dB)	Type
1			33212.889	49.517	27.980	-13.983	63.500	21.537	AV
2			33213.000	62.169	40.632	-21.331	83.500	21.538	PK
3			38118.567	58.968	32.567	-4.532	63.500	26.402	AV
4			38119.000	71.963	45.561	-11.537	83.500	26.403	PK

Note: Measure Level (dB μ V/m) = Reading Level (dB μ V) + Factor (dB)

Factor (dB) = Cable Loss (dB) + Antenna Factor (dB/m) - Pre_Amplifier Gain (dB)

7.9. Radiated Restricted Band Edge Measurement

7.9.1. Test Limit

For 15.205 requirement:

Radiated emissions which fall in the restricted bands, as defined in Section 15.205(a) of FCC part 15, must also comply with the radiated emission limits specified in Section 15.209(a).

MHz	MHz	MHz	GHz
0.090 - 0.110	16.42 - 16.423	399.9 - 410	4.5 - 5.15
¹ 0.495 - 0.505	16.69475 - 16.69525	608 - 614	5.35 - 5.46
2.1735 - 2.1905	16.80425 - 16.80475	960 - 1240	7.25 - 7.75
4.125 - 4.128	25.5 - 25.67	1300 - 1427	8.025 - 8.5
4.17725 - 4.17775	37.5 - 38.25	1435 - 1626.5	9.0 - 9.2
4.20725 - 4.20775	73 - 74.6	1645.5 - 1646.5	9.3 - 9.5
6.215 - 6.218	74.8 - 75.2	1660 - 1710	10.6 - 12.7
6.26775 - 6.26825	108 - 121.94	1718.8 - 1722.2	13.25 - 13.4
6.31175 - 6.31225	123 - 138	2200 - 2300	14.47 - 14.5
8.291 - 8.294	149.9 - 150.05	2310 - 2390	15.35 - 16.2
8.362 - 8.366	156.52475 - 156.52525	2483.5 - 2500	17.7 - 21.4
8.37625 - 8.38675	156.7 - 156.9	2690 - 2900	22.01 - 23.12
8.41425 - 8.41475	162.0125 - 167.17	3260 - 3267	23.6 - 24.0
12.29 - 12.293	167.72 - 173.2	3332 - 3339	31.2 - 31.8
12.51975 - 12.52025	240 - 285	3345.8 - 3358	36.43 - 36.5
12.57675 - 12.57725	322 - 335.4	3600 - 4400	(²)

For 15.407(b) requirement:

For transmitters operating in the 5.15-5.25 GHz band: All emissions outside of the 5.15-5.35 GHz band shall not exceed an e.i.r.p. of -27dBm/MHz.

For transmitters operating in the 5.25-5.35 GHz band: All emissions outside of the 5.15-5.35 GHz band shall not exceed an e.i.r.p. of -27dBm/MHz.

For transmitters operating in the 5.47-5.725 GHz band: All emissions outside of the 5.47-5.725 GHz band shall not exceed an e.i.r.p. of -27dBm/MHz.

For transmitters operating in the 5.725-5.85 GHz band: All emissions within the frequency range from the band edge to 10 MHz above or below the band edge shall not exceed an e.i.r.p. of -17dBm/MHz; for frequencies 10 MHz or greater above or below the band edge, emissions shall not exceed an e.i.r.p. of -27dBm/MHz.

Operating Frequency Band (MHz)	EIRP Limit (dBm/MHz)	Equivalent Field Strength at 3m (dBuV/m)
5150 - 5350	-27	68.2
5470 - 5725	-27	68.2
5725 - 5850	-17	78.2
	-27	68.2

Note: Refer to KDB 789033 D01v01r04 G)2)c), as specified in § 15.407(b), emissions above 1000 MHz that are outside of the restricted bands are subject to a maximum emission limit of -27 dBm/MHz (or -17 dBm/MHz as specified in § 15.407(b)(4)). However, an out-of-band emission that complies with both the peak and average limits of § 15.209 is not required to satisfy the -27 dBm/MHz or -17 dBm/MHz maximum emission limit.

All out of band emissions appearing in a restricted band as specified in Section 15.205 of the Title 47 CFR must not exceed the limits shown in Table per Section 15.209.

FCC Part 15 Subpart C Paragraph 15.209		
Frequency [MHz]	Field Strength [V/m]	Measured Distance [Meters]
0.009 – 0.490	2400/F (kHz)	300
0.490 – 1.705	24000/F (kHz)	30
1.705 - 30	30	30
30 - 88	100	3
88 - 216	150	3
216 - 960	200	3
Above 960	500	3

7.9.2. Test Result of Radiated Restricted Band Edge

Engineer: Roy Cheng	
Site: AC1	Time: 2014/07/15 - 19:25
Limit: FCC_Part15.209_RE(3m)	Margin: 0
Probe: BBHA9120D_1-18GHz	Polarity: Horizontal
EUT: WIFI dual band 4 GE LAN GPON HGU	Power: AC 120V/60Hz
Note: Mode 1: Transmit by 802.11a at channel 5180MHz Ant 0+1+2+3	

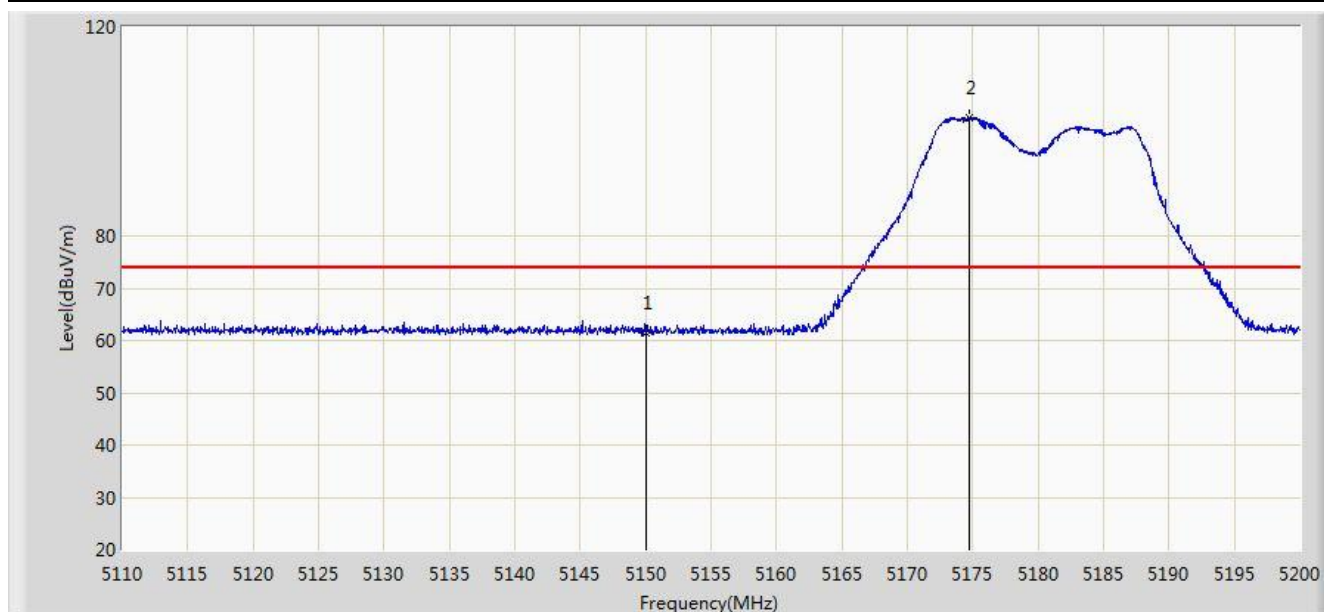

No	Flag	Mark	Frequency (MHz)	Measure Level (dBuV/m)	Reading Level (dBuV)	Over Limit (dB)	Limit (dBuV/m)	Factor (dB)	Type
1			5150.000	61.490	24.738	-12.510	74.000	36.752	PK
2		*	5174.755	102.612	65.930	N/A	N/A	36.682	PK

Note: Measure Level (dB μ V/m) = Reading Level (dB μ V) + Factor (dB)

Factor (dB) = Cable Loss (dB) + Antenna Factor (dB/m).

Engineer: Roy Cheng	
Site: AC1	Time: 2014/07/15 - 19:30
Limit: FCC_Part15.209_RE(3m)	Margin: 0
Probe: BBHA9120D_1-18GHz	Polarity: Horizontal
EUT: WIFI dual band 4 GE LAN GPON HGU	Power: AC 120V/60Hz
Note: Mode 1: Transmit by 802.11a at channel 5180MHz Ant 0+1+2+3	

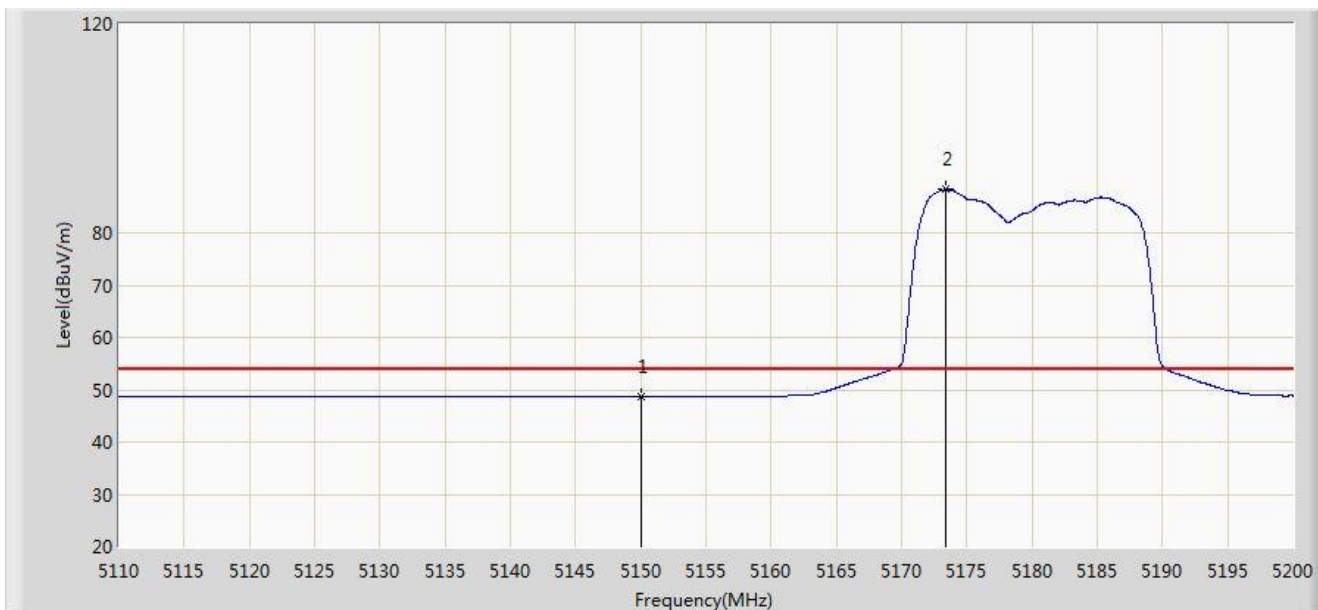

No	Flag	Mark	Frequency (MHz)	Measure Level (dBuV/m)	Reading Level (dBuV)	Over Limit (dB)	Limit (dBuV/m)	Factor (dB)	Type
1			5150.000	48.779	12.027	-5.221	54.000	36.752	AV
2		*	5173.360	88.318	51.632	N/A	N/A	36.686	AV

Note: Measure Level (dB μ V/m) = Reading Level (dB μ V) + Factor (dB)

Factor (dB) = Cable Loss (dB) + Antenna Factor (dB/m).

Engineer: Roy Cheng	
Site: AC1	Time: 2014/07/15 - 19:32
Limit: FCC_Part15.209_RE(3m)	Margin: 0
Probe: BBHA9120D_1-18GHz	Polarity: Vertical
EUT: WIFI dual band 4 GE LAN GPON HGU	Power: AC 120V/60Hz
Note: Mode 1: Transmit by 802.11a at channel 5180MHz Ant 0+1+2+3	

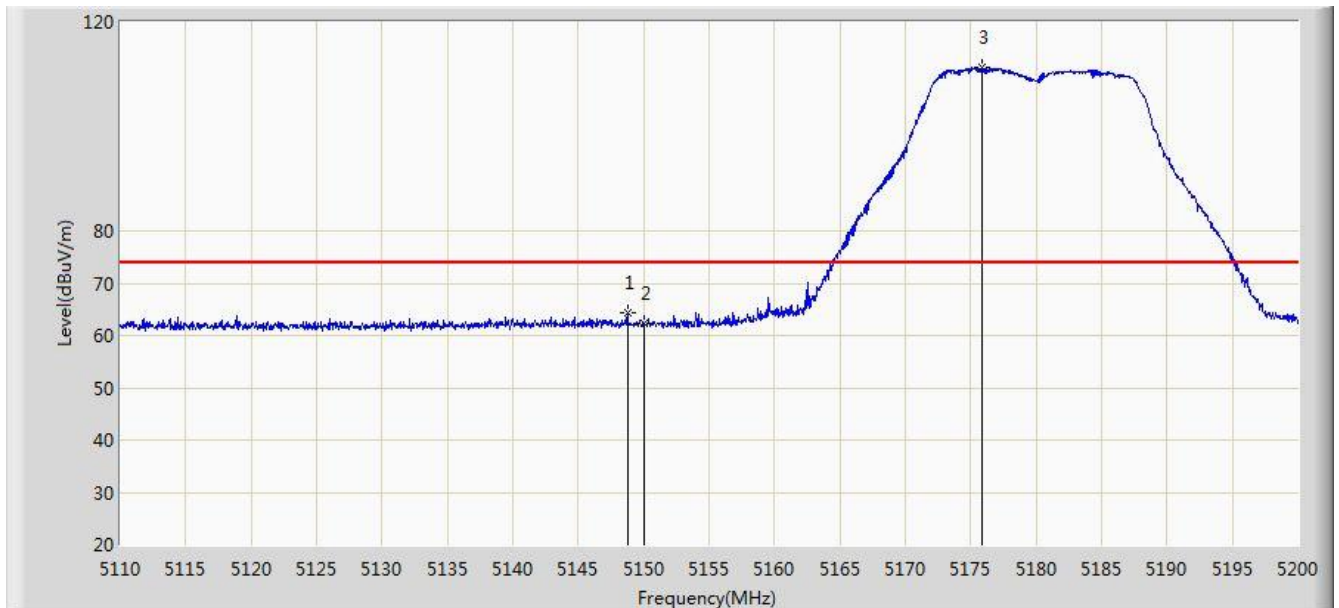

No	Flag	Mark	Frequency (MHz)	Measure Level (dBuV/m)	Reading Level (dBuV)	Over Limit (dB)	Limit (dBuV/m)	Factor (dB)	Type
1			5148.745	64.212	27.458	-9.788	74.000	36.754	PK
2			5150.000	62.384	25.632	-11.616	74.000	36.752	PK
3		*	5175.835	111.195	74.516	N/A	N/A	36.678	PK

Note: Measure Level (dBuV/m) = Reading Level (dBuV) + Factor (dB)

Factor (dB) = Cable Loss (dB) + Antenna Factor (dB/m).

Engineer: Roy Cheng	
Site: AC1	Time: 2014/07/15 - 19:36
Limit: FCC_Part15.209_RE(3m)	Margin: 0
Probe: BBHA9120D_1-18GHz	Polarity: Vertical
EUT: WIFI dual band 4 GE LAN GPON HGU	Power: AC 120V/60Hz
Note: Mode 1: Transmit by 802.11a at channel 5180MHz Ant 0+1+2+3	

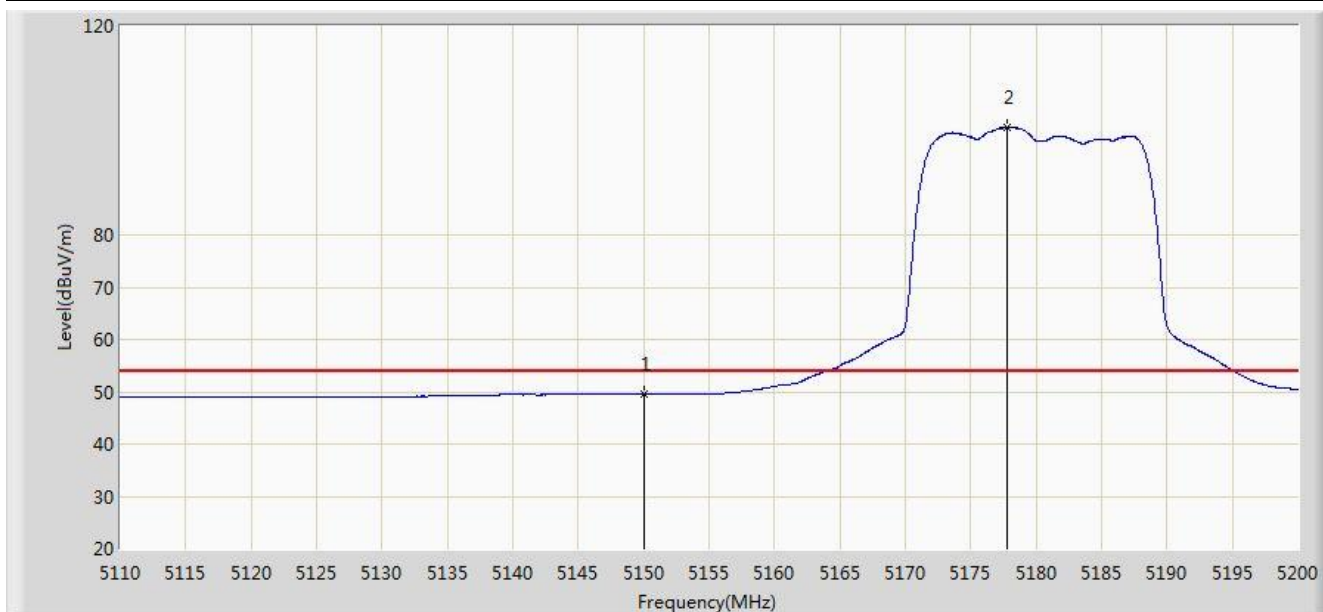

No	Flag	Mark	Frequency (MHz)	Measure Level (dBuV/m)	Reading Level (dBuV)	Over Limit (dB)	Limit (dBuV/m)	Factor (dB)	Type
1			5150.000	49.480	12.728	-4.520	54.000	36.752	AV
2		*	5177.815	100.604	63.932	N/A	N/A	36.673	AV

Note: Measure Level (dB μ V/m) = Reading Level (dB μ V) + Factor (dB)

Factor (dB) = Cable Loss (dB) + Antenna Factor (dB/m).

Engineer: Roy Cheng	
Site: AC1	Time: 2014/07/15 - 20:16
Limit: FCC_Part15.209_RE(3m)	Margin: 0
Probe: BBHA9120D_1-18GHz	Polarity: Horizontal
EUT: WIFI dual band 4 GE LAN GPON HGU	Power: AC 120V/60Hz
Note: Mode 2: Transmit by 802.11n20 at channel 5180MHz Ant 0+1+2+3	

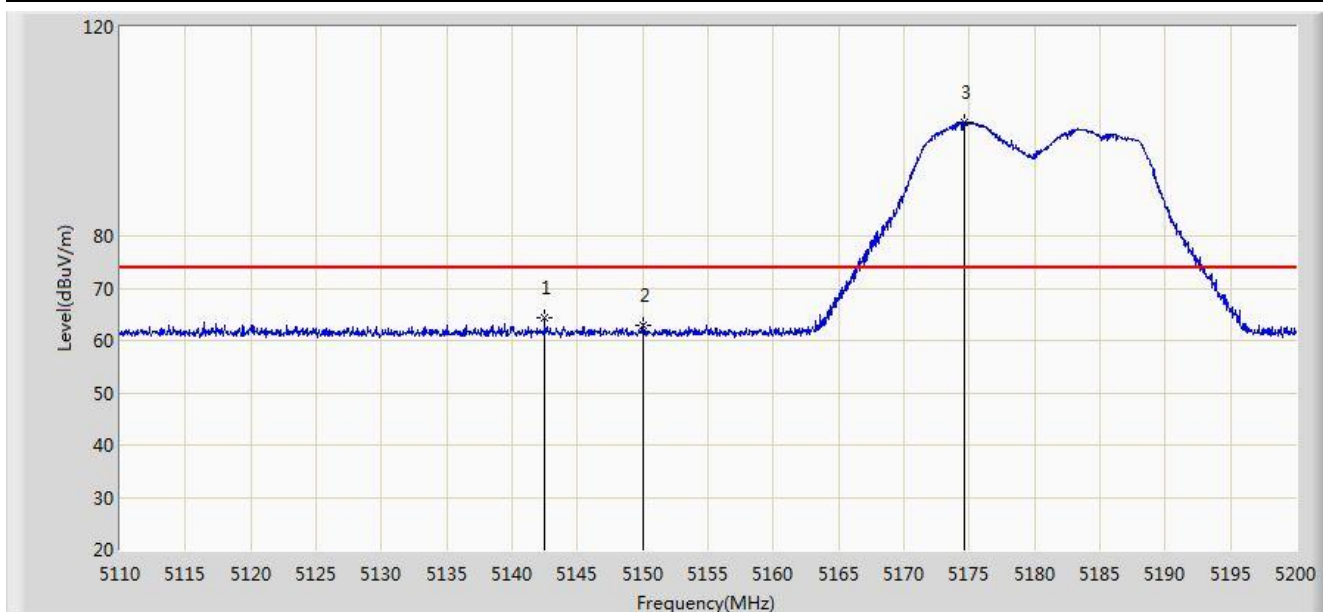

No	Flag	Mark	Frequency (MHz)	Measure Level (dBuV/m)	Reading Level (dBuV)	Over Limit (dB)	Limit (dBuV/m)	Factor (dB)	Type
1			5142.490	64.393	27.630	-9.607	74.000	36.763	PK
2			5150.000	62.934	26.182	-11.066	74.000	36.752	PK
3		*	5174.575	101.842	65.159	N/A	N/A	36.683	PK

Note: Measure Level (dBuV/m) = Reading Level (dBuV) + Factor (dB)

Factor (dB) = Cable Loss (dB) + Antenna Factor (dB/m).

Engineer: Roy Cheng	
Site: AC1	Time: 2014/07/15 - 20:19
Limit: FCC_Part15.209_RE(3m)	Margin: 0
Probe: BBHA9120D_1-18GHz	Polarity: Horizontal
EUT: WIFI dual band 4 GE LAN GPON HGU	Power: AC 120V/60Hz
Note: Mode 2: Transmit by 802.11n20 at channel 5180MHz Ant 0+1+2+3	

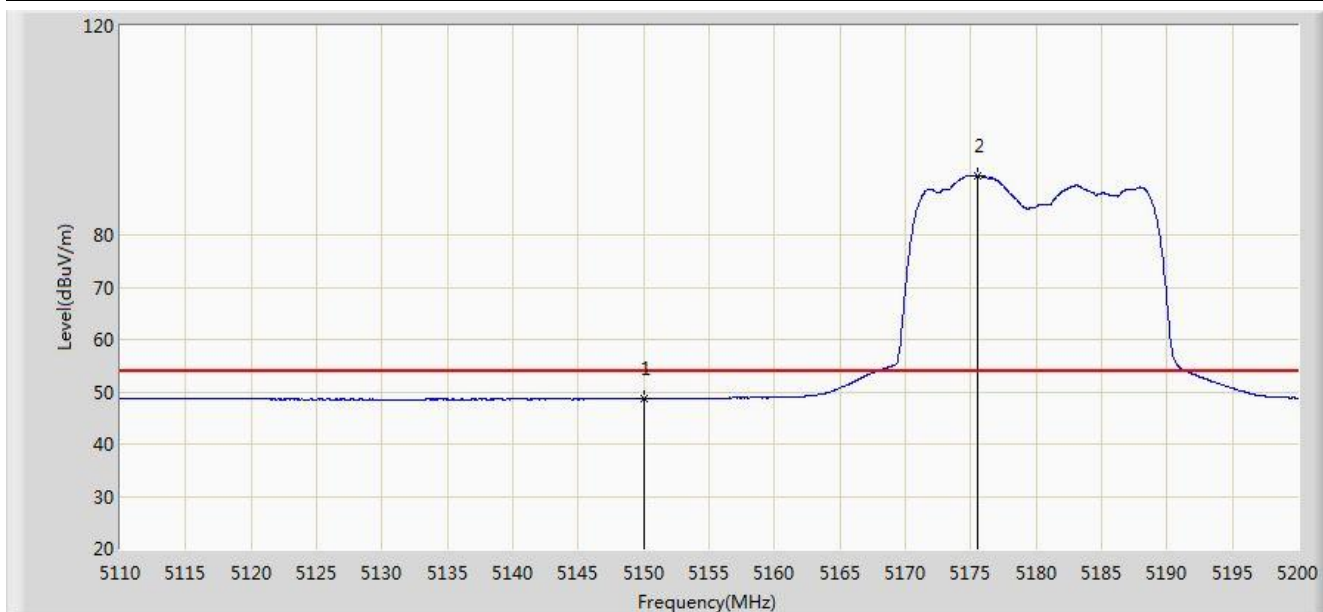

No	Flag	Mark	Frequency (MHz)	Measure Level (dBuV/m)	Reading Level (dBuV)	Over Limit (dB)	Limit (dBuV/m)	Factor (dB)	Type
1			5150.000	48.605	11.853	-5.395	54.000	36.752	AV
2		*	5175.475	91.292	54.612	N/A	N/A	36.680	AV

Note: Measure Level (dB μ V/m) = Reading Level (dB μ V) + Factor (dB)

Factor (dB) = Cable Loss (dB) + Antenna Factor (dB/m).

Engineer: Roy Cheng	
Site: AC1	Time: 2014/07/15 - 20:24
Limit: FCC_Part15.209_RE(3m)	Margin: 0
Probe: BBHA9120D_1-18GHz	Polarity: Vertical
EUT: WIFI dual band 4 GE LAN GPON HGU	Power: AC 120V/60Hz
Note: Mode 2: Transmit by 802.11n20 at channel 5180MHz Ant 0+1+2+3	

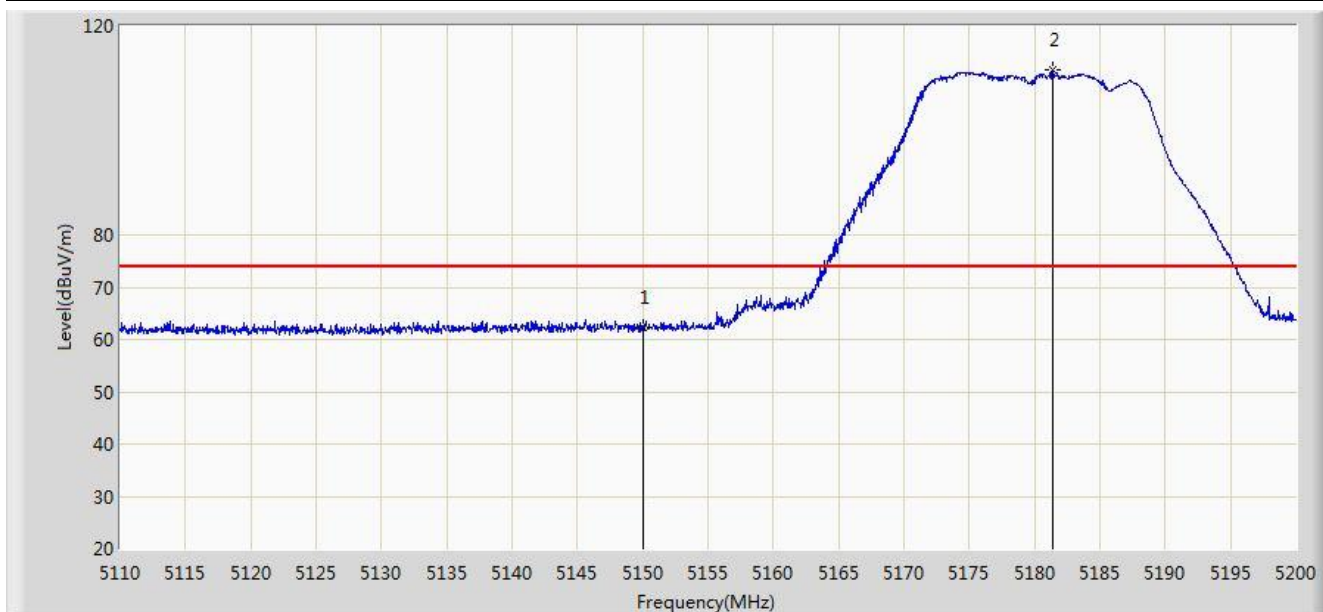

No	Flag	Mark	Frequency (MHz)	Measure Level (dBuV/m)	Reading Level (dBuV)	Over Limit (dB)	Limit (dBuV/m)	Factor (dB)	Type
1			5150.000	62.359	25.607	-11.641	74.000	36.752	PK
2		*	5181.415	111.600	74.939	N/A	N/A	36.661	PK

Note: Measure Level (dB μ V/m) = Reading Level (dB μ V) + Factor (dB)

Factor (dB) = Cable Loss (dB) + Antenna Factor (dB/m).

Engineer: Roy Cheng	
Site: AC1	Time: 2014/07/15 - 20:26
Limit: FCC_Part15.209_RE(3m)	Margin: 0
Probe: BBHA9120D_1-18GHz	Polarity: Vertical
EUT: WIFI dual band 4 GE LAN GPON HGU	Power: AC 120V/60Hz
Note: Mode 2: Transmit by 802.11n20 at channel 5180MHz Ant 0+1+2+3	

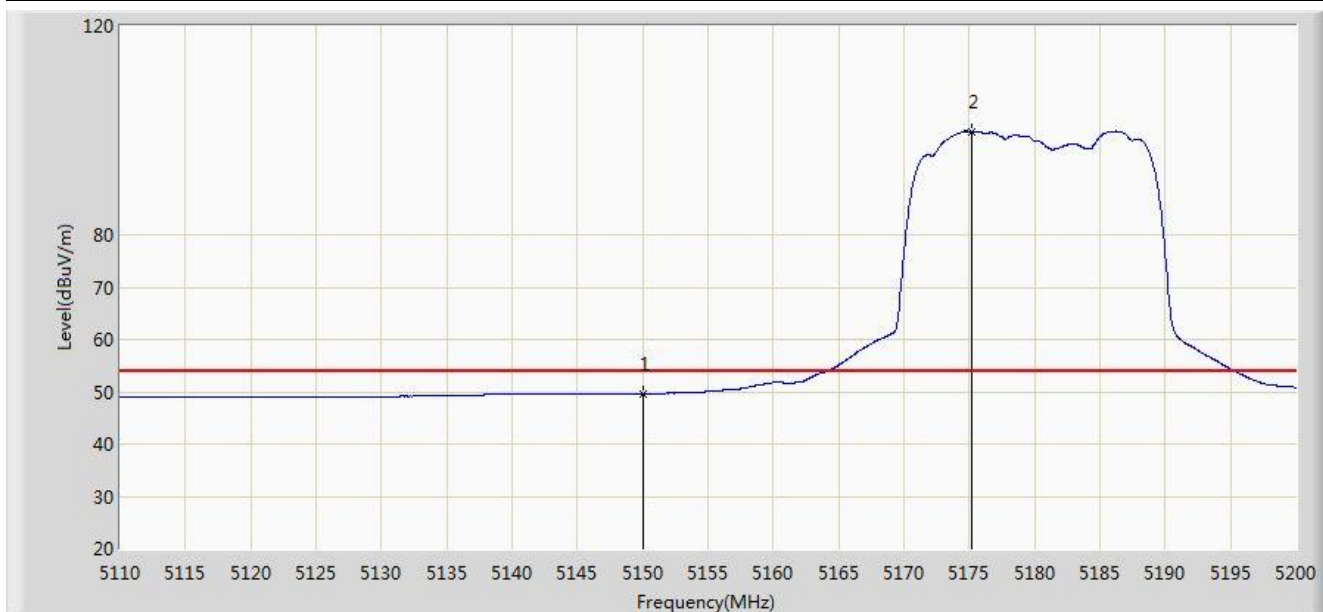

No	Flag	Mark	Frequency (MHz)	Measure Level (dBuV/m)	Reading Level (dBuV)	Over Limit (dB)	Limit (dBuV/m)	Factor (dB)	Type
1			5150.000	49.632	12.880	-4.368	54.000	36.752	AV
2		*	5175.160	99.707	63.026	N/A	N/A	36.681	AV

Note: Measure Level (dB μ V/m) = Reading Level (dB μ V) + Factor (dB)

Factor (dB) = Cable Loss (dB) + Antenna Factor (dB/m).

Engineer: Roy Cheng	
Site: AC1	Time: 2014/07/15 - 21:51
Limit: FCC_Part15.209_RE(3m)	Margin: 0
Probe: BBHA9120D_1-18GHz	Polarity: Horizontal
EUT: WIFI dual band 4 GE LAN GPON HGU	Power: AC 120V/60Hz
Note: Mode 3: Transmit by 802.11ac20 at channel 5180MHz Ant 0+1+2+3	

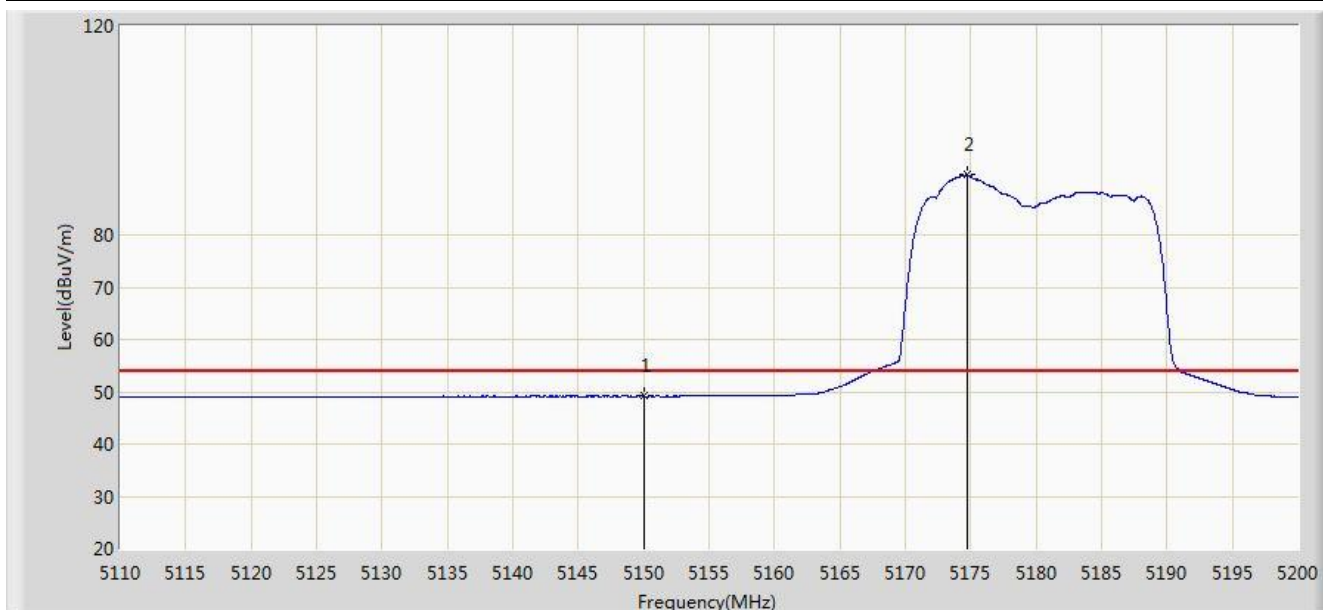

No	Flag	Mark	Frequency (MHz)	Measure Level (dBuV/m)	Reading Level (dBuV)	Over Limit (dB)	Limit (dBuV/m)	Factor (dB)	Type
1			5150.000	49.132	12.380	-4.868	54.000	36.752	AV
2		*	5174.755	91.454	54.772	N/A	N/A	36.682	AV

Note: Measure Level (dB μ V/m) = Reading Level (dB μ V) + Factor (dB)

Factor (dB) = Cable Loss (dB) + Antenna Factor (dB/m).

Engineer: Roy Cheng	
Site: AC1	Time: 2014/07/15 - 21:54
Limit: FCC_Part15.209_RE(3m)	Margin: 0
Probe: BBHA9120D_1-18GHz	Polarity: Vertical
EUT: WIFI dual band 4 GE LAN GPON HGU	Power: AC 120V/60Hz
Note: Mode 3: Transmit by 802.11ac20 at channel 5180MHz Ant 0+1+2+3	

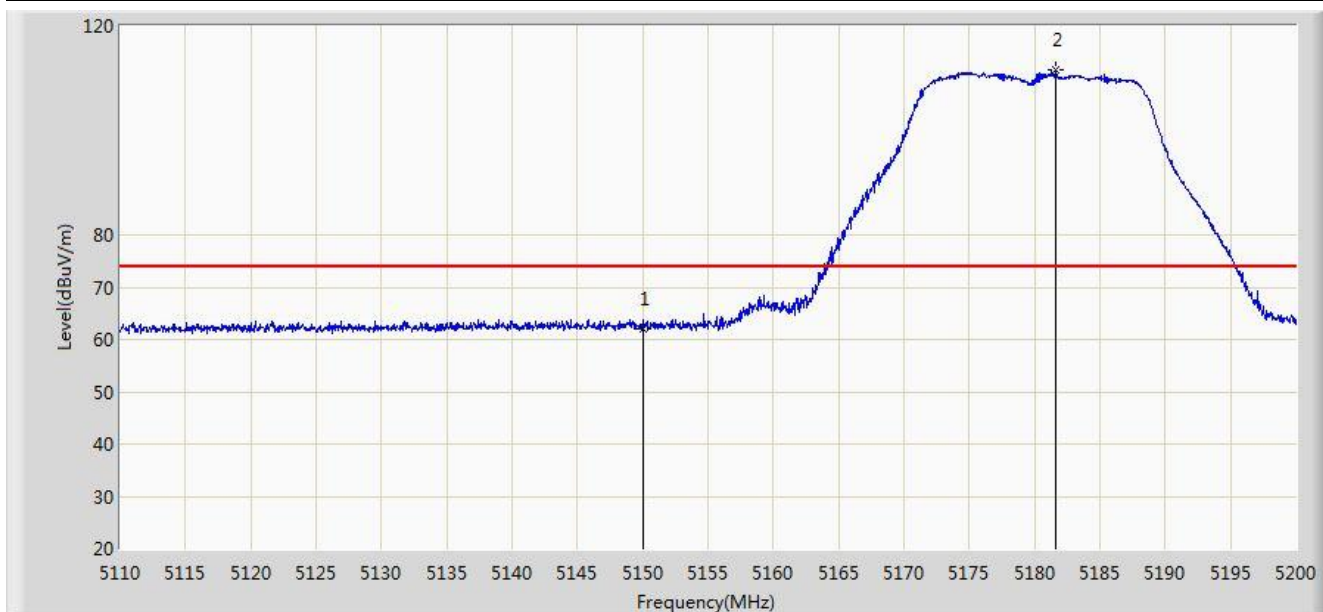

No	Flag	Mark	Frequency (MHz)	Measure Level (dBuV/m)	Reading Level (dBuV)	Over Limit (dB)	Limit (dBuV/m)	Factor (dB)	Type
1			5150.000	62.029	25.277	-11.971	74.000	36.752	PK
2		*	5181.595	111.603	74.943	N/A	N/A	36.661	PK

Note: Measure Level (dB μ V/m) = Reading Level (dB μ V) + Factor (dB)

Factor (dB) = Cable Loss (dB) + Antenna Factor (dB/m).

Engineer: Roy Cheng	
Site: AC1	Time: 2014/07/15 - 21:56
Limit: FCC_Part15.209_RE(3m)	Margin: 0
Probe: BBHA9120D_1-18GHz	Polarity: Vertical
EUT: WIFI dual band 4 GE LAN GPON HGU	Power: AC 120V/60Hz
Note: Mode 3: Transmit by 802.11ac20 at channel 5180MHz Ant 0+1+2+3	

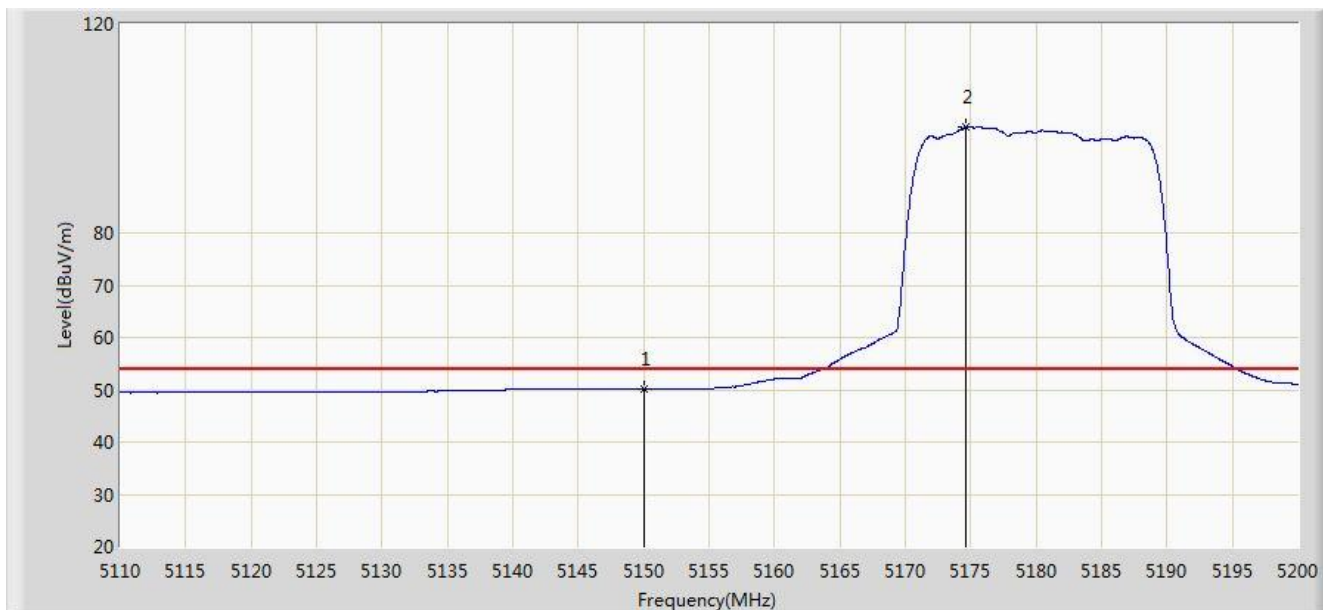

No	Flag	Mark	Frequency (MHz)	Measure Level (dBuV/m)	Reading Level (dBuV)	Over Limit (dB)	Limit (dBuV/m)	Factor (dB)	Type
1			5150.000	50.031	13.279	-3.969	54.000	36.752	AV
2		*	5174.665	100.288	63.606	N/A	N/A	36.682	AV

Note: Measure Level (dB μ V/m) = Reading Level (dB μ V) + Factor (dB)

Factor (dB) = Cable Loss (dB) + Antenna Factor (dB/m).

Engineer: Roy Cheng	
Site: AC1	Time: 2014/07/15 - 22:38
Limit: FCC_Part15.209_RE(3m)	Margin: 0
Probe: BBHA9120D_1-18GHz	Polarity: Horizontal
EUT: WIFI dual band 4 GE LAN GPON HGU	Power: AC 120V/60Hz
Note: Mode 4: Transmit by 802.11n40 at channel 5190MHz Ant 0+1+2+3	

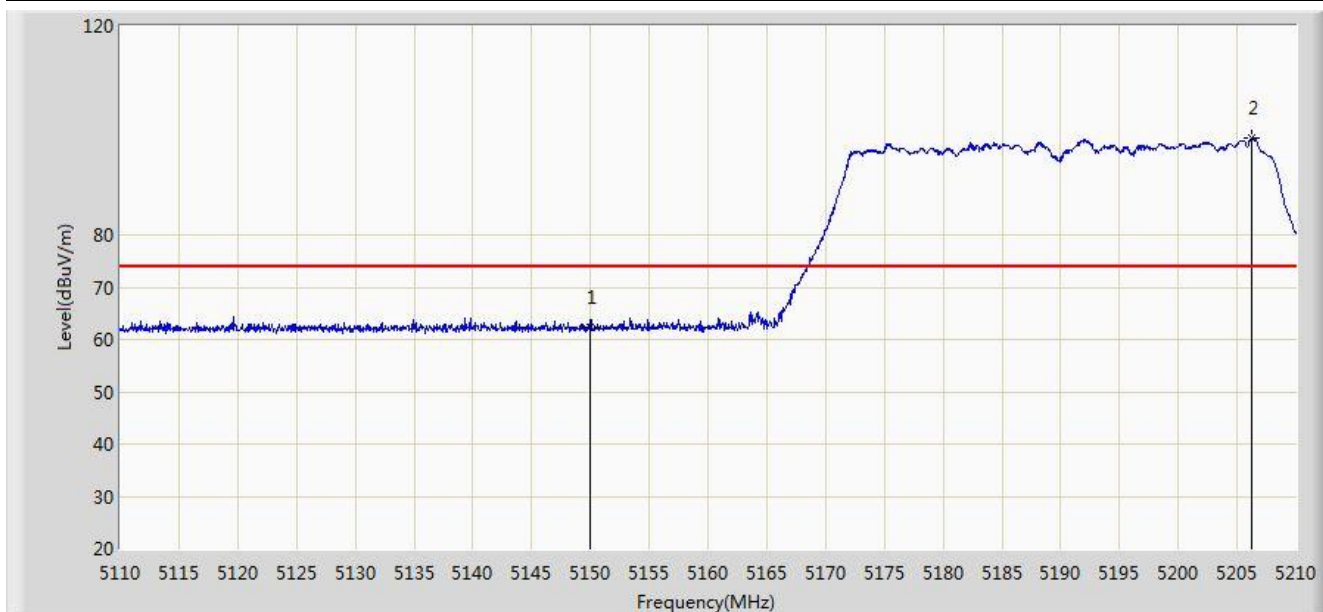

No	Flag	Mark	Frequency (MHz)	Measure Level (dBuV/m)	Reading Level (dBuV)	Over Limit (dB)	Limit (dBuV/m)	Factor (dB)	Type
1			5150.000	62.304	25.552	-11.696	74.000	36.752	PK
2		*	5206.250	98.458	61.858	N/A	N/A	36.600	PK

Note: Measure Level (dB μ V/m) = Reading Level (dB μ V) + Factor (dB)

Factor (dB) = Cable Loss (dB) + Antenna Factor (dB/m).

Engineer: Roy Cheng	
Site: AC1	Time: 2014/07/15 - 22:49
Limit: FCC_Part15.209_RE(3m)	Margin: 0
Probe: BBHA9120D_1-18GHz	Polarity: Horizontal
EUT: WIFI dual band 4 GE LAN GPON HGU	Power: AC 120V/60Hz
Note: Mode 4: Transmit by 802.11n40 at channel 5190MHz Ant 0+1+2+3	

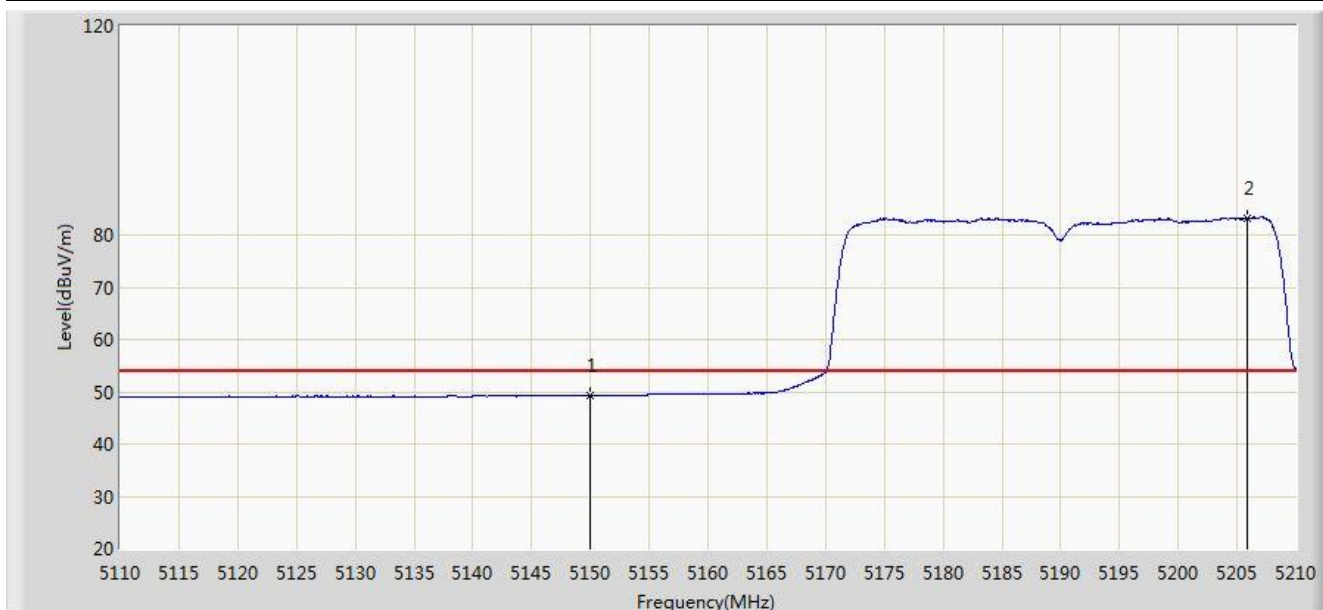

No	Flag	Mark	Frequency (MHz)	Measure Level (dBuV/m)	Reading Level (dBuV)	Over Limit (dB)	Limit (dBuV/m)	Factor (dB)	Type
1			5150.000	49.335	12.583	-4.665	54.000	36.752	AV
2		*	5205.900	83.208	46.607	N/A	N/A	36.601	AV

Note: Measure Level (dB μ V/m) = Reading Level (dB μ V) + Factor (dB)

Factor (dB) = Cable Loss (dB) + Antenna Factor (dB/m).

Engineer: Roy Cheng	
Site: AC1	Time: 2014/07/15 - 22:49
Limit: FCC_Part15.209_RE(3m)	Margin: 0
Probe: BBHA9120D_1-18GHz	Polarity: Vertical
EUT: WIFI dual band 4 GE LAN GPON HGU	Power: AC 120V/60Hz
Note: Mode 4: Transmit by 802.11n40 at channel 5190MHz Ant 0+1+2+3	

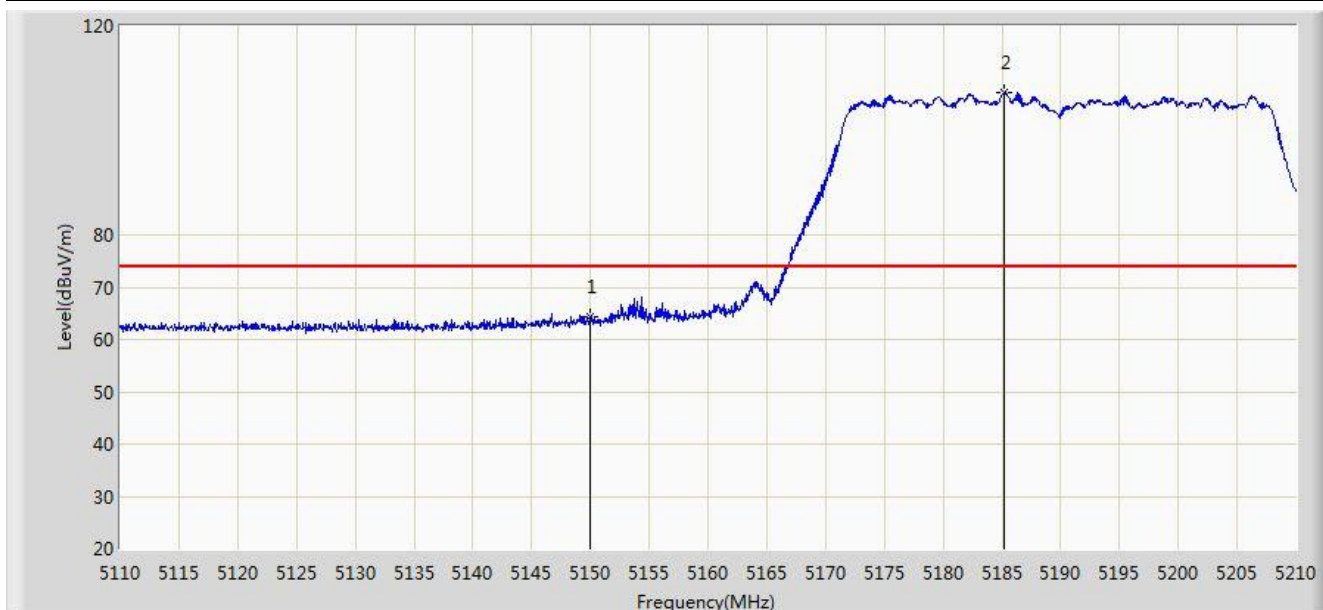

No	Flag	Mark	Frequency (MHz)	Measure Level (dBuV/m)	Reading Level (dBuV)	Over Limit (dB)	Limit (dBuV/m)	Factor (dB)	Type
1			5150.000	64.219	27.467	-9.781	74.000	36.752	PK
2		*	5185.150	107.177	70.526	N/A	N/A	36.650	PK

Note: Measure Level (dB μ V/m) = Reading Level (dB μ V) + Factor (dB)

Factor (dB) = Cable Loss (dB) + Antenna Factor (dB/m).

Engineer: Roy Cheng	
Site: AC1	Time: 2014/07/15 - 22:51
Limit: FCC_Part15.209_RE(3m)	Margin: 0
Probe: BBHA9120D_1-18GHz	Polarity: Vertical
EUT: WIFI dual band 4 GE LAN GPON HGU	Power: AC 120V/60Hz
Note: Mode 4: Transmit by 802.11n40 at channel 5190MHz Ant 0+1+2+3	

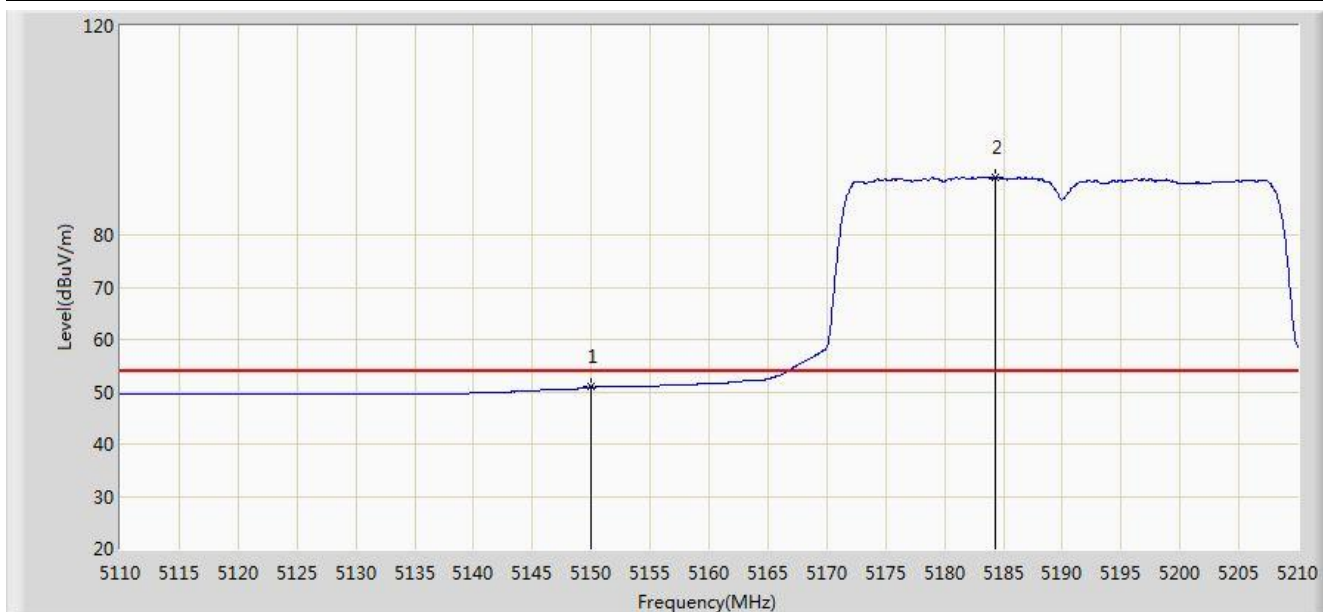

No	Flag	Mark	Frequency (MHz)	Measure Level (dBuV/m)	Reading Level (dBuV)	Over Limit (dB)	Limit (dBuV/m)	Factor (dB)	Type
1			5150.000	50.895	14.143	-3.105	54.000	36.752	AV
2		*	5184.300	91.081	54.428	N/A	N/A	36.653	AV

Note: Measure Level (dB μ V/m) = Reading Level (dB μ V) + Factor (dB)

Factor (dB) = Cable Loss (dB) + Antenna Factor (dB/m).

Engineer: Roy Cheng	
Site: AC1	Time: 2014/07/18 - 15:04
Limit: FCC_Part15.209_RE(3m)	Margin: 0
Probe: BBHA9120D_1-18GHz	Polarity: Horizontal
EUT: WIFI dual band 4 GE LAN GPON HGU	Power: AC 120V/60Hz
Note: Mode 5: Transmit by 802.11ac40 at channel 5190MHz Ant 0+1+2+3	

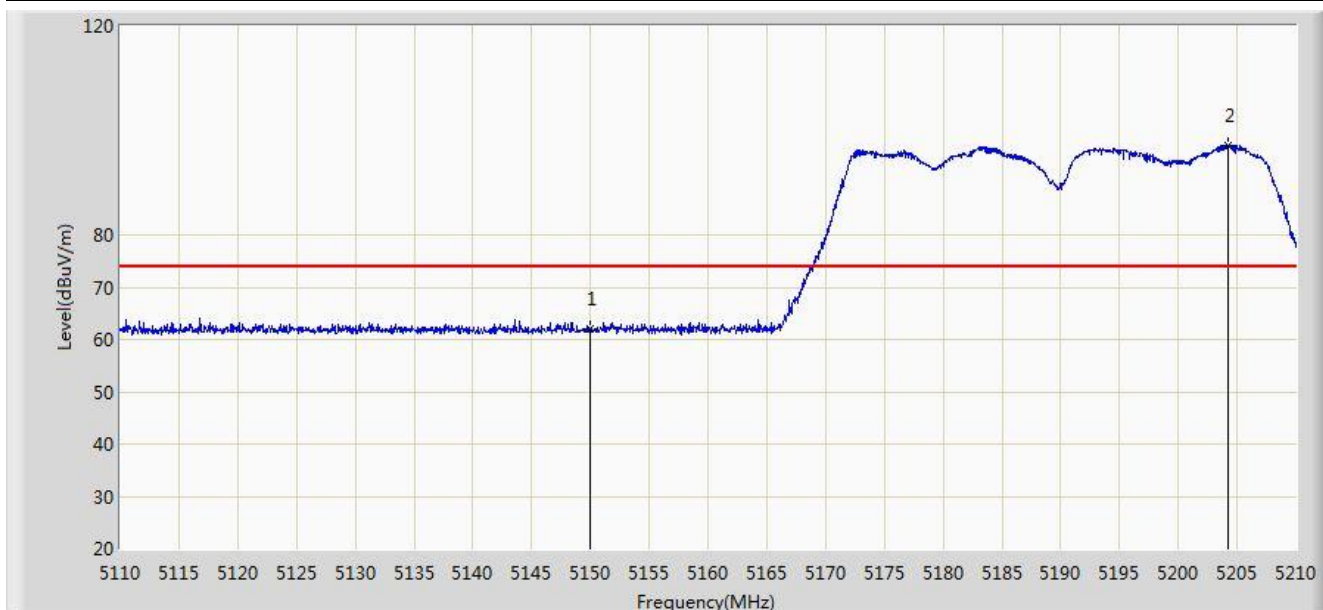

No	Flag	Mark	Frequency (MHz)	Measure Level (dBuV/m)	Reading Level (dBuV)	Over Limit (dB)	Limit (dBuV/m)	Factor (dB)	Type
1			5150.000	61.992	25.240	-12.008	74.000	36.752	PK
2		*	5204.200	97.206	60.602	N/A	N/A	36.604	PK

Note: Measure Level (dB μ V/m) = Reading Level (dB μ V) + Factor (dB)

Factor (dB) = Cable Loss (dB) + Antenna Factor (dB/m).

Engineer: Roy Cheng	
Site: AC1	Time: 2014/07/18 - 15:10
Limit: FCC_Part15.209_RE(3m)	Margin: 0
Probe: BBHA9120D_1-18GHz	Polarity: Horizontal
EUT: WIFI dual band 4 GE LAN GPON HGU	Power: AC 120V/60Hz
Note: Mode 5: Transmit by 802.11ac40 at channel 5190MHz Ant 0+1+2+3	

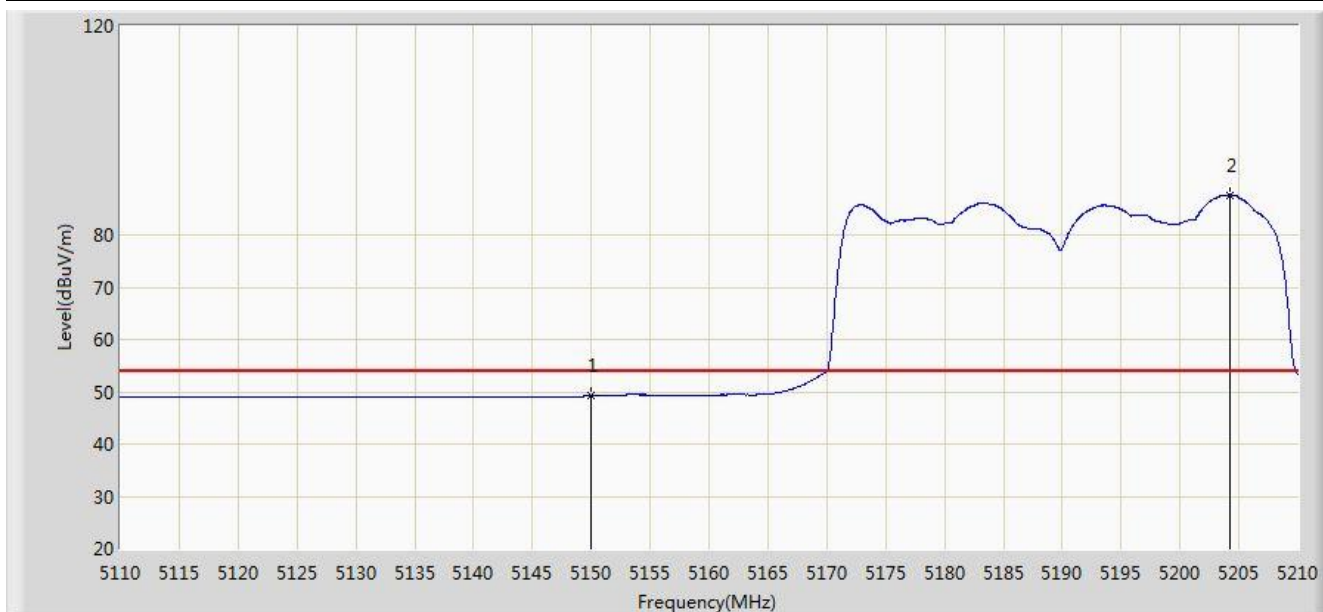

No	Flag	Mark	Frequency (MHz)	Measure Level (dBuV/m)	Reading Level (dBuV)	Over Limit (dB)	Limit (dBuV/m)	Factor (dB)	Type
1			5150.000	49.175	12.423	-4.825	54.000	36.752	AV
2		*	5204.200	87.672	51.068	N/A	N/A	36.604	AV

Note: Measure Level (dB μ V/m) = Reading Level (dB μ V) + Factor (dB)

Factor (dB) = Cable Loss (dB) + Antenna Factor (dB/m).

Engineer: Roy Cheng	
Site: AC1	Time: 2014/07/18 - 15:13
Limit: FCC_Part15.209_RE(3m)	Margin: 0
Probe: BBHA9120D_1-18GHz	Polarity: Vertical
EUT: WIFI dual band 4 GE LAN GPON HGU	Power: AC 120V/60Hz
Note: Mode 5: Transmit by 802.11ac40 at channel 5190MHz Ant 0+1+2+3	

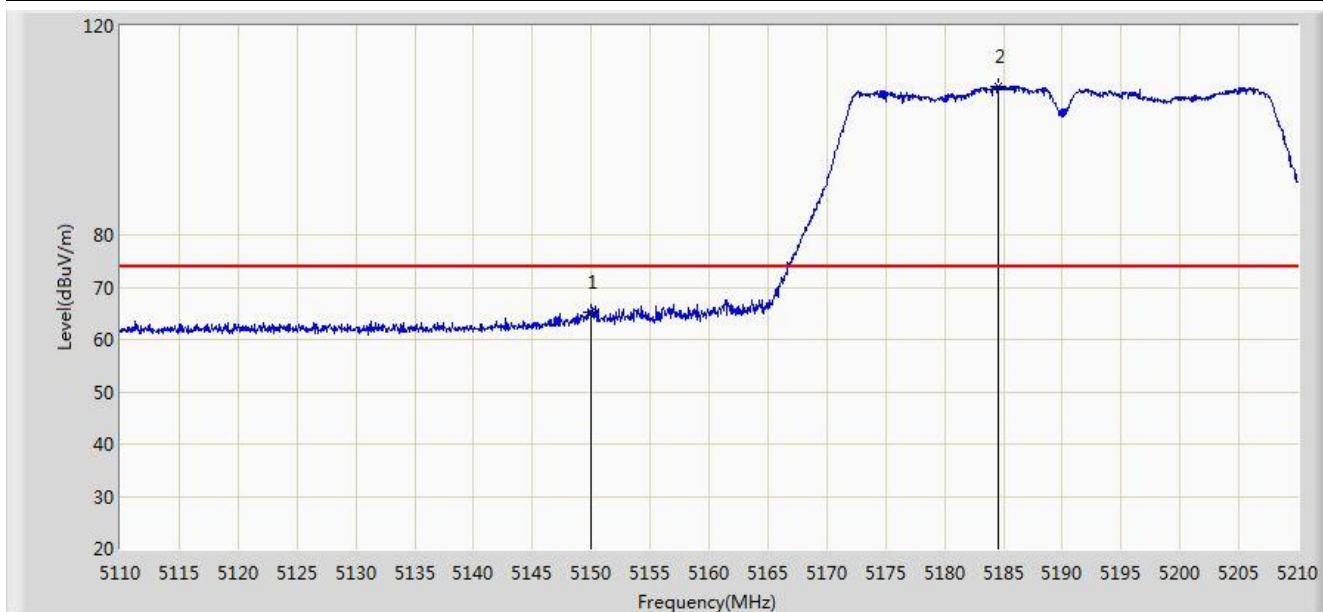

No	Flag	Mark	Frequency (MHz)	Measure Level (dBuV/m)	Reading Level (dBuV)	Over Limit (dB)	Limit (dBuV/m)	Factor (dB)	Type
1			5150.000	65.111	28.359	-8.889	74.000	36.752	PK
2		*	5184.600	108.400	71.748	N/A	N/A	36.652	PK

Note: Measure Level (dB μ V/m) = Reading Level (dB μ V) + Factor (dB)

Factor (dB) = Cable Loss (dB) + Antenna Factor (dB/m).

Engineer: Roy Cheng	
Site: AC1	Time: 2014/07/18 - 15:14
Limit: FCC_Part15.209_RE(3m)	Margin: 0
Probe: BBHA9120D_1-18GHz	Polarity: Vertical
EUT: WIFI dual band 4 GE LAN GPON HGU	Power: AC 120V/60Hz
Note: Mode 5: Transmit by 802.11ac40 at channel 5190MHz Ant 0+1+2+3	

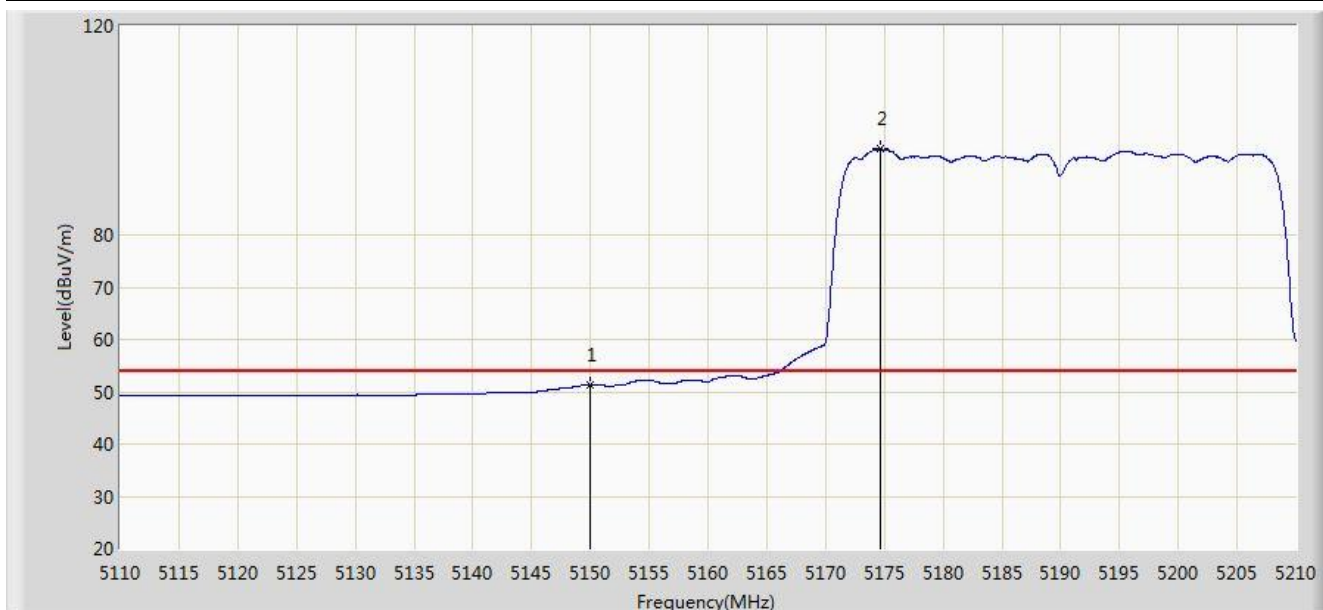

No	Flag	Mark	Frequency (MHz)	Measure Level (dBuV/m)	Reading Level (dBuV)	Over Limit (dB)	Limit (dBuV/m)	Factor (dB)	Type
1			5150.000	51.344	14.592	-2.656	54.000	36.752	AV
2		*	5174.650	96.397	59.715	N/A	N/A	36.683	AV

Note: Measure Level (dB μ V/m) = Reading Level (dB μ V) + Factor (dB)

Factor (dB) = Cable Loss (dB) + Antenna Factor (dB/m).

Engineer: Roy Cheng	
Site: AC1	Time: 2014/07/18 - 15:59
Limit: FCC_Part15.209_RE(3m)	Margin: 0
Probe: BBHA9120D_1-18GHz	Polarity: Horizontal
EUT: WIFI dual band 4 GE LAN GPON HGU	Power: AC 120V/60Hz
Note: Mode 6: Transmit by 802.11ac80 at channel 5210MHz Ant 0+1+2+3	

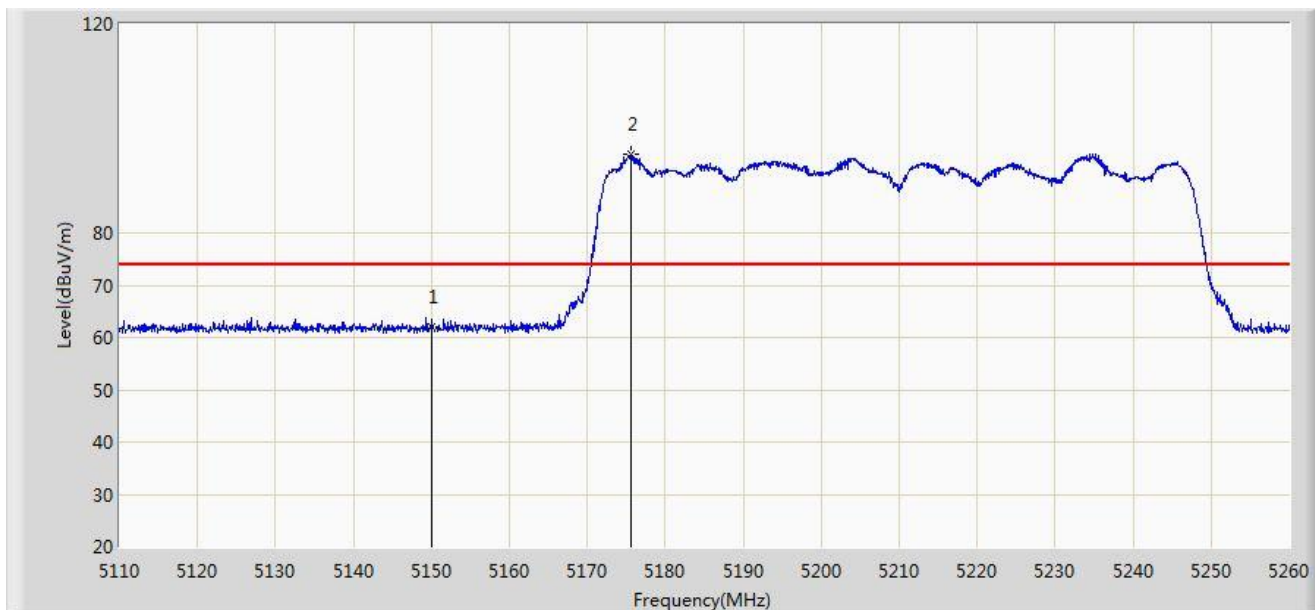

No	Flag	Mark	Frequency (MHz)	Measure Level (dBuV/m)	Reading Level (dBuV)	Over Limit (dB)	Limit (dBuV/m)	Factor (dB)	Type
1			5150.000	61.969	25.217	-12.031	74.000	36.752	PK
2		*	5175.625	94.961	58.282	N/A	N/A	36.679	PK

Note: Measure Level (dB μ V/m) = Reading Level (dB μ V) + Factor (dB)

Factor (dB) = Cable Loss (dB) + Antenna Factor (dB/m).

Engineer: Roy Cheng	
Site: AC1	Time: 2014/07/18 - 16:01
Limit: FCC_Part15.209_RE(3m)	Margin: 0
Probe: BBHA9120D_1-18GHz	Polarity: Horizontal
EUT: WIFI dual band 4 GE LAN GPON HGU	Power: AC 120V/60Hz
Note: Mode 6: Transmit by 802.11ac80 at channel 5210MHz Ant 0+1+2+3	

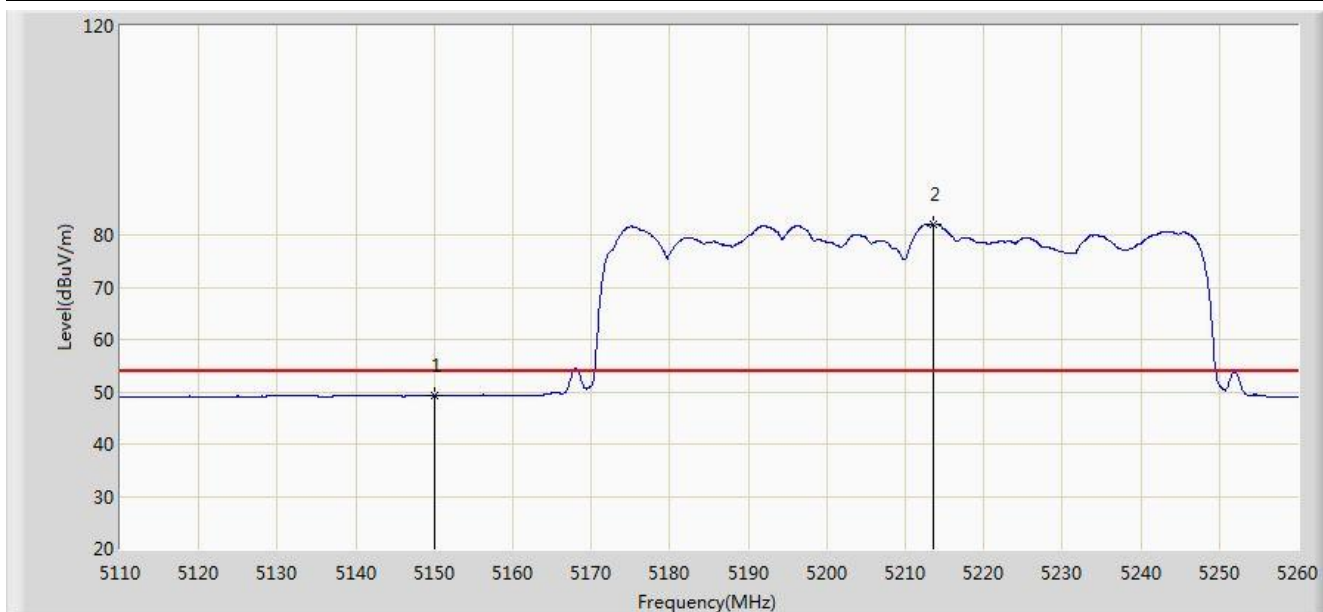

No	Flag	Mark	Frequency (MHz)	Measure Level (dBuV/m)	Reading Level (dBuV)	Over Limit (dB)	Limit (dBuV/m)	Factor (dB)	Type
1			5150.000	49.185	12.433	-4.815	54.000	36.752	AV
2		*	5213.500	82.118	45.532	N/A	N/A	36.586	AV

Note: Measure Level (dB μ V/m) = Reading Level (dB μ V) + Factor (dB)

Factor (dB) = Cable Loss (dB) + Antenna Factor (dB/m).

Engineer: Roy Cheng	
Site: AC1	Time: 2014/07/18 - 16:05
Limit: FCC_Part15.209_RE(3m)	Margin: 0
Probe: BBHA9120D_1-18GHz	Polarity: Vertical
EUT: WIFI dual band 4 GE LAN GPON HGU	Power: AC 120V/60Hz
Note: Mode 6: Transmit by 802.11ac80 at channel 5210MHz Ant 0+1+2+3	

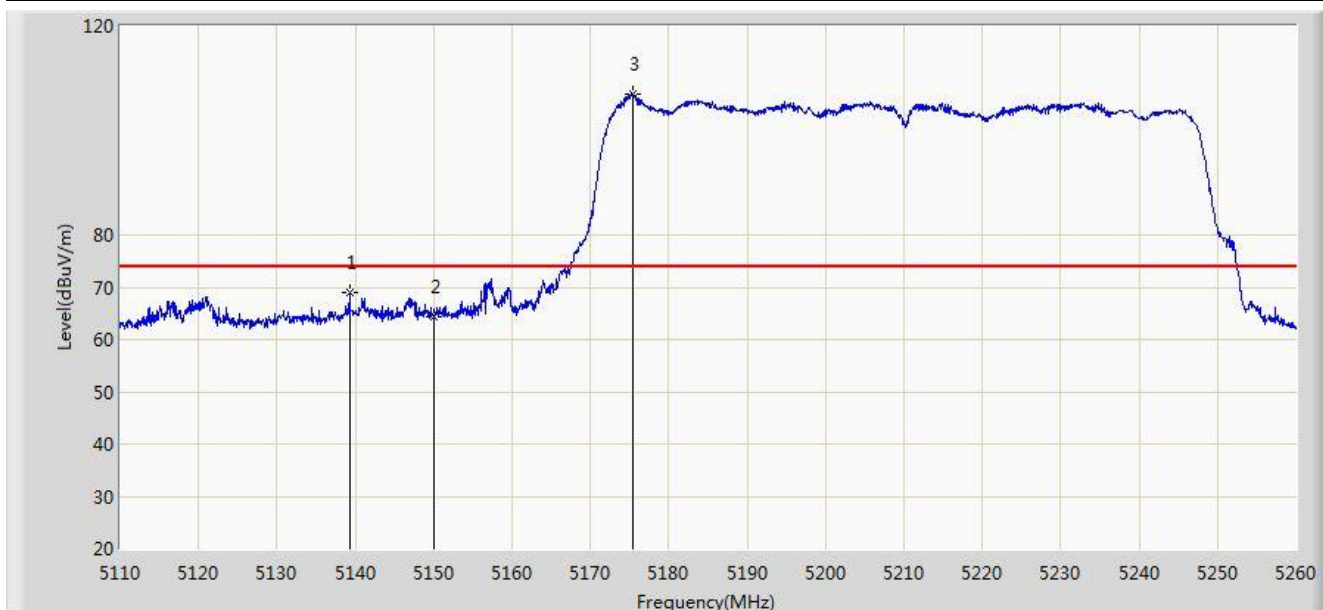

No	Flag	Mark	Frequency (MHz)	Measure Level (dBuV/m)	Reading Level (dBuV)	Over Limit (dB)	Limit (dBuV/m)	Factor (dB)	Type
1			5139.250	68.843	32.076	-5.157	74.000	36.767	PK
2			5150.000	64.352	27.600	-9.648	74.000	36.752	PK
3		*	5175.475	106.933	70.253	N/A	N/A	36.680	PK

Note: Measure Level (dBuV/m) = Reading Level (dBuV) + Factor (dB)

Factor (dB) = Cable Loss (dB) + Antenna Factor (dB/m).

Engineer: Roy Cheng	
Site: AC1	Time: 2014/07/18 - 16:06
Limit: FCC_Part15.209_RE(3m)	Margin: 0
Probe: BBHA9120D_1-18GHz	Polarity: Vertical
EUT: WIFI dual band 4 GE LAN GPON HGU	Power: AC 120V/60Hz
Note: Mode 6: Transmit by 802.11ac80 at channel 5210MHz Ant	

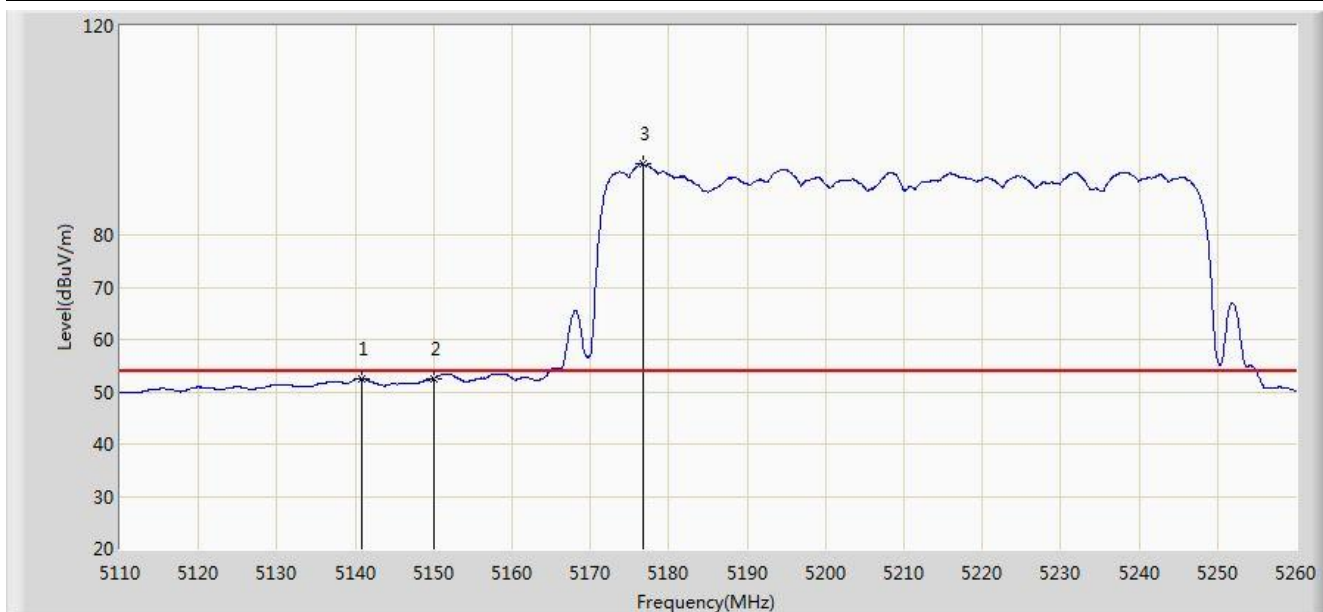

No	Flag	Mark	Frequency (MHz)	Measure Level (dBuV/m)	Reading Level (dBuV)	Over Limit (dB)	Limit (dBuV/m)	Factor (dB)	Type
1			5140.750	52.493	15.728	-1.507	54.000	36.765	AV
2			5150.000	52.483	15.731	-1.517	54.000	36.752	AV
3		*	5176.675	93.507	56.831	N/A	N/A	36.676	AV

Note: Measure Level (dB μ V/m) = Reading Level (dB μ V) + Factor (dB)

Factor (dB) = Cable Loss (dB) + Antenna Factor (dB/m).

7.10. AC Conducted Emissions Measurement §15.207; RSS-210 [7.2.4]

7.10.1. Test Limit

FCC Part 15 Subpart C Paragraph 15.207 & RSS-210 [7.2.4]		
Frequency (MHz)	QP (dB μ V)	AV (dB μ V)
0.15 - 0.50	66 - 56	56 - 46
0.50 - 5.0	56	46
5.0 - 30	60	50

Note 1: The lower limit shall apply at the transition frequencies.

Note 2: The limit decreases linearly with the logarithm of the frequency in the range 0.15MHz to 0.5MHz.

7.10.2. Test Procedure

The EUT was setup according to ANSI C63.4, 2009 and tested according to KDB 789033 for compliance to FCC 47CFR 15.247 requirements. The EUT was placed on a platform of nominal size, 1 m by 1.5 m, raised 80 cm above the conducting ground plane. The vertical conducting plane was located 40 cm to the rear of the EUT. All other surfaces of EUT were at least 80 cm from any other grounded conducting surface. The EUT and simulators are connected to the main power through a line impedance stabilization network (LISN). The LISN provides a 50 ohm /50 μ H coupling impedance for the measuring equipment. The peripheral devices are also connected to the main power through a LISN. (Please refer to the block diagram of the test setup and photographs) Each current-carrying conductor of the EUT power cord, except the ground (safety) conductor, was individually connected through a LISN to the input power source.

The excess length of the power cord between the EUT and the LISN receptacle were folded back and forth at the center of the lead to form a bundle not exceeding 40 cm in length.

Conducted emissions were investigated over the frequency range from 0.15MHz to 30MHz using a receiver bandwidth of 9 kHz.

7.10.3. Test Setup

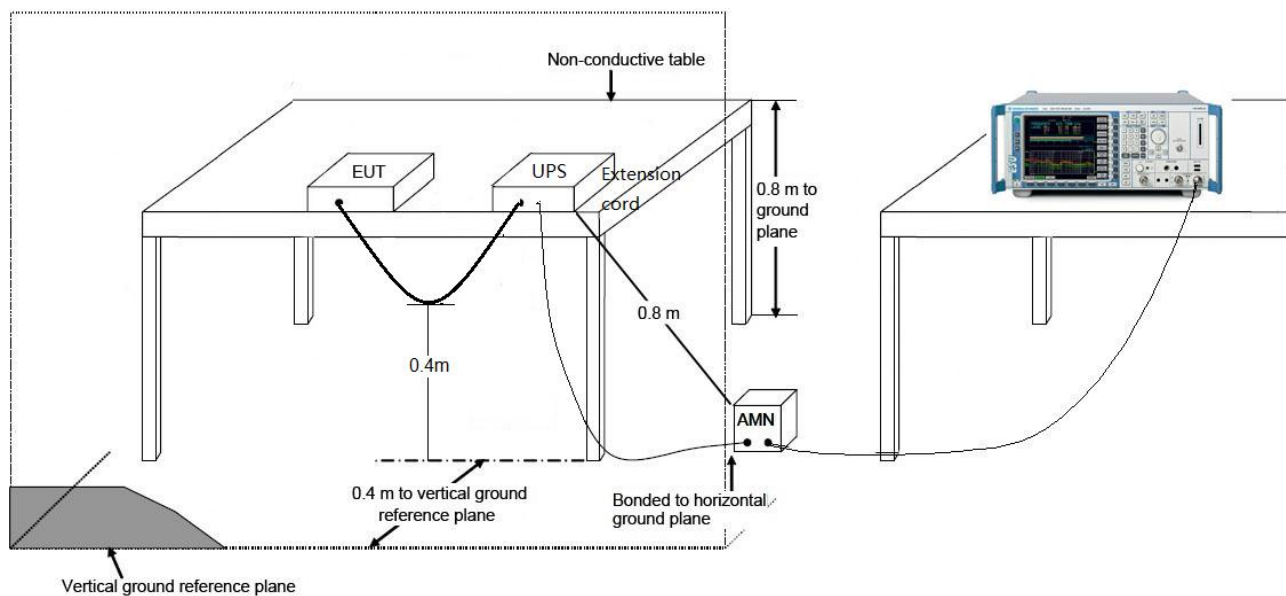

7.10.4. Test Result

Tested By	Roy Cheng	Test Date	2014/07/15 - 11:48
Site	SR2	Power	AC 120V/60Hz
Limit	FCC_Part15.207_CE_Class B	Polarity	Line
AMN	LISN_101683-FILTER ON	Test Mode	Normal Operation

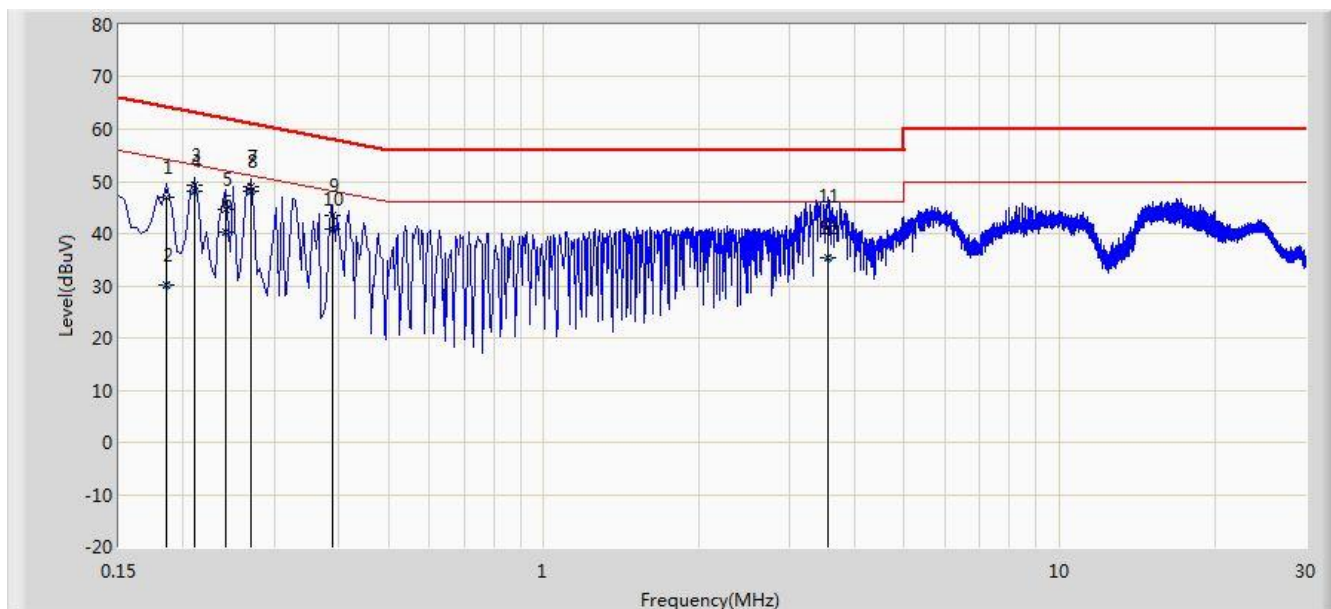

No	Flag	Mark	Frequency (MHz)	Measure Level (dBuV)	Reading Level (dBuV)	Over Limit (dB)	Limit (dBuV)	Factor (dB)	Type
1			0.186	46.970	36.935	-17.243	64.213	10.035	QP
2			0.186	30.198	20.162	-24.016	54.213	10.035	AV
3		*	0.210	49.275	39.281	-13.930	63.205	9.995	QP
4			0.210	48.161	38.167	-5.044	53.205	9.995	AV
5			0.242	44.585	34.590	-17.442	62.027	9.995	QP
6			0.242	40.350	30.355	-11.677	52.027	9.995	AV
7			0.270	49.083	39.067	-12.035	61.118	10.016	QP
8			0.270	47.979	37.963	-3.139	51.118	10.016	AV
9			0.390	43.467	33.362	-14.597	58.064	10.105	QP
10			0.390	40.835	30.730	-7.228	48.064	10.105	AV
11			3.546	41.421	31.503	-14.579	56.000	9.919	QP
12			3.546	35.301	25.382	-10.699	46.000	9.919	AV

Note: Measure Level (dBμV) = Reading Level (dBμV) + Factor (dB)

Factor (dB) = Cable Loss (dB) + LISN Factor (dB)

Tested By	Roy Cheng	Test Date	2014/07/15 - 11:54
Site	SR2	Power	AC 120V/60Hz
Limit	FCC_Part15.207_CE_Class B	Polarity	Neutral
AMN	LISN_101683-FILTER ON	Test Mode	Normal Operation

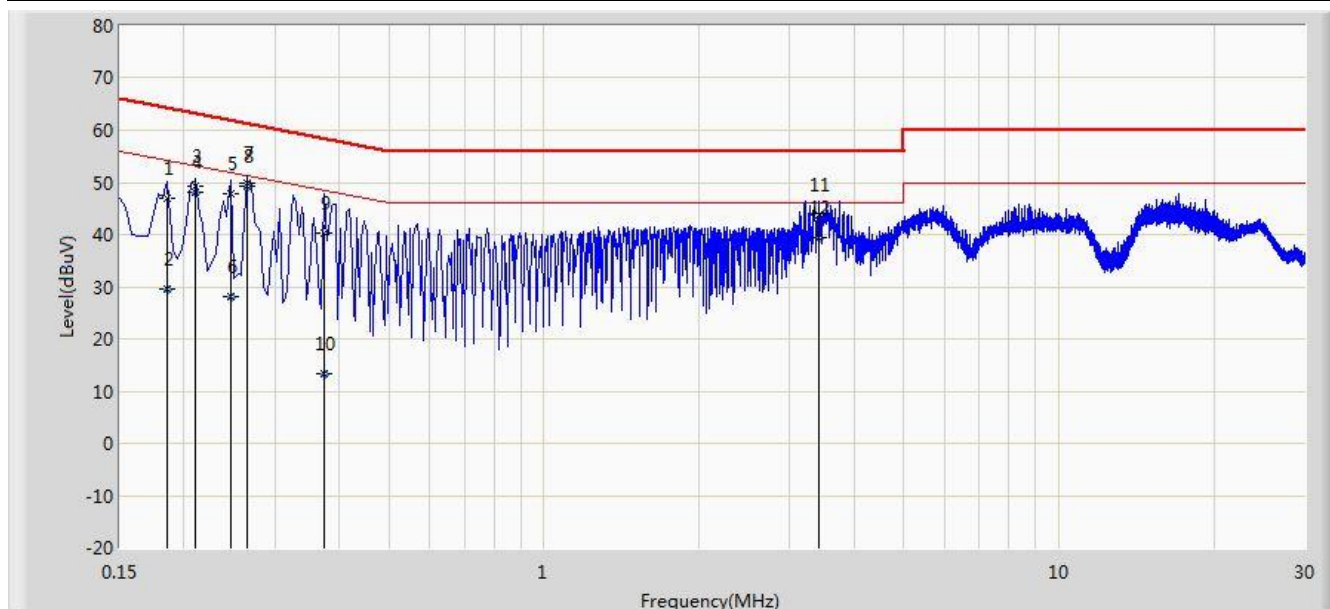

No	Flag	Mark	Frequency (MHz)	Measure Level (dBuV)	Reading Level (dBuV)	Over Limit (dB)	Limit (dBuV)	Factor (dB)	Type
1			0.186	47.051	37.016	-17.162	64.213	10.035	QP
2			0.186	29.500	19.464	-24.714	54.213	10.035	AV
3		*	0.210	49.244	39.250	-13.961	63.205	9.995	QP
4			0.210	48.122	38.128	-5.083	53.205	9.995	AV
5			0.246	47.706	37.708	-14.185	61.891	9.998	QP
6			0.246	28.218	18.220	-23.674	51.891	9.998	AV
7			0.266	49.771	39.758	-11.471	61.242	10.013	QP
8			0.266	49.155	39.142	-2.087	51.242	10.013	AV
9			0.374	40.313	30.220	-18.098	58.412	10.093	QP
10			0.374	13.310	3.217	-35.102	48.412	10.093	AV
11			3.418	43.902	33.994	-12.098	56.000	9.907	QP
12			3.418	39.552	29.644	-6.448	46.000	9.907	AV

Note: Measure Level (dBμV) = Reading Level (dBμV) + Factor (dB)

Factor (dB) = Cable Loss (dB) + LISN Factor (dB)

8. CONCLUSION

The data collected relate only the item(s) tested and show that the **WIFI dual band 4 GE LAN GPON HGU FCC ID: 2ABLK-8X4G-2** is in compliance with Part 15E of the FCC Rules.