



## DFS MEASUREMENT REPORT

### FCC PART 15.407

---

**FCC ID:** 2ABLK-8X4G-1V2

**APPLICANT:** Calix Inc.

**Application Type:** Certification

**Product:** WIFI dual band 4 GE LAN GPON HGU, BROADBAND CPE

**Model No.:** 844G-1, 854G-1, 844GE-1, C844G

**Brand Name:** Calix

**FCC Classification:** Unlicensed National Information Infrastructure (UNII)

**FCC Rule Part(s):** Part 15.407  
KDB 905462 D02v01r01, KDB 905462 D04v01

**Type of Device:**  Master Device  
 Client Device (No radar detection)  
 Client Device with radar detection

**Test Date:** March 12 ~ 23, 2015

Reviewed By : Robin Wu  
( Robin Wu )

Approved By : Marlin Chen  
( Marlin Chen )



The test results relate only to the samples tested.

This equipment has been shown to be capable of compliance with the applicable technical standards as indicated in the measurement report and was tested in accordance with the measurement procedures specified in KDB 905462 D02v01r01. Test results reported herein relate only to the item(s) tested.

The test report shall not be reproduced except in full without the written approval of MRT Technology (Suzhou) Co., Ltd.

## Revision History

Report No.	Version	Description	Issue Date
1502RSU00403	Rev. 01	Initial report	04-01-2015
1502RSU00403	Rev. 02	Added the model number "844GE-1"	11-24-2015
1502RSU00403	Rev. 03	Add the UK adapter	03-29-2016
1502RSU00403	Rev. 04	Add the product name and model number	04-24-2016

---

## CONTENTS

Description	Page
<b>Revision History</b> .....	<b>2</b>
<b>§2.1033 General Information</b> .....	<b>5</b>
<b>1. INTRODUCTION</b> .....	<b>6</b>
1.1. Scope .....	6
1.2. MRT Test Location .....	6
<b>2. PRODUCT INFORMATION</b> .....	<b>7</b>
2.1. Equipment Description.....	7
2.2. Description of Available Antennas .....	9
2.3. Description of Antenna RF Port .....	10
2.4. DFS Band Carrier Frequencies Operation .....	11
2.5. Test Mode.....	12
<b>3. DFS DETECTION THRESHOLDS AND RADAR TEST WAVEFORMS</b> .....	<b>13</b>
3.1. Applicability.....	13
3.2. DFS Devices Requirements.....	14
3.3. DFS Detection Threshold Values .....	15
3.4. Parameters of DFS Test Signals .....	16
3.5. Conducted Test Setup.....	19
<b>4. TEST EQUIPMENT CALIBRATION DATE</b> .....	<b>20</b>
<b>5. TEST RESULT</b> .....	<b>21</b>
5.1. Summary .....	21
5.2. Radar Waveform Calibration.....	22
5.2.1. Calibration Setup .....	22
5.2.2. Calibration Procedure .....	22
5.2.3. Calibration Result .....	23
5.3. Channel Loading Test Result .....	27
5.4. UNII Detection Bandwidth Measurement .....	29
5.4.1. Test Limit .....	29
5.4.2. Test Procedure .....	29
5.4.3. Test Result.....	30
5.5. Initial Channel Availability Check Time Measurement .....	36
5.5.1. Test Limit .....	36
5.5.2. Test Procedure .....	36
5.5.3. Test Result.....	37

---

5.6.	Radar Burst at the Beginning of the Channel Availability Check Time Measurement ..	38
5.6.1.	Test Limit .....	38
5.6.2.	Test Procedure .....	38
5.6.3.	Test Result.....	39
5.7.	Radar Burst at the End of the Channel Availability Check Time Measurement .....	40
5.7.1.	Test Limit .....	40
5.7.2.	Test Procedure .....	40
5.7.3.	Test Result.....	41
5.8.	In-Service Monitoring for Channel Move Time, Channel Closing Transmission Time and Non-Occupancy Period Measurement .....	42
5.8.1.	Test Limit .....	42
5.8.2.	Test Procedure Used .....	42
5.8.3.	Test Result.....	43
5.9.	Statistical Performance Check Measurement.....	45
5.9.1.	Test Limit .....	45
5.9.2.	Test Procedure .....	45
5.9.3.	Test Result.....	46
<b>6.</b>	<b>CONCLUSION.....</b>	<b>123</b>

## §2.1033 General Information

<b>Applicant:</b>	Calix Inc.
<b>Applicant Address:</b>	1035 N. McDowell Blvd Petaluma, CA94954 U.S.A
<b>Manufacturer:</b>	Calix Inc.
<b>Manufacturer Address:</b>	1035 N. McDowell Blvd Petaluma, CA94954 U.S.A
<b>Test Site:</b>	MRT Technology (Suzhou) Co., Ltd
<b>Test Site Address:</b>	D8 Building, Youxin Industrial Park, No.2 Tian'edang Rd., Wuzhong Economic Development Zone, Suzhou, China
<b>MRT FCC Registration No.:</b>	809388
<b>Model No.:</b>	844G-1, 854G-1, 844GE-1, C844G
<b>FCC ID:</b>	2ABLK-8X4G-1V2
<b>Test Device Serial No.:</b>	N/A <input type="checkbox"/> Production <input checked="" type="checkbox"/> Pre-Production <input type="checkbox"/> Engineering
<b>FCC Classification:</b>	Unlicensed National Information Infrastructure (UNII)

### Test Facility / Accreditations

Measurements were performed at MRT Laboratory located in Tian'edang Rd., Suzhou, China.

- MRT facility is a FCC registered (MRT Reg. No. 809388) test facility with the site description report on file and has met all the requirements specified in Section 2.948 of the FCC Rules.
- MRT facility is an IC registered (MRT Reg. No. 11384A-1) test laboratory with the site description on file at Industry Canada.
- MRT facility is a VCCI registered (R-4179, G-814, C-4664, T-2206) test laboratory with the site description on file at VCCI Council.
- MRT Lab is accredited to ISO 17025 by the American Association for Laboratory Accreditation (A2LA) under the American Association for Laboratory Accreditation Program (A2LA Cert. No. 3628.01) in EMC, Telecommunications and Radio testing for FCC, Industry Canada, EU and TELEC Rules.



# 1. INTRODUCTION

## 1.1. Scope

Measurement and determination of electromagnetic emissions (EMC) of radio frequency devices including intentional and/or unintentional radiators for compliance with the technical rules and regulations of the Federal Communications Commission and the Industry Canada Certification and Engineering Bureau.

## 1.2. MRT Test Location

The map below shows the location of the MRT LABORATORY, its proximity to the Taihu Lake. These measurement tests were conducted at the MRT Technology (Suzhou) Co., Ltd. Facility located at D8 Building, Youxin Industrial Park, No.2 Tian'edang Rd., Wuzhong Economic Development Zone, Suzhou, China. The detailed description of the measurement facility was found to be in compliance with the requirements of § 2.948 according to ANSI C63.4-2009 on September 30, 2013.



## 2. PRODUCT INFORMATION

### 2.1. Equipment Description

Product Name	WIFI dual band 4 GE LAN GPON HGU, BROADBAND CPE
Model No.	844G-1, 854G-1, 844GE-1, C844G
Radio Type	Intentional Transceiver
Operation Mode	Master Device
Frequency Range	<p>For 802.11a/n-HT20: 5260~5320MHz, 5500~5700MHz</p> <p>For 802.11ac-VHT20: 5260~5320MHz, 5500~5720MHz</p> <p>For 802.11n-HT40: 5270~5310MHz, 5510~5670MHz</p> <p>For 802.11ac-VHT40: 5270~5310MHz, 5510~5710MHz</p> <p>For 802.11ac-VHT80: 5290MHz, 5530MHz, 5610MHz, 5690MHz</p>
Maximum Output Power	<p>802.11a: 20.65dBm</p> <p>802.11n-HT20: 20.50dBm</p> <p>802.11ac-VHT20: 21.16dBm</p> <p>802.11n-HT40: 20.79dBm</p> <p>802.11ac-VHT40: 21.26dBm</p> <p>802.11ac-VHT80: 20.92dBm</p>
Type of Modulation	802.11a/n/ac: OFDM;
Power-on cycle	Requires 181.7 seconds to complete its power-on cycle.
Uniform Spreading	For the 5250-5350MHz, 5470-5725 MHz bands, the Master device provides, on aggregate, uniform loading of the spectrum across all devices by selecting an operating channel among the available channels using a random algorithm.

Components	
UPS #1	M/N: D13CU12V-NA3-G Input: 100-240V ~ 50/60Hz, 1.0A OUTPUT: 12Vdc, 30W
UPS #2	M/N: D13CU12V-NA3-G Input: 100-240V ~ 50/60Hz, 1.0A OUTPUT: 12Vdc, 36W
Adapter #1	M/N: AMS157-1202500FU Input: 100-240V ~ 50/60Hz, 1.0A OUTPUT: 12Vdc, 2.5A
Adapter #2	M/N: AMS157-1202500FB Input: 100-120V ~ 50/60Hz, 1.0A OUTPUT: 12Vdc, 2.5A

Note 1: There is different laser module between models “844G-1” & “844GE-1”.

Note 2: For this model “844GE-1” has been assessed the worst case mode in this report, and showed in the Annex 1 of “DTS Report & NII Report”.

Note 3: There is different DDR between models “844G-1” & “C844G”, for this model “C844G” has been assessed the worst case mode in this report, and showed in the Annex 2 of “DTS Report & NII Report”.



## 2.2. Description of Available Antennas

Antenna Type	Frequency Band (GHz)	T <sub>x</sub> Paths	Directional Gain (dBi)
PCB Antenna	2.4	2	1.90

Antenna Type	Frequency Band (GHz)	T <sub>x</sub> Paths	Directional Gain (dBi)	
			Beam Forming	CDD
PCB Antenna	5.2	4	8.04	8.04
	5.3	4	7.78	7.78
	5.6	4	8.38	8.38
	5.8	4	8.70	8.70

Note:

- Transmit at 2.4GHz support two antennas, and support four antennas at 5GHz transmit. There are different antenna gains between each antenna.
- The EUT working on Beam Forming mode, and the Beam Forming support 802.11n/ac, not include 802.11a, and 802.11a working on CDD mode.
- Correlated signals include, but are not limited to, signals transmitted in any of the following modes:
  - Any transmit Beam Forming mode, whether fixed or adaptive (e.g., phased array modes, closed loop MIMO modes, Transmitter Adaptive Antenna modes, Maximum Ratio Transmission (MRT) modes, and Statistical Eigen Beam Forming (EBF) modes).
- Unequal antenna gains, with equal transmit powers. For antenna gains given by  $G_1, G_2, \dots, G_N$  dBi
  - transmit signals are correlated, then
  - Directional gain =  $10 \log[(10^{G_1/20} + 10^{G_2/20} + \dots + 10^{G_N/20})^2 / N_{ANT}]$  dBi [Note the "20"s in the denominator of each exponent and the square of the sum of terms; the object is to combine the signal levels coherently.]

### 2.3. Description of Antenna RF Port

RF Port				
Test Mode	Software Control Port			
2.4GHz T <sub>x</sub>	Ant 0	Ant 1	--	--
Test Mode	Software Control Port			
5GHz T <sub>x</sub>	Ant 0	Ant 1	Ant 2	Ant 3

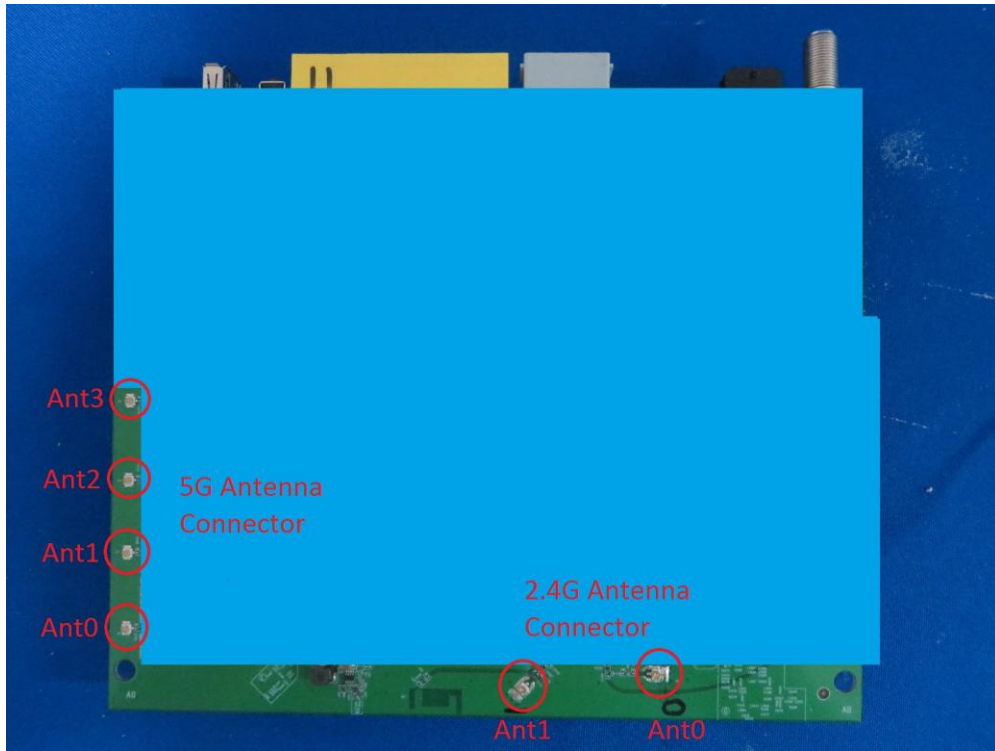

## 2.4. DFS Band Carrier Frequencies Operation

### 802.11a/n-HT20 Center Working Frequency of Each Channel

Channel	Frequency	Channel	Frequency	Channel	Frequency
52	5260 MHz	56	5280 MHz	60	5300 MHz
64	5320 MHz	100	5500 MHz	104	5520 MHz
108	5540 MHz	112	5560 MHz	116	5580 MHz
120	5600 MHz	124	5620 MHz	128	5640 MHz
132	5660 MHz	136	5680 MHz	140	5700 MHz

### 802.11ac-VHT20 Center Working Frequency of Each Channel

Channel	Frequency	Channel	Frequency	Channel	Frequency
52	5260 MHz	56	5280 MHz	60	5300 MHz
64	5320 MHz	100	5500 MHz	104	5520 MHz
108	5540 MHz	112	5560 MHz	116	5580 MHz
120	5600 MHz	124	5620 MHz	128	5640 MHz
132	5660 MHz	136	5680 MHz	140	5700 MHz
144	5720 MHz	N/A	N/A	N/A	N/A

### 802.11n-HT40 Center Working Frequency of Each Channel

Channel	Frequency	Channel	Frequency	Channel	Frequency
54	5270 MHz	62	5310 MHz	102	5510 MHz
110	5550 MHz	118	5590 MHz	126	5630 MHz
134	5670 MHz	N/A	N/A	N/A	N/A

### 802.11ac-VHT40 Center Working Frequency of Each Channel

Channel	Frequency	Channel	Frequency	Channel	Frequency
54	5270 MHz	62	5310 MHz	102	5510 MHz
110	5550 MHz	118	5590 MHz	126	5630 MHz
134	5670 MHz	142	5710MHz	N/A	N/A

## 802.11ac-VHT80 Center Working Frequency of Each Channel

Channel	Frequency	Channel	Frequency	Channel	Frequency
58	5290 MHz	106	5530 MHz	122	5610 MHz
138	5690 MHz	N/A	N/A	N/A	N/A

**2.5. Test Mode**

Test Mode	Mode 1: Communication with Notebook
-----------	-------------------------------------

### 3. DFS DETECTION THRESHOLDS AND RADAR TEST WAVEFORMS

#### 3.1. Applicability

The following table from FCC KDB 905462 D02 UNII DFS Compliance Procedures New Rules v01r01 lists the applicable requirements for the DFS testing.

Requirement	Operational Mode		
	Master	Client Without Radar Detection	Client With Radar Detection
Non-Occupancy Period	Yes	Not required	Yes
DFS Detection Threshold	Yes	Not required	Yes
Channel Availability Check Time	Yes	Not required	Not required
U-NII Detection Bandwidth	Yes	Not required	Yes

**Table 3-1: Applicability of DFS Requirements Prior to Use of a Channel**

Requirement	Operational Mode	
	Master Device or Client With Radar Detection	Client Without Radar Detection
DFS Detection Threshold	Yes	Not required
Channel Closing Transmission Time	Yes	Yes
Channel Move Time	Yes	Yes
U-NII Detection Bandwidth	Yes	Not required

Additional requirements for devices with multiple bandwidth modes	Master Device or Client with Radar Detection	Client Without Radar Detection
U-NII Detection Bandwidth and Statistical Performance Check	All BW modes must be tested	Not required
Channel Move Time and Channel Closing Transmission Time	Test using widest BW mode available	Test using the widest BW mode available for the link
All other tests	Any single BW mode	Not required

Note: Frequencies selected for statistical performance check should include several frequencies within the radar detection bandwidth and frequencies near the edge of the radar detection bandwidth. For 802.11 devices it is suggested to select frequencies in each of the bonded 20 MHz channels and the channel center frequency.

**Table 3-2: Applicability of DFS Requirements during normal operation**

### 3.2. DFS Devices Requirements

**Per FCC KDB 905462 D02 UNII DFS Compliance Procedures New Rules v01r01 the following are the requirements for Master Devices:**

- (a) The Master Device will use DFS in order to detect Radar Waveforms with received signal strength above the DFS Detection Threshold in the 5250 ~ 5350 MHz and 5470 ~ 5725 MHz bands. DFS is not required in the 5150 ~ 5250 MHz or 5725 ~ 5825 MHz bands.
- (b) Before initiating a network on a Channel, the Master Device will perform a Channel Availability Check for a specified time duration (Channel Availability Check Time) to ensure that there is no radar system operating on the Channel, using DFS described under subsection a) above.
- (c) The Master Device initiates a U-NII network by transmitting control signals that will enable other U-NII devices to Associate with the Master Device.
- (d) During normal operation, the Master Device will monitor the Channel (In-Service Monitoring) to ensure that there is no radar system operating on the Channel, using DFS described under a).
- (e) If the Master Device has detected a Radar Waveform during In-Service Monitoring as described under d), the Operating Channel of the U-NII network is no longer an Available Channel. The Master Device will instruct all associated Client Device(s) to stop transmitting on this Channel within the Channel Move Time. The transmissions during the Channel Move Time will be limited to the Channel Closing Transmission Time.
- (f) Once the Master Device has detected a Radar Waveform it will not utilize the Channel for the duration of the Non-Occupancy Period.
- (g) If the Master Device delegates the In-Service Monitoring to a Client Device, then the combination will be tested to the requirements described under d) through f) above.

**Channel Move Time and Channel Closing Transmission Time requirements are listed in the following table.**

Parameter	Value
Non-occupancy period	Minimum 30 minutes
Channel Availability Check Time	60 seconds
Channel Move Time	10 seconds See Note 1.
Channel Closing Transmission Time	200 milliseconds + an aggregate of 60 milliseconds over remaining 10 second period. See Notes 1 and 2.
U-NII Detection Bandwidth	Minimum 100% of the U-NII 99% transmission power bandwidth. See Note 3.
Note 1: Channel Move Time and the Channel Closing Transmission Time should be performed with Radar Type 0. The measurement timing begins at the end of the Radar Type 0 burst.	

Note 2: The Channel Closing Transmission Time is comprised of 200 milliseconds starting at the beginning of the Channel Move Time plus any additional intermittent control signals required to facilitate a Channel move (an aggregate of 60 milliseconds) during the remainder of the 10 second period. The aggregate duration of control signals will not count quiet periods in between transmissions.

Note 3: During the U-NII Detection Bandwidth detection test, radar type 0 should be used. For each frequency step the minimum percentage of detection is 90 percent. Measurements are performed with no data traffic.

**Table 3-3: DFS Response Requirements**

### 3.3. DFS Detection Threshold Values

The DFS detection thresholds are defined for Master devices and Client Devices with In-service monitoring. These detection thresholds are listed in the following table.

Maximum Transmit Power	Value (See Notes 1, 2, and 3)
EIRP $\geq$ 200 milliwatt	-64 dBm
EIRP $<$ 200 milliwatt and power spectral density $<$ 10 dBm/MHz	-62 dBm
EIRP $<$ 200 milliwatt that do not meet the power spectral density requirement	-64 dBm
<p><b>Note 1:</b> This is the level at the input of the receiver assuming a 0 dBi receive antenna.</p> <p><b>Note 2:</b> Throughout these test procedures an additional 1 dB has been added to the amplitude of the test transmission waveforms to account for variations in measurement equipment. This will ensure that the test signal is at or above the detection threshold level to trigger a DFS response.</p> <p><b>Note3:</b> EIRP is based on the highest antenna gain. For MIMO devices refer to KDB Publication 662911 D01.</p>	

**Table 3-4: Detection Thresholds for Master Devices and Client Devices with Radar Detection**

### 3.4. Parameters of DFS Test Signals

This section provides the parameters for required test waveforms, minimum percentage of successful detections, and the minimum number of trials that must be used for determining DFS conformance. Step intervals of 0.1 microsecond for Pulse Width, 1 microsecond for PRI, 1 MHz for chirp width and 1 for the number of pulses will be utilized for the random determination of specific test waveforms.

#### Short Pulse Radar Test Waveforms

Radar Type	Pulse Width (μsec)	PRI (μsec)	Number of Pulses	Minimum Percentage of Successful Detection	Minimum Number of Trials
0	1	1428	18	See Note 1	See Note 1
1	1	Test A: 15 unique PRI values randomly selected from the list of 23 PRI values in Table 3-6	$\text{Roundup} \left\{ \begin{array}{l} \left( \frac{1}{360} \right) \cdot \\ \left( \frac{19 \cdot 10^6}{\text{PRI}_{\mu\text{sec}}} \right) \end{array} \right\}$	60%	30
		Test B: 15 unique PRI values randomly selected within the range of 518-3066 μsec, with a minimum increment of 1 μsec, excluding PRI values selected in Test A			
2	1-5	150-230	23-29	60%	30
3	6-10	200-500	16-18	60%	30
4	11-20	200-500	12-16	60%	30
Aggregate (Radar Types 1-4)				80%	120
<b>Note 1:</b> Short Pulse Radar Type 0 should be used for the detection bandwidth test, channel move time, and channel closing time tests.					

**Table 3-5: Parameters for Short Pulse Radar Waveforms**



A minimum of 30 unique waveforms are required for each of the Short Pulse Radar Types 2 through 4. If more than 30 waveforms are used for Short Pulse Radar Types 2 through 4, then each additional waveform must also be unique and not repeated from the previous waveforms.

Pulse Repetition Frequency Number	Pulse Repetition Frequency (Pulses Per Second)	Pulse Repetition Interval (Microseconds)
1	1930.5	518
2	1858.7	538
3	1792.1	558
4	1730.1	578
5	1672.2	598
6	1618.1	618
7	1567.4	638
8	1519.8	658
9	1474.9	678
10	1432.7	698
11	1392.8	718
12	1355	738
13	1319.3	758
14	1285.3	778
15	1253.1	798
16	1222.5	818
17	1193.3	838
18	1165.6	858
19	1139	878
20	1113.6	898
21	1089.3	918
22	1066.1	938
23	326.2	3066

**Table 3-6: Pulse Repetition Intervals Values for Test A**

### Long Pulse Radar Test Waveform

Radar Type	Pulse Width (μsec)	Chirp Width (MHz)	PRI (μsec)	Number of Pulses per Burst	Number of Bursts	Minimum Percentage of Successful Detection	Minimum Number of Trials
5	50 - 100	5 - 20	1000 - 2000	1 - 3	8 - 20	80%	30

**Table 3-7: Parameters for Long Pulse Radar Waveforms**

The parameters for this waveform are randomly chosen. Thirty unique waveforms are required for the Long Pulse Radar Type waveforms. If more than 30 waveforms are used for the Long Pulse Radar Type waveforms, then each additional waveform must also be unique and not repeated from the previous waveforms.

### Frequency Hopping Radar Test Waveform

Radar Type	Pulse Width (μsec)	PRI (μsec)	Pulses Per Hop	Hopping Rate (kHz)	Hopping Sequence Length (msec)	Minimum Percentage of Successful Detection	Minimum Number of Trials
6	1	333	9	0.333	300	70%	30

**Table 3-8: Parameters for Frequency Hopping Radar Waveforms**

For the Frequency Hopping Radar Type, the same Burst parameters are used for each waveform. The hopping sequence is different for each waveform and a 100-length segment is selected from the hopping sequence defined by the following algorithm:

The first frequency in a hopping sequence is selected randomly from the group of 475 integer frequencies from 5250 – 5724MHz. Next, the frequency that was just chosen is removed from the group and a frequency is randomly selected from the remaining 474 frequencies in the group. This process continues until all 475 frequencies are chosen for the set. For selection of a random frequency, the frequencies remaining within the group are always treated as equally likely.

### 3.5. Conducted Test Setup

The FCC KDB 905462 D02 UNII DFS Compliance Procedures New Rules v01r01 describes a radiated test setup and a conducted test setup. The conducted test setup was used for this testing. Figure 3-1 shows the typical test setup.

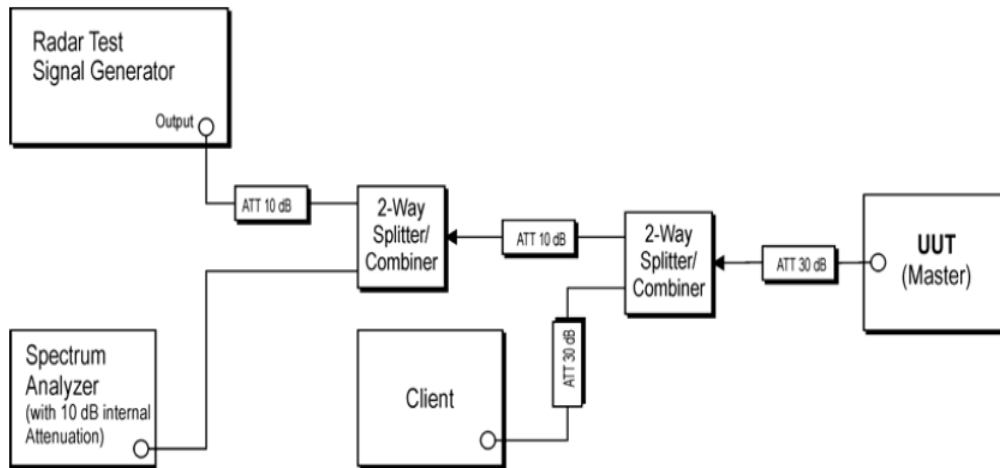

**Figure 3-1: Conducted Test Setup where UUT is a Master and Radar Test Waveforms are injected into the Masters**

#### 4. TEST EQUIPMENT CALIBRATION DATE

Dynamic Frequency Selection (DFS)

Instrument	Manufacturer	Type No.	Asset No.	Cali. Interval	Cali. Due Date
Spectrum Analyzer	Agilent	N9020A	MRTSUE06106	1 year	2016/05/08
ESG Vector Signal Generator	Agilent	E4438C	MRTSUE06026	1 year	2015/12/09
Temperature/Humidity Meter	Ouleinuo	N/A	MRTSUE06112	1 year	2015/11/20

Software	Version	Manufacturer	Function
Pulse Building	N/A	Agilent	Radar Signal Generation Software
DFS Tool	V 6.9.2	Agilent	DFS Test Software

## 5. TEST RESULT

### 5.1. Summary

**Company Name:** Calix Inc.  
**FCC ID:** 2ABLK-8X4G-1V2  
**FCC Classification:** Unlicensed National Information Infrastructure (UNII)

Parameter	Limit	Test Result	Reference
UNII Detection Bandwidth Measurement	Refer Table 3-3	Pass	Section 5.4
Initial Channel Availability Check Time	Refer Table 3-3	Pass	Section 5.5
Radar Burst at the Beginning of the Channel Availability Check Time	Refer Table 3-3	Pass	Section 5.6
Radar Burst at the End of the Channel Availability Check Time	Refer Table 3-3	Pass	Section 5.7
In-Service Monitoring for Channel Move Time, Channel Closing Transmission Time	Refer Table 3-3	Pass	Section 5.8
Non-Occupancy Period	Refer Table 3-3	Pass	Section 5.8
Statistical Performance Check	Refer Table 3-3	Pass	Section 5.9

## 5.2. Radar Waveform Calibration

### 5.2.1. Calibration Setup

The conducted test setup was used for this calibration testing. Figure 3-2 shows the typical test setup.

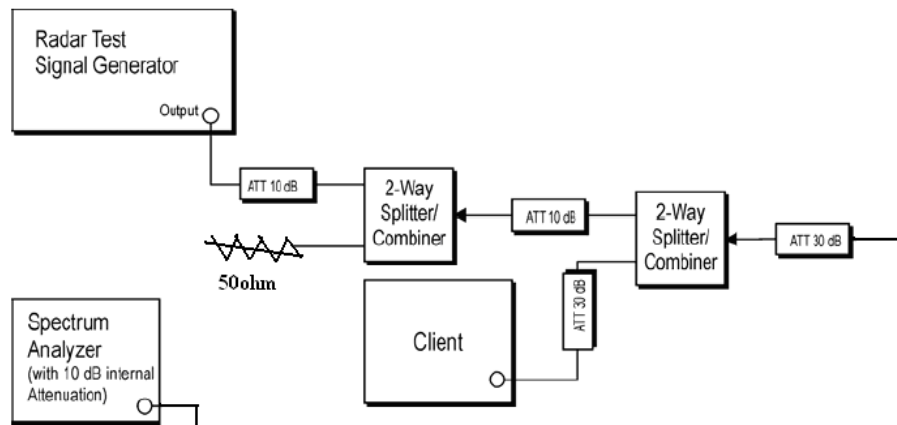

**Figure 3-2: Conducted Test Setup**

### 5.2.2. Calibration Procedure

The Interference Radar Detection Threshold Level is  $(-64\text{dBm}) + (0) [\text{dBi}] + 1 \text{ dB} = -63 \text{ dBm}$  that had been taken into account the output power range and antenna gain. The above equipment setup was used to calibrate the conducted Radar Waveform. A vector signal generator was utilized to establish the test signal level for each radar type. During this process there were replace 50ohm terminal form Master and Client device and no transmissions by either the Master or Client Device. The spectrum analyzer was switched to the zero span (Time Domain) at the frequency of the Radar Waveform generator. Peak detection was used. The spectrum analyzer resolution bandwidth (RBW) and video bandwidth (VBW) were set to at least 3MHz. The vector signal generator amplitude was set so that the power level measured at the spectrum analyzer was  $(-64\text{dBm}) + (0) [\text{dBi}] + 1 \text{ dB} = -63\text{dBm}$ . Capture the spectrum analyzer plots on short pulse radar types, long pulse radar type and hopping radar waveform.

### 5.2.3. Cablibration Result

Radar #0 DFS detection threshold level and the burst of pulses on the Channel frequency

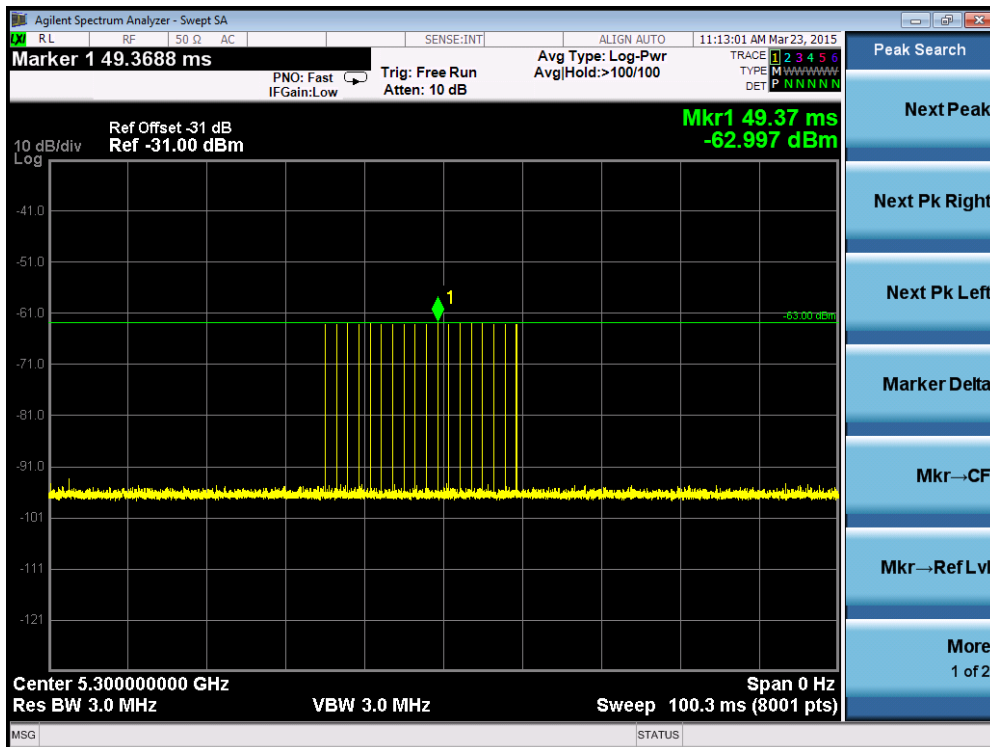

Radar #1 (Test A) DFS detection threshold level and the burst of pulses on the Channel frequency

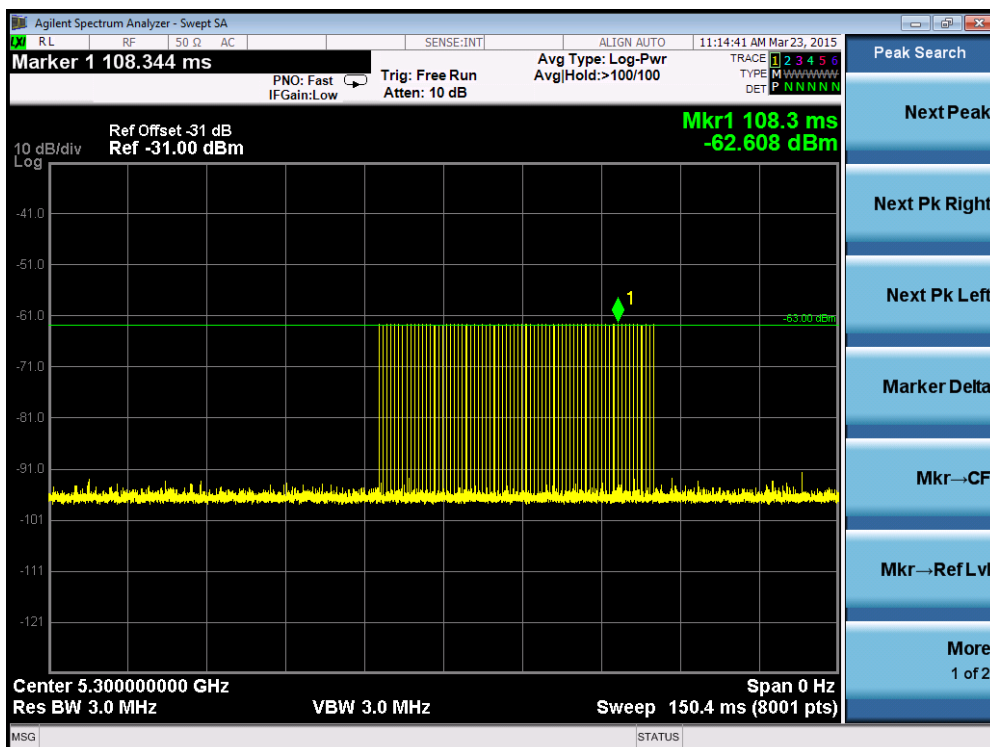

PRI = 758us and the number of pulses = 70

## Radar #1(Test B) DFS detection threshold level and the burst of pulses on the Channel frequency

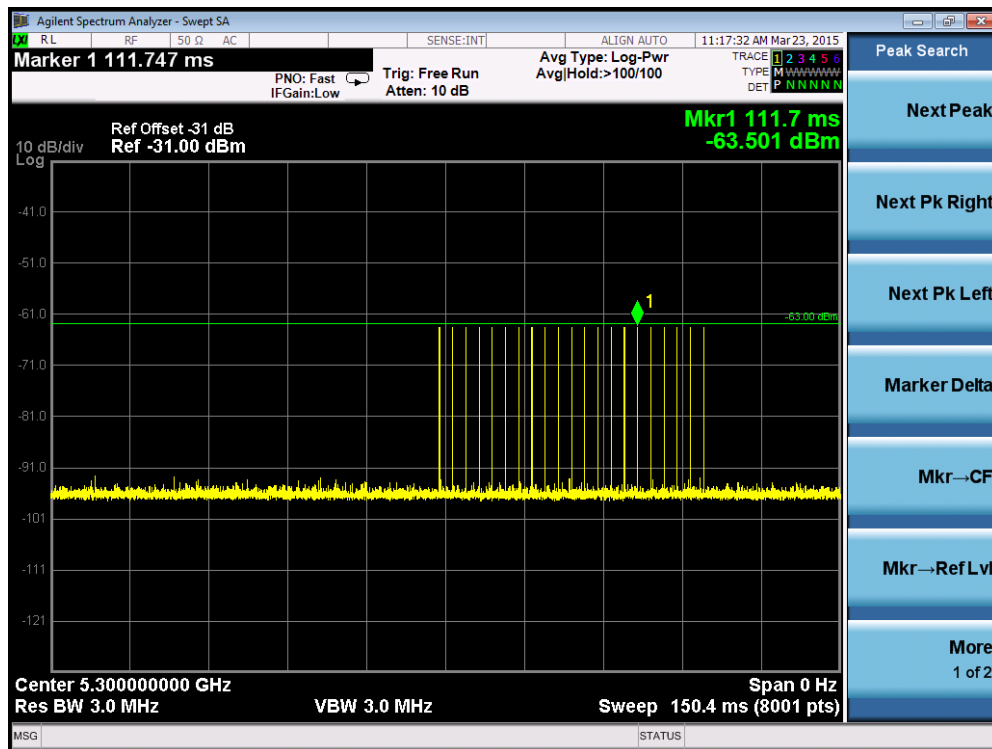

PRI = 2.575ms and the number of pulses = 21

## Radar #2 DFS detection threshold level and the burst of pulses on the Channel frequency

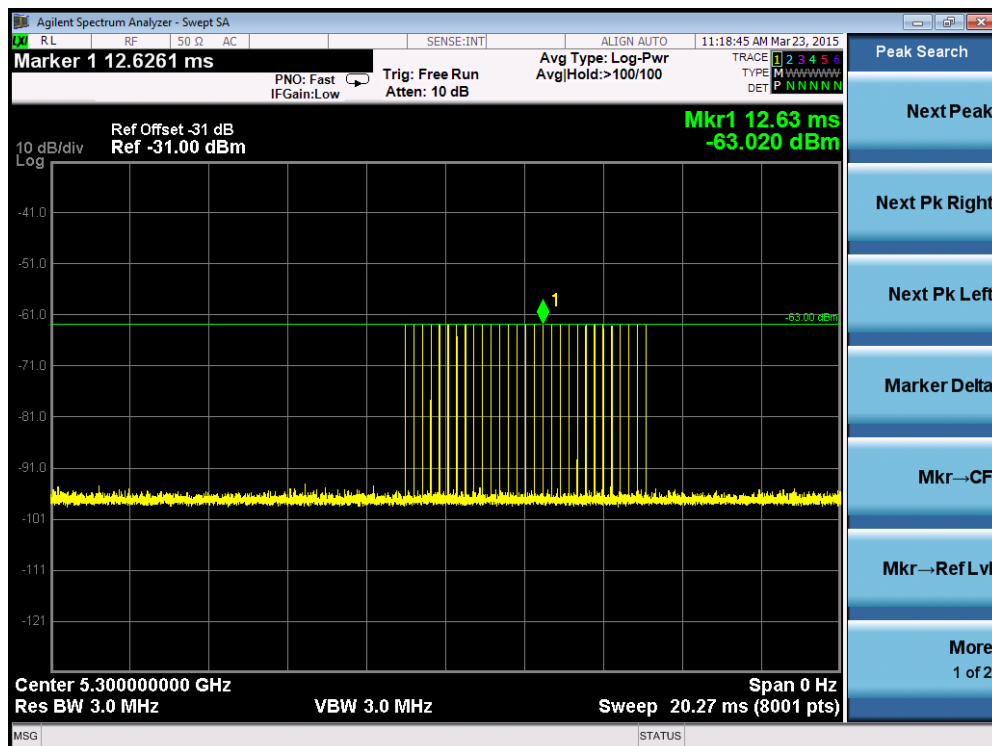



## Radar #3 DFS detection threshold level and the burst of pulses on the Channel frequency

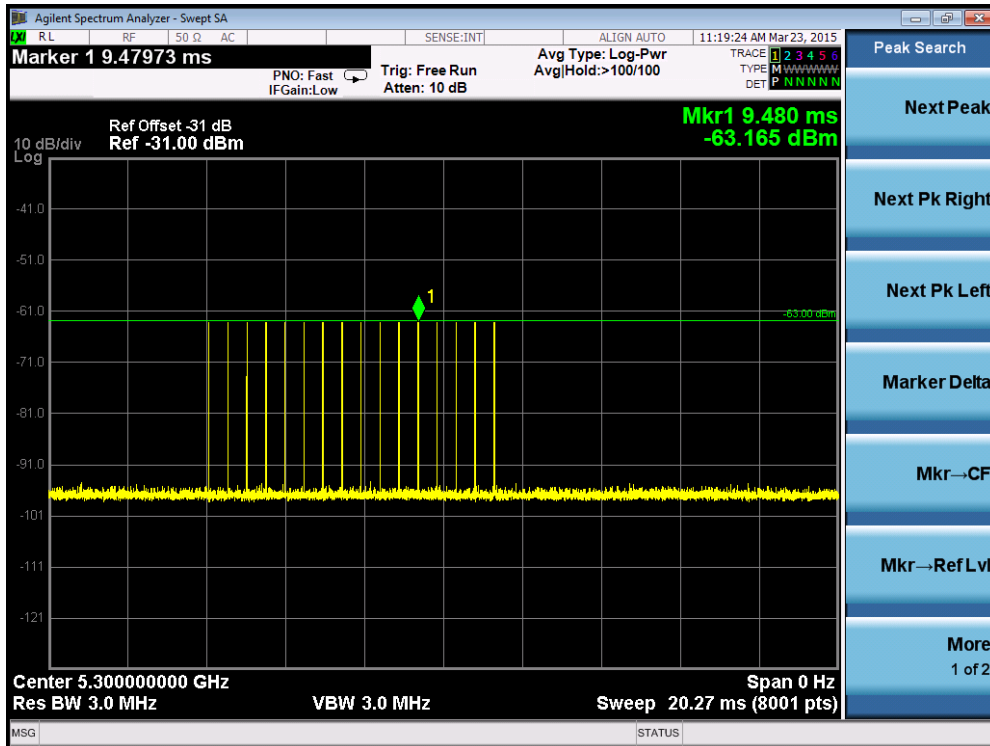

## Radar #4 DFS detection threshold level and the burst of pulses on the Channel frequency

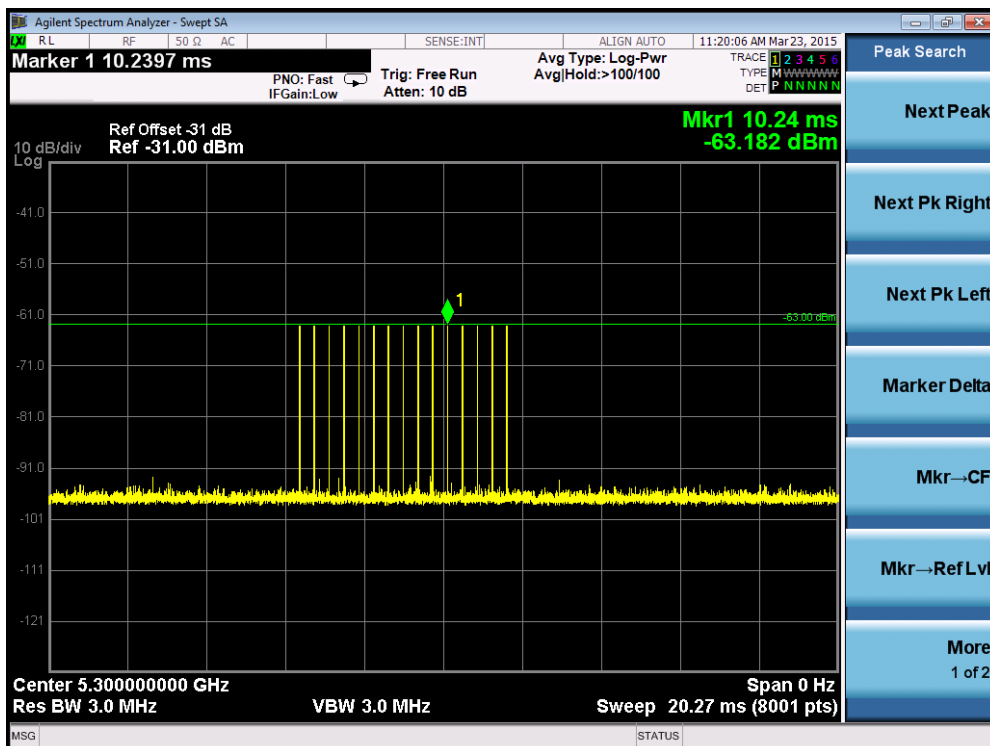

Radar #5 DFS detection threshold level and 12sec long burst on the Channel frequency

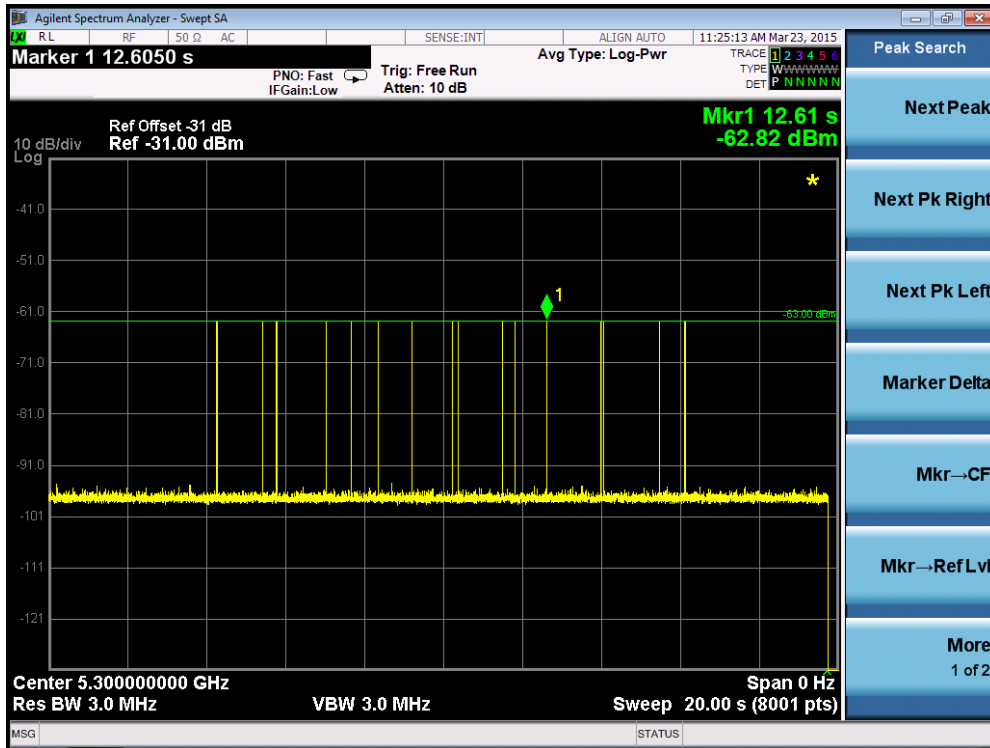

Radar #6 DFS detection threshold level and a single hop (9 pulses) on the Channel frequency within UNII detection bandwidth

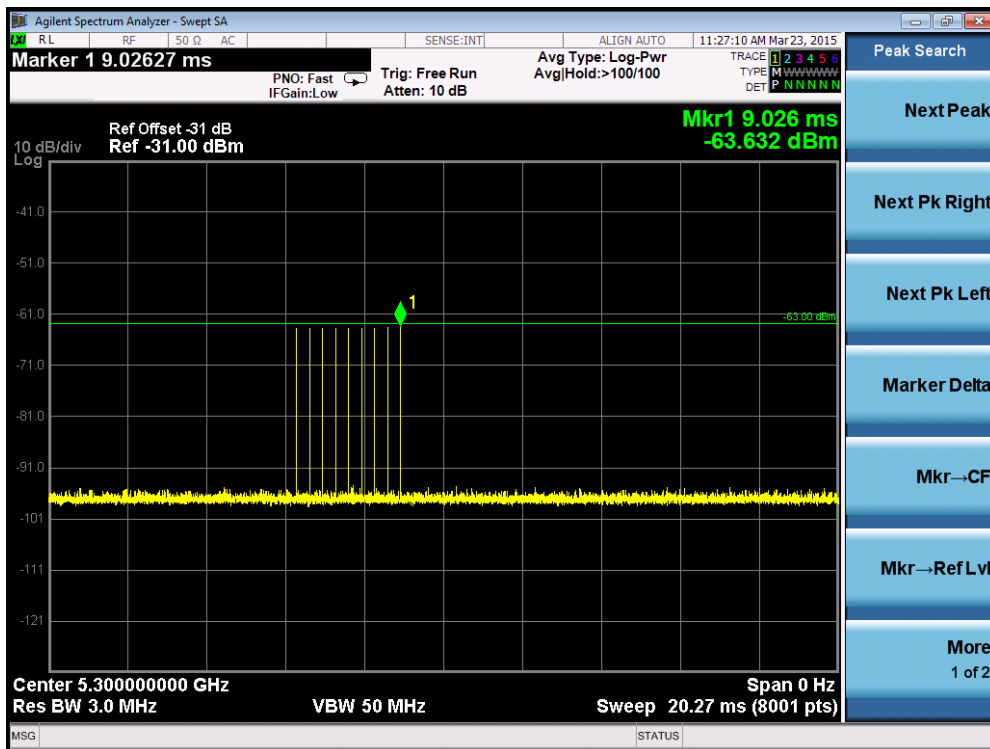

### 5.3. Channel Loading Test Result

System testing was performed with the designated MPEG test file that streams full motion video from the Indoor GPON HGU to the Client in full motion video mode using the media player with the V2.61 Codec package. This file is used by IP and Frame based systems for loading the test channel during the In-service compliance testing of the U-NII device. Packet ratio = Time On/ (Time On + Off Time).

Channel Loading Plot - 802.11a-5300MHz

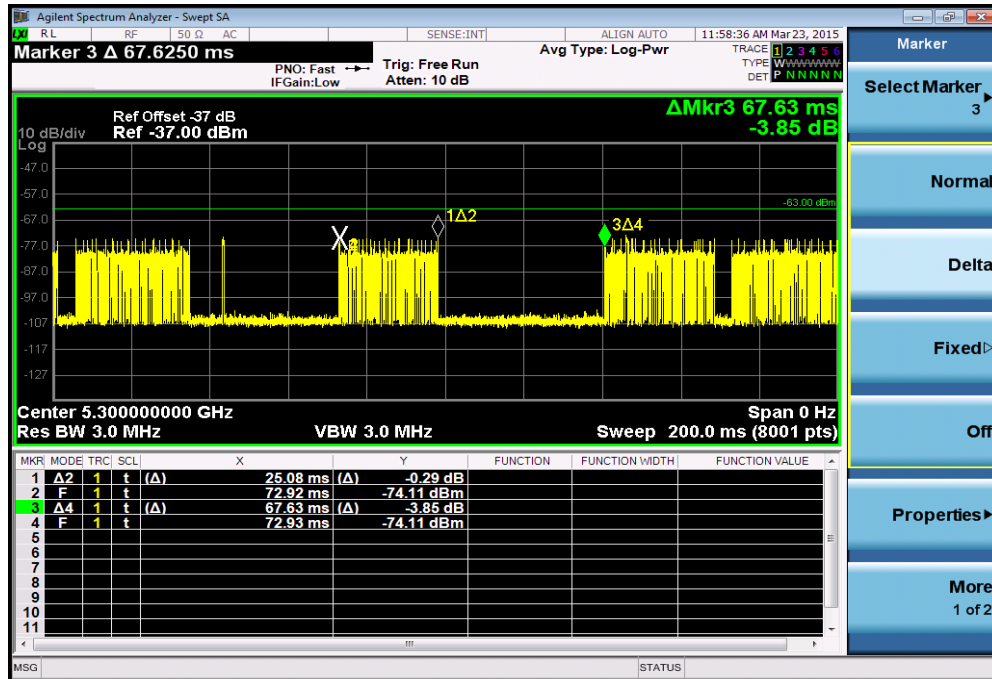

## Channel Loading Plot - 802.11n-HT40-5310MHz

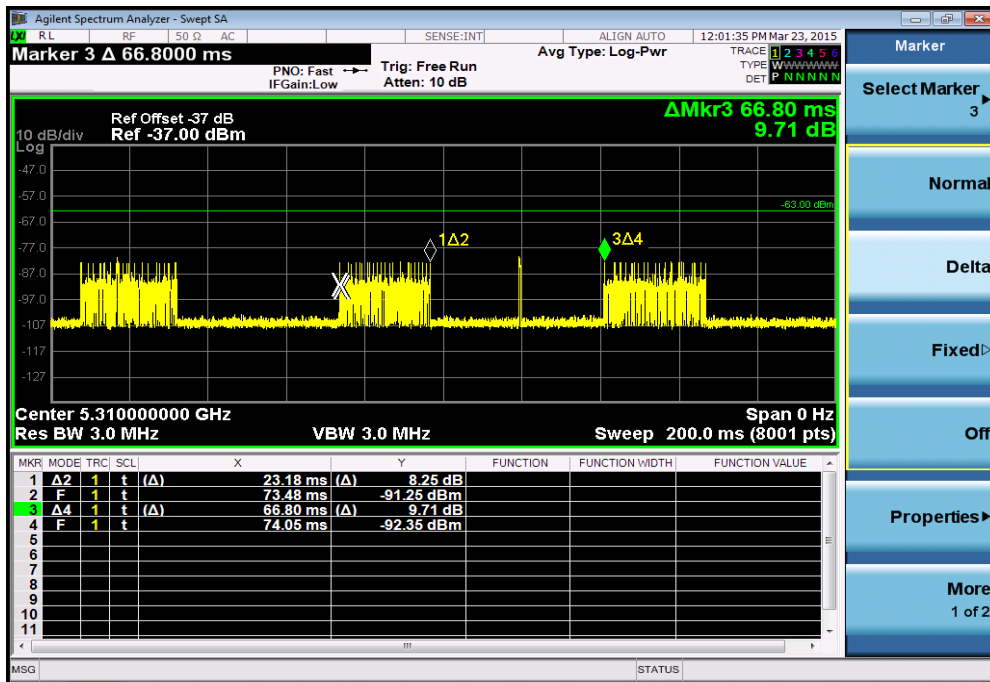

## Channel Loading Plot - 802.11ac-VHT80-5290MHz

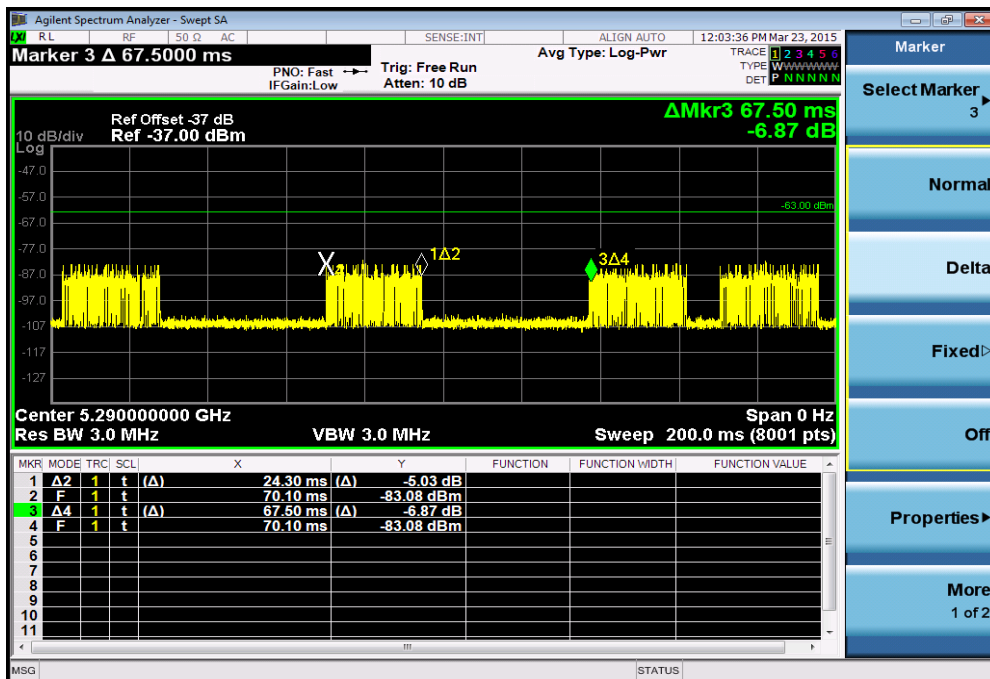

Test Mode	Packet ratio	Requirement ratio	Test Result
802.11a	37.08%	>17%	Pass
802.11n-HT40	34.70%	>17%	Pass
802.11ac-VHT80	36.00%	>17%	Pass

## 5.4. UNII Detection Bandwidth Measurement

### 5.4.1. Test Limit

Minimum 100% of the UNII 99% transmission power bandwidth. During the U-NII Detection Bandwidth detection test, each frequency step the minimum percentage of detection is 90 percent. Measurements are performed with no data traffic.

### 5.4.2. Test Procedure

1. Adjust the equipment to produce a single Burst of any one of the Short Pulse Radar Types 0-4 in Table 3-5 at the center frequency of the EUT Operating Channel at the specified DFS Detection Threshold level.
2. The generating equipment is configured as shown in the Conducted Test Setup above section 3.5.
3. The EUT is set up as a stand-alone device (no associated Client or Master, as appropriate) and no traffic. Frame based systems will be set to a talk/listen ratio reflecting the worst case (maximum) that is user configurable during this test.
4. Generate a single radar Burst, and note the response of the EUT. Repeat for a minimum of 10 trials. The EUT must detect the Radar Waveform using the specified U-NII Detection Bandwidth criterion shown in Table 3-5. In cases where the channel bandwidth may exceed past the DFS band edge on specific channels (i.e., 802.11ac or wideband frame based systems) select a channel that has the entire emission bandwidth within the DFS band. If this is not possible, test the detection BW to the DFS band edge.
5. Starting at the center frequency of the UUT operating Channel, increase the radar frequency in 5 MHz steps, repeating the above test sequence, until the detection rate falls below the U-NII Detection Bandwidth criterion specified in Table 3-3. Repeat this measurement in 1MHz steps at frequencies 5 MHz below where the detection rate begins to fall. Record the highest frequency (denote as FH) at which detection is greater than or equal to the U-NII Detection Bandwidth criterion. Recording the detection rate at frequencies above FH is not required to demonstrate compliance.
6. Starting at the center frequency of the EUT operating Channel, decrease the radar frequency in 1 MHz steps, repeating the above item 4 test sequence, until the detection rate falls below the U-NII Detection Bandwidth criterion. Record the lowest frequency (denote as FL) at which detection is greater than or equal to the U-NII Detection Bandwidth criterion. Recording the detection rate at frequencies below FL is not required to demonstrate compliance.
7. The U-NII Detection Bandwidth is calculated as follows: U-NII Detection Bandwidth = FH – FL
8. The U-NII Detection Bandwidth must be at least 100% of the EUT transmitter 99% power, otherwise, the EUT does not comply with DFS requirements.

**5.4.3. Test Result**

EUT Frequency=5300MHz for 802.11a											
Radar Frequency (MHz)	DFS Detection Trials (1=Detection, 0= No Detection)										Detection Rate (%)
	1	2	3	4	5	6	7	8	9	10	
5290	0	0	0	0	0	0	0	0	0	0	0%
5291 FL	1	1	1	1	1	1	1	1	1	1	100%
5292	1	1	1	1	1	1	1	1	1	1	100%
5293	1	1	1	1	1	1	1	1	1	1	100%
5294	1	1	1	1	1	1	1	1	1	1	100%
5295	1	1	1	1	1	1	1	1	1	1	100%
5296	1	1	1	1	1	1	1	1	1	1	100%
5297	1	1	1	1	1	1	1	1	1	1	100%
5298	1	1	1	1	1	1	1	1	1	1	100%
5299	1	1	1	1	1	1	1	1	1	1	100%
5300	1	1	1	1	1	1	1	1	1	1	100%
5301	1	1	1	1	1	1	1	1	1	1	100%
5302	1	1	1	1	1	1	1	1	1	1	100%
5303	1	1	1	1	1	1	1	1	1	1	100%
5304	1	1	1	1	1	1	1	1	1	1	100%
5305	1	1	1	1	1	1	1	1	1	1	100%
5306	1	1	1	1	1	1	1	1	1	1	100%
5307	1	1	1	1	1	1	1	1	1	1	100%
5308	1	1	1	1	1	1	1	1	1	1	100%
5309 FH	1	1	1	1	1	1	1	1	1	1	100%
5310	0	0	0	0	0	0	0	0	0	0	0%
Detection Bandwidth = FH - FL = 5309MHz - 5291MHz = 18MHz											
EUT 99% Bandwidth = 16.69MHz (see note)											
UNII Detection Bandwidth Min. Limit (MHz): 16.69MHz x 100% = 16.69MHz											

Note: All UNII channels for this device have identical Channel bandwidths. Therefore, all DFS testing was done at 5300MHz. The 99% channel bandwidth is 16.75MHz. (See the 99% BW section of the RF report for further measurement details).



EUT Frequency=5310MHz for 802.11n-HT40											
Radar Frequency (MHz)	DFS Detection Trials (1=Detection, 0= No Detection)										Detection Rate (%)
	1	2	3	4	5	6	7	8	9	10	
5291	0	0	0	0	0	0	0	0	0	0	0%
5292 FL	1	1	1	1	1	1	1	1	1	1	100%
5293	1	1	1	1	1	1	1	1	1	1	100%
5294	1	1	1	1	1	1	1	1	1	1	100%
5295	1	1	1	1	1	1	1	1	1	1	100%
5296	1	1	1	1	1	1	1	1	1	1	100%
5297	1	1	1	1	1	1	1	1	1	1	100%
5298	1	1	1	1	1	1	1	1	1	1	100%
5299	1	1	1	1	1	1	1	1	1	1	100%
5300	1	1	1	1	1	1	1	1	1	1	100%
5301	1	1	1	1	1	1	1	1	1	1	100%
5302	1	1	1	1	1	1	1	1	1	1	100%
5303	1	1	1	1	1	1	1	1	1	1	100%
5304	1	1	1	1	1	1	1	1	1	1	100%
5305	1	1	1	1	1	1	1	1	1	1	100%
5306	1	1	1	1	1	1	1	1	1	1	100%
5307	1	1	1	1	1	1	1	1	1	1	100%
5308	1	1	1	1	1	1	1	1	1	1	100%
5309	1	1	1	1	1	1	1	1	1	1	100%
5310	1	1	1	1	1	1	1	1	1	1	100%
5311	1	1	1	1	1	1	1	1	1	1	100%
5312	1	1	1	1	1	1	1	1	1	1	100%
5313	1	1	1	1	1	1	1	1	1	1	100%
5314	1	1	1	1	1	1	1	1	1	1	100%
5315	1	1	1	1	1	1	1	1	1	1	100%
5316	1	1	1	1	1	1	1	1	1	1	100%
5317	1	1	1	1	1	1	1	1	1	1	100%
5318	1	1	1	1	1	1	1	1	1	1	100%
5319	1	1	1	1	1	1	1	1	1	1	100%
5320	1	1	1	1	1	1	1	1	1	1	100%
5321	1	1	1	1	1	1	1	1	1	1	100%

5322	1	1	1	1	1	1	1	1	1	1	100%
5323	1	1	1	1	1	1	1	1	1	1	100%
5324	1	1	1	1	1	1	1	1	1	1	100%
5325	1	1	1	1	1	1	1	1	1	1	100%
5326	1	1	1	1	1	1	1	1	1	1	100%
5327	1	1	1	1	1	1	1	1	1	1	100%
5328	1	1	1	1	1	1	1	1	1	1	100%
5329 FH	1	1	1	1	1	1	1	1	1	1	100%
5330	0	0	0	0	0	0	0	0	0	0	0%
Detection Bandwidth = FH - FL = 5329MHz - 5292MHz = 37MHz											
EUT 99% Bandwidth = 36.26MHz (see note)											
UNII Detection Bandwidth Min. Limit (MHz): 36.26MHz x 100% = 36.26MHz											

Note: All UNII channels for this device have identical Channel bandwidths. Therefore, all DFS testing was done at 5310MHz. The 99% channel bandwidth is 36.30MHz. (See the 99% BW section of the RF report for further measurement details).



EUT Frequency=5290MHz for 802.11ac-VHT80											
Radar Frequency (MHz)	DFS Detection Trials (1=Detection, 0= No Detection)										Detection Rate (%)
	1	2	3	4	5	6	7	8	9	10	
5249	0	0	0	0	0	0	0	0	0	0	0%
5250 FL	1	1	1	1	1	1	1	1	1	1	100%
5251	1	1	1	1	1	1	1	1	1	1	100%
5252	1	1	1	1	1	1	1	1	1	1	100%
5253	1	1	1	1	1	1	1	1	1	1	100%
5254	1	1	1	1	1	1	1	1	1	1	100%
5255	1	1	1	1	1	1	1	1	1	1	100%
5256	1	1	1	1	1	1	1	1	1	1	100%
5257	1	1	1	1	1	1	1	1	1	1	100%
5258	1	1	1	1	1	1	1	1	1	1	100%
5259	1	1	1	1	1	1	1	1	1	1	100%
5260	1	1	1	1	1	1	1	1	1	1	100%
5261	1	1	1	1	1	1	1	1	1	1	100%
5262	1	1	1	1	1	1	1	1	1	1	100%
5263	1	1	1	1	1	1	1	1	1	1	100%
5264	1	1	1	1	1	1	1	1	1	1	100%
5265	1	1	1	1	1	1	1	1	1	1	100%
5266	1	1	1	1	1	1	1	1	1	1	100%
5267	1	1	1	1	1	1	1	1	1	1	100%
5268	1	1	1	1	1	1	1	1	1	1	100%
5269	1	1	1	1	1	1	1	1	1	1	100%
5270	1	1	1	1	1	1	1	1	1	1	100%
5271	1	1	1	1	1	1	1	1	1	1	100%
5272	1	1	1	1	1	1	1	1	1	1	100%
5273	1	1	1	1	1	1	1	1	1	1	100%
5274	1	1	1	1	1	1	1	1	1	1	100%
5275	1	1	1	1	1	1	1	1	1	1	100%
5276	1	1	1	1	1	1	1	1	1	1	100%
5277	1	1	1	1	1	1	1	1	1	1	100%

5278	1	1	1	1	1	1	1	1	1	1	100%
5279	1	1	1	1	1	1	1	1	1	1	100%
5280	1	1	1	1	1	1	1	1	1	1	100%
5281	1	1	1	1	1	1	1	1	1	1	100%
5282	1	1	1	1	1	1	1	1	1	1	100%
5283	1	1	1	1	1	1	1	1	1	1	100%
5284	1	1	1	1	1	1	1	1	1	1	100%
5285	1	1	1	1	1	1	1	1	1	1	100%
5286	1	1	1	1	1	1	1	1	1	1	100%
5287	1	1	1	1	1	1	1	1	1	1	100%
5288	1	1	1	1	1	1	1	1	1	1	100%
5289	1	1	1	1	1	1	1	1	1	1	100%
5290	1	1	1	1	1	1	1	1	1	1	100%
5291	1	1	1	1	1	1	1	1	1	1	100%
5292	1	1	1	1	1	1	1	1	1	1	100%
5293	1	1	1	1	1	1	1	1	1	1	100%
5294	1	1	1	1	1	1	1	1	1	1	100%
5295	1	1	1	1	1	1	1	1	1	1	100%
5296	1	1	1	1	1	1	1	1	1	1	100%
5297	1	1	1	1	1	1	1	1	1	1	100%
5298	1	1	1	1	1	1	1	1	1	1	100%
5299	1	1	1	1	1	1	1	1	1	1	100%
5300	1	1	1	1	1	1	1	1	1	1	100%
5301	1	1	1	1	1	1	1	1	1	1	100%
5302	1	1	1	1	1	1	1	1	1	1	100%
5303	1	1	1	1	1	1	1	1	1	1	100%
5304	1	1	1	1	1	1	1	1	1	1	100%
5305	1	1	1	1	1	1	1	1	1	1	100%
5306	1	1	1	1	1	1	1	1	1	1	100%
5307	1	1	1	1	1	1	1	1	1	1	100%
5308	1	1	1	1	1	1	1	1	1	1	100%
5309	1	1	1	1	1	1	1	1	1	1	100%
5310	1	1	1	1	1	1	1	1	1	1	100%
5311	1	1	1	1	1	1	1	1	1	1	100%

5312	1	1	1	1	1	1	1	1	1	1	100%
5313	1	1	1	1	1	1	1	1	1	1	100%
5314	1	1	1	1	1	1	1	1	1	1	100%
5315	1	1	1	1	1	1	1	1	1	1	100%
5316	1	1	1	1	1	1	1	1	1	1	100%
5317	1	1	1	1	1	1	1	1	1	1	100%
5318	1	1	1	1	1	1	1	1	1	1	100%
5319	1	1	1	1	1	1	1	1	1	1	100%
5320	1	1	1	1	1	1	1	1	1	1	100%
5321	1	1	1	1	1	1	1	1	1	1	100%
5322	1	1	1	1	1	1	1	1	1	1	100%
5323	1	1	1	1	1	1	1	1	1	1	100%
5324	1	1	1	1	1	1	1	1	1	1	100%
5325	1	1	1	1	1	1	1	1	1	1	100%
5326	1	1	1	1	1	1	1	1	1	1	100%
5327	1	1	1	1	1	1	1	1	1	1	100%
5328	1	1	1	1	1	1	1	1	1	1	100%
5329	1	1	1	1	1	1	1	1	1	1	100%
5330 FH	1	1	1	1	1	1	1	1	1	1	100%
5331	0	0	0	0	0	0	0	0	0	0	0%
Detection Bandwidth = FH - FL = 5330MHz - 5250MHz = 80MHz											
EUT 99% Bandwidth = 72.24MHz (see note)											
UNII Detection Bandwidth Min. Limit (MHz): 72.24MHz x 100% = 72.24MHz											

Note: All UNII channels for this device have identical Channel bandwidths. Therefore, all DFS testing was done at 5290MHz. The 99% channel bandwidth is 75.00MHz. (See the 99% BW section of the RF report for further measurement details).

## **5.5. Initial Channel Availability Check Time Measurement**

### **5.5.1. Test Limit**

The EUT shall perform a Channel Availability Check to ensure that there is no radar operating on the channel. After power-up sequence, receive at least 1 minute on the intended operating frequency.

### **5.5.2. Test Procedure**

1. The U-NII devices will be powered on and be instructed to operate on the appropriate U-NII Channel that must incorporate DFS functions. At the same time the EUT is powered on, the spectrum analyzer will be set to zero span mode with a 3 MHz RBW and 3 MHz VBW on the Channel occupied by the radar (Chr) with a 2.5 minute sweep time. The spectrum analyzer's sweep will be started at the same time power is applied to the U-NII device.
2. The EUT should not transmit any beacon or data transmissions until at least 1 minute after the completion of the power-on cycle.
3. Confirm that the EUT initiates transmission on the channel. Measurement system showing its nominal noise floor is marker1.

### 5.5.3. Test Result

The EUT does not transmit any beacon or data transmissions until at least 1 minute after the completion of the power-on cycle (121.7 sec). Initial beacons/data transmissions are indicated by marker 1 (181.7sec).

Initial Channel Availability Check Time for 802.11a

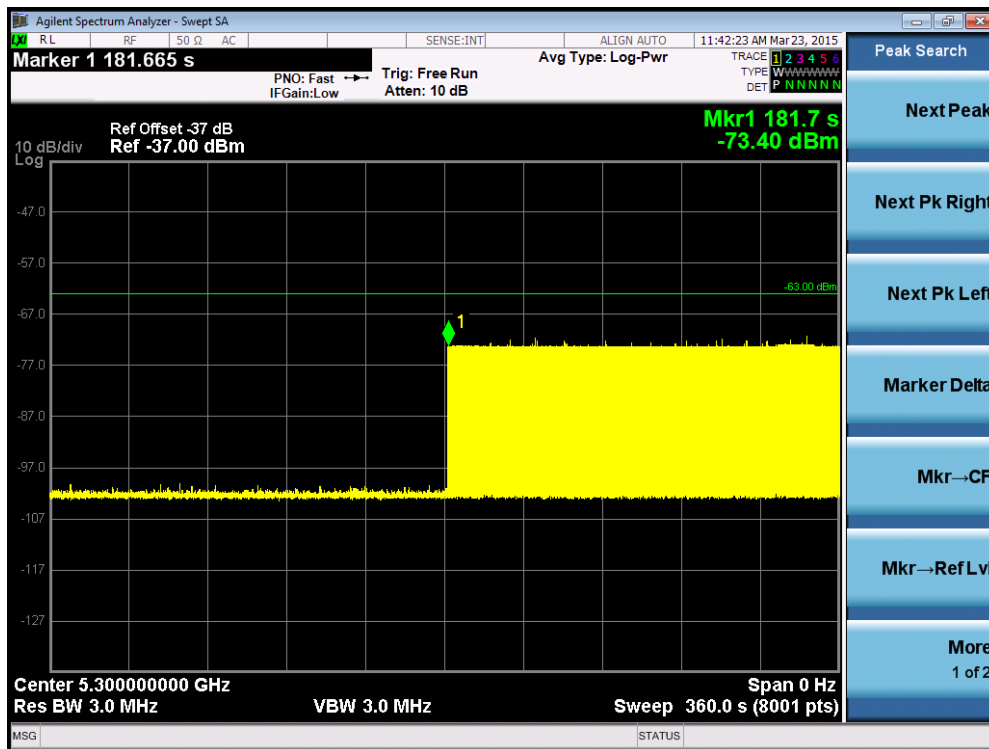

## **5.6. Radar Burst at the Beginning of the Channel Availability Check Time Measurement**

### **5.6.1. Test Limit**

In beginning of the Channel Availability Check (CAC) Time, radar is detected on this channel, select another intended channel and perform a CAC on that channel.

### **5.6.2. Test Procedure**

1. The steps below define the procedure to verify successful radar detection on the selected Channel during a period equal to the Channel Availability Check Time and avoidance of operation on that Channel when a radar Burst with a level equal to the DFS Detection Threshold + 1 dB occurs at the beginning of the Channel Availability Check Time.
2. The EUT is in completion power-up cycle (from T0 to T1). T1 denotes the instant when the EUT has completed its power-up sequence. The Channel Availability Check Time commences at instant T1 and will end no sooner than T1 + 60 seconds. A single Burst of one of Short Pulse Radar Types 0-4 at DFS Detection Threshold + 1 dB will commence within a 6 second window starting at T1.
3. Visual indication on the EUT of successful detection of the radar Burst will be recorded and reported. Observation of emissions at 5300MHz (for 802.11a) will continue for 2.5 minutes after the radar Burst has been generated. Verify that during the 2.5 minutes measurement window no EUT transmissions occurred at 5300MHz (for 802.11a).

### 5.6.3. Test Result

Radar Burst at the Beginning of the Channel Availability Check Time for 802.11a

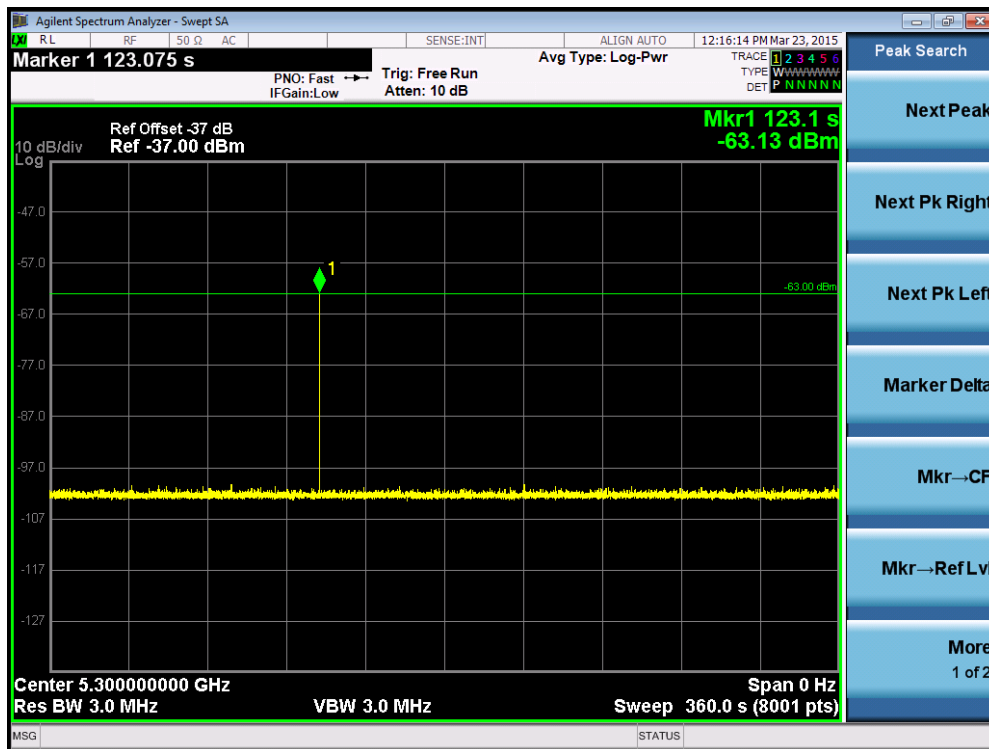

## **5.7. Radar Burst at the End of the Channel Availability Check Time Measurement**

### **5.7.1. Test Limit**

In the end of Channel Availability Check (CAC) Time, radar is detected on this channel, select another intended channel and perform a CAC on that channel.

### **5.7.2. Test Procedure**

1. The steps below define the procedure to verify successful radar detection on the selected Channel during a period equal to the Channel Availability Check Time and avoidance of operation on that Channel when a radar Burst with a level equal to the DFS Detection Threshold + 1 dB occurs at the beginning of the Channel Availability Check Time.
2. The EUT is powered on at T0. T1 denotes the instant when the EUT has completed its power-up sequence. The Channel Availability Check Time commences at instant T1 and will end no sooner than T1 + 60 seconds. A single Burst of one of Short Pulse Radar Types 0-4 at DFS Detection Threshold + 1 dB will commence within a 6 second window starting at T1+ 54 seconds.
3. Visual indication on the EUT of successful detection of the radar Burst will be recorded and reported. Observation of emissions at 5300MHz (for 802.11a) will continue for 2.5 minutes after the radar Burst has been generated. Verify that during the 2.5 minutes measurement window no EUT transmissions occurred at 5300MHz (for 802.11a).



### 5.7.3. Test Result

Radar Burst at the End of the Channel Availability Check Time for 802.11a

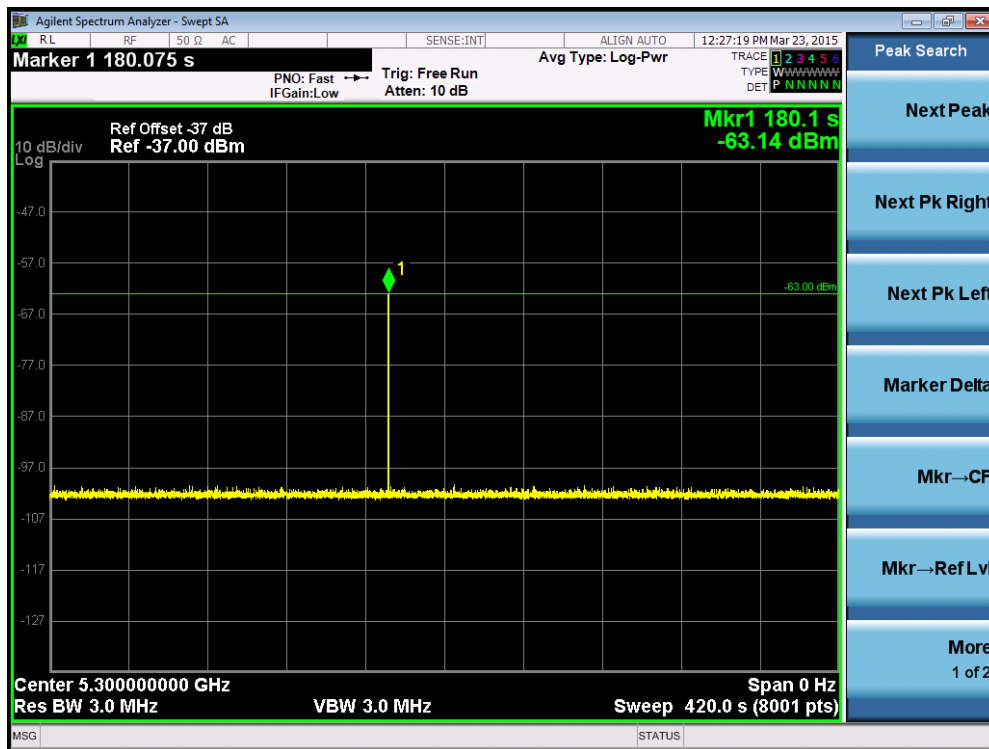

## 5.8. In-Service Monitoring for Channel Move Time, Channel Closing Transmission Time and Non-Occupancy Period Measurement

### 5.8.1. Test Limit

The EUT has In-Service Monitoring function to continuously monitor the radar signals. If the radar is detected, must leave the channel (Shutdown). The Channel Move Time to cease all transmissions on the current channel upon detection of a Radar Waveform above the DFS Detection Threshold within 10 sec. The total duration of Channel Closing Transmission Time is 260ms, consisting of data signals and the aggregate of control signals, by a U-NII device during the Channel Move Time. The Non-Occupancy Period time is 30 minute during which a Channel will not be utilized after a Radar Waveform is detected on that Channel.

### 5.8.2. Test Procedure Used

1. The test should be performed with Radar Type 0. The measurement timing begins at the end of the Radar Type 0.
2. When the radar burst with a level equal to the DFS Detection Threshold + 1dB is generated on the Operating Channel of the U-NII device. A U-NII device operating as a Master Device will associate with the Client Device at Channel. Stream the MPEG test file from the Master Device to the Client Device on the selected Channel for the entire period of the test. At time T0 the Radar Waveform generator sends a Burst of pulses for each of the radar types at Detection Threshold + 1dB.
3. Observe the transmissions of the EUT at the end of the radar Burst on the Operating Channel. Measure and record the transmissions from the EUT during the observation time (Channel Move Time).
4. Measurement of the aggregate duration of the Channel Closing Transmission Time method. With the spectrum analyzer set to zero span tuned to the center frequency of the EUT operating channel at the radar simulated frequency, peak detection, and max hold, the dwell time per bin is given by:  $Dwell (1.5ms) = S (12 \text{ sec}) / B (8000)$ ; where Dwell is the dwell time per spectrum analyzer sampling bin, S is the sweep time and B is the number of spectrum analyzer sampling bins. An upper bound of the aggregate duration of the intermittent control signals of Channel Closing Transmission Time is calculated by:  $80MHz: C (0 \text{ ms}) = N (0) \times Dwell (1.5 \text{ ms})$ ; where C is the Closing Time, N is the number of spectrum analyzer sampling bins showing a U-NII transmission and Dwell is the dwell time per bin.
5. Measure the EUT for more than 30 minutes following the channel close/move time to verify that the EUT does not resume any transmissions on this Channel.

### 5.8.3. Test Result

#### Channel Move Time and Channel Closing Transmission Time for 802.11ac-VHT80

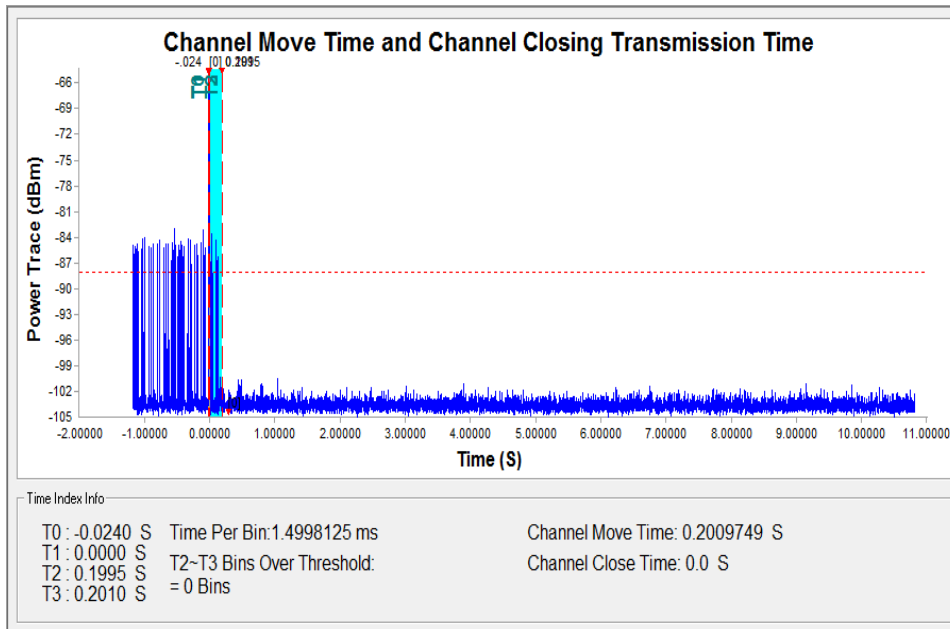
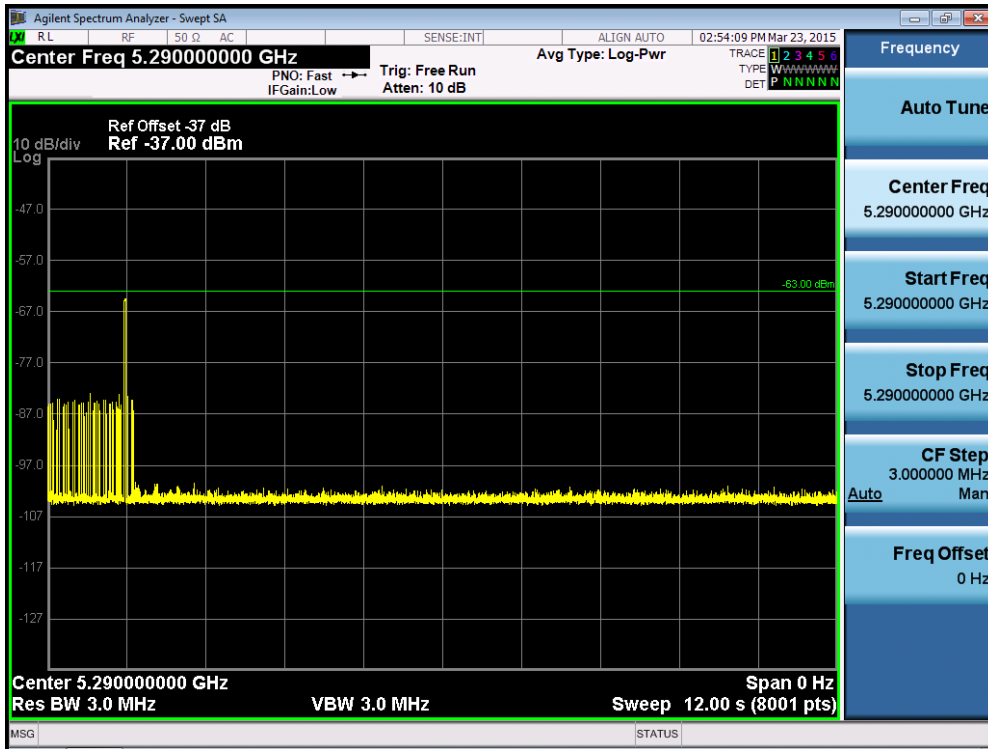

## Non-Occupancy Period for 802.11a

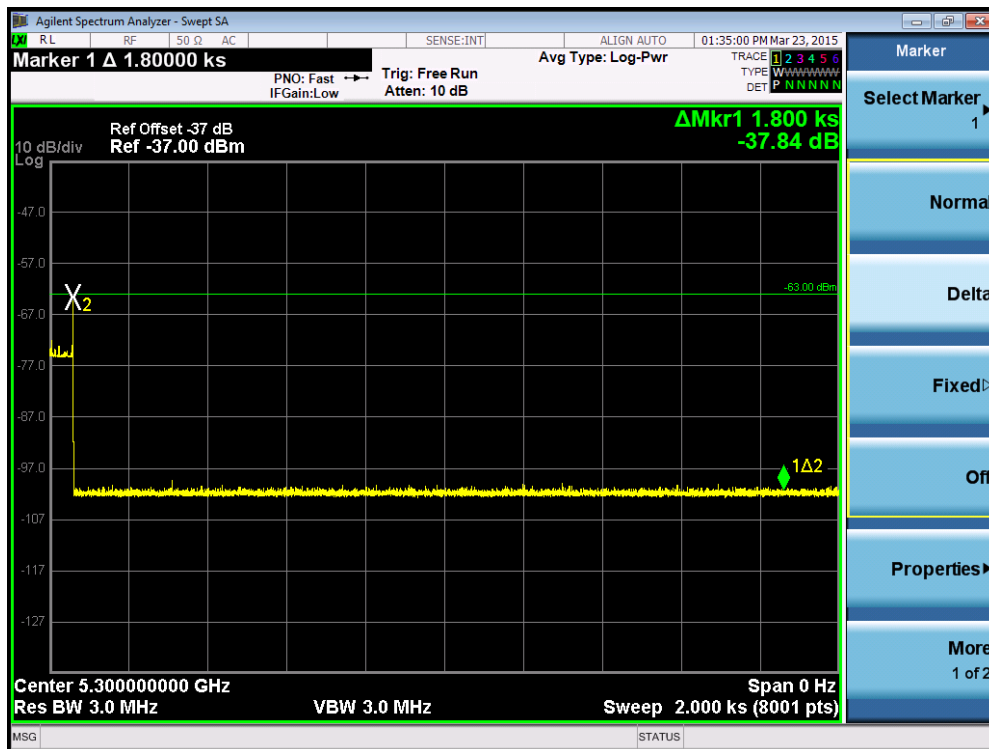

Parameter	Test Result	Limit
	Type 0	
Channel Move Time (s)	0.200s	<10s
Channel Closing Transmission Time (ms) (Note)	0ms	< 60ms
Non-Occupancy Period (min)	$\geq$ 30min	$\geq$ 30 min

Note: The Channel Closing Transmission Time is comprised of 200 milliseconds starting at the beginning of the Channel Move Time plus any additional intermittent control signals required to facilitate a Channel move (an aggregate of 60 milliseconds) during the remainder of the 10 seconds period. The aggregate duration of control signals will not count quiet periods in between transmissions.

## 5.9. Statistical Performance Check Measurement

### 5.9.1. Test Limit

The minimum percentage of successful detection requirements found in below table when a radar burst with a level equal to the DFS Detection Threshold + 1dB is generated on the Operating Channel of the U-NII device (In- Service Monitoring).

Radar Type	Minimum Number of Trails	Detection Probability
0	30	Pd > 60%
1	30(15 of test A and 15 of test B)	Pd > 60%
2	30	Pd > 60%
3	30	Pd > 60%
4	30	Pd > 60%
Aggregate (Radar Types 1-4)	120	Pd > 80%
5	30	Pd > 80%
6	30	Pd > 70%

The percentage of successful detection is calculated by:

$(\text{Total Waveform Detections} / \text{Total Waveform Trails}) * 100 = \text{Probability of Detection Radar}$

Waveform In addition an aggregate minimum percentage of successful detection across all Short Pulse Radar Types 1-4 is required and is calculated as follows:  $(Pd1 + Pd2 + Pd3 + Pd4) / 4$ .

### 5.9.2. Test Procedure

1. Stream the MPEG test file from the Master Device to the Client Device on the test Channel for the entire period of the test.
2. At time T0 the Radar Waveform generator sends the individual waveform for each of the Radar Types 1-6, at levels equal to the DFS Detection Threshold + 1dB, on the Operating Channel.
3. Observe the transmissions of the EUT at the end of the Burst on the Operating Channel for duration greater than 10 seconds for Short Pulse Radar Types 0 to ensure detection occurs.
4. Observe the transmissions of the EUT at the end of the Burst on the Operating Channel for duration greater than 22 seconds for Long Pulse Radar Type 5 to ensure detection occurs.
5. The device can utilize a test mode to demonstrate when detection occurs to prevent the need to reset the device between trial runs.
6. The Minimum number of trails, minimum percentage of successful detection and the average minimum percentage of successful detection are found in below table.

### 5.9.3. Test Result

Statistical Performance Check for 802.11a

Radar Type 1 - Radar Statistical Performance

Trail #	Test Freq. (MHz)	Pulse Width (us)	PRI (us)	Pulses / Burst	1=Detection 0=No Detection
1	5291	1	918	58	1
2	5291	1	518	102	1
3	5291	1	698	76	1
4	5291	1	838	63	1
5	5291	1	3066	18	1
6	5291	1	638	83	1
7	5291	1	578	92	1
8	5291	1	818	65	1
9	5291	1	798	67	1
10	5291	1	758	70	1
11	5291	1	558	95	1
12	5291	1	718	74	1
13	5291	1	778	68	1
14	5291	1	738	72	1
15	5291	1	938	57	1
16	5291	1	718	74	1
17	5291	1	2761	20	1
18	5291	1	2136	25	1
19	5291	1	3054	18	1
20	5291	1	936	57	1
21	5291	1	571	93	1
22	5291	1	1219	44	1
23	5291	1	2131	25	1
24	5291	1	1832	29	1
25	5291	1	1648	33	1
26	5291	1	834	64	1
27	5291	1	2684	20	1
28	5291	1	3024	18	1
29	5291	1	2799	19	1
30	5291	1	527	101	1
Detection Percentage (%)					100%

## Radar Type 2 - Radar Statistical Performance

Trail #	Test Freq. (MHz)	Pulse Width (us)	PRI (us)	Pulses / Burst	1=Detection 0=No Detection
1	5300	3.0	151	27	1
2	5300	3.0	230	27	1
3	5300	4.3	184	27	1
4	5300	2.2	218	23	1
5	5300	4.7	178	26	1
6	5300	1.9	184	25	1
7	5300	3.4	185	24	1
8	5300	3.0	212	26	1
9	5300	5.0	170	25	1
10	5300	2.3	168	27	1
11	5300	3.8	226	26	1
12	5300	2.9	189	25	1
13	5300	5.0	176	29	1
14	5300	1.9	187	26	1
15	5300	4.7	218	28	1
16	5300	4.2	184	26	1
17	5300	3.1	215	29	1
18	5300	3.0	196	23	1
19	5300	2.5	176	26	1
20	5300	3.9	154	24	1
21	5300	1.6	213	27	1
22	5300	2.9	172	27	1
23	5300	4.3	156	29	1
24	5300	3.3	219	27	1
25	5300	2.8	230	27	1
26	5300	2.3	167	24	1
27	5300	3.7	230	26	1
28	5300	4.2	186	29	1
29	5300	1.0	158	27	1
30	5300	2.3	193	29	1
Detection Percentage (%)					100%

## Radar Type 3 - Radar Statistical Performance

Trail #	Test Freq. (MHz)	Pulse Width (us)	PRI (us)	Pulses / Burst	1=Detection 0=No Detection
1	5309	8.9	328	18	1
2	5309	8.1	462	17	1
3	5309	6.6	396	16	1
4	5309	8.7	344	17	1
5	5309	10.0	325	16	1
6	5309	6.1	471	16	1
7	5309	6.2	290	16	1
8	5309	9.7	408	17	1
9	5309	6.3	395	18	1
10	5309	7.3	453	18	1
11	5309	8.4	399	17	1
12	5309	7.2	368	18	1
13	5309	6.9	499	18	1
14	5309	7.2	491	18	1
15	5309	9.3	260	17	1
16	5309	7.6	292	17	1
17	5309	9.0	306	17	1
18	5309	8.0	261	16	1
19	5309	7.0	334	17	1
20	5309	6.3	347	18	1
21	5309	6.8	460	17	1
22	5309	6.7	294	16	1
23	5309	8.8	431	16	1
24	5309	8.3	257	16	0
25	5309	9.9	442	18	1
26	5309	9.1	494	18	1
27	5309	9.9	286	18	1
28	5309	8.8	348	18	1
29	5309	9.5	408	16	1
30	5309	6.5	500	16	1
Detection Percentage (%)					96.7%



## Radar Type 4 - Radar Statistical Performance

Trail #	Test Freq. (MHz)	Pulse Width (us)	PRI (us)	Pulses / Burst	1=Detection 0=No Detection
1	5291	14.0	363	14	1
2	5291	14.7	268	13	1
3	5291	17.8	450	14	1
4	5291	13.1	264	14	1
5	5291	17.7	251	13	1
6	5291	11.2	348	15	1
7	5291	13.6	343	16	1
8	5291	19.3	500	13	1
9	5291	15.1	497	15	1
10	5291	13.0	376	16	1
11	5291	14.2	302	12	1
12	5291	13.5	281	12	1
13	5291	20.0	440	12	1
14	5291	12.7	258	16	1
15	5291	15.8	282	14	1
16	5291	11.8	251	15	1
17	5291	14.9	405	15	1
18	5291	12.1	388	12	1
19	5291	17.6	395	15	1
20	5291	16.9	403	15	1
21	5291	18.0	416	12	1
22	5291	14.8	472	12	1
23	5291	13.0	301	13	1
24	5291	14.0	379	16	1
25	5291	14.0	283	12	1
26	5291	15.1	338	15	1
27	5291	12.4	393	13	1
28	5291	18.1	337	15	1
29	5291	19.4	387	12	1
30	5291	16.1	283	15	0
Detection Percentage (%)					96.7%

Note: In addition an average minimum percentage of successful detection across all four Short pulse radar test

waveforms is as follows:  $\frac{P_d1 + P_d2 + P_d3 + P_d4}{4} = (100\% + 100\% + 96.7\% + 96.7\%) / 4 = 98.35\% (>80\%)$



Radar Type 5 - Radar Statistical Performance

Trail #	Test Freq. (MHz)	1=Detection 0=No Detection	Trail #	Test Freq. (MHz)	1=Detection 0=No Detection
1	5492	1	16	5507	1
2	5493	1	17	5508	1
3	5494	1	18	5492	1
4	5495	1	19	5493	1
5	5496	1	20	5494	1
6	5497	1	21	5495	1
7	5498	1	22	5496	1
8	5499	1	23	5497	1
9	5500	1	24	5498	1
10	5501	1	25	5499	1
11	5502	1	26	5500	1
12	5503	1	27	5501	1
13	5504	1	28	5502	1
14	5505	1	29	5503	1
15	5506	1	30	5504	1
Detection Percentage (%)					100%

Type 5 Radar Waveform_1												
Waveform Num = 1	Num of Bursts = 20	Burst Interval (us) = 600000	Off Time (us)	# Pulses	Chirp (MHz)	PW (us)	Pulse 1 Pri (us)	Pulse 2 Pri (us)	Pulse 3 Pri (us)	Start Loc (us)	Start Burst Interval (us)	End Burst Interval (us)
1	255817	1	5	90	1423	0	265817	0	0	265817	0	699999
2	693820	3	10	60	1050	1426	961050	1426	1051	961050	600000	1199999
3	725012	2	18	90	1656	1235	1689599	1235	0	1689599	1200000	1799999
4	658160	2	15	65	1180	1493	2350650	1493	0	2350650	1800000	2399999
5	415482	2	13	90	1594	1319	2768805	1319	0	2768805	2400000	2999999
6	300869	3	20	65	1353	1680	3072587	1680	1992	3072587	3000000	3599999
7	891087	3	10	90	1626	1202	3968699	1202	1220	3968699	3600000	4199999
8	307715	1	9	75	1432	0	4280452	0	0	4280452	4200000	4799999
9	999311	2	16	95	1264	1939	5281205	1939	0	5281205	4800000	5399999
10	290004	1	18	70	1572	0	5574412	0	0	5574412	5400000	5999999
11	708697	3	12	70	1650	1689	6284681	1689	1148	6284681	6000000	6599999
12	405512	1	14	75	1856	0	6694680	0	0	6694680	6600000	7199999
13	590693	3	12	60	1476	1126	7287229	1126	1840	7287229	7200000	7799999
14	557156	2	8	95	1888	1520	7848827	1520	0	7848827	7800000	8399999
15	963122	1	18	80	1244	0	8815357	0	0	8815357	8400000	8999999
16	255199	3	9	85	1472	1731	9071800	1731	1374	9071800	9000000	9599999
17	703288	1	8	75	1077	0	9779665	0	0	9779665	9600000	10199999
18	1013435	1	18	65	1857	0	10794177	0	0	10794177	10200000	10799999
19	292189	1	9	80	1318	0	11088223	0	0	11088223	10800000	11399999
20	366637	1	15	100	1519	0	11456178	0	0	11456178	11400000	11999999
Total number of pulses in waveform = 37												
*****												