



DFS MEASUREMENT REPORT

FCC PART 15.407

FCC ID: 2ABLK-844E-1

APPLICANT: Calix Inc.

Application Type: Certification

Product: WiFi Concurrent 4 Port GE LAN VoIP Ethernet Gateway with USB

Model No.: 844E-1

Brand Name: Calix

FCC Classification: Unlicensed National Information Infrastructure (UNII)

FCC Rule Part(s): Part 15.407
KDB 905462 D02v01r01, KDB 905462 D04v01

Type of Device: Master Device
 Client Device (No radar detection)
 Client Device with radar detection

Test Date: Jan 16~ Feb. 21, 2015

Reviewed By : Robin Wu
(Robin Wu)

Approved By : Marlin Chen
(Marlin Chen)



The test results relate only to the samples tested.

This equipment has been shown to be capable of compliance with the applicable technical standards as indicated in the measurement report and was tested in accordance with the measurement procedures specified in KDB 905462 D02v01r01. Test results reported herein relate only to the item(s) tested.

The test report shall not be reproduced except in full without the written approval of MRT Technology (Suzhou) Co., Ltd.

Revision History

Report No.	Version	Description	Issue Date
1501RSU00603	Rev. 01	Initial report	03-21-2015

CONTENTS

Description	Page
Revision History	2
§2.1033 General Information	5
1. INTRODUCTION	6
1.1. Scope	6
1.2. MRT Test Location	6
2. PRODUCT INFORMATION	7
2.1. Equipment Description	7
2.2. Description of Available Antennas.....	8
2.1. Description of Antenna RF Port.....	9
2.2. DFS Band Carrier Frequencies Operation	10
2.3. Test Mode	11
3. DFS DETECTION THRESHOLDS AND RADAR TEST WAVEFORMS	12
3.1. Applicability	12
3.2. DFS Devices Requirements	13
3.3. DFS Detection Threshold Values	14
3.4. Parameters of DFS Test Signals	15
3.5. Conducted Test Setup	18
4. TEST EQUIPMENT CALIBRATION DATE	19
5. TEST RESULT	20
5.1. Summary	20
5.2. Radar Waveform Calibration	21
5.2.1. Calibration Setup.....	21
5.2.2. Calibration Procedure.....	21
5.2.3. Cablibration Result	22
5.2.4. Test Setup Photo	错误! 未定义书签。
5.3. Channel Loading Test Result	26
5.4. UNII Detection Bandwidth Measurement	28
5.4.1. Test Limit	28
5.4.2. Test Procedure	28
5.4.3. Test Result.....	29
5.5. Initial Channel Availability Check Time Measurement	37
5.5.1. Test Limit	37
5.5.2. Test Procedure	37

5.5.3. Test Result.....	38
5.6. Radar Burst at the Beginning of the Channel Availability Check Time Measurement ...	39
5.6.1. Test Limit	39
5.6.2. Test Procedure	39
5.6.3. Test Result.....	40
5.7. Radar Burst at the End of the Channel Availability Check Time Measurement	41
5.7.1. Test Limit	41
5.7.2. Test Procedure	41
5.7.3. Test Result.....	42
5.8. In-Service Monitoring for Channel Move Time, Channel Closing Transmission Time and Non-Occupancy Period Measurement	43
5.8.1. Test Limit	43
5.8.2. Test Procedure Used.....	43
5.8.3. Test Result.....	44
5.9. Statistical Performance Check Measurement	46
5.9.1. Test Limit	46
5.9.2. Test Procedure	46
5.9.3. Test Result.....	47
6. CONCLUSION.....	128

§2.1033 General Information

Applicant:	Calix Inc.
Applicant Address:	1035 N. McDowell Blvd Petaluma, CA94954 U.S.A
Manufacturer:	Wuxi Mitrastar Technology Co.,Ltd
Manufacturer Address:	60#-E, Minshan Road, New District Wuxi
Test Site:	MRT Technology (Suzhou) Co., Ltd
Test Site Address:	D8 Building, Youxin Industrial Park, No.2 Tian'edang Rd., Wuzhong Economic Development Zone, Suzhou, China
MRT FCC Registration No.:	809388
Model No.:	844E-1
FCC ID:	2ABLK-844E-1
Test Device Serial No.:	N/A <input type="checkbox"/> Production <input checked="" type="checkbox"/> Pre-Production <input type="checkbox"/> Engineering
FCC Classification:	Unlicensed National Information Infrastructure (UNII)

Test Facility / Accreditations

Measurements were performed at MRT Laboratory located in Tian'edang Rd., Suzhou, China.

- MRT facility is a FCC registered (MRT Reg. No. 809388) test facility with the site description report on file and has met all the requirements specified in Section 2.948 of the FCC Rules.
- MRT facility is an IC registered (MRT Reg. No. 11384A-1) test laboratory with the site description on file at Industry Canada.
- MRT facility is a VCCI registered (R-4179, G-814, C-4664, T-2206) test laboratory with the site description on file at VCCI Council.
- MRT Lab is accredited to ISO 17025 by the American Association for Laboratory Accreditation (A2LA) under the American Association for Laboratory Accreditation Program (A2LA Cert. No. 3628.01) in EMC, Telecommunications and Radio testing for FCC, Industry Canada, EU and TELEC Rules.



1. INTRODUCTION

1.1. Scope

Measurement and determination of electromagnetic emissions (EMC) of radio frequency devices including intentional and/or unintentional radiators for compliance with the technical rules and regulations of the Federal Communications Commission and the Industry Canada Certification and Engineering Bureau.

1.2. MRT Test Location

The map below shows the location of the MRT LABORATORY, its proximity to the Taihu Lake. These measurement tests were conducted at the MRT Technology (Suzhou) Co., Ltd. Facility located at D8 Building, Youxin Industrial Park, No.2 Tian'edang Rd., Wuzhong Economic Development Zone, Suzhou, China. The detailed description of the measurement facility was found to be in compliance with the requirements of § 2.948 according to ANSI C63.4-2009 on September 30, 2013.



2. PRODUCT INFORMATION

2.1. Equipment Description

Product Name	WiFi Concurrent 4 Port GE LAN VoIP Ethernet Gateway with USB
Model No.	844E-1
Radio Type	Intentional Transceiver
Operation Mode	Master Device
Frequency Range	<p>For 802.11a/n-HT20: 5260~5320MHz, 5500~5700MHz</p> <p>For 802.11ac-VHT20: 5260~5320MHz, 5500~5720MHz</p> <p>For 802.11n-HT40: 5270~5310MHz, 5510~5670MHz</p> <p>For 802.11ac-VHT40: 5270~5310MHz, 5510~5710MHz</p> <p>For 802.11ac-VHT80: 5290MHz, 5530MHz, 5610MHz, 5690MHz</p>
Maximum Output Power	<p>802.11a: 21.12dBm</p> <p>802.11n-HT20: 21.24dBm</p> <p>802.11ac-VHT20: 21.23dBm</p> <p>802.11n-HT40: 21.16dBm</p> <p>802.11ac-VHT40: 21.27dBm</p> <p>802.11ac-VHT80: 21.04dBm</p>
Type of Modulation	802.11a/n/ac: OFDM;
Power-on cycle	Requires 180.9 seconds to complete its power-on cycle.
Uniform Spreading	For the 5250-5350MHz, 5470-5725 MHz bands, the Master device provides, on aggregate, uniform loading of the spectrum across all devices by selecting an operating channel among the available channels using a random algorithm.

2.2. Description of Available Antennas

Antenna Type	Frequency Band (GHz)	T _x Paths	Directional Gain (dBi)		
			Non Beam Forming	Beam Forming	CDD
PCB Antenna	2.4	2	1.90	--	--
	5.2	4	2.17	8.04	8.04
	5.3	4	2.03	7.78	7.78
	5.6	4	2.55	8.38	8.38
	5.8	4	2.70	8.70	8.70

Note:

- Transmit at 2.4GHz support two antennas, and support four antennas at 5GHz transmit.
- The EUT working on Beam Forming mode, and the Beam Forming support 802.11n/ac, not include 802.11a, and 802.11a working on CDD mode.
- Correlated signals include, but are not limited to, signals transmitted in any of the following modes:
 - Any transmit Beam Forming mode, whether fixed or adaptive (e.g., phased array modes, closed loop MIMO modes, Transmitter Adaptive Antenna modes, Maximum Ratio Transmission (MRT) modes, and Statistical Eigen Beam Forming (EBF) modes).
- Unequal antenna gains, with equal transmit powers. For antenna gains given by G_1, G_2, \dots, G_N dBi
 - transmit signals are correlated, then
 - Directional gain = $10 \log[(10^{G_1/20} + 10^{G_2/20} + \dots + 10^{G_N/20})^2 / N_{ANT}]$ dBi [Note the "20"s in the denominator of each exponent and the square of the sum of terms; the object is to combine the signal levels coherently.]

2.1. Description of Antenna RF Port

RF Port				
Test Mode	Software Control Port			
2.4GHz T _x	Ant 0	Ant 1	--	--
Test Mode	Software Control Port			
5GHz T _x	Ant 0	Ant 1	Ant 2	Ant 3

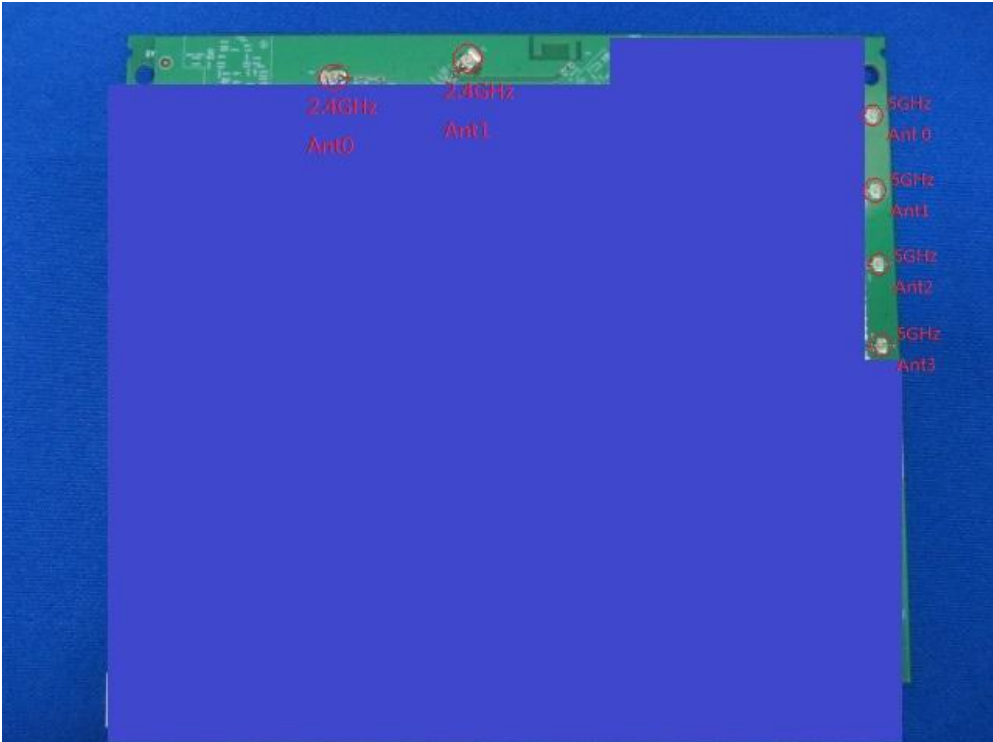

2.2. DFS Band Carrier Frequencies Operation

802.11a/n Center Working Frequency of Each Channel

Channel	Frequency	Channel	Frequency	Channel	Frequency
52	5260 MHz	56	5280 MHz	60	5300 MHz
64	5320 MHz	100	5500 MHz	104	5520 MHz
108	5540 MHz	112	5560 MHz	116	5580 MHz
120	5600 MHz	124	5620 MHz	128	5640 MHz
132	5660 MHz	136	5680 MHz	140	5700 MHz

802.11ac-VHT20 Center Working Frequency of Each Channel

Channel	Frequency	Channel	Frequency	Channel	Frequency
52	5260 MHz	56	5280 MHz	60	5300 MHz
64	5320 MHz	100	5500 MHz	104	5520 MHz
108	5540 MHz	112	5560 MHz	116	5580 MHz
120	5600 MHz	124	5620 MHz	128	5640 MHz
132	5660 MHz	136	5680 MHz	140	5700 MHz
144	5720 MHz	N/A	N/A	N/A	N/A

802.11n-HT40 Center Working Frequency of Each Channel

Channel	Frequency	Channel	Frequency	Channel	Frequency
54	5270 MHz	62	5310 MHz	102	5510 MHz
110	5550 MHz	118	5590 MHz	126	5630 MHz
134	5670 MHz	N/A	N/A	N/A	N/A

802.11ac-VHT40 Center Working Frequency of Each Channel

Channel	Frequency	Channel	Frequency	Channel	Frequency
54	5270 MHz	62	5310 MHz	102	5510 MHz
110	5550 MHz	118	5590 MHz	126	5630 MHz
134	5670 MHz	142	5710MHz	N/A	N/A

802.11ac-VHT80 Center Working Frequency of Each Channel

Channel	Frequency	Channel	Frequency	Channel	Frequency
58	5290 MHz	106	5530 MHz	122	5610 MHz
138	5690 MHz	N/A	N/A	N/A	N/A

2.3. Test Mode

Test Mode	Mode 1: Communication with Notebook
-----------	-------------------------------------

3. DFS DETECTION THRESHOLDS AND RADAR TEST WAVEFORMS

3.1. Applicability

The following table e from FCC KDB 905462 D02 UNII DFS Compliance Procedures New Rules v01r01 lists the applicable requirements for the DFS testing.

Requirement	Operational Mode		
	Master	Client Without Radar Detection	Client With Radar Detection
Non-Occupancy Period	Yes	Not required	Yes
DFS Detection Threshold	Yes	Not required	Yes
Channel Availability Check Time	Yes	Not required	Not required
U-NII Detection Bandwidth	Yes	Not required	Yes

Table 3-1: Applicability of DFS Requirements Prior to Use of a Channel

Requirement	Operational Mode	
	Master Device or Client With Radar Detection	Client Without Radar Detection
DFS Detection Threshold	Yes	Not required
Channel Closing Transmission Time	Yes	Yes
Channel Move Time	Yes	Yes
U-NII Detection Bandwidth	Yes	Not required

Additional requirements for devices with multiple bandwidth modes	Master Device or Client with Radar Detection	Client Without Radar Detection
U-NII Detection Bandwidth and Statistical Performance Check	All BW modes must be tested	Not required
Channel Move Time and Channel Closing Transmission Time	Test using widest BW mode available	Test using the widest BW mode available for the link
All other tests	Any single BW mode	Not required

Note: Frequencies selected for statistical performance check should include several frequencies within the radar detection bandwidth and frequencies near the edge of the radar detection bandwidth. For 802.11 devices it is suggested to select frequencies in each of the bonded 20 MHz channels and the channel center frequency.

Table 3-2: Applicability of DFS Requirements during normal operation

3.2. DFS Devices Requirements

Per FCC KDB 905462 D02 UNII DFS Compliance Procedures New Rules v01r01 the following are the requirements for Master Devices:

- (a) The Master Device will use DFS in order to detect Radar Waveforms with received signal strength above the DFS Detection Threshold in the 5250 ~ 5350 MHz and 5470 ~ 5725 MHz bands. DFS is not required in the 5150 ~ 5250 MHz or 5725 ~ 5825 MHz bands.
- (b) Before initiating a network on a Channel, the Master Device will perform a Channel Availability Check for a specified time duration (Channel Availability Check Time) to ensure that there is no radar system operating on the Channel, using DFS described under subsection a) above.
- (c) The Master Device initiates a U-NII network by transmitting control signals that will enable other U-NII devices to Associate with the Master Device.
- (d) During normal operation, the Master Device will monitor the Channel (In-Service Monitoring) to ensure that there is no radar system operating on the Channel, using DFS described under a).
- (e) If the Master Device has detected a Radar Waveform during In-Service Monitoring as described under d), the Operating Channel of the U-NII network is no longer an Available Channel. The Master Device will instruct all associated Client Device(s) to stop transmitting on this Channel within the Channel Move Time. The transmissions during the Channel Move Time will be limited to the Channel Closing Transmission Time.
- (f) Once the Master Device has detected a Radar Waveform it will not utilize the Channel for the duration of the Non-Occupancy Period.
- (g) If the Master Device delegates the In-Service Monitoring to a Client Device, then the combination will be tested to the requirements described under d) through f) above.

Channel Move Time and Channel Closing Transmission Time requirements are listed in the following table.

Parameter	Value
Non-occupancy period	Minimum 30 minutes
Channel Availability Check Time	60 seconds
Channel Move Time	10 seconds See Note 1.
Channel Closing Transmission Time	200 milliseconds + an aggregate of 60 milliseconds over remaining 10 second period. See Notes 1 and 2.
U-NII Detection Bandwidth	Minimum 100% of the U-NII 99% transmission power bandwidth. See Note 3.
Note 1: Channel Move Time and the Channel Closing Transmission Time should be performed with	

Radar Type 0. The measurement timing begins at the end of the Radar Type 0 burst.

Note 2: The Channel Closing Transmission Time is comprised of 200 milliseconds starting at the beginning of the Channel Move Time plus any additional intermittent control signals required to facilitate a Channel move (an aggregate of 60 milliseconds) during the remainder of the 10 second period. The aggregate duration of control signals will not count quiet periods in between transmissions.

Note 3: During the U-NII Detection Bandwidth detection test, radar type 0 should be used. For each frequency step the minimum percentage of detection is 90 percent. Measurements are performed with no data traffic.

Table 3-3: DFS Response Requirements

3.3. DFS Detection Threshold Values

The DFS detection thresholds are defined for Master devices and Client Devices with In-service monitoring. These detection thresholds are listed in the following table.

Maximum Transmit Power	Value (See Notes 1, 2, and 3)
EIRP ≥ 200 milliwatt	-64 dBm
EIRP < 200 milliwatt and power spectral density < 10 dBm/MHz	-62 dBm
EIRP < 200 milliwatt that do not meet the power spectral density requirement	-64 dBm
<p>Note 1: This is the level at the input of the receiver assuming a 0 dBi receive antenna.</p> <p>Note 2: Throughout these test procedures an additional 1 dB has been added to the amplitude of the test transmission waveforms to account for variations in measurement equipment. This will ensure that the test signal is at or above the detection threshold level to trigger a DFS response.</p> <p>Note3: EIRP is based on the highest antenna gain. For MIMO devices refer to KDB Publication 662911 D01.</p>	

Table 3-4: Detection Thresholds for Master Devices and Client Devices with Radar Detection

3.4. Parameters of DFS Test Signals

This section provides the parameters for required test waveforms, minimum percentage of successful detections, and the minimum number of trials that must be used for determining DFS conformance. Step intervals of 0.1 microsecond for Pulse Width, 1 microsecond for PRI, 1 MHz for chirp width and 1 for the number of pulses will be utilized for the random determination of specific test waveforms.

Short Pulse Radar Test Waveforms

Radars Type	Pulse Width (μsec)	PRI (μsec)	Number of Pulses	Minimum Percentage of Successful Detection	Minimum Number of Trials
0	1	1428	18	See Note 1	See Note 1
1	1	Test A: 15 unique PRI values randomly selected from the list of 23 PRI values in Table 3-6	$\text{Roundup} \left\{ \left(\frac{1}{360} \right), \left(\frac{19 \cdot 10^6}{\text{PRI}_{\mu\text{sec}}} \right) \right\}$	60%	30
		Test B: 15 unique PRI values randomly selected within the range of 518-3066 μsec, with a minimum increment of 1 μsec, excluding PRI values selected in Test A			
2	1-5	150-230	23-29	60%	30
3	6-10	200-500	16-18	60%	30
4	11-20	200-500	12-16	60%	30
Aggregate (Radars Types 1-4)				80%	120
Note 1: Short Pulse Radar Type 0 should be used for the detection bandwidth test, channel move time, and channel closing time tests.					

Table 3-5: Parameters for Short Pulse Radar Waveforms

A minimum of 30 unique waveforms are required for each of the Short Pulse Radar Types 2 through 4. If more than 30 waveforms are used for Short Pulse Radar Types 2 through 4, then each additional waveform must also be unique and not repeated from the previous waveforms.

Pulse Repetition Frequency Number	Pulse Repetition Frequency (Pulses Per Second)	Pulse Repetition Interval (Microseconds)
1	1930.5	518
2	1858.7	538
3	1792.1	558
4	1730.1	578
5	1672.2	598
6	1618.1	618
7	1567.4	638
8	1519.8	658
9	1474.9	678
10	1432.7	698
11	1392.8	718
12	1355	738
13	1319.3	758
14	1285.3	778
15	1253.1	798
16	1222.5	818
17	1193.3	838
18	1165.6	858
19	1139	878
20	1113.6	898
21	1089.3	918
22	1066.1	938
23	326.2	3066

Table 3-6: Pulse Repetition Intervals Values for Test A

Long Pulse Radar Test Waveform

Radar Type	Pulse Width (μsec)	Chirp Width (MHz)	PRI (μsec)	Number of Pulses per Burst	Number of Bursts	Minimum Percentage of Successful Detection	Minimum Number of Trials
5	50 - 100	5 - 20	1000 - 2000	1 - 3	8 - 20	80%	30

Table 3-7: Parameters for Long Pulse Radar Waveforms

The parameters for this waveform are randomly chosen. Thirty unique waveforms are required for the Long Pulse Radar Type waveforms. If more than 30 waveforms are used for the Long Pulse Radar Type waveforms, then each additional waveform must also be unique and not repeated from the previous waveforms.

Frequency Hopping Radar Test Waveform

Radar Type	Pulse Width (μsec)	PRI (μsec)	Pulses Per Hop	Hopping Rate (kHz)	Hopping Sequence Length (msec)	Minimum Percentage of Successful Detection	Minimum Number of Trials
6	1	333	9	0.333	300	70%	30

Table 3-8: Parameters for Frequency Hopping Radar Waveforms

For the Frequency Hopping Radar Type, the same Burst parameters are used for each waveform. The hopping sequence is different for each waveform and a 100-length segment is selected from the hopping sequence defined by the following algorithm:

The first frequency in a hopping sequence is selected randomly from the group of 475 integer frequencies from 5250 – 5724MHz. Next, the frequency that was just chosen is removed from the group and a frequency is randomly selected from the remaining 474 frequencies in the group. This process continues until all 475 frequencies are chosen for the set. For selection of a random frequency, the frequencies remaining within the group are always treated as equally likely.

3.5. Conducted Test Setup

The FCC KDB 905462 D02 UNII DFS Compliance Procedures New Rules v01r01 describes a radiated test setup and a conducted test setup. The conducted test setup was used for this testing. Figure 3-1 shows the typical test setup.

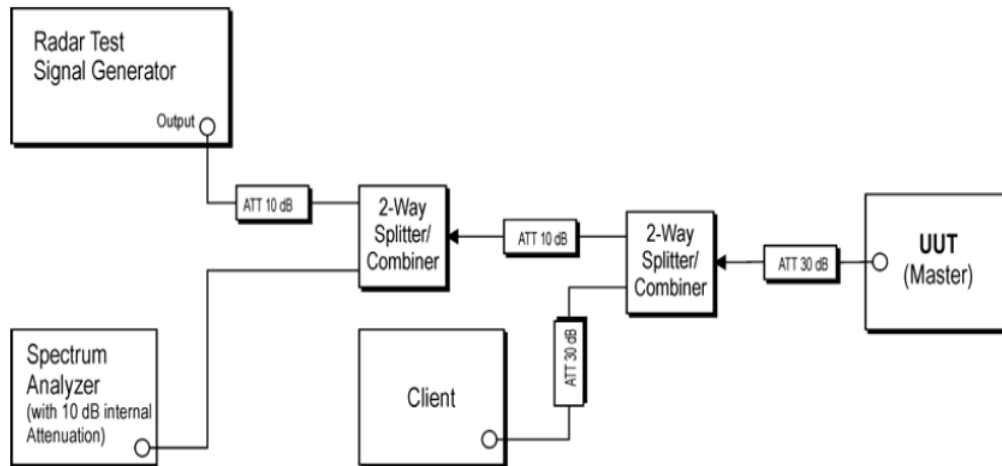

Figure 3-1: Conducted Test Setup where UUT is a Master and Radar Test Waveforms are injected into the Masters

4. TEST EQUIPMENT CALIBRATION DATE

Dynamic Frequency Selection (DFS)

Instrument	Manufacturer	Type No.	Serial No.	Cali. Due Date
Spectrum Analyzer	Agilent	N9020A	MY52090106	2015/04/23
ESG Vector Signal Generator	Agilent	E4438C	MY49872484	2015/12/09

Software	Manufacturer	Function
Pulse Building	Agilent	Radar Signal Generation Software
DFS Tool	Agilent	DFS Test Software

5. TEST RESULT

5.1. Summary

Company Name: Calix Inc.
FCC ID: 2ABLK-844E-1
FCC Classification: Unlicensed National Information Infrastructure (UNII)

Parameter	Limit	Test Result	Reference
UNII Detection Bandwidth Measurement	Refer Table 3-3	Pass	Section 5.4
Initial Channel Availability Check Time	Refer Table 3-3	Pass	Section 5.5
Radar Burst at the Beginning of the Channel Availability Check Time	Refer Table 3-3	Pass	Section 5.6
Radar Burst at the End of the Channel Availability Check Time	Refer Table 3-3	Pass	Section 5.7
In-Service Monitoring for Channel Move Time, Channel Closing Transmission Time	Refer Table 3-3	Pass	Section 5.8
Non-Occupancy Period	Refer Table 3-3	Pass	Section 5.8
Statistical Performance Check	Refer Table 3-3	Pass	Section 5.9

5.2. Radar Waveform Calibration

5.2.1. Calibration Setup

The conducted test setup was used for this calibration testing. Figure 3-2 shows the typical test setup.

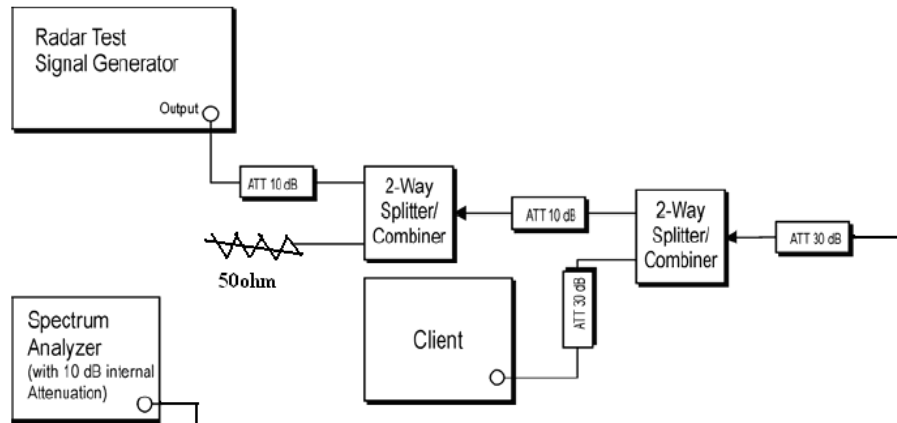

Figure 3-2: Conducted Test Setup

5.2.2. Calibration Procedure

The Interference Radar Detection Threshold Level is $(-64\text{dBm}) + (0) [\text{dBi}] + 1 \text{ dB} = -63 \text{ dBm}$ that had been taken into account the output power range and antenna gain. The above equipment setup was used to calibrate the conducted Radar Waveform. A vector signal generator was utilized to establish the test signal level for each radar type. During this process there were replace 50ohm terminal form Master and Client device and no transmissions by either the Master or Client Device. The spectrum analyzer was switched to the zero span (Time Domain) at the frequency of the Radar Waveform generator. Peak detection was used. The spectrum analyzer resolution bandwidth (RBW) and video bandwidth (VBW) were set to at least 3MHz. The vector signal generator amplitude was set so that the power level measured at the spectrum analyzer was $(-64\text{dBm}) + (0) [\text{dBi}] + 1 \text{ dB} = -63\text{dBm}$. Capture the spectrum analyzer plots on short pulse radar types, long pulse radar type and hopping radar waveform.

5.2.3. Cablibration Result

Radar #0 DFS detection threshold level and the burst of pulses on the Channel frequency

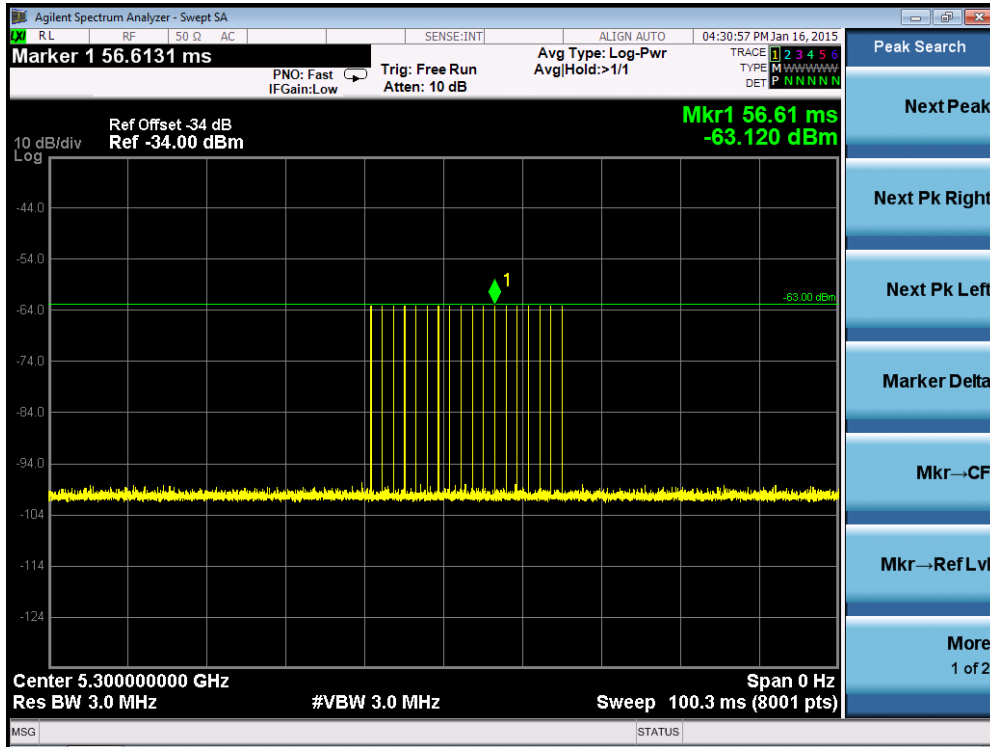

Radar #1(Test A) DFS detection threshold level and the burst of pulses on the Channel frequency

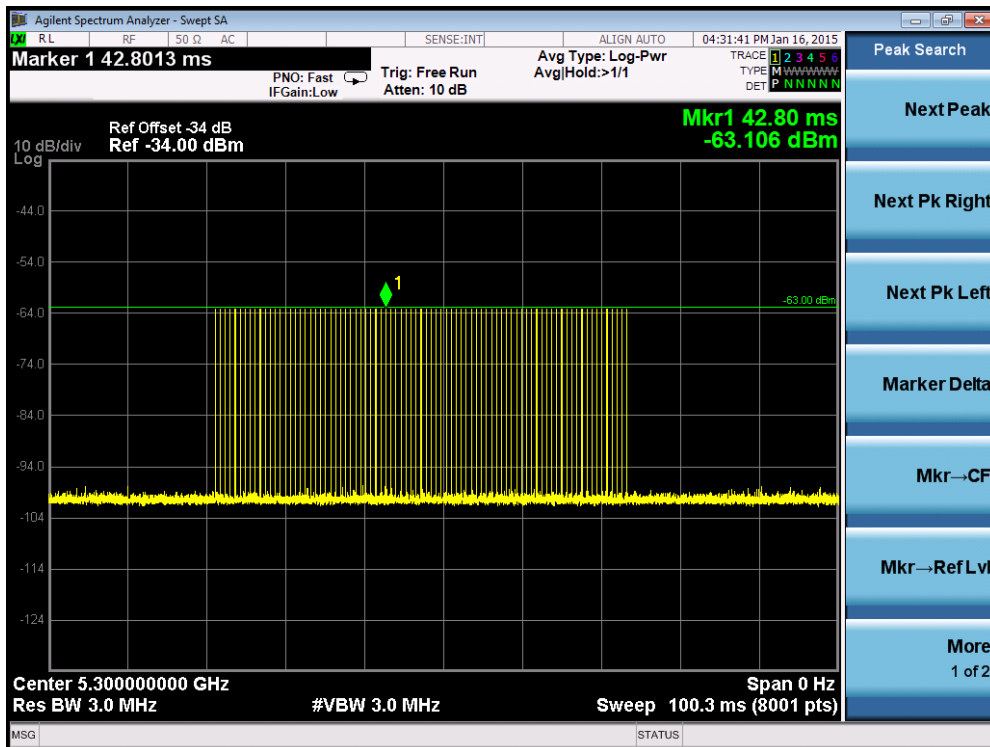

PRI = 598us and the number of pulses = 89

Radar #1(Test B) DFS detection threshold level and the burst of pulses on the Channel frequency

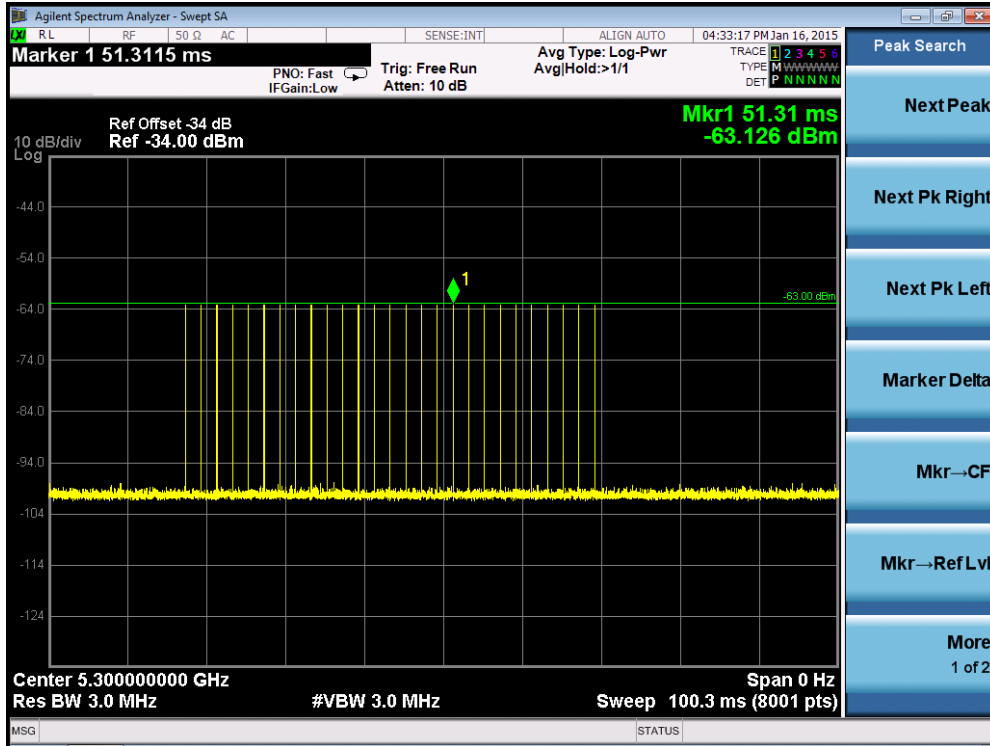

PRI = 2.003ms and the number of pulses = 27

Radar #2 DFS detection threshold level and the burst of pulses on the Channel frequency

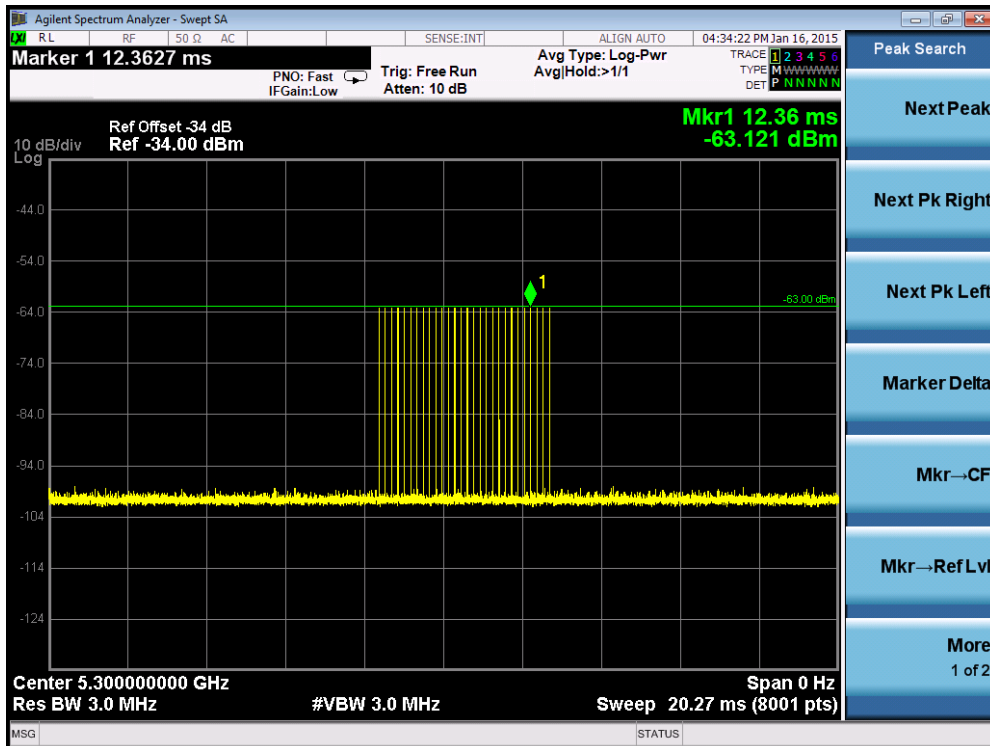

Radar #3 DFS detection threshold level and the burst of pulses on the Channel frequency

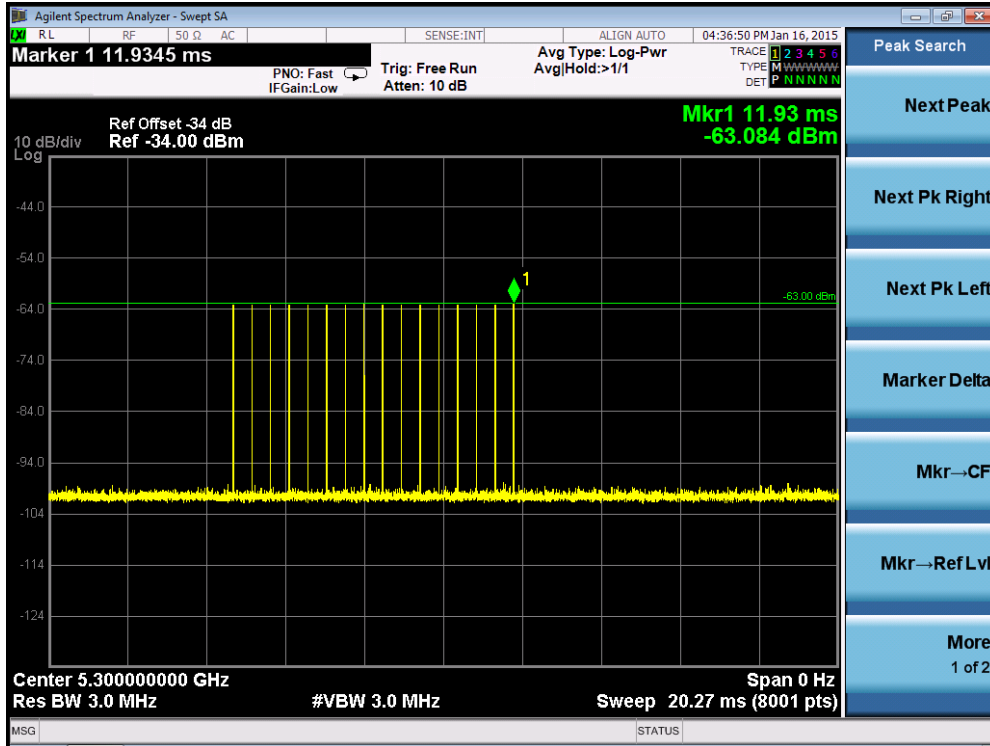

Radar #4 DFS detection threshold level and the burst of pulses on the Channel frequency

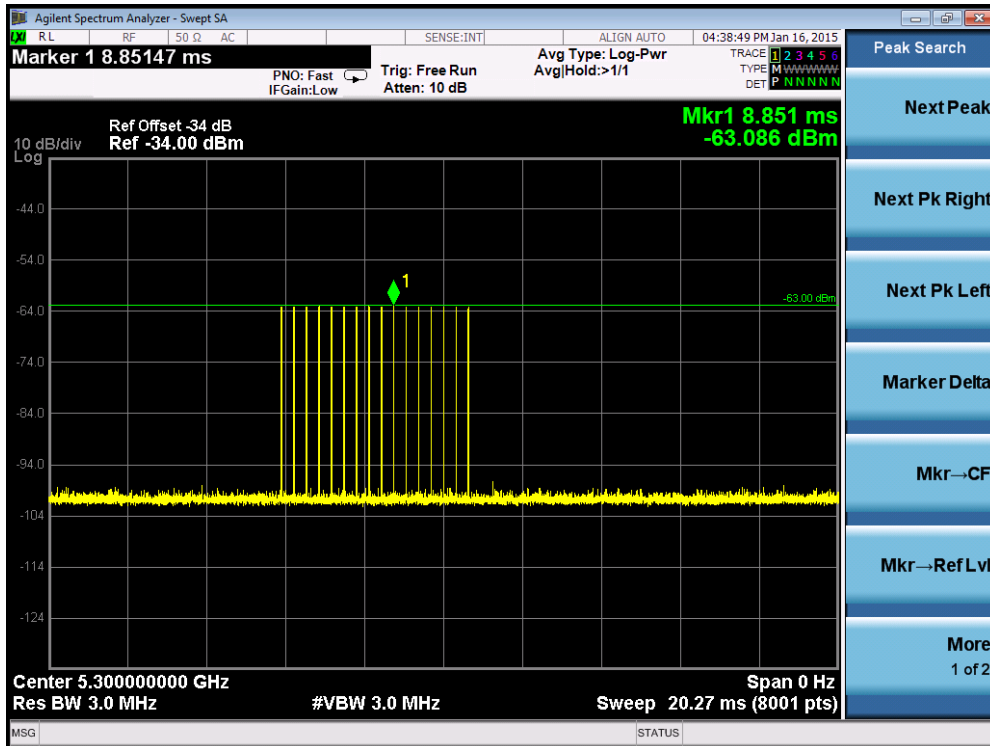

Radar #5 DFS detection threshold level and 12sec long burst on the Channel frequency

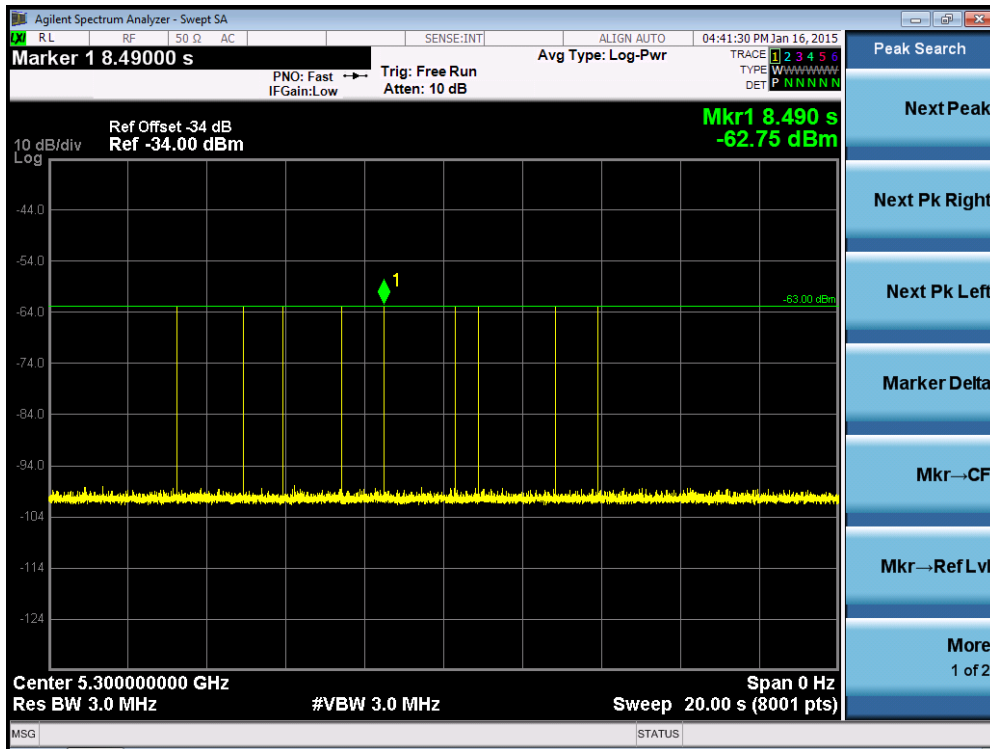

Radar #6 DFS detection threshold level and a single hop (9 pulses) on the Channel frequency within UNII detection bandwidth

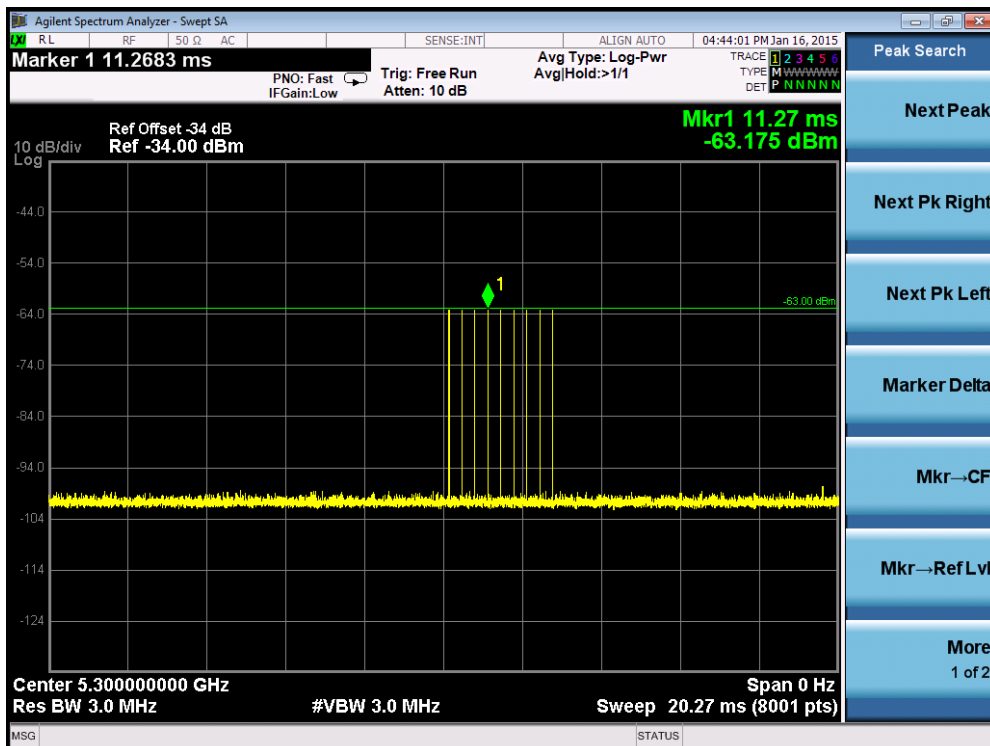

5.3. Channel Loading Test Result

System testing was performed with the designated MPEG test file that streams full motion video from the WiFi Concurrent 4 Port GE LAN VoIP Ethernet Gateway with USB to the Client in full motion video mode using the media player with the V2.61 Codec package. This file is used by IP and Frame based systems for loading the test channel during the In-service compliance testing of the U-NII device. Packet ratio = Time On/ (Time On + Off Time).

Channel Loading Plot - 802.11a-5300MHz

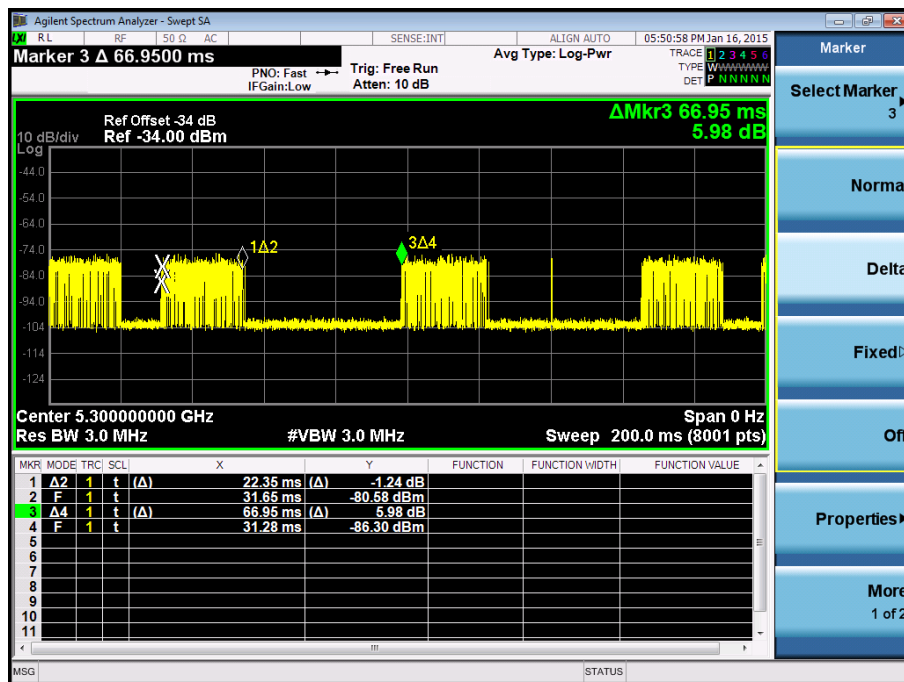

Channel Loading Plot - 802.11n-HT40 5310MHz

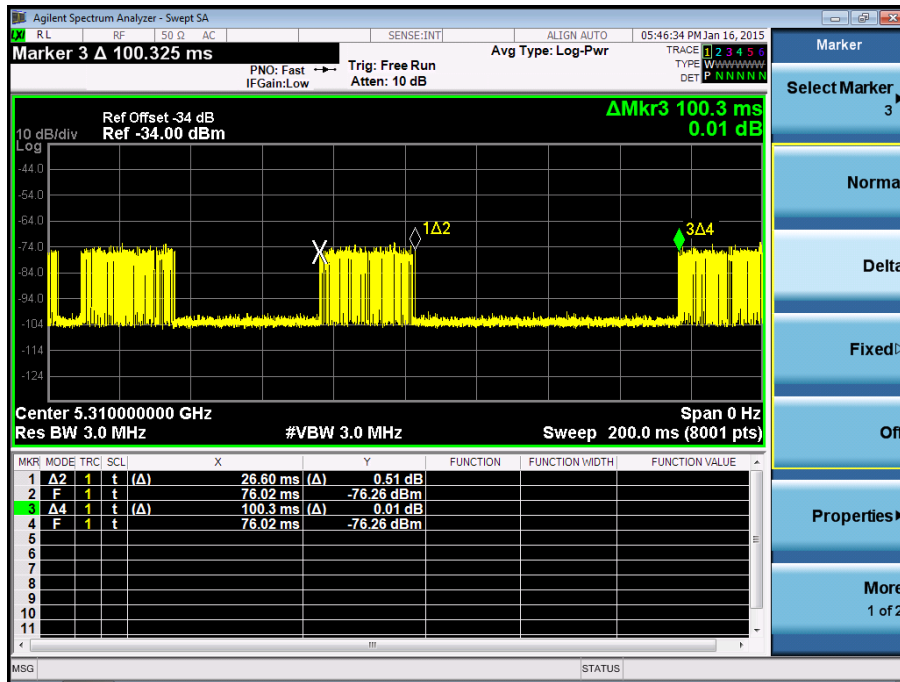

Channel Loading Plot - 802.11ac80 5290MHz

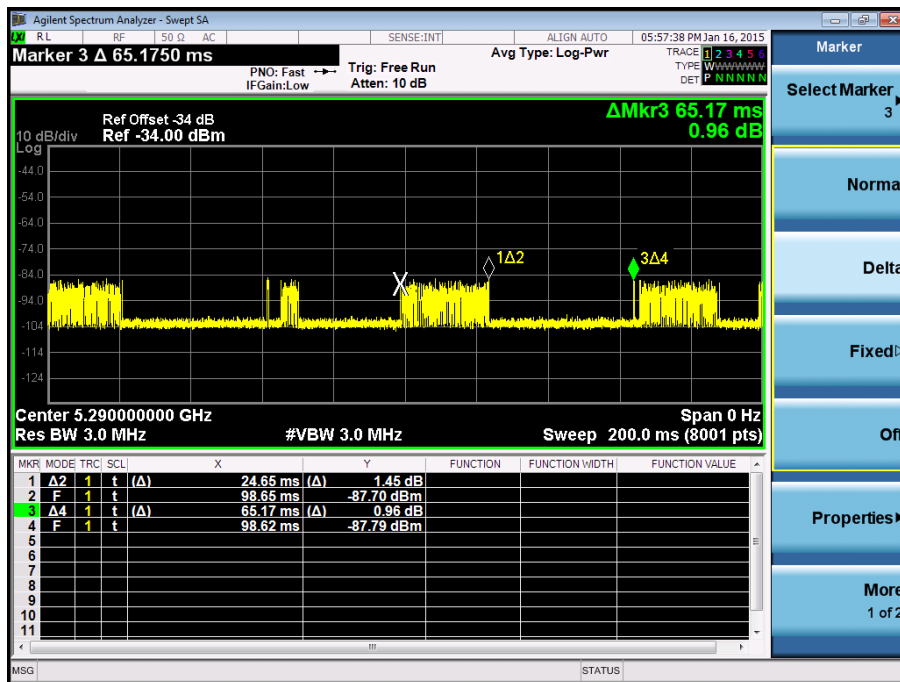

Test Mode	Packet ratio	Requirement ratio	Test Result
802.11a	33.38%	>17%	Pass
802.11n-40MHz	26.52%	>17%	Pass
802.11ac-80MHz	37.82%	>17%	Pass

5.4. UNII Detection Bandwidth Measurement

5.4.1. Test Limit

Minimum 100% of the UNII 99% transmission power bandwidth. During the U-NII Detection Bandwidth detection test, each frequency step the minimum percentage of detection is 90 percent. Measurements are performed with no data traffic.

5.4.2. Test Procedure

1. Adjust the equipment to produce a single Burst of any one of the Short Pulse Radar Types 0-4 in Table 3-5 at the center frequency of the EUT Operating Channel at the specified DFS Detection Threshold level.
2. The generating equipment is configured as shown in the Conducted Test Setup above section 3.5.
3. The EUT is set up as a stand-alone device (no associated Client or Master, as appropriate) and no traffic. Frame based systems will be set to a talk/listen ratio reflecting the worst case (maximum) that is user configurable during this test.
4. Generate a single radar Burst, and note the response of the EUT. Repeat for a minimum of 10 trials. The EUT must detect the Radar Waveform using the specified U-NII Detection Bandwidth criterion shown in Table 3-5. In cases where the channel bandwidth may exceed past the DFS band edge on specific channels (i.e., 802.11ac or wideband frame based systems) select a channel that has the entire emission bandwidth within the DFS band. If this is not possible, test the detection BW to the DFS band edge.
5. Starting at the center frequency of the UUT operating Channel, increase the radar frequency in 5 MHz steps, repeating the above test sequence, until the detection rate falls below the U-NII Detection Bandwidth criterion specified in Table 3-3. Repeat this measurement in 1MHz steps at frequencies 5 MHz below where the detection rate begins to fall. Record the highest frequency (denote as FH) at which detection is greater than or equal to the U-NII Detection Bandwidth criterion. Recording the detection rate at frequencies above FH is not required to demonstrate compliance.
6. Starting at the center frequency of the EUT operating Channel, decrease the radar frequency in 1 MHz steps, repeating the above item 4 test sequence, until the detection rate falls below the U-NII Detection Bandwidth criterion. Record the lowest frequency (denote as FL) at which detection is greater than or equal to the U-NII Detection Bandwidth criterion. Recording the detection rate at frequencies below FL is not required to demonstrate compliance.
7. The U-NII Detection Bandwidth is calculated as follows: $U\text{-NII Detection Bandwidth} = FH - FL$
8. The U-NII Detection Bandwidth must be at least 100% of the EUT transmitter 99% power, otherwise, the EUT does not comply with DFS requirements.

5.4.3. Test Result

EUT Frequency=5300MHz for 802.11a											
Radar Frequency (MHz)	DFS Detection Trials (1=Detection, 0= No Detection)										Detection Rate (%)
	1	2	3	4	5	6	7	8	9	10	
5285	0	0	0	0	0	0	0	0	0	0	0%
5286	0	0	0	0	0	0	0	0	0	0	0%
5287	0	0	0	0	0	0	0	0	0	0	0%
5288	0	0	0	0	0	0	0	0	0	0	0%
5289	0	0	0	0	0	0	0	0	0	0	0%
5290 FL	1	1	1	1	1	1	1	1	1	1	100%
5291	1	1	1	1	1	1	1	1	1	1	100%
5292	1	1	1	1	1	1	1	1	1	1	100%
5293	1	1	1	1	1	1	1	1	1	1	100%
5294	1	1	1	1	1	1	1	1	1	1	100%
5295	1	1	1	1	1	1	1	1	1	1	100%
5296	1	1	1	1	1	1	1	1	1	1	100%
5297	1	1	1	1	1	1	1	1	1	1	100%
5298	1	1	1	1	1	1	1	1	1	1	100%
5299	1	1	1	1	1	1	1	1	1	1	100%
5300	1	1	1	1	1	1	1	1	1	1	100%
5301	1	1	1	1	1	1	1	1	1	1	100%
5302	1	1	1	1	1	1	1	1	1	1	100%
5303	1	1	1	1	1	1	1	1	1	1	100%
5304	1	1	1	1	1	1	1	1	1	1	100%
5305	1	1	1	1	1	1	1	1	1	1	100%
5306	1	1	1	1	1	1	1	1	1	1	100%
5307	1	1	1	1	1	1	1	1	1	1	100%
5308	1	1	1	1	1	1	1	1	1	1	100%
5309	1	1	1	1	1	1	1	1	1	1	100%
5310 FH	1	1	1	1	1	1	1	1	1	1	100%
5311	0	0	0	0	0	0	0	0	0	0	0%
5312	0	0	0	0	0	0	0	0	0	0	0%
5313	0	0	0	0	0	0	0	0	0	0	0%

5314	0	0	0	0	0	0	0	0	0	0	0%
5315	0	0	0	0	0	0	0	0	0	0	0%
Detection Bandwidth = FH - FL = 5310MHz - 5290MHz = 20MHz											
EUT 99% Bandwidth = 16.96MHz (see note)											
UNII Detection Bandwidth Min. Limit (MHz): 16.96MHz x 100% = 16.96MHz											

Note: All UNII channels for this device have identical Channel bandwidths. Therefore, all DFS testing was done at 5300MHz. The 99% channel bandwidth is 17.03MHz. (See the 99% BW section of the RF report for further measurement details).

EUT Frequency=5310MHz for 802.11n-HT40											
Radar Frequency (MHz)	DFS Detection Trials (1=Detection, 0= No Detection)										Detection Rate (%)
	1	2	3	4	5	6	7	8	9	10	
5290	0	0	0	0	0	0	0	0	0	0	0%
5291	0	0	0	0	0	0	0	0	0	0	0%
5292 FL	1	1	1	1	1	1	1	1	1	1	100%
5293	1	1	1	1	1	1	1	1	1	1	100%
5294	1	1	1	1	1	1	1	1	1	1	100%
5295	1	1	1	1	1	1	1	1	1	1	100%
5296	1	1	1	1	1	1	1	1	1	1	100%
5297	1	1	1	1	1	1	1	1	1	1	100%
5298	1	1	1	1	1	1	1	1	1	1	100%
5299	1	1	1	1	1	1	1	1	1	1	100%
5300	1	1	1	1	1	1	1	1	1	1	100%
5301	1	1	1	1	1	1	1	1	1	1	100%
5302	1	1	1	1	1	1	1	1	1	1	100%
5303	1	1	1	1	1	1	1	1	1	1	100%
5304	1	1	1	1	1	1	1	1	1	1	100%
5305	1	1	1	1	1	1	1	1	1	1	100%
5306	1	1	1	1	1	1	1	1	1	1	100%
5307	1	1	1	1	1	1	1	1	1	1	100%
5308	1	1	1	1	1	1	1	1	1	1	100%
5309	1	1	1	1	1	1	1	1	1	1	100%
5310	1	1	1	1	1	1	1	1	1	1	100%
5311	1	1	1	1	1	1	1	1	1	1	100%
5312	1	1	1	1	1	1	1	1	1	1	100%
5313	1	1	1	1	1	1	1	1	1	1	100%
5314	1	1	1	1	1	1	1	1	1	1	100%
5315	1	1	1	1	1	1	1	1	1	1	100%
5316	1	1	1	1	1	1	1	1	1	1	100%
5317	1	1	1	1	1	1	1	1	1	1	100%
5318	1	1	1	1	1	1	1	1	1	1	100%
5319	1	1	1	1	1	1	1	1	1	1	100%

5320	1	1	1	1	1	1	1	1	1	1	100%
5321	1	1	1	1	1	1	1	1	1	1	100%
5322	1	1	1	1	1	1	1	1	1	1	100%
5323	1	1	1	1	1	1	1	1	1	1	100%
5324	1	1	1	1	1	1	1	1	1	1	100%
5325	1	1	1	1	1	1	1	1	1	1	100%
5326	1	1	1	1	1	1	1	1	1	1	100%
5327	1	1	1	1	1	1	1	1	1	1	100%
5328	1	1	1	1	1	1	1	1	1	1	100%
5329 FH	1	1	1	1	1	1	1	1	1	1	100%
5330	1	1	1	1	1	1	1	1	1	1	100%
Detection Bandwidth = FH - FL = 5330MHz - 5292MHz = 38MHz											
EUT 99% Bandwidth = 36.49MHz (see note)											
UNII Detection Bandwidth Min. Limit (MHz): 36.53MHz x 100% = 36.49MHz											

Note: All UNII channels for this device have identical Channel bandwidths. Therefore, all DFS testing was done at 5310MHz. The 99% channel bandwidth is 36.53MHz. (See the 99% BW section of the RF report for further measurement details).

EUT Frequency=5290MHz for 802.11ac-VHT80											
Radar Frequency (MHz)	DFS Detection Trials (1=Detection, 0= No Detection)										Detection Rate (%)
	1	2	3	4	5	6	7	8	9	10	
5245	0	0	0	0	0	0	0	0	0	0	0%
5246	0	0	0	0	0	0	0	0	0	0	0%
5247	0	0	0	0	0	0	0	0	0	0	0%
5248	0	0	0	0	0	0	0	0	0	0	0%
5249	0	0	0	0	0	0	0	0	0	0	0%
5250 FL	1	1	1	1	1	1	1	1	1	1	100%
5251	1	1	1	1	1	1	1	1	1	1	100%
5252	1	1	1	1	1	1	1	1	1	1	100%
5253	1	1	1	1	1	1	1	1	1	1	100%
5254	1	1	1	1	1	1	1	1	1	1	100%
5255	1	1	1	1	1	1	1	1	1	1	100%
5256	1	1	1	1	1	1	1	1	1	1	100%
5257	1	1	1	1	1	1	1	1	1	1	100%
5258	1	1	1	1	1	1	1	1	1	1	100%
5259	1	1	1	1	1	1	1	1	1	1	100%
5260	1	1	1	1	1	1	1	1	1	1	100%
5261	1	1	1	1	1	1	1	1	1	1	100%
5262	1	1	1	1	1	1	1	1	1	1	100%
5263	1	1	1	1	1	1	1	1	1	1	100%
5264	1	1	1	1	1	1	1	1	1	1	100%
5265	1	1	1	1	1	1	1	1	1	1	100%
5266	1	1	1	1	1	1	1	1	1	1	100%
5267	1	1	1	1	1	1	1	1	1	1	100%
5268	1	1	1	1	1	1	1	1	1	1	100%
5269	1	1	1	1	1	1	1	1	1	1	100%
5270	1	1	1	1	1	1	1	1	1	1	100%
5271	1	1	1	1	1	1	1	1	1	1	100%
5272	1	1	1	1	1	1	1	1	1	1	100%
5273	1	1	1	1	1	1	1	1	1	1	100%

5274	1	1	1	1	1	1	1	1	1	1	100%
5275	1	1	1	1	1	1	1	1	1	1	100%
5276	1	1	1	1	1	1	1	1	1	1	100%
5277	1	1	1	1	1	1	1	1	1	1	100%
5278	1	1	1	1	1	1	1	1	1	1	100%
5279	1	1	1	1	1	1	1	1	1	1	100%
5280	1	1	1	1	1	1	1	1	1	1	100%
5281	1	1	1	1	1	1	1	1	1	1	100%
5282	1	1	1	1	1	1	1	1	1	1	100%
5283	1	1	1	1	1	1	1	1	1	1	100%
5284	1	1	1	1	1	1	1	1	1	1	100%
5285	1	1	1	1	1	1	1	1	1	1	100%
5286	1	1	1	1	1	1	1	1	1	1	100%
5287	1	1	1	1	1	1	1	1	1	1	100%
5288	1	1	1	1	1	1	1	1	1	1	100%
5289	1	1	1	1	1	1	1	1	1	1	100%
5290	1	1	1	1	1	1	1	1	1	1	100%
5291	1	1	1	1	1	1	1	1	1	1	100%
5292	1	1	1	1	1	1	1	1	1	1	100%
5293	1	1	1	1	1	1	1	1	1	1	100%
5294	1	1	1	1	1	1	1	1	1	1	100%
5295	1	1	1	1	1	1	1	1	1	1	100%
5296	1	1	1	1	1	1	1	1	1	1	100%
5297	1	1	1	1	1	1	1	1	1	1	100%
5298	1	1	1	1	1	1	1	1	1	1	100%
5299	1	1	1	1	1	1	1	1	1	1	100%
5300	1	1	1	1	1	1	1	1	1	1	100%
5301	1	1	1	1	1	1	1	1	1	1	100%
5302	1	1	1	1	1	1	1	1	1	1	100%
5303	1	1	1	1	1	1	1	1	1	1	100%
5304	1	1	1	1	1	1	1	1	1	1	100%
5305	1	1	1	1	1	1	1	1	1	1	100%
5306	1	1	1	1	1	1	1	1	1	1	100%

5307	1	1	1	1	1	1	1	1	1	1	100%
5308	1	1	1	1	1	1	1	1	1	1	100%
5309	1	1	1	1	1	1	1	1	1	1	100%
5310	1	1	1	1	1	1	1	1	1	1	100%
5311	1	1	1	1	1	1	1	1	1	1	100%
5312	1	1	1	1	1	1	1	1	1	1	100%
5313	1	1	1	1	1	1	1	1	1	1	100%
5314	1	1	1	1	1	1	1	1	1	1	100%
5315	1	1	1	1	1	1	1	1	1	1	100%
5316	1	1	1	1	1	1	1	1	1	1	100%
5317	1	1	1	1	1	1	1	1	1	1	100%
5318	1	1	1	1	1	1	1	1	1	1	100%
5319	1	1	1	1	1	1	1	1	1	1	100%
5320	1	1	1	1	1	1	1	1	1	1	100%
5321	1	1	1	1	1	1	1	1	1	1	100%
5322	1	1	1	1	1	1	1	1	1	1	100%
5323	1	1	1	1	1	1	1	1	1	1	100%
5324	1	1	1	1	1	1	1	1	1	1	100%
5325	1	1	1	1	1	1	1	1	1	1	100%
5326	1	1	1	1	1	1	1	1	1	1	100%
5327	1	1	1	1	1	1	1	1	1	1	100%
5328	1	1	1	1	1	1	1	1	1	1	100%
5329	1	1	1	1	1	1	1	1	1	1	100%
5330 FH	1	1	1	1	1	1	1	1	1	1	100%
5331	0	0	0	0	0	0	0	0	0	0	0%
5332	0	0	0	0	0	0	0	0	0	0	0%
5334	0	0	0	0	0	0	0	0	0	0	0%
5335	0	0	0	0	0	0	0	0	0	0	0%
5336	0	0	0	0	0	0	0	0	0	0	0%
Detection Bandwidth = FH - FL = 5330MHz - 5250MHz = 80MHz											
EUT 99% Bandwidth = 75.55MHz (see note)											
UNII Detection Bandwidth Min. Limit (MHz): 76.00MHz x 100% = 75.55MHz											

Note: All UNII channels for this device have identical Channel bandwidths. Therefore, all DFS testing was done at 5290MHz. The 99% channel bandwidth is 76.00MHz. (See the 99% BW section of the RF report for further

measurement details).

5.5. Initial Channel Availability Check Time Measurement

5.5.1. Test Limit

The EUT shall perform a Channel Availability Check to ensure that there is no radar operating on the channel. After power-up sequence, receive at least 1 minute on the intended operating frequency.

5.5.2. Test Procedure

1. The U-NII devices will be powered on and be instructed to operate on the appropriate U-NII Channel that must incorporate DFS functions. At the same time the EUT is powered on, the spectrum analyzer will be set to zero span mode with a 3 MHz RBW and 3 MHz VBW on the Channel occupied by the radar (Chr) with a 2.5 minute sweep time. The spectrum analyzer's sweep will be started at the same time power is applied to the U-NII device.
2. The EUT should not transmit any beacon or data transmissions until at least 1 minute after the completion of the power-on cycle.
3. Confirm that the EUT initiates transmission on the channel. Measurement system showing its nominal noise floor is marker1.

5.5.3. Test Result

The EUT does not transmit any beacon or data transmissions until at least 1 minute after the completion of the power-on cycle (120.9 sec). Initial beacons/data transmissions are indicated by marker 1 (180.9 sec).

Initial Channel Availability Check Time for 802.11a

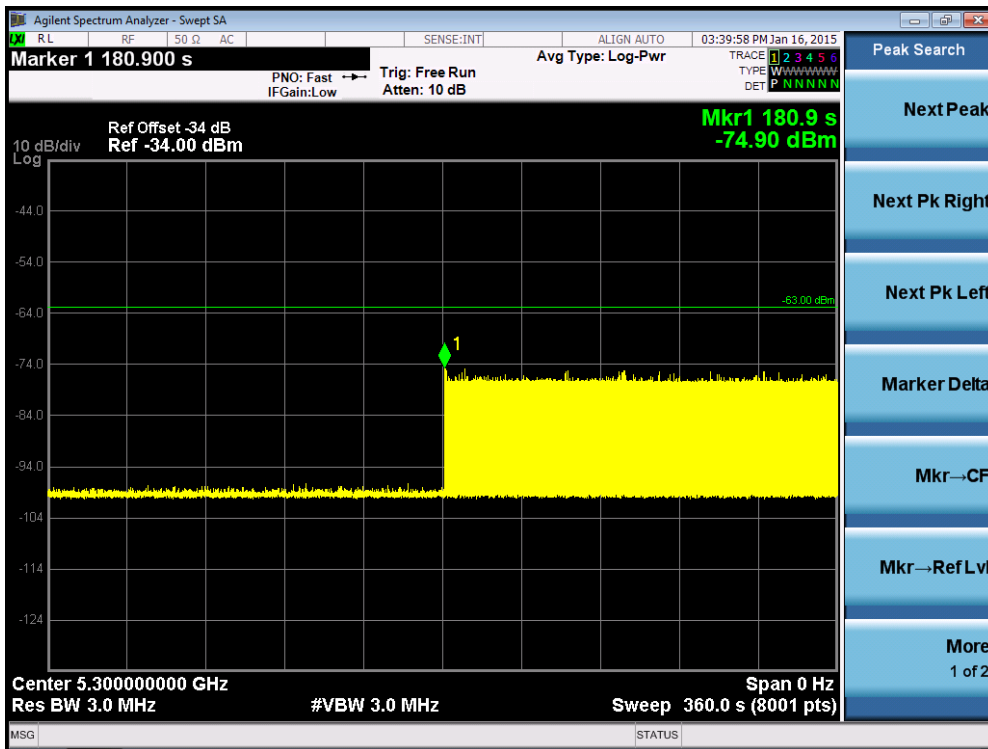

5.6. Radar Burst at the Beginning of the Channel Availability Check Time Measurement

5.6.1. Test Limit

In beginning of the Channel Availability Check (CAC) Time, radar is detected on this channel, select another intended channel and perform a CAC on that channel.

5.6.2. Test Procedure

1. The steps below define the procedure to verify successful radar detection on the selected Channel during a period equal to the Channel Availability Check Time and avoidance of operation on that Channel when a radar Burst with a level equal to the DFS Detection Threshold + 1 dB occurs at the beginning of the Channel Availability Check Time.
2. The EUT is in completion power-up cycle (from T0 to T1). T1 denotes the instant when the EUT has completed its power-up sequence. The Channel Availability Check Time commences at instant T1 and will end no sooner than T1 + 60 seconds. A single Burst of one of Short Pulse Radar Types 0-4 at DFS Detection Threshold + 1 dB will commence within a 6 second window starting at T1.
3. Visual indication on the EUT of successful detection of the radar Burst will be recorded and reported. Observation of emissions at 5300MHz (for 802.11a) will continue for 2.5 minutes after the radar Burst has been generated. Verify that during the 2.5 minutes measurement window no EUT transmissions occurred at 5300MHz (for 802.11a).

5.6.3. Test Result

Radar Burst at the Beginning of the Channel Availability Check Time for 802.11a

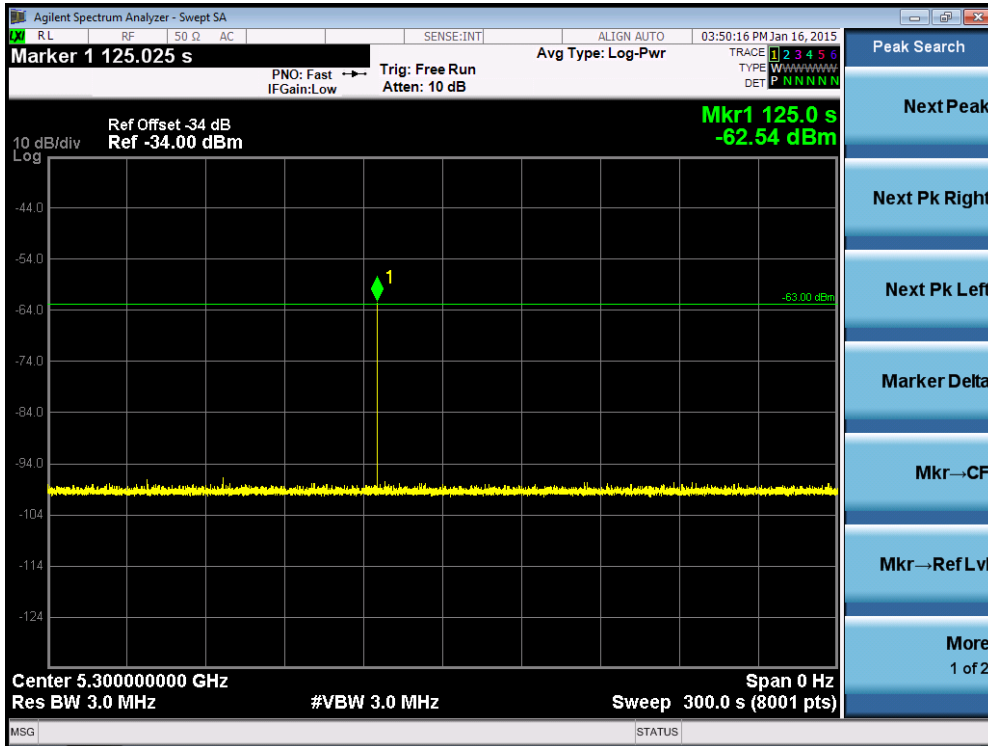

5.7. Radar Burst at the End of the Channel Availability Check Time Measurement

5.7.1. Test Limit

In the end of Channel Availability Check (CAC) Time, radar is detected on this channel, select another intended channel and perform a CAC on that channel.

5.7.2. Test Procedure

1. The steps below define the procedure to verify successful radar detection on the selected Channel during a period equal to the Channel Availability Check Time and avoidance of operation on that Channel when a radar Burst with a level equal to the DFS Detection Threshold + 1 dB occurs at the beginning of the Channel Availability Check Time.
2. The EUT is powered on at T0. T1 denotes the instant when the EUT has completed its power-up sequence. The Channel Availability Check Time commences at instant T1 and will end no sooner than T1 + 60 seconds. A single Burst of one of Short Pulse Radar Types 0-4 at DFS Detection Threshold + 1 dB will commence within a 6 second window starting at T1+ 54 seconds.
3. Visual indication on the EUT of successful detection of the radar Burst will be recorded and reported. Observation of emissions at 5300MHz (for 802.11a) will continue for 2.5 minutes after the radar Burst has been generated. Verify that during the 2.5 minutes measurement window no EUT transmissions occurred at 5300MHz (for 802.11a).

5.7.3. Test Result

Radar Burst at the End of the Channel Availability Check Time for 802.11a

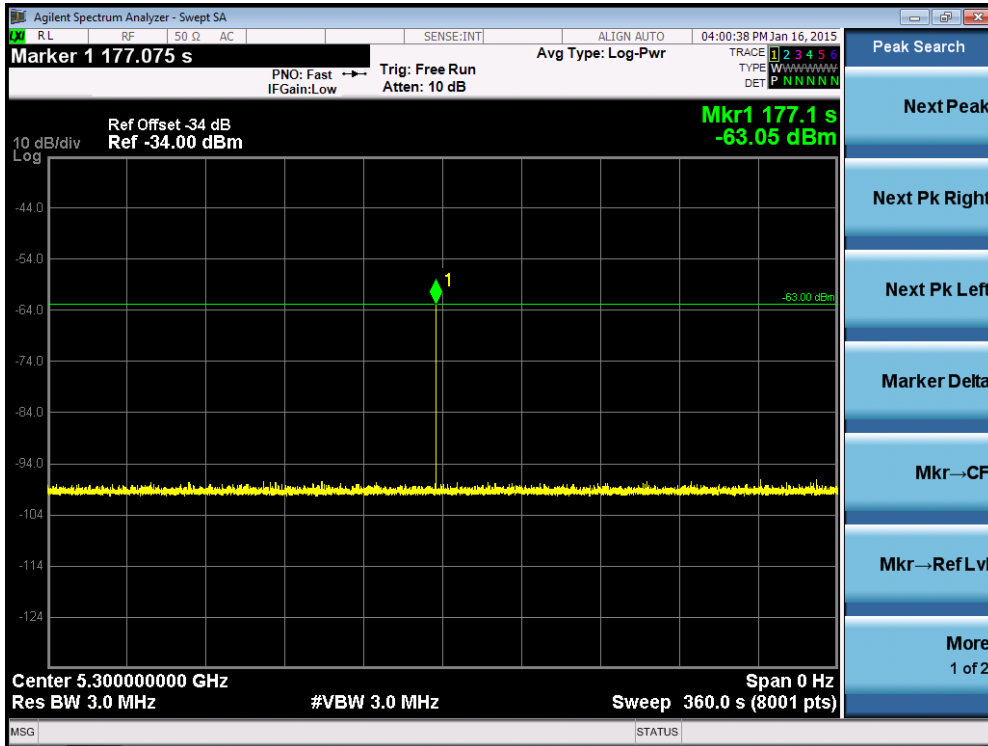

5.8. In-Service Monitoring for Channel Move Time, Channel Closing Transmission Time and Non-Occupancy Period Measurement

5.8.1. Test Limit

The EUT has In-Service Monitoring function to continuously monitor the radar signals. If the radar is detected, must leave the channel (Shutdown). The Channel Move Time to cease all transmissions on the current channel upon detection of a Radar Waveform above the DFS Detection Threshold within 10 sec. The total duration of Channel Closing Transmission Time is 260ms, consisting of data signals and the aggregate of control signals, by a U-NII device during the Channel Move Time. The Non-Occupancy Period time is 30 minute during which a Channel will not be utilized after a Radar Waveform is detected on that Channel.

5.8.2. Test Procedure Used

1. The test should be performed with Radar Type 0. The measurement timing begins at the end of the Radar Type 0.
2. When the radar burst with a level equal to the DFS Detection Threshold + 1dB is generated on the Operating Channel of the U-NII device. A U-NII device operating as a Master Device will associate with the Client Device at Channel. Stream the MPEG test file from the Master Device to the Client Device on the selected Channel for the entire period of the test. At time T0 the Radar Waveform generator sends a Burst of pulses for each of the radar types at Detection Threshold + 1dB.
2. Observe the transmissions of the EUT at the end of the radar Burst on the Operating Channel. Measure and record the transmissions from the EUT during the observation time (Channel Move Time).
3. Measurement of the aggregate duration of the Channel Closing Transmission Time method. With the spectrum analyzer set to zero span tuned to the center frequency of the EUT operating channel at the radar simulated frequency, peak detection, and max hold, the dwell time per bin is given by: $Dwell (1.5ms) = S (12 \text{ sec}) / B (8000)$; where Dwell is the dwell time per spectrum analyzer sampling bin, S is the sweep time and B is the number of spectrum analyzer sampling bins. An upper bound of the aggregate duration of the intermittent control signals of Channel Closing Transmission Time is calculated by: $80\text{MHz}: C (0 \text{ ms}) = N (0) \times Dwell (1.5 \text{ ms})$; where C is the Closing Time, N is the number of spectrum analyzer sampling bins showing a U-NII transmission and Dwell is the dwell time per bin.
4. Measure the EUT for more than 30 minutes following the channel close/move time to verify that the EUT does not resume any transmissions on this Channel.

5.8.3. Test Result

Channel Move Time and Channel Closing Transmission Time for 802.11ac-VHT80

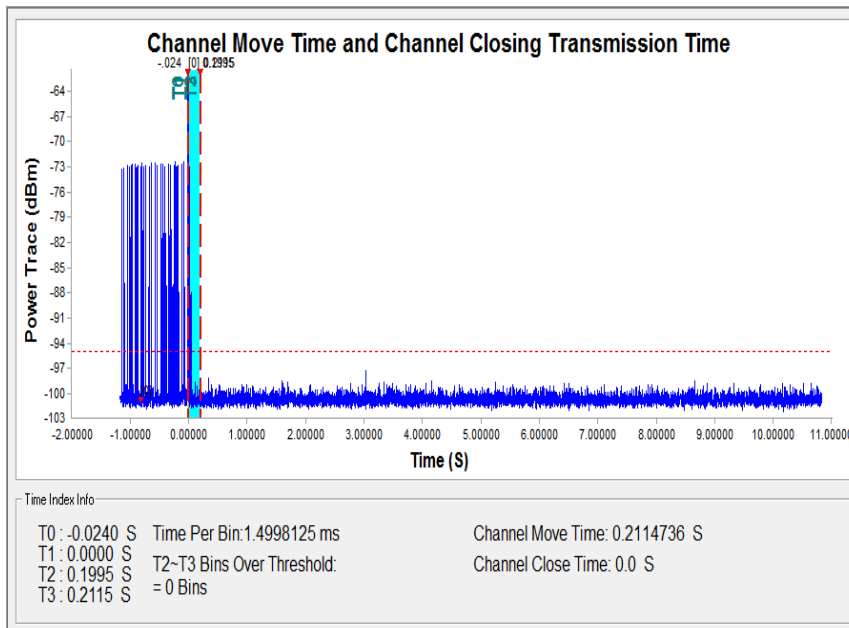
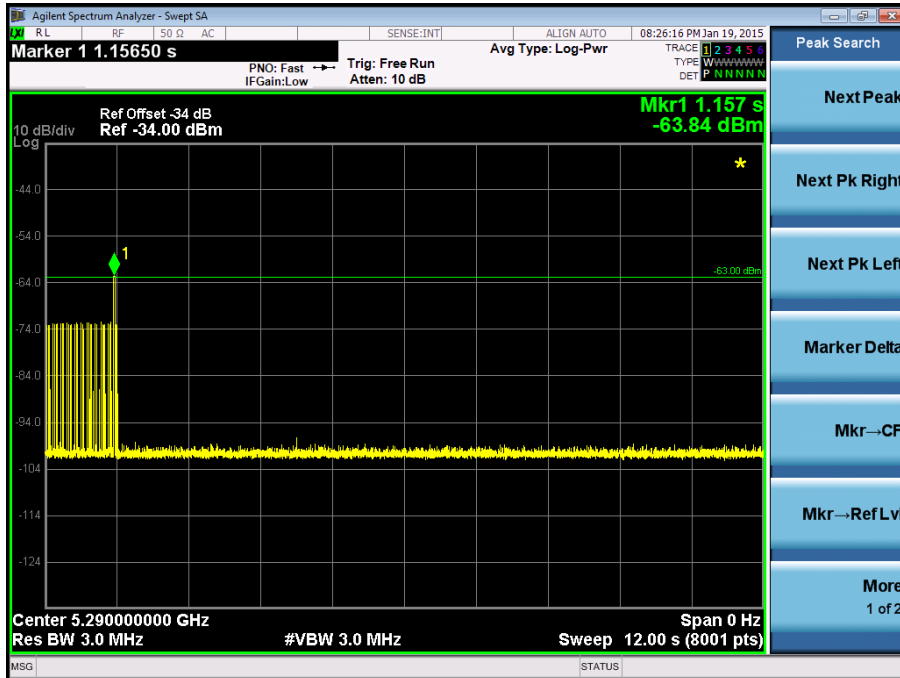

Non-Occupancy Period for 802.11a

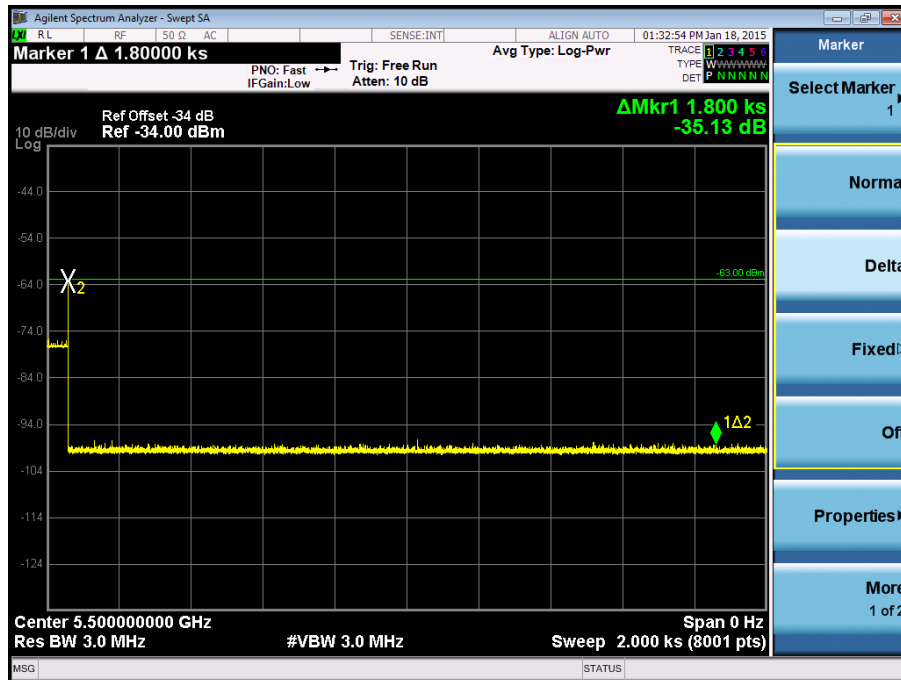

Parameter	Test Result	Limit
	Type 0	
Channel Move Time (s)	0.211s	<10s
Channel Closing Transmission Time (ms) (Note)	0ms	< 60ms
Non-Occupancy Period (min)	≥ 30min	≥ 30 min

Note: The Channel Closing Transmission Time is comprised of 200 milliseconds starting at the beginning of the Channel Move Time plus any additional intermittent control signals required to facilitate a Channel move (an aggregate of 60 milliseconds) during the remainder of the 10 seconds period. The aggregate duration of control signals will not count quiet periods in between transmissions.

5.9. Statistical Performance Check Measurement

5.9.1. Test Limit

The minimum percentage of successful detection requirements found in below table when a radar burst with a level equal to the DFS Detection Threshold + 1dB is generated on the Operating Channel of the U-NII device (In- Service Monitoring).

Radar Type	Minimum Number of Trails	Detection Probability
0	30	Pd > 60%
1	30(15 of test A and 15 of test B)	Pd > 60%
2	30	Pd > 60%
3	30	Pd > 60%
4	30	Pd > 60%
Aggregate (Radar Types 1-4)	120	Pd > 80%
5	30	Pd > 80%
6	30	Pd > 70%

The percentage of successful detection is calculated by:

$(\text{Total Waveform Detections} / \text{Total Waveform Trails}) * 100 = \text{Probability of Detection Radar Waveform}$

In addition an aggregate minimum percentage of successful detection across all Short Pulse Radar Types 1-4 is required and is calculated as follows: $(Pd1 + Pd2 + Pd3 + Pd4) / 4$.

5.9.2. Test Procedure

1. Stream the MPEG test file from the Master Device to the Client Device on the test Channel for the entire period of the test.
2. At time T0 the Radar Waveform generator sends the individual waveform for each of the Radar Types 1-6, at levels equal to the DFS Detection Threshold + 1dB, on the Operating Channel.
3. Observe the transmissions of the EUT at the end of the Burst on the Operating Channel for duration greater than 10 seconds for Short Pulse Radar Types 0 to ensure detection occurs.
4. Observe the transmissions of the EUT at the end of the Burst on the Operating Channel for duration greater than 22 seconds for Long Pulse Radar Type 5 to ensure detection occurs.
5. The device can utilize a test mode to demonstrate when detection occurs to prevent the need to reset the device between trial runs.
6. The Minimum number of trails, minimum percentage of successful detection and the average

minimum percentage of successful detection are found in below table.

5.9.3. Test Result

Statistical Performance Check for 802.11a

Radar Type 1 - Radar Statistical Performance

Trail #	Test Freq. (MHz)	Pulse Width (us)	PRI (us)	Pulses / Burst	1=Detection 0=No Detection
1	5290	1	638	83	1
2	5290	1	858	62	1
3	5290	1	818	65	1
4	5290	1	678	78	1
5	5290	1	718	74	1
6	5290	1	758	70	1
7	5290	1	938	57	1
8	5290	1	618	86	1
9	5290	1	3066	18	1
10	5290	1	658	81	1
11	5290	1	598	89	1
12	5290	1	898	59	1
13	5290	1	698	76	1
14	5290	1	518	102	1
15	5290	1	578	92	1
16	5290	1	1254	43	1
17	5290	1	1792	30	1
18	5290	1	1263	42	1
19	5290	1	2085	26	1
20	5290	1	2603	21	1
21	5290	1	1465	37	1
22	5290	1	531	100	1
23	5290	1	1661	32	1
24	5290	1	1436	37	1
25	5290	1	2578	21	1
26	5290	1	2755	20	1
27	5290	1	1735	31	1
28	5290	1	1394	38	1
29	5290	1	2526	21	1
30	5290	1	1092	49	1

Detection Percentage (%)	100%
--------------------------	------

Radar Type 2 - Radar Statistical Performance

Trail #	Test Freq. (MHz)	Pulse Width (us)	PRI (us)	Pulses / Burst	1=Detection 0=No Detection
1	5300	1.6	225	24	1
2	5300	2.3	193	23	1
3	5300	3.0	157	24	1
4	5300	3.3	210	28	1
5	5300	4.2	165	28	1
6	5300	3.1	196	28	1
7	5300	3.4	219	26	1
8	5300	1.8	214	26	1
9	5300	2.1	224	28	1
10	5300	1.5	183	29	1
11	5300	3.2	198	23	1
12	5300	3.4	176	27	1
13	5300	2.3	174	28	1
14	5300	1.2	222	27	1
15	5300	2.8	197	28	1
16	5300	2.4	164	27	1
17	5300	3.0	222	25	1
18	5300	3.4	214	28	1
19	5300	2.1	201	29	1
20	5300	1.1	164	23	1
21	5300	4.1	211	27	1
22	5300	1.9	191	27	1
23	5300	1.4	164	25	1
24	5300	1.7	203	23	1
25	5300	1.8	157	23	1
26	5300	4.4	175	24	1
27	5300	2.8	218	29	1
28	5300	2.4	167	23	0
29	5300	3.9	174	23	1
30	5300	2.2	226	23	1
Detection Percentage (%)					96.7%

Radar Type 3 - Radar Statistical Performance

Trail #	Test Freq. (MHz)	Pulse Width (us)	PRI (us)	Pulses / Burst	1=Detection 0=No Detection
1	5310	6.0	309	16	1
2	5310	8.4	443	16	1
3	5310	6.2	346	16	1
4	5310	9.8	304	17	1
5	5310	7.0	272	18	1
6	5310	9.8	310	16	1
7	5310	7.6	494	17	1
8	5310	7.8	451	16	1
9	5310	9.0	319	18	1
10	5310	6.2	389	18	1
11	5310	9.0	281	16	1
12	5310	8.1	296	18	1
13	5310	8.5	460	16	1
14	5310	7.5	416	16	0
15	5310	8.2	440	18	1
16	5310	7.8	274	18	1
17	5310	6.0	436	16	1
18	5310	6.3	448	18	1
19	5310	8.5	275	18	1
20	5310	8.9	376	18	1
21	5310	9.2	381	16	1
22	5310	9.5	361	18	1
23	5310	9.5	265	18	1
24	5310	6.0	303	18	1
25	5310	10.0	396	18	1
26	5310	6.4	465	17	1
27	5310	7.1	363	16	1
28	5310	8.9	423	16	1
29	5310	7.6	457	17	0
30	5310	9.4	306	17	1
Detection Percentage (%)					96.7%

Radar Type 4 - Radar Statistical Performance

Trail #	Test Freq. (MHz)	Pulse Width (us)	PRI (us)	Pulses / Burst	1=Detection 0=No Detection
1	5310	13.5	383	15	1
2	5310	11.5	331	16	1
3	5310	11.6	328	13	1
4	5310	15.5	268	14	1
5	5310	13.9	290	13	1
6	5310	15.5	430	13	1
7	5310	18.9	327	15	1
8	5310	18.8	401	15	1
9	5310	17.5	456	14	1
10	5310	15.1	310	14	1
11	5310	17.8	329	14	1
12	5310	16.2	292	14	1
13	5310	17.7	382	15	1
14	5310	17.6	386	16	1
15	5310	16.9	251	15	1
16	5310	16.6	404	12	1
17	5310	15.2	367	15	1
18	5310	12.0	424	12	1
19	5310	15.8	422	13	1
20	5310	13.6	439	12	1
21	5310	12.9	392	15	1
22	5310	17.4	396	16	1
23	5310	13.3	355	12	1
24	5310	15.9	326	14	1
25	5310	16.7	448	13	1
26	5310	19.2	291	14	1
27	5310	16.0	287	16	1
28	5310	12.7	265	16	1
29	5310	13.7	379	15	1
30	5310	15.5	480	13	1
Detection Percentage (%)					100%

Note: In addition an average minimum percentage of successful detection across all four Short pulse radar test

waveforms is as follows: $\frac{P_d1+P_d2+P_d3+P_d4}{4} = (100\%+96.7\%+96.7\%+100\%)/4 = 98.35\% (>80\%)$



Radar Type 5 - Radar Statistical Performance

Trail #	Test Freq. (MHz)	1=Detection 0=No Detection	Trail #	Test Freq. (MHz)	1=Detection 0=No Detection
1	5310	1	16	5310	1
2	5310	1	17	5310	1
3	5310	1	18	5310	1
4	5310	1	19	5310	1
5	5310	1	20	5310	1
6	5310	1	21	5310	1
7	5310	1	22	5310	1
8	5310	1	23	5310	1
9	5310	1	24	5310	1
10	5310	1	25	5310	1
11	5310	1	26	5310	1
12	5310	1	27	5310	1
13	5310	1	28	5310	1
14	5310	1	29	5310	1
15	5310	1	30	5310	1
Detection Percentage (%)					100%

Type 5 Radar Waveform_1										
Waveform Num = 1										
Num of Bursts = 10										
Burst Interval (us)= 1200000										
Burst #	Off Time (us)	# Pulses	Chirp (MHz)	PW (us)	Pulse 1 Pri(us)	Pulse 2 Pri(us)	Pulse 3 Pri(us)	Start Loc (us)	Start Burst Interval(us)	End Burst Interval(us)
1	517359	1	20	55	1155	0	0	517359	0	1199999
2	1316094	1	11	80	1745	0	0	1834608	1200000	2399999
3	808680	1	12	65	1512	0	0	2645033	2400000	3599999
4	1572958	2	11	60	1699	1471	0	4219503	3600000	4799999
5	1601221	3	17	85	1158	1459	1826	5823894	4800000	5999999
6	808171	2	13	55	1738	1774	0	6636508	6000000	7199999
7	1068734	2	14	50	1655	1562	0	7708754	7200000	8399999
8	724522	1	18	75	1449	0	0	8436493	8400000	9599999
9	1619378	2	19	80	1453	1507	0	10057320	9600000	10799999
10	1177167	2	15	90	1186	1807	0	11237447	10800000	11999999
Total number of pulses in waveform = 17										



Type 5 Radar Waveform_2

Waveform Num = 2
 Num of Bursts = 20
 Burst Interval (us) = 600000

Burst #	Off Time (us)	# Pulses	Chirp (MHz)	PW (us)	Pulse 1 Pri (us)	Pulse 2 Pri (us)	Pulse 3 Pri (us)	Start Loc (us)	Start Burst Interval (us)	End Burst Interval (us)
1	529516	1	6	50	1456	0	0	529516	0	599999
2	145984	3	16	75	1277	1626	1385	676956	600000	1199999
3	690026	2	11	85	1510	1010	0	1371270	1200000	1799999
4	663836	1	6	95	1208	0	0	2037626	1800000	2399999
5	946075	2	14	50	1539	1822	0	2984908	2400000	2999999
6	156402	2	13	60	1616	1541	0	3144671	3000000	3599999
7	1014176	1	14	70	1504	0	0	4161904	3600000	4199999
8	358428	1	5	80	1253	0	0	4521836	4200000	4799999
9	462990	1	19	55	1871	0	0	4986079	4800000	5399999
10	507765	2	7	65	1728	1185	0	5495715	5400000	5999999
11	507118	3	16	70	1303	1552	1651	6005746	6000000	6599999
12	901089	2	12	65	1717	1380	0	6911341	6600000	7199999
13	717333	2	18	50	1758	1514	0	7631771	7200000	7799999
14	426640	1	15	100	1367	0	0	8061683	7800000	8399999
15	905136	1	13	55	1615	0	0	8968186	8400000	8999999
16	48065	3	6	85	1769	1972	1884	9014856	9000000	9599999
17	697314	2	13	90	1950	1533	0	9717795	9600000	10199999
18	992246	1	19	80	1707	0	0	10713524	10200000	10799999
19	506303	1	20	100	1312	0	0	11221534	10800000	11399999
20	304445	3	5	60	1883	1039	1760	11527291	11400000	11999999

Total number of pulses in waveform = 35

Type 5 Radar Waveform_3

Waveform Num = 3
 Num of Bursts = 9
 Burst Interval (us) = 1333333

Burst #	Off Time (us)	# Pulses	Chirp (MHz)	PW (us)	Pulse 1 Pri (us)	Pulse 2 Pri (us)	Pulse 3 Pri (us)	Start Loc (us)	Start Burst Interval (us)	End Burst Interval (us)
1	1240924	3	9	65	1762	1437	1961	1240924	0	1333332
2	992020	3	11	90	1574	1213	1557	2238104	1333333	2666665
3	547053	1	9	70	1208	0	0	2789501	2666666	3999998
4	2445860	2	10	100	1829	1228	0	5236569	3999999	5333331
5	410904	1	7	90	1774	0	0	5650530	5333332	6666664
6	2146300	3	5	80	1754	1910	1578	7798604	6666665	7999997
7	648693	1	7	95	1128	0	0	8452539	7999998	9333330
8	1046685	3	7	95	1183	1088	1389	9500352	9333331	10666663
9	1547122	3	14	80	1082	1243	1431	11051134	10666664	11999996

Total number of pulses in waveform = 20

Type 5 Radar Waveform_4

Waveform Num = 4
 Num of Bursts = 10
 Burst Interval (us) = 1200000

Burst #	Off Time (us)	# Pulses	Chirp (MHz)	PW (us)	Pulse 1 Pri (us)	Pulse 2 Pri (us)	Pulse 3 Pri (us)	Start Loc (us)	Start Burst Interval (us)	End Burst Interval (us)
1	89684	2	6	95	1009	1495	0	89684	0	1199999
2	2091046	2	14	80	1538	1641	0	2183234	1200000	2399999
3	834458	3	16	95	1895	1599	1234	3020871	2400000	3599999
4	1655875	3	14	85	1450	1570	1725	4681474	3600000	4799999
5	638463	3	7	80	1351	1381	1304	5324682	4800000	5999999
6	732371	2	9	85	1387	1839	0	6061089	6000000	7199999
7	1960438	2	10	90	1097	1814	0	8024753	7200000	8399999
8	1244580	1	17	65	1571	0	0	9272244	8400000	9599999
9	809341	3	14	55	1928	1468	1096	10083156	9600000	10799999
10	1521843	1	15	90	1804	0	0	11609491	10800000	11999999

Total number of pulses in waveform = 22



Type 5 Radar Waveform_5

Waveform Num = 5
Num of Bursts = 8
Burst Interval (us)= 1500000

Burst #	Off Time (us)	# Pulses	Chirp (MHz)	PW (us)	Pulse 1 Pri(us)	Pulse 2 Pri(us)	Pulse 3 Pri(us)	Start Loc (us)	Start Burst Interval (us)	End Burst Interval (us)
1	1236023	3	8	70	1851	1238	1861	1236023	0	1499999
2	1280532	3	15	80	1078	1038	1569	2521505	1500000	2999999
3	1143197	2	11	70	1226	1640	0	3668387	3000000	4499999
4	1864285	2	13	100	1365	1702	0	5535538	4500000	5999999
5	817138	3	6	85	1641	1010	1238	6355743	6000000	7499999
6	1405161	1	20	60	1584	0	0	7764793	7500000	8999999
7	1354050	3	6	75	1741	1722	1822	9120427	9000000	10499999
8	1715391	2	13	95	1962	1332	0	10841103	10500000	11999999

Total number of pulses in waveform = 19

Type 5 Radar Waveform_6

Waveform Num = 6
Num of Bursts = 17
Burst Interval (us)= 705882

Burst #	Off Time (us)	# Pulses	Chirp (MHz)	PW (us)	Pulse 1 Pri(us)	Pulse 2 Pri(us)	Pulse 3 Pri(us)	Start Loc (us)	Start Burst Interval (us)	End Burst Interval (us)
1	494757	2	10	100	1747	1795	0	494757	0	705881
2	452552	1	12	85	1957	0	0	950851	705882	1411763
3	966429	2	11	50	1126	1024	0	1919237	1411764	2117645
4	554201	2	8	75	1055	1395	0	2475588	2117646	2823527
5	980480	1	16	70	1932	0	0	3458518	2823528	3529409
6	176938	3	18	65	1952	1308	1534	3637388	3529410	4235291
7	1098267	3	18	75	1544	1923	1069	4740449	4235292	4941173
8	832427	3	12	85	1243	1358	1979	5577412	4941174	5647055
9	541966	3	17	75	1951	1846	1754	6123958	5647056	6352937
10	744250	2	13	90	1516	1384	0	6873759	6352938	7058819
11	400235	3	17	70	1100	1520	1545	7276894	7058820	7764701
12	1021568	2	5	90	1439	1652	0	8302627	7764702	8470583
13	233426	2	8	100	1202	1348	0	8539144	8470584	9176465
14	1013429	1	19	55	1181	0	0	9555123	9176466	9882347
15	783992	2	18	90	1205	1261	0	10340296	9882348	10588229
16	804251	2	18	65	1823	1290	0	11147013	10588230	11294111
17	314410	3	19	50	1718	1625	1606	11464536	11294112	11999993

Total number of pulses in waveform = 37

Type 5 Radar Waveform_7

Waveform Num = 7
Num of Bursts = 11
Burst Interval (us)= 1090909

Burst #	Off Time (us)	# Pulses	Chirp (MHz)	PW (us)	Pulse 1 Pri(us)	Pulse 2 Pri(us)	Pulse 3 Pri(us)	Start Loc (us)	Start Burst Interval (us)	End Burst Interval (us)
1	169936	2	15	60	1130	1999	0	169936	0	1090908
2	998522	1	5	50	1565	0	0	1171587	1090909	2181817
3	1079048	2	16	75	1997	1933	0	2252200	2181818	3272726
4	1223181	1	12	60	1961	0	0	3479311	3272727	4363635
5	1338288	1	19	90	1015	0	0	4819560	4363636	5454544
6	1284045	2	10	90	1479	1287	0	6104620	5454545	6545453
7	747785	3	20	85	1798	1159	1871	6855171	6545454	7636362
8	1581445	2	13	100	1033	1963	0	8441444	7636363	8727271
9	691667	2	11	85	1417	1094	0	9136107	8727272	9818180
10	730031	3	9	70	1946	1412	1583	9868649	9818181	10909089
11	2082176	3	20	55	1304	1601	1282	11955766	10909090	11999998

Total number of pulses in waveform = 22



Type 5 Radar Waveform_8

Waveform Num = 8
Num of Bursts = 14
Burst Interval (us) = 857143

Burst #	Off Time (us)	# Pulses	Chirp (MHz)	PW (us)	Pulse 1 Pri (us)	Pulse 2 Pri (us)	Pulse 3 Pri (us)	Start Loc (us)	Start Burst Interval (us)	End Burst Interval (us)
1	307402	1	16	90	1907	0	0	307402	0	857142
2	753389	3	12	60	1901	1223	1376	1062678	857143	1714285
3	951691	2	17	90	1008	1909	0	2018869	1714286	2571428
4	827736	1	17	65	1418	0	0	2849522	2571429	3428571
5	1360177	2	5	70	1399	1823	0	4211117	3428572	4285714
6	194859	3	12	75	1576	1776	1480	4409198	4285715	5142857
7	1474397	3	10	95	1302	1965	1878	5888427	5142858	6000000
8	251576	2	11	95	1122	1403	0	6145148	6000001	6857143
9	1045296	1	11	75	1417	0	0	7192969	6857144	7714286
10	855527	2	20	60	1154	1621	0	8049913	7714287	8571429
11	723031	2	6	95	1283	1850	0	8775719	8571430	9428572
12	1491725	1	11	65	1675	0	0	10270577	9428573	10285715
13	640727	1	15	95	1703	0	0	10912979	10285716	11142858
14	787033	3	16	55	1017	1024	1574	11701715	11142859	12000001

Total number of pulses in waveform = 27

Type 5 Radar Waveform_9

Waveform Num = 9
Num of Bursts = 19
Burst Interval (us) = 631579

Burst #	Off Time (us)	# Pulses	Chirp (MHz)	PW (us)	Pulse 1 Pri (us)	Pulse 2 Pri (us)	Pulse 3 Pri (us)	Start Loc (us)	Start Burst Interval (us)	End Burst Interval (us)
1	214522	3	15	50	1908	1177	1146	214522	0	631578
2	989245	1	13	55	1216	0	0	1207998	631579	1263157
3	676652	1	6	75	1462	0	0	1885866	1263158	1894736
4	66105	1	11	65	1388	0	0	1953433	1894737	2526315
5	988964	3	6	50	1509	1482	1281	2943785	2526316	3157894
6	604586	2	8	85	1331	1327	0	3552643	3157895	3789473
7	682907	2	9	95	1408	1676	0	4238208	3789474	4421052
8	619710	1	5	50	1984	0	0	4861002	4421053	5052631
9	465819	1	6	100	1603	0	0	5318805	5052632	5684210
10	811780	1	15	100	1342	0	0	6132188	5684211	6315789
11	577105	1	15	65	1026	0	0	6710635	6315790	6947368
12	339092	3	11	90	1061	1200	1815	7301592	6947369	7578947
13	653868	2	12	95	1241	1059	0	7644760	7578948	8210526
14	891913	3	11	60	1926	1491	1729	8300928	8210527	8842105
15	753051	3	5	80	1108	1375	1594	9197987	8842106	9473684
16	182374	3	10	85	1460	1774	1097	9955115	9473685	10105263
17	811939	2	19	100	1655	1874	0	10141820	10105264	10736842
18	635172	1	9	60	1353	0	0	10957288	10736843	11368421
19	635172	3	18	65	1920	1659	1775	11593813	11368422	12000000

Total number of pulses in waveform = 37

Type 5 Radar Waveform_10

Waveform Num = 10
Num of Bursts = 11
Burst Interval (us) = 1090909

Burst #	Off Time (us)	# Pulses	Chirp (MHz)	PW (us)	Pulse 1 Pri (us)	Pulse 2 Pri (us)	Pulse 3 Pri (us)	Start Loc (us)	Start Burst Interval (us)	End Burst Interval (us)
1	783229	1	12	75	1059	0	0	783229	0	1090908
2	1137166	1	20	95	1001	0	0	1921454	1090909	2181817
3	1120760	2	13	50	1338	1726	0	3043215	2181818	3272726
4	966781	1	6	100	1750	0	0	4013060	3272727	4363635
5	421035	1	8	65	1289	0	0	4435845	4363636	5454544
6	1591926	1	10	55	1720	0	0	6029060	5454545	6545453
7	586665	2	10	95	1461	1236	0	6617445	6545454	7636362
8	1606167	2	19	70	1281	1822	0	8226309	7636363	8727271
9	1376912	1	13	100	1182	0	0	9606324	8727272	9818180
10	639836	3	7	70	1616	1585	1015	10247342	9818181	10909089
11	841724	1	8	60	1465	0	0	11093282	10909090	11999998

Total number of pulses in waveform = 16



Type 5 Radar Waveform_11

Waveform Num = 11
Num of Bursts = 8
Burst Interval (us)= 1500000

Burst #	Off Time (us)	# Pulses	Chirp (MHz)	PW (us)	Pulse 1 Pri(us)	Pulse 2 Pri(us)	Pulse 3 Pri(us)	Start Loc (us)	Start Burst Interval(us)	End Burst Interval(us)
1	869080	2	14	85	1828	1412	0	869080	0	1499999
2	1788969	1	19	60	1745	0	0	2661289	1500000	2999999
3	1532375	2	8	55	1525	1007	0	4195409	3000000	4499999
4	323459	2	15	50	1890	1738	0	4521400	4500000	5999999
5	1542731	3	12	80	1564	1018	1132	6067759	6000000	7499999
6	2658442	2	18	65	1090	1958	0	8729915	7500000	8999999
7	397864	1	12	50	1949	0	0	9130827	9000000	10499999
8	1394493	3	17	55	1847	1957	1585	10527289	10500000	11999999

Total number of pulses in waveform = 16

Type 5 Radar Waveform_12

Waveform Num = 12
Num of Bursts = 11
Burst Interval (us)= 1090909

Burst #	Off Time (us)	# Pulses	Chirp (MHz)	PW (us)	Pulse 1 Pri(us)	Pulse 2 Pri(us)	Pulse 3 Pri(us)	Start Loc (us)	Start Burst Interval(us)	End Burst Interval(us)
1	636296	3	6	90	1050	1959	1236	636296	0	1090908
2	1410131	2	20	60	1997	1192	0	2050672	1090909	2181817
3	648749	3	15	65	1589	1190	1937	2702610	2181818	3272726
4	710572	1	20	55	1519	0	0	3417898	3272727	4363635
5	1557753	1	10	65	1320	0	0	4977170	4363636	5454544
6	1091032	3	9	80	1678	1681	1635	6069522	5454545	6545453
7	983654	1	13	90	1261	0	0	7058170	6545454	7636362
8	1524643	3	18	80	1641	1572	1373	8584074	7636363	8727271
9	383663	2	19	95	1119	1222	0	8972323	8727272	9818180
10	1523016	3	11	85	1125	1813	1001	10497680	9818181	10909089
11	1106554	2	16	80	1242	1833	0	11608173	10909090	11999998

Total number of pulses in waveform = 24

Type 5 Radar Waveform_13

Waveform Num = 13
Num of Bursts = 15
Burst Interval (us)= 800000

Burst #	Off Time (us)	# Pulses	Chirp (MHz)	PW (us)	Pulse 1 Pri(us)	Pulse 2 Pri(us)	Pulse 3 Pri(us)	Start Loc (us)	Start Burst Interval(us)	End Burst Interval(us)
1	660611	1	9	75	1030	0	0	660611	0	799999
2	348990	2	5	50	1289	1783	0	1010631	800000	1599999
3	1316081	2	6	65	1242	1224	0	2329784	1600000	2399999
4	815320	1	7	100	1911	0	0	3147570	2400000	3199999
5	183011	2	14	100	1202	1878	0	3332492	3200000	3999999
6	1112532	1	6	75	1589	0	0	4448104	4000000	4799999
7	397379	3	8	80	1773	1713	1088	4847072	4800000	5599999
8	1470410	3	18	70	1247	1965	1371	6322056	5600000	6399999
9	861486	3	20	65	1516	1162	1071	7188125	6400000	7199999
10	302825	3	15	65	1261	1134	1102	7494699	7200000	7999999
11	1118716	1	6	95	1291	0	0	8616912	8000000	8799999
12	371761	3	20	85	1036	1643	1821	8989964	8800000	9599999
13	681649	1	13	60	1046	0	0	9676113	9600000	10399999
14	1415937	3	16	95	1404	1255	1587	11093096	10400000	11199999
15	399094	2	8	60	1527	1075	0	11496436	11200000	11999999

Total number of pulses in waveform = 31



Type 5 Radar Waveform_14

Waveform Num = 14
Num of Bursts = 10
Burst Interval (us)= 1200000

Burst #	Off Time (us)	# Pulses	Chirp (MHz)	PW (us)	Pulse 1 Pri(us)	Pulse 2 Pri(us)	Pulse 3 Pri(us)	Start Loc (us)	Start Burst Interval(us)	End Burst Interval(us)
1	490307	2	11	80	1200	1903	0	490307	0	1199999
2	993949	2	7	70	1162	1884	0	1487359	1200000	2399999
3	1754811	2	15	85	1415	1823	0	3245216	2400000	3599999
4	771511	1	6	60	1276	0	0	4019965	3600000	4799999
5	827057	1	13	50	1886	0	0	4848298	4800000	5999999
6	1322637	3	10	90	1269	1484	1053	6172821	6000000	7199999
7	1907703	1	8	50	1130	0	0	8084330	7200000	8399999
8	1006347	1	16	65	1975	0	0	9091807	8400000	9599999
9	1577053	3	20	60	1932	1853	1323	10670835	9600000	10799999
10	299758	1	14	100	1491	0	0	10975701	10800000	11999999

Total number of pulses in waveform = 17

Type 5 Radar Waveform_15

Waveform Num = 15
Num of Bursts = 13
Burst Interval (us)= 923077

Burst #	Off Time (us)	# Pulses	Chirp (MHz)	PW (us)	Pulse 1 Pri(us)	Pulse 2 Pri(us)	Pulse 3 Pri(us)	Start Loc (us)	Start Burst Interval(us)	End Burst Interval(us)
1	284605	3	20	75	1475	1037	1758	284605	0	923076
2	1372935	3	18	65	1405	1689	1291	1661810	923077	1846153
3	730716	1	7	50	1179	0	0	2396911	1846154	2769230
4	936936	3	14	60	1212	1762	1339	3335026	2769231	3692307
5	1080934	3	19	65	1477	1666	1589	4420273	3692308	4615384
6	725088	3	7	95	1376	1445	1131	5150093	4615385	5538461
7	814586	1	11	85	1962	0	0	5968631	5538462	6461538
8	1113916	1	16	100	1393	0	0	7084509	6461539	7384615
9	337282	3	5	95	1800	1604	1557	7423130	7384616	8307692
10	1682978	1	14	90	1768	0	0	9110469	8307693	9230769
11	656199	2	16	55	1042	1694	0	9768436	9230770	10153846
12	536359	3	6	70	1331	1106	1886	10307531	10153847	11076923
13	1498834	2	15	15	1595	1694	0	11810688	11076924	12000000

Total number of pulses in waveform = 29

Type 5 Radar Waveform_16

Waveform Num = 16
Num of Bursts = 10
Burst Interval (us)= 1200000

Burst #	Off Time (us)	# Pulses	Chirp (MHz)	PW (us)	Pulse 1 Pri(us)	Pulse 2 Pri(us)	Pulse 3 Pri(us)	Start Loc (us)	Start Burst Interval(us)	End Burst Interval(us)
1	787758	2	10	50	1039	1394	0	787758	0	1199999
2	755930	1	15	90	1508	0	0	1546121	1200000	2399999
3	1796531	2	11	75	1932	1129	0	3344160	2400000	3599999
4	977831	1	5	95	1688	0	0	4325052	3600000	4799999
5	488065	3	6	50	1866	1746	1495	4814805	4800000	5999999
6	1488759	2	6	60	1633	1269	0	6308671	6000000	7199999
7	1183515	1	7	90	1532	0	0	7495088	7200000	8399999
8	1577568	1	10	70	1251	0	0	9074188	8400000	9599999
9	1117642	1	17	55	1016	0	0	10193081	9600000	10799999
10	1729907	2	6	85	1843	1997	0	11924004	10800000	11999999

Total number of pulses in waveform = 16



Type 5 Radar Waveform_17

Waveform Num = 17
Num of Bursts = 18
Burst Interval (us) = 666667

Burst #	Off Time (us)	# Pulses	Chirp (MHz)	PW (us)	Pulse 1 Pri (us)	Pulse 2 Pri (us)	Pulse 3 Pri (us)	Start Loc (us)	Start Burst Interval (us)	End Burst Interval (us)
1	638662	2	11	95	1505	1969	0	638662	0	666666
2	562557	2	8	65	1841	1303	0	1204693	666667	1333333
3	724272	3	17	80	1608	1620	1878	1932109	1333334	2000000
4	543061	2	14	80	1112	1732	0	2480276	2000001	2666667
5	555977	2	19	100	1512	1389	0	3039097	2666668	3333334
6	304914	2	6	55	1736	1874	0	3346912	3333335	4000001
7	1267148	1	18	100	1813	0	0	4617670	4000002	4666668
8	102696	2	15	65	1350	1701	0	4722179	4666669	5333335
9	834974	3	11	100	1208	1815	1555	5560204	5333336	6000002
10	936480	3	15	75	1376	1794	1794	6501262	6000003	6666669
11	644132	3	16	100	1991	1501	1773	7150264	6666670	7333336
12	292982	3	14	85	1636	1265	1939	7448511	7333337	8000003
13	820481	3	19	100	1352	1891	1554	8273832	8000004	8666670
14	1000774	1	17	75	1702	0	0	9279403	8666671	9333337
15	535148	1	14	65	1337	0	0	9816253	9333338	10000004
16	235535	2	11	50	1428	1970	0	10053125	10000005	10666671
17	909185	2	9	70	1150	1220	0	10965708	10666672	11333338
18	493512	3	19	85	1704	1066	1775	11461590	11333339	12000005

Total number of pulses in waveform = 40

Type 5 Radar Waveform_18

Waveform Num = 18
Num of Bursts = 17
Burst Interval (us) = 705882

Burst #	Off Time (us)	# Pulses	Chirp (MHz)	PW (us)	Pulse 1 Pri (us)	Pulse 2 Pri (us)	Pulse 3 Pri (us)	Start Loc (us)	Start Burst Interval (us)	End Burst Interval (us)
1	276475	3	10	60	1327	1178	1991	276475	0	705881
2	979068	3	19	55	1105	1314	1982	1280039	705882	1411763
3	173112	3	9	75	1174	1133	1514	1437552	1411764	2117645
4	1098786	1	15	90	1155	0	0	2540159	2117646	2823527
5	530252	1	17	60	1064	0	0	3071566	2823528	3529409
6	1062420	3	8	90	1743	1358	1487	4135050	3529410	4235291
7	144194	2	6	80	1722	1302	0	4283832	4235292	4941173
8	1342934	3	17	75	1434	1052	1541	5629790	4941174	5647055
9	520274	1	16	75	1273	0	0	6154091	5647056	6352937
10	643477	3	5	100	1481	1267	1567	6798841	6352938	7058819
11	842034	3	5	50	1008	1343	1179	7645190	7058820	7764701
12	792311	1	16	70	1214	0	0	8441031	7764702	8470583
13	160627	3	5	55	1385	1001	1592	8602872	8470584	9176465
14	1086281	1	17	80	1703	0	0	9693131	9176466	9882347
15	365337	2	13	65	1330	1699	0	10060171	9882348	10588229
16	750487	2	14	90	1336	1057	0	10813587	10588230	11294111
17	757300	2	17	65	1995	1370	0	11573280	11294112	11999993

Total number of pulses in waveform = 37

Type 5 Radar Waveform_19

Waveform Num = 19
Num of Bursts = 16
Burst Interval (us) = 750000

Burst #	Off Time (us)	# Pulses	Chirp (MHz)	PW (us)	Pulse 1 Pri (us)	Pulse 2 Pri (us)	Pulse 3 Pri (us)	Start Loc (us)	Start Burst Interval (us)	End Burst Interval (us)
1	500509	2	17	50	1863	1699	0	500509	0	749999
2	375936	3	8	85	1020	1264	1231	880007	750000	1499999
3	1156164	1	20	65	1233	0	0	2039686	1500000	2249999
4	668732	2	15	50	1554	1193	0	2709651	2250000	2999999
5	455795	1	16	70	1617	0	0	3168193	3000000	3749999
6	1103534	1	7	55	1725	0	0	4273344	3750000	4499999
7	712029	1	14	95	1952	0	0	4987098	4500000	5249999
8	603134	1	7	70	1247	0	0	5592184	5250000	5999999
9	767851	3	7	90	1971	1167	1638	6361282	6000000	6749999
10	501740	3	19	65	1756	1320	1974	6867798	6750000	7499999
11	678779	2	19	95	1396	1103	0	7551627	7500000	8249999
12	982310	3	15	55	1662	1383	1372	8536436	8250000	8999999
13	797786	1	15	55	1724	0	0	9338639	9000000	9749999
14	1023598	3	17	80	1931	1296	1220	10363961	9750000	10499999
15	370732	2	13	50	1667	1228	0	10739140	10500000	11249999
16	728111	3	5	85	1404	1320	1013	11470146	11250000	11999999

Total number of pulses in waveform = 32



Type 5 Radar Waveform_20

Waveform Num = 20
Num of Bursts = 12
Burst Interval (us)= 1000000

Burst #	Off Time (us)	# Pulses	Chirp (MHz)	PW (us)	Pulse 1 Pri (us)	Pulse 2 Pri (us)	Pulse 3 Pri (us)	Start Loc (us)	Start Burst Interval (us)	End Burst Interval (us)
1	818563	3	17	60	1096	1751	1696	818563	0	999999
2	434670	2	12	95	1324	1159	0	1257776	1000000	1999999
3	945517	2	11	70	1040	1657	0	2205776	2000000	2999999
4	1255226	1	20	70	1231	0	0	3463699	3000000	3999999
5	1093239	1	5	80	1809	0	0	4558169	4000000	4999999
6	765565	3	15	100	1718	1635	1234	5325543	5000000	5999999
7	949950	2	17	55	1982	1700	0	6280080	6000000	6999999
8	1607555	1	9	55	1036	0	0	7891317	7000000	7999999
9	508372	2	9	75	1890	1536	0	8400725	8000000	8999999
10	1221037	3	7	60	1063	1048	1147	9625188	9000000	9999999
11	757691	1	15	100	1795	0	0	10386137	10000000	10999999
12	794785	2	20	75	1728	1003	0	11182717	11000000	11999999

Total number of pulses in waveform = 23

Type 5 Radar Waveform_21

Waveform Num = 21
Num of Bursts = 19
Burst Interval (us)= 631579

Burst #	Off Time (us)	# Pulses	Chirp (MHz)	PW (us)	Pulse 1 Pri (us)	Pulse 2 Pri (us)	Pulse 3 Pri (us)	Start Loc (us)	Start Burst Interval (us)	End Burst Interval (us)
1	290772	1	13	50	1687	0	0	290772	0	631578
2	726384	2	11	65	1891	1313	0	1018843	631579	1263157
3	726828	3	13	85	1203	1472	1215	1748875	1263158	1894736
4	316670	2	11	90	1285	1892	0	2069435	1894737	2526315
5	498250	3	7	60	1434	1899	1766	2570862	2526316	3157894
6	731116	2	20	100	1188	1032	0	3307077	3157895	3789473
7	877412	3	5	70	1582	1326	1312	4186709	3789474	4421052
8	330997	1	8	55	1752	0	0	4521926	4421053	5052631
9	833301	2	5	75	1037	1072	0	5356979	5052632	5684210
10	376765	2	8	95	1645	1123	0	5735853	5684211	6315789
11	1122309	2	9	50	1477	1307	0	6860930	6315790	6947368
12	708879	3	12	100	1286	1889	1471	7572593	6947369	7578947
13	348389	1	17	75	1062	0	0	7925628	7578948	8210526
14	753494	3	20	50	1884	1009	1122	8680184	8210527	8842105
15	548465	2	12	75	1401	1535	0	9232664	8842106	9473684
16	804321	1	19	70	1095	0	0	10039921	9473685	10105263
17	668920	1	13	65	1822	0	0	10709936	10105264	10736842
18	618749	1	20	85	1857	0	0	11330507	10736843	11368421
19	653944	1	16	55	1366	0	0	11986308	11368422	12000000

Total number of pulses in waveform = 36

Type 5 Radar Waveform_22

Waveform Num = 22
Num of Bursts = 19
Burst Interval (us)= 631579

Burst #	Off Time (us)	# Pulses	Chirp (MHz)	PW (us)	Pulse 1 Pri (us)	Pulse 2 Pri (us)	Pulse 3 Pri (us)	Start Loc (us)	Start Burst Interval (us)	End Burst Interval (us)
1	273824	2	17	60	1177	1705	0	273824	0	631578
2	905950	1	5	75	1401	0	0	1182656	631579	1263157
3	248352	3	14	70	1144	1347	1935	1432409	1263158	1894736
4	690870	3	8	100	1313	1516	1467	2127705	1894737	2526315
5	553358	1	15	50	1069	0	0	2685359	2526316	3157894
6	521154	2	9	80	1920	1296	0	3207582	3157895	3789473
7	1086268	2	20	75	1501	1030	0	4297066	3789474	4421052
8	315438	1	11	80	1335	0	0	4615035	4421053	5052631
9	785543	1	12	55	1075	0	0	5401913	5052632	5684210
10	377366	2	19	90	1535	1257	0	5780354	5684211	6315789
11	892515	1	20	65	1270	0	0	6675661	6315790	6947368
12	735278	1	5	80	1223	0	0	7412209	6947369	7578947
13	238784	1	17	55	1210	0	0	7652216	7578948	8210526
14	614036	3	19	95	1491	1920	1752	8267462	8210527	8842105
15	663043	1	7	100	1962	0	0	8935668	8842106	9473684
16	895653	3	14	70	1925	1135	1307	9833283	9473685	10105263
17	746472	3	11	75	1237	1298	1083	10584122	10105264	10736842
18	226208	3	18	95	1405	1320	1249	10813948	10736843	11368421
19	1010440	2	17	65	1066	1768	0	11828362	11368422	12000000

Total number of pulses in waveform = 36



Type 5 Radar Waveform_23

Waveform Num = 23
Num of Bursts = 18
Burst Interval (us)= 66667

Burst #	Off Time (us)	# Pulses	Chirp (MHz)	PW (us)	Pulse 1 Pri (us)	Pulse 2 Pri (us)	Pulse 3 Pri (us)	Start Loc (us)	Start Burst Interval (us)	End Burst Interval (us)
1	402592	3	13	85	1534	1650	1487	402592	0	666666
2	890088	3	9	80	1525	1708	1783	1084263	666667	1333333
3	620813	1	10	75	1740	0	0	1969367	1333334	2000000
4	485766	1	14	100	1287	0	0	2591920	2000001	2666667
5	486772	2	20	85	1399	1246	0	3078973	2666668	3333334
6	1061684	3	6	50	1994	1883	1325	3568390	3333335	4000001
7	285425	1	11	60	1347	0	0	4635276	4000002	4666668
8	730478	3	18	90	1392	1301	1985	4922048	4666669	5333335
9	603840	3	6	60	1080	1431	1075	5657204	5333336	6000002
10	701397	3	15	75	1882	1818	1854	6264630	6000003	6666669
11	875229	1	5	90	1357	0	0	6971521	6666670	7333336
12	653392	1	10	85	1370	0	0	7848107	7333337	8000003
13	621800	2	18	85	1902	1167	0	8502869	8000004	8666670
14	219697	1	14	100	1820	0	0	9127738	8666671	9333337
15	677196	3	15	100	1980	1785	1925	9349195	9333338	10000004
16	1128895	2	19	90	1143	1778	0	10032081	10000005	10666671
17	821048	2	17	100	1352	1410	0	11163897	10666672	11333338
18		2	20	95	1453	1282	0	11987707	11333339	12000005

Total number of pulses in waveform = 37

Type 5 Radar Waveform_24

Waveform Num = 24
Num of Bursts = 10
Burst Interval (us)= 1200000

Burst #	Off Time (us)	# Pulses	Chirp (MHz)	PW (us)	Pulse 1 Pri (us)	Pulse 2 Pri (us)	Pulse 3 Pri (us)	Start Loc (us)	Start Burst Interval (us)	End Burst Interval (us)
1	622560	2	12	65	1957	1907	0	622560	0	1199999
2	1645081	3	15	75	1441	1040	1228	2271505	1200000	2399999
3	420372	2	18	90	1509	1363	0	2695586	2400000	3599999
4	1780524	1	17	60	1883	0	0	4478982	3600000	4799999
5	1425423	1	5	50	1876	0	0	5906288	4800000	5999999
6	1283688	2	14	75	1941	1424	0	7191852	6000000	7199999
7	1141483	1	9	80	1094	0	0	8336700	7200000	8399999
8	998182	3	8	75	1205	1716	1921	9335976	8400000	9599999
9	1092378	3	14	65	1449	1061	1720	10433196	9600000	10799999
10	440806	2	10	95	1375	1501	0	10878232	10800000	11999999

Total number of pulses in waveform = 20

Type 5 Radar Waveform_25

Waveform Num = 25
Num of Bursts = 13
Burst Interval (us)= 923077

Burst #	Off Time (us)	# Pulses	Chirp (MHz)	PW (us)	Pulse 1 Pri (us)	Pulse 2 Pri (us)	Pulse 3 Pri (us)	Start Loc (us)	Start Burst Interval (us)	End Burst Interval (us)
1	814629	1	9	75	1671	0	0	814629	0	923076
2	262998	2	20	55	1626	1065	0	1079298	923077	1846153
3	1656663	3	15	80	1821	1122	1948	2738652	1846154	2769230
4	764401	2	6	80	1444	1055	0	3507944	2769231	3692307
5	242010	1	12	100	1411	0	0	3752453	3692308	4615384
6	1264895	2	10	85	1499	1293	0	5018759	4615385	5538461
7	585290	2	16	60	1230	1904	0	5606841	5538462	6461538
8	1226287	3	12	70	1858	1374	1476	6836262	6461539	7384615
9	1346515	2	6	60	1907	1996	0	8187485	7384616	8307692
10	438001	3	17	50	1595	1878	1762	8629389	8307693	9230769
11	879513	2	5	85	1079	1444	0	9514137	9230770	10153846
12	692975	1	10	80	1074	0	0	10209635	10153847	11076923
13	1080817	2	12	70	1513	1108	0	11291526	11076924	12000000

Total number of pulses in waveform = 26



Type 5 Radar Waveform_26

Waveform Num = 26
Num of Bursts = 10
Burst Interval (us)= 1200000

Burst #	Off Time (us)	# Pulses	Chirp (MHz)	PW (us)	Pulse 1 Pri (us)	Pulse 2 Pri (us)	Pulse 3 Pri (us)	Start Loc (us)	Start Burst Interval (us)	End Burst Interval (us)
1	1003727	2	19	95	1151	1019	0	1003727	0	1199999
2	1121704	3	14	65	1203	1096	1790	2127601	1200000	2399999
3	368959	1	8	90	1405	0	0	2500649	2400000	3599999
4	1901195	2	9	80	1911	1012	0	4403249	3600000	4799999
5	1475702	3	14	95	1904	1389	1349	5881874	4800000	5999999
6	722395	3	9	85	1371	1387	1221	6608911	6000000	7199999
7	1775362	3	14	95	1794	1404	1624	8388252	7200000	8399999
8	389583	1	7	70	1616	0	0	8782657	8400000	9599999
9	1797844	1	6	95	1575	0	0	10582117	9600000	10799999
10	548718	3	15	50	1024	1237	1734	11132410	10800000	11999999

Total number of pulses in waveform = 22

Type 5 Radar Waveform_27

Waveform Num = 27
Num of Bursts = 12
Burst Interval (us)= 1000000

Burst #	Off Time (us)	# Pulses	Chirp (MHz)	PW (us)	Pulse 1 Pri (us)	Pulse 2 Pri (us)	Pulse 3 Pri (us)	Start Loc (us)	Start Burst Interval (us)	End Burst Interval (us)
1	662374	3	11	85	1820	1346	1422	662374	0	999999
2	637828	1	15	55	1619	0	0	1304790	1000000	1999999
3	1358997	3	19	70	1237	1577	1034	2665406	2000000	2999999
4	1136139	2	6	80	1355	1823	0	3805393	3000000	3999999
5	468977	3	5	60	1512	1927	1648	4277548	4000000	4999999
6	1239443	3	12	90	1986	1047	1728	5522078	5000000	5999999
7	905245	1	10	55	1436	0	0	6432084	6000000	6999999
8	1147340	3	12	100	1503	1819	1185	7580860	7000000	7999999
9	1250905	2	20	100	1113	1847	0	8836272	8000000	8999999
10	1031795	2	7	50	1546	1672	0	9871027	9000000	9999999
11	713625	1	9	95	1052	0	0	10587870	10000000	10999999
12	1064954	3	12	65	1863	1938	1746	11653876	11000000	11999999

Total number of pulses in waveform = 27

Type 5 Radar Waveform_28

Waveform Num = 28
Num of Bursts = 17
Burst Interval (us)= 705882

Burst #	Off Time (us)	# Pulses	Chirp (MHz)	PW (us)	Pulse 1 Pri (us)	Pulse 2 Pri (us)	Pulse 3 Pri (us)	Start Loc (us)	Start Burst Interval (us)	End Burst Interval (us)
1	123393	3	9	55	1120	1681	1460	123393	0	705881
2	813661	2	17	60	1886	1440	0	941315	705882	1411763
3	789785	1	14	65	1977	0	0	1734426	1411764	2117645
4	897447	1	16	80	1492	0	0	2633850	2117646	2823527
5	461168	3	13	65	1676	1312	1990	3096510	2823528	3529409
6	555673	1	17	80	1890	0	0	3657161	3529410	4235291
7	1148595	2	10	90	1999	1482	0	4807646	4235292	4941173
8	710490	2	6	80	1378	1223	0	5521617	4941174	5647055
9	449444	1	20	90	1400	0	0	5973662	5647056	6352937
10	728005	1	6	95	1590	0	0	6703067	6352938	7058819
11	752617	2	10	90	1225	1496	0	7457274	7058820	7764701
12	335650	2	16	70	1749	1443	0	7795645	7764702	8470583
13	1235537	2	11	95	1750	1628	0	9034374	8470584	9176465
14	564873	2	13	65	1307	1804	0	9602625	9176466	9882347
15	334829	2	9	55	1917	1789	0	9940565	9882348	10588229
16	1160366	1	20	75	1234	0	0	11104637	10588230	11294111
17	874125	2	19	50	1518	1624	0	11979996	11294112	11999993

Total number of pulses in waveform = 30



Type 5 Radar Waveform_29

Waveform Num = 29
Num of Bursts = 12
Burst Interval (us)= 1000000

Burst #	Off Time (us)	# Pulses	Chirp (MHz)	PW (us)	Pulse 1 Pri (us)	Pulse 2 Pri (us)	Pulse 3 Pri (us)	Start Loc (us)	Start Burst Interval (us)	End Burst Interval (us)
1	843507	2	16	95	1588	1593	0	843507	0	999999
2	819710	2	19	65	1620	1219	0	1666398	1000000	1999999
3	1036151	1	13	80	1258	0	0	2705388	2000000	2999999
4	539922	3	20	55	1762	1596	1451	3246568	3000000	3999999
5	755488	2	20	65	1209	1216	0	4006865	4000000	4999999
6	1846987	2	11	75	1603	1298	0	5856277	5000000	5999999
7	760775	3	11	100	1482	1190	1466	6619953	6000000	6999999
8	1019506	2	17	80	1607	1899	0	7643597	7000000	7999999
9	1207005	2	20	50	1939	1764	0	8854108	8000000	8999999
10	1106936	1	12	70	1492	0	0	9964747	9000000	9999999
11	155727	1	10	55	1040	0	0	10121966	10000000	10999999
12	943990	2	11	65	1923	1251	0	11066996	11000000	11999999

Total number of pulses in waveform = 23

Type 5 Radar Waveform_30

Waveform Num = 30
Num of Bursts = 9
Burst Interval (us)= 1333333

Burst #	Off Time (us)	# Pulses	Chirp (MHz)	PW (us)	Pulse 1 Pri (us)	Pulse 2 Pri (us)	Pulse 3 Pri (us)	Start Loc (us)	Start Burst Interval (us)	End Burst Interval (us)
1	679871	2	13	50	1558	1277	0	679871	0	1333332
2	1250635	3	9	65	1869	1674	1206	1933341	1333333	2666665
3	1091084	1	6	90	1823	0	0	3029174	2666666	3999998
4	1641340	1	13	55	1413	0	0	4672337	3999999	5333331
5	1657929	1	13	80	1106	0	0	6331679	5333332	6666664
6	783727	1	7	65	1137	0	0	7116512	6666665	7999997
7	1553094	3	20	75	1442	1152	1490	8670743	7999998	9333330
8	1019944	1	12	50	1356	0	0	9694771	9333331	10666663
9	1513742	3	9	100	1917	1968	1075	11209869	10666664	11999996

Total number of pulses in waveform = 16

Radar Type 6 - Radar Statistical Performance

Trail #	Test Freq. (MHz)	1=Detection 0=No Detection	Trail #	Test Freq. (MHz)	1=Detection 0=No Detection
1	5300	1	16	5300	1
2	5300	1	17	5300	1
3	5300	1	18	5300	1
4	5300	1	19	5300	1
5	5300	1	20	5300	1
6	5300	1	21	5300	1
7	5300	1	22	5300	1
8	5300	1	23	5300	1
9	5300	1	24	5300	1
10	5300	1	25	5300	1
11	5300	1	26	5300	1
12	5300	1	27	5300	1
13	5300	1	28	5300	1
14	5300	1	29	5300	1
15	5300	1	30	5300	1
Detection Percentage (%)					100%

Radar waveform #1			Radar waveform #2		
Hopping Number	Frequency (MHz)	Pulse Start (ms)	Hopping Number	Frequency (MHz)	Pulse Start (ms)
6	5317	18	3	5297	9
11	5304	33	12	5296	36
59	5299	177	17	5307	51
70	5287	210	21	5274	63
75	5315	225	27	5303	81
80	5316	240	29	5329	87
83	5308	249	31	5316	93
90	5310	270	36	5287	108
--	--	--	38	5298	114
--	--	--	41	5279	123
--	--	--	45	5272	135
--	--	--	47	5327	141
--	--	--	51	5282	153
--	--	--	77	5310	231
--	--	--	78	5289	234
--	--	--	92	5314	276

Radar waveform #3			Radar waveform #4		
Hopping Number	Frequency (MHz)	Pulse Start (ms)	Hopping Number	Frequency (MHz)	Pulse Start (ms)
0	5289	0	1	5309	3
1	5327	3	10	5288	30
6	5291	18	12	5277	36
18	5274	54	20	5287	60
32	5306	96	38	5316	114
43	5283	129	43	5295	129
51	5322	153	71	5276	213
81	5298	243	73	5302	219
86	5320	258	75	5281	225
--	--	--	82	5271	246
--	--	--	90	5307	270
--	--	--	92	5283	276
--	--	--	94	5293	282

Radar waveform #5			Radar waveform #6		
Hopping Number	Frequency (MHz)	Pulse Start (ms)	Hopping Number	Frequency (MHz)	Pulse Start (ms)
7	5311	21	7	5277	21
18	5293	54	9	5314	27
26	5296	78	19	5324	57
37	5303	111	24	5329	72
45	5312	135	29	5306	87
52	6306	156	33	5276	99
66	5308	198	36	5330	108
78	5321	234	43	5289	129
82	5327	246	48	5304	144
86	5304	258	67	5270	201
92	5279	276	71	5288	213
99	5289	297	81	5281	243
--	--	--	89	5272	267
--	--	--	91	5316	273

Radar waveform #7			Radar waveform #8		
-------------------	--	--	-------------------	--	--

Hopping Number	Frequency (MHz)	Pulse Start (ms)	Hopping Number	Frequency (MHz)	Pulse Start (ms)
8	5276	24	7	5279	21
23	5304	69	15	5294	45
28	5305	84	19	5298	57
30	5311	90	25	5325	75
45	5280	135	33	5316	99
47	8270	141	35	5283	105
48	5310	144	36	5324	108
49	5306	147	44	5312	132
51	5275	153	45	5304	135
58	5274	174	47	5270	141
67	5314	201	52	5308	156
70	5329	210	64	5275	192
75	5313	225	67	5289	201
76	5278	228	76	5317	228
81	5271	243	89	5301	267
92	5281	276	91	5285	273

Radar waveform #9			Radar waveform #10		
Hopping Number	Frequency (MHz)	Pulse Start (ms)	Hopping Number	Frequency (MHz)	Pulse Start (ms)
12	5299	36	6	5293	18
20	5319	60	8	5330	24
28	5287	84	11	5306	33
33	5270	99	12	5324	36
41	5311	123	17	5302	51
44	5285	132	18	5320	54
55	5303	165	19	5299	57
93	5273	279	25	5321	75
97	5312	291	45	5310	135
--	--	--	65	5308	195
--	--	--	55	5287	165
--	--	--	56	5327	168
--	--	--	61	5301	183
--	--	--	78	5279	234
--	--	--	90	5289	270
--	--	--	96	5286	288
--	--	--	97	5329	291

Radar waveform #11			Radar waveform #12		
Hopping Number	Frequency (MHz)	Pulse Start (ms)	Frequency (MHz)	Hopping Number	Pulse Start (ms)
7	5312	21	11	5277	33
10	5285	30	18	5320	54
42	5294	126	19	5328	57
48	5309	144	20	5282	60
73	5313	219	25	5318	75
81	5292	243	40	5296	120
92	5293	276	47	5330	141
94	5307	282	51	5329	153
--	--	--	56	5281	168
--	--	--	58	5290	174
--	--	--	60	5285	180
--	--	--	82	5305	246
--	--	--	86	5286	258

Radar waveform #13			Radar waveform #14		
Hopping Number	Frequency (MHz)	Pulse Start (ms)	Hopping Number	Frequency (MHz)	Pulse Start (ms)
1	5307	3	10	5277	30
6	5299	18	21	5288	63
12	5295	36	30	5297	90
14	5313	42	31	5307	93
24	5306	72	35	5279	105
30	5285	90	42	5290	126
49	5315	147	43	5293	129
60	5303	180	45	5313	135
77	5287	231	57	5280	171
78	5323	234	61	5324	183
80	5288	240	71	5295	213
81	5318	243	95	5316	285
97	5283	291	--	--	--

Radar waveform #15	Radar waveform #16
--------------------	--------------------

Hopping Number	Frequency (MHz)	Pulse Start (ms)	Hopping Number	Frequency (MHz)	Pulse Start (ms)
16	5308	48	2	5286	6
27	5307	81	5	5285	15
31	5272	93	14	5281	42
32	5298	96	23	5323	69
44	5317	132	24	5300	72
51	5290	153	25	5324	75
52	5302	156	33	5293	99
57	5316	171	41	5309	123
61	5286	183	42	5274	126
62	5306	186	52	5278	156
64	5311	192	54	5278	162
72	5321	216	56	5295	168
73	5284	219	62	5320	186
74	5328	222	71	5322	213
89	5325	267	--	--	--

Radar waveform #17			Radar waveform #18		
Hopping Number	Frequency (MHz)	Pulse Start (ms)	Hopping Number	Frequency (MHz)	Pulse Start (ms)
12	5318	36	5	5273	15
23	5289	69	9	5288	27
24	5282	72	16	5272	48
54	5307	162	32	5314	96
61	5276	183	33	5307	99
85	5288	255	50	5283	150
87	5298	261	51	5293	153
--	--	--	52	5311	156
--	--	--	55	5295	165
--	--	--	73	5296	219
--	--	--	81	5282	243
--	--	--	84	5287	252
--	--	--	99	5306	297
Radar waveform #19			Radar waveform #20		
Hopping Number	Frequency (MHz)	Pulse Start (ms)	Hopping Number	Frequency (MHz)	Pulse Start (ms)

1	5311	3	0	5319	0
7	5308	21	5	5310	15
13	5320	39	6	5283	18
14	5271	42	18	5302	54
59	5293	177	31	5329	93
61	5305	183	52	5285	156
86	5274	258	53	5303	159
97	5284	291	61	5315	183
--	--	--	69	5312	207
--	--	--	72	5298	216
--	--	--	76	5299	228
--	--	--	77	5230	231

Radar waveform #21			Radar waveform #22		
Hopping Number	Frequency (MHz)	Pulse Start (ms)	Hopping Number	Frequency (MHz)	Pulse Start (ms)
0	5305	0	9	5285	27
23	5303	69	30	5315	90
24	5304	72	31	5313	93
27	5293	81	50	5284	150
43	5319	129	51	5270	153
64	5299	192	53	5307	159
83	5316	249	55	5308	165
87	5289	261	57	5324	171
97	5291	291	60	5279	180
99	5284	297	65	5304	195
--	--	--	77	5311	231
--	--	--	83	5282	249
--	--	--	89	5310	267

Radar waveform #23			Radar waveform #24		
Hopping Number	Frequency (MHz)	Pulse Start (ms)	Hopping Number	Frequency (MHz)	Pulse Start (ms)
0	5291	0	18	5277	54
1	5270	3	24	5310	72
3	5281	9	31	5285	93
4	5289	12	32	5322	96
17	5286	51	34	5301	102
36	5278	108	46	5307	138
48	5316	144	58	5271	174
62	5294	186	66	5292	198
75	5275	225	73	5321	219
77	5298	231	86	5283	258
91	5307	273	88	5282	264
--	--	--	97	5304	291
--	--	--	98	5291	294
--	--	--	99	5302	297

Radar waveform #25			Radar waveform #26		
Hopping Number	Frequency (MHz)	Pulse Start (ms)	Hopping Number	Frequency (MHz)	Pulse Start (ms)
7	5317	21	17	5321	51
9	5278	27	36	5330	108
15	5321	45	43	5322	129
29	5294	87	45	5320	135
37	5272	111	59	5319	177
46	5285	138	68	5287	204
49	5302	147	75	5282	225
51	5324	153	93	5281	279
59	5315	177	97	5277	291
60	5289	180	--	--	--
71	5330	213	--	--	--
76	5314	228	--	--	--
80	5281	240	--	--	--

Radar waveform #27	Radar waveform #28
--------------------	--------------------

Hopping Number	Frequency (MHz)	Pulse Start (ms)	Hopping Number	Frequency (MHz)	Pulse Start (ms)
0	5287	0	3	5299	9
1	5302	3	7	5328	21
10	5274	30	21	5277	63
11	5286	33	31	5306	93
12	5330	36	36	5282	108
21	5281	63	46	5279	138
34	5273	102	58	5287	174
49	5282	147	71	5298	213
56	5298	168	79	5320	237
61	5308	183	90	5327	270
85	5299	255	95	5275	285
88	5314	264	--	--	--
91	5309	273	--	--	--
93	5285	279	--	--	--
94	5313	282	--	--	--

Radar waveform #29			Radar waveform #30		
Hopping Number	Frequency (MHz)	Pulse Start (ms)	Hopping Number	Frequency (MHz)	Pulse Start (ms)
5	5277	15	2	5296	6
10	5326	30	9	5280	27
12	5288	36	10	5297	30
15	5329	45	16	5315	48
16	5318	48	18	5278	54
28	5295	84	49	5282	147
29	5304	87	66	5316	198
32	5322	96	67	5293	201
36	5309	108	78	5305	234
38	5324	114	81	5318	243
45	5287	135	89	5290	267
49	5284	147	--	--	--
53	5293	159	--	--	--
57	5271	171	--	--	--
65	5279	195	--	--	--
68	5330	204	--	--	--
78	5312	234	--	--	--
80	5272	240	--	--	--
84	5323	252	--	--	--
87	5286	261	--	--	--
90	5291	270	--	--	--
96	5292	288	--	--	--

Radar Statistical Performance for 802.11n-HT40

Radar Type 1 - Radar Statistical Performance

Trail #	Test Freq. (MHz)	Pulse Width (us)	PRI (us)	Pulses / Burst	1=Detection 0=No Detection
1	5290	0	918	58	1
2	5290	1	598	89	1
3	5290	1	818	65	1
4	5290	1	658	81	1
5	5290	1	678	78	1
6	5290	1	3066	18	1
7	5290	1	718	74	1
8	5290	1	738	72	1
9	5290	1	898	59	1
10	5290	1	518	102	1
11	5290	1	798	67	1
12	5290	1	578	92	1
13	5290	1	638	83	1
14	5290	1	838	63	1
15	5290	1	758	70	1
16	5290	1	2954	18	1
17	5290	1	1944	28	1
18	5290	1	1283	42	1
19	5290	1	2916	19	1
20	5290	1	2158	25	1
21	5290	1	1244	43	1
22	5290	1	2688	20	1
23	5290	1	595	89	1
24	5290	1	1372	39	1
25	5290	1	1877	29	1
26	5290	1	1010	53	1
27	5290	1	1233	43	1
28	5290	1	2223	24	1
29	5290	1	647	82	1
30	5290	1	2264	24	1
Detection Percentage (%)					100%

Radar Type 2 - Radar Statistical Performance

Trail #	Test Freq. (MHz)	Pulse Width (us)	PRI (us)	Pulses / Burst	1=Detection 0=No Detection
1	5295	2.4	155	27	1
2	5295	4.1	196	23	1
3	5295	1.6	198	23	1
4	5295	1.5	180	26	1
5	5295	3.7	163	29	1
6	5295	2.1	165	26	1
7	5295	2.4	223	23	1
8	5295	2.9	215	26	1
9	5295	1.2	157	26	1
10	5295	1.4	228	25	1
11	5295	1.9	172	27	1
12	5295	3.3	173	28	1
13	5295	1.5	192	29	1
14	5295	3.1	229	26	1
15	5295	2.6	174	28	1
16	5295	1.4	174	27	1
17	5295	3.5	208	24	1
18	5295	3.7	166	27	1
19	5295	2.7	206	29	1
20	5295	4.5	164	25	1
21	5295	4.5	161	23	1
22	5295	3.1	212	24	1
23	5295	3.5	170	27	1
24	5295	3.3	222	26	1
25	5295	1.7	214	24	1
26	5295	2.4	197	28	1
27	5295	1.1	224	26	1
28	5295	2.1	219	24	1
29	5295	2.5	210	25	1
30	5295	3.9	191	26	1
Detection Percentage (%)					100%

Radar Type 3 - Radar Statistical Performance

Trail #	Test Freq. (MHz)	Pulse Width (us)	PRI (us)	Pulses / Burst	1=Detection 0=No Detection
1	5300	7.2	466	16	1
2	5300	7.1	468	18	1
3	5300	7.8	297	18	1
4	5300	6.8	256	18	1
5	5300	8.6	356	17	1
6	5300	7.2	423	16	1
7	5300	7.4	301	17	1
8	5300	7.9	275	18	1
9	5300	8.3	321	18	1
10	5300	9.8	336	17	1
11	5300	6.7	319	17	1
12	5300	7.2	343	17	1
13	5300	8.7	287	17	1
14	5300	8.2	262	17	1
15	5300	9.2	372	16	1
16	5300	6.3	390	18	1
17	5300	7.5	265	17	1
18	5300	6.3	267	17	1
19	5300	8.7	299	18	1
20	5300	9.6	324	16	1
21	5300	8.3	254	18	1
22	5300	9.9	323	18	1
23	5300	6.6	373	17	1
24	5300	8.8	282	17	1
25	5300	7.6	472	18	1
26	5300	6.2	433	16	1
27	5300	6.3	300	17	1
28	5300	8.1	350	16	1
29	5300	9.6	333	17	1
30	5300	9.1	287	18	1
Detection Percentage (%)					100%

Radar Type 4 - Radar Statistical Performance

Trail #	Test Freq. (MHz)	Pulse Width (us)	PRI (us)	Pulses / Burst	1=Detection 0=No Detection
1	5310	11.8	255	13	1
2	5310	18.6	262	13	1
3	5310	13.1	388	15	1
4	5310	13.1	337	13	1
5	5310	12.6	297	13	1
6	5310	15.4	307	12	1
7	5310	13.7	356	15	1
8	5310	16.6	339	14	1
9	5310	16.1	308	13	1
10	5310	16.4	399	15	1
11	5310	19.3	369	14	1
12	5310	19.2	374	16	1
13	5310	12.9	283	16	1
14	5310	13.8	498	15	1
15	5310	18.5	483	13	1
16	5310	16.5	360	14	1
17	5310	15.8	368	15	1
18	5310	15.8	474	16	0
19	5310	11.2	389	15	1
20	5310	18.9	317	12	1
21	5310	15.1	287	12	1
22	5310	11.1	396	13	1
23	5310	17.1	424	15	1
24	5310	17.0	266	16	1
25	5310	12.9	265	14	1
26	5310	15.0	494	15	1
27	5310	19.7	490	13	1
28	5310	15.4	275	12	0
29	5310	12.2	461	13	1
30	5310	11.3	307	15	1
Detection Percentage (%)					93.3%

Note: In addition an average minimum percentage of successful detection across all four Short pulse radar test

waveforms is as follows: $\frac{P_d1 + P_d2 + P_d3 + P_d4}{4} = (100\% + 100\% + 100\% + 93.3\%) / 4 = 98.3\% (>80\%)$



Radar Type 5 - Radar Statistical Performance

Trail #	Test Freq. (MHz)	1=Detection 0=No Detection	Trail #	Test Freq. (MHz)	1=Detection 0=No Detection
1	5329	1	16	5329	1
2	5329	1	17	5329	1
3	5329	1	18	5329	1
4	5329	1	19	5329	1
5	5329	1	20	5329	1
6	5329	1	21	5329	1
7	5329	1	22	5329	1
8	5329	1	23	5329	1
9	5329	1	24	5329	1
10	5329	1	25	5329	1
11	5329	1	26	5329	1
12	5329	1	27	5329	1
13	5329	1	28	5329	1
14	5329	1	29	5329	1
15	5329	1	30	5329	1
Detection Percentage (%)					100%

Type 5 Radar Waveform_1										
1 Waveform Num = 1 Num of Bursts = 10 Burst Interval (us)= 1200000										
Burst #	Off Time (us)	# Pulses	Chirp (MHz)	PW (us)	Pulse 1 Pri(us)	Pulse 2 Pri(us)	Pulse 3 Pri(us)	Start Loc (us)	Start Burst Interval(us)	End Burst Interval(us)
1	172689	2	19	80	1268	1022	0	172689	0	1199999
2	1516620	3	6	100	1284	1081	1518	1691599	1200000	2399999
3	1383664	1	9	75	1886	0	0	3079146	2400000	3599999
4	890488	1	11	100	1370	0	0	3971520	3600000	4799999
5	1491084	1	12	100	1068	0	0	5463974	4800000	5999999
6	1387190	1	10	80	1469	0	0	6852232	6000000	7199999
7	645322	3	13	75	1446	1820	1949	7499023	7200000	8399999
8	1127336	3	19	50	1147	1852	1754	8631574	8400000	9599999
9	1742265	3	13	70	1255	1544	1191	10378592	9600000	10799999
10	572804	1	20	50	1081	0	0	10955386	10800000	11999999
Total number of pulses in waveform = 19 *****										



Type 5 Radar Waveform_2

Waveform Num = 2
Num of Bursts = 10
Burst Interval (us)= 1200000

Burst #	Off Time (us)	# Pulses	Chirp (MHz)	PW (us)	Pulse 1 Pri(us)	Pulse 2 Pri(us)	Pulse 3 Pri(us)	Start Loc (us)	Start Burst Interval (us)	End Burst Interval (us)
1	815604	3	13	90	1511	1634	1041	815604	0	1199999
2	1510565	2	20	65	1978	1378	0	2330355	1200000	2399999
3	1179648	3	10	70	1232	1810	1433	3513359	2400000	3599999
4	1171133	1	19	95	1498	0	0	4688967	3600000	4799999
5	1281967	3	7	80	1100	1992	1277	5972432	4800000	5999999
6	856408	3	6	100	1492	1301	1203	6833209	6000000	7199999
7	1505717	1	7	65	1794	0	0	8342922	7200000	8399999
8	496860	1	13	90	1341	0	0	8841576	8400000	9599999
9	1245180	3	14	50	1020	1222	1109	10088097	9600000	10799999
10	1594012	1	6	70	1898	0	0	11685460	10800000	11999999

Total number of pulses in waveform = 21

Type 5 Radar Waveform_3

Waveform Num = 3
Num of Bursts = 9
Burst Interval (us)= 1333333

Burst #	Off Time (us)	# Pulses	Chirp (MHz)	PW (us)	Pulse 1 Pri(us)	Pulse 2 Pri(us)	Pulse 3 Pri(us)	Start Loc (us)	Start Burst Interval (us)	End Burst Interval (us)
1	904644	2	17	90	1962	1309	0	904644	0	1333332
2	555654	2	14	65	1317	1019	0	1463569	1333333	2666665
3	1695977	3	18	90	1840	1873	1150	3161882	2666666	3999998
4	1678856	3	5	65	1463	1268	1733	4845601	3999999	5333331
5	1612166	1	5	80	1753	0	0	6462231	5333332	6666664
6	1139966	2	15	100	1434	1107	0	7603950	6666665	7999997
7	1363286	1	5	85	1261	0	0	8969777	7999998	9333330
8	1199679	3	5	65	1449	1306	1437	10170717	9333331	10666663
9	1229297	1	6	50	1137	0	0	11404206	10666664	11999996

Total number of pulses in waveform = 18

Type 5 Radar Waveform_4

Waveform Num = 4
Num of Bursts = 9
Burst Interval (us)= 1333333

Burst #	Off Time (us)	# Pulses	Chirp (MHz)	PW (us)	Pulse 1 Pri(us)	Pulse 2 Pri(us)	Pulse 3 Pri(us)	Start Loc (us)	Start Burst Interval (us)	End Burst Interval (us)
1	992794	1	5	75	1160	0	0	992794	0	1333332
2	413460	3	19	85	1743	1313	1376	1407414	1333333	2666665
3	1850466	3	15	75	1170	1104	1342	3262312	2666666	3999998
4	1076022	3	18	95	1740	1452	1947	4341950	3999999	5333331
5	2009676	3	13	65	1217	1870	1203	6356765	5333332	6666664
6	1033775	1	7	55	1850	0	0	7394830	6666665	7999997
7	1111569	3	10	65	1132	1646	1062	8508249	7999998	9333330
8	2125188	2	10	80	1877	1762	0	10637277	9333331	10666663
9	842400	3	19	70	1176	1925	1177	11483316	10666664	11999996

Total number of pulses in waveform = 22



Type 5 Radar Waveform_5

Waveform Num = 5
Num of Bursts = 16
Burst Interval (us)= 750000

Burst #	Off Time (us)	# Pulses	Chirp (MHz)	PW (us)	Pulse 1 Pri (us)	Pulse 2 Pri (us)	Pulse 3 Pri (us)	Start Loc (us)	Start Burst Interval (us)	End Burst Interval (us)
1	153625	2	12	70	1356	1443	0	153625	0	749999
2	962348	2	14	65	1700	1692	0	1118772	750000	1499999
3	380306	3	12	50	1998	1279	1165	1502470	1500000	2249999
4	1133794	3	20	85	1517	1058	1878	2640706	2250000	2999999
5	747635	3	12	90	1941	1759	1170	3392794	3000000	3749999
6	1090281	1	5	55	1472	0	0	4487945	3750000	4499999
7	701863	2	9	95	1503	1082	0	5191080	4500000	5249999
8	689394	3	8	75	1423	1348	1921	5883059	5250000	5999999
9	260397	1	14	95	1119	0	0	6148148	6000000	6749999
10	1146249	2	18	75	1637	1017	0	7295516	6750000	7499999
11	458249	3	9	55	1380	1994	1057	7756419	7500000	8249999
12	1102091	2	16	100	1617	1940	0	8862941	8250000	8999999
13	534673	2	10	65	1165	1559	0	9401171	9000000	9749999
14	535517	2	9	85	1895	1242	0	9939412	9750000	10499999
15	1222144	3	15	75	1041	1921	1232	11164693	10500000	11249999
16	612656	3	9	70	1798	1729	1893	11781543	11250000	11999999

Total number of pulses in waveform = 37

Type 5 Radar Waveform_6

Waveform Num = 6
Num of Bursts = 16
Burst Interval (us)= 750000

Burst #	Off Time (us)	# Pulses	Chirp (MHz)	PW (us)	Pulse 1 Pri (us)	Pulse 2 Pri (us)	Pulse 3 Pri (us)	Start Loc (us)	Start Burst Interval (us)	End Burst Interval (us)
1	60173	1	12	65	1327	0	0	60173	0	749999
2	939985	2	10	100	1483	1616	0	1001485	750000	1499999
3	848673	1	20	75	1191	0	0	1853257	1500000	2249999
4	742139	1	8	90	1740	0	0	2596587	2250000	2999999
5	595892	2	19	80	1777	1522	0	3194219	3000000	3749999
6	1097055	2	17	80	1865	1540	0	4294573	3750000	4499999
7	935405	2	14	85	1499	1609	0	5233383	4500000	5249999
8	658867	1	8	100	1373	0	0	5892358	5250000	5999999
9	471551	3	16	55	1250	1639	1607	6365282	6000000	6749999
10	1118315	3	6	50	1898	1885	1874	7488093	6750000	7499999
11	179113	2	12	80	1810	1591	0	7672863	7500000	8249999
12	936894	1	10	75	1308	0	0	8613158	8250000	8999999
13	1040596	1	8	95	1903	0	0	9655062	9000000	9749999
14	331705	3	20	95	1874	1807	1362	9888670	9750000	10499999
15	1117335	2	20	50	1036	1998	0	11111048	10500000	11249999
16	350958	3	18	55	1049	1119	1346	11465040	11250000	11999999

Total number of pulses in waveform = 30

Type 5 Radar Waveform_7

Waveform Num = 7
Num of Bursts = 9
Burst Interval (us)= 1333333

Burst #	Off Time (us)	# Pulses	Chirp (MHz)	PW (us)	Pulse 1 Pri (us)	Pulse 2 Pri (us)	Pulse 3 Pri (us)	Start Loc (us)	Start Burst Interval (us)	End Burst Interval (us)
1	461580	3	18	55	1483	1049	1359	461580	0	1333332
2	1580239	3	13	85	1284	1540	1017	2045710	1333333	2666665
3	1280146	1	11	50	1760	0	0	3329697	2666666	3999998
4	1917091	1	13	75	1453	0	0	5248548	3999999	5333331
5	1379959	3	15	75	1290	1218	1584	6629960	5333332	6666664
6	154375	2	7	50	1735	1770	0	6788427	6666665	7999997
7	1852659	2	19	90	1695	1410	0	8644591	7999998	9333330
8	886174	3	16	100	1964	1214	1112	9533870	9333331	10666663
9	1844096	3	19	50	1886	1516	1063	11382256	10666664	11999996

Total number of pulses in waveform = 21



Type 5 Radar Waveform_8

Waveform Num = 8
Num of Bursts = 18
Burst Interval (us) = 666667

Burst #	Off Time (us)	# Pulses	Chirp (MHz)	PW (us)	Pulse 1 Pri (us)	Pulse 2 Pri (us)	Pulse 3 Pri (us)	Start Loc (us)	Start Burst Interval (us)	End Burst Interval (us)
1	287336	1	9	90	1294	0	0	287336	0	666666
2	526759	2	18	55	1177	1583	0	815389	666667	1333333
3	600801	2	11	90	1837	1923	0	1418950	1333334	2000000
4	1168422	1	18	95	1025	0	0	2591132	2000001	2666667
5	506586	2	16	90	1555	1727	0	3098743	2666668	3333334
6	373144	2	9	65	1742	1082	0	3475169	3333335	4000001
7	790026	3	17	70	1767	1586	1335	4268019	4000002	4666668
8	536686	2	6	85	1263	1497	0	4809393	4666669	5333335
9	1016010	2	9	55	1305	1492	0	5828163	5333336	6000002
10	768452	3	20	65	1882	1489	1450	6599412	6000003	6666669
11	363711	2	8	55	1664	1326	0	6967944	6666670	7333336
12	888733	1	12	65	1738	0	0	7859667	7333337	8000003
13	174945	2	11	60	1303	1026	0	8036350	8000004	8666670
14	916007	2	16	100	1937	1826	0	8954686	8666671	9333337
15	615131	2	16	100	1425	1250	0	9573580	9333338	10000004
16	439254	2	10	100	1272	1850	0	10015509	10000005	10666671
17	1224576	2	7	55	1437	1607	0	11243207	10666672	11333338
18	673379	3	13	55	1436	1157	1450	11919630	11333339	12000005

Total number of pulses in waveform = 36

Type 5 Radar Waveform_9

Waveform Num = 9
Num of Bursts = 11
Burst Interval (us) = 1090909

Burst #	Off Time (us)	# Pulses	Chirp (MHz)	PW (us)	Pulse 1 Pri (us)	Pulse 2 Pri (us)	Pulse 3 Pri (us)	Start Loc (us)	Start Burst Interval (us)	End Burst Interval (us)
1	132701	2	19	100	1580	1412	0	132701	0	1090908
2	1783092	1	20	60	1027	0	0	1918785	1090909	2181817
3	497515	3	16	55	1097	1451	1549	2417327	2181818	3272726
4	898440	1	7	65	1386	0	0	3319864	3272727	4363635
5	2088470	3	20	90	1249	1240	1198	5409720	4363636	5454544
6	185007	2	14	70	1471	1637	0	5598414	5454545	6545453
7	1487025	3	13	90	1371	1782	1036	7088547	6545454	7636362
8	1094372	2	7	100	1745	1987	0	8187108	7636363	8727271
9	741952	2	17	80	1814	1833	0	8932792	8727272	9818180
10	1950627	3	5	70	1626	1932	1658	10887066	9818181	10909089
11	812520	1	5	70	1008	0	0	11704802	10909090	11999998

Total number of pulses in waveform = 23

Type 5 Radar Waveform_10

Waveform Num = 10
Num of Bursts = 18
Burst Interval (us) = 666667

Burst #	Off Time (us)	# Pulses	Chirp (MHz)	PW (us)	Pulse 1 Pri (us)	Pulse 2 Pri (us)	Pulse 3 Pri (us)	Start Loc (us)	Start Burst Interval (us)	End Burst Interval (us)
1	539578	1	18	95	1649	0	0	539578	0	666666
2	555257	2	9	90	1632	1278	0	1096484	666667	1333333
3	417194	2	20	85	1163	1773	0	1516588	1333334	2000000
4	928063	1	17	95	1489	0	0	2447587	2000001	2666667
5	548383	1	16	85	1722	0	0	2997459	2666668	3333334
6	395113	2	19	55	1542	1736	0	3394294	3333335	4000001
7	1114830	2	17	90	1697	1952	0	4512402	4000002	4666668
8	155940	2	20	100	1192	1899	0	4671991	4666669	5333335
9	1308292	2	14	90	1633	1472	0	5983374	5333336	6000002
10	528700	1	19	95	1742	0	0	6515179	6000003	6666669
11	719980	2	5	95	1336	1948	0	7236901	6666670	7333336
12	475210	2	5	50	1262	1599	0	7715395	7333337	8000003
13	327524	3	7	80	1486	1657	1003	8045770	8000004	8666670
14	1093400	2	13	100	1948	1189	0	9143316	8666671	9333337
15	704931	3	8	95	1326	1147	1931	9851384	9333338	10000004
16	453255	3	11	65	1353	1835	1379	10309043	10000005	10666671
17	416423	3	9	60	1648	1845	1728	10730033	10666672	11333338
18	683477	2	6	60	1857	1685	0	11418731	11333339	12000005

Total number of pulses in waveform = 36



Type 5 Radar Waveform_11

Waveform Num = 11
Num of Bursts = 10
Burst Interval (us)= 1200000

Burst #	Off Time (us)	# Pulses	Chirp (MHz)	PW (us)	Pulse 1 Pri (us)	Pulse 2 Pri (us)	Pulse 3 Pri (us)	Start Loc (us)	Start Burst Interval (us)	End Burst Interval (us)
1	393450	2	6	100	1838	1940	0	393450	0	1199999
2	1882266	1	14	65	1300	0	0	2279494	1200000	2399999
3	547605	3	14	85	1977	1437	1160	2828399	2400000	3599999
4	1260363	2	14	100	1439	1044	0	4093336	3600000	4799999
5	1450511	1	19	85	1937	0	0	5546330	4800000	5999999
6	799291	3	9	90	1178	1128	1823	6347558	6000000	7199999
7	1208044	3	19	55	1823	1805	1524	7559731	7200000	8399999
8	1105271	2	12	100	1832	1309	0	8670154	8400000	9599999
9	1470152	1	12	80	1089	0	0	10143447	9600000	10799999
10	1605722	3	5	75	1105	1188	1805	11750258	10800000	11999999

Total number of pulses in waveform = 21

Type 5 Radar Waveform_12

Waveform Num = 12
Num of Bursts = 9
Burst Interval (us)= 1333333

Burst #	Off Time (us)	# Pulses	Chirp (MHz)	PW (us)	Pulse 1 Pri (us)	Pulse 2 Pri (us)	Pulse 3 Pri (us)	Start Loc (us)	Start Burst Interval (us)	End Burst Interval (us)
1	371	3	13	65	1237	1802	1433	371	0	1333332
2	2143069	2	17	65	1869	1710	0	2147912	1333333	2666665
3	743731	3	19	55	1666	1606	1938	2895222	2666666	3999998
4	2362619	3	13	65	1178	1704	1797	5263051	3999999	5333331
5	1080484	3	18	90	1715	1395	1134	6348214	5333332	6666664
6	969130	3	16	95	1811	1456	1475	7321588	6666665	7999997
7	677753	2	8	90	1033	1836	0	8004083	7999998	9333330
8	2554757	2	7	55	1597	1650	0	10561709	9333331	10666663
9	388336	3	13	65	1777	1330	1094	10953292	10666664	11999996

Total number of pulses in waveform = 24

Type 5 Radar Waveform_13

Waveform Num = 13
Num of Bursts = 19
Burst Interval (us)= 631579

Burst #	Off Time (us)	# Pulses	Chirp (MHz)	PW (us)	Pulse 1 Pri (us)	Pulse 2 Pri (us)	Pulse 3 Pri (us)	Start Loc (us)	Start Burst Interval (us)	End Burst Interval (us)
1	485532	3	5	50	1546	1608	1001	485532	0	631578
2	552925	2	7	95	1527	1206	0	1042612	631579	1263157
3	414175	1	6	70	1601	0	0	1459520	1263158	1894736
4	940078	3	17	95	1134	1382	1690	2401199	1894737	2526315
5	328391	3	14	90	1322	1064	1463	2733796	2526316	3157894
6	971573	3	20	80	1542	1435	1075	3709218	3157895	3789473
7	526430	1	5	65	1955	0	0	4239701	3789474	4421052
8	392605	3	6	65	1916	1770	1456	4634261	4421053	5052631
9	824443	3	9	80	1002	1963	1583	5463846	5052632	5684210
10	504088	1	14	55	1823	0	0	5972482	5684211	6315789
11	873287	2	12	70	1859	1760	0	6847592	6315790	6947368
12	589450	2	16	95	1267	1052	0	7440661	6947369	7578947
13	687844	1	20	90	1078	0	0	8130824	7578948	8210526
14	287841	3	19	65	1915	1633	1537	8419743	8210527	8842105
15	1002457	2	9	50	1633	1834	0	9427285	8842106	9473684
16	657844	3	13	95	1327	1978	1194	10088596	9473685	10105263
17	379449	2	16	60	1836	1953	0	10472544	10105264	10736842
18	598185	2	15	100	1429	1382	0	11074518	10736843	11368421
19	622414	1	7	55	1931	0	0	11699743	11368422	12000000

Total number of pulses in waveform = 41



Type 5 Radar Waveform_14

Waveform Num = 14
Num of Bursts = 10
Burst Interval (us)= 1200000

Burst #	Off Time (us)	# Pulses	Chirp (MHz)	PW (us)	Pulse 1 Pri (us)	Pulse 2 Pri (us)	Pulse 3 Pri (us)	Start Loc (us)	Start Burst Interval (us)	End Burst Interval (us)
1	72995	3	12	80	1046	1689	1896	72995	0	1199999
2	2269957	2	10	95	1693	1468	0	2347583	1200000	2399999
3	444623	3	15	100	1776	1885	1087	2795367	2400000	3599999
4	1933907	3	5	85	1561	1441	1994	4734022	3600000	4799999
5	908627	3	10	80	1360	1281	1326	5647645	4800000	5999999
6	1512003	1	9	55	1259	0	0	7163615	6000000	7199999
7	887685	3	13	55	1006	1054	1623	8052559	7200000	8399999
8	741123	1	16	100	1460	0	0	8797365	8400000	9599999
9	1330367	3	11	95	1949	1818	1315	10129192	9600000	10799999
10	1793079	2	5	70	1380	1367	0	11927353	10800000	11999999

Total number of pulses in waveform = 24

Type 5 Radar Waveform_15

Waveform Num = 15
Num of Bursts = 19
Burst Interval (us)= 631579

Burst #	Off Time (us)	# Pulses	Chirp (MHz)	PW (us)	Pulse 1 Pri (us)	Pulse 2 Pri (us)	Pulse 3 Pri (us)	Start Loc (us)	Start Burst Interval (us)	End Burst Interval (us)
1	199113	2	7	65	1341	1707	0	199113	0	631578
2	1035948	3	6	100	1422	1268	1594	1238109	631579	1263157
3	547275	3	20	80	1843	1842	1182	1789668	1263158	1894736
4	547534	3	12	60	1911	1166	1685	2342069	1894737	2526315
5	222889	2	7	60	1052	1108	0	2569520	2526316	3157894
6	873015	3	8	55	1492	1465	1852	3444895	3157895	3789473
7	348131	1	6	65	1321	0	0	3797635	3789474	4421052
8	624587	1	12	95	1613	0	0	4423543	4421053	5052631
9	1131825	1	17	60	1179	0	0	5556981	5052632	5684210
10	469778	2	12	55	1569	1546	0	6027938	5684211	6315789
11	639736	3	5	80	1259	1517	1381	6670789	6315790	6947368
12	634228	2	18	70	1422	1084	0	7309174	6947369	7578947
13	712189	1	7	100	1858	0	0	8023869	7578948	8210526
14	533208	1	5	70	1852	0	0	8558935	8210527	8842105
15	577746	2	19	70	1817	1843	0	9138533	8842106	9473684
16	490975	3	10	90	1514	1736	1219	9633168	9473685	10105263
17	1023967	3	9	50	1860	1116	1637	10661604	10105264	10736842
18	531601	2	6	55	1523	1615	0	11197818	10736843	11368421
19	529850	2	18	70	1265	1423	0	11730806	11368422	12000000

Total number of pulses in waveform = 40

Type 5 Radar Waveform_16

Waveform Num = 16
Num of Bursts = 11
Burst Interval (us)= 1090909

Burst #	Off Time (us)	# Pulses	Chirp (MHz)	PW (us)	Pulse 1 Pri (us)	Pulse 2 Pri (us)	Pulse 3 Pri (us)	Start Loc (us)	Start Burst Interval (us)	End Burst Interval (us)
1	49571	3	12	90	1634	1101	1007	49571	0	1090908
2	1704611	2	6	70	1565	1948	0	1757924	1090909	2181817
3	849785	2	10	50	1565	1380	0	2611222	2181818	3272726
4	1363843	3	19	90	1187	1694	1279	3978010	3272727	4363635
5	760064	3	9	60	1268	1996	1053	4742234	4363636	5454544
6	1224849	2	15	65	1082	1965	0	5971400	5454545	6545453
7	1445165	2	10	80	1175	1499	0	7419612	6545454	7636362
8	1213009	2	8	70	1953	1711	0	8635295	7636363	8727271
9	1028690	3	19	85	1334	1483	1226	9667649	8727272	9818180
10	835494	1	8	90	1135	0	0	10507186	9818181	10909089
11	1441540	2	10	55	1800	1454	0	11949861	10909090	11999998

Total number of pulses in waveform = 25



Type 5 Radar Waveform_17

Waveform Num = 17
Num of Bursts = 15
Burst Interval (us)= 800000

Burst #	Off Time (us)	# Pulses	Chirp (MHz)	PW (us)	Pulse 1 Pri (us)	Pulse 2 Pri (us)	Pulse 3 Pri (us)	Start Loc (us)	Start Burst Interval (us)	End Burst Interval (us)
1	319088	3	14	85	1030	1575	1467	319088	0	799999
2	968700	1	15	80	1993	0	0	1291860	800000	1599999
3	704534	1	11	70	1272	0	0	1998387	1600000	2399999
4	931734	2	15	55	1323	1634	0	2931393	2400000	3199999
5	748330	1	18	65	1902	0	0	3682680	3200000	3999999
6	786112	1	7	90	1261	0	0	4470694	4000000	4799999
7	332956	1	12	60	1690	0	0	4804911	4800000	5599999
8	860043	1	20	70	1915	0	0	5666644	5600000	6399999
9	1193034	2	20	90	1456	1720	0	6861593	6400000	7199999
10	842983	3	5	85	1165	1118	1186	7707752	7200000	7999999
11	805970	1	15	75	1941	0	0	8517191	8000000	8799999
12	554429	2	5	55	1144	1247	0	9073561	8800000	9599999
13	641125	1	12	90	1479	0	0	9717077	9600000	10399999
14	1377030	1	8	65	1797	0	0	11095586	10400000	11199999
15	157996	1	9	50	1211	0	0	11255379	11200000	11999999

Total number of pulses in waveform = 22

Type 5 Radar Waveform_18

Waveform Num = 18
Num of Bursts = 13
Burst Interval (us)= 923077

Burst #	Off Time (us)	# Pulses	Chirp (MHz)	PW (us)	Pulse 1 Pri (us)	Pulse 2 Pri (us)	Pulse 3 Pri (us)	Start Loc (us)	Start Burst Interval (us)	End Burst Interval (us)
1	126024	3	18	55	1020	1505	1293	126024	0	923076
2	1053810	1	18	65	1483	0	0	1183652	923077	1846153
3	867821	1	17	85	1850	0	0	2052956	1846154	2769230
4	1172680	1	14	75	1591	0	0	3227486	2769231	3692307
5	1077486	1	10	95	1491	0	0	4306563	3692308	4615384
6	502047	2	13	85	1179	1957	0	4810101	4615385	5538461
7	1507860	2	5	90	1853	1486	0	6321097	5538462	6461538
8	354559	1	12	70	1593	0	0	6678995	6461539	7384615
9	1539327	2	12	50	1820	1495	0	8219915	7384616	8307692
10	886780	1	12	65	1059	0	0	9110010	8307693	9230769
11	199405	3	20	50	1671	1362	1110	9310474	9230770	10153846
12	1320688	2	17	50	1854	1362	0	10635305	10153847	11076923
13	811155	2	9	50	1951	1967	0	11449676	11076924	12000000

Total number of pulses in waveform = 22

Type 5 Radar Waveform_19

Waveform Num = 19
Num of Bursts = 10
Burst Interval (us)= 1200000

Burst #	Off Time (us)	# Pulses	Chirp (MHz)	PW (us)	Pulse 1 Pri (us)	Pulse 2 Pri (us)	Pulse 3 Pri (us)	Start Loc (us)	Start Burst Interval (us)	End Burst Interval (us)
1	1030017	1	18	90	1525	0	0	1030017	0	1199999
2	851782	3	11	75	1586	1871	1005	1883324	1200000	2399999
3	1220059	1	5	65	1772	0	0	3107845	2400000	3599999
4	494063	3	16	50	1066	1620	1936	3603680	3600000	4799999
5	1202715	3	6	65	1654	1124	1438	4811017	4800000	5999999
6	2223994	3	14	70	1304	1839	1357	7039227	6000000	7199999
7	1131545	3	12	65	1875	1357	1434	8175272	7200000	8399999
8	417403	1	18	70	1069	0	0	8597341	8400000	9599999
9	2024510	2	6	50	1434	1071	0	10622920	9600000	10799999
10	332034	2	12	60	1760	1683	0	10957459	10800000	11999999

Total number of pulses in waveform = 22



Type 5 Radar Waveform_20

Waveform Num = 20
Num of Bursts = 12
Burst Interval (us)= 1000000

Burst #	Off Time (us)	# Pulses	Chirp (MHz)	PW (us)	Pulse 1 Pri(us)	Pulse 2 Pri(us)	Pulse 3 Pri(us)	Start Loc (us)	Start Burst Interval (us)	End Burst Interval (us)
1	942185	1	6	65	1231	0	0	942185	0	999999
2	847375	2	16	65	1549	1014	0	1790791	1000000	1999999
3	626128	2	14	75	1772	1721	0	2419482	2000000	2999999
4	717488	3	10	60	1570	1575	1990	3140463	3000000	3999999
5	1144453	2	12	100	1492	1151	0	4290051	4000000	4999999
6	1159889	3	11	90	1987	1824	1178	5452583	5000000	5999999
7	1519835	3	16	95	1520	1196	1959	6977407	6000000	6999999
8	487425	3	9	60	1227	1598	1244	7469507	7000000	7999999
9	540603	3	18	70	1866	1594	1837	8014179	8000000	8999999
10	1083730	1	7	90	1866	0	0	9103206	9000000	9999999
11	1035908	2	15	85	1210	1818	0	10140980	10000000	10999999
12	1118561	3	16	75	1670	1092	1235	11262569	11000000	11999999

Total number of pulses in waveform = 28

Type 5 Radar Waveform_21

Waveform Num = 21
Num of Bursts = 16
Burst Interval (us)= 750000

Burst #	Off Time (us)	# Pulses	Chirp (MHz)	PW (us)	Pulse 1 Pri(us)	Pulse 2 Pri(us)	Pulse 3 Pri(us)	Start Loc (us)	Start Burst Interval (us)	End Burst Interval (us)
1	79715	1	17	90	1160	0	0	79715	0	749999
2	1030308	1	14	50	1057	0	0	1111183	750000	1499999
3	869674	3	17	100	1819	1055	1748	1981914	1500000	2249999
4	767801	2	8	70	1628	1780	0	2754337	2250000	2999999
5	379962	3	17	95	1870	1322	1623	3137707	3000000	3749999
6	1112706	3	5	65	1764	1063	1439	4255228	3750000	4499999
7	804025	1	6	80	1570	0	0	5063519	4500000	5249999
8	422633	2	17	65	1094	1212	0	5487722	5250000	5999999
9	577317	3	10	75	1882	1274	1741	6067345	6000000	6749999
10	762963	3	19	70	1294	1433	1133	6835205	6750000	7499999
11	1150321	2	16	90	1021	1807	0	7989386	7500000	8249999
12	567263	3	9	50	1996	1698	1427	8559477	8250000	8999999
13	1166822	3	13	50	1553	1587	1134	9731420	9000000	9749999
14	283314	2	19	70	1399	1666	0	10019008	9750000	10499999
15	1093011	3	12	85	1818	1076	1998	11115084	10500000	11249999
16	350328	2	7	80	1895	1088	0	11470304	11250000	11999999

Total number of pulses in waveform = 37

Type 5 Radar Waveform_22

Waveform Num = 22
Num of Bursts = 13
Burst Interval (us)= 923077

Burst #	Off Time (us)	# Pulses	Chirp (MHz)	PW (us)	Pulse 1 Pri(us)	Pulse 2 Pri(us)	Pulse 3 Pri(us)	Start Loc (us)	Start Burst Interval (us)	End Burst Interval (us)
1	889699	2	15	50	1291	1934	0	889699	0	923076
2	649791	1	5	80	1460	0	0	1542715	923077	1846153
3	958829	3	10	80	1241	1547	1551	2503004	1846154	2769230
4	608467	3	18	65	1721	1996	1361	3115810	2769231	3692307
5	759037	3	15	80	1806	1210	1370	3879925	3692308	4615384
6	1646876	2	11	80	1292	1261	0	5531187	4615385	5538461
7	85743	1	12	50	1864	0	0	5619483	5538462	6461538
8	1523070	3	10	80	1038	1805	1826	7144417	6461539	7384615
9	258465	1	12	70	1576	0	0	7407551	7384616	8307692
10	1724636	2	10	95	1082	1886	0	9133763	8307693	9230769
11	930443	1	5	50	1611	0	0	10066974	9230770	10153846
12	798425	1	9	95	1498	0	0	10867010	10153847	11076923
13	670901	3	11	90	1126	1018	1504	11539409	11076924	12000000

Total number of pulses in waveform = 26



Type 5 Radar Waveform_23

Waveform Num = 23
Num of Bursts = 10
Burst Interval (us)= 1200000

Burst #	Off Time (us)	# Pulses	Chirp (MHz)	PW (us)	Pulse 1 Pri (us)	Pulse 2 Pri (us)	Pulse 3 Pri (us)	Start Loc (us)	Start Burst Interval (us)	End Burst Interval (us)
1	678162	3	7	60	1538	1290	1669	678162	0	1199999
2	686784	3	20	55	1098	1981	1298	1369443	1200000	2399999
3	1375563	1	15	100	1330	0	0	2749383	2400000	3599999
4	886308	2	12	85	1892	1126	0	3637021	3600000	4799999
5	2356840	1	6	75	1422	0	0	5996879	4800000	5999999
6	159788	3	12	70	1459	1614	1318	6158089	6000000	7199999
7	1395813	2	11	75	1000	1856	0	7558293	7200000	8399999
8	1326953	1	14	50	1210	0	0	8888102	8400000	9599999
9	910653	3	12	70	1595	1235	1484	9799965	9600000	10799999
10	1497959	1	7	60	1568	0	0	11302238	10800000	11999999

Total number of pulses in waveform = 20

Type 5 Radar Waveform_24

Waveform Num = 24
Num of Bursts = 18
Burst Interval (us)= 666667

Burst #	Off Time (us)	# Pulses	Chirp (MHz)	PW (us)	Pulse 1 Pri (us)	Pulse 2 Pri (us)	Pulse 3 Pri (us)	Start Loc (us)	Start Burst Interval (us)	End Burst Interval (us)
1	325587	3	16	95	1560	1752	1479	325587	0	666666
2	451450	1	20	80	1285	0	0	781818	666667	1333333
3	582655	3	12	85	1587	1765	1825	1365758	1333334	2000000
4	1024645	2	20	85	1155	1376	0	2395580	2000001	2666667
5	658466	1	14	100	1005	0	0	3056567	2666668	3333334
6	756973	1	10	95	1033	0	0	3814545	3333335	4000001
7	569728	3	11	70	1247	1725	1684	4375306	4000002	4666668
8	411004	3	17	75	1625	1484	1535	4790966	4666669	5333335
9	774581	3	15	75	1958	1736	1097	5570191	5333336	6000002
10	693733	1	14	90	1843	0	0	6268715	6000003	6666669
11	1008928	2	11	85	1788	1644	0	7279486	6666670	7333336
12	432520	3	17	60	1289	1529	1475	7715438	7333337	8000003
13	780714	2	17	50	1095	1576	0	8500445	8000004	8666670
14	425563	1	14	90	1325	0	0	8928679	8666671	9333337
15	930774	2	15	90	1906	1072	0	9860778	9333338	10000004
16	522647	2	20	100	1919	1818	0	10386403	10000005	10666671
17	775082	3	15	100	1379	1907	1275	11165222	10666672	11333338
18	167448	1	18	95	1751	0	0	11337231	11333339	12000005

Total number of pulses in waveform = 37

Type 5 Radar Waveform_25

Waveform Num = 25
Num of Bursts = 17
Burst Interval (us)= 705882

Burst #	Off Time (us)	# Pulses	Chirp (MHz)	PW (us)	Pulse 1 Pri (us)	Pulse 2 Pri (us)	Pulse 3 Pri (us)	Start Loc (us)	Start Burst Interval (us)	End Burst Interval (us)
1	585961	3	19	55	1782	1243	1996	585961	0	705881
2	412883	3	18	100	1172	1689	1699	1003845	705882	1411763
3	424153	2	15	90	1400	1009	0	1432568	1411764	2117645
4	1298799	2	10	65	1957	1847	0	2733766	2117646	2823527
5	377032	2	6	85	1318	1694	0	3114602	2823528	3529409
6	611236	3	19	55	1645	1755	1988	3728850	3529410	4235291
7	929762	2	12	75	1836	1709	0	4664000	4235292	4941173
8	812096	3	10	70	1130	1578	1121	5479641	4941174	5647055
9	761598	1	9	75	1102	0	0	6245068	5647056	6352937
10	382446	2	9	70	1208	1873	0	6628616	6352938	7058819
11	995516	1	16	90	1818	0	0	7627213	7058820	7764701
12	667057	3	5	100	1450	1244	1049	8296088	7764702	8470583
13	681490	1	10	100	1913	0	0	8981321	8470584	9176465
14	364212	1	7	65	1425	0	0	9347446	9176466	9882347
15	703421	1	15	95	1263	0	0	10052292	9882348	10588229
16	1227929	2	10	55	1475	1197	0	11281484	10588230	11294111
17	91622	3	13	50	1532	1159	1576	11375778	11294112	11999993

Total number of pulses in waveform = 35



Type 5 Radar Waveform_26

```

Waveform Num = 26
Num of Bursts = 19
Burst Interval (us) = 631579

```

Burst #	Off Time (us)	# Pulses	Chirp (MHz)	PW (us)	Pulse 1 Pri (us)	Pulse 2 Pri (us)	Pulse 3 Pri (us)	Start Loc (us)	Start Burst Interval (us)	End Burst Interval (us)
1	256680	3	14	70	1093	1789	1248	576313	0	631578
2	472217	3	7	90	1487	1519	1387	837123	631579	1263157
3	1056408	2	15	60	1300	1235	0	1313733	1263158	1894736
4	438233	3	11	50	1640	1626	1561	2372676	1894737	2526315
5	874516	1	14	55	1877	0	0	2815736	2526316	3157894
6	348846	2	13	90	1863	1200	0	3692129	3157895	3789473
7	996866	2	8	50	1055	1132	0	4044038	3789474	4421052
8	610901	1	6	50	1793	0	0	5043091	4421053	5052631
9	449933	2	10	85	1193	1134	0	5655785	5052632	5684210
10	414854	2	6	55	1959	1429	0	6108045	5684211	6315789
11	946287	2	12	70	1585	1776	0	6526287	6315790	6947368
12	650731	1	7	50	1650	0	0	7475935	6947369	7578947
13	127864	3	5	95	1305	1346	1505	8128316	7578948	8210526
14	1011253	1	10	50	1576	0	0	8260335	8210527	8842105
15	601568	3	16	75	1859	1220	1014	9273164	8842106	9473684
16	524641	2	5	50	1143	1366	0	9878815	9473685	10105263
17	822834	2	5	70	1805	1464	0	10405965	10105264	10736842
18	149873	2	20	90	1565	1502	0	11232068	10736843	11368421
19		1	12	75	1019	0	0	11385008	11368422	12000000

Total number of pulses in waveform = 38

Type 5 Radar Waveform_27

```

Waveform Num = 27
Num of Bursts = 19
Burst Interval (us) = 631579

```

Burst #	Off Time (us)	# Pulses	Chirp (MHz)	PW (us)	Pulse 1 Pri (us)	Pulse 2 Pri (us)	Pulse 3 Pri (us)	Start Loc (us)	Start Burst Interval (us)	End Burst Interval (us)
1	638269	3	8	90	1695	1203	1158	179815	0	631578
2	670748	2	12	80	1612	1188	0	822140	631579	1263157
3	738602	2	7	95	1674	1396	0	1495688	1263158	1894736
4	653630	3	18	65	1978	1259	1333	2237360	1894737	2526315
5	850275	1	18	80	1091	0	0	2895660	2526316	3157894
6	416321	3	11	80	1322	1948	1860	3746926	3157895	3789473
7	780960	3	7	75	1502	1094	1914	4168377	3789474	4421052
8	456340	1	12	100	1108	0	0	4933847	4421053	5052631
9	297437	3	12	60	1561	1040	1465	5391295	5052632	5684210
10	1176795	2	16	80	1778	1760	0	5692798	5684211	6315789
11	327862	2	5	55	1844	1494	0	6873131	6315790	6947368
12	869186	3	19	75	1459	1686	1071	7204331	6947369	7578947
13	370525	3	10	90	1451	1738	1897	8077733	7578948	8210526
14	425907	2	10	90	1452	1874	0	8453344	8210527	8842105
15	597289	3	15	100	1783	1183	1423	8882577	8842106	9473684
16	1126385	3	18	95	1740	1065	1576	9484255	9473685	10105263
17	381722	2	16	65	1071	1081	0	10615022	10105264	10736842
18	636501	2	5	55	1843	1802	0	10995896	10736843	11368421
19		3	20	85	1243	1391	1154	11639042	11368422	12000000

Total number of pulses in waveform = 46

Type 5 Radar Waveform_28

```

Waveform Num = 28
Num of Bursts = 14
Burst Interval (us) = 857143

```

Burst #	Off Time (us)	# Pulses	Chirp (MHz)	PW (us)	Pulse 1 Pri (us)	Pulse 2 Pri (us)	Pulse 3 Pri (us)	Start Loc (us)	Start Burst Interval (us)	End Burst Interval (us)
1	657496	1	15	55	1690	0	0	657496	0	857142
2	525088	2	8	60	1402	1105	0	1184274	857143	1714285
3	1306531	3	10	55	1932	1620	1909	2493312	1714286	2571428
4	295378	2	14	85	1810	1044	0	2794151	2571429	3428571
5	693447	2	19	75	1972	1146	0	3490452	3428572	4285714
6	1004593	1	18	80	1611	0	0	4498163	4285715	5142857
7	834562	2	14	80	1547	1894	0	5334336	5142858	6000000
8	1319124	1	9	95	1040	0	0	6656901	6000001	6857143
9	444463	3	20	50	1977	1841	1734	7102404	6857144	7714286
10	691241	3	14	70	1517	1478	1111	7799197	7714287	8571429
11	1187064	1	18	65	1836	0	0	8990367	8571430	9428572
12	738827	2	18	65	1131	1807	0	9731030	9428573	10285715
13	1278070	2	16	60	1708	1589	0	11012038	10285716	11142858
14	858566	1	13	85	1331	0	0	11873901	11142859	12000001

Total number of pulses in waveform = 26



Type 5 Radar Waveform_29

Waveform Num = 29
Num of Bursts = 19
Burst Interval (us) = 631579

Burst #	Off Time (us)	# Pulses	Chirp (MHz)	PW (us)	Pulse 1 Pri (us)	Pulse 2 Pri (us)	Pulse 3 Pri (us)	Start Loc (us)	Start Burst Interval (us)	End Burst Interval (us)
1	505425	2	20	80	1438	1196	0	245395	0	631578
2	914644	2	6	70	1207	1470	0	753454	631579	1263157
3	517380	3	16	70	1511	1088	1125	1670775	1263158	1894736
4	676810	2	18	65	1917	1891	0	2191879	1894737	2526315
5	823127	3	5	85	1140	1056	1345	2872497	2526316	3157894
6	622876	1	11	80	1663	0	0	3699165	3157895	3789473
7	445435	2	11	95	1635	1521	0	4323704	3789474	4421052
8	807519	1	7	65	1594	0	0	4772295	4421053	5052631
9	188587	3	20	80	1492	1885	1773	5581408	5052632	5684210
10	688332	2	17	70	1896	1686	0	5775145	5684211	6315789
11	659293	3	18	65	1777	1337	1184	6467059	6315790	6947368
12	604898	3	6	80	1205	1114	1226	7140650	6947369	7578947
13	684900	3	14	80	1076	1047	1593	7749093	7578948	8210526
14	552678	1	13	70	1072	0	0	8437709	8210527	8842105
15	684998	3	20	90	1497	1789	1111	8991459	8842106	9473684
16	994548	2	20	65	1742	1729	0	9680854	9473685	10105263
17	674276	1	18	95	1896	0	0	10678873	10105264	10736842
18	456022	1	6	50	1716	0	0	11355045	10736843	11368421
19	456022	2	15	60	1989	1962	0	11812783	11368422	12000000

Total number of pulses in waveform = 40

Type 5 Radar Waveform_30

Waveform Num = 30
Num of Bursts = 17
Burst Interval (us) = 705882

Burst #	Off Time (us)	# Pulses	Chirp (MHz)	PW (us)	Pulse 1 Pri (us)	Pulse 2 Pri (us)	Pulse 3 Pri (us)	Start Loc (us)	Start Burst Interval (us)	End Burst Interval (us)
1	344310	1	13	80	1890	0	0	344310	0	705881
2	1046106	3	20	90	1701	1754	1301	1392306	705882	1411763
3	547251	3	10	60	1463	1065	1880	1944313	1411764	2117645
4	849462	2	10	60	1284	1414	0	2798183	2117646	2823527
5	716023	2	20	55	1825	1995	0	3516904	2823528	3529409
6	554336	3	20	55	1939	1960	1546	4075060	3529410	4235291
7	348481	1	13	50	1784	0	0	4428986	4235292	4941173
8	681045	3	14	95	1954	1494	1959	5111815	4941174	5647055
9	643396	2	14	60	1016	1001	0	5760618	5647056	6352937
10	744724	1	10	95	1409	0	0	6507359	6352938	7058819
11	702818	1	8	85	1338	0	0	7211586	7058820	7764701
12	1034222	1	11	85	1867	0	0	8247146	7764702	8470583
13	351591	2	11	90	1489	1277	0	8600604	8470584	9176465
14	649504	2	8	65	1660	1431	0	9252874	9176466	9882347
15	1234655	2	14	75	1862	1731	0	10490620	9882348	10588229
16	655516	1	9	60	1231	0	0	11149729	10588230	11294111
17	367106	2	13	85	1484	1232	0	11518066	11294112	11999993

Total number of pulses in waveform = 32

Radar Type 6 - Radar Statistical Performance

Trail #	Test Freq. (MHz)	1=Detection 0=No Detection	Trail #	Test Freq. (MHz)	1=Detection 0=No Detection
1	5311	1	16	5311	1
2	5311	1	17	5311	1
3	5311	1	18	5311	1
4	5311	1	19	5311	1
5	5311	1	20	5311	1
6	5311	1	21	5311	1
7	5311	1	22	5311	1
8	5311	1	23	5311	1
9	5311	1	24	5311	1
10	5311	1	25	5311	1
11	5311	1	26	5311	1
12	5311	1	27	5311	1
13	5311	1	28	5311	1
14	5311	1	29	5311	1
15	5311	1	30	5311	1
Detection Percentage (%)					100%

Radar waveform #1			Radar waveform #2		
Hopping Number	Frequency (MHz)	Pulse Start (ms)	Hopping Number	Frequency (MHz)	Pulse Start (ms)
5	5293	15	3	5310	9
9	5284	27	4	5292	12
19	5319	57	6	5289	18
23	5326	69	7	5318	21
43	5339	129	12	5338	36
46	5325	138	17	5324	51
64	5286	192	18	5307	54
73	5314	219	19	5305	57
77	5321	231	26	5303	78
82	5312	246	31	5332	93
87	5305	261	32	5300	96
88	5341	264	56	5301	168
89	5288	267	63	5284	189
97	5331	291	71	5335	213
98	5330	294	81	5308	243
--	--	--	83	5336	249

Radar waveform #3			Radar waveform #4		
Hopping Number	Frequency (MHz)	Pulse Start (ms)	Hopping Number	Frequency (MHz)	Pulse Start (ms)
2	5285	6	9	5303	27
5	5289	15	10	5330	30
12	5296	36	31	5324	93
13	5303	39	32	5323	96
15	5298	45	47	6334	141
17	5316	51	52	5326	156
43	5324	129	59	5337	177
47	5300	141	62	5316	186
48	5291	144	64	5288	192
50	5332	150	66	5297	198
60	5287	180	68	5310	204
67	5322	201	74	5319	222
72	5313	216	77	5332	231
81	5336	243	--	--	--
85	5312	255	--	--	--
90	5340	270	--	--	--
96	5334	288	--	--	--

Radar waveform #5			Radar waveform #6		
Hopping Number	Frequency (MHz)	Pulse Start (ms)	Hopping Number	Frequency (MHz)	Pulse Start (ms)
0	5331	0	10	5336	30
21	5332	63	12	5297	36
23	5284	69	13	5328	39
34	5294	102	29	5305	87
58	5314	174	38	5302	114
79	5311	237	45	5290	135
83	5338	249	47	5333	141
84	5318	252	54	5319	162
96	5317	288	61	5324	183
98	5336	294	68	5288	204
--	--	--	80	5309	240
--	--	--	83	5322	249
--	--	--	85	5312	255
--	--	--	95	5311	285

Radar waveform #7			Radar waveform #8		
Hopping Number	Frequency (MHz)	Pulse Start (ms)	Hopping Number	Frequency (MHz)	Pulse Start (ms)
12	5336	36	13	5310	39
13	5285	39	14	5325	42
27	5300	81	24	5340	72
28	5287	84	37	5319	111
31	5302	93	40	5300	120
37	5322	111	49	5301	147
40	5332	120	51	5335	153
43	5329	129	66	5305	198
48	5321	144	72	5334	216
49	5318	147	74	5294	222
52	5339	156	91	5333	273
57	5301	171	--	--	--
60	5326	180	--	--	--
71	5292	213	--	--	--
76	5331	228	--	--	--
81	5304	243	--	--	--
83	5315	249	--	--	--
97	5323	291	--	--	--

Radar waveform #9			Radar waveform #10		
Hopping Number	Frequency (MHz)	Pulse Start (ms)	Hopping Number	Frequency (MHz)	Pulse Start (ms)
3	5341	9	3	5326	9
6	5318	18	5	5293	15
14	5302	42	13	5310	39
16	5320	48	28	5289	84
18	5321	54	29	5325	87
27	5325	81	31	5321	93
32	5291	96	34	5281	102
43	5311	129	48	5318	144
47	5338	141	58	5329	174
53	5294	159	60	5306	180
73	5332	219	62	5320	186
80	5284	240	67	5300	201
85	5309	255	78	5287	234
89	5282	267	82	5284	246
--	--	--	89	5333	267

Radar waveform #11			Radar waveform #12		
Hopping Number	Frequency (MHz)	Pulse Start (ms)	Hopping Number	Frequency (MHz)	Pulse Start (ms)
9	5281	27	0	5295	0
42	5309	126	6	5311	18
54	5321	162	15	5327	45
58	5328	174	36	5338	108
84	5292	252	46	5306	138
88	5315	264	51	5299	153
92	5305	276	56	5287	168
96	5283	288	57	5326	171
--	--	--	62	5330	186
--	--	--	68	5288	204
--	--	--	70	5290	210

Radar waveform #13			Radar waveform #14		
Hopping Number	Frequency (MHz)	Pulse Start (ms)	Hopping Number	Frequency (MHz)	Pulse Start (ms)
2	5289	6	1	5311	3
5	5338	15	5	5319	15
7	5285	21	13	5307	39
10	5340	30	22	5333	66
13	5286	39	23	5295	69
14	5297	42	25	5308	75
17	5329	51	26	5300	78
21	5339	63	27	5304	81
23	5333	69	38	5341	114
37	5324	111	39	5306	117
38	5328	114	51	5327	153
46	5304	138	56	5330	168
47	5310	141	84	5294	252
59	5281	177	85	5303	255
61	5325	183	--	--	--
65	5336	195	--	--	--
70	5295	210	--	--	--
83	5292	249	--	--	--

Radar waveform #15			Radar waveform #16		
Hopping Number	Frequency (MHz)	Pulse Start (ms)	Hopping Number	Frequency (MHz)	Pulse Start (ms)
0	5294	0	15	5328	45
3	5321	9	19	5314	57
18	5319	54	24	5299	72
20	5316	60	27	5340	81
27	5338	81	43	5334	129
40	5325	120	45	5303	135
62	5308	186	48	5282	144
77	5289	231	53	5284	159
94	5337	282	62	5335	186
96	5330	288	69	5289	207
--	--	--	71	5310	213
--	--	--	94	5317	282

Radar waveform #17			Radar waveform #18		
Hopping Number	Frequency (MHz)	Pulse Start (ms)	Hopping Number	Frequency (MHz)	Pulse Start (ms)
1	5302	3	6	5328	18
17	5308	51	9	5286	27
19	5318	57	36	5332	108
25	5323	75	45	5331	135
47	5298	141	54	5321	162
52	5327	156	58	5308	174
55	5326	165	63	5341	189
74	5335	222	75	5335	225
82	5320	246	77	5322	231
83	5290	249	85	5300	255
84	5295	252	86	5299	258
--	--	--	91	5284	273
--	--	--	97	514	291

Radar waveform #19			Radar waveform #20		
Hopping Number	Frequency (MHz)	Pulse Start (ms)	Hopping Number	Frequency (MHz)	Pulse Start (ms)
22	5311	66	5	5309	15
50	5321	150	12	5304	36
53	5288	159	13	5305	39
60	5330	180	25	5281	75
63	5289	189	31	5329	93
70	5315	210	37	5283	111
71	5294	213	40	5287	120
72	5329	216	51	5296	153
83	5316	249	58	5316	174
85	5303	255	63	5335	189
90	5309	270	77	5298	231
--	--	--	91	5303	273
--	--	--	99	5300	297

Radar waveform #21			Radar waveform #22		
Hopping Number	Frequency (MHz)	Pulse Start (ms)	Hopping Number	Frequency (MHz)	Pulse Start (ms)
2	5281	6	3	5288	9
6	5322	18	9	5331	27
10	5336	30	16	5300	48
34	5304	102	39	5324	117
38	5305	114	77	5302	231
56	5300	168	86	5316	258
57	5307	171	88	5335	264
68	5312	204	89	5328	267
78	5313	234	94	5315	282
89	5310	267	--	--	--
91	5293	273	--	--	--
97	5283	291	--	--	--
99	5340	297	--	--	--

Radar waveform #23			Radar waveform #24		
Hopping Number	Frequency (MHz)	Pulse Start (ms)	Hopping Number	Frequency (MHz)	Pulse Start (ms)
2	5302	6	5	5335	15
5	5296	15	15	5290	45
12	5341	36	24	5289	72
19	5291	57	34	5306	102
20	5281	60	37	5326	111
21	5327	63	44	5291	132
22	5310	66	48	5339	144
35	5314	105	53	5292	159
48	5331	144	65	5336	195
51	5285	153	70	5337	210
52	5313	156	89	5300	267
63	5338	189	90	5333	270
72	5301	216	91	5327	273
93	5290	279	92	5330	276
--	--	--	93	5334	279

Radar waveform #25			Radar waveform #26		
Hopping Number	Frequency (MHz)	Pulse Start (ms)	Hopping Number	Frequency (MHz)	Pulse Start (ms)
4	5291	12	19	5338	57
7	5283	21	27	5299	81
11	5319	33	30	5281	90
21	5336	63	35	5332	105
23	5309	69	42	5306	126
29	5312	87	46	5286	138
35	5296	105	47	5297	141
50	5315	150	48	5335	144
57	5294	171	67	5305	201
75	5292	225	72	5301	216
85	5340	255	83	5296	249
95	5331	285	89	5324	267
99	5317	297	--	--	--

Radar waveform #27			Radar waveform #28		
Hopping Number	Frequency (MHz)	Pulse Start (ms)	Hopping Number	Frequency (MHz)	Pulse Start (ms)
13	5313	39	15	5285	45
16	5338	48	20	5305	60
20	5299	60	32	5322	96
35	5283	105	37	5290	111
39	5333	117	44	5332	132
40	5305	120	50	5330	150
54	5282	162	60	5296	180
63	5291	189	70	5314	210
70	5306	210	74	5303	222
72	5320	216	79	5338	237
92	5331	276	83	5336	249
97	5286	291	84	5329	252
--	--	--	86	5299	258
--	--	--	92	5326	276

Radar waveform #29			Radar waveform #30		
Hopping Number	Frequency (MHz)	Pulse Start (ms)	Hopping Number	Frequency (MHz)	Pulse Start (ms)
2	5309	6	7	5339	21
7	5310	21	14	5309	42
19	5311	57	18	5308	54
22	5283	66	20	5338	60
30	5286	90	28	5329	84
57	5301	171	35	5328	105
59	5340	177	56	5302	168
60	5294	180	59	5304	177
61	5334	183	75	5312	225
63	5298	189	81	5330	243
--	--	--	85	5323	255
--	--	--	92	5333	276
--	--	--	95	5299	285

Radar Statistical Performance for 802.11ac-VHT80

Radar Type 1 - Radar Statistical Performance

Trail #	Test Freq. (MHz)	Pulse Width (us)	PRI (us)	Pulses / Burst	1=Detection 0=No Detection
1	5491	1	618	86	1
2	5491	1	938	57	1
3	5491	1	818	65	1
4	5491	1	878	61	1
5	5491	1	538	99	1
6	5491	1	558	95	1
7	5491	1	698	76	1
8	5491	1	598	89	1
9	5491	1	858	62	1
10	5491	1	778	68	1
11	5491	1	658	81	1
12	5491	1	578	92	1
13	5491	1	718	74	1
14	5491	1	798	67	1
15	5491	1	918	58	1
16	5491	1	2189	25	1
17	5491	1	3042	18	1
18	5491	1	1025	52	1
19	5491	1	3060	18	1
20	5491	1	779	68	1
21	5491	1	1004	53	1
22	5491	1	1292	41	1
23	5491	1	2133	25	1
24	5491	1	2160	25	1
25	5491	1	688	77	1
26	5491	1	2495	22	1
27	5491	1	983	54	1
28	5491	1	1533	35	1
29	5491	1	2910	19	1
30	5491	1	2102	26	1
Detection Percentage (%)					100%

Radar Type 2 - Radar Statistical Performance

Trail #	Test Freq. (MHz)	Pulse Width (us)	PRI (us)	Pulses / Burst	1=Detection 0=No Detection
1	5509	3.6	222	24	1
2	5509	3.0	197	23	1
3	5509	4.5	193	29	1
4	5509	3.2	225	25	1
5	5509	1.7	190	27	1
6	5509	1.7	167	28	1
7	5509	3.1	165	27	1
8	5509	4.3	168	29	1
9	5509	1.4	184	26	1
10	5509	2.7	197	25	1
11	5509	2.0	193	26	1
12	5509	1.8	173	29	1
13	5509	2.9	179	24	1
14	5509	1.5	193	29	1
15	5509	3.8	193	27	1
16	5509	1.1	191	28	1
17	5509	4.9	192	28	1
18	5509	2.1	211	23	1
19	5509	4.9	222	29	1
20	5509	3.1	161	26	1
21	5509	3.6	159	27	1
22	5509	4.8	188	26	1
23	5509	3.6	176	29	1
24	5509	1.3	154	27	1
25	5509	1.9	218	28	1
26	5509	4.7	196	29	1
27	5509	4.3	150	29	1
28	5509	2.7	165	26	1
29	5509	1.0	217	28	1
30	5509	3.3	204	23	1
Detection Percentage (%)					100%

Radar Type 3 - Radar Statistical Performance

Trail #	Test Freq. (MHz)	Pulse Width (us)	PRI (us)	Pulses / Burst	1=Detection 0=No Detection
1	5530	7.5	321	16	1
2	5530	9.2	357	17	1
3	5530	6.3	479	17	1
4	5530	9.9	335	16	1
5	5530	7.5	366	16	1
6	5530	9.5	285	16	1
7	5530	8.7	467	17	1
8	5530	7.7	273	16	1
9	5530	8.7	255	18	1
10	5530	10.0	289	16	1
11	5530	9.8	380	16	1
12	5530	6.1	383	18	1
13	5530	8.5	255	18	1
14	5530	6.7	278	17	1
15	5530	7.4	267	18	1
16	5530	7.0	314	17	1
17	5530	6.2	354	16	1
18	5530	7.1	458	18	1
19	5530	8.0	270	16	1
20	5530	7.7	341	18	1
21	5530	7.7	351	18	1
22	5530	6.3	419	17	1
23	5530	6.4	484	16	1
24	5530	9.9	410	16	1
25	5530	7.2	344	18	1
26	5530	8.9	430	16	1
27	5530	9.1	370	18	1
28	5530	8.9	344	17	1
29	5530	6.7	268	16	1
30	5530	7.1	258	18	1
Detection Percentage (%)					100%

Radar Type 4 - Radar Statistical Performance

Trail #	Test Freq. (MHz)	Pulse Width (us)	PRI (us)	Pulses / Burst	1=Detection 0=No Detection
1	5545	13.9	15	15	1
2	5545	15.0	13	13	1
3	5545	17.7	12	12	1
4	5545	16.2	15	15	1
5	5545	16.3	12	12	1
6	5545	11.9	12	12	1
7	5545	17.0	13	13	1
8	5545	14.9	12	12	1
9	5545	14.4	15	15	1
10	5545	12.8	15	15	1
11	5545	12.0	13	13	1
12	5545	11.1	12	12	1
13	5545	18.8	14	14	1
14	5545	15.4	12	12	1
15	5545	18.3	15	15	1
16	5545	12.9	12	12	1
17	5545	19.2	16	16	1
18	5545	18.7	14	14	1
19	5545	19.2	12	12	1
20	5545	14.0	14	14	1
21	5545	15.0	16	16	1
22	5545	12.3	12	12	1
23	5545	16.6	16	16	1
24	5545	17.7	16	16	1
25	5545	12.2	15	15	1
26	5545	11.3	15	15	1
27	5545	15.2	14	14	1
28	5545	11.1	16	16	1
29	5545	19.3	12	12	1
30	5545	19.2	12	12	1
Detection Percentage (%)					100%

Note: In addition an average minimum percentage of successful detection across all four Short pulse radar test

waveforms is as follows: $\frac{P_d1 + P_d2 + P_d3 + P_d4}{4} = (100\% + 100\% + 100\% + 100\%) / 4 = 100\% (>80\%)$



Radar Type 5 - Radar Statistical Performance

Trail #	Test Freq. (MHz)	1=Detection 0=No Detection	Trail #	Test Freq. (MHz)	1=Detection 0=No Detection
1	5551	1	16	5551	1
2	5551	1	17	5551	1
3	5551	1	18	5551	1
4	5551	1	19	5551	1
5	5551	1	20	5551	1
6	5551	1	21	5551	1
7	5551	1	22	5551	1
8	5551	1	23	5551	1
9	5551	1	24	5551	1
10	5551	1	25	5551	1
11	5551	1	26	5551	1
12	5551	1	27	5551	1
13	5551	1	28	5551	1
14	5551	1	29	5551	1
15	5551	1	30	5551	1
Detection Percentage (%)					100%

Type 5 Radar Waveform_1										
Waveform Num = 1										
Num of Bursts = 10										
Burst Interval (us)= 1200000										
Burst #	Off Time (us)	# Pulses	Chirp (MHz)	PW (us)	Pulse 1 Pri(us)	Pulse 2 Pri(us)	Pulse 3 Pri(us)	Start Loc (us)	Start Burst Interval(us)	End Burst Interval(us)
1	646150	2	10	75	1959	1755	0	646150	0	1199999
2	1513018	3	11	50	1047	1274	1498	2162882	1200000	2399999
3	1182604	3	18	95	1692	1228	1036	3349305	2400000	3599999
4	383044	2	14	75	1254	1089	0	3736305	3600000	4799999
5	1955283	2	16	60	1407	1901	0	5693931	4800000	5999999
6	786953	3	8	100	1079	1532	1781	6484192	6000000	7199999
7	900075	3	8	100	1445	1164	1259	7388659	7200000	8399999
8	1587436	1	17	95	1997	0	0	8979963	8400000	9599999
9	1691130	1	8	80	1366	0	0	10673090	9600000	10799999
10	331089	2	18	50	1853	1892	0	11005545	10800000	11999999
Total number of pulses in waveform = 22										



Type 5 Radar Waveform_2

Waveform Num = 2
Num of Bursts = 12
Burst Interval (us)= 1000000

Burst #	Off Time (us)	# Pulses	Chirp (MHz)	PW (us)	Pulse 1 Pri(us)	Pulse 2 Pri(us)	Pulse 3 Pri(us)	Start Loc (us)	Start Burst Interval(us)	End Burst Interval(us)
1	662240	2	8	60	1604	1443	0	662240	0	999999
2	773181	3	14	70	1418	1707	1127	1438468	1000000	1999999
3	1169863	2	12	80	1528	1345	0	2612583	2000000	2999999
4	742630	3	13	50	1488	1256	1390	3358086	3000000	3999999
5	1435757	1	8	85	1024	0	0	4797977	4000000	4999999
6	1087403	2	11	90	1357	1828	0	5886404	5000000	5999999
7	772786	3	19	95	1184	1157	1341	6662375	6000000	6999999
8	506682	2	8	65	1455	1039	0	7172739	7000000	7999999
9	1150752	1	17	100	1197	0	0	8325985	8000000	8999999
10	1437778	1	12	90	1120	0	0	9764960	9000000	9999999
11	764335	3	5	55	1702	1749	1695	10530415	10000000	10999999
12	604802	1	8	95	1470	0	0	11140363	11000000	11999999

Total number of pulses in waveform = 24

Type 5 Radar Waveform_3

Waveform Num = 3
Num of Bursts = 12
Burst Interval (us)= 1000000

Burst #	Off Time (us)	# Pulses	Chirp (MHz)	PW (us)	Pulse 1 Pri(us)	Pulse 2 Pri(us)	Pulse 3 Pri(us)	Start Loc (us)	Start Burst Interval(us)	End Burst Interval(us)
1	422544	1	12	60	1972	0	0	422544	0	999999
2	884505	3	6	50	1439	1492	1721	1309021	1000000	1999999
3	1065027	2	12	65	1894	1587	0	2378700	2000000	2999999
4	1104132	2	17	85	1502	1469	0	3486313	3000000	3999999
5	1101513	2	19	95	1363	1473	0	4590797	4000000	4999999
6	789279	1	13	50	1733	0	0	5382912	5000000	5999999
7	1365257	3	17	75	1502	1527	1825	6749902	6000000	6999999
8	532576	3	7	85	1444	1379	1050	7287332	7000000	7999999
9	1175368	3	5	90	1787	1869	1088	8466573	8000000	8999999
10	807953	3	18	75	1303	1043	1701	9279270	9000000	9999999
11	911547	1	13	100	1019	0	0	10194864	10000000	10999999
12	974288	3	20	70	1880	1878	1260	11170171	11000000	11999999

Total number of pulses in waveform = 27

Type 5 Radar Waveform_4

Waveform Num = 4
Num of Bursts = 8
Burst Interval (us)= 1500000

Burst #	Off Time (us)	# Pulses	Chirp (MHz)	PW (us)	Pulse 1 Pri(us)	Pulse 2 Pri(us)	Pulse 3 Pri(us)	Start Loc (us)	Start Burst Interval(us)	End Burst Interval(us)
1	370679	2	9	70	1468	1414	0	370679	0	1499999
2	2179207	3	18	50	1416	1246	1597	2552768	1500000	2999999
3	765677	3	8	60	1678	1763	1206	3322704	3000000	4499999
4	1589772	3	19	55	1876	1029	1139	4917123	4500000	5999999
5	2521924	3	15	70	1933	1423	1820	7443091	6000000	7499999
6	625953	3	11	65	1411	1493	1906	8074220	7500000	8999999
7	1416903	3	13	55	2000	1002	1619	9495933	9000000	10499999
8	1137478	1	13	100	1902	0	0	10638032	10500000	11999999

Total number of pulses in waveform = 21



Type 5 Radar Waveform_5

Waveform Num = 5
Num of Bursts = 11
Burst Interval (us)= 1090909

Burst #	Off Time (us)	# Pulses	Chirp (MHz)	PW (us)	Pulse 1 Pri (us)	Pulse 2 Pri (us)	Pulse 3 Pri (us)	Start Loc (us)	Start Burst Interval (us)	End Burst Interval (us)
1	132701	2	19	100	1580	1412	0	132701	0	1090908
2	1783092	1	20	60	1027	0	0	1918785	1090909	2181817
3	497515	3	16	55	1097	1451	1549	2417327	2181818	3272726
4	898440	1	7	65	1386	0	0	3319864	3272727	4363635
5	2088470	3	20	90	1249	1240	1198	5409720	4363636	5454544
6	185007	2	14	70	1471	1637	0	5588414	5454545	6545453
7	1487025	3	13	90	1371	1782	1036	7088547	6545454	7636362
8	1094372	2	7	100	1745	1987	0	8187108	7636363	8727271
9	741952	2	17	80	1814	1833	0	8932792	8727272	9818180
10	1950627	3	5	70	1626	1932	1658	10887066	9818181	10909089
11	812520	1	5	70	1008	0	0	11704802	10909090	11999998

Total number of pulses in waveform = 23

Type 5 Radar Waveform_6

Waveform Num = 6
Num of Bursts = 17
Burst Interval (us)= 705882

Burst #	Off Time (us)	# Pulses	Chirp (MHz)	PW (us)	Pulse 1 Pri (us)	Pulse 2 Pri (us)	Pulse 3 Pri (us)	Start Loc (us)	Start Burst Interval (us)	End Burst Interval (us)
1	327620	1	7	70	1597	0	0	327620	0	705881
2	499147	3	7	85	1591	1903	1274	828364	705882	1411763
3	1018181	2	9	95	1042	1969	0	1851313	1411764	2117645
4	560792	1	14	80	1806	0	0	2415116	2117646	2823527
5	626018	3	14	70	1843	1927	1986	3042940	2823528	3529409
6	786644	2	10	90	1159	1767	0	3815340	3529410	4235291
7	1039623	1	15	55	1024	0	0	4857889	4235292	4941173
8	562093	3	9	60	1584	1203	1779	5421006	4941174	5647055
9	892397	1	6	85	1800	0	0	6317969	5647056	6352937
10	683914	1	9	85	1419	0	0	7003683	6352938	7058819
11	504410	3	12	100	1226	1971	1334	7509512	7058820	7764701
12	747623	3	20	95	1312	1098	1349	8261666	7764702	8470583
13	827511	2	5	80	1492	1042	0	9092936	8470584	9176465
14	117552	2	18	65	1599	1332	0	9213022	9176466	9882347
15	1101451	1	15	95	1348	0	0	10317404	9882348	10588229
16	483036	2	14	60	1817	1934	0	10801788	10588230	11294111
17	626645	3	18	50	1478	1856	1194	11432184	11294112	11999993

Total number of pulses in waveform = 34

Type 5 Radar Waveform_7

Waveform Num = 7
Num of Bursts = 19
Burst Interval (us)= 631579

Burst #	Off Time (us)	# Pulses	Chirp (MHz)	PW (us)	Pulse 1 Pri (us)	Pulse 2 Pri (us)	Pulse 3 Pri (us)	Start Loc (us)	Start Burst Interval (us)	End Burst Interval (us)
1	198433	2	8	70	1684	1443	0	198433	0	631578
2	637644	3	10	55	1574	1886	1024	839204	631579	1263157
3	551196	2	13	90	1493	1278	0	1394884	1263158	1894736
4	906165	1	14	65	1074	0	0	2303810	1894737	2526315
5	741706	2	17	80	1089	1500	0	3046590	2526316	3157894
6	549741	2	15	60	1692	1513	0	3589920	3157895	3789473
7	714621	1	6	95	1092	0	0	4316746	3789474	4421052
8	451112	2	6	55	1863	1468	0	4768950	4421053	5052631
9	743838	1	18	100	1728	0	0	5516109	5052632	5684210
10	451526	3	15	90	1381	1667	1543	5969363	5684211	6315789
11	929989	3	5	75	1753	1502	1905	6903843	6315790	6947368
12	355581	2	9	70	1357	1923	0	7264584	6947369	7578947
13	832926	3	15	100	1475	1812	1488	8100790	7578948	8210526
14	630492	2	5	80	1913	1483	0	8736057	8210527	8842105
15	208595	3	12	85	1996	1105	1232	8948048	8842106	9473684
16	600130	2	5	85	1265	1061	0	9552511	9473685	10105263
17	1108063	1	17	50	1723	0	0	10660900	10105264	10736842
18	677562	2	13	60	1038	1522	0	11340185	10736843	11368421
19	120854	1	11	90	1235	0	0	11463599	11368422	12000000

Total number of pulses in waveform = 38



Type 5 Radar Waveform_8

Waveform Num = 8
Num of Bursts = 13
Burst Interval (us)= 923077

Burst #	Off Time (us)	# Pulses	Chirp (MHz)	PW (us)	Pulse 1 Pri (us)	Pulse 2 Pri (us)	Pulse 3 Pri (us)	Start Loc (us)	Start Burst Interval (us)	End Burst Interval (us)
1	118227	2	17	55	1144	1461	0	118227	0	923076
2	1324669	2	19	95	1938	1177	0	1445501	923077	1846153
3	904839	3	6	80	1877	1288	1325	2383455	1846154	2769230
4	1201721	1	8	95	1534	0	0	3589666	2769231	3692307
5	685597	2	9	90	1975	1881	0	4276797	3692308	4615384
6	1012712	1	17	60	1942	0	0	5293365	4615385	5538461
7	1024538	3	14	85	1089	1986	1788	6319845	5538462	6461538
8	385574	2	17	55	1905	1317	0	6710282	6461539	7384615
9	843097	2	10	70	1279	1082	0	7556601	7384616	8307692
10	856105	2	5	85	1034	1106	0	8415067	8307693	9230769
11	1709675	1	5	85	1850	0	0	10126882	9230770	10153846
12	454704	2	14	85	1475	1105	0	10583436	10153847	11076923
13	821902	1	19	70	1994	0	0	11407918	11076924	12000000

Total number of pulses in waveform = 24

Type 5 Radar Waveform_9

Waveform Num = 9
Num of Bursts = 9
Burst Interval (us)= 1333333

Burst #	Off Time (us)	# Pulses	Chirp (MHz)	PW (us)	Pulse 1 Pri (us)	Pulse 2 Pri (us)	Pulse 3 Pri (us)	Start Loc (us)	Start Burst Interval (us)	End Burst Interval (us)
1	315767	3	9	85	1068	1176	1458	315767	0	1333332
2	1906649	3	17	60	1437	1114	1821	2226118	1333333	2666665
3	1710381	2	18	100	1776	1011	0	3940871	2666666	3999998
4	1209620	1	20	100	1762	0	0	5153278	3999999	5333331
5	1429608	1	5	60	1617	0	0	6584648	5333332	6666664
6	1217289	3	5	75	1411	1397	1919	7803554	6666665	7999997
7	1459957	3	12	95	1907	1348	1569	9268238	7999998	9333330
8	1028008	2	12	95	1413	1739	0	10301070	9333331	10666663
9	1002553	1	15	70	1853	0	0	11306775	10666664	11999996

Total number of pulses in waveform = 19

Type 5 Radar Waveform_10

Waveform Num = 10
Num of Bursts = 8
Burst Interval (us)= 1500000

Burst #	Off Time (us)	# Pulses	Chirp (MHz)	PW (us)	Pulse 1 Pri (us)	Pulse 2 Pri (us)	Pulse 3 Pri (us)	Start Loc (us)	Start Burst Interval (us)	End Burst Interval (us)
1	1156078	3	15	60	1822	1152	1320	1156078	0	1499999
2	1227908	1	10	90	1517	0	0	2388280	1500000	2999999
3	1723227	3	11	80	1250	1618	1418	4113024	3000000	4499999
4	983103	1	6	80	1669	0	0	5100413	4500000	5999999
5	1889615	1	15	100	1227	0	0	6991697	6000000	7499999
6	1133410	1	19	85	1812	0	0	8126334	7500000	8999999
7	1052020	1	16	60	1202	0	0	9180166	9000000	10499999
8	1803603	1	10	100	1748	0	0	10884971	10500000	11999999

Total number of pulses in waveform = 12



Type 5 Radar Waveform_11

Waveform Num = 11
Num of Bursts = 14
Burst Interval (us) = 857143

Burst #	Off Time (us)	# Pulses	Chirp (MHz)	PW (us)	Pulse 1 Pri (us)	Pulse 2 Pri (us)	Pulse 3 Pri (us)	Start Loc (us)	Start Burst Interval (us)	End Burst Interval (us)
1	101672	3	20	90	1866	1585	1521	101672	0	857142
2	1599428	1	10	90	1080	0	0	1706072	857143	1714285
3	737511	1	7	60	1207	0	0	2444663	1714286	2571428
4	926426	2	6	65	1378	1527	0	3372296	2571429	3428571
5	323469	1	16	100	1516	0	0	3698670	3428572	4285714
6	1341503	2	11	75	1534	1813	0	5041689	4285715	5142857
7	790339	2	11	55	1264	1876	0	5835375	5142858	6000000
8	738506	3	12	100	1749	1969	1769	6577021	6000001	6857143
9	528772	3	9	55	1540	1429	1943	7111280	6857144	7714286
10	1199583	1	10	70	1364	0	0	8315775	7714287	8571429
11	420017	1	10	70	1313	0	0	8737156	8571430	9428572
12	905136	1	19	65	1874	0	0	9643605	9428573	10285715
13	1008607	2	14	50	1349	1697	0	10654086	10285716	11142858
14	1279397	3	20	95	1039	1221	1440	11936529	11142859	12000001

Total number of pulses in waveform = 26

Type 5 Radar Waveform_12

Waveform Num = 12
Num of Bursts = 18
Burst Interval (us) = 666667

Burst #	Off Time (us)	# Pulses	Chirp (MHz)	PW (us)	Pulse 1 Pri (us)	Pulse 2 Pri (us)	Pulse 3 Pri (us)	Start Loc (us)	Start Burst Interval (us)	End Burst Interval (us)
1	360079	2	17	55	1028	1305	0	360079	0	666666
2	841450	1	12	65	1994	0	0	1203862	666667	1333333
3	686891	1	11	95	1989	0	0	1892747	1333334	2000000
4	615486	1	10	75	1142	0	0	2510222	2000001	2666667
5	769761	3	15	50	1429	1728	1088	3281125	2666668	3333334
6	575083	2	9	85	1874	1120	0	3860453	3333335	4000001
7	251242	3	14	65	1392	1513	1151	4114689	4000002	4666668
8	707089	2	18	70	1414	1600	0	4825814	4666669	5333335
9	783502	2	13	75	1210	1855	0	5612330	5333336	6000002
10	779916	2	17	65	1675	1775	0	6395311	6000003	6666669
11	418086	2	18	95	1519	1216	0	6816847	6666670	7333336
12	538566	1	10	90	1558	0	0	7358148	7333337	8000003
13	740584	3	12	65	1378	1957	1863	8100290	8000004	8666670
14	1004534	2	12	60	1274	1448	0	9110022	8666671	9333337
15	778672	2	14	85	1278	1725	0	9891416	9333338	10000004
16	701888	1	19	95	1754	0	0	10596307	10000005	10666671
17	167123	2	17	100	1754	1762	0	10765184	10666672	11333338
18	961734	3	7	50	1398	1076	1839	11730434	11333339	12000005

Total number of pulses in waveform = 35

Type 5 Radar Waveform_13

Waveform Num = 13
Num of Bursts = 20
Burst Interval (us) = 600000

Burst #	Off Time (us)	# Pulses	Chirp (MHz)	PW (us)	Pulse 1 Pri (us)	Pulse 2 Pri (us)	Pulse 3 Pri (us)	Start Loc (us)	Start Burst Interval (us)	End Burst Interval (us)
1	325488	1	16	60	1600	0	0	325488	0	599999
2	546541	3	14	65	1854	1483	1492	873629	600000	1199999
3	494576	2	16	75	1501	1222	0	1373034	1200000	1799999
4	529469	3	15	80	1398	1713	1642	1905226	1800000	2399999
5	690228	3	16	65	1224	1412	1827	2600207	2400000	2999999
6	474766	2	7	50	1152	1646	0	3079436	3000000	3599999
7	991521	1	5	60	1673	0	0	4073755	3600000	4199999
8	703685	3	18	60	1409	1646	1391	4779013	4200000	4799999
9	420812	1	8	95	1065	0	0	5204271	4800000	5399999
10	418271	3	7	95	1618	1641	1289	5623607	5400000	5999999
11	629736	2	18	85	1478	1754	0	6257891	6000000	6599999
12	526857	3	14	100	1638	1281	1204	6787980	6600000	7199999
13	789904	1	16	70	1427	0	0	7582007	7200000	7799999
14	394687	1	17	70	1471	0	0	7978121	7800000	8399999
15	578686	2	5	55	1185	1022	0	8568278	8400000	8999999
16	575184	3	13	55	1997	1924	1432	9135669	9000000	9599999
17	638683	1	10	65	1244	0	0	9779705	9600000	10199999
18	633979	2	16	90	1094	1581	0	10414928	10200000	10799999
19	728966	2	6	95	1630	1387	0	11146569	10800000	11399999
20	816925	1	8	70	1306	0	0	11966511	11400000	11999999

Total number of pulses in waveform = 40



Type 5 Radar Waveform_14

Waveform Num = 14
Num of Bursts = 17
Burst Interval (us) = 705882

Burst #	Off Time (us)	# Pulses	Chirp (MHz)	PW (us)	Pulse 1 Pri (us)	Pulse 2 Pri (us)	Pulse 3 Pri (us)	Start Loc (us)	Start Burst Interval (us)	End Burst Interval (us)
1	209709	2	9	70	1718	1593	0	209709	0	705881
2	1021087	3	20	65	1725	1866	1472	1234107	705882	1411763
3	830597	1	11	70	1223	0	0	2069767	1411764	2117645
4	266507	1	11	100	1464	0	0	2337497	2117646	2823527
5	649014	3	20	85	1449	1573	1905	2987975	2823528	3529409
6	794314	3	14	75	1627	1104	1429	3787216	3529410	4235291
7	456263	1	8	75	1342	0	0	4247639	4235292	4941173
8	1219701	1	15	50	1104	0	0	5468682	4941174	5647055
9	431387	1	18	100	1441	0	0	5901173	5647056	6352937
10	1126164	3	14	85	1282	1996	1055	7028778	6352938	7058819
11	606452	3	8	60	1099	1822	1808	7639563	7058820	7764701
12	795272	2	7	70	1695	1288	0	8439564	7764702	8470583
13	422062	3	9	80	1974	1942	1412	8664609	8470584	9176465
14	890825	2	11	65	1944	1927	0	9760762	9176466	9882347
15	530751	3	14	75	1763	1434	1783	10295384	9882348	10588229
16	698006	3	16	100	1219	1867	1895	10998370	10588230	11294111
17	391226	1	18	55	1554	0	0	11394577	11294112	11999993

Total number of pulses in waveform = 86

Type 5 Radar Waveform_15

Waveform Num = 15
Num of Bursts = 14
Burst Interval (us) = 857143

Burst #	Off Time (us)	# Pulses	Chirp (MHz)	PW (us)	Pulse 1 Pri (us)	Pulse 2 Pri (us)	Pulse 3 Pri (us)	Start Loc (us)	Start Burst Interval (us)	End Burst Interval (us)
1	146312	1	19	75	1222	0	0	146312	0	857142
2	1465427	2	5	50	1349	1278	0	1612961	857143	1714285
3	104268	1	20	85	1097	0	0	1719856	1714286	2571428
4	1030196	2	9	80	1201	1246	0	2751149	2571429	3428571
5	1451823	3	20	80	1460	1593	1177	4205419	3428572	4285714
6	348595	3	6	50	1292	1938	1937	4588244	4285715	5142857
7	587526	2	18	65	1426	1820	0	5150937	5142858	6000000
8	994276	1	8	85	1152	0	0	6148459	6000001	6857143
9	805344	3	16	80	1287	1222	1899	6954955	6857144	7714286
10	1570776	2	14	70	1790	1303	0	8530139	7714287	8571429
11	620535	3	9	75	1304	1873	1275	9153767	8571430	9428572
12	1047405	3	18	55	1903	1995	1983	10205624	9428573	10285715
13	419638	2	11	75	1520	1675	0	10631143	10285716	11142858
14	1288991	1	8	70	1205	0	0	11923329	11142859	12000001

Total number of pulses in waveform = 29

Type 5 Radar Waveform_16

Waveform Num = 16
Num of Bursts = 13
Burst Interval (us) = 923077

Burst #	Off Time (us)	# Pulses	Chirp (MHz)	PW (us)	Pulse 1 Pri (us)	Pulse 2 Pri (us)	Pulse 3 Pri (us)	Start Loc (us)	Start Burst Interval (us)	End Burst Interval (us)
1	294533	1	7	100	1662	0	0	294533	0	923076
2	777353	1	11	70	1505	0	0	1073548	923077	1846153
3	1318201	1	13	80	1983	0	0	2393254	1846154	2769230
4	889254	1	12	95	1794	0	0	3284491	2769231	3692307
5	672187	1	15	75	1829	0	0	3958472	3692308	4615384
6	1505827	3	10	90	1470	1554	1265	5466128	4615385	5538461
7	409246	2	9	90	1390	1333	0	5879663	5538462	6461538
8	1197966	1	6	75	1222	0	0	7080352	6461539	7384615
9	1161240	1	17	80	1980	0	0	8242814	7384616	8307692
10	424485	1	5	75	1268	0	0	8669279	8307693	9230769
11	1110888	1	6	70	1632	0	0	9781435	9230770	10153846
12	650995	1	6	90	1362	0	0	10434062	10153847	11076923
13	902010	2	7	90	1898	1556	0	11337434	11076924	12000000

Total number of pulses in waveform = 17



Type 5 Radar Waveform_17

Waveform Num = 17
Num of Bursts = 10
Burst Interval (us)= 1200000

Burst #	Off Time (us)	# Pulses	Chirp (MHz)	PW (us)	Pulse 1 Pri(us)	Pulse 2 Pri(us)	Pulse 3 Pri(us)	Start Loc (us)	Start Burst Interval(us)	End Burst Interval(us)
1	606315	2	17	100	1165	1710	0	606315	0	1199999
2	1510201	3	8	85	1674	1410	1101	2119391	1200000	2399999
3	1310434	1	11	75	1979	0	0	3434010	2400000	3599999
4	1347269	3	15	60	1454	1775	1642	4783258	3600000	4799999
5	701381	3	17	85	1694	1495	1474	5489510	4800000	5999999
6	881724	2	9	50	1682	1467	0	6375897	6000000	7199999
7	1863259	1	19	70	1034	0	0	8242305	7200000	8399999
8	821414	1	15	50	1873	0	0	9064753	8400000	9599999
9	1491437	1	7	80	1904	0	0	10558063	9600000	10799999
10	1102569	1	5	55	1383	0	0	11662536	10800000	11999999

Total number of pulses in waveform = 18

Type 5 Radar Waveform_18

Waveform Num = 18
Num of Bursts = 8
Burst Interval (us)= 1500000

Burst #	Off Time (us)	# Pulses	Chirp (MHz)	PW (us)	Pulse 1 Pri(us)	Pulse 2 Pri(us)	Pulse 3 Pri(us)	Start Loc (us)	Start Burst Interval(us)	End Burst Interval(us)
1	74699	2	10	80	1766	1562	0	74699	0	1499999
2	2593753	2	15	80	1481	1180	0	2671780	1500000	2999999
3	659105	1	11	75	1856	0	0	3333546	3000000	4499999
4	1441689	1	13	50	1386	0	0	4777091	4500000	5999999
5	2389581	2	17	90	1903	1547	0	7168058	6000000	7499999
6	502813	3	7	75	1645	1888	1942	7674321	7500000	8999999
7	2100561	2	16	70	1291	1665	0	9780357	9000000	10499999
8	731585	2	18	50	1456	1566	0	10514898	10500000	11999999

Total number of pulses in waveform = 15

Type 5 Radar Waveform_19

Waveform Num = 19
Num of Bursts = 12
Burst Interval (us)= 1000000

Burst #	Off Time (us)	# Pulses	Chirp (MHz)	PW (us)	Pulse 1 Pri(us)	Pulse 2 Pri(us)	Pulse 3 Pri(us)	Start Loc (us)	Start Burst Interval(us)	End Burst Interval(us)
1	507899	1	16	95	1941	0	0	507899	0	999999
2	1176322	3	15	95	1073	1373	1357	1686162	1000000	1999999
3	947297	1	11	85	1692	0	0	2637262	2000000	2999999
4	891794	1	20	100	1695	0	0	3530748	3000000	3999999
5	773062	2	17	70	1267	1247	0	4305505	4000000	4999999
6	1626679	1	7	90	1416	0	0	5934698	5000000	5999999
7	769787	3	6	95	1999	1477	1156	6705901	6000000	6999999
8	780678	2	10	95	1871	1581	0	7491211	7000000	7999999
9	629430	1	6	55	1205	0	0	8124093	8000000	8999999
10	1741995	1	8	65	1360	0	0	9867293	9000000	9999999
11	381485	3	15	55	1418	1708	1815	10250138	10000000	10999999
12	1030913	2	17	55	1207	1287	0	11285992	11000000	11999999

Total number of pulses in waveform = 21



Type 5 Radar Waveform_20

Waveform Num = 20
 Num of Bursts = 20
 Burst Interval (us)= 600000

Burst #	Off Time (us)	# Pulses	Chirp (MHz)	PW (us)	Pulse 1 Pri (us)	Pulse 2 Pri (us)	Pulse 3 Pri (us)	Start Loc (us)	Start Burst Interval (us)	End Burst Interval (us)
1	492463	2	6	95	1704	1399	0	492463	0	599999
2	156419	2	7	65	1300	1881	0	651925	600000	1199999
3	779710	1	5	90	1058	0	0	1434816	1200000	1799999
4	630915	1	8	85	1311	0	0	2066789	1800000	2399999
5	482876	3	10	55	1281	1657	1599	2550976	2400000	2999999
6	784600	3	19	100	1501	1693	1460	3340113	3000000	3599999
7	811222	3	19	90	1268	1277	1366	4156989	3600000	4199999
8	153320	1	10	60	1689	0	0	4313220	4200000	4799999
9	937037	3	8	95	1461	1468	1235	5251946	4800000	5399999
10	408426	1	17	70	1165	0	0	5664536	5400000	5999999
11	359587	2	6	60	1821	1086	0	6025288	6000000	6599999
12	643497	1	14	95	1725	0	0	6671692	6600000	7199999
13	833020	2	20	75	1061	1281	0	7506437	7200000	7799999
14	860949	1	17	50	1163	0	0	8372728	7800000	8399999
15	237942	3	11	70	1907	1214	1370	8611833	8400000	8999999
16	485804	3	14	95	1620	1580	1822	9102128	9000000	9599999
17	831446	2	19	70	1752	1810	0	9938596	9600000	10199999
18	735005	3	14	90	1454	1924	1441	10677163	10200000	10799999
19	466747	3	7	50	1266	1126	1977	11138729	10800000	11399999
20	417917	1	16	70	1661	0	0	11561015	11400000	11999999

Total number of pulses in waveform = 41

Type 5 Radar Waveform_21

Waveform Num = 21
 Num of Bursts = 8
 Burst Interval (us)= 1500000

Burst #	Off Time (us)	# Pulses	Chirp (MHz)	PW (us)	Pulse 1 Pri (us)	Pulse 2 Pri (us)	Pulse 3 Pri (us)	Start Loc (us)	Start Burst Interval (us)	End Burst Interval (us)
1	829073	2	9	55	1585	1416	0	829073	0	1499999
2	1175345	3	10	85	1497	1232	1324	2007419	1500000	2999999
3	1483545	3	9	100	1158	1245	1859	3495017	3000000	4499999
4	1778758	1	10	70	1326	0	0	5278037	4500000	5999999
5	1590703	2	13	75	1589	1437	0	6870066	6000000	7499999
6	1315074	1	9	60	1839	0	0	8188166	7500000	8999999
7	2067811	2	16	75	1558	1451	0	10257816	9000000	10499999
8	1237938	1	15	95	1521	0	0	11498763	10500000	11999999

Total number of pulses in waveform = 15

Type 5 Radar Waveform_22

Waveform Num = 22
 Num of Bursts = 12
 Burst Interval (us)= 1000000

Burst #	Off Time (us)	# Pulses	Chirp (MHz)	PW (us)	Pulse 1 Pri (us)	Pulse 2 Pri (us)	Pulse 3 Pri (us)	Start Loc (us)	Start Burst Interval (us)	End Burst Interval (us)
1	81551	2	8	60	1625	1268	0	81551	0	999999
2	1623961	1	14	75	1790	0	0	1708405	1000000	1999999
3	1268374	3	5	60	1782	1351	1487	2978569	2000000	2999999
4	879337	2	5	75	1201	1544	0	3862526	3000000	3999999
5	1069203	1	12	95	1632	0	0	4934474	4000000	4999999
6	422363	2	5	90	1828	1992	0	5358469	5000000	5999999
7	1588856	2	20	50	1185	1584	0	6951145	6000000	6999999
8	1027920	2	7	50	1873	1278	0	7981834	7000000	7999999
9	545176	1	14	65	1493	0	0	8530161	8000000	8999999
10	801534	1	20	85	1750	0	0	9333188	9000000	9999999
11	1338351	3	10	95	1468	1630	1517	10673289	10000000	10999999
12	334128	3	12	90	1194	1126	1810	11012032	11000000	11999999

Total number of pulses in waveform = 23



Type 5 Radar Waveform_23

Waveform Num = 23
Num of Bursts = 17
Burst Interval (us) = 705882

Burst #	Off Time (us)	# Pulses	Chirp (MHz)	PW (us)	Pulse 1 Pri (us)	Pulse 2 Pri (us)	Pulse 3 Pri (us)	Start Loc (us)	Start Burst Interval (us)	End Burst Interval (us)
1	976729	1	11	60	1328	0	0	258609	0	705881
2	239609	2	8	55	1755	1201	0	1236666	705882	1411763
3	474547	2	20	60	1745	1499	0	1714169	1411764	2117645
4	437563	2	11	60	1301	1123	0	2154976	2117646	2823527
5	1030433	1	6	80	1867	0	0	3187833	2823528	3529409
6	588183	3	18	65	1778	1907	1123	3777883	3529410	4235291
7	1085055	3	12	75	1467	1200	1228	4867746	4235292	4941173
8	85642	1	17	75	1476	0	0	4957283	4941174	5647055
9	1016207	2	17	50	1755	1353	0	5974966	5647056	6352937
10	774341	3	9	65	1454	1626	1916	6752415	6352938	7058819
11	634668	1	18	95	1945	0	0	7392079	7058820	7764701
12	709489	1	14	70	1236	0	0	8103513	7764702	8470583
13	733814	2	7	60	1355	1829	0	8838563	8470584	9176465
14	671259	1	19	50	1526	0	0	9513006	9176466	9882347
15	996242	3	7	75	1908	1981	1453	10510774	9882348	10588229
16	715176	1	20	70	1559	0	0	11231292	10588230	11294111
17	93774	3	20	100	1656	1740	1915	11326625	11294112	11999993

Total number of pulses in waveform = 32

Type 5 Radar Waveform_24

Waveform Num = 24
Num of Bursts = 9
Burst Interval (us) = 1333333

Burst #	Off Time (us)	# Pulses	Chirp (MHz)	PW (us)	Pulse 1 Pri (us)	Pulse 2 Pri (us)	Pulse 3 Pri (us)	Start Loc (us)	Start Burst Interval (us)	End Burst Interval (us)
1	1192830	2	8	65	1481	1255	0	1192830	0	1333332
2	574008	1	16	95	1280	0	0	1769574	1333333	2666665
3	986675	2	17	90	1423	1825	0	2757529	2666666	3999998
4	1671938	3	17	100	1532	1106	1266	4432715	3999999	5333331
5	1120053	3	9	85	1824	1668	1836	5556672	5333332	6666664
6	1192936	3	7	90	1362	1746	1329	6754936	6666665	7999997
7	1299669	1	9	75	1243	0	0	8059042	7999998	9333330
8	2270850	3	6	75	1024	1363	1414	10331135	9333331	10666663
9	482666	1	14	75	1139	0	0	10817602	10666664	11999996

Total number of pulses in waveform = 19

Type 5 Radar Waveform_25

Waveform Num = 25
Num of Bursts = 13
Burst Interval (us) = 923077

Burst #	Off Time (us)	# Pulses	Chirp (MHz)	PW (us)	Pulse 1 Pri (us)	Pulse 2 Pri (us)	Pulse 3 Pri (us)	Start Loc (us)	Start Burst Interval (us)	End Burst Interval (us)
1	183330	1	8	80	1540	0	0	183330	0	923076
2	1259487	1	8	65	1025	0	0	1444357	923077	1846153
3	1023584	3	15	100	1553	1065	1508	2468966	1846154	2769230
4	1188479	2	15	95	1261	1646	0	3661571	2769231	3692307
5	872227	3	14	60	1912	1383	1564	4536705	3692308	4615384
6	273861	1	5	65	1018	0	0	4815425	4615385	5538461
7	1630113	2	15	75	1691	1101	0	6446556	5538462	6461538
8	930402	3	13	65	1242	1489	1580	7379750	6461539	7384615
9	540532	1	11	85	1429	0	0	7924593	7384616	8307692
10	495946	3	15	75	1771	1279	1832	8421968	8307693	9230769
11	1600448	3	15	70	1695	1312	1878	10027298	9230770	10153846
12	465267	1	14	70	1424	0	0	10497450	10153847	11076923
13	1308701	3	14	55	1776	1472	1942	11807575	11076924	12000000

Total number of pulses in waveform = 27



Type 5 Radar Waveform_26

Waveform Num = 26
 Num of Bursts = 19
 Burst Interval (us)= 631579

Burst #	Off Time (us)	# Pulses	Chirp (MHz)	PW (us)	Pulse 1 Pri (us)	Pulse 2 Pri (us)	Pulse 3 Pri (us)	Start Loc (us)	Start Burst Interval (us)	End Burst Interval (us)
1	825770	2	15	65	1013	1420	0	383330	0	631578
2	655920	3	10	95	1256	1475	1478	1211533	631579	1263157
3	76463	3	20	55	1287	1406	1918	1871662	1263158	1894736
4	1112583	2	14	45	1926	1847	0	1952736	1894737	2526315
5	325725	1	8	75	1079	0	0	3069092	2526316	3157894
6	842357	1	13	85	1949	0	0	3395896	3157895	3789473
7	742641	3	9	80	1246	1149	1397	4240202	3789474	4421052
8	407421	3	6	70	1412	1836	1597	4986635	4421053	5052631
9	580862	1	6	90	1151	0	0	5398901	5052632	5684210
10	459396	3	13	85	1176	1097	1901	5980914	5684211	6315789
11	777079	3	6	95	1770	1514	1123	6444483	6315790	6947368
12	383769	3	18	100	1114	1863	1237	7225969	6947369	7578947
13	956757	1	7	65	1608	0	0	7613952	7578948	8210526
14	423765	1	8	95	1134	0	0	8572317	8210527	8842105
15	985049	2	20	55	1875	1752	0	8997216	8842106	9473684
16	152188	3	14	85	1337	1100	1370	9985892	9473685	10105263
17	712464	3	17	70	1883	1770	1253	10141887	10105264	10736842
18	1011903	3	8	70	1130	1856	1570	10859257	10736843	11368421
19		3	20	50	1674	1786	1417	11875716	11368422	12000000

Total number of pulses in waveform = 44

Type 5 Radar Waveform_27

Waveform Num = 27
 Num of Bursts = 17
 Burst Interval (us)= 705882

Burst #	Off Time (us)	# Pulses	Chirp (MHz)	PW (us)	Pulse 1 Pri (us)	Pulse 2 Pri (us)	Pulse 3 Pri (us)	Start Loc (us)	Start Burst Interval (us)	End Burst Interval (us)
1	143980	1	9	70	1585	0	0	143980	0	705881
2	1115517	1	18	75	1414	0	0	1261082	705882	1411763
3	244264	3	11	90	1170	1754	1765	1506760	1411764	2117645
4	726856	3	19	95	1441	1372	1678	2745703	2117646	2823527
5	304875	2	16	50	1618	1785	0	3477050	2823528	3529409
6	866385	3	5	90	1533	1157	1329	3785328	3529410	4235291
7	325275	2	10	70	1585	1878	0	4655732	4235292	4941173
8	1099374	1	11	100	1642	0	0	4984470	4941174	5647055
9	300114	2	17	95	1893	1339	0	6085486	5647056	6352937
10	1192933	1	8	50	1999	0	0	6388832	6352938	7058819
11	867935	1	7	95	1856	0	0	7583764	7058820	7764701
12	701811	1	17	50	1672	0	0	8453555	7764702	8470583
13	130008	3	11	90	1479	1049	1525	9157038	8470584	9176465
14	1232463	2	11	50	1125	1525	0	9291099	9176466	9882347
15	451209	3	5	55	1406	1144	1798	10526212	9882348	10588229
16	930920	1	10	60	1998	0	0	10981769	10588230	11294111
17		1	13	100	1793	0	0	11914687	11294112	11999993

Total number of pulses in waveform = 31

Type 5 Radar Waveform_28

Waveform Num = 28
 Num of Bursts = 10
 Burst Interval (us)= 1200000

Burst #	Off Time (us)	# Pulses	Chirp (MHz)	PW (us)	Pulse 1 Pri (us)	Pulse 2 Pri (us)	Pulse 3 Pri (us)	Start Loc (us)	Start Burst Interval (us)	End Burst Interval (us)
1	1032762	1	18	75	1643	0	0	1032762	0	1199999
2	523283	3	12	50	1186	1953	1992	1557688	1200000	2399999
3	1311554	3	5	70	1551	1071	1307	2874373	2400000	3599999
4	1266535	1	11	50	1232	0	0	4144837	3600000	4799999
5	1163232	2	12	75	1304	1046	0	5309301	4800000	5999999
6	1787831	2	9	50	1644	1434	0	7099482	6000000	7199999
7	1268644	2	7	90	1097	1389	0	8371204	7200000	8399999
8	1057928	1	20	85	1785	0	0	9431618	8400000	9599999
9	777361	3	20	65	1360	1562	1396	10210764	9600000	10799999
10	1274630	2	20	50	1447	1370	0	11489712	10800000	11999999

Total number of pulses in waveform = 20



Type 5 Radar Waveform_29

```

Waveform Num = 29
Num of Bursts = 30
Burst Interval (us)= 600000

```

Burst #	Off Time (us)	# Pulses	Chirp (MHz)	PW (us)	Pulse 1 Pri (us)	Pulse 2 Pri (us)	Pulse 3 Pri (us)	Start Loc (us)	Start Burst Interval (us)	End Burst Interval (us)
1	844778	1	5	65	1714	0	0	544778	0	599999
2	182628	3	7	55	1787	1254	1968	729120	600000	1199999
3	851220	1	17	75	1990	0	0	1585339	1200000	1799999
4	636769	3	6	70	1263	1422	1416	2223088	1800000	2399999
5	731380	3	6	70	1627	1675	1284	2958569	2400000	2999999
6	167808	1	6	65	1657	0	0	3130863	3000000	3599999
7	561884	2	6	75	1242	1299	0	3694404	3600000	4199999
8	606577	3	9	65	1372	1062	1785	4303522	4200000	4799999
9	1084962	2	10	100	1933	1821	0	5392703	4800000	5399999
10	256235	2	6	85	1464	1098	0	5651692	5400000	5999999
11	767576	3	8	70	1787	1033	1792	6421830	6000000	6599999
12	651755	1	14	100	1110	0	0	7078197	6600000	7199999
13	125104	2	9	70	1282	1211	0	7204411	7200000	7799999
14	914700	2	5	75	1870	1887	0	8121604	7800000	8399999
15	814495	2	13	50	1131	1914	0	8939856	8400000	8999999
16	173810	2	11	75	1211	1725	0	9116711	9000000	9599999
17	562795	3	16	50	1751	1574	1116	9682442	9600000	10199999
18	846763	1	12	50	1506	0	0	10536636	10200000	10799999
19	679848	2	19	85	1938	1489	0	11214990	10800000	11399999
20	366214	1	10	55	1474	0	0	11584631	11400000	11999999

Total number of pulses in waveform = 40

Type 5 Radar Waveform_30

```

Waveform Num = 30
Num of Bursts = 9
Burst Interval (us)= 1333333

```

Burst #	Off Time (us)	# Pulses	Chirp (MHz)	PW (us)	Pulse 1 Pri (us)	Pulse 2 Pri (us)	Pulse 3 Pri (us)	Start Loc (us)	Start Burst Interval (us)	End Burst Interval (us)
1	607724	3	11	85	1750	1829	1097	607724	0	1333332
2	1044190	3	14	55	1614	1780	1676	1656590	1333333	2666665
3	1424421	2	20	50	1225	1142	0	3086081	2666666	3999998
4	1135957	1	16	65	1097	0	0	4224405	3999999	5333331
5	1391554	1	7	60	1367	0	0	5617056	5333332	6666664
6	1583515	2	12	65	1004	1125	0	7201938	6666665	7999997
7	1811808	3	7	50	1849	1132	1634	9015875	7999998	9333330
8	1062088	2	14	55	1862	1635	0	10082578	9333331	10666663
9	1156491	2	10	90	1366	1463	0	11242566	10666664	11999996

Total number of pulses in waveform = 19

Radar Type 6 - Radar Statistical Performance

Trail #	Test Freq. (MHz)	1=Detection 0=No Detection	Trail #	Test Freq. (MHz)	1=Detection 0=No Detection
1	5669	1	16	5669	1
2	5669	1	17	5669	1
3	5669	1	18	5669	1
4	5669	1	19	5669	1
5	5669	1	20	5669	1
6	5669	1	21	5669	1
7	5669	1	22	5669	1
8	5669	1	23	5669	1
9	5669	1	24	5669	1
10	5669	1	25	5669	1
11	5669	1	26	5669	1
12	5669	1	27	5669	1
13	5669	1	28	5669	1
14	5669	1	29	5669	1
15	5669	1	30	5669	1
Detection Percentage (%)					100%

Radar waveform #1			Radar waveform #2		
Hopping Number	Frequency (MHz)	Pulse Start (ms)	Hopping Number	Frequency (MHz)	Pulse Start (ms)
9	5552	27	1	5571	3
12	5565	36	17	5550	51
18	5582	54	25	5583	75
27	5545	81	26	5541	78
29	5580	87	28	5547	84
41	5588	123	32	5569	96
43	5596	129	35	5589	105
65	5598	195	40	5588	120
67	5555	201	42	5543	126
75	5590	225	44	5590	132
81	5553	243	45	5549	135
83	5546	249	46	5598	138
90	5564	270	52	5546	156
--	--	--	61	5545	183
--	--	--	70	5576	210
--	--	--	84	5542	252

Radar waveform #3			Radar waveform #4		
Hopping Number	Frequency (MHz)	Pulse Start (ms)	Hopping Number	Frequency (MHz)	Pulse Start (ms)
4	5543	12	0	5575	0
7	5573	21	18	5592	54
41	5598	123	31	5568	93
59	5574	177	39	5576	117
80	5595	240	44	5540	132
81	5548	243	54	5565	162
91	5562	273	60	5573	180
97	5591	291	68	5550	204
--	--	--	77	5581	231

Radar waveform #5			Radar waveform #6		
Hopping Number	Frequency (MHz)	Pulse Start (ms)	Hopping Number	Frequency (MHz)	Pulse Start (ms)
5	5562	15	0	5559	0
13	5569	39	8	5573	24
19	5547	57	17	5562	51
37	5571	111	28	5580	84
40	5540	120	30	5582	90
52	5570	156	43	5550	129
61	5554	183	49	5543	147
68	5568	204	51	5593	153
71	5541	213	56	5546	168
73	5584	219	66	5570	198
80	5577	240	67	5555	201
89	5552	267	77	5569	231
97	5546	291	95	5547	285
--	--	--	96	5583	288

Radar waveform #7			Radar waveform #8		
Hopping Number	Frequency (MHz)	Pulse Start (ms)	Hopping Number	Frequency (MHz)	Pulse Start (ms)
4	5568	12	6	5594	18
8	5573	24	8	5574	24
10	5570	30	15	5565	45
15	5595	45	24	5549	72
26	5567	78	29	5561	87
28	5546	84	42	5557	126
38	5562	114	57	5579	171
42	5590	126	61	5560	183
46	5554	138	66	5543	198
48	5544	144	86	5598	258
51	5584	153	91	5572	273
55	5543	165	94	5576	282
61	5582	183	--	--	--
63	5561	189	--	--	--
70	5578	210	--	--	--
75	5598	225	--	--	--
84	5555	252	--	--	--
91	5585	273	--	--	--

Radar waveform #9			Radar waveform #10		
Hopping Number	Frequency (MHz)	Pulse Start (ms)	Hopping Number	Frequency (MHz)	Pulse Start (ms)
3	5570	9	0	5555	0
4	5586	12	3	5580	9
13	5573	39	9	5543	27
16	5567	48	17	5572	51
18	5585	54	18	5564	54
27	5557	81	48	5578	144
53	5589	159	51	5574	153
64	5575	192	52	5539	156
91	5580	273	54	5593	162
94	5548	282	57	5573	171
95	5572	285	60	5576	180
--	--	--	70	5594	210
--	--	--	72	5589	216
--	--	--	75	5563	225
--	--	--	92	5590	276

Radar waveform #11			Radar waveform #12		
Hopping Number	Frequency (MHz)	Pulse Start (ms)	Hopping Number	Frequency (MHz)	Pulse Start (ms)
5	5582	15	6	5561	18
11	5589	33	7	5582	21
24	5581	72	29	5551	87
29	5586	87	41	5589	123
42	5546	126	50	5572	150
53	5585	159	56	5542	168
57	5559	171	85	5571	255
65	5554	195	90	5576	270
68	5597	204	--	--	--
69	5593	207	--	--	--
79	5563	237	--	--	--
80	5544	240	--	--	--
81	5543	243	--	--	--
99	5568	297	--	--	--

Radar waveform #13			Radar waveform #14		
Hopping Number	Frequency (MHz)	Pulse Start (ms)	Hopping Number	Frequency (MHz)	Pulse Start (ms)
5	5595	15	1	5588	3
9	5546	27	5	5546	15
16	5572	48	16	5550	48
25	5589	75	25	5567	75
27	5575	81	26	5591	78
38	5550	114	54	5594	162
44	5559	132	60	5551	180
49	5588	147	64	5560	192
51	5567	153	73	5566	219
63	5592	189	76	5579	228
93	5586	279	77	5574	231
--	--	--	80	5592	240

Radar waveform #15			Radar waveform #16		
Hopping Number	Frequency (MHz)	Pulse Start (ms)	Hopping Number	Frequency (MHz)	Pulse Start (ms)
5	5591	15	28	5549	84
6	5563	18	30	5546	90
12	5579	36	31	5542	93
17	5555	51	35	5598	105
26	5541	78	40	5539	120
32	5568	96	57	5561	171
33	5566	99	71	5589	213
34	5571	102	79	5594	237
51	5546	153	84	5587	252
53	5584	159	94	5566	282
54	5539	162	--	--	--
63	5573	189	--	--	--
67	5575	201	--	--	--
77	5680	231	--	--	--
78	5544	234	--	--	--
82	5548	246	--	--	--
91	5581	273	--	--	--

Radar waveform #17			Radar waveform #18		
Hopping Number	Frequency (MHz)	Pulse Start (ms)	Hopping Number	Frequency (MHz)	Pulse Start (ms)
5	5560	15	8	5557	24
14	5561	42	9	5548	27
21	5568	63	12	5585	36
22	5546	66	18	5562	54
25	5542	75	23	5571	69
27	5540	81	24	5541	72
31	5578	93	25	5599	75
36	5570	108	53	5597	159
74	5555	222	58	5559	174
75	5556	225	80	5572	240
84	5596	252	91	5574	273
92	5563	276	94	5550	282

Radar waveform #19			Radar waveform #20		
Hopping Number	Frequency (MHz)	Pulse Start (ms)	Hopping Number	Frequency (MHz)	Pulse Start (ms)
0	5581	0	0	5583	0
7	5549	21	31	5594	93
22	5575	66	51	5571	153
30	5591	90	52	5564	156
32	5580	96	57	5561	171
33	5558	99	60	5542	180
37	5576	111	72	5584	216
46	5572	138	87	5543	261
48	5570	144	88	5592	264
51	5592	153	89	5574	267
58	5577	174	90	5563	270
60	5598	180	98	5570	294
61	5552	183	--	--	--
69	5545	207	--	--	--
82	5587	246	--	--	--
84	5593	252	--	--	--
Radar waveform #21			Radar waveform #22		

Hopping Number	Frequency (MHz)	Pulse Start (ms)	Hopping Number	Frequency (MHz)	Pulse Start (ms)
3	5580	9	9	5554	27
4	5550	12	10	5565	30
9	5594	27	22	5570	66
1	5539	3	46	5599	138
13	5589	39	54	5555	162
22	5586	66	56	5540	168
23	5557	69	57	5572	171
34	5565	102	70	5551	210
43	5559	129	72	5595	216
50	5593	150	76	5592	228
52	5545	156	84	5563	252
55	5596	165	97	5566	291
68	5599	204	98	5573	294
73	5558	219	--	--	--
83	5575	249	--	--	--
87	5552	261	--	--	--
90	5572	270	--	--	--

Radar waveform #23			Radar waveform #24		
Hopping Number	Frequency (MHz)	Pulse Start (ms)	Hopping Number	Frequency (MHz)	Pulse Start (ms)
15	5599	45	4	5539	12
34	5563	102	8	5580	24
37	5560	111	15	5574	45
40	5576	120	16	5556	48
41	5559	123	18	5577	54
52	5568	156	31	5583	93
63	5594	189	40	5567	120
68	5583	204	42	5560	126
71	5541	213	54	5552	162
79	5592	237	75	5578	225
86	5579	258	79	5553	237
89	5572	267	74	5558	222
--	--	--	90	5584	270

Radar waveform #25			Radar waveform #26		
Hopping Number	Frequency (MHz)	Pulse Start (ms)	Hopping Number	Frequency (MHz)	Pulse Start (ms)
2	5563	6	4	5553	12
13	5544	39	12	5560	36
17	5576	51	13	5572	39
25	5559	75	23	5580	69
57	5552	171	25	5587	75
55	5554	165	28	5584	84
75	5545	225	32	5592	96
79	5598	237	36	5582	108
82	5543	246	45	5542	135
87	5567	261	48	5586	144
99	5597	297	51	5565	153
--	--	--	52	5571	156
--	--	--	64	5554	192
--	--	--	72	5564	216
--	--	--	81	5585	243
--	--	--	94	5547	282

Radar waveform #27			Radar waveform #28		
Hopping Number	Frequency (MHz)	Pulse Start (ms)	Hopping Number	Frequency (MHz)	Pulse Start (ms)
14	5566	42	5	5546	15
25	5599	75	18	5573	54
31	5578	93	21	5550	63
49	5563	147	26	5553	78
62	5564	186	27	5596	81
63	5594	189	35	5591	105
75	5574	225	39	5577	117
95	5545	285	42	5578	126
--	--	--	47	5572	141
--	--	--	53	5549	159
--	--	--	56	5529	168
--	--	--	60	5582	180
--	--	--	76	5584	228
--	--	--	79	5583	237
--	--	--	89	5580	267

Radar waveform #29			Radar waveform #30		
Hopping Number	Frequency (MHz)	Pulse Start (ms)	Hopping Number	Frequency (MHz)	Pulse Start (ms)
6	5586	18	3	5582	9
24	5594	72	9	5584	27
28	5580	84	48	5596	144
30	5568	90	56	5579	168
40	5576	120	64	5576	192
44	5584	132	80	5568	240
47	5558	141	99	5572	297
54	5578	162	--	--	--
61	5596	183	--	--	--
64	5589	192	--	--	--
71	5549	213	--	--	--
75	5556	225	--	--	--
76	5543	228	--	--	--
83	5562	249	--	--	--
84	5561	252	--	--	--

6. CONCLUSION

The data collected relate only the item(s) tested and show that the **WiFi Concurrent 4 Port GE LAN VoIP Ethernet Gateway with USB FCC ID: 2ABLK-844E-1** is in compliance with Part 15E of the FCC Rules.

The End