



RADIO TEST REPORT

Test Report No.: 10126812S

Applicant : YAMAHA MOTOR ELECTRONICS CO., LTD.
Type of Equipment : IMMOBILIZER
Model No. : 5SL-00
Test regulation : FCC Part15 Subpart C: 2013
FCC ID : 2ABKW5SL-00
Test result : Complied

1. This test report shall not be reproduced in full or partial, without the written approval of UL Japan, Inc.
2. The results in this report apply only to the sample tested.
3. This sample tested is in compliance with the limits of the above regulation.
4. The test results in this test report are traceable to the national or international standards.
5. This test report must not be used by the customer to claim product certification, approval, or endorsement by any agency of the Federal Government.
6. The opinions and the interpretations to the result of the description in this report are outside scopes where UL Japan has been accredited.

Date of test: November 26 to December 4, 2013

Representative test engineer:

Akira Sato
Engineer of WiSE Japan,
UL Verification Service

Approved by :

Ichiro Isozaki
Leader of WiSE Japan,
UL Verification Service



- The testing in which "Non-accreditation" is displayed is outside the accreditation scopes in UL Japan.
 There is no testing item of "Non-accreditation".

UL Japan, Inc.

Shonan EMC Lab.

1-22-3 Megumigaoka, Hiratsuka-shi, Kanagawa-ken, 259-1220 JAPAN

Telephone : +81 463 50 6400

Facsimile : +81 463 50 6401

13-EM-F0429

REVISION HISTORY

Original Test Report No.: 10126812S

Revision	Test report No.	Date	Page revised	Contents
- (Original)	10126812S	December 26, 2013	-	-
1	10126812S	January 10, 2014	8, 12-13	Correction of calculation formula
2	10126812S	January 10, 2014	12-13	Correction of data sheet

Contents

	<u>Page</u>
SECTION 1: Customer information	4
SECTION 2: Equipment under test (E.U.T.)	4
SECTION 3: Test specification, procedures & results	5
SECTION 4: Operation of E.U.T. during testing.....	7
SECTION 5: Radiated emission (Fundamental and Spurious emission)	8
SECTION 6: 26dB bandwidth & Occupied bandwidth (99%)	10
Contents of APPENDIXES.....	11
APPENDIX 1: Data of radio tests	12
APPENDIX 2: Test instruments	16
APPENDIX 3: Photographs of test setup	17

UL Japan, Inc.

Shonan EMC Lab.

1-22-3 Megumigaoka, Hiratsuka-shi, Kanagawa-ken, 259-1220 JAPAN

Telephone : +81 463 50 6400

Facsimile : +81 463 50 6401

SECTION 1: Customer information

Company Name : YAMAHA MOTOR ELECTRONICS CO., LTD.
Address : 1450-6 Mori, Mori-machi, Shuchi-gun, Shizuoka 437-0292 JAPAN
Telephone Number : +81 538 85 0213
Facsimile Number : +81 538 85 0456
Contact Person : Ami Yasui

SECTION 2: Equipment under test (E.U.T.)

2.1 Identification of E.U.T.

Type of Equipment : IMMOBILIZER
Model Number : 5SL-00
Serial Number : 3Y0001B
Rating : DC 12V
Country of Mass-production : Japan
Condition of EUT : Engineering prototype
(Not for Sale: This sample is equivalent to mass-produced items.)
Receipt Date of Sample : September 24, 2013
Modification of EUT : No modification by the test lab.

2.2 Product description

Model: 5SL-00 (referred to as the EUT in this report) is an IMMOBILIZER.

The clock frequency used in EUT: CPU (4MHz), BASE STATION IC (2MHz)

- When the key that has registered in this system turns on the main switch, ECU puts engine into operation.
- When the key that not be registered in this system turns on the main switch, ECU does not put engine into operation.
- LED is flashing after turning off the main switch, and tells that The Immobilizer Unit is operating. And a theft act is deterred.

Equipment type : Transceiver
Frequency of operation : 134.2kHz
Type of modulation : Pulse Width Modulation
Antenna type : Loop
Antenna gain with cable loss : -
Antenna connector type : -
ITU code : LOD
Power source : Vehicle-regulated
Operation temperature range : -10 to +60 deg.C.

FCC 15.31 (e)

The EUT provides stable voltage (DC5V) constantly to the wireless transmitter regardless of input voltage. Therefore, this EUT complies with the requirement.

FCC 15.203

The equipment and its antenna comply with this requirement since the antenna is mounted inside of the EUT.

UL Japan, Inc.

Shonan EMC Lab.

1-22-3 Megumigaoka, Hiratsuka-shi, Kanagawa-ken, 259-1220 JAPAN

Telephone : +81 463 50 6400
Facsimile : +81 463 50 6401

SECTION 3: Test specification, procedures & results

3.1 Test specification

Test specification : FCC Part 15 Subpart C: 2013,
final revised on September 30, 2013 and effective October 30, 2013
Title : FCC 47CFR Part15 Radio Frequency Device Subpart C Intentional Radiators
Section 15.207 Conducted limits
Section 15.209 Radiated emission limits, general requirements

3.2 Procedures & Results

Item	Test Procedure	Specification	Remarks	Deviation	Worst Margin	Results
Conducted emission	ANSI C63.4:2009 7. AC powerline conducted emission measurements	FCC 15.207	-	N/A *1)	N/A	N/A
Electric field strength of Fundamental emission	ANSI C63.4:2009 13. Measurement of intentional radiators	FCC 15.209	Radiated	N/A	31.3dB Freq.: 0.13420MHz Polarization: 0 deg. Detector: Average	Complied
Electric field strength of Spurious emission	ANSI C63.4:2009 13. Measurement of intentional radiators	FCC 15.209	Radiated	N/A	2.1dB Freq.: 30.142MHz Polarization: Vertical Detector: Quasi-Peak	Complied
-26dB bandwidth	ANSI C63.4:2009 13. Measurement of intentional radiators	Reference data	Radiated	N/A	-	-

Note: UL Japan's Work Procedures No. 13-EM-W0420 and 13-EM-W0422

*1) The test is not applicable since the EUT does not have AC Mains.

3.3 Addition to standard

Item	Test Procedure	Specification	Remarks	Worst Margin	Results
Occupied Bandwidth (99%)	ANSI C63.4:2009 13. Measurement of intentional radiators, RSS-Gen 4.6.1	-	Radiated	-	-

Note: UL Japan's Work Procedures No. 13-EM-W0420 and 13-EM-W0422

* Other than above, no addition, exclusion nor deviation has been made from the standard.

UL Japan, Inc.

Shonan EMC Lab.

1-22-3 Megumigaoka, Hiratsuka-shi, Kanagawa-ken, 259-1220 JAPAN

Telephone : +81 463 50 6400

Facsimile : +81 463 50 6401

3.4 Uncertainty

The following uncertainties have been calculated to provide a confidence level of 95% using a coverage factor k=2.

Item	Frequency range	No.1 SAC* ¹ (±)	No.2 SAC (±)	No.3 SAC (±)
Radiated emission (Measurement distance: 3m)	9kHz-30MHz	3.7 dB	3.7 dB	3.6 dB
	30MHz-300MHz	4.8 dB	5.0 dB	4.8 dB
	300MHz-1GHz	5.0 dB	5.0 dB	4.8 dB
	1GHz-18GHz	4.9 dB	4.9 dB	4.9 dB

*1: SAC=Semi-Anechoic Chamber

The data listed in this report meets the limits unless the uncertainty is taken into consideration.

Bandwidth Measurement:

Uncertainty for this test was: (±) 5.4%

3.5 Test location

UL Japan, Inc. Shonan EMC Lab.

1-22-3, Megumigaoka, Hiratsuka-shi, Kanagawa-ken 259-1220 JAPAN

Telephone number : +81 463 50 6400

Facsimile number : +81 463 50 6401

JAB Accreditation No. : RTL02610

	FCC Registration No.	IC Registration No.	Width x Depth x Height (m)	Size of reference ground plane (m) / horizontal conducting plane	Maximum measurement distance
<input type="checkbox"/> No.1 Semi-anechoic chamber	697847	2973D-1	20.6 x 11.3 x 7.65	20.6 x 11.3	10m
<input checked="" type="checkbox"/> No.2 Semi-anechoic chamber	697847	2973D-2	20.6 x 11.3 x 7.65	20.6 x 11.3	10m
<input type="checkbox"/> No.3 Semi-anechoic chamber	697847	2973D-3	12.7 x 7.7 x 5.35	12.7 x 7.7	5m
<input type="checkbox"/> No.4 Semi-anechoic chamber	-	-	8.1 x 5.1 x 3.55	8.1 x 5.1	-
<input type="checkbox"/> No.1 Shielded room	-	-	6.8 x 4.1 x 2.7	6.8 x 4.1	-
<input type="checkbox"/> No.2 Shielded room	-	-	6.8 x 4.1 x 2.7	6.8 x 4.1	-
<input type="checkbox"/> No.3 Shielded room	-	-	6.3 x 4.7 x 2.7	6.3 x 4.7	-
<input type="checkbox"/> No.4 Shielded room	-	-	4.4 x 4.7 x 2.7	4.4 x 4.7	-
<input type="checkbox"/> No.5 Shielded room	-	-	7.8 x 6.4 x 2.7	7.8 x 6.4	-
<input type="checkbox"/> No.6 Shielded room	-	-	7.8 x 6.4 x 2.7	7.8 x 6.4	-

3.6 Test setup, Data of test & Test instruments

Refer to APPENDIX 1 to 3.

UL Japan, Inc.

Shonan EMC Lab.

1-22-3 Megumigaoka, Hiratsuka-shi, Kanagawa-ken, 259-1220 JAPAN

Telephone : +81 463 50 6400

Facsimile : +81 463 50 6401

SECTION 4: Operation of E.U.T. during testing

4.1 Operating mode

The EUT exercise program used during testing was designed to exercise the various system components in a manner similar to typical use.

Operating mode	Detail
Transmitting (134.2kHz)	Continuous transmitting 134.2kHz (modulated)

Power settings : Setting is controlled by the firmware and cannot be changed.
Software : N/A

Justification: The system was configured in typical fashion (as customer would normally use it) for testing.

4.2 Configuration and peripherals

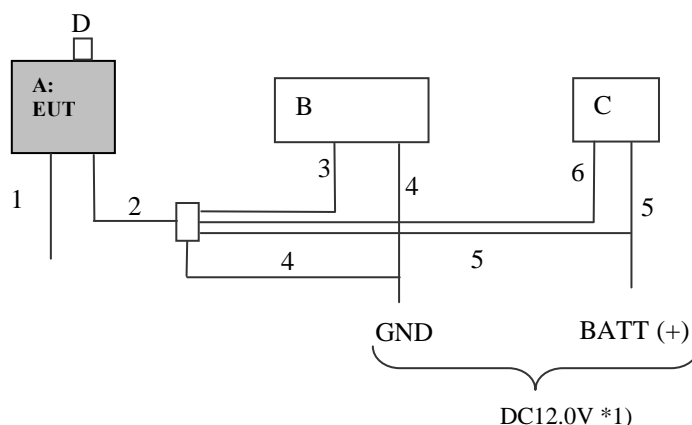

* Test data was taken under worse case conditions.

Description of EUT and support equipment

No.	Item	Model number	Serial number	Manufacturer	Remarks
A	IMMOBILIZER	5SL-00	3Y0001B	YAMAHA MOTOR ELECTRONICS	EUT
B	METER	-	5VK4 3 29R	YAMAHA MOTOR ELECTRONICS	-
C	Dummy Switch	-	-	-	-
D	Key	-	-	YAMAHA MOTOR ELECTRONICS	-

*1) DC power supply (Model No.: PAN35-10A) was used for DC 12.0V input.

List of cables used

No.	Name	Length (m)	Shield (Cable)	Shield (Connector)	Remarks
1	Connection cable to the vehicle *2)	0.4	Unshielded	Unshielded	-
2	Communication 2 cable	0.5	Unshielded	Unshielded	-
3	METER cable	0.5	Unshielded	Unshielded	-
4	GND cable	1.2	Unshielded	Unshielded	-
5	BATT cable	1.2	Unshielded	Unshielded	-
6	Dummy switch cable	2.5	Unshielded	Unshielded	-

*2) Cable No. 1 is not connected electrically to the immobilizer.

UL Japan, Inc.

Shonan EMC Lab.

1-22-3 Megumigaoka, Hiratsuka-shi, Kanagawa-ken, 259-1220 JAPAN

Telephone : +81 463 50 6400

Facsimile : +81 463 50 6401

SECTION 5: Radiated emission (Fundamental and Spurious emission)

5.1 Operating environment

The test was carried out in a semi-anechoic chamber.

Temperature : Refer to APPENDIX 2.
Humidity : Refer to APPENDIX 2.

5.2 Test configuration

EUT was placed on a platform of nominal size, 1.0m by 1.5m, raised 0.8m above the conducting ground plane. The table is made of Styrofoam and covered with polyvinyl chloride. That has very low permittivity. The rear of EUT, including its peripherals was aligned and flushed with rear of tabletop. I/O cables that were connected to the peripherals were bundled in center. They were folded back and for the forming a bundle 30cm to 40cm long and were hanged at a 40cm height to the ground plane. Photographs of the set up are shown in Appendix 1.

5.3 Test conditions

Frequency range : 9kHz - 1GHz
EUT position : Table top

5.4 Test procedure

The Radiated Electric Field Strength intensity has been measured with a ground plane and at a distance of 3m
Frequency: From 9kHz to 30MHz at distance 3m

The EUT was rotated a full revolution in order to obtain the maximum value of the electric field intensity.

The measurements were performed for vertical polarization and horizontal polarization. Drawing of the antenna direction is shown in Figure 1.

Frequency: From 30MHz to 1GHz at distance 3m (Refer to Figure 2).

The measuring antenna height was varied between 1 and 4m and EUT was rotated a full revolution in order to obtain the maximum value of the electric field intensity.

The measurements were performed for both vertical and horizontal antenna polarization.

Measurements were performed with QP, PK, and AV detector.

The radiated emission measurements were made with the following detector function.

<9kHz to 30MHz>

	9kHz to 90kHz & 110kHz to 150kHz	90kHz to 110kHz	150kHz to 490kHz	490kHz to 30MHz
Detector type	PK/AV	QP	PK/AV	QP
IF Bandwidth	200Hz *1)	200Hz *1)	9kHz *1)	9kHz *2)
Measuring antenna	Loop			

* FCC 15 Section 15.31 (f)(2) (9kHz-30MHz)

*1) Distance Factor: $40 \times \log(3\text{m}/300\text{m}) = -80\text{dB}$

*2) Distance Factor: $40 \times \log(3\text{m}/30\text{m}) = -40\text{dB}$

<30MHz to 1GHz>

	30MHz to 1GHz
Detector type	QP
IF Bandwidth	120kHz
Measuring antenna	Biconical (30-299.99MHz) Logperiodic (300MHz-1GHz)

UL Japan, Inc.

Shonan EMC Lab.

1-22-3 Megumigaoka, Hiratsuka-shi, Kanagawa-ken, 259-1220 JAPAN

Telephone : +81 463 50 6400

Facsimile : +81 463 50 6401

The noise levels were measured at each position of all three axes X, Y and Z, and the position that has the maximum noise was determined. With the position, the noise levels of all the frequencies were measured.
Worst case: Below 30MHz: Horizontal: Z-axis, Vertical: Y-axis, Above 30MHz: Horizontal: X-axis, Vertical: Y-axis

5.5 Results

Summary of the test results : Pass

Refer to APPENDIX 2.

Figure 1. Direction of the Loop Antenna

Side View (Vertical)

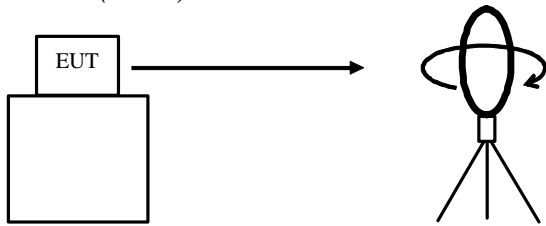

Top View (Horizontal)

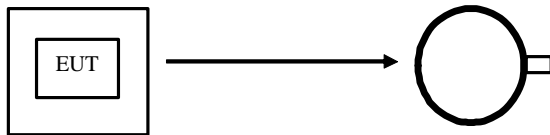

Antenna was not rotated.

Top View (Vertical)

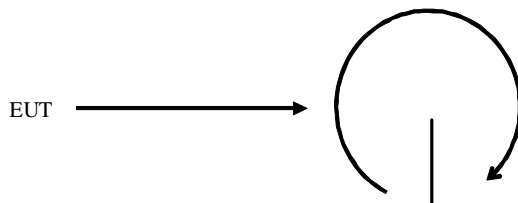

Front side: 0 deg.
Forward direction: clockwise

Figure 2. Antenna angle

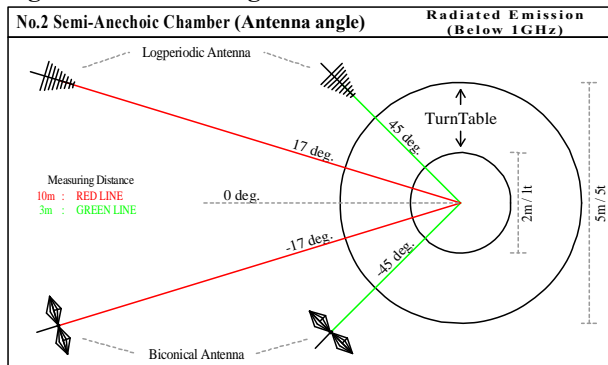

UL Japan, Inc.

Shonan EMC Lab.

1-22-3 Megumigaoka, Hiratsuka-shi, Kanagawa-ken, 259-1220 JAPAN

Telephone : +81 463 50 6400

Facsimile : +81 463 50 6401

SECTION 6: 26dB bandwidth & Occupied bandwidth (99%)

Test procedure

The bandwidth was measured with a spectrum analyzer and a search coil placed by the EUT.

Summary of the test results: Pass
Refer to APPENDIX 2.

UL Japan, Inc.

Shonan EMC Lab.

1-22-3 Megumigaoka, Hiratsuka-shi, Kanagawa-ken, 259-1220 JAPAN

Telephone : +81 463 50 6400

Facsimile : +81 463 50 6401

Contents of APPENDIXES

APPENDIX 1: Data of Radio tests

Radiated emission
Bandwidth

APPENDIX 2: Test instruments

Test instruments

APPENDIX 3: Photographs of test setup

Radiated emission
Pre-check of the worst case

UL Japan, Inc.

Shonan EMC Lab.

1-22-3 Megumigaoka, Hiratsuka-shi, Kanagawa-ken, 259-1220 JAPAN

Telephone : +81 463 50 6400

Facsimile : +81 463 50 6401

DATA OF RADIATED EMISSION (below 30MHz) TEST

UL Japan,Inc. Shonan EMC Lab. No.2 Anechoic Chamber
 Date : 2013/11/26

Company : YAMAHA MOTOR ELECTRONICS CO., LTD Mode : Transmitting (134.2kHz)
 Kind of EUT : IMMOBILIZER Order No. : 10126812S
 Model No. : 5SL-00 Power : DC 12V
 Serial No. : 3Y0001B Temp./Humi. : 24deg.C. / 36%RH
 Remarks : Loop Antenna:Vertical, EUT Axis:Y

Limit1 : FCC15.209 (a) 3m, 9-90kHz:AV, 110-490kHz:AV, other:QP
 Limit2 : FCC15.209 (a) 3m, 9-90kHz:PK, 110-490kHz:PK, Engineer : Akira Sato

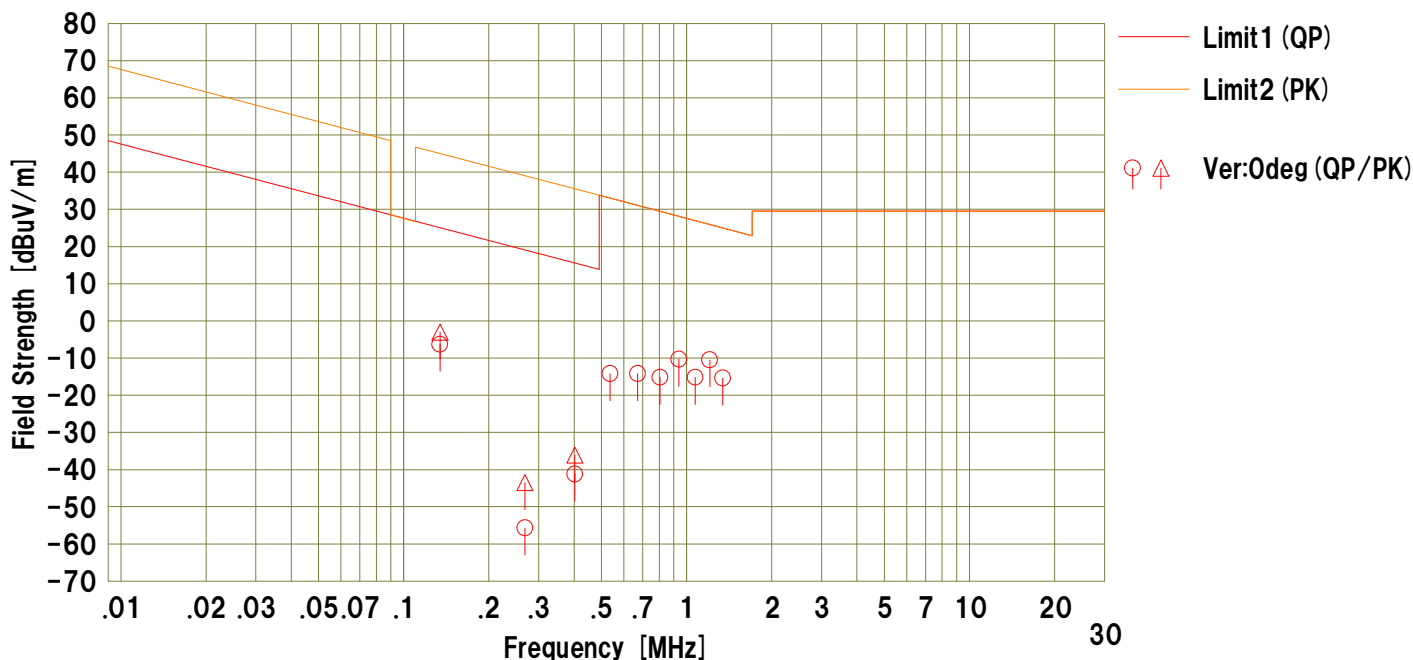

No.	Freq. [MHz]	Reading		Ant.Fac [dB/m]	Loss [dB]	Gain [dB]	Result		Limit		Margin		Antenna	Table [deg]	Comment
		<QP> [dBuV]	<PK> [dBuV]				<QP> [dBuV/m]	<PK> [dBuV/m]	<QP> [dBuV/m]	<PK> [dBuV/m]	<QP> [dB]	<PK> [dB]			
3	0.13420	80.0	83.3	19.5	-74.1	31.7	-6.3	-3.0	25.0	45.0	31.3	48.0	Ver:0deg	1	QP:Use d AV Detector
4	0.26840	30.8	43.0	19.5	-74.1	31.9	-55.7	-43.5	19.0	39.0	74.7	82.5	Ver:0deg	262	QP:Use d AV Detector
5	0.40260	45.3	50.4	19.5	-74.1	31.9	-41.2	-36.1	15.5	35.5	56.7	71.6	Ver:0deg	36	QP:Use d AV Detector
6	0.53680	32.3		19.5	-34.1	31.9	-14.2		33.0		47.2		Ver:0deg	2	
7	0.67100	32.3		19.5	-34.1	31.9	-14.2		31.0		45.2		Ver:0deg	31	
8	0.80520	31.3		19.5	-34.1	31.9	-15.2		29.4		44.6		Ver:0deg	270	
9	0.93940	36.1		19.5	-34.0	31.9	-10.3		28.1		38.4		Ver:0deg	37	
10	1.07360	31.2		19.5	-34.0	31.9	-15.2		26.9		42.1		Ver:0deg	266	
11	1.20780	35.9		19.5	-34.0	31.9	-10.5		25.9		36.4		Ver:0deg	38	
12	1.34200	31.0		19.5	-34.0	31.9	-15.4		24.9		40.3		Ver:0deg	359	

Calculation:Result [dBuV / m]=Reading [dBuV] +Ant.Fac [dB / m]+Loss (Cable+ATT+D.Factor) [dB] - Gain (AMP) [dB]

Ant.Type=LOOP:Loop Antenna

D.Factor (Distance Factor)

9kHz-490kHz : 40 x log (3m/300m)=-80dB, 490kHz-30MHz : 40 x log (3m/30m)=-40dB

DATA OF RADIATED EMISSION (below 30MHz) TEST

UL Japan,Inc. Shonan EMC Lab. No.2 Anechoic Chamber
 Date : 2013/11/26

Company : YAMAHA MOTOR ELECTRONICS CO., LTD Mode : Transmitting (134.2kHz)
 Kind of EUT : IMMOBILIZER Order No. : 10126812S
 Model No. : 5SL-00 Power : DC 12V
 Serial No. : 3Y0001B Temp./Humi. : 24deg.C. / 36%RH
 Remarks : Loop Antenna:Horizontal, EUT Axis:Z

Limit1 : FCC15.209 (a) 3m, 9-90kHz:AV, 110-490kHz:AV, other:QP
 Limit2 : FCC15.209 (a) 3m, 9-90kHz:PK, 110-490kHz:PK, Engineer : Akira Sato

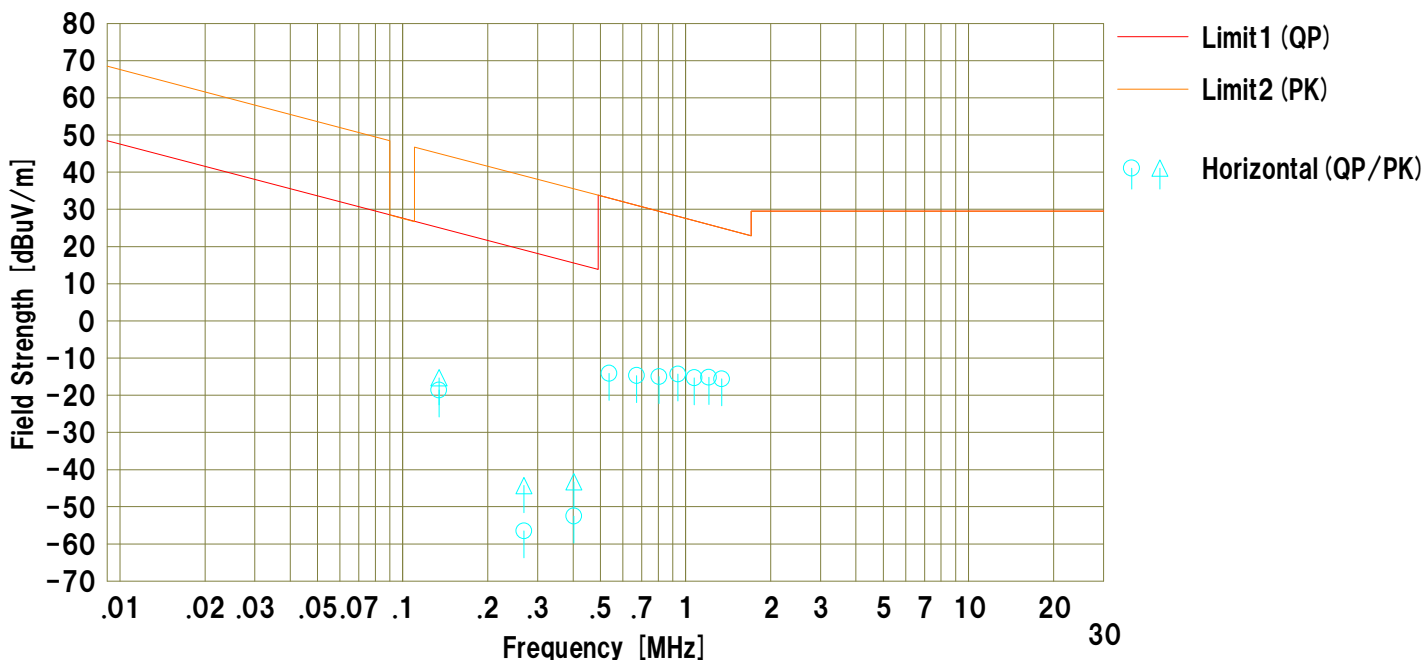

No.	Freq. [MHz]	Reading		Ant.Fac [dB/m]	Loss [dB]	Gain [dB]	Result		Limit		Margin		Antenna	Table [deg]	Comment
		<QP> [dBuV]	<PK> [dBuV]				<QP> [dBuV/m]	<PK> [dBuV/m]	<QP> [dBuV/m]	<PK> [dBuV/m]	<QP> [dB]	<PK> [dB]			
3	0.13420	67.7	71.0	19.5	-74.1	31.7	-18.6	-15.3	25.0	45.0	43.6	60.3	Horizontal	185	QP:Used AV Detector
4	0.26840	30.0	42.2	19.5	-74.1	31.9	-56.5	-44.3	19.0	39.0	75.5	83.3	Horizontal	358	QP:Used AV Detector
5	0.40260	34.0	43.2	19.5	-74.1	31.9	-52.5	-43.3	15.5	35.5	68.0	78.8	Horizontal	22	QP:Used AV Detector
6	0.53680	32.4		19.5	-34.1	31.9	-14.1		33.0		47.1		Horizontal	359	
7	0.67100	31.8		19.5	-34.1	31.9	-14.7		31.0		45.7		Horizontal	359	
8	0.80520	31.5		19.5	-34.1	31.9	-15.0		29.4		44.4		Horizontal	57	
9	0.93940	32.1		19.5	-34.0	31.9	-14.3		28.1		42.4		Horizontal	326	
10	1.07360	31.1		19.5	-34.0	31.9	-15.3		26.9		42.2		Horizontal	251	
11	1.20780	31.2		19.5	-34.0	31.9	-15.2		25.9		41.1		Horizontal	1	
12	1.34200	30.8		19.5	-34.0	31.9	-15.6		24.9		40.5		Horizontal	359	

DATA OF RADIATED EMISSION TEST

UL Japan, Inc. Shonan EMC Lab. No.2 Semi-Anechoic Chamber
Date : 2013/12/04

Company : YAMAHA MOTOR ELECTRONICS CO., LTD	Mode : Transmitting (134.2kHz)
Kind of EUT : IMMOBILIZER	Order No. : 10126812S
Model No. : 5SL-00	Power : DC 12V
Serial No. : 3Y0001B	Temp./Humi. : 23deg.C. / 35%RH
Remarks : EUT Axis:HOR_X, VER:Y	

Limit1 : FCC15.209 3m, below 1GHz:QP, above 1GHz:AV

Engineer : Akira Sato

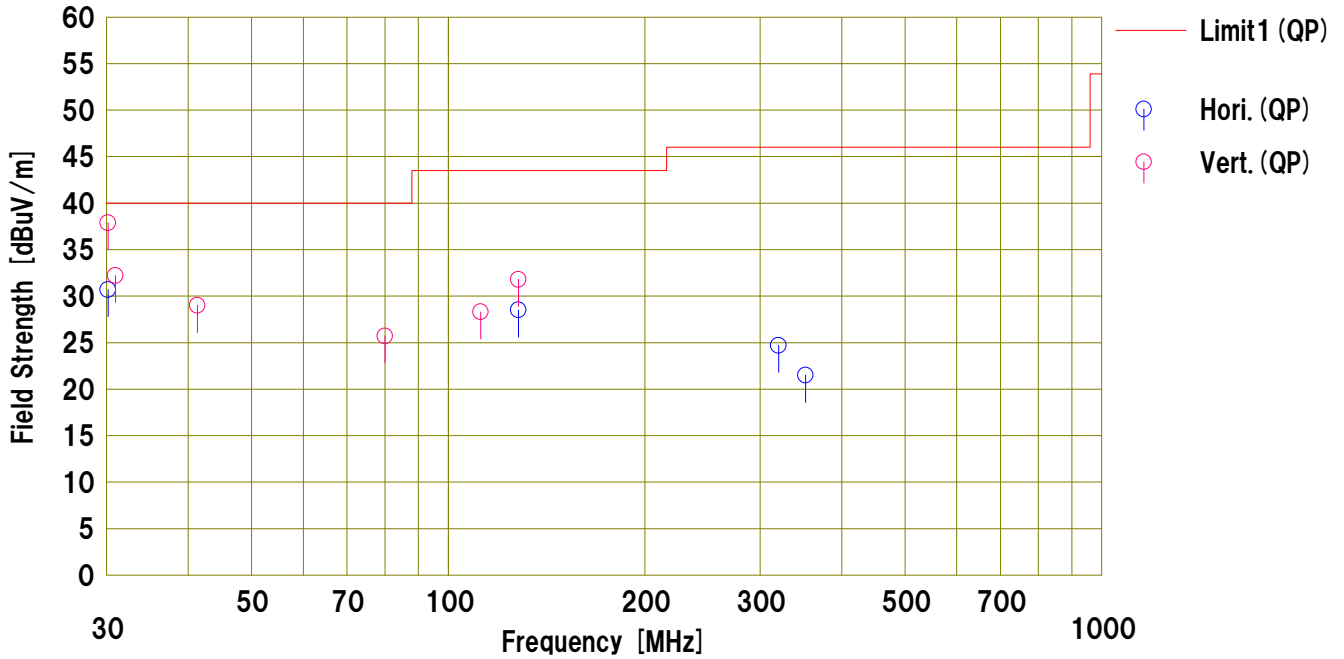

No.	Freq. [MHz]	Reading	Ant.Fac [dB/m]	Loss [dB]	Gain [dB]	S.Fac [dB]	Result	Limit	Margin	Pola. [H/V]	Height [cm]	Angle [deg]	Ant. Type	Comment
		<QP> [dBuV]					<QP> [dBuV/m]	<QP> [dB]						
1	30.149	38.0	17.7	7.0	31.9	-0.1	30.7	40.0	9.3	Hori.	317	211	BC	
2	128.109	38.4	13.6	8.4	31.8	-0.1	28.5	43.5	15.0	Hori.	254	329	BC	
3	320.269	34.6	14.3	7.5	31.7	0.0	24.7	46.0	21.3	Hori.	168	233	LP	
4	352.291	30.2	15.1	7.8	31.6	0.0	21.5	46.0	24.5	Hori.	131	43	LP	
5	30.142	45.2	17.7	7.0	31.9	-0.1	37.9	40.0	2.1	Vert.	100	104	BC	
6	30.947	39.8	17.4	7.0	31.9	-0.1	32.2	40.0	7.8	Vert.	100	104	BC	
7	41.314	39.8	13.9	7.2	31.9	0.0	29.0	40.0	11.0	Vert.	100	24	BC	
8	80.063	43.0	6.4	7.8	31.9	0.4	25.7	40.0	14.3	Vert.	112	176	BC	
9	112.087	40.2	11.9	8.2	31.8	-0.2	28.3	43.5	15.2	Vert.	100	185	BC	
10	128.109	41.7	13.6	8.4	31.8	-0.1	31.8	43.5	11.7	Vert.	100	36	BC	

Calculation:Result [dBuV/m] =Reading [dBuV] +Ant.Fac [dB/m] +Loss (Cable+ATT) [dB] +S.Fac (ΔAF) [dB] -Gain (AMP) [dB]
Ant.Type=BC:Biconical Antenna LP:Logperiodic Antenna SHA**: Horn

-26dB Bandwidth (FCC) / 99% Occupied Bandwidth

UL Japan, Inc. Shonan EMC No.2 Semi-Anechoic Chamber

COMPANY : YAMAHA MOTOR ELECTRONICS CO., LTD.
EQUIPMENT : IMMOBILIZER
MODEL NUMBER : 5SL-00
SERIAL NUMBER : 3Y0001B
POWER : DC12V
MODE : Transmitting (134.2kHz)

REPORT NO : 10126812S
REGULATION : (FCC) ANSI C63.4:2009, 13.7 (IC) RSS-Gen 4.6.1
DATE : November 26, 2013
TEMP/HUMI. : 24deg.C / 35%RH
ENGINEER : Akira Sato

-26dB Bandwidth [kHz]	99% Occupied Bandwidth [kHz]
19.334	19.2526

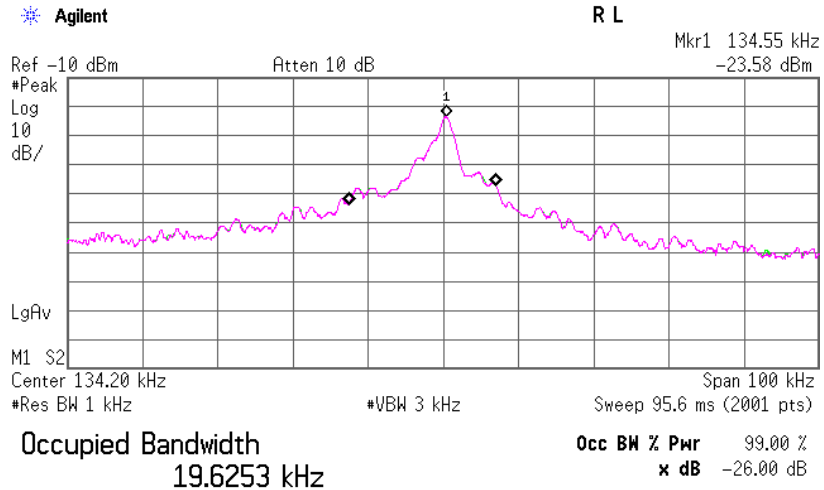

Transmit Freq Error -2.761 kHz
x dB Bandwidth 19.334 kHz
 (-26dB Bandwidth)

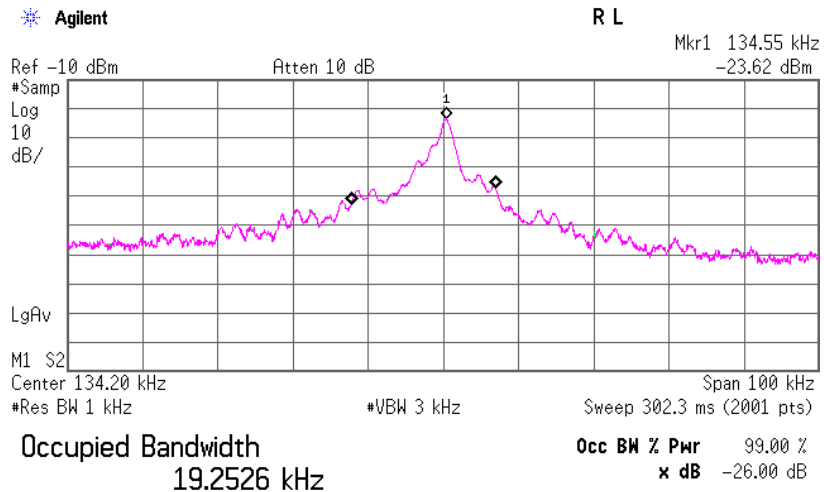

Transmit Freq Error -2.646 kHz
x dB Bandwidth 19.053 kHz*
 (99% Occupied Bandwidth)

APPENDIX 2 Test Instruments

EMI test equipment

Control No.	Instrument	Manufacturer	Model No	Serial No	Test Item	Calibration Date * Interval(month)
SAF-02	Pre Amplifier	SONOMA	310N	290212	RE	2013/02/12 * 12
SAT6-02	Attenuator	JFW	50HF-006N	-	RE	2013/02/12 * 12
KAT3-11	Attenuator	JFW IND. INC.	50HF-003N	-	RE	2013/08/19 * 12
SBA-02	Biconical Antenna	Schwarzbeck	BBA9106	91032665	RE	2012/11/18 * 12
SCC-B1/B3/B5/B7/B8/B13/SRSE-02	Coaxial Cable&RF Selector	Fujikura/Fujikura/Suhner/Suhner/Suhner/TOYO	8D2W/12DSFA/141PE/141PE/141PE/141PE/NS4906	-/0901-270(RF Selector)	RE	2013/04/03 * 12
SCC-B2/B4/B6/B7/B8/B13/SRSE-02	Coaxial Cable&RF Selector	Fujikura/Fujikura/Suhner/Suhner/Suhner/TOYO	8D2W/12DSFA/141PE/141PE/141PE/141PE/NS4906	-/0901-270(RF Selector)	RE	2013/04/03 * 12
SLA-02	Logperiodic Antenna	Schwarzbeck	UHALP9108A	UHALP 9108-A 0893	RE	2012/11/18 * 12
SOS-03	Humidity Indicator	A&D	AD-5681	4063325	RE	2013/02/27 * 12
STR-02	Test Receiver	Rohde & Schwarz	ESCI	100575	RE	2013/09/24 * 12
SJM-02	Measure	KOMELON	KMC-36	-	RE	-
SAEC-02(NSA)	Semi-Anechoic Chamber	TDK	SAEC-02(NSA)	2	RE	2013/07/06 * 12
COTS-SEMI-1	EMI Software	TSJ	TEPTO-DV(RE,CE,RF,MF)	-	RE	-
SAT6-07	Attenuator	JFW	50HF-006N	-	RE	2013/02/12 * 12
SLP-02	Loop Antenna	Rohde & Schwarz	HFH2-Z2	100218	RE	2013/11/08 * 12
SSA-02	Spectrum Analyzer	Agilent	E4448A	MY48250106	RE	2013/03/28 * 12

The expiration date of the calibration is the end of the expired month .
As for some calibrations performed after the tested dates , those test equipment have been controlled by means of an unbroken chains of calibrations .

All equipment is calibrated with valid calibrations . Each measurement data is traceable to the national or international standards .

Test Item :

RE: Radiated emission