



Part 15C

TEST REPORT

Product Name	Smart Terminal
Model Name	BN-HH-G03
Brand Name	Baynexus
FCC ID	2ABHWBN-HH-G03
Client	BayNexus Inc
Manufacturer	BayNexus Inc
Date of issue	September 23, 2015

TA Technology (Shanghai) Co., Ltd.

TA Technology (Shanghai) Co., Ltd.
Test Report

Report No.: RXA1507-0129RF01R2

Page 2 of 58

GENERAL SUMMARY

Reference Standard(s)	<p>FCC CFR47 Part 15C (2014) Radio Frequency Devices</p> <p>15.205 Restricted bands of operation;</p> <p>15.207 Conducted limits;</p> <p>15.209 Radiated emission limits; general requirements;</p> <p>15.247 Operation within the bands 902-928 MHz, 2400-2483.5 MHz, and 5725-5850MHz.</p> <p>ANSI C63.4 Methods of Measurement of Radio-Noise Emission from Low-Voltage Electrical and Electronic Equipment in the Range of 9 KHz to 40GHz. (2014)</p> <p>DA00-705 Filing and Frequency Measurement Guidelines For Frequency Hopping Spread Spectrum System.(2000)</p>
Conclusion	<p>This portable wireless equipment has been measured in all cases requested by the relevant standards. Test results in Chapter 2 of this test report are below limits specified in the relevant standards.</p> <p>General Judgment: Pass</p>
Comment	<p>The test result only responds to the measured sample.</p>

Approved by 
Kai Xu
Director

Revised by 
Lingling Kang
RF Manager

Performed by 
Peng Tao
RF Engineer

TABLE OF CONTENT

1. General Information	4
1.1. Notes of the test report.....	4
1.2. Testing laboratory	5
1.3. Applicant Information	5
1.4. Manufacturer Information.....	5
1.5. Information of EUT	6
1.6. Test Date	6
2. Test Information	7
2.1. Information about the FHSS characteristics.....	7
2.1.1. Pseudorandom Frequency Hopping Sequence	7
2.1.2. Equal Hopping Frequency Use	7
2.1.3. System Receiver Input Bandwidth	7
2.2. FCC Part 15.247, sections (g) and (h)	8
2.3. Test Mode	8
2.4. Summary of test results	9
2.5. Peak Power Output –Conducted.....	10
2.6. Occupied Bandwidth (20dB)	13
2.7. Frequency Separation.....	16
2.8. Time of Occupancy (Dwell Time)	19
2.9. Band Edge Compliance	21
2.10. Spurious Radiated Emissions in the Restricted Band.....	24
2.11. Number of hopping Frequency	27
2.12. Spurious RF Conducted Emissions.....	29
2.13. Radiates Emission.....	33
2.14. AC Power Line Conducted Emission.....	48
3. Main Test Instruments.....	55
ANNEX A: EUT Appearance and Test Setup.....	56
A.1 EUT Appearance.....	56
A.2 Test Setup.....	57

1. General Information

1.1. Notes of the test report

TA Technology (Shanghai) Co., Ltd. has obtained the accreditation of China National Accreditation Service for Conformity Assessment (CNAS), and accreditation number: L2264.

TA Technology (Shanghai) Co., Ltd. has been listed on the US Federal Communications Commission list of test facilities recognized to perform electromagnetic emissions measurements. The site recognition number is 428261.

TA Technology (Shanghai) Co., Ltd. has been listed by industry Canada to perform electromagnetic emission measurement. The site recognition number is 8510A.

TA Technology (Shanghai) Co., Ltd. guarantees the reliability of the data presented in this test report, which is the results of measurements and tests performed for the items under test on the date and under the conditions stated in this test report and is based on the knowledge and technical facilities available at TA Technology (Shanghai) Co., Ltd. at the time of execution of the test.

TA Technology (Shanghai) Co., Ltd. is liable to the client for the maintenance by its personnel of the confidentiality of all information related to the items under test and the results of the test. This report only refers to the item that has undergone the test.

The test results in this test report relate only to the devices specified in this report. This report shall not be reproduced except in full without the written approval of **TA Technology (Shanghai) Co., Ltd.**

If the electronic report is inconsistent with the printed one, it should be subject to the latter.

TA Technology (Shanghai) Co., Ltd. Test Report

Report No.: RXA1507-0129RF01R2

Page 5 of 58

1.2. Testing laboratory

Company: TA Technology (Shanghai) Co., Ltd.
Address: No.145, Jintang Rd, Tangzhen Industry Park, Pudong
City: Shanghai
Post code: 201201
Country: P. R. China
Contact: Xu Kai
Telephone: +86-021-50791141/2/3
Fax: +86-021-50791141/2/3-8000
Website: <http://www.ta-shanghai.com>
E-mail: xukai@ta-shanghai.com

1.3. Applicant Information

Company: BayNexus Inc
Address: B307,530 Building TaiHu International Science park Wu XI
China

1.4. Manufacturer Information

Company: BayNexus Inc
Address: B307,530 Building TaiHu International Science park Wu XI
China

1.5. Information of EUT

General information

Name of EUT:	Smart terminal
IMEI:	863930021086487
Hardware Version:	S80-V31
Software Version:	90 0C 00 00 00 00 07
Antenna Type:	Internal Antenna
Device Operating Configurations:	
Modulation Type:	Frequency Hopping Spread Spectrum (FHSS)
	DSB-ASK;
Max. Conducted Power	9.522dBm
Power Supply:	Battery or Adapter
Operating Frequency Range(s)	902-928MHz

Auxiliary equipment details

AE1: Battery

Model: G3

Manufacturer: ShenZhen FREE Technology co., Ltd

S/N: 624053P

1.6. Test Date

The test is performed from August 20, 2015 to September 11, 2015.

2. Test Information

2.1. Information about the FHSS characteristics

2.1.1. Pseudorandom Frequency Hopping Sequence

Frequency Hopping Systems. A spread spectrum system in which the carrier is modulated with the coded information in a conventional manner causing a conventional spreading of the RF energy about the frequency carrier. The frequency of the carrier is not fixed but changes at fixed intervals under the direction of a coded sequence. The wide RF bandwidth needed by such a system is not required by spreading of the RF energy about the carrier but rather to accommodate the range of frequencies to which the carrier frequency can hop. The test of a frequency hopping system is that the near term distribution of hops appears random, the long term distribution appears evenly distributed over the hop set, and sequential hops are randomly distributed in both direction and magnitude of change in the hop set.

The selection scheme chooses a segment of 25 hop frequencies spanning about 26 MHz and visits these hops in a pseudo-random order. Next, a different 25-hop segment is chosen, etc. In the page, master page response, slave page response, page scan, inquiry, inquiry response and inquiry scan hopping sequences, the same 25-hop segment is used all the time (the segment is selected by the address; different devices will have different paging segments).

When the basic channel hopping sequence is selected, the output constitutes a pseudo-random sequence that slides through the 50 hops. Each frequency used equally on the average by each transmitter.

The system receiver have input bandwidths that match the hopping channel bandwidths of their corresponding transmitters and shift frequencies in synchronization with the transmitted signals.

2.1.2. Equal Hopping Frequency Use

All RFID units following the EPC Gen2 specification are time and hop-synchronized to the channel. Each new transmission event begins on the next channel in the hopping sequence after the final channel used in the previous transmission event.

2.1.3. System Receiver Input Bandwidth

Each channel bandwidth is 500kHz. The system receivers have input bandwidths that match the hopping channel bandwidths of their corresponding transmitters and shift frequencies in synchronization with the transmitted signals.

2.2. FCC Part 15.247, sections (g) and (h)

This EUT complies with FCC Part 15.247, sections (g) and (h) as listed below.

(g) Frequency hopping spread spectrum systems are not required to employ all available hopping channels during each transmission. However, the system, consisting of both the transmitter and the receiver, must be designed to comply with all of the regulations in this section should the transmitter be presented with a continuous data (or information) stream. In addition, a system employing short transmission bursts must comply with the definition of a frequency hopping system and must distribute its transmissions over the minimum number of hopping channels specified in this section.

(h) The incorporation of intelligence within a frequency hopping spread spectrum system that permits the system to recognize other users within the spectrum band so that it individually and independently chooses and adapts its hopsets to avoid hopping on occupied channels is permitted. The coordination of frequency hopping systems in any other manner for the express purpose of avoiding the simultaneous occupancy of individual hopping frequencies by multiple transmitters is not permitted.

2.3. Test Mode

During the process of the testing, The EUT is controlled by the Base Station Simulator to ensure max power transmission and proper modulation.

EUT is stand-up position (Z axis), lie-down position (X, Y axis). The worst emission was found in stand-up position (Z axis) and the worst case was recorded. Then this mode was measured in the following mode: EUT with cradle and EUT without cradle. The worst emission was found in EUT with cradle mode and the worst case was recorded.

Test Modes		
Band	Radiated Test Cases	Conducted Test Cases
RFID(902-928MHz)	DSB-ASK (902.75MHz/915 MHz /927.25 MHz)	DSB-ASK (902.75MHz/915 MHz /927.25 MHz)

TA Technology (Shanghai) Co., Ltd.
Test Report

Report No.: RXA1507-0129RF01R2

Page 9 of 58

2.4. Summary of test results

Number	Summary of measurements of results	Clause in FCC rules	Verdict
1	Peak Power Output -Conducted	15.247(b)(3)	PASS
2	Occupied Bandwidth (20dB)	15.247(a)(1)	PASS
3	Frequency Separation	15.247(a)(1)	PASS
4	Time of Occupancy (Dwell Time)	15.247(a)(1)(iii)	PASS
5	Band Edge Compliance	15.247(d)	PASS
6	Spurious Radiated Emissions in the restricted band	15.247(d),15.205,15.209	PASS
7	Number of Hopping Frequency	15.247(a)(1)(iii)	PASS
8	Spurious RF Conducted Emissions	15.247(d)	PASS
9	Radiates Emission	15.247(d),15.205,15.209	PASS
10	AC Power Line Conducted Emission	15.207	PASS

2.5. Peak Power Output –Conducted

Ambient condition

Temperature	Relative humidity	Pressure
23°C ~25°C	45%~50%	101.5kPa

Methods of Measurement

During the process of the testing, The EUT was connected to the Spectrum Analyzer through an external attenuator and a known loss cable. The EUT is max power transmission with proper modulation. We use DA00-705 for this test.

These measurements have been tested at following frequency: 902.75MHz, 915MHz, and 927.25MHz.

Test Setup

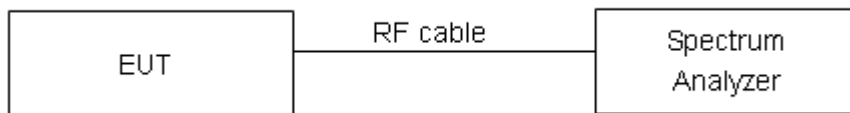

Limits

Rule Part 15.247 (b) (3) specifies that " For systems using digital modulation in the 902–928 MHz, 2400–2483.5 MHz, and 5725–5850 MHz bands: 1 Watt."

Peak Output Power	$\leq 1W$ (30dBm)
-------------------	-------------------

Measurement Uncertainty

The assessed measurement uncertainty to ensure 95% confidence level for the normal distribution is with the coverage factor $k = 2$, $U = 0.44$ dB.

TA Technology (Shanghai) Co., Ltd. Test Report

Report No.: RXA1507-0129RF01R2

Page 11 of 58

Test Results

Frequency (MHz)	Peak Output Power (dBm)	Conclusion
902.75	9.522	PASS
915	9.443	PASS
927.25	9.202	PASS

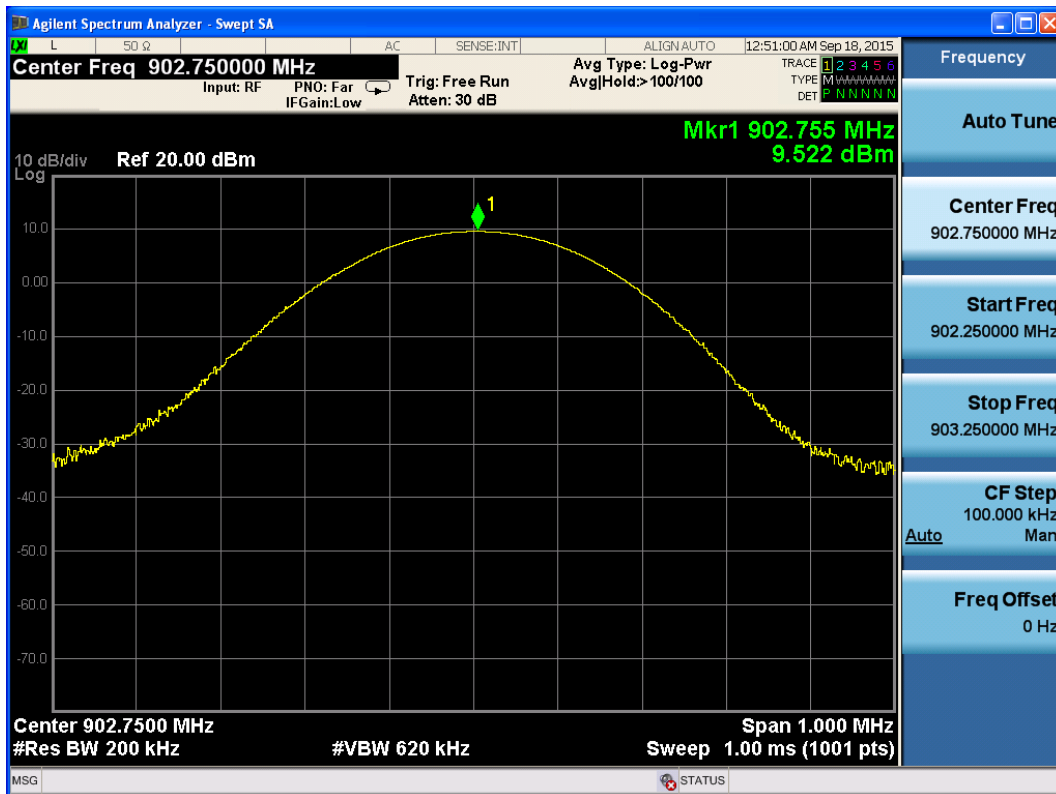

Carrier frequency (MHz): 902.75

TA Technology (Shanghai) Co., Ltd. Test Report

Report No.: RXA1507-0129RF01R2

Page 12of 58

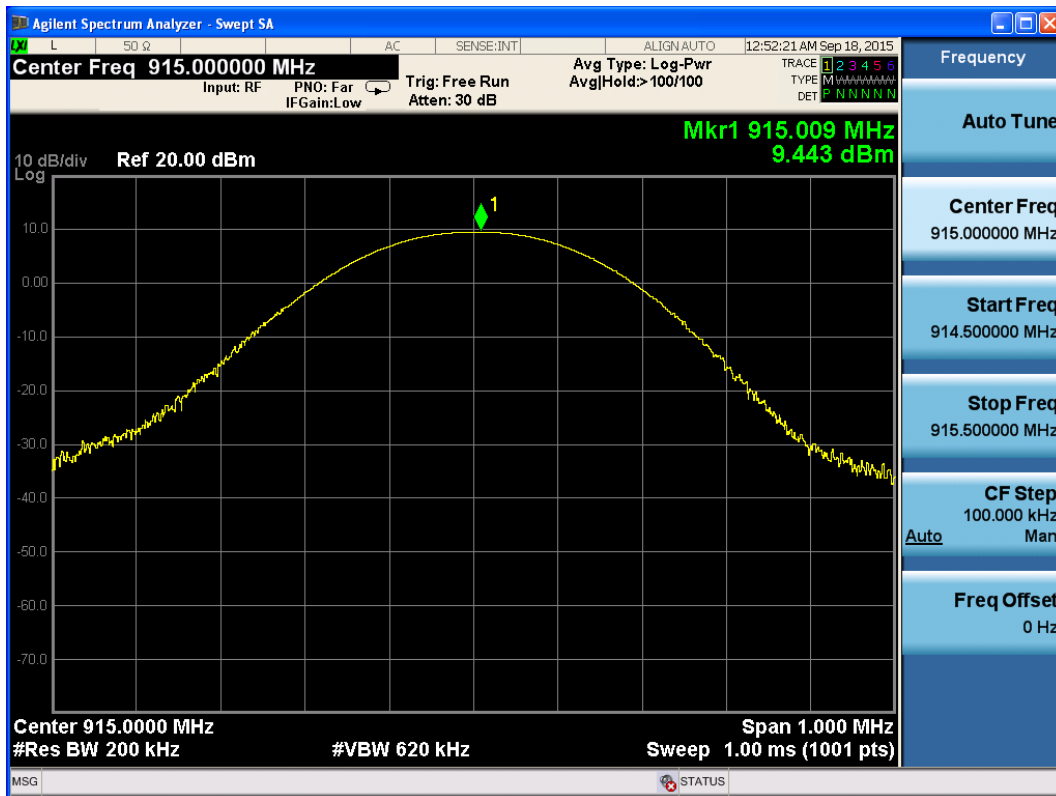

Carrier frequency (MHz): 915

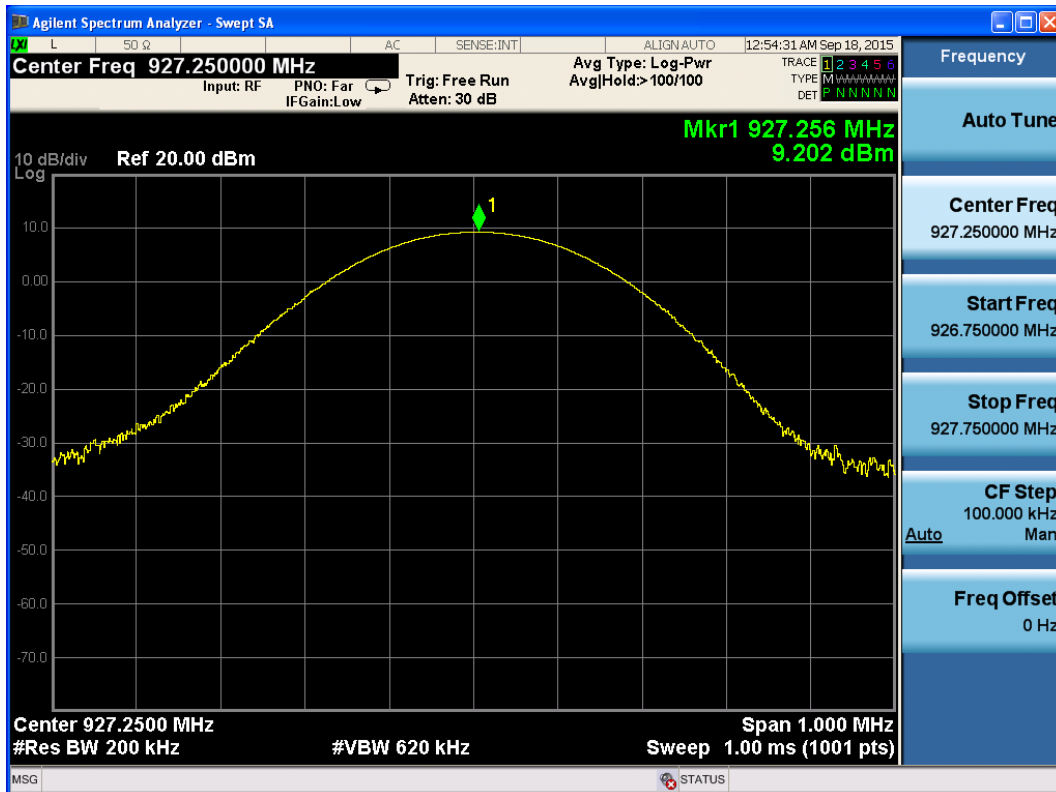

Carrier frequency (MHz): 927.25

2.6. Occupied Bandwidth (20dB)

Ambient condition

Temperature	Relative humidity	Pressure
23°C ~25°C	45%~50%	101.5kPa

Method of Measurement

The EUT was connected to the spectrum analyzer through an external attenuator (20dB) and a known loss cable. RBW is set to 2 kHz; VBW is set to 6.2 kHz on spectrum analyzer. -20dB occupied bandwidths are recorded.

Test Setup

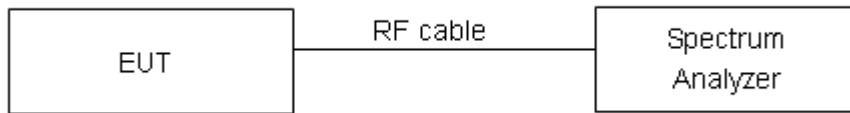

Limits

Rule Part 15.247(a)(1) specifies that "For frequency hopping systems operating in the 902-928 MHz band, the maximum allowed 20 dB bandwidth of the hopping channel is 500 kHz. "

Measurement Uncertainty

The assessed measurement uncertainty to ensure 95% confidence level for the normal distribution is with the coverage factor $k = 2$, $U = 936$ Hz.

TA Technology (Shanghai) Co., Ltd. Test Report

Report No.: RXA1507-0129RF01R2

Page 14of 58

Test Results

Frequency (MHz)	20dB Bandwidth (kHz)	Conclusion
902.75	83.31	Pass
915	83.30	Pass
927.25	82.56	Pass

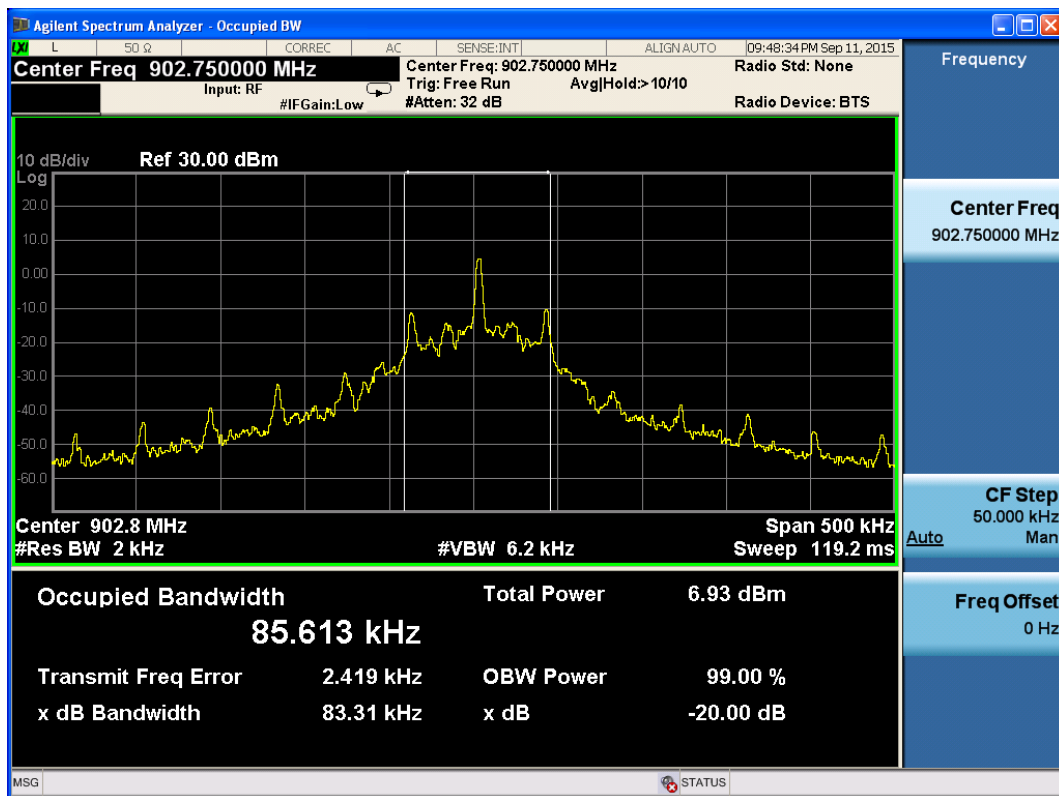

Carrier frequency (MHz): 902.75

TA Technology (Shanghai) Co., Ltd. Test Report

Report No.: RXA1507-0129RF01R2

Page 15of 58

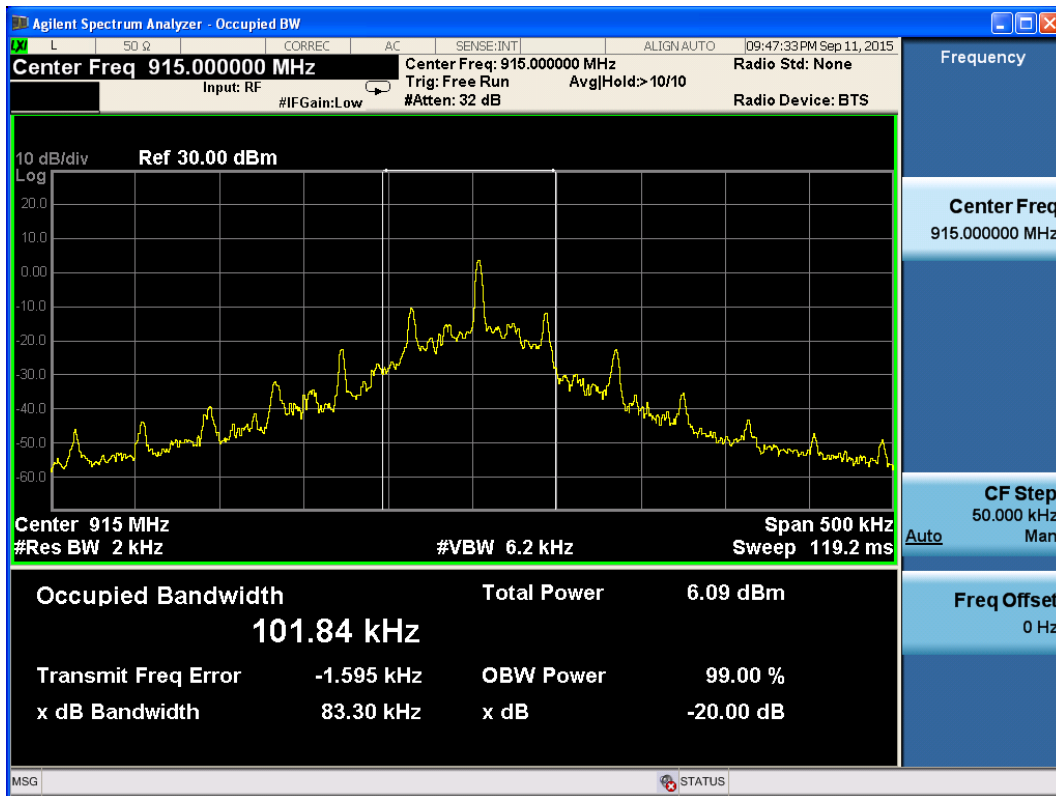

Carrier frequency (MHz): 915

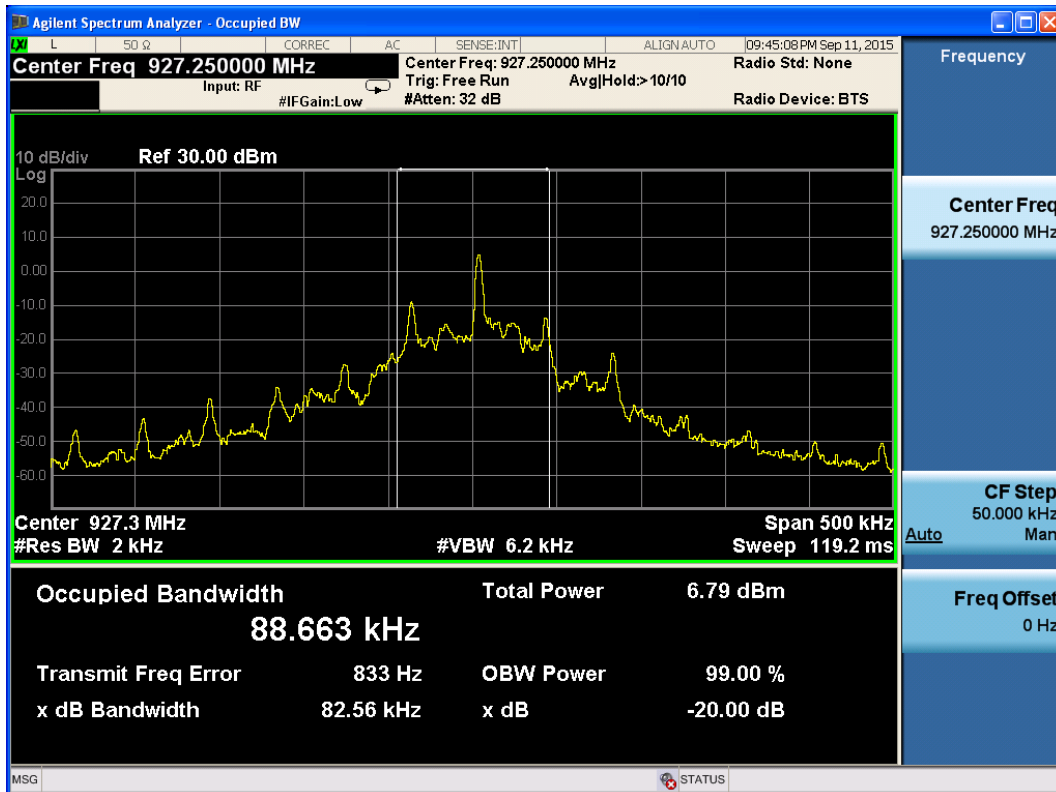

Carrier frequency (MHz): 927.25

2.7. Frequency Separation

Ambient condition

Temperature	Relative humidity	Pressure
23°C ~25°C	45%~50%	101.5kPa

Method of Measurement

The EUT was connected to the spectrum analyzer with a known loss. RBW is set to 150 kHz and VBW is set to 300 kHz on spectrum analyzer. Set EUT on Hopping on mode.

Test setup

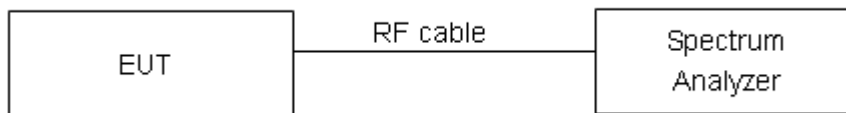

Limits

Rule Part 15.247(a)(1) specifies that "Frequency hopping systems shall have hopping channel carrier frequencies separated by a minimum of 25 kHz or the 20 dB bandwidth of the hopping channel, whichever is greater."

Measurement Uncertainty

The assessed measurement uncertainty to ensure 95% confidence level for the normal distribution is with the coverage factor $k = 2$, $U = 936$ Hz.

TA Technology (Shanghai) Co., Ltd. Test Report

Report No.: RXA1507-0129RF01R2

Page 17 of 58

Test Results:

Carrier frequency (MHz)	Carrier frequency separation(kHz)	Limit(kHz)	Conclusion
902.75	504	121.668	PASS
915	498	122.592	PASS
927.25	498	123.213	PASS

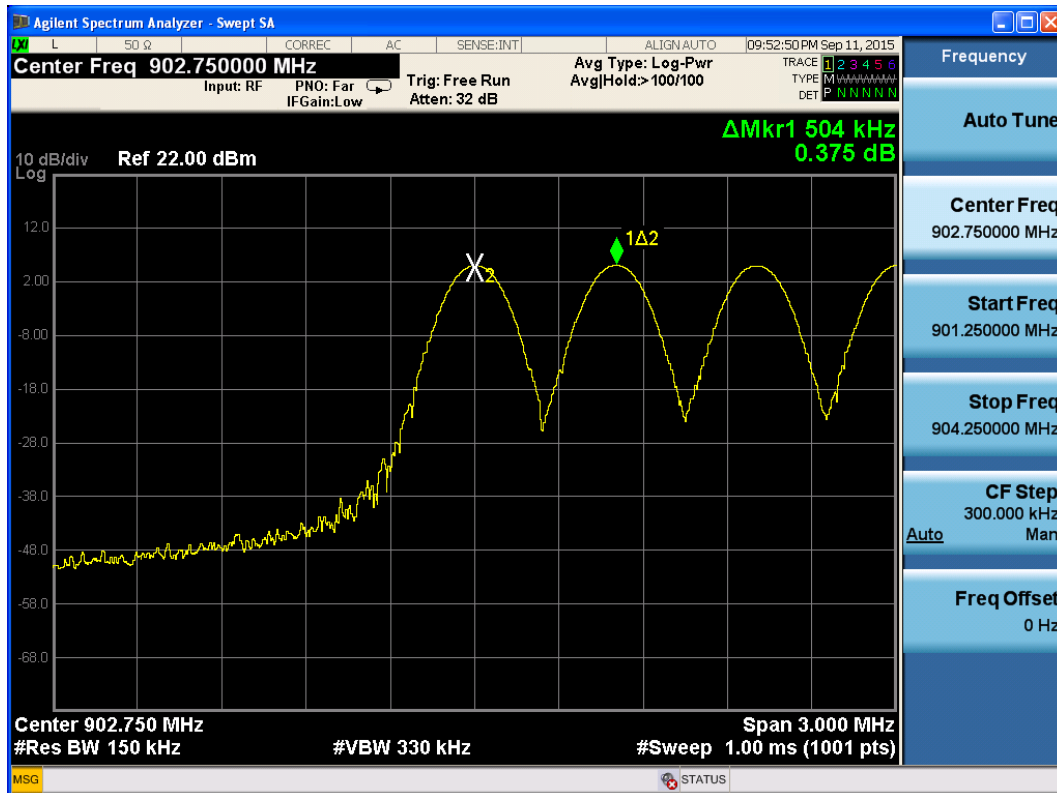

Carrier frequency (MHz): 902.75

TA Technology (Shanghai) Co., Ltd. Test Report

Report No.: RXA1507-0129RF01R2

Page 18of 58

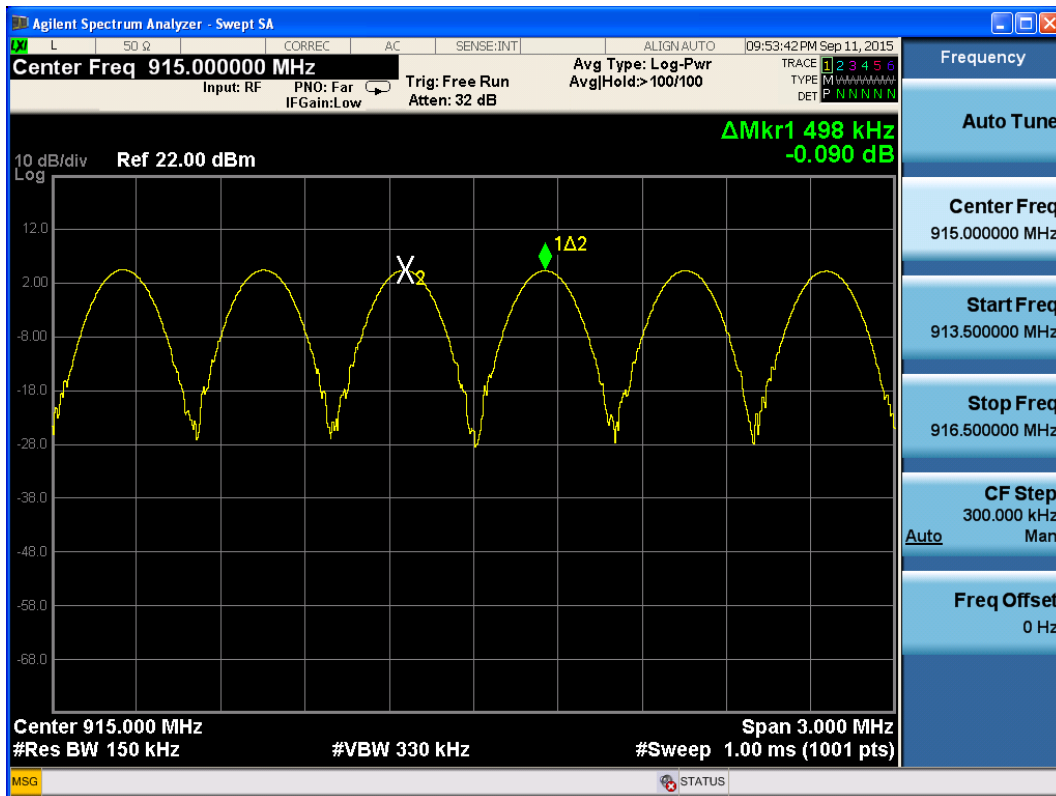

Carrier frequency (MHz): 915

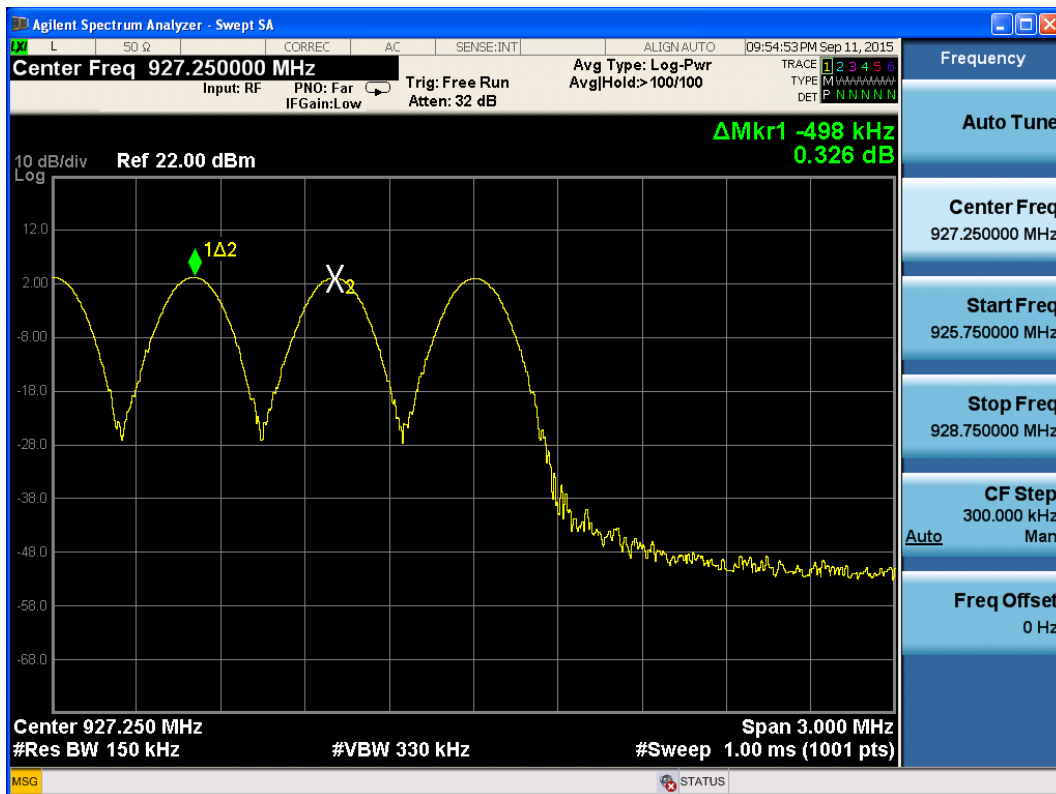

Carrier frequency (MHz): 927.25

2.8. Time of Occupancy (Dwell Time)

Ambient condition

Temperature	Relative humidity	Pressure
23°C ~25°C	45%~50%	101.5kPa

Methods of Measurement

The EUT was connected to the spectrum analyzer with a known loss. RBW is set to 10 kHz and VBW is set to 100 kHz on spectrum analyzer. The dwell time is calculated by:

Dwell time = time slot length * hop rate * 0.4s with:

Test Setup

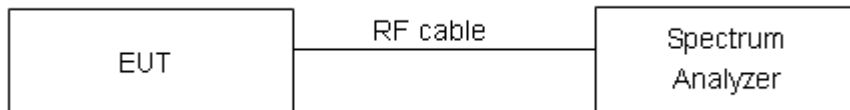

Limits

Rule Part 15.247(a)(1)(i) specifies that " frequency hopping systems operating in the 902-928 MHz band: if the 20 dB bandwidth of the hopping channel is less than 250 kHz, the system shall use at least 50 hopping frequencies and the average time of occupancy on any frequency shall not be greater than 0.4 seconds within a 20 second period."

Dwell time	$\leq 400\text{ms}$
------------	---------------------

Measurement Uncertainty

The assessed measurement uncertainty to ensure 95% confidence level for the normal distribution is with the coverage factor $k = 2$.

Requirements	Uncertainty
Dwell Time	$U = 0.64\text{ms}$

TA Technology (Shanghai) Co., Ltd. Test Report

Report No.: RXA1507-0129RF01R2

Page 20 of 58

Test Results:

hop rate (1/s)	Time slot length(ms)	Dwell time (ms)	Limit (ms)	Conclusion
159	5.320	338.352	400	PASS

Note: Dwell time = time slot length * hop rate * 0.4s



Carrier frequency (MHz): 915

2.9. Band Edge Compliance

Ambient condition

Temperature	Relative humidity	Pressure
23°C ~25°C	45%~50%	101.5kPa

Method of Measurement

The EUT was connected to the spectrum analyzer with a known loss. The lowest and highest channels were measured. The peak detector is used. RBW is set to 150 kHz and VBW is set to 430 kHz on spectrum analyzer. EUT test for Hopping Off mode.

Test Setup

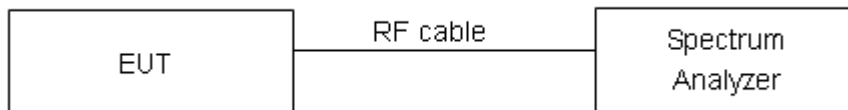

Limits

Rule Part 15.247(d) specifies that “In any 100 kHz bandwidth outside the frequency band in which the spread spectrum or digitally modulated intentional radiator is operating, the radio frequency power that is produced by the intentional radiator shall be at least 20 dB below that in the 100 kHz bandwidth within the band that contains the highest level of the desired power, based on either an RF conducted or a radiated measurement, provided the transmitter demonstrates compliance with the peak conducted power limits.”

Measurement Uncertainty

The assessed measurement uncertainty to ensure 95% confidence level for the normal distribution is with the coverage factor $k = 1.96$.

Frequency	Uncertainty
902 MHz - 928 MHz	1.407 dB

TA Technology (Shanghai) Co., Ltd. Test Report

Report No.: RXA1507-0129RF01R2

Page 22of 58

Test Results: PASS

Hopping Off-902.75 MHz

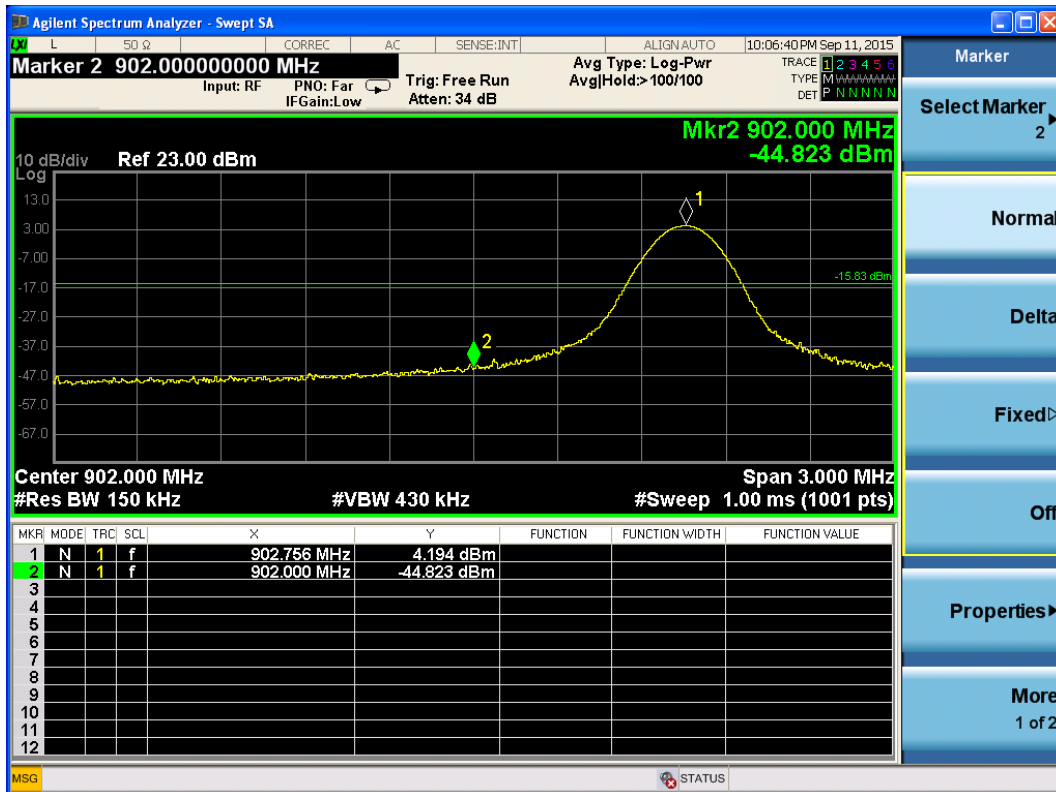

Carrier frequency (MHz): 902.75

Hopping Off-927.25 MHz

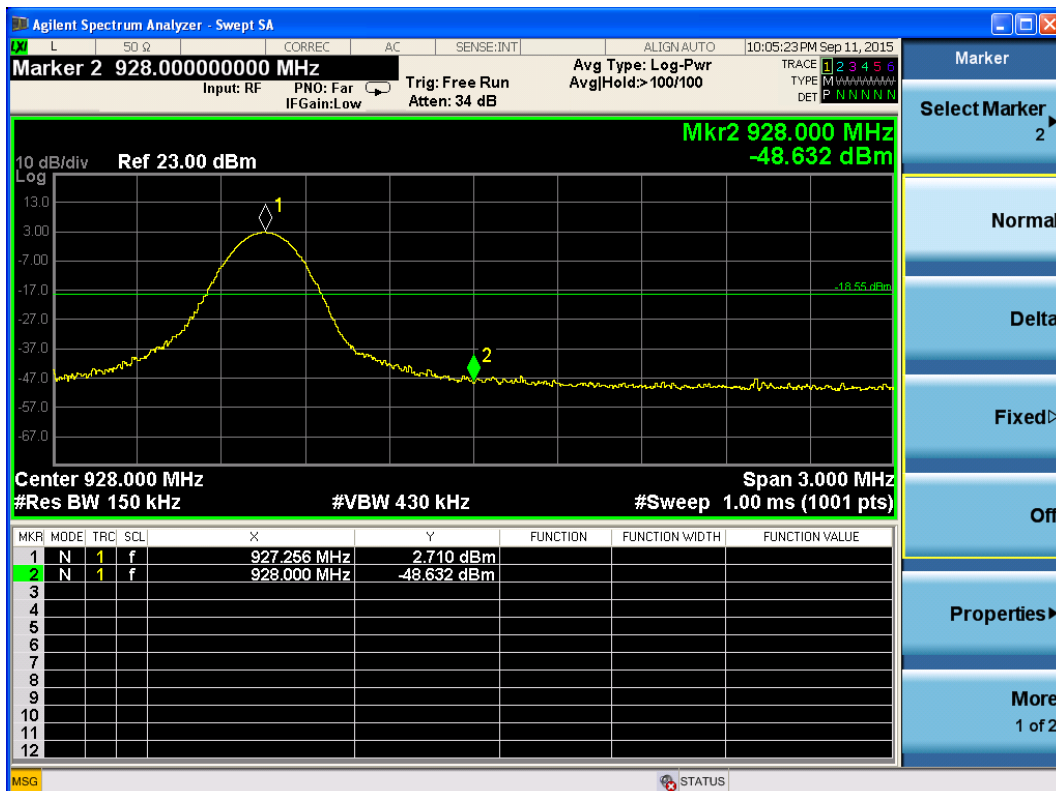

Carrier frequency (MHz): 927.25

TA Technology (Shanghai) Co., Ltd. Test Report

Report No.: RXA1507-0129RF01R2

Page 23of 58

Hopping On-902.75 MHz

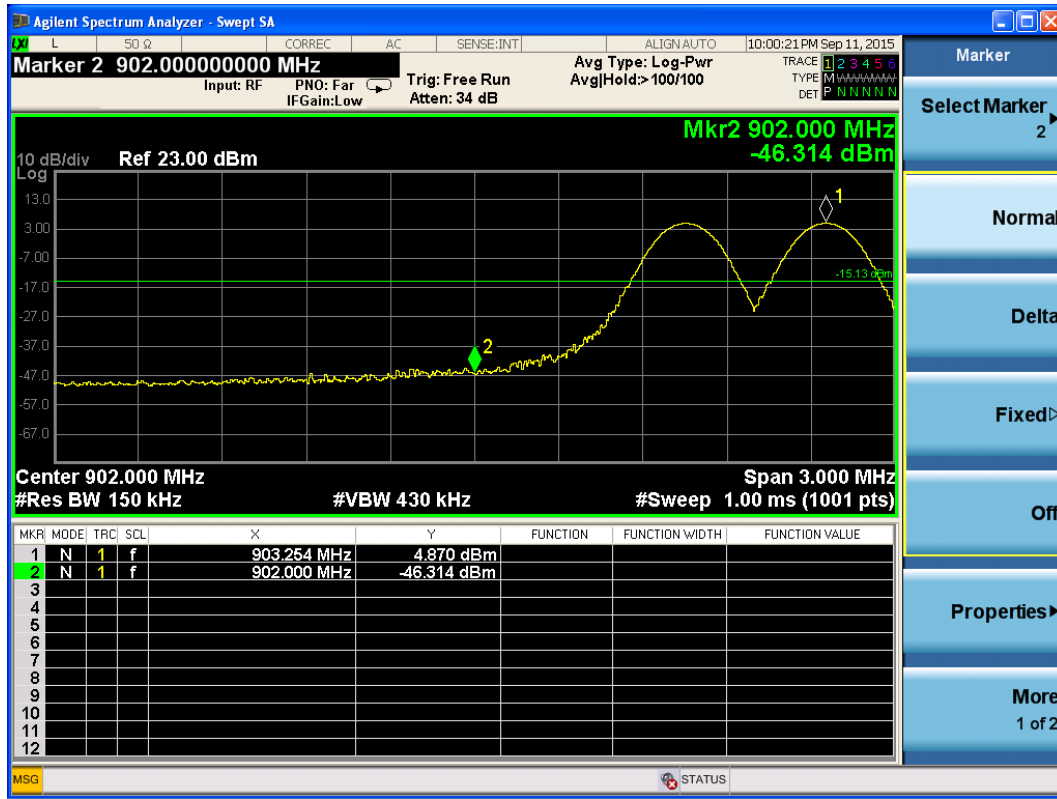

Carrier frequency (MHz): 902.75

Hopping On-927.25 MHz

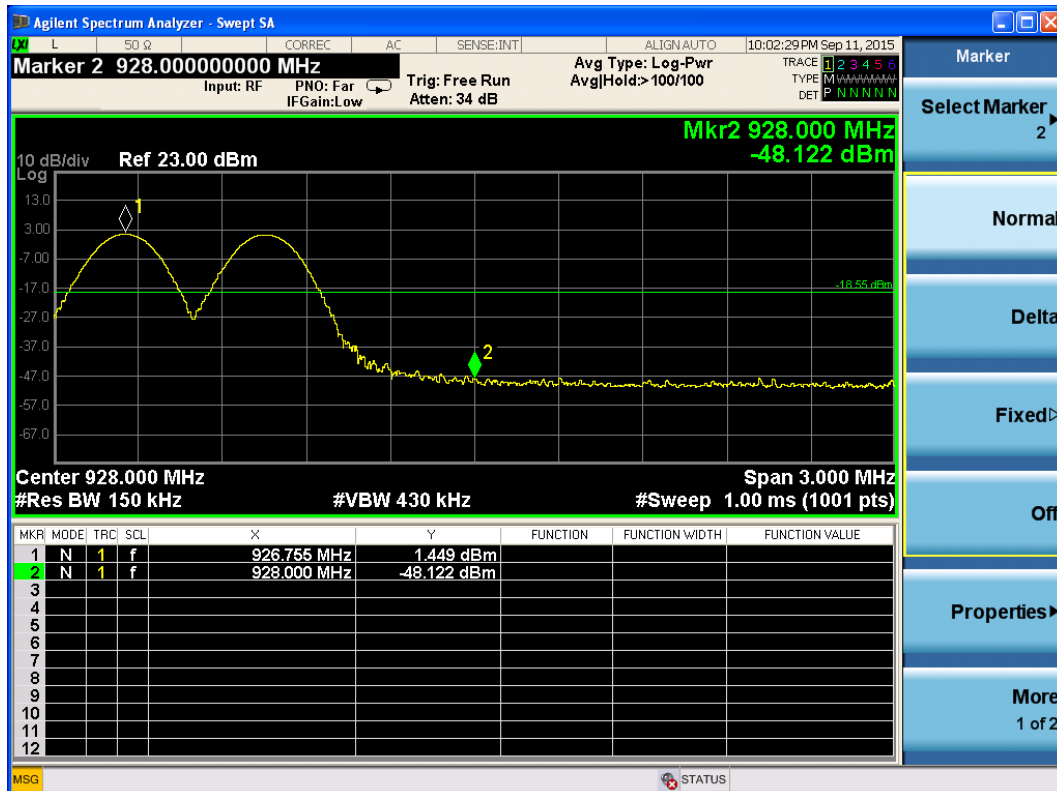

Carrier frequency (MHz): 927.25

2.10. Spurious Radiated Emissions in the Restricted Band

Ambient condition

Temperature	Relative humidity	Pressure
23°C ~25°C	45%~50%	101.5kPa

The Equipment Under Test (EUT) was set up on a non-conductive table in the semi-anechoic chamber. The test was performed at the distance of 3 m between the EUT and the receiving antenna. The turntable shall be rotated from 0 to 360 degrees for detecting the maximum of radiated spurious signal level. The measurements shall be repeated with orthogonal polarization of the test antenna. The data of cable loss and antenna factor has been calibrated in full testing frequency range before the testing.

Set the spectrum analyzer in the following:

(a) PEAK: RBW=VBW=1MHz / Sweep=AUTO

(b) The dwell time per channel of the hopping signal is less than 100 ms, then the reading obtained with the 10 Hz VBW may be further adjusted by a “duty cycle correction factor”, derived from $20\log(\text{dwell time}/100 \text{ ms})$, in an effort to demonstrate compliance with the 15.209 limit.

If the emission is pulsed, modify the unit for continuous operation; use the settings shown above, then correct the reading by subtracting the peak- average correction factor, derived from the appropriate duty cycle calculation.

This setting method can refer to DA00-705.

The data should not be further adjusted by a “duty cycle correction factor”, because The dwell time per channel of the hopping signal is more than 100 ms.

The test is in transmitting mode. The field strength of spurious emission was measured in the following position: EUT stand-up position (Z axis), lie-down position (X, Y axis) and docking mode. The worst emission was found in stand-up position (Y axis) and the worst case was recorded.

Test setup

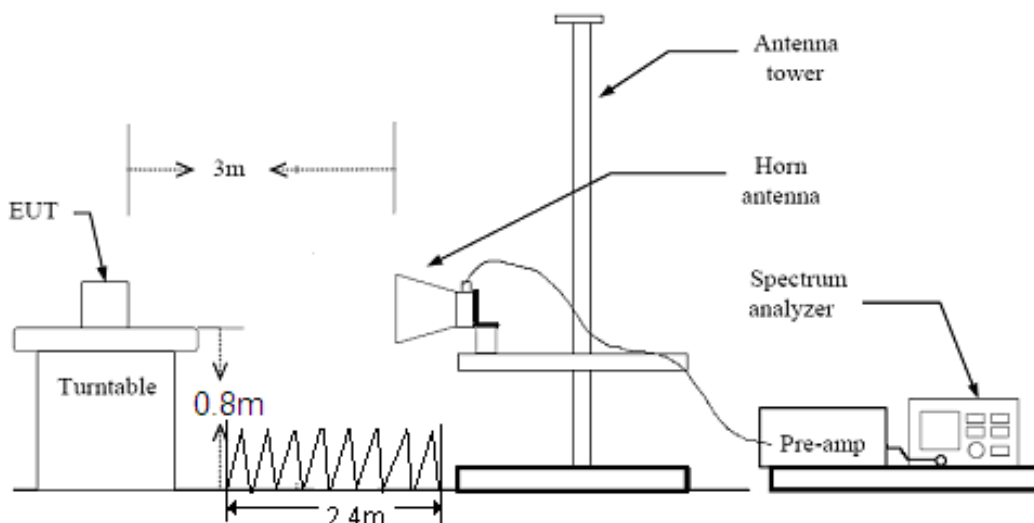

Note: Area side:2.4mX3.6m

TA Technology (Shanghai) Co., Ltd. Test Report

Limits

Spurious Radiated Emissions are permitted in any of the frequency bands listed below:

MHz	MHz	MHz	GHz
0.090 - 0.110	16.42 - 16.423	399.9 - 410	4.5 - 5.15
¹ 0.495 - 0.505	16.69475 - 16.69525	608 - 614	5.35 - 5.46
2.1735 - 2.1905	16.80425 - 16.80475	960 - 1240	7.25 - 7.75
4.125 - 4.128	25.5 - 25.67	1300 - 1427	8.025 - 8.5
4.17725 - 4.17775	37.5 - 38.25	1435 - 1626.5	9.0 - 9.2
4.20725 - 4.20775	73 - 74.6	1645.5 - 1646.5	9.3 - 9.5
6.215 - 6.218	74.8 - 75.2	1660 - 1710	10.6 - 12.7
6.26775 - 6.26825	108 - 121.94	1718.8 - 1722.2	13.25 - 13.4
6.31175 - 6.31225	123 - 138	2200 - 2300	14.47 - 14.5
8.291 - 8.294	149.9 - 150.05	2310 - 2390	15.35 - 16.2
8.362 - 8.366	156.52475 - 156.52525	2483.5 - 2500	17.7 - 21.4
8.37625 - 8.38675	156.7 - 156.9	2690 - 2900	22.01 - 23.12
8.41425 - 8.41475	162.0125 - 167.17	3260 - 3267	23.6 - 24.0
12.29 - 12.293	167.72 - 173.2	3332 - 3339	31.2 - 31.8
12.51975 - 12.52025	240 - 285	3345.8 - 3358	36.43 - 36.5
12.57675 - 12.57725	322 - 335.4	3600 - 4400	(²)
13.36 - 13.41			

Limit in restricted band

Frequency of emission (MHz)	Field strength(uV/m)	Field strength(dBuV/m)
30-88	100	40
88-216	150	43.5
216-960	200	46
Above960	500	54

§15.35(b)

There is also a limit on the radio frequency emissions, as measured using instrumentation with a peak detector function, corresponding to 20 dB above the maximum permitted average limit.

Peak Limit=74 dBuV/m

Average Limit=54 dBuV/m

Measurement Uncertainty

The assessed measurement uncertainty to ensure 95% confidence level for the normal distribution is with the coverage factor $k = 1.96$, $U = 3.55$ dB.

TA Technology (Shanghai) Co., Ltd. Test Report

Report No.: RXA1507-0129RF01R2

Page 26of 58

Test Results: 902.75MHz

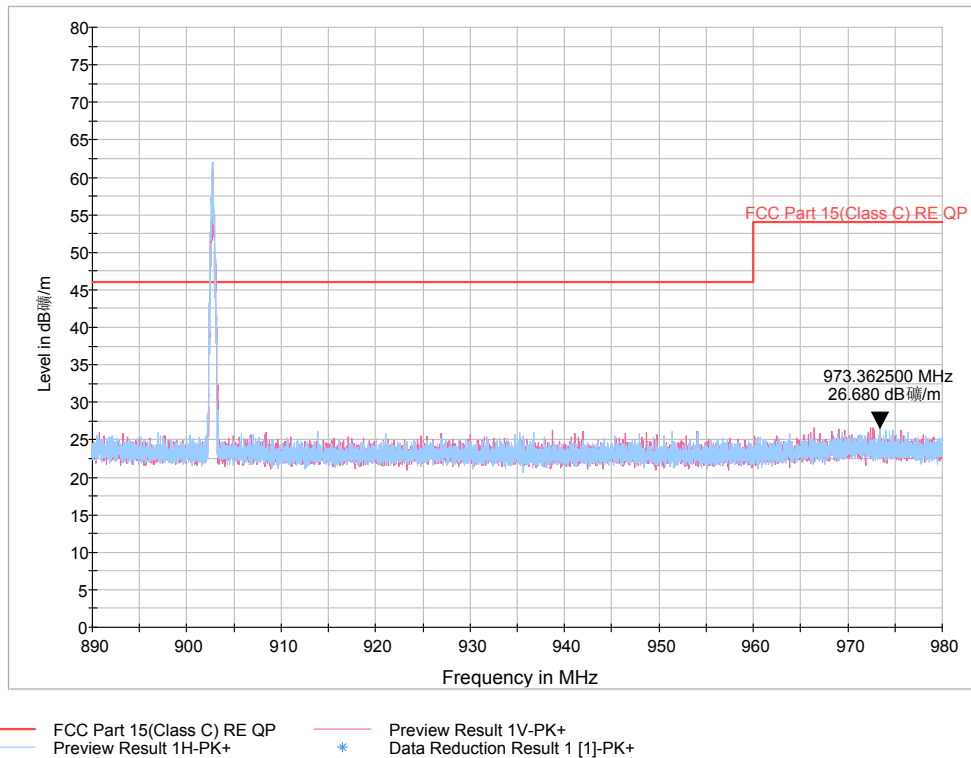

Note: The signal beyond the limit is carrier, a font (Level in dB μ V/m) in the test plot =(level in dBuV/m)

927.25 MHz

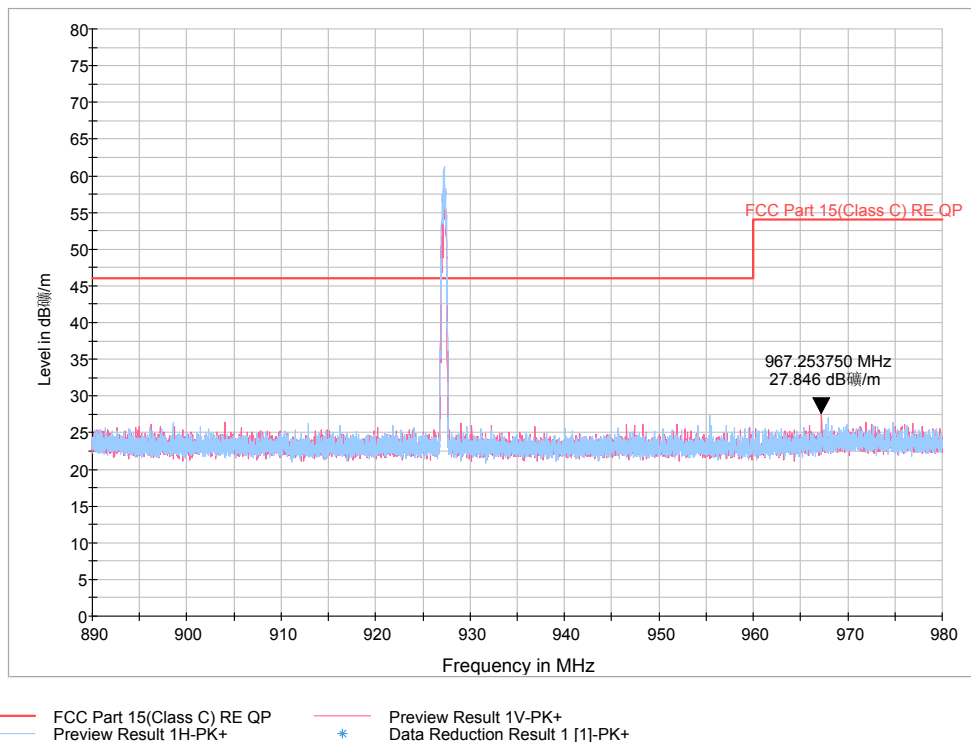

Note: The signal beyond the limit is carrier, a font (Level in dB μ V/m) in the test plot =(level in dBuV/m)

2.11. Number of hopping Frequency

Ambient condition

Temperature	Relative humidity	Pressure
23°C ~25°C	45%~50%	101.5kPa

Method of Measurement

The EUT was connected to the spectrum analyzer with a known loss. RBW is set to 510 kHz and VBW is set to 620 kHz on spectrum analyzer. Set EUT on Hopping on mode.

Test setup

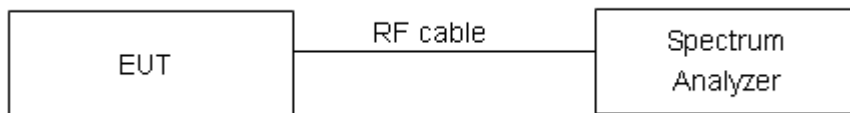

Limits

Rule Part 15.247(a) (1) (iii) specifies that "Frequency hopping systems in the 902–928 MHz band shall use at least 50 channels."

Limits	≥ 50 channels
--------	--------------------

TA Technology (Shanghai) Co., Ltd. Test Report

Report No.: RXA1507-0129RF01R2

Page 28of 58

Test Results:

915MHz

Number of hopping channels	conclusion
50	PASS

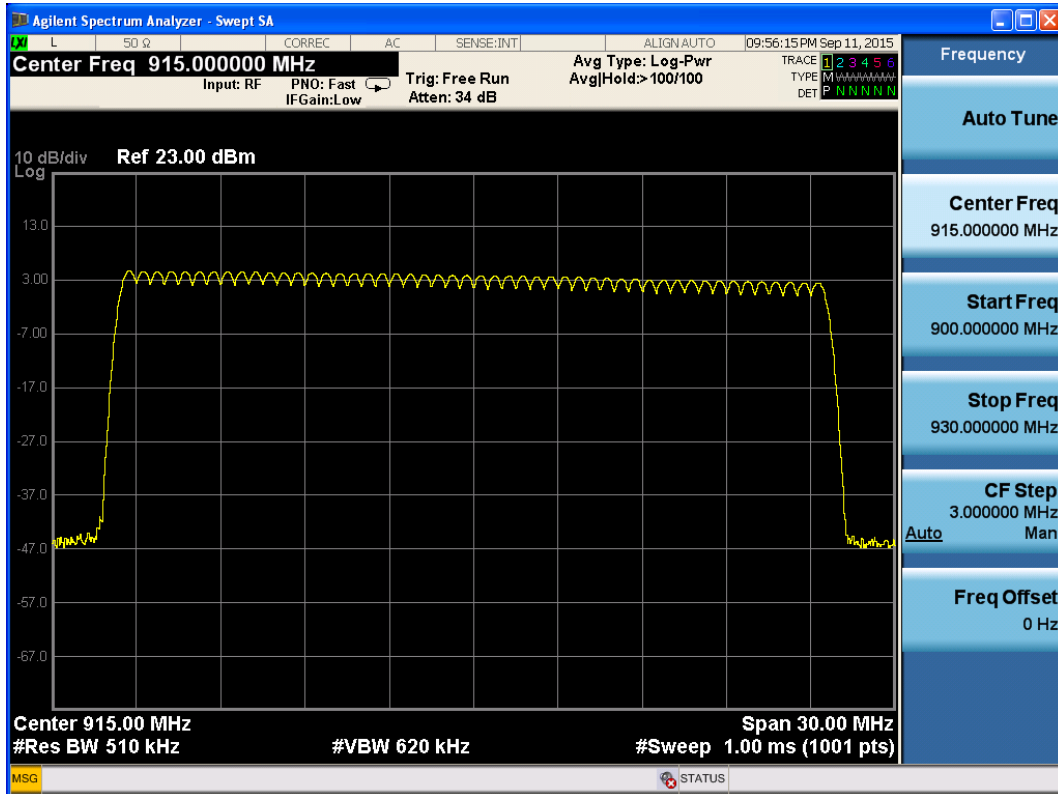

902 MHz –928 MHz

2.12. Spurious RF Conducted Emissions

Ambient condition

Temperature	Relative humidity	Pressure
23°C ~25°C	45%~50%	101.5kPa

Method of Measurement

The EUT was connected to the spectrum analyzer with a known loss. The spectrum analyzer scans from 30MHz to the 10th harmonic of the carrier. The peak detector is used. RBW and VBW are set to 100 kHz, Sweep is set to ATUO.

The test is in transmitting mode.

Test setup

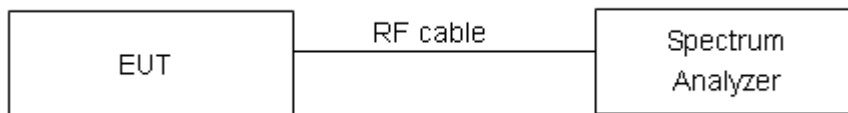

Limits

Rule Part 15.247(d) pacifies that “In any 100 kHz bandwidth outside the frequency band in which the spread spectrum intentional radiator is operating, the radio frequency power that is produced by the intentional radiator shall be at least 20 dB below that in the 100 kHz bandwidth within the band that contains the highest level of the desired power.”

Mode	Carrier frequency (MHz)	Reference value (dBm)	Limit(dBm)
RFID	902.75	9.522	≤-10.478
	915	9.443	≤-10.557
	927.25	9.202	≤-10.798

Measurement Uncertainty

The assessed measurement uncertainty to ensure 95% confidence level for the normal distribution is with the coverage factor $k = 1.96$.

Frequency	Uncertainty
100kHz-2GHz	0.684 dB
2GHz-26GHz	1.407 dB

TA Technology (Shanghai) Co., Ltd. Test Report

Test Results:
902.75MHz:

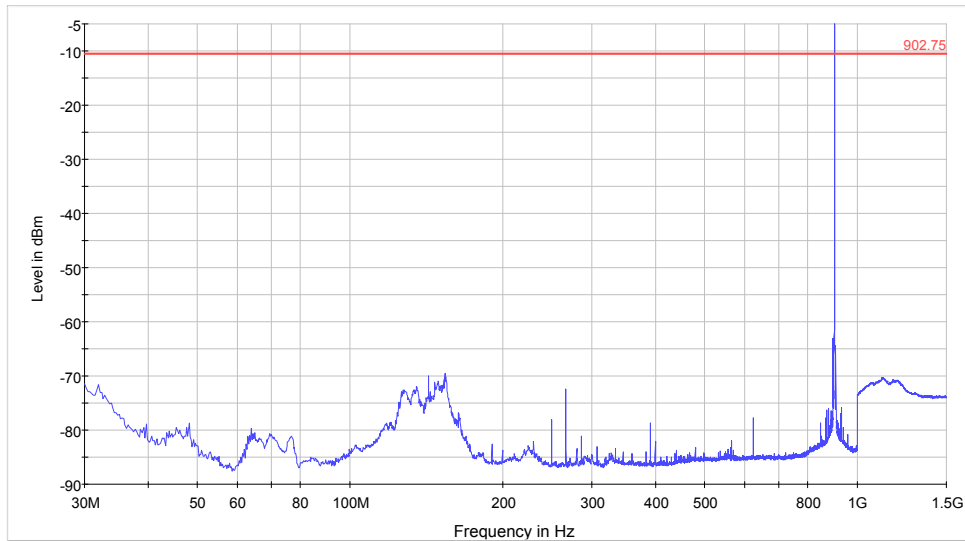

Average-MaxHold-AVG 902.75 902.75

Note: The signal beyond the limit is carrier. Carrier frequency (MHz): 902.3
Spurious RF conducted emissions from 30MHz to 1.5GHz

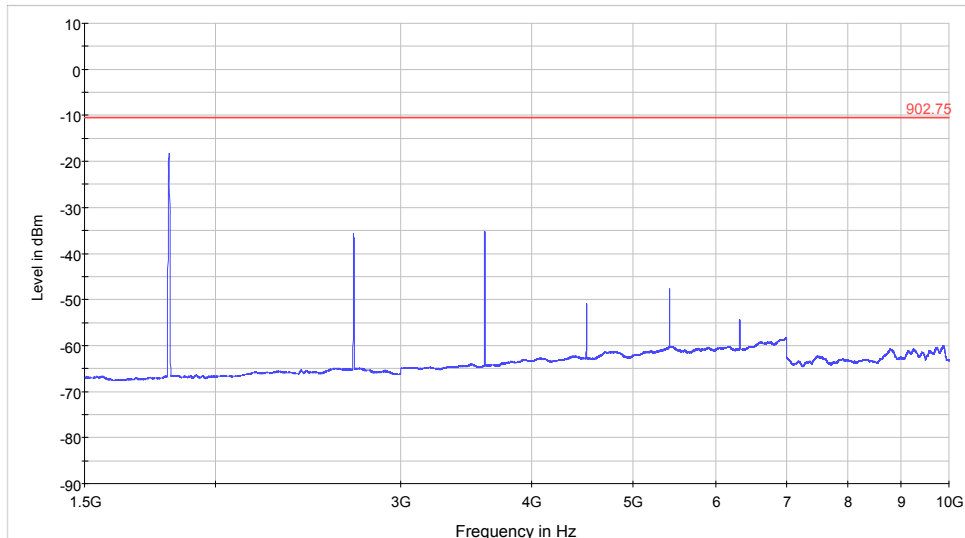

Average-MaxHold-AVG 902.75

Spurious RF conducted emissions from 1.5GHz to 10GHz

Harmonic	Frequency (MHz)	Level (dBm)	Limit (dBm)	Margin(dB)
2	1805.3	-18.36	-10.478	7.882
3	2708.1	-35.79	-10.478	25.312
4	3611.1	-35.15	-10.478	24.672
5	4513.7	-50.99	-10.478	40.512
6	5416.3	-47.77	-10.478	37.292
7	6318.8	-54.39	-10.478	43.912

TA Technology (Shanghai) Co., Ltd. Test Report

915 MHz:

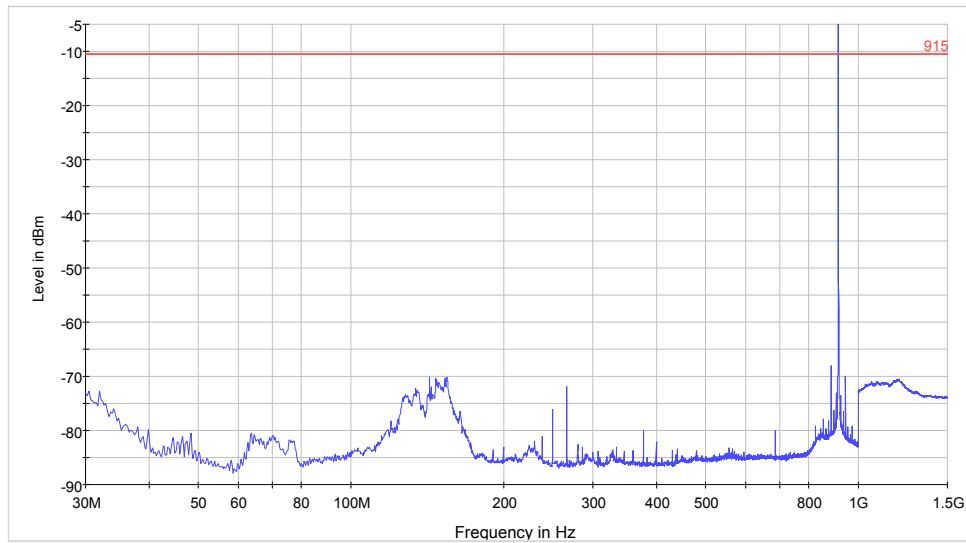

— Average-MaxHold-AVG — 915

Note: The signal beyond the limit is carrier. Carrier frequency (MHz): 914.7
Spurious RF conducted emissions from 30MHz to 1.5GHz

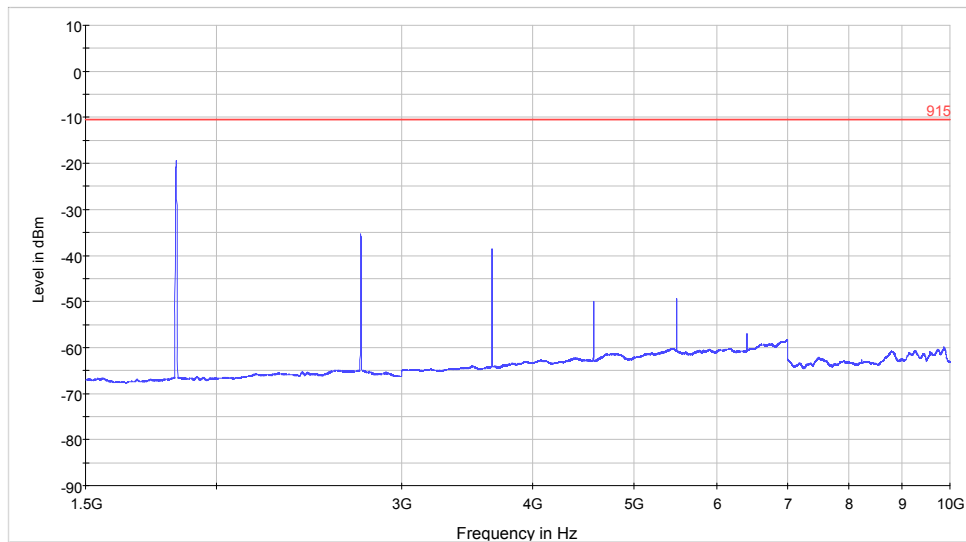

— Average-MaxHold-AVG — 915

Spurious RF conducted emissions from 1.5GHz to 10GHz

Harmonic	Frequency (MHz)	Level (dBm)	Limit (dBm)	Margin(dB)
2	1829.8	-19.43	-10.557	8.873
3	2745.0	-35.39	-10.557	24.833
4	3659.8	-38.63	-10.557	28.073
5	4574.8	-49.95	-10.557	39.393
6	5490.2	-49.46	-10.557	38.903
7	6405.0	-57.06	-10.557	46.503

TA Technology (Shanghai) Co., Ltd. Test Report

927.25 MHz:

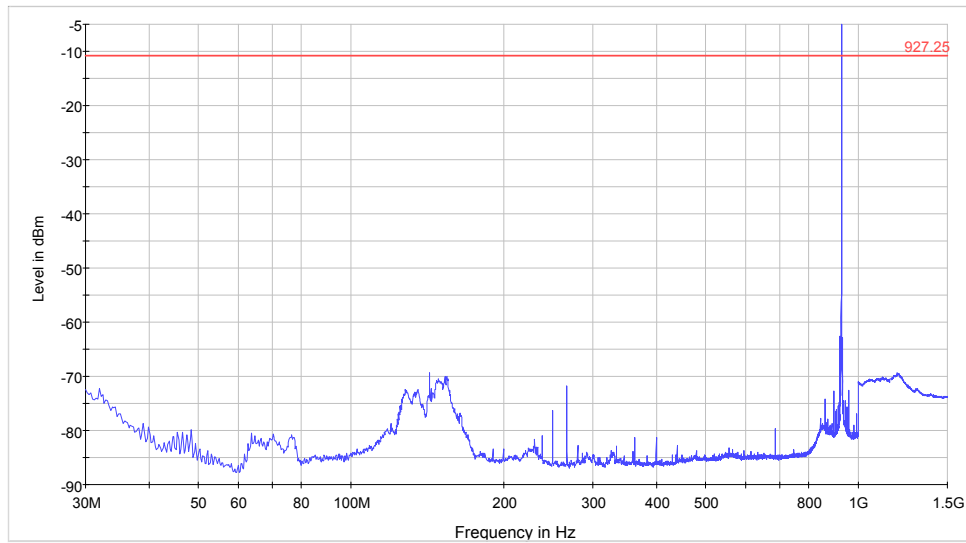

— Average-MaxHold-AVG — 927.25

Note: The signal beyond the limit is carrier. Carrier frequency (MHz): 927.7
Spurious RF conducted emissions from 30MHz to 1.5GHz

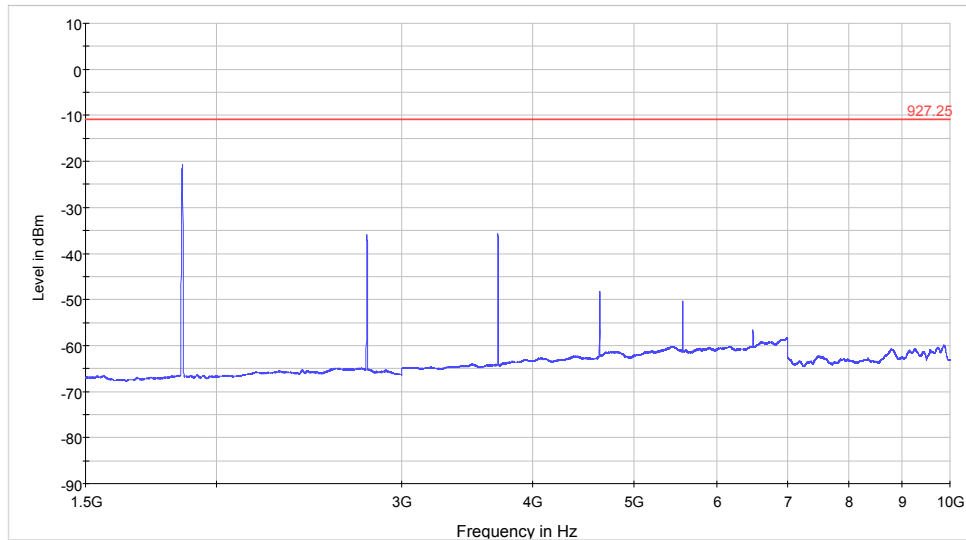

— Average-MaxHold-AVG — 927.25

Spurious RF conducted emissions from 1.5GHz to 10GHz

Harmonic	Frequency (MHz)	Level (dBm)	Limit (dBm)	Margin(dB)
2	1854.4	-20.82	-10.798	10.022
3	2781.8	-35.96	-10.798	25.162
4	3708.9	-35.79	-10.798	24.992
5	4636.3	-48.32	-10.798	37.522
6	5563.5	-50.33	-10.798	39.532
7	6490.1	-56.62	-10.798	45.822

2.13. Radiates Emission

Ambient condition

Temperature	Relative humidity	Pressure
23°C ~25°C	45%~50%	102.5kPa

Method of Measurement

The test set-up was made in accordance to the general provisions of ANSI C63.4-2014. The Equipment Under Test (EUT) was set up on a non-conductive table in the semi-anechoic chamber. The test was performed at the distance of 3 m between the EUT and the receiving antenna. The radiated emissions measurements were made in a typical installation configuration.

Sweep the whole frequency band through the range from 9kHz to the 10th harmonic of the carrier, and the emissions less than 20 dB below the permissible value are reported.

The height of receive antenna shall be moved from 1 to 4 meters, and the antenna shall be performed under horizontal and vertical polarization. The turntable shall be rotated from 0 to 360 degrees for detecting the maximum of radiated spurious signal level. The measurements shall be repeated with orthogonal polarization of the test antenna. The data of cable loss and antenna factor has been calibrated in full testing frequency range before the testing.

Set the spectrum analyzer in the following:

The emission limits shown in the above table are based on measurements employing a CISPR quasi-peak detector except for the frequency bands 9-90 kHz, 110-490 kHz and above 1000 MHz. Radiated emission limits in these three bands are based on measurements employing an average detector.

9kHz-15kHz

RBW=200Hz / VBW=600Hz / Sweep=AUTO

150kHz-30MHz

RBW=9kHz / VBW=27kHz / Sweep=AUTO

30MHz-1GHz

RBW=100kHz / VBW=300kHz / Sweep=AUTO

Above 1GHz

(a) PEAK: RBW=1MHz VBW=3MHz/ Sweep=AUTO

(b) AVERAGE: RBW=1MHz / VBW=10Hz / Sweep=AUTO

The radiated emission was measured in the following position: EUT stand-up position (Z axis), lie-down position (X, Y axis). The worst emission was found in stand-up position (Z axis) and the worst case was recorded. Then this mode was measured in the following mode: EUT with cradle and EUT without cradle. The worst emission was found in EUT with cradle mode and the worst case was recorded.

The test is in transmitting mode.

Test setup

9KHz~~~ 30MHz

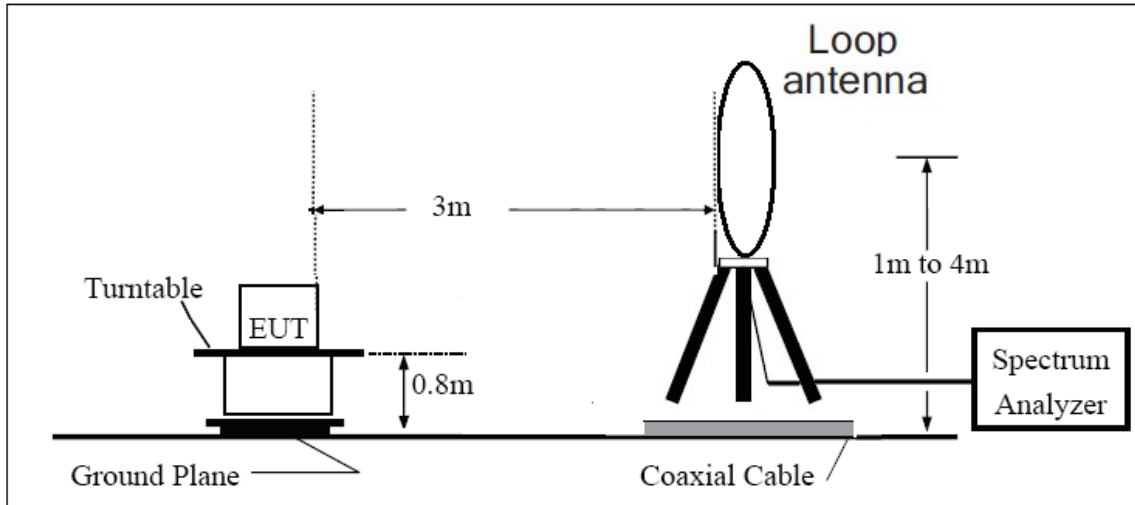

30MHz~~~ 1GHz

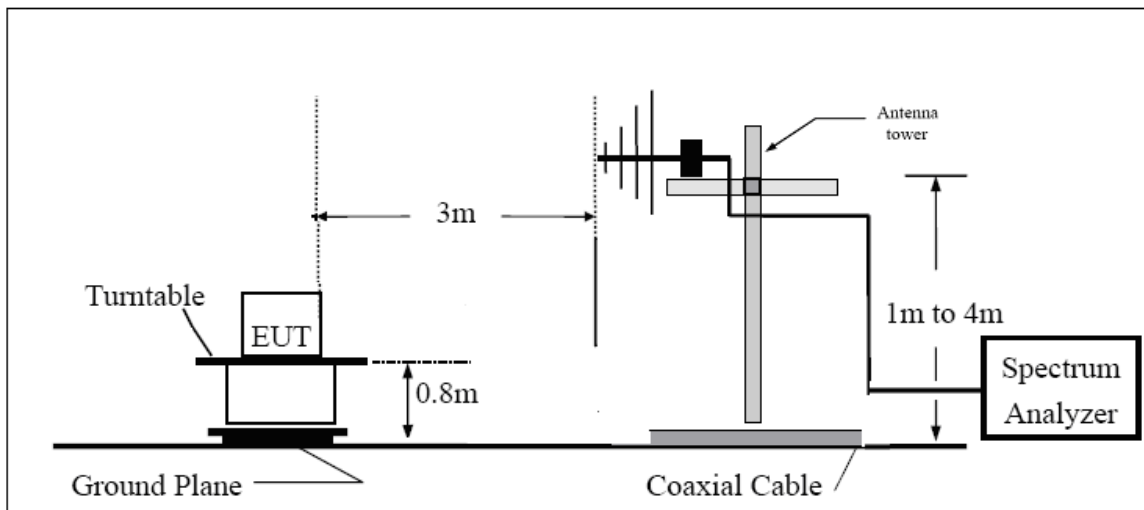

Above 1GHz

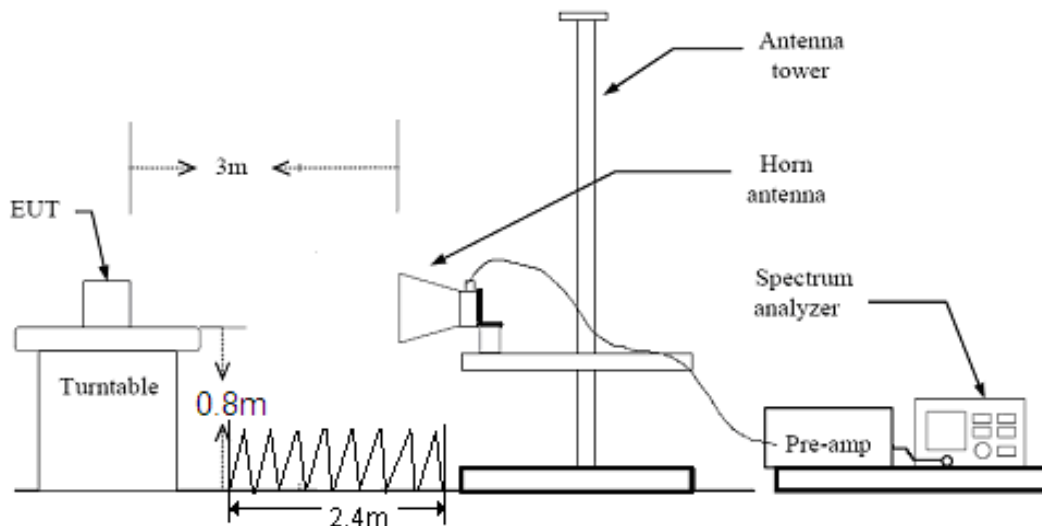

TA Technology (Shanghai) Co., Ltd.

Test Report

Report No.: RXA1507-0129RF01R2

Page 35 of 58

Limits

Rule Part 15.247(d) specifies that “In addition, radiated emissions which fall in the restricted bands, as defined in § 15.205(a), must also comply with the radiated emission limits specified in § 15.209(a) (see § 15.205(c)).”

Limit in restricted band

Frequency of emission (MHz)	Field strength(uV/m)	Field strength(dBuV/m)
0.009–0.490	2400/F(kHz)	107.6-20logF
0.490–1.705	24000/F(kHz)	107.6-20logF
1.705–30.0	30	50
30-88	100	40
88-216	150	43.5
216-960	200	46
Above960	500	54

§15.35(b)

There is also a limit on the radio frequency emissions, as measured using instrumentation with a peak detector function, corresponding to 20 dB above the maximum permitted average limit.

Measurement Uncertainty

The assessed measurement uncertainty to ensure 95% confidence level for the normal distribution is with the coverage factor $k = 1.96$.

Frequency	Uncertainty
9KHz-30MHz	3.55 dB
30MHz-200MHz	4.19 dB
200MHz-1GHz	3.63 dB
Above 1GHz	3.68 dB

TA Technology (Shanghai) Co., Ltd. Test Report

Test result

902.75MHz

RE 9K-30MHz

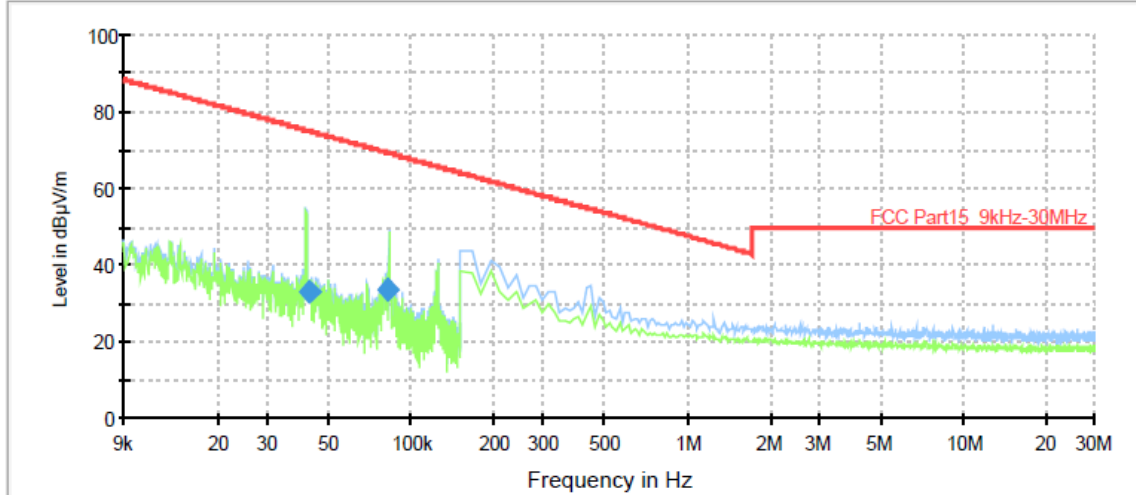

— FCC Part15 9kHz-30MHz [..]
— Preview Result 2-AVG [Preview Result 2.Result:2]
 ◆ Final Result 1-QPK [Final Result 1.Result:1]

Radiates Emission from 9 kHz to 30MHz

Frequency (MHz)	Quasi-Peak (dBuV/m)	Height (cm)	Azimuth (deg)	Reading value (dBuV/m)	Correct Factor (dB)	Margin (dB)	Limit (dBuV/m)
0.042430	33.2	100	0	52.2	19.0	41.8	75.0
0.081814	33.3	100	0	52.3	19.0	36.1	69.3

Remark: 1. Quasi-Peak = Reading value + Correction factor

2. Correction Factor = Antenna factor+ Insertion loss(cable loss+amplifier gain)

3. Margin = Limit – Quasi-Peak

TA Technology (Shanghai) Co., Ltd. Test Report

Report No.: RXA1507-0129RF01R2

Page 37 of 58

RE 0.03-1GHz QP Class B

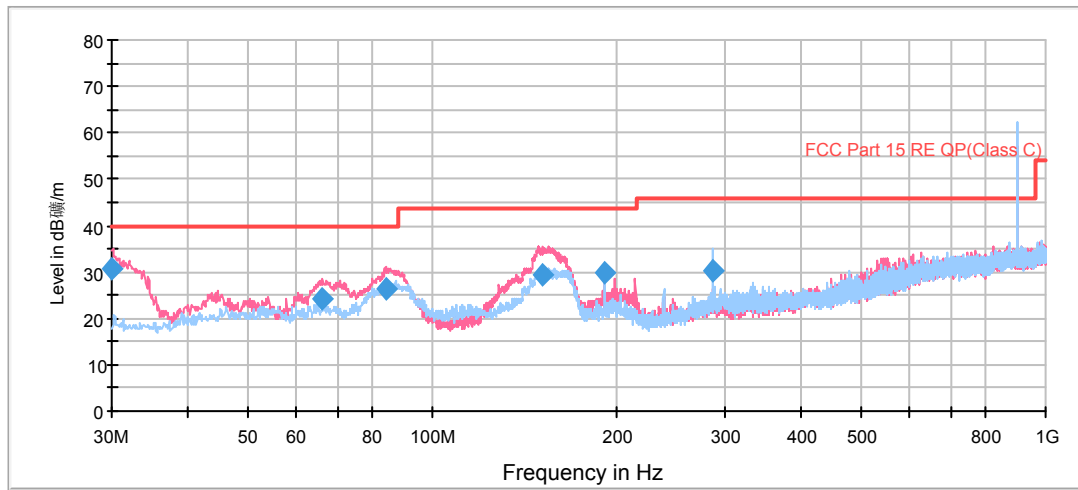

— FCC Part 15 RE QP(Class C) [...]
 — Preview Result 1V-PK+ [Preview Result 1V.Result:1]
— Preview Result 1H-PK+ [Preview Result 1H.Result:1]
 ◆ Final Result 1-QPK [Final Result 1.Result:1]

Note: a font (Level in dBuV/m)in the test plot =(level in dBuV/m)
Radiates Emission from 30MHz to 1GHz

Frequency (MHz)	Quasi-Peak (dBuV/m)	Height (cm)	Polarization	Azimuth (deg)	Reading value (dBuV/m)	Correct Factor (dB)	Margin (dB)	Limit (dBuV/m)
30.000000	30.7	100.0	V	356.0	41.9	11.2	9.3	40.0
66.013750	24.3	100.0	V	165.0	36.2	11.9	15.7	40.0
84.235000	26.2	125.0	V	196.0	35.5	9.3	13.8	40.0
151.495000	29.5	100.0	V	260.0	38.8	9.3	14.0	43.5
190.817500	29.9	100.0	V	10.0	41.3	11.4	13.6	43.5
286.201250	30.2	100.0	H	10.0	45.5	15.3	15.8	46.0

- Remark:**
1. Quasi-Peak = Reading value + Correction factor
 2. Correction Factor = Antenna factor+ Insertion loss(cable loss+amplifier gain)
 3. Margin = Limit – Quasi-Peak

TA Technology (Shanghai) Co., Ltd. Test Report

RE 1G-3GHz PK+AV

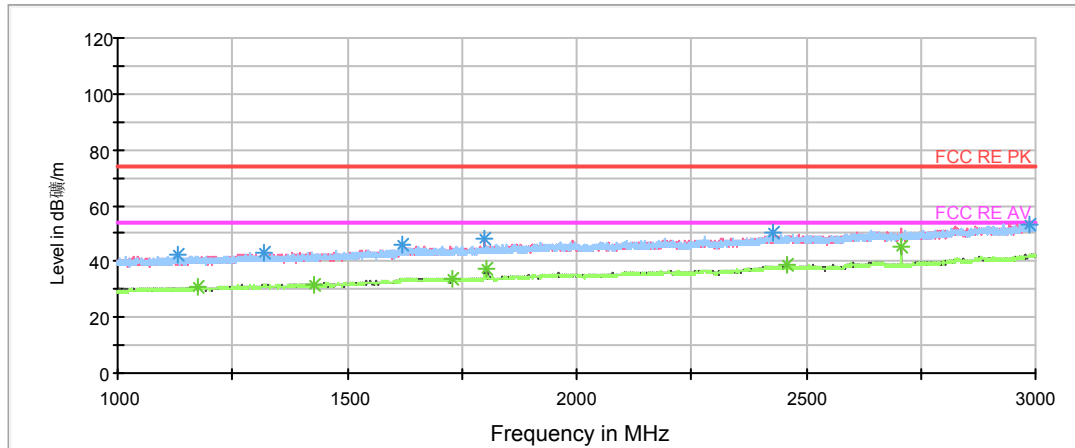

- FCC RE PK
- FCC RE AV
- Preview Result 1V-PK+
- Preview Result 2V-AVG
- Preview Result 1H-PK+
- Preview Result 2H-AVG
- * Data Reduction Result 1 [2]-PK+
- * Data Reduction Result 2 [2]-AVG

Radiates Emission from 1GHz to 3GHz

Note: The signal beyond the limit is carrier. a font ($\text{Level in dB}\frac{\mu\text{V}}{\text{m}}$) in the test plot =(level in dBuV/m)

Frequency (MHz)	Peak (dBuV/m)	Reading value (dBuV/m)	Height (cm)	Polarization	Azimuth (deg)	Correct Factor (dB)	Margin (dB)	Limit (dBuV/m)
1174.000000	39.8	47.9	100.0	V	314.0	-8.1	34.2	74
1427.750000	41.1	48.0	100.0	H	35.0	-6.9	32.9	74
1731.000000	43.9	48.8	100.0	V	338.0	-4.9	30.1	74
1805.500000	45.0	49.1	100.0	V	157.0	-4.1	29.0	74
2456.750000	48.8	49.3	100.0	V	120.0	-0.5	25.2	74
2708.250000	50.6	50.7	100.0	V	326.0	0.1	23.4	74

Frequency (MHz)	Average (dBuV/m)	Reading value (dBuV/m)	Height (cm)	Polarization	Azimuth (deg)	Correct Factor (dB)	Margin (dB)	Limit (dBuV/m)
1174.000000	30.9	39.0	100.0	V	314.0	-8.1	23.1	54
1427.750000	31.8	38.7	100.0	H	35.0	-6.9	22.2	54
1731.000000	34.1	39.0	100.0	V	338.0	-4.9	19.9	54
1805.500000	37.2	41.3	100.0	V	157.0	-4.1	16.8	54
2456.750000	38.5	39.0	100.0	V	120.0	-0.5	15.5	54
2708.250000	45.5	45.6	100.0	V	326.0	0.1	8.5	54

TA Technology (Shanghai) Co., Ltd. Test Report

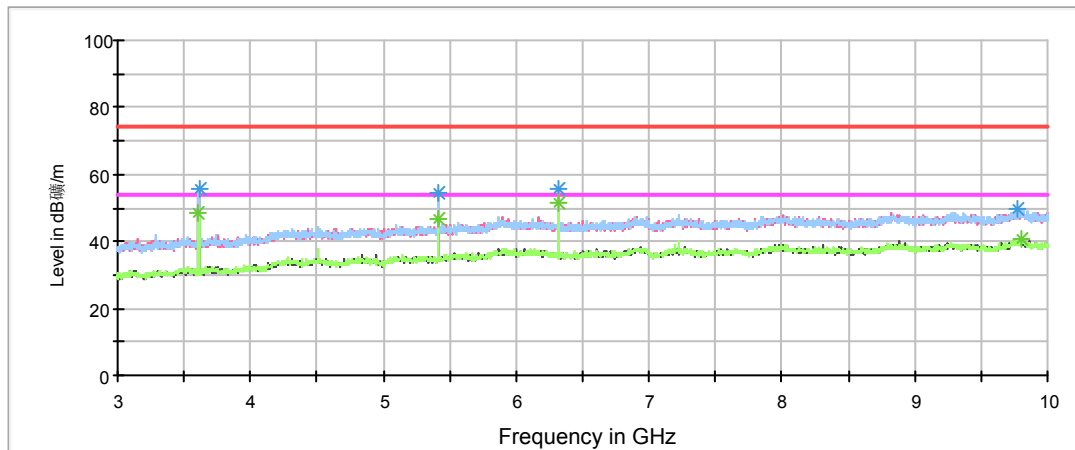

- FCC RE PK
- FCC RE AV
- Preview Result 1V-PK+
- Preview Result 2V-AVG
- Preview Result 1H-PK+
- Preview Result 2H-AVG
- * Data Reduction Result 1 [1]-PK+
- * Data Reduction Result 2 [1]-AVG

Radiates Emission from 3GHz to 10GHz

Note: a font (Level in dBuV/m) in the test plot =(level in dBuV/m)

Frequency (MHz)	Peak (dBuV/m)	Reading value (dBuV/m)	Height (cm)	Polarization	Azimuth (deg)	Correct Factor (dB)	Margin (dB)	Limit (dBuV/m)
3611.250000	56.0	56.8	200.0	H	251.0	-0.8	18.0	74
5416.875000	54.3	58.1	200.0	V	209.0	3.8	19.7	74
6318.750000	55.4	61.6	100.0	H	108.0	6.2	18.6	74
9766.875000	49.7	61.6	100.0	V	155.0	11.9	24.3	74
13065.000000	53.0	69.2	200.0	H	235.0	16.2	21.0	74
17977.500000	61.0	86.1	200.0	H	173.0	25.1	13.0	74

Frequency (MHz)	Average (dBuV/m)	Reading value (dBuV/m)	Height (cm)	Polarization	Azimuth (deg)	Correct Factor (dB)	Margin (dB)	Limit (dBuV/m)
3609.375000	48.6	49.4	200.0	H	251.0	-0.8	5.4	54
5416.875000	46.5	50.3	200.0	V	209.0	3.8	7.5	54
6318.750000	51.7	57.9	100.0	H	108.0	6.2	2.3	54
9802.500000	40.6	52.9	100.0	H	85.0	12.3	13.4	54
12701.250000	44.4	59.5	200.0	V	106.0	15.1	9.6	54
17992.500000	52.6	77.9	100.0	V	281.0	25.3	1.4	54

TA Technology (Shanghai) Co., Ltd. Test Report

915MHz

RE 9K-30MHz dbuv

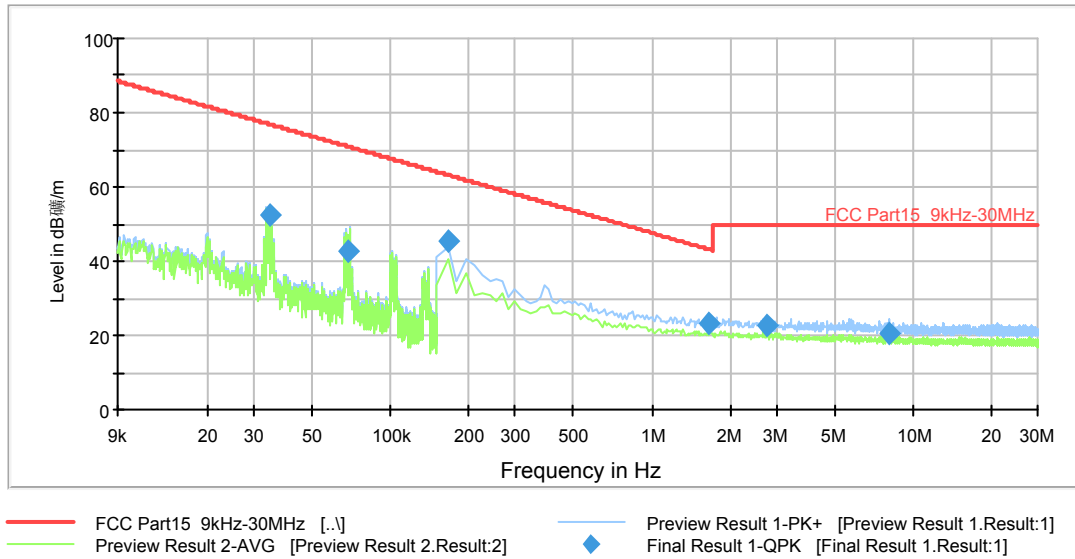

Radiates Emission from 9 kHz to 30MHz

Frequency (MHz)	Quasi-Peak (dBuV/m)	Height (cm)	Azimuth (deg)	Reading value (dBuV/m)	Correct Factor (dB)	Margin (dB)	Limit (dBuV/m)
0.034464	52.7	100	358.0	71.7	19.0	24.2	76.8
0.068489	42.5	100	358.0	61.5	19.0	28.4	70.9
0.166000	45.3	100	0.0	64.4	19.1	17.9	63.2
1.650275	23.2	100	0.0	42.3	19.1	20.0	43.2
2.780575	22.6	100	0.0	41.7	19.1	27.4	50.0
8.096025	20.3	100	0.0	39.5	19.2	29.7	50.0

- Remark: 1. Quasi-Peak = Reading value + Correction factor
 2. Correction Factor = Antenna factor+ Insertion loss(cable loss+amplifier gain)
 3. Margin = Limit – Quasi-Peak

TA Technology (Shanghai) Co., Ltd. Test Report

RE 0.03-1GHz QP Class B

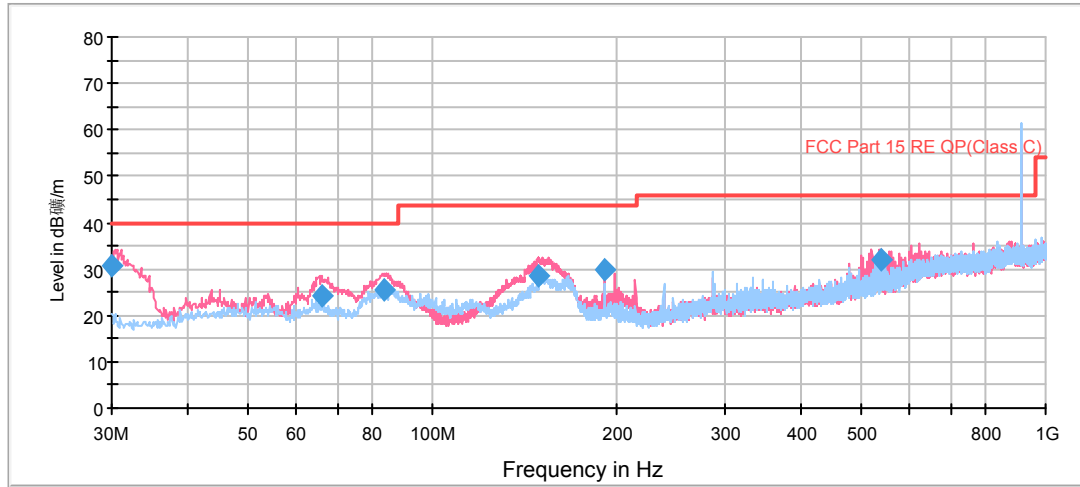

— FCC Part 15 RE QP(Class C) [..]
— Preview Result 1H-PK+ [Preview Result 1H.Result:1]
◆ Final Result 1-QPK [Final Result 1.Result:1]

Radiates Emission from 30MHz to 1GHz

Note: a font (Level in dBuV/m)in the test plot =(level in dBuV/m)

Frequency (MHz)	Quasi-Peak (dBuV/m)	Height (cm)	Polarization	Azimuth (deg)	Reading value (dBuV/m)	Correct Factor (dB)	Margin (dB)	Limit (dBuV/m)
30.000000	30.7	100.0	V	52.0	41.9	11.2	9.3	40.0
66.010000	24.3	100.0	V	77.0	36.2	11.9	15.7	40.0
83.707500	25.6	125.0	V	174.0	34.8	9.2	14.4	40.0
149.425000	28.6	100.0	V	257.0	37.8	9.2	14.9	43.5
190.817500	29.8	100.0	V	0.0	41.2	11.4	13.7	43.5
540.786250	32.1	100.0	V	157.0	52.4	20.3	13.9	46.0

Remark: 1. Quasi-Peak = Reading value + Correction factor

2. Correction Factor = Antenna factor+ Insertion loss(cable loss+amplifier gain)

3. Margin = Limit – Quasi-Peak

TA Technology (Shanghai) Co., Ltd. Test Report

RE 1G-3GHz PK+AV

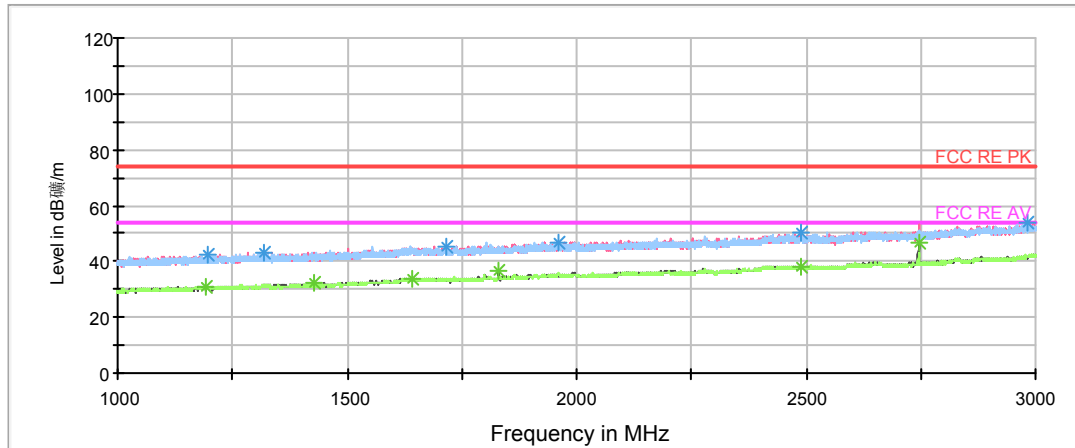

- FCC RE PK
- FCC RE AV
- Preview Result 1V-PK+
- Preview Result 2V-AVG
- Preview Result 1H-PK+
- Preview Result 2H-AVG
- * Data Reduction Result 1 [2]-PK+
- * Data Reduction Result 2 [2]-AVG

Radiates Emission from 1GHz to 3GHz

Note: The signal beyond the limit is carrier. a font (Level in dBμV/m) in the test plot =(level in dBuV/m)

Frequency (MHz)	Peak (dBuV/m)	Reading value (dBuV/m)	Height (cm)	Polarization	Azimuth (deg)	Correct Factor (dB)	Margin (dB)	Limit (dBuV/m)
1191.250000	40.5	48.7	100.0	V	246.0	-8.2	33.5	74
1428.750000	41.4	48.3	100.0	V	258.0	-6.9	32.6	74
1641.000000	43.2	47.9	100.0	V	217.0	-4.7	30.8	74
1829.750000	45.6	50.0	100.0	V	204.0	-4.4	28.4	74
2488.250000	48.1	48.3	100.0	V	357.0	0.2	25.9	74
2745.250000	52.4	53.2	100.0	V	21.0	0.8	21.6	74

Frequency (MHz)	Average (dBuV/m)	Reading value (dBuV/m)	Height (cm)	Polarization	Azimuth (deg)	Correct Factor (dB)	Margin (dB)	Limit (dBuV/m)
1191.250000	30.8	39.0	100.0	V	246.0	-8.2	23.2	54
1428.750000	32.1	39.0	100.0	V	258.0	-6.9	21.9	54
1641.000000	34.1	38.8	100.0	V	217.0	-4.7	19.9	54
1829.750000	36.6	41.0	100.0	V	204.0	-4.4	17.4	54
2488.250000	38.4	38.6	100.0	V	357.0	0.2	15.6	54
2745.250000	46.5	47.3	100.0	V	21.0	0.8	7.5	54

TA Technology (Shanghai) Co., Ltd. Test Report

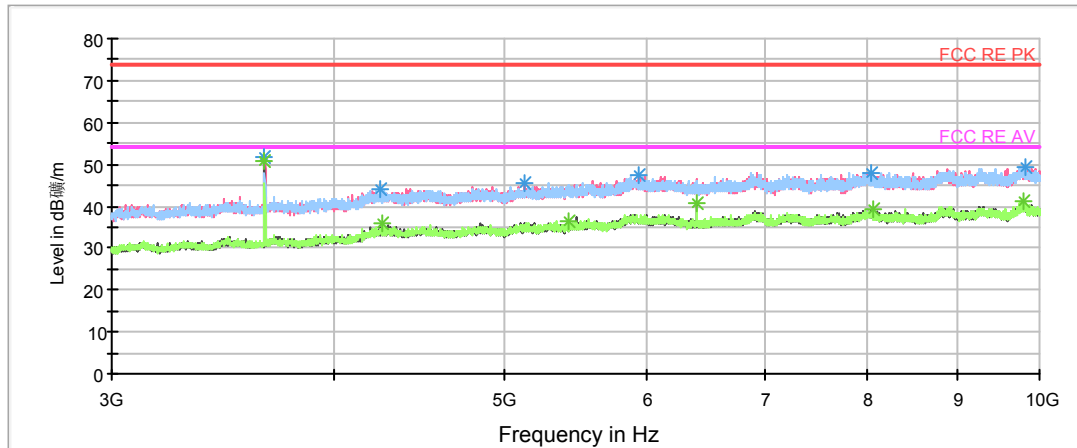

- FCC RE PK
 - Preview Result 1V-PK+
 - Preview Result 1H-PK+
 - * Data Reduction Result 1 [1]-PK+
- FCC RE AV
 - Preview Result 2V-AVG
 - Preview Result 2H-AVG
 - * Data Reduction Result 2 [1]-AVG

Radiates Emission from 3GHz to 10GHz

Note: a font (Level in dB μ V/m)in the test plot =(level in dBuv/m)

Frequency (MHz)	Peak (dBuV/m)	Reading value (dBuV/m)	Height (cm)	Polarization	Azimuth (deg)	Correct Factor (dB)	Margin (dB)	Limit (dBuV/m)
3659.750000	51.7	52.2	200.0	V	154.0	-0.5	22.3	74
4245.125000	44.1	46.0	200.0	H	205.0	1.9	29.9	74
5121.875000	45.5	49.1	200.0	V	2.0	3.6	28.5	74
5947.875000	47.6	53.7	100.0	V	80.0	6.1	26.4	74
8037.375000	48.1	56.8	100.0	H	0.0	8.7	25.9	74
9811.875000	49.6	61.8	200.0	H	268.0	12.2	24.4	74

Frequency (MHz)	Average (dBuV/m)	Reading value (dBuV/m)	Height (cm)	Polarization	Azimuth (deg)	Correct Factor (dB)	Margin (dB)	Limit (dBuV/m)
3659.750000	50.5	51.0	200.0	V	154.0	-0.5	3.5	54
4264.375000	35.9	37.9	100.0	H	228.0	2.0	18.1	54
5429.000000	36.3	40.1	100.0	V	306.0	3.8	17.7	54
6404.625000	40.6	46.9	200.0	V	92.0	6.3	13.4	54
8049.625000	39.1	47.8	200.0	H	339.0	8.7	14.9	54
9805.750000	41.4	53.6	100.0	V	0.0	12.2	12.6	54

TA Technology (Shanghai) Co., Ltd. Test Report

Report No.: RXA1507-0129RF01R2

Page 44 of 58

927.25MHz

RE 9K-30MHz dbuv

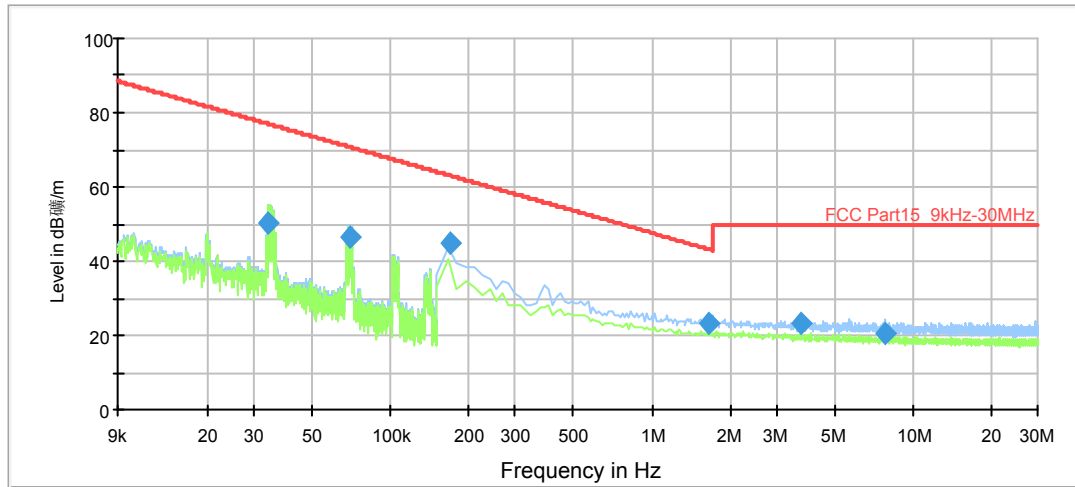

— FCC Part15 9kHz-30MHz [..]
— Preview Result 2-AVG [Preview Result 2.Result:2] — Preview Result 1-PK+ [Preview Result 1.Result:1]
◆ Final Result 1-QPK [Final Result 1.Result:1]

Radiates Emission from 9 kHz to 30MHz

Frequency (MHz)	Quasi-Peak (dBuV/m)	Height (cm)	Azimuth (deg)	Reading value (dBuV/m)	Correct Factor (dB)	Margin (dB)	Limit (dBuV/m)
0.033732	50.3	100	0.0	69.3	19.0	26.7	77.0
0.069758	46.4	100	0.0	65.4	19.0	24.3	70.7
0.170000	45.0	100	0.0	64.1	19.1	18.0	63.0
1.661500	23.3	100	0.0	42.4	19.1	19.9	43.2
3.708075	23.2	100	0.0	42.3	19.1	26.8	50.0
7.815675	20.6	100	0.0	39.8	19.2	29.4	50.0

- Remark:**
1. Quasi-Peak = Reading value + Correction factor
 2. Correction Factor = Antenna factor+ Insertion loss(cable loss+amplifier gain)
 3. Margin = Limit – Quasi-Peak

TA Technology (Shanghai) Co., Ltd. Test Report

Report No.: RXA1507-0129RF01R2

Page 45 of 58

RE 0.03-1GHz QP Class B

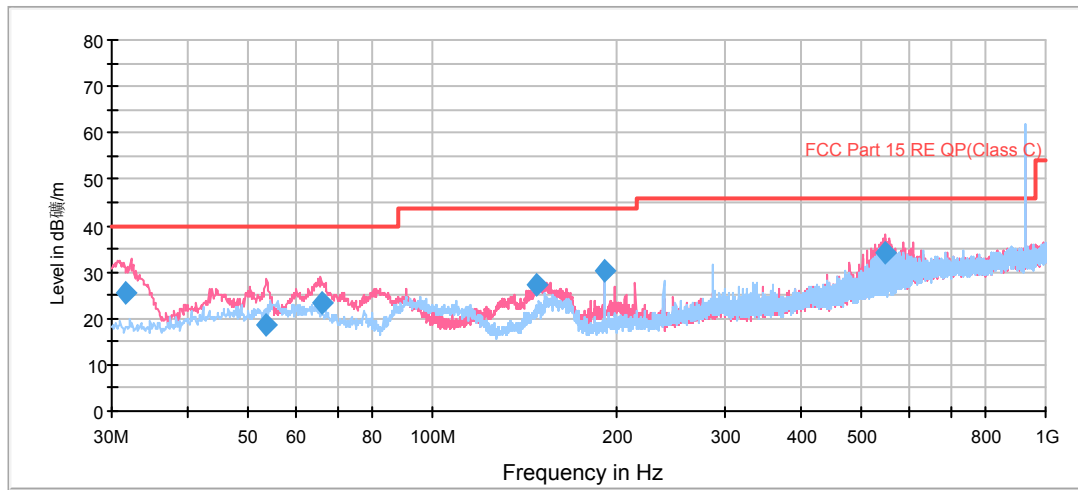

— FCC Part 15 RE QP(Class C) [..]
— Preview Result 1H-PK+ [Preview Result 1H.Result:1]
— Preview Result 1V-PK+ [Preview Result 1V.Result:1]
◆ Final Result 1-QPK [Final Result 1.Result:1]

Radiates Emission from 30MHz to 1GHz

Note: a font (Level in dBu/m) in the test plot =(level in dBuV/m)

Frequency (MHz)	Quasi-Peak (dBuV/m)	Height (cm)	Polarization	Azimuth (deg)	Reading value (dBuV/m)	Correct Factor (dB)	Margin (dB)	Limit (dBuV/m)
31.703750	25.4	100.0	V	22.0	36.7	11.3	14.6	40.0
53.723750	18.6	100.0	V	254.0	32.9	14.3	21.4	40.0
66.008750	23.5	114.0	V	140.0	35.4	11.9	16.5	40.0
148.377500	27.4	100.0	V	326.0	36.5	9.1	16.1	43.5
190.817500	30.4	100.0	V	352.0	41.8	11.4	13.1	43.5
547.212500	34.0	100.0	V	172.0	54.2	20.2	12.0	46.0

Remark: 1. Quasi-Peak = Reading value + Correction factor

2. Correction Factor = Antenna factor+ Insertion loss(cable loss+amplifier gain)

3. Margin = Limit – Quasi-Peak

TA Technology (Shanghai) Co., Ltd. Test Report

RE 1G-3GHz PK+AV

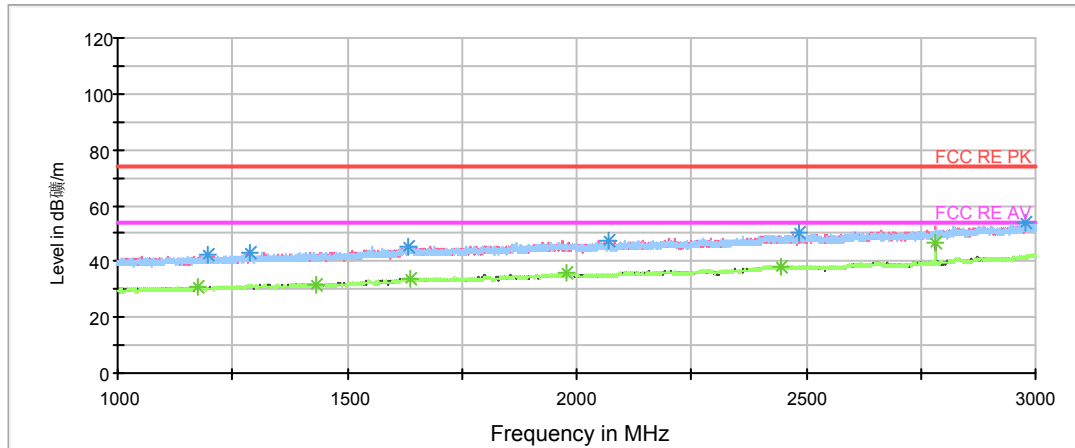

- FCC RE PK
- FCC RE AV
- Preview Result 1V-PK+
- Preview Result 1H-PK+
- * Data Reduction Result 1 [2]-PK+
- Preview Result 2V-AVG
- Preview Result 2H-AVG
- * Data Reduction Result 2 [2]-AVG

Radiates Emission from 1GHz to 3GHz

Note: The signal beyond the limit is carrier. a font ($\text{Level in dB}\frac{\mu\text{V}}{\text{m}}$) in the test plot =(level in dBuV/m)

Frequency (MHz)	Peak (dBuV/m)	Reading value (dBuV/m)	Height (cm)	Polarization	Azimuth (deg)	Correct Factor (dB)	Margin (dB)	Limit (dBuV/m)
1175.750000	40.4	48.4	100.0	H	0.0	-8.0	33.6	74
1430.250000	41.6	48.5	100.0	V	66.0	-6.9	32.4	74
1637.000000	43.6	48.3	100.0	V	136.0	-4.7	30.4	74
1980.250000	44.6	48.3	100.0	V	240.0	-3.7	29.4	74
2443.250000	47.6	48.0	100.0	H	162.0	-0.4	26.4	74
2781.750000	52.3	53.2	100.0	V	346.0	0.9	21.7	74

Frequency (MHz)	Average (dBuV/m)	Reading value (dBuV/m)	Height (cm)	Polarization	Azimuth (deg)	Correct Factor (dB)	Margin (dB)	Limit (dBuV/m)
1175.750000	30.8	38.8	100.0	H	0.0	-8.0	23.2	54
1430.250000	31.9	38.8	100.0	V	66.0	-6.9	22.1	54
1637.000000	34.1	38.8	100.0	V	136.0	-4.7	19.9	54
1980.250000	35.8	39.5	100.0	V	240.0	-3.7	18.2	54
2443.250000	38.4	38.8	100.0	H	162.0	-0.4	15.6	54
2781.750000	46.4	47.3	100.0	V	346.0	0.9	7.6	54

TA Technology (Shanghai) Co., Ltd. Test Report

Report No.: RXA1507-0129RF01R2

Page 47 of 58

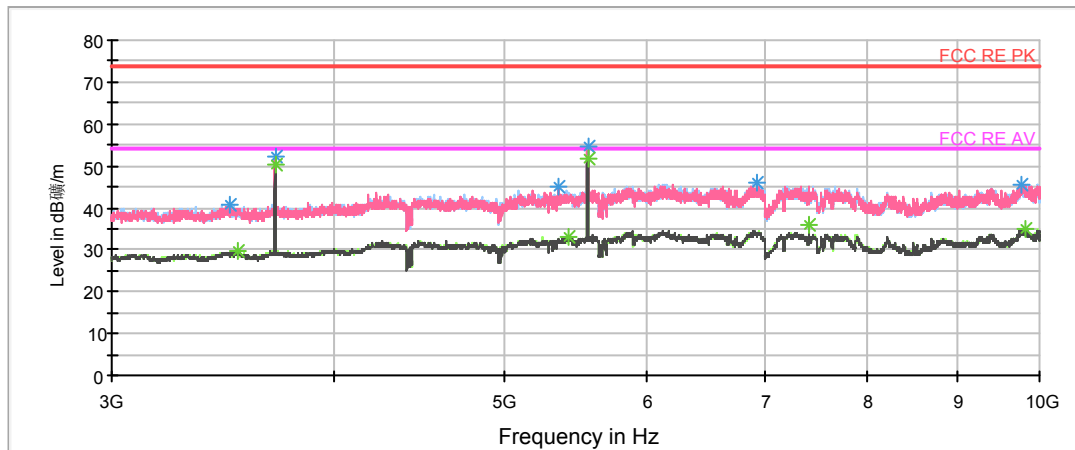

- FCC RE PK
- FCC RE AV
- * Preview Result 1H-PK+
- * Preview Result 2H-AVG
- Preview Result 1V-PK+
- Preview Result 2V-AVG
- * Data Reduction Result 1 [1]-PK+
- * Data Reduction Result 2 [1]-AVG

Radiates Emission from 3GHz to 10GHz

Note: a font (Level in dBuV/m) in the test plot =(level in dBuV/m)

Frequency (MHz)	Peak (dBuV/m)	Reading value (dBuV/m)	Height (cm)	Polarization	Azimuth (deg)	Correct Factor (dB)	Margin (dB)	Limit (dBuV/m)
3501.375000	40.8	41.3	100.0	V	0.0	-0.5	33.2	74
3708.750000	52.3	52.6	100.0	V	4.0	-0.3	21.7	74
5352.000000	44.9	48.6	100.0	V	4.0	3.7	29.1	74
5563.750000	54.8	59.3	100.0	V	36.0	4.5	19.2	74
6928.750000	45.9	52.7	100.0	H	334.0	6.8	28.1	74
9758.500000	45.7	57.5	100.0	V	51.0	11.8	28.3	74

Frequency (MHz)	Average (dBuV/m)	Reading value (dBuV/m)	Height (cm)	Polarization	Azimuth (deg)	Correct Factor (dB)	Margin (dB)	Limit (dBuV/m)
3535.500000	29.8	30.4	100.0	H	0.0	-0.6	24.2	54
3708.750000	50.4	50.7	100.0	V	4.0	-0.3	3.6	54
5432.500000	33.1	36.9	100.0	H	0.0	3.8	20.9	54
5563.750000	51.9	56.4	100.0	V	36.0	4.5	2.1	54
7417.875000	36.1	43.9	100.0	V	0.0	7.8	17.9	54
9811.000000	35.0	47.2	100.0	V	333.0	12.2	19.0	54

2.14. AC Power Line Conducted Emission

Ambient condition

Temperature	Relative humidity	Pressure
23°C ~25°C	45%~50%	101.5kPa

Method of Measurement

The EUT IS placed on a non-metallic table of 80cm height above the horizontal metal reference ground plane. During the test, the EUT was operating in its typical mode. The test method is according to ANSIC63.4-2014. Connect the AC power line of the EUT to the LISN Use EMI receiver to detect the average and Quasi-peak value. RBW is set to 9kHz,VBW is set to 30kHz The measurement result should include both L line and N line.

The test is in transmitting mode.

Test setup

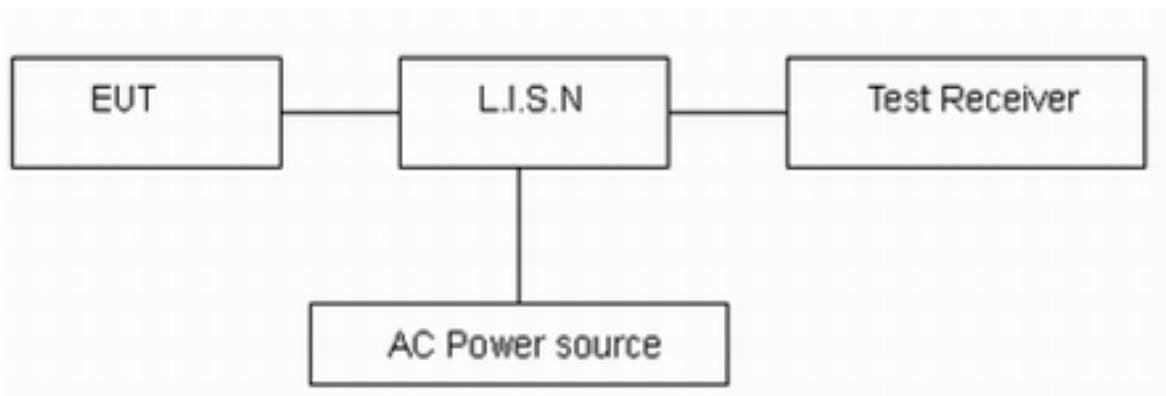

Note: AC Power source is used to change the voltage from 220V/50Hz to 110V/60Hz.

Limits

Frequency (MHz)	Conducted Limits(dBμV)	
	Quasi-peak	Average
0.15 - 0.5	66 to 56 *	56 to 46 *
0.5 - 5	56	46
5 - 30	60	50

*: Decreases with the logarithm of the frequency.

Measurement Uncertainty

The assessed measurement uncertainty to ensure 95% confidence level for the normal distribution is with the coverage factor $k = 1.96$, $U = 2.69$ dB.

TA Technology (Shanghai) Co., Ltd. Test Report

Report No.: RXA1507-0129RF01R2

Page 49of 58

Test Results:

902.75MHz

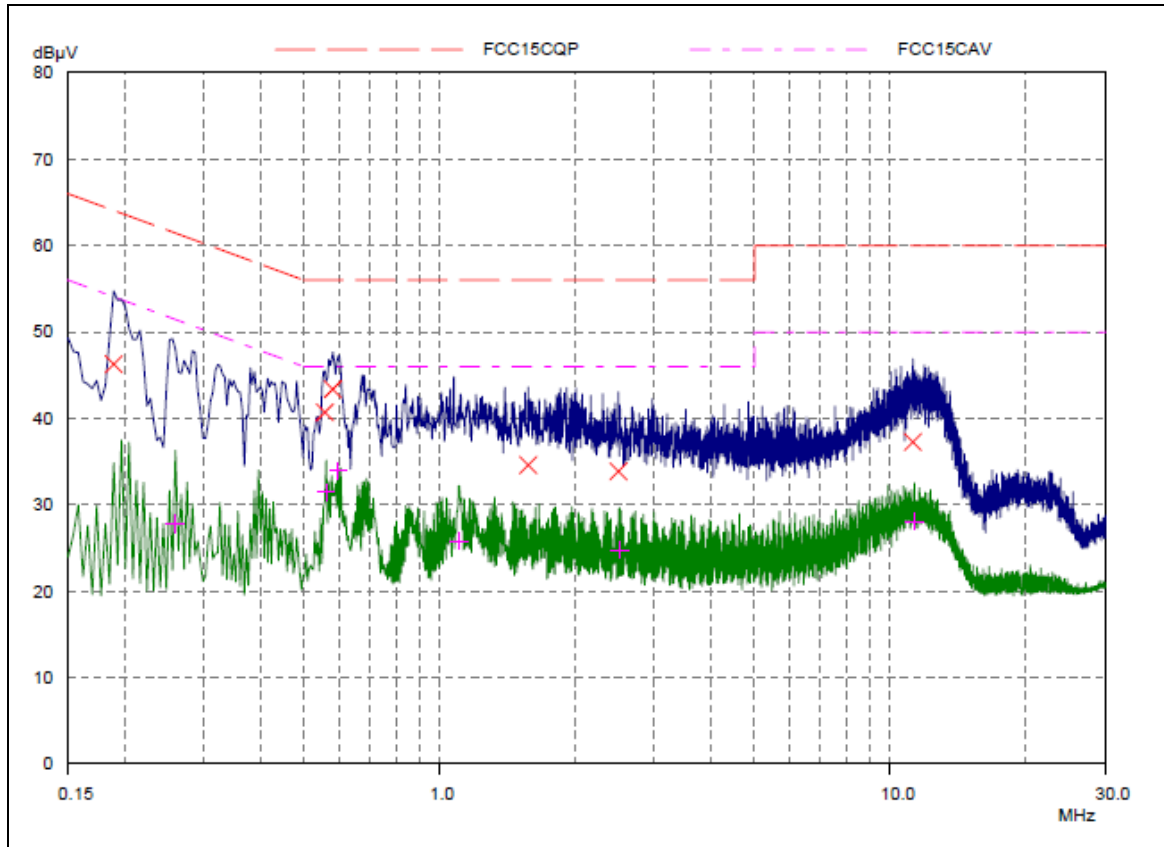

Final Measurement Results

Frequency MHz	QP Level dBµV	QP Limit dBµV	QP Delta dB	Phase -	PE -
0.18906	46.26	64.08	17.82	L1	gnd
0.55625	40.70	56.00	15.30	L1	gnd
0.57968	43.36	56.00	12.64	L1	gnd
1.57187	34.58	56.00	21.42	L1	gnd
2.49375	33.88	56.00	22.12	L1	gnd
11.23203	37.27	60.00	22.73	L1	gnd

Frequency MHz	AV Level dBµV	AV Limit dBµV	AV Delta dB	Phase -	PE -
0.25937	27.81	51.45	23.64	L1	gnd
0.56015	31.46	46.00	14.54	L1	gnd
0.59531	33.94	46.00	12.06	L1	gnd
1.10312	25.79	46.00	20.21	L1	gnd
2.51328	24.76	46.00	21.24	L1	gnd
11.31015	28.05	50.00	21.95	L1	gnd

L Line

TA Technology (Shanghai) Co., Ltd. Test Report

Report No.: RXA1507-0129RF01R2

Page 50 of 58

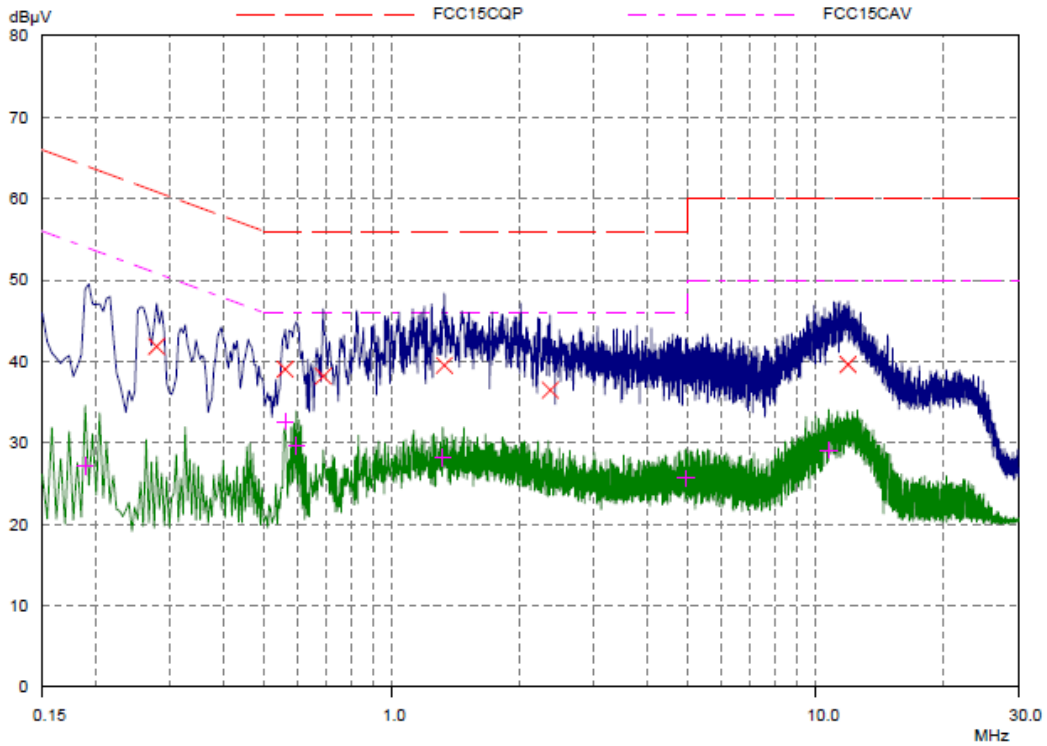

Final Measurement Results

Frequency MHz	QP Level dBµV	QP Limit dBµV	QP Delta dB	Phase -	PE -
0.2789	41.84	60.85	19.01	N	gnd
0.56015	39.04	56.00	16.96	N	gnd
0.68906	38.18	56.00	17.82	N	gnd
1.32968	39.52	56.00	16.48	N	gnd
2.36093	36.48	56.00	19.52	N	gnd
11.90781	39.64	60.00	20.36	N	gnd

Frequency MHz	AV Level dBµV	AV Limit dBµV	AV Delta dB	Phase -	PE -
0.18906	27.19	54.08	26.89	N	gnd
0.56015	32.60	46.00	13.40	N	gnd
0.59531	29.63	46.00	16.37	N	gnd
1.31796	28.18	46.00	17.82	N	gnd
4.94296	25.65	46.00	20.35	N	gnd
10.7125	29.10	50.00	20.90	N	gnd

N Line

TA Technology (Shanghai) Co., Ltd. Test Report

Report No.: RXA1507-0129RF01R2

Page 51 of 58

915MHz

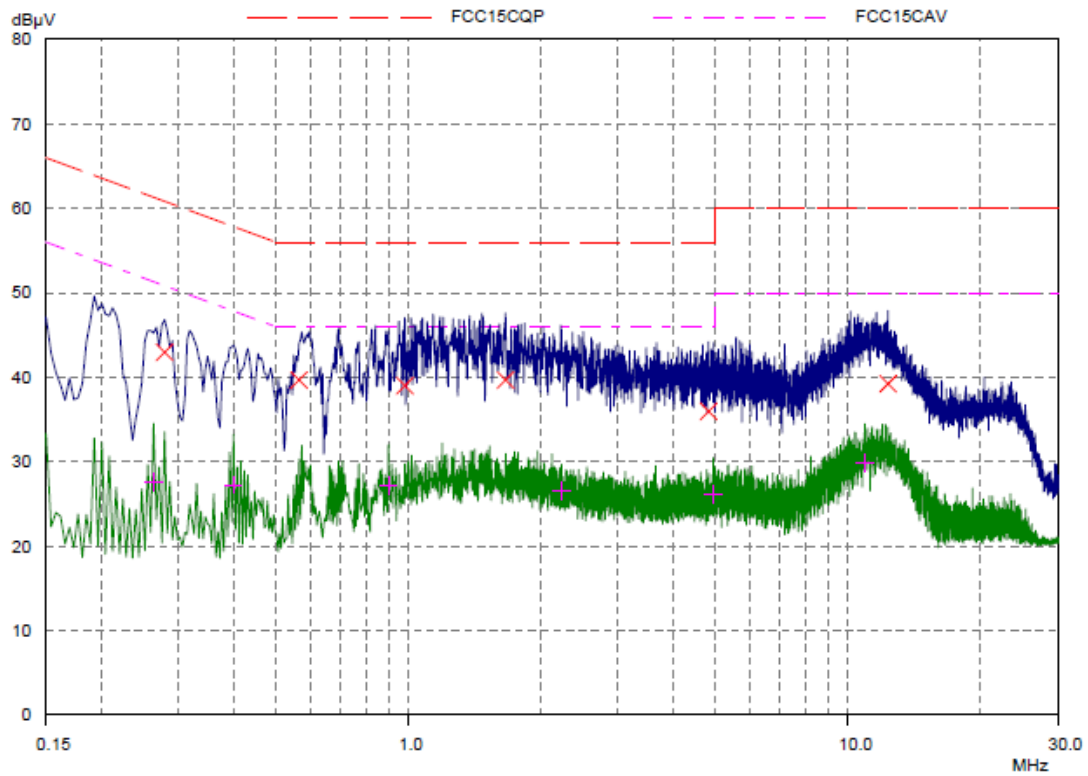

Final Measurement Results

Frequency MHz	QP Level dBµV	QP Limit dBµV	QP Delta dB	Phase -	PE -
0.2789	42.98	60.85	17.87	L1	gnd
0.56406	39.68	56.00	16.32	L1	gnd
0.98203	39.00	56.00	17.00	L1	gnd
1.66171	39.68	56.00	16.32	L1	gnd
4.81406	35.96	56.00	20.04	L1	gnd
12.32578	39.23	60.00	20.77	L1	gnd

Frequency MHz	AV Level dBµV	AV Limit dBµV	AV Delta dB	Phase -	PE -
0.26328	27.59	51.33	23.74	L1	gnd
0.4	27.24	47.85	20.61	L1	gnd
0.9	27.19	46.00	18.81	L1	gnd
2.22812	26.58	46.00	19.42	L1	gnd
4.93125	26.13	46.00	19.87	L1	gnd
10.92343	29.91	50.00	20.09	L1	gnd

L Line

TA Technology (Shanghai) Co., Ltd. Test Report

Report No.: RXA1507-0129RF01R2

Page 52 of 58

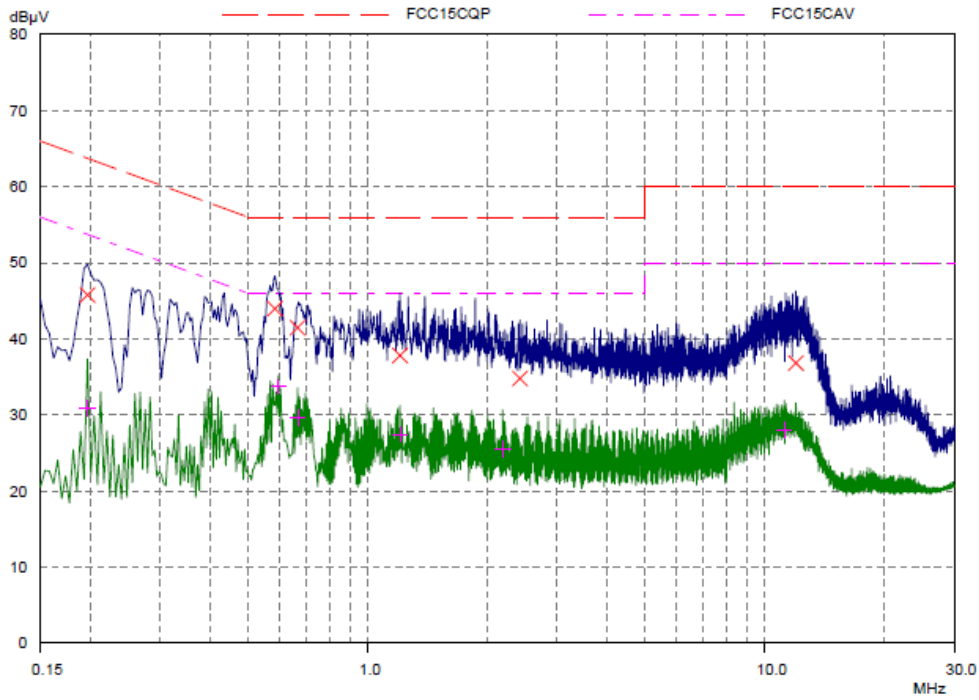

Final Measurement Results

Frequency MHz	QP Level dBµV	QP Limit dBµV	QP Delta dB	Phase -	PE -
0.19687	45.76	63.74	17.98	N	gnd
0.58359	43.98	56.00	12.02	N	gnd
0.66562	41.46	56.00	14.54	N	gnd
1.20468	37.82	56.00	18.18	N	gnd
2.41562	34.80	56.00	21.20	N	gnd
11.9664	36.82	60.00	23.18	N	gnd

Frequency MHz	AV Level dBµV	AV Limit dBµV	AV Delta dB	Phase -	PE -
0.19687	30.86	53.74	22.88	N	gnd
0.59531	33.72	46.00	12.28	N	gnd
0.66562	29.63	46.00	16.37	N	gnd
1.20468	27.47	46.00	18.53	N	gnd
2.18515	25.51	46.00	20.49	N	gnd
11.19687	28.00	50.00	22.00	N	gnd

N Line

TA Technology (Shanghai) Co., Ltd. Test Report

927.25MHz

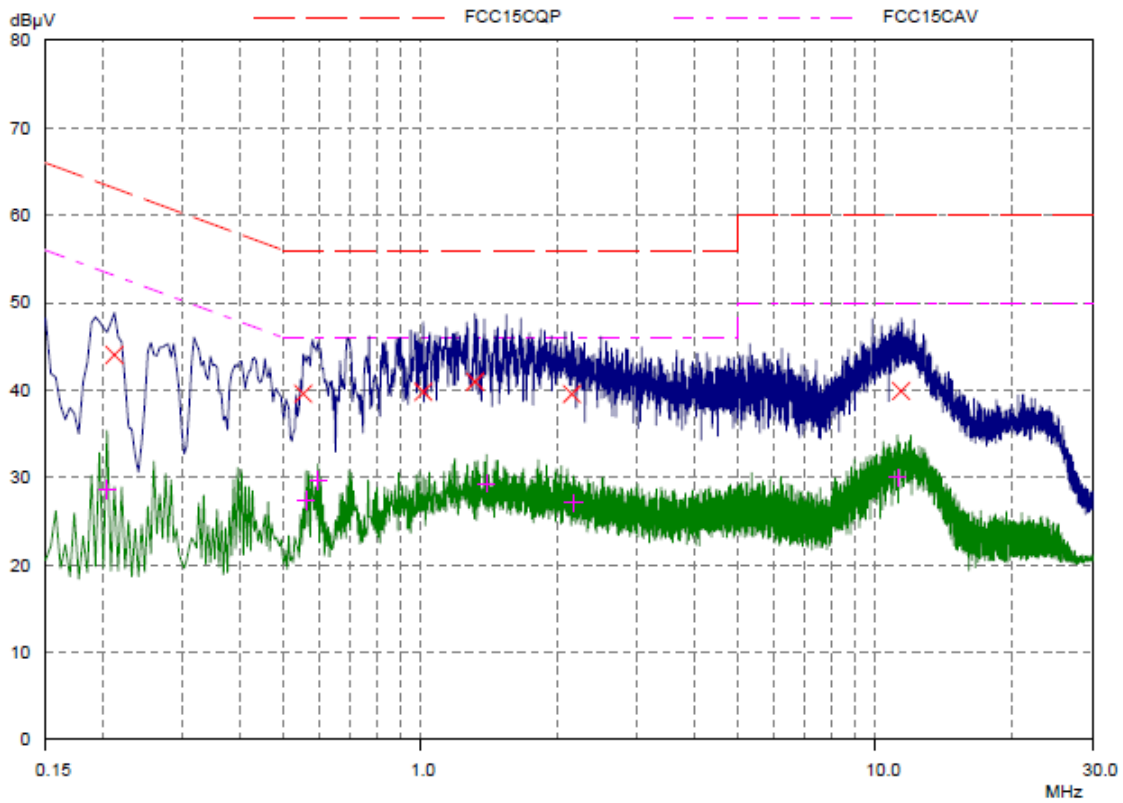

Final Measurement Results

Frequency MHz	QP Level dBµV	QP Limit dBµV	QP Delta dB	Phase -	PE -
0.2125	44.02	63.11	19.09	L1	gnd
0.55234	39.58	56.00	16.42	L1	gnd
1.01328	39.80	56.00	16.20	L1	gnd
1.31796	40.96	56.00	15.04	L1	gnd
2.15	39.54	56.00	16.46	L1	gnd
11.39218	39.90	60.00	20.10	L1	gnd

Frequency MHz	AV Level dBµV	AV Limit dBµV	AV Delta dB	Phase -	PE -
0.20468	28.64	53.42	24.78	L1	gnd
0.56015	27.42	46.00	18.58	L1	gnd
0.59531	29.67	46.00	16.33	L1	gnd
1.39609	29.31	46.00	16.69	L1	gnd
2.16953	27.07	46.00	18.93	L1	gnd
11.18125	30.00	50.00	20.00	L1	gnd

L Line

TA Technology (Shanghai) Co., Ltd. Test Report

Report No.: RXA1507-0129RF01R2

Page 54of 58

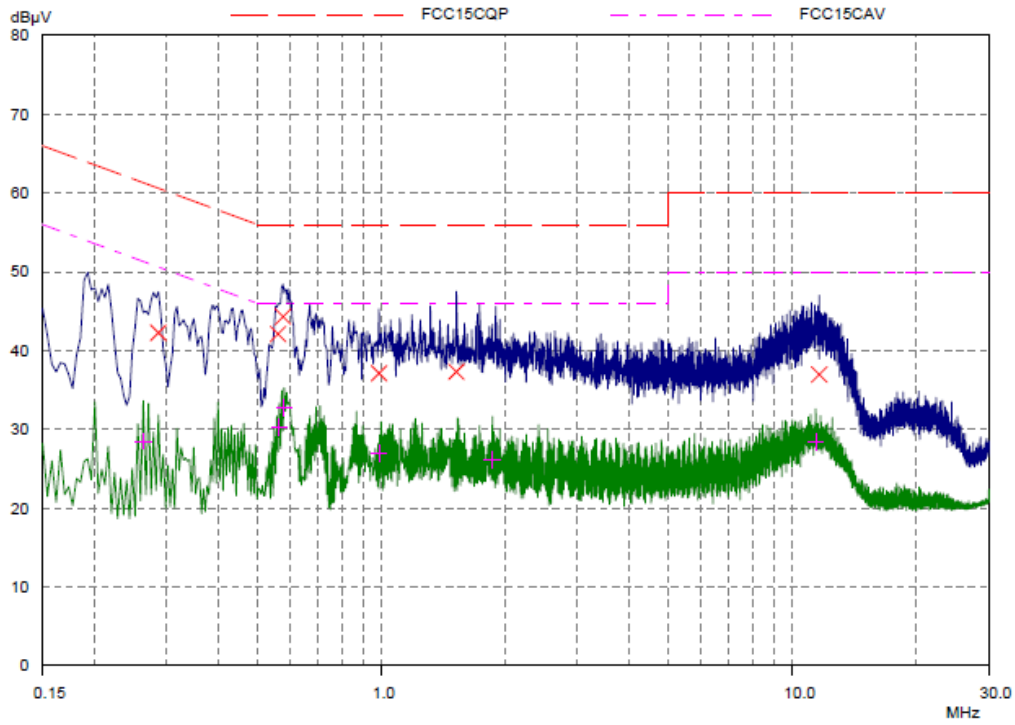

Final Measurement Results

Frequency MHz	QP Level dBµV	QP Limit dBµV	QP Delta dB	Phase -	PE -
0.28671	42.26	60.62	18.36	N	gnd
0.56015	42.10	56.00	13.90	N	gnd
0.57578	44.32	56.00	11.68	N	gnd
0.98593	37.12	56.00	18.88	N	gnd
1.52109	37.32	56.00	18.68	N	gnd
11.60703	36.98	60.00	23.02	N	gnd

Frequency MHz	AV Level dBµV	AV Limit dBµV	AV Delta dB	Phase -	PE -
0.26328	28.49	51.33	22.84	N	gnd
0.56406	30.31	46.00	15.69	N	gnd
0.57968	32.78	46.00	13.22	N	gnd
0.98593	27.01	46.00	18.99	N	gnd
1.86093	26.19	46.00	19.81	N	gnd
11.37265	28.43	50.00	21.57	N	gnd

N Line

TA Technology (Shanghai) Co., Ltd.
Test Report

Report No.: RXA1507-0129RF01R2

Page 55 of 58

3. Main Test Instruments

No	Name	Type	Manufacturer	Serial Number	Calibration Date	Expiration Time	Valid Period
01	Signal Analyzer	FSV30	R&S	100815	2014-12-18	2015-12-17	1 year
02	Loop Antenna	FMZB1519	SCHWARZBECK	1519-047	2014-02-19	2016-02-18	2 years
03	EMI Test Receiver	ESCS30	R&S	100138	2014-12-18	2015-12-17	1 year
04	LISN	ENV216	R&S	101171	2013-12-18	2016-12-17	3 years
05	EMI Test Receiver	ESCI	R&S	100948	2015-05-22	2016-05-21	1 year
06	TRILOG Broadband Antenna	VULB 9163	Schwarzbeck	9163-201	2014-12-06	2017-12-05	3 years
07	Double Ridged Waveguide Horn Antenna	HF907	R&S	100126	2014-12-06	2017-12-05	3 years
08	Spectrum Analyzer	E4445A	Agilent	MY46181146	2015-05-22	2016-05-21	1 year

*****END OF REPORT *****

ANNEX A: EUT Appearance and Test Setup

A.1 EUT Appearance



EUT
Picture 1 EUT

A.2 Test Setup



9kHz-30MHz

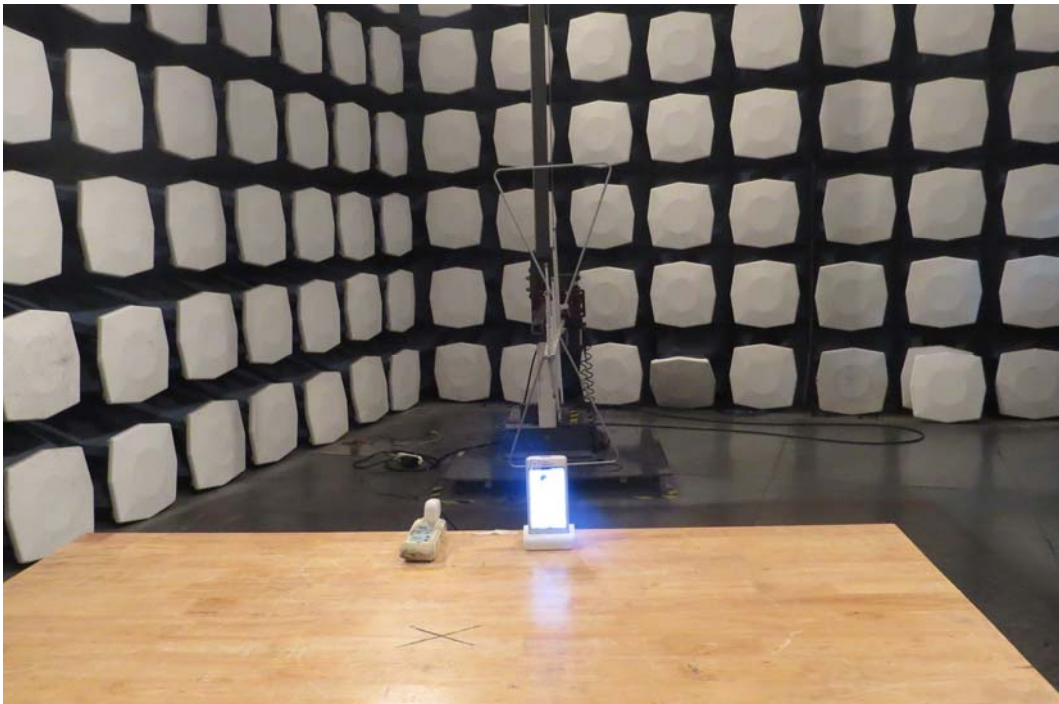

30MHz-1GHz

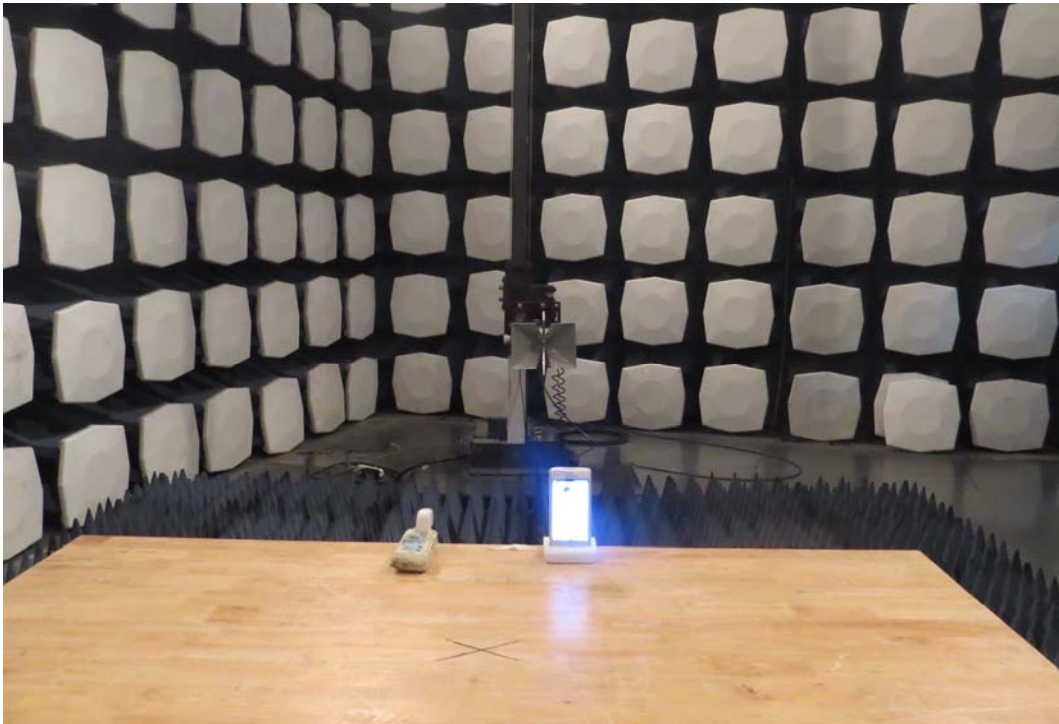

Above 1GHz

Picture 2 Radiated Emission Test Setup



Picture 3 Conducted Emission Test Setup