

TEST REPORT

Product Name : wireless charger power bank
Model Number : SP0381, 7121-43
FCC ID : 2ABHA0123

Prepared for : Ningbo Cstar Imp & Exp CO., LTD
Address : Floor 4,Building E, No. 655-90,Qiming Road, Yinzhou Investment
&Innovation Center, Ningbo, China

Prepared by : EMTEK (DONGGUAN) CO., LTD.
Address : -1&2/F.,Building 2, Zone A, Zhongda Marine Biotechnology
Research and Development Base, No.9, Xincheng Avenue,
Songshanhu High-technology Industrial Development Zone,
Dongguan, Guangdong, China

TEL: +86-0769-22807078
FAX: +86-0769-22807079

Report Number : EDG2302280053E00601R
Date(s) of Tests : February 28, 2023 to March 10, 2023
Date of issue : March 10, 2023

TABLE OF CONTENT

| Test Report Description | Page |
|--|-------------|
| 1. SUMMARY OF TEST RESULTS | 5 |
| 2. GENERAL INFORMATION | 6 |
| 2.1. Description of Device (EUT) | 6 |
| 2.2. Input / Output Ports | 6 |
| 2.3. Independent Operation Modes | 7 |
| 2.4. Test Manner | 7 |
| 2.5. Description of Test Facility | 7 |
| 2.6. Test Software | 7 |
| 2.7. Description of Support Device | 8 |
| 2.8. Measurement Uncertainty | 8 |
| 3. MEASURING DEVICE AND TEST EQUIPMENT | 9 |
| 3.1. Conducted Emission Test Equipment | 9 |
| 3.2. For 3m Radiated Emission Measurement 9K-30M (3m chamber 1#) | 9 |
| 3.3. For 3m Radiated Emission Measurement 30M-1G (3m chamber 1#) | 9 |
| 4. 20DB BANDWIDTH | 10 |
| 4.1. Test Procedure | 10 |
| 4.2. Test Results | 10 |
| 5. POWER LINE CONDUCTED EMISSION MEASUREMENT | 11 |
| 5.1. Block Diagram of Test Setup | 11 |
| 5.2. Limits | 11 |
| 5.3. Test Procedure | 11 |
| 5.4. Measuring Results | 12 |
| 6. RADIATED EMISSION TEST | 15 |
| 6.1. Measurement Procedure | 15 |
| 6.2. Test SET-UP (Block Diagram of Configuration) | 15 |
| 6.3. Measurement Equipment Used | 16 |
| 6.4. Radiated Emission Limit | 16 |
| 6.5. Measurement Result | 18 |
| 7. ANTENNA REQUIREMENT | 21 |

TEST REPORT DESCRIPTION

Applicant : Ningbo Cstar Imp & Exp CO., LTD
 Address : Floor 4, Building E, No. 655-90, Qiming Road, Yinzhou Investment & Innovation Center, Ningbo, China
 Manufacturer : Ningbo Cstar Imp & Exp CO., LTD
 Address : Floor 4, Building E, No. 655-90, Qiming Road, Yinzhou Investment & Innovation Center, Ningbo, China
 EUT : wireless charger power bank
 Model Name : SP0381, 7121-43
 Trademark : N/A

Measurement Procedure Used:

| APPLICABLE STANDARDS | |
|---|-------------|
| STANDARD | TEST RESULT |
| FCC 47 CFR Part 2, Subpart J FCC 47 CFR Part 15, Subpart C | PASS |

The above equipment was tested by DONGGUAN EMTEK CO., LTD. The test data, data evaluation, test procedures, and equipment configurations shown in this report were made in accordance with the procedures given in ANSI C63.10 (2013) and the energy emitted by the sample EUT tested as described in this report is in compliance with conducted and radiated emission limits of FCC Rules Part 15C

The test results of this report relate only to the tested sample identified in this report.

Date of Test : February 28, 2023 to March 10, 2023

Prepared by : Xia Yang

Xia Yang /Editor

Reviewer : Tim Dong

Tim Dong/ Supervisor

Approved & Authorized Signer : Sam Lv

Sam Lv / Manager

Modified Information

| Version | Report No. | Revision Data | Summary |
|---------|----------------------|---------------|------------------|
| | EDG2302280053E00601R | / | Original Version |
| | | | |
| | | | |
| | | | |



1. SUMMARY OF TEST RESULTS

| EMISSION | | |
|--|--|---------|
| Description of Test Item | Standard & Limits | Results |
| Conducted Emission | FCC Part 15, Subpart C- Section 15.207 ANSI C63.10-2013 | Pass |
| Radiated Emission | FCC Part 15, Subpart C- Section 15.209 ANSI C63.10-2013 | Pass |
| Note: N/A is an abbreviation for Not Applicable. | | |



2. GENERAL INFORMATION

2.1. Description of Device (EUT)

EUT : wireless charger power bank

Model Number : SP0381, 7121-43
All products are the same, only the model number are different
Here we selected SP0381 for all the test

Sample number : 2#

Input : DC 5V/1.8-2.4A from USB

Output : DC 5V/2.1A
Wireless 5V/1A

Operation Frequency for WPT : 111KHz-205KHz

Modulation : FSK

Antenna Type: : Induction Coil antenna

Temperature Range : 0~+45°C

Date of Test : February 28, 2023 to March 10, 2023

2.2. Input / Output Ports

| Port # | Name | Type* | Cable Max. >3m | Cable Shielded | Comments |
|--------|------------|-------|----------------|----------------|----------|
| 1 | Enclosure | N/E | -- | -- | None |
| 2 | DC IN port | I/O | No | Unshielded | 1 port |

* Note: For the purposes of the present document, the following symbols apply:

| | |
|-----|---|
| AC | AC Power Port |
| DC | DC Power Port |
| N/E | Non-Electrical |
| I/O | Signal Input or Output Port (Not Involved in Process Control) |
| TP | Telecommunication Ports |

2.3. Independent Operation Modes

- A ON
1. Wireless(100% load)
 2. Wireless(50% load)
 3. Wireless(10% load)
- Note: The mode 1 is the worst mode

2.4. Test Manner

| Test Items | Test Voltage | Operation Modes |
|--------------------|--------------|-----------------|
| Conducted Emission | AC 120V/60Hz | Mode A.1 |
| Radiated Emission | AC 120V/60Hz | Mode A.1 |

2.5. Description of Test Facility

Site Description

EMC Lab. : Accredited by CNAS, 2020.08.27
 The certificate is valid until 2024.07.05
 The Laboratory has been assessed and proved to be in compliance with
 CNAS/CL01:2018
 The Certificate Registration Number is L3150

Accredited by FCC
 Designation Number: CN1300
 Test Firm Registration Number: 945551

Accredited by A2LA, April 05, 2021
 The Certificate Registration Number is 4321.02

Accredited by Industry Canada
 The Certificate Registration Number is CN0113

Name of Firm : EMTEK(DONGGUAN) CO., LTD.
 Site Location : -1&2/F., Buiding 2, Zone A, Zhongda Marine Biotechnology Research and
 Development Base, N.9, Xincheng Avenue, Songshanhu High-technology
 Industrial Development Zone, Dongguan, Guangdong, China

2.6. Test Software

| Item | Software |
|--------------------|-----------------------|
| Conducted Emission | : EMTEK(Ver.CON-03A1) |
| Radiated Emission | : EMTEK(Ver.RA-03A1) |

2.7. Description of Support Device

| No. | Equipment | Trade name | Model | S/N | Power Cord |
|-----|---------------|------------|-------|-----|------------|
| 1. | Wireless Load | N/A | 5w | N/A | N/A |
| 2. | Adapter | Apple | A1695 | N/A | N/A |

2.8. Measurement Uncertainty

| Test Item | Uncertainty |
|---|---|
| Conducted Emission Uncertainty | 3.16dB(9k~150kHz Conduction 2#) 2.90dB(150k-30MHz Conduction 2#) |
| Radiated Emission Uncertainty (3m Chamber) | 3.78dB (30M~1GHz Polarize: H) 4.27dB (30M~1GHz Polarize: V) 4.46dB (1~6GHz) |



3. MEASURING DEVICE AND TEST EQUIPMENT

3.1. Conducted Emission Test Equipment

| EQUIPMENT TYPE | MFR | MODEL NUMBER | SERIAL NUMBER | LAST CAL. | DUE CAL. |
|--------------------|-----------------|--------------|---------------|------------|------------|
| Test Receiver | Rohde & Schwarz | ESCS30 | 828985/018 | 05/20/2022 | 05/19/2023 |
| L.I.S.N. | Schwarzbeck | NNLK8129 | 8129203 | 05/20/2022 | 05/19/2023 |
| 50Ω Coaxial Switch | Anritsu | MP59B | M20531 | 05/20/2022 | 05/19/2023 |
| Pulse Limiter | Rohde & Schwarz | ESH3-Z2 | 100006 | 05/20/2022 | 05/19/2023 |
| Voltage Probe | Rohde & Schwarz | TK9416 | N/A | 05/20/2022 | 05/19/2023 |
| I.S.N | Rohde & Schwarz | ENY22 | 1109.9508.02 | 05/20/2022 | 05/19/2023 |

3.2. For 3m Radiated Emission Measurement 9K-30M (3m chamber 1#)

| Equipment | Manufacturer | Model No. | Serial No. | Last Cal. | DUE CAL. |
|-------------------|-----------------|------------------|--------------|------------|------------|
| EMI Test Receiver | Rohde & Schwarz | ESU | 1302.6005.26 | 05/20/2022 | 05/19/2023 |
| Loop Antenna | Schwarzbeck | FMZB 1519 | 1519-012 | 05/20/2022 | 05/19/2023 |
| Cable | / | 3M SF104-26.5 | 295838/4 | 05/20/2022 | 05/19/2023 |
| Cable | / | 6M SF104-26.5 | 295840/4 | 05/20/2022 | 05/19/2023 |

3.3. For 3m Radiated Emission Measurement 30M-1G (3m chamber 1#)

| Equipment | Manufacturer | Model No. | Serial No. | Last Cal. | Cal. Interval |
|-------------------|-----------------|-----------|--------------|------------|---------------|
| EMI Test Receiver | Rohde & Schwarz | ESU | 1302.6005.26 | 05/20/2022 | 05/19/2023 |
| Pre-Amplifier | HP | 8447F | 2944A07999 | 05/20/2022 | 05/19/2023 |
| Bilog Antenna | Schwarzbeck | VULB9163 | 142 | 05/20/2022 | 05/19/2023 |
| Cable | Schwarzbeck | AK9513 | ACRX1 | 05/20/2022 | 05/19/2023 |
| Cable | Rosenberger | N/A | FP2RX2 | 05/20/2022 | 05/19/2023 |
| Cable | Schwarzbeck | AK9513 | CRPX1 | 05/20/2022 | 05/19/2023 |
| Cable | Schwarzbeck | AK9513 | CRRX2 | 05/20/2022 | 05/19/2023 |

4. 20DB BANDWIDTH

4.1. Test Procedure

Set to the maximum power setting and enable the EUT transmit continuously
 Set RBW = 3Hz.
 Set the video bandwidth (VBW) =10Hz.
 Set Span= 300Hz
 Set Detector = Peak.
 Set Trace mode = max hold.
 Set Sweep = auto couple.
 Measure and record the results in the test report.

4.2. Test Results

Temperature: 24°C Test Date: 2022/03/04
 Humidity: 53 % Test By: Xia
 20dB Band=91.61 Hz

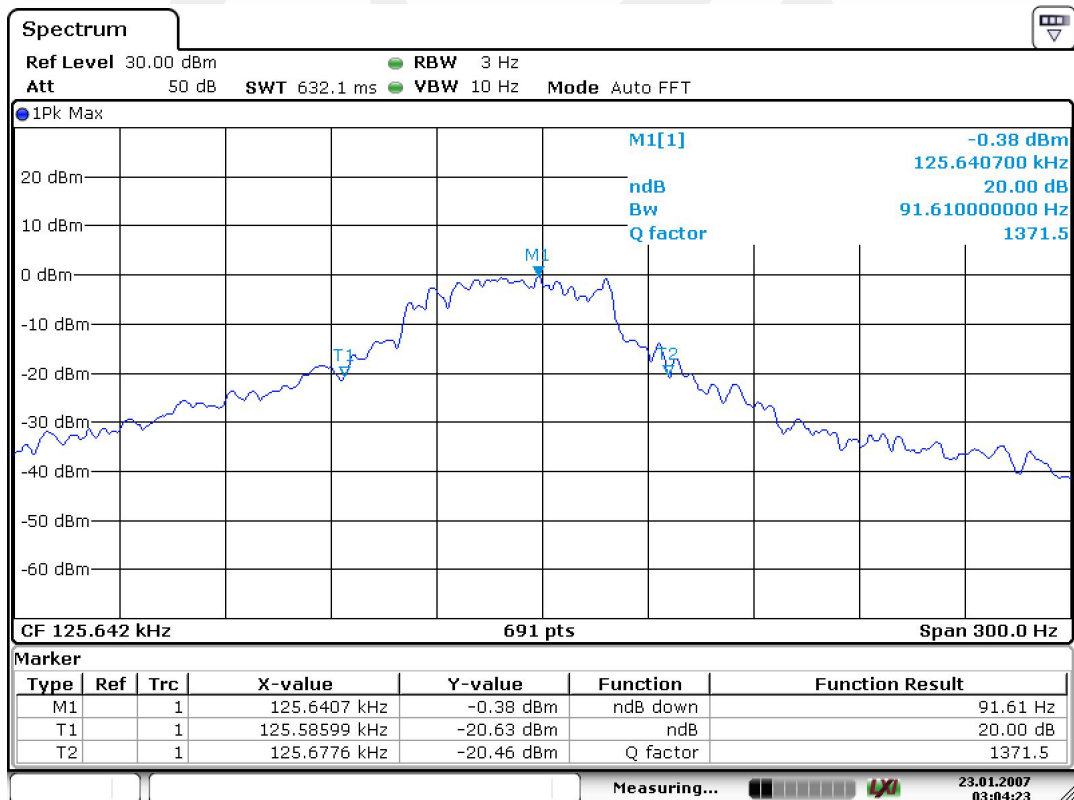

5. POWER LINE CONDUCTED EMISSION MEASUREMENT

5.1. Block Diagram of Test Setup

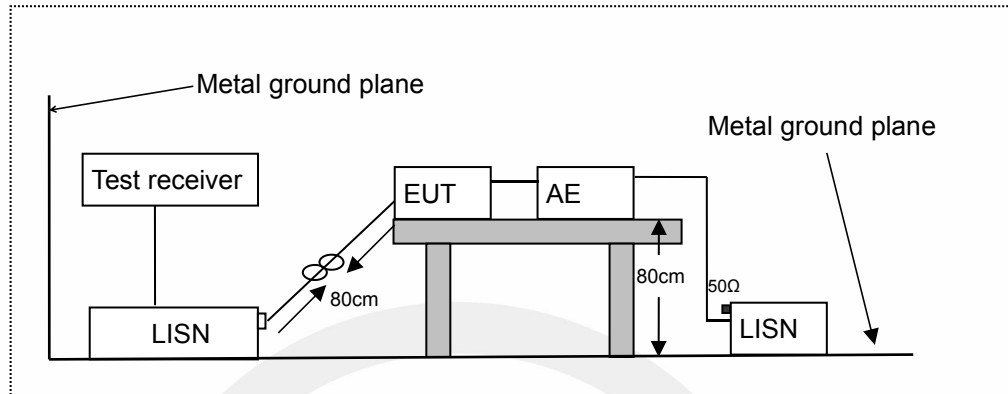

LISN: Line Impedance Stabilization Network
 AE: Associated equipment
 EUT: Equipment under test

5.2. Limits

FCC Part 15.207

| Frequency (MHz) | Limit (dB μ V) | |
|-----------------|--------------------|---------------|
| | Quasi-peak Level | Average Level |
| 0.15 ~ 0.50 | 66.0 ~ 56.0 * | 56.0 ~ 46.0 * |
| 0.50 ~ 5.00 | 56.0 | 46.0 |
| 5.00 ~ 30.00 | 60.0 | 50.0 |

NOTE1-The lower limit shall apply at the transition frequencies.
 NOTE2-The limit decreases linearly with the logarithm of the frequency in the range 0.15MHz to 0.50MHz.

5.3. Test Procedure

The EUT was placed on a desk 0.8 m height from the metal ground plane and 0.4 m from the conducting wall of the shielding room and it was kept at least 0.8 m from any other grounded conducting surface. The size of the table will nominally be 1.5 m x1.0 m.

The rear of the arrangement shall be flush with the back of the supporting tabletop unless that would not be possible or typical of normal use.

All units of equipment forming the system under test (includes the EUT as well as connected peripherals and associated equipment or devices) shall be arranged such that a nominal 0.1 m separation is achieved between the neighboring units.

Connect EUT to the power mains through a line impedance stabilization network (LISN). Where the mains cable supplied by the manufacturer is longer than 1 m, the excess should be folded at the centre into a bundle no longer than 0.4 m, so that its length is shortened to 1 m.

All the support units are connecting to the other LISN.

The LISN provides 50 ohm coupling impedance for the measuring instrument.

Both sides of AC line were checked for maximum conducted interference.

The frequency range from 150 kHz to 30 MHz was sweep.

Set the test-receiver system to quasi peak detect function and average detect function, and to measure the conducted emissions values.

Test results were obtained from the following equation:

Emission Level (dB μ V) = LISN Factor (dB) + Cable Loss (dB) + Reading (dB μ V)

Margin (dB) = Emission Level (dB μ V) - Limit (dB μ V)

5.4. Measuring Results

PASS.



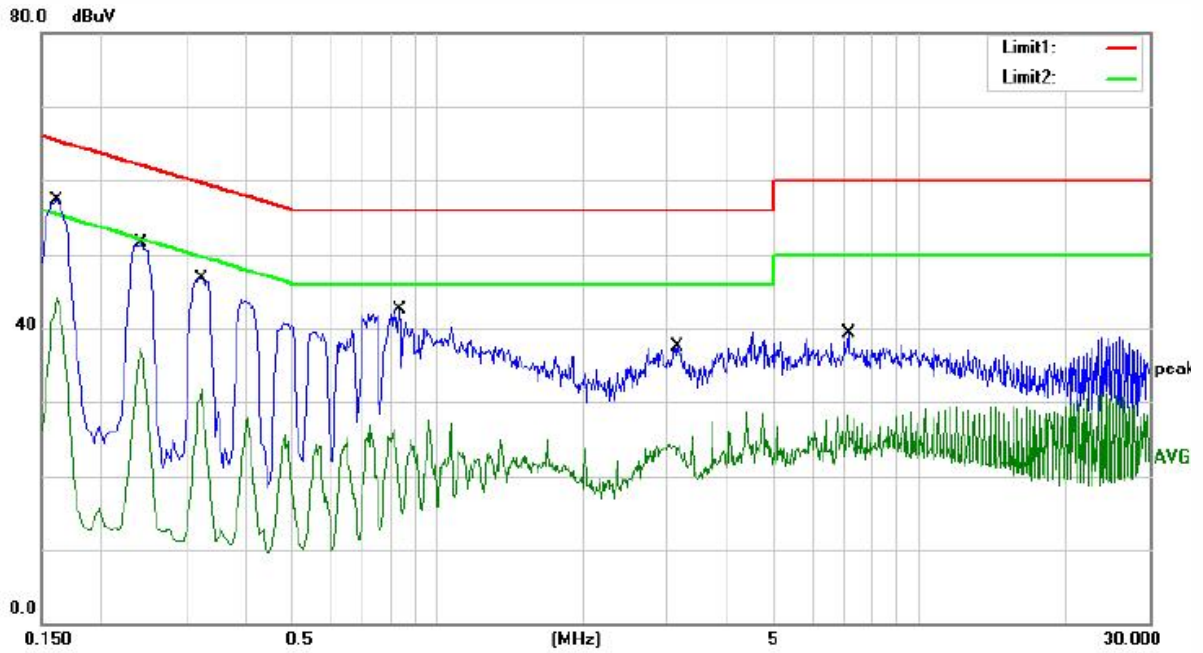

Site site #1 Phase: **L1** Temperature: 21.4

Mode: Wireless Charging
Note:

| No. | Mk. | Freq. MHz | Reading Level dBuV | Correct Factor dB | Measure- ment dBuV | Limit dBuV | Over dB | Detector | Comment |
|-----|-----|--------------|--------------------------|-------------------------|--------------------------|---------------|------------|----------|---------|
| 1 | * | 0.1620 | 46.84 | 10.52 | 57.36 | 65.36 | -8.00 | QP | |
| 2 | | 0.1620 | 33.53 | 10.52 | 44.05 | 55.36 | -11.31 | AVG | |
| 3 | | 0.2420 | 41.05 | 10.43 | 51.48 | 62.03 | -10.55 | QP | |
| 4 | | 0.2420 | 26.85 | 10.43 | 37.28 | 52.03 | -14.75 | AVG | |
| 5 | | 0.3220 | 36.43 | 10.33 | 46.76 | 59.66 | -12.90 | QP | |
| 6 | | 0.3220 | 21.32 | 10.33 | 31.65 | 49.66 | -18.01 | AVG | |
| 7 | | 0.8340 | 32.31 | 10.12 | 42.43 | 56.00 | -13.57 | QP | |
| 8 | | 0.8340 | 16.25 | 10.12 | 26.37 | 46.00 | -19.63 | AVG | |
| 9 | | 3.1540 | 27.41 | 10.08 | 37.49 | 56.00 | -18.51 | QP | |
| 10 | | 3.1540 | 14.22 | 10.08 | 24.30 | 46.00 | -21.70 | AVG | |
| 11 | | 7.1100 | 29.26 | 10.05 | 39.31 | 60.00 | -20.69 | QP | |
| 12 | | 7.1100 | 18.23 | 10.05 | 28.28 | 50.00 | -21.72 | AVG | |

*:Maximum data x:Over limit l:over margin Comment: Factor build in receiver. Operator:

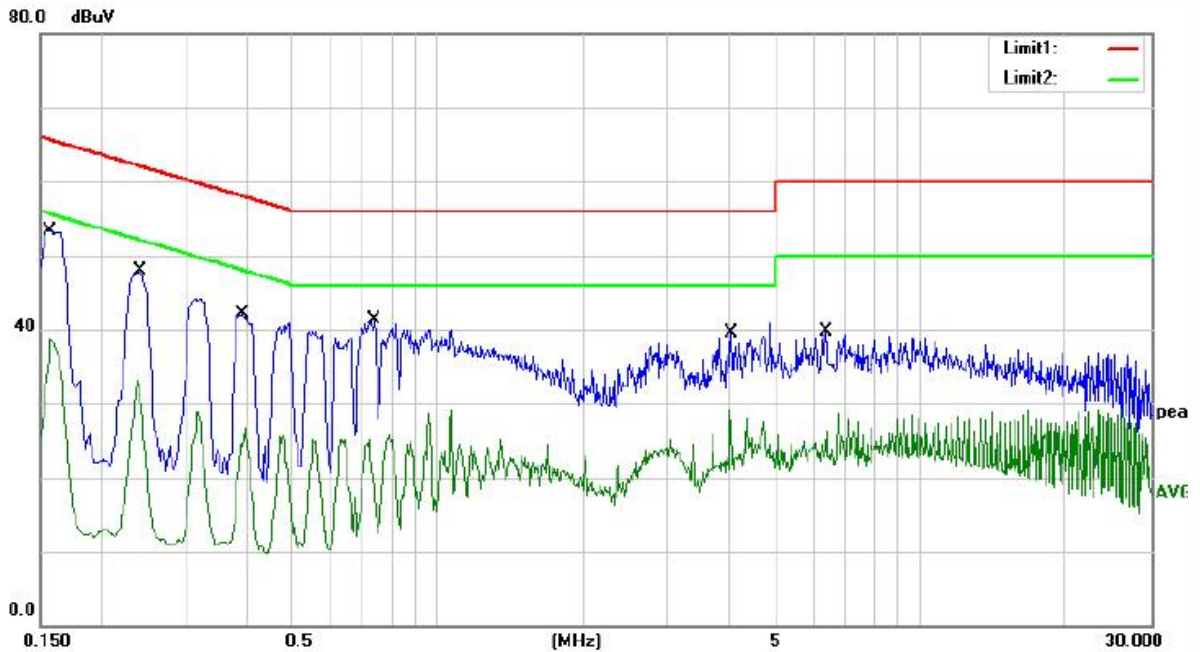

Site site #1 Phase: **N** Temperature: 21.4

Mode: Wireless Charging

Note:

| No. | Mk. | Freq. MHz | Reading Level dBuV | Correct Factor dB | Measure- ment dBuV | Limit dBuV | Over dB | Detector | Comment |
|-----|-----|--------------|--------------------------|-------------------------|--------------------------|---------------|------------|----------|---------|
| 1 | * | 0.1580 | 42.72 | 10.52 | 53.24 | 65.57 | -12.33 | QP | |
| 2 | | 0.1580 | 28.11 | 10.52 | 38.63 | 55.57 | -16.94 | AVG | |
| 3 | | 0.2420 | 37.41 | 10.43 | 47.84 | 62.03 | -14.19 | QP | |
| 4 | | 0.2420 | 22.73 | 10.43 | 33.16 | 52.03 | -18.87 | AVG | |
| 5 | | 0.3940 | 31.83 | 10.25 | 42.08 | 57.98 | -15.90 | QP | |
| 6 | | 0.3940 | 16.43 | 10.25 | 26.68 | 47.98 | -21.30 | AVG | |
| 7 | | 0.7420 | 31.18 | 10.13 | 41.31 | 56.00 | -14.69 | QP | |
| 8 | | 0.7420 | 14.92 | 10.13 | 25.05 | 46.00 | -20.95 | AVG | |
| 9 | | 4.0500 | 29.45 | 10.07 | 39.52 | 56.00 | -16.48 | QP | |
| 10 | | 4.0500 | 19.05 | 10.07 | 29.12 | 46.00 | -16.88 | AVG | |
| 11 | | 6.3820 | 29.75 | 10.05 | 39.80 | 60.00 | -20.20 | QP | |
| 12 | | 6.3820 | 16.30 | 10.05 | 26.35 | 50.00 | -23.65 | AVG | |

*:Maximum data x:Over limit !:over margin Comment: Factor build in receiver. Operator:

6. RADIATED EMISSION TEST

6.1. Measurement Procedure

1. The EUT was placed on a turn table which is 0.8m above ground plane.
2. Maximum procedure was performed on the six highest emissions to ensure EUT compliance.
3. And also, each emission was to be maximized by changing the polarization of receiving antenna both horizontal and vertical.
4. Repeat above procedures until all frequency measured were complete.
5. Use the following receiver/spectrum analyzer settings:
 Span = wide enough to fully capture the emission being measured
 RBW=200Hz for 9KHz to 150KHz,
 RBW=9kHz for 150KHz to 30MHz,
 RBW=120KHz for 30MHz to 1GHz
 VBW $\geq 3 \times$ RBW
 Sweep = auto
 Detector function = QP
 Trace = max hold

6.2. Test SET-UP (Block Diagram of Configuration)

(A) Radiated Emission Test Set-Up, Frequency Below 30MHz

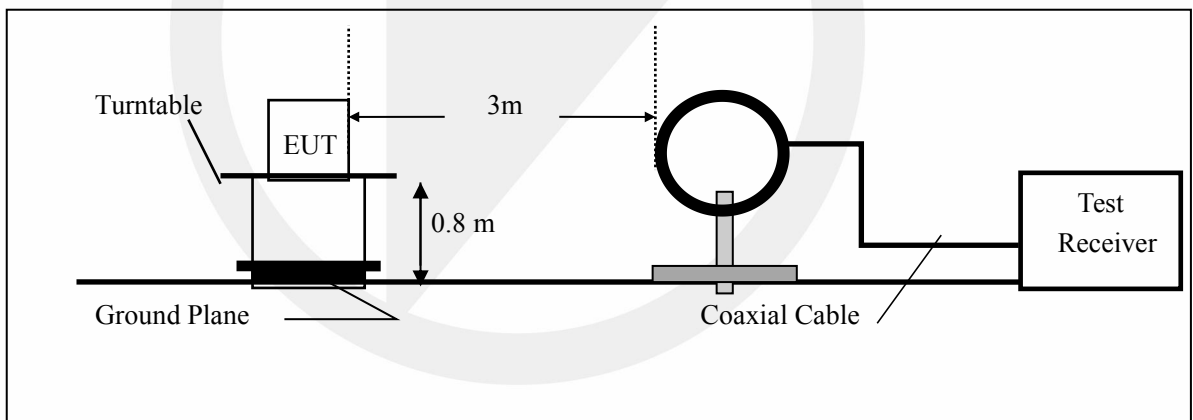

(B) Radiated Emission Test Set-Up, Frequency Below 1000MHz

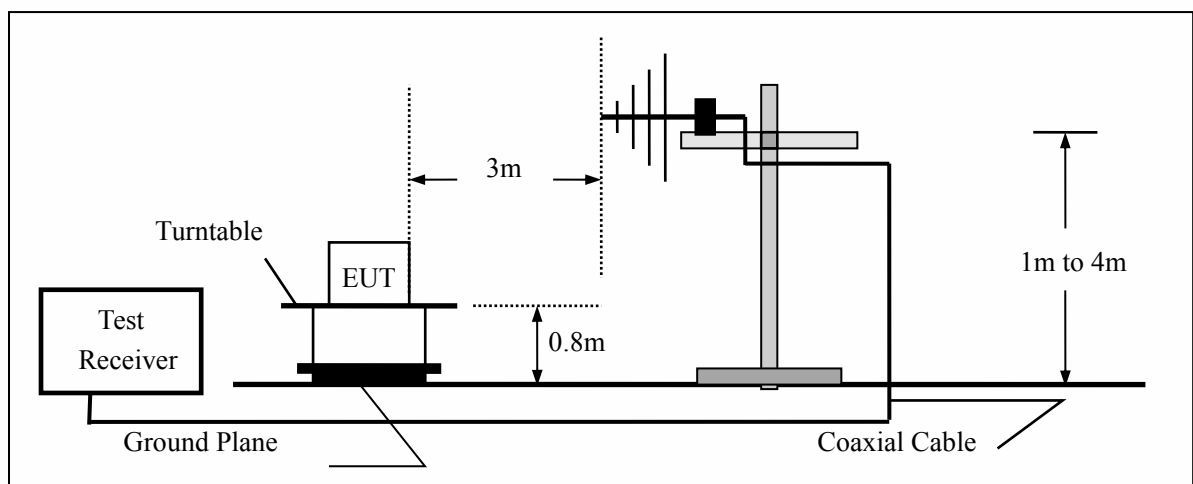

6.3.Measurement Equipment Used

| EQUIPMENT TYPE | MFR | MODEL NUMBER | SERIAL NUMBER | LAST CAL. | CAL DUE. |
|-------------------|-----------------|--------------|---------------|------------|------------|
| EMI Test Receiver | Rohde & Schwarz | ESU | 1302.6005.26 | 05/20/2022 | 05/19/2023 |
| Pre-Amplifier | HP | 8447D | 2944A07999 | 05/20/2022 | 05/19/2023 |
| Bilog Antenna | Schwarzbeck | VULB9163 | 142 | 05/20/2022 | 05/19/2023 |
| Loop Antenna | ARA | PLA-1030/B | 1029 | 05/20/2022 | 05/19/2023 |
| Horn Antenna | Schwarzbeck | BBHA 9170 | BBHA9170399 | 05/20/2022 | 05/19/2023 |
| Horn Antenna | Schwarzbeck | BBHA 9120 | D143 | 05/20/2022 | 05/19/2023 |
| Cable | Schwarzbeck | AK9513 | ACRX1 | 05/20/2022 | 05/19/2023 |
| Cable | Rosenberger | N/A | FP2RX2 | 05/20/2022 | 05/19/2023 |
| Cable | Schwarzbeck | AK9513 | CRPX1 | 05/20/2022 | 05/19/2023 |
| Cable | Schwarzbeck | AK9513 | CRRX2 | 05/20/2022 | 05/19/2023 |

6.4.Radiated Emission Limit

The emissions from an intentional radiator shall not exceed the field strength levels specified in the following table 15.209(a):

| FCC Part 15.209 | | | | |
|-----------------|---------------------------|------|---|-------------------------|
| Frequency (MHz) | Field Strength Limitation | | Field Strength Limitation Frequency tion at 3m Measurement Dist | |
| | (uV/m) | Dist | (uV/m) | (dBuV/m) |
| 0.009 – 0.490 | 2400 / F(KHz) | 300m | 10000 * 2400/F(KHz) | 20log 2400/F(KHz) + 80 |
| 0.490 – 1.705 | 24000 / F(KHz) | 30m | 100 * 24000/F(KHz) | 20log 24000/F(KHz) + 40 |
| 1.705 – 30.00 | 30 | 30m | 100* 30 | 20log 30 + 40 |
| 30.0 – 88.0 | 100 | 3m | 100 | 20log 100 |
| 88.0 – 216.0 | 150 | 3m | 150 | 20log 150 |
| 216.0 – 960.0 | 200 | 3m | 200 | 20log 200 |
| Above 960.0 | 500 | 3m | 500 | 20log 500 |

15.205 Restricted bands of operation

| MHz | MHz | MHz | GHz |
|----------------------------|-----------------------|-----------------|------------------|
| 0.090 - 0.110 | 16.42 - 16.423 | 399.9 - 410 | 4.5 - 5.15 |
| ¹ 0.495 - 0.505 | 16.69475 - 16.69525 | 608 - 614 | 5.35 - 5.46 |
| 2.1735 - 2.1905 | 16.80425 - 16.80475 | 960 - 1240 | 7.25 - 7.75 |
| 4.125 - 4.128 | 25.5 - 25.67 | 1300 - 1427 | 8.025 - 8.5 |
| 4.17725 - 4.17775 | 37.5 - 38.25 | 1435 - 1626.5 | 9.0 - 9.2 |
| 4.20725 - 4.20775 | 73 - 74.6 | 1645.5 - 1646.5 | 9.3 - 9.5 |
| 6.215 - 6.218 | 74.8 - 75.2 | 1660 - 1710 | 10.6 - 12.7 |
| 6.26775 - 6.26825 | 108 - 121.94 | 1718.8 - 1722.2 | 13.25 - 13.4 |
| 6.31175 - 6.31225 | 123 - 138 | 2200 - 2300 | 14.47 - 14.5 |
| 8.291 - 8.294 | 149.9 - 150.05 | 2310 - 2390 | 15.35 - 16.2 |
| 8.362 - 8.366 | 156.52475 - 156.52525 | 2483.5 - 2500 | 17.7 - 21.4 |
| 8.37625 - 8.38675 | 156.7 - 156.9 | 2690 - 2900 | 22.01 - 23.12 |
| 8.41425 - 8.41475 | 162.0125 - 167.17 | 3260 - 3267 | 23.6 - 24.0 |
| 12.29 - 12.293 | 167.72 - 173.2 | 3332 - 3339 | 31.2 - 31.8 |
| 12.51975 - 12.52025 | 240 - 285 | 3345.8 - 3358 | 36.43 - 36.5 |
| 12.57675 - 12.57725 | 322 - 335.4 | 3600 - 4400 | (²) |

- Remark:
1. Emission level in dBuV/m=20 log (uV/m)
 2. Measurement was performed at an antenna to the closed point of EUT distance of meters.
 3. Only spurious frequency is permitted to locate within the Restricted Bands specified in provision of § 15.205, and the emissions located in restricted bands also comply with 15.209 limit.

6.5.Measurement Result

| | | | |
|--------------------|---------------|---------------|------------|
| Operation Mode: | Low frequency | Test Date : | 2023/03/04 |
| Frequency Range: | 9KHz~30MHz | Temperature : | 20℃ |
| Test Result: | PASS | Humidity : | 55 % |
| Measured Distance: | 3m | Test By: | Xia |

| Freq. (MHz) | Ant.Pol. H/V | Emission Level (dBuV/m) | Limit 3m (dBuV/m) | Over (dB) | Note |
|----------------|-----------------|----------------------------|----------------------|--------------|------|
| 0.1140 | H | 88.06 | 106.47 | -18.41 | PK |
| 0.1840 | H | 65.90 | 102.31 | -36.41 | PK |
| 0.2482 | H | 62.56 | 99.71 | -37.15 | PK |
| 0.3271 | H | 60.67 | 97.31 | -36.64 | PK |
| 0.4910 | H | 57.06 | 73.78 | -16.72 | PK |
| 0.6310 | H | 52.40 | 71.60 | -19.20 | PK |
| | | | | | |
| 0.1150 | V | 88.23 | 106.39 | -18.16 | PK |
| 0.1853 | V | 65.42 | 102.25 | -36.83 | PK |
| 0.3113 | V | 61.26 | 97.74 | -36.48 | PK |
| 0.4072 | V | 57.09 | 95.41 | -38.32 | PK |
| 0.5191 | V | 54.82 | 73.30 | -18.48 | PK |
| 0.7858 | V | 51.29 | 69.70 | -18.41 | PK |

- Note:** (1) All Readings are Peak Value.
 (2) Emission Level= Reading Level+Probe Factor +Cable Loss.
 (3) The average measurement was not performed when the peak measured data under the limit of average detection.
 (4) EUT lying on the table position is the worst case result in the report.

30MHz-1GHz:



Site: Chamber #1 Polarization: **Horizontal** Temperature: 21.8

Mode: Wireless Charging

Note:

| No. | Mk. | Freq. MHz | Reading Level dBuV | Correct Factor dB | Measure- ment dBuV/m | Limit dBuV/m | Over dB | Detector | Antenna Height cm | Table Degree | Comment |
|-----|-----|--------------|--------------------------|-------------------------|----------------------------|-----------------|------------|----------|-------------------------|-----------------|---------|
| 1 | | 58.0007 | 39.29 | -16.02 | 23.27 | 40.00 | -16.73 | QP | | | |
| 2 | | 122.8340 | 56.74 | -19.32 | 37.42 | 43.50 | -6.08 | QP | | | |
| 3 | ! | 142.8240 | 59.23 | -20.12 | 39.11 | 43.50 | -4.39 | QP | | | |
| 4 | * | 170.1948 | 58.57 | -18.35 | 40.22 | 43.50 | -3.28 | QP | | | |
| 5 | | 232.5318 | 49.45 | -14.46 | 34.99 | 46.00 | -11.01 | QP | | | |
| 6 | | 262.8955 | 45.21 | -13.54 | 31.67 | 46.00 | -14.33 | QP | | | |

*:Maximum data x:Over limit !:over margin

Operator: Ccyf



Site Chamber #1

Polarization: **Vertical**

Temperature: 21.8

Mode: Wireless Charging

Note:

| No. | Mk. | Freq. MHz | Reading Level dBuV | Correct Factor dB | Measure- ment dBuV/m | Limit dBuV/m | Over dB | Antenna Height cm | Table Degree | Comment |
|-----|-----|--------------|--------------------------|-------------------------|----------------------------|-----------------|------------|-------------------------|-----------------|---------|
| 1 | | 43.5056 | 46.47 | -15.80 | 30.67 | 40.00 | -9.33 | | | QP |
| 2 | | 113.7142 | 52.53 | -18.03 | 34.50 | 43.50 | -9.00 | | | QP |
| 3 | ! | 125.4457 | 58.48 | -19.63 | 38.85 | 43.50 | -4.65 | | | QP |
| 4 | * | 146.8875 | 60.14 | -19.89 | 40.25 | 43.50 | -3.25 | | | QP |
| 5 | | 185.1377 | 51.66 | -17.24 | 34.42 | 43.50 | -9.08 | | | QP |
| 6 | | 227.6905 | 45.47 | -14.64 | 30.83 | 46.00 | -15.17 | | | QP |

*:Maximum data x:Over limit !:over margin

Operator: Ccyf

7. ANTENNA REQUIREMENT

The EUT's antenna, permanent attached antenna, used an Induction coil, The antenna's gain meets the requirement.



*** End of Report ***

声明

Statement

1. 本报告无授权批准人签字及“检验报告专用章”无效；

This report will be void without authorized signature or special seal for testing report.

2. 未经许可本报告不得部分复制；

This report shall not be copied partly without authorization.

3. 本报告的检测结果仅对送测样品有效，委托方对样品的代表性和资料的真实性负责；

The test results or observations are applicable only to tested sample. Client shall be responsible for representativeness of the sample and authenticity of the material.

4. 本检测报告中检测项目标注有特殊符号则该项目不在资质认定范围内，仅作为客户委托、科研、教学或内部质量控制等目的使用；

The observations or tests with special mark fall outside the scope of accreditation, and are only used for purpose of commission, research, training, internal quality control etc.

5. 本检测报告以实测值进行符合性判定，未考虑不确定度所带来的风险，本实验室不承担相关责任，特别约定、标准或规范中有明确规定的除外；

The test results or observations are provided in accordance with measured value, without taking risks caused by uncertainty into account. Without explicit stipulation in special agreements, standards or regulations, EMTEK shall not assume any responsibility.

6. 对本检测报告若有异议，请于收到报告之日起 20 日内提出；

Objections shall be raised within 20 days from the date receiving the report.