

**ELECTROMAGNETIC EMISSIONS COMPLIANCE REPORT  
INTENTIONAL RADIATOR CERTIFICATION TO  
FCC PART 15 SUBPART C REQUIREMENT**

*OF*

**CD/USB/SD/MP3/WMA DIGITAL MEDIA RECEVIER**

**Model No.: CZ105BT**

**Trade Mark: Clarion**

**FCC ID: 2ABGY-CZ105BT**

**Report No.: KAD141119067E**

**Issue Date: September 25, 2015**

*Prepared for*

**Electronica Clarion S.A. de C.V.  
Av. 3 y esq. Calle 9 S/N, Zona Industrial, San Juan del Rio, Queretaro,  
Mexico**

*Prepared by*

**DONGGUAN EMTEK CO., LTD.**

**No.281, Guantai Road, Nancheng District,  
Dongguan, Guangdong, China  
TEL: 86-769-22807078  
FAX: 86-769-22807079**

**This report shall not be reproduced, except in full, without the written approval of  
DONGGUAN EMTEK CO., LTD.**

**VERIFICATION OF COMPLIANCE**

Applicant:	Electronica Clarion S.A. de C.V. Av. 3 y esq. Calle 9 S/N, Zona Industrial, San Juan del Rio, Queretaro, Mexico
Manufacturer:	Electronica Clarion S.A. de C.V. Av. 3 y esq. Calle 9 S/N, Zona Industrial, San Juan del Rio, Queretaro, Mexico
Product Description:	CD/USB/SD/MP3/WMA DIGITAL MEDIA RECEVIER
Trade Mark:	Clarion
Model Number:	CZ105BT
Kind of Device:	Bluetooth Ver.2.1+EDR
Date of Test:	November 19, 2014 to September 25, 2015

**We hereby certify that:**

The above equipment was tested by DONGGUAN EMTEK CO., LTD. The test data, data evaluation, test procedures, and equipment configurations shown in this report were made in accordance with the procedures given in ANSI C63.10 (2013) and the energy emitted by the sample EUT tested as described in this report is in compliance with conducted and radiated emission limits of FCC Rules Part 15.247(2014).

***Approved By***



---

**Sam Lv / Q.A. Manager  
DONGGUAN EMTEK CO., LTD.**

### Modified Information

Version	Summary	Revision Date	Report No.
Ver.1.0	Original Report	/	KAD141119067E

## Table of Contents

<b>1. GENERAL INFORMATION .....</b>	<b>6</b>
1.1 PRODUCT DESCRIPTION.....	6
1.2 RELATED SUBMITTAL(S) / GRANT (S).....	6
1.3 TEST METHODOLOGY.....	6
1.4 SPECIAL ACCESSORIES.....	6
1.5 EQUIPMENT MODIFICATIONS .....	6
1.6 TEST FACILITY .....	7
<b>2. SYSTEM TEST CONFIGURATION.....</b>	<b>8</b>
2.1 EUT CONFIGURATION.....	8
2.2 EUT EXERCISE.....	8
2.3 TEST PROCEDURE .....	8
2.4 CONFIGURATION OF TESTED SYSTEM .....	9
<b>3. SUMMARY OF TEST RESULTS .....</b>	<b>10</b>
<b>4. DESCRIPTION OF TEST MODES .....</b>	<b>10</b>
<b>5. RADIATED EMISSION TEST.....</b>	<b>11</b>
5.1 MEASUREMENT PROCEDURE .....	11
5.2 TEST SET-UP (BLOCK DIAGRAM OF CONFIGURATION).....	12
5.3 MEASUREMENT EQUIPMENT USED: .....	13
5.4 MEASUREMENT RESULT.....	14
5.5 RADIATED MEASUREMENT PHOTOS: .....	23
<b>6. CHANNEL SEPARATION TEST.....</b>	<b>24</b>
6.1 MEASUREMENT PROCEDURE .....	24
6.2 TEST SET-UP (BLOCK DIAGRAM OF CONFIGURATION).....	24
6.3 MEASUREMENT EQUIPMENT USED: .....	24
6.4 MEASUREMENT RESULTS:.....	24
<b>7. 20DB BANDWIDTH TEST .....</b>	<b>31</b>
7.1 MEASUREMENT PROCEDURE .....	31
7.2 TEST SET-UP (BLOCK DIAGRAM OF CONFIGURATION).....	31
7.3 MEASUREMENT EQUIPMENT USED: .....	31
7.4 MEASUREMENT RESULTS:.....	31
<b>8. QUANTITY OF HOPPING CHANNEL TEST .....</b>	<b>38</b>
8.1 MEASUREMENT PROCEDURE .....	38
8.2 TEST SET-UP (BLOCK DIAGRAM OF CONFIGURATION).....	38
8.3 MEASUREMENT EQUIPMENT USED: .....	38
8.4 MEASUREMENT RESULTS:.....	38
<b>9. TIME OF OCCUPANCY (DWELL TIME) TEST .....</b>	<b>39</b>

9.1 TEST DESCRIPTION ..... 39

9.2 TEST SET-UP (BLOCK DIAGRAM OF CONFIGURATION)..... 39

9.3 MEASUREMENT EQUIPMENT USED: ..... 39

9.4 TEST REQUIREMENTS / LIMITS ..... 39

9.3 TEST PROTOCOL..... 40

**10. MAXIMUM PEAK OUTPUT POWER TEST ..... 42**

10.1 MEASUREMENT PROCEDURE ..... 42

10.2 TEST SET-UP (BLOCK DIAGRAM OF CONFIGURATION)..... 42

10.3 MEASUREMENT EQUIPMENT USED: ..... 42

10.4 MEASUREMENT RESULTS:..... 43

**11. BAND EDGE TEST ..... 49**

11.1 MEASUREMENT PROCEDURE ..... 49

11.2 TEST SET-UP (BLOCK DIAGRAM OF CONFIGURATION)..... 50

11.3 MEASUREMENT EQUIPMENT USED: ..... 50

11.4 MEASUREMENT RESULTS:..... 51

**12. ANTENNA APPLICATION ..... 53**

12.1 ANTENNA REQUIREMENT ..... 53

12.2 RESULT ..... 53

## 1. GENERAL INFORMATION

### 1.1 Product Description

The Electronica Clarion S.A. de C.V. , Model: CZ105BT (referred to as the EUT in this report) The EUT is an short range, lower power transmitter. It is designed by way of utilizing the following modulation achieves the system operating.

A major technical descriptions of EUT is described as following:

- A). Operation Frequency: 2402-2480MHz
- B). Modulation: GFSK,  $\pi/4$ -DQPSK, 8DPSK
- C). Number of Channel: 79
- D). Channel space: 1MHz
- E). Measure RF Output Power: 4.43dBm(0.002773W) (PK)
- F). Antenna Type: Inverted-E antenna
- G). Antenna Gain: 4dBi
- H). Power Supply: DC 10.8-15.6V
- I) Software Version: V00.04.3
- J)Hardware Version: 410-0CZ105AA-EC-00 VER1.0

The basic data rate of 1Mbps uses GFSK modulation and the enhanced data rate uses PSK modulation. For the enhanced data rate of 3Mbps 8DPSK modulation and of 2Mbps  $\pi/4$ -DQPSK modulation is used.

### 1.2 Related Submittal(s) / Grant (s)

This submittal(s) (test report) is intended for FCC ID: 2ABGY-CZ105BT filing to comply with Section 15.247 of the FCC Part 15, Subpart C Rules and FCC Public Notice DA 00-705.

### 1.3 Test Methodology

Both conducted and radiated testing were performed according to the procedures in ANSI C63.10 (2013). Radiated testing was performed at an antenna to EUT distance 3 meters.

### 1.4 Special Accessories

Not available for this EUT intended for grant.

### 1.5 Equipment Modifications

Not available for this EUT intended for grant.

## 1.6 Test Facility

### Site Description

EMC Lab. :

Registered on FCC, June 18, 2014  
The Certificate Number is 247565

Registered on Industry Canada, February 19, 2014  
The Certificate Number is 9444A.

Name of Firm : DONGGUAN EMTEK CO., LTD.

Site Location : No.281, Guantai Road, Nancheng District,  
Dongguan, Guangdong, China

## **2. System Test Configuration**

### **2.1 EUT Configuration**

The EUT configuration for testing is installed on RF field strength measurement to meet the Commissions requirement and operating in a manner which intends to maximize its emission characteristics in a continuous normal application.

### **2.2 EUT Exercise**

The Transmitter was operated in the normal operating mode. the Tx frequency was fixed which was for the purpose of the measurements.

### **2.3 Test Procedure**

#### **2.3.1 Conducted Emissions**

The EUT is a placed on as turn table which is 0.8 m above ground plane. According to the requirements in Section 13.1.4.1 of ANSI C63.10-2013. Conducted emissions from the EUT measured in the frequency range between 0.15 MHz and 30MHz using CISPR Quasi-Peak and average detector mode.

#### **2.3.2 Radiated Emissions**

Below 1000MHz, The EUT was placed on a turn table which is 0.8m above ground plane. And above 1000MHz, The EUT was placed on a styrofoam table which is 1.5m above ground plane. The turn table shall rotate 360 degrees to determine the position of maximum emission level. EUT is set 3m away from the receiving antenna which varied from 1m to 4m to find out the highest emission. And also, each emission was to be maximized by changing the polarization of receiving antenna both horizontal and vertical. In order to find out the max. emission, the relative positions of this transmitter(EUT) was rotated according to the requirements in Section 13.1.4.1 of ANSI C63.10-2013.



## 2.4 Configuration of Tested System

**Fig. 2-1 Configuration of Tested System**

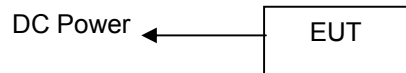

Table 2-1 Equipment Used in Tested System

Item	Equipment	Trade Mark	Model No.	FCC ID	Note
1.	CD/USB/SD/MP3/WMA DIGITAL MEDIA RECEVIER	Clarion	CZ105BT	2ABGY-CZ105BT	<b><i>EUT</i></b>

**Note:**

- (1) Unless otherwise denoted as EUT in 『Remark』 column , device(s) used in tested system is a support equipment.

### 3. Summary of Test Results

FCC Rules	Description Of Test	Result
§15.247(a)(1)	Channel Separation test	Compliant
§15.247(a)(1)	20dB Bandwidth	Compliant
§15.247(a)(1)(iii)	Quantity of Hopping Channel	Compliant
§15.247(a)(1)(iii)	Time of Occupancy(Dwell Time)	Compliant
§15.247(b)	Max Peak output Power test	Compliant
§15.247(d)	Band edge test	Compliant
§15.207	AC Power Conducted Emission	N/A
§15.247(d),§15.209	Radiated Emission	Compliant
§15.203	Antenna Requirement	Compliant
§1.1310	RF Exposure	Compliant

Remark: The EUT is supplied by Battery, there is no need for AC Power Conducted Emission test to be performed on this product.

### 4. Description of test modes

The EUT has been tested under TX operating condition.

This EUT is a FHSS system, were conducted to determine the final configuration from all possible combinations. We use software control the EUT, Let EUT hopping on and transmit with highest power, All the modes GFSK,  $\pi/4$ -DQPSK, 8DPSK have been tested. 79 Channels are provided by EUT. The 3 channels of lower, medium and higher were chosen for test.

Channel	Frequency(MHz)
1	2402
40	2441
79	2480

## 5. Radiated Emission Test

### 5.1 Measurement Procedure

1. The testing follows the guidelines in Spurious Radiated Emissions of ANSI C63.10-2013.
2. Below 1000MHz, The EUT was placed on a turn table which is 0.8m above ground plane. And above 1000MHz, The EUT was placed on a styrofoam table which is 1.5m above ground plane.
3. Maximum procedure was performed on the six highest emissions to ensure EUT compliance.
4. And also, each emission was to be maximized by changing the polarization of receiving antenna both horizontal and vertical.
5. Repeat above procedures until all frequency measured were complete.
6. For range 9KHz~30MHz, The measured value is really too low to be recorded.
7. For the radiated emission test above 1000MHz:  
Place the measurement antenna away from each area of the EUT determined to be a source of emissions at the specified measurement distance, while keeping the measurement antenna aimed at the source of emissions at each frequency of significant emissions, with polarization oriented for maximum response. The measurement antenna may have to be higher or lower than the EUT, depending on the radiation pattern of the emission and staying aimed at the emission source for receiving the maximum signal. The final measurement antenna elevation shall be that which maximizes the emissions. The measurement antenna elevation for maximum emissions shall be restricted to a range of heights of from 1 m to 4 m above the ground or reference ground plane.

When spectrum scanned from 30MHz to 1GHz setting resolution bandwidth 120KHz and video bandwidth 300KHz:

EMI Test Receiver	Setting
Attenuation	Auto
RB	120KHz
VB	300KHz
Detector	QP
Trace	Max hold

When spectrum scanned above 1GHz setting resolution bandwidth 1MHz, video bandwidth 3MHz:

EMI Test Receiver	Setting
Attenuation	Auto
RB	1MHz
VB	3MHz
Detector	Peak
Trace	Max hold

When spectrum scanned above 1GHz setting resolution bandwidth 1MHz, video bandwidth 10Hz:

EMI Test Receiver	Setting
Attenuation	Auto
RB	1MHz
VB	10Hz
Detector	Peak
Trace	Max hold

## 5.2 Test SET-UP (Block Diagram of Configuration)

(A) Radiated Emission Test Set-Up, Frequency Below 30MHz

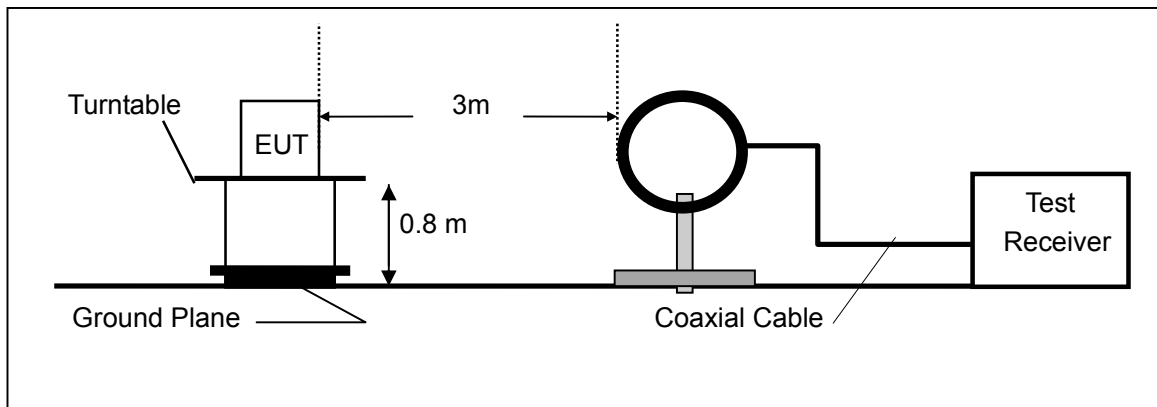

(B) Radiated Emission Test Set-Up, Frequency Below 1000MHz

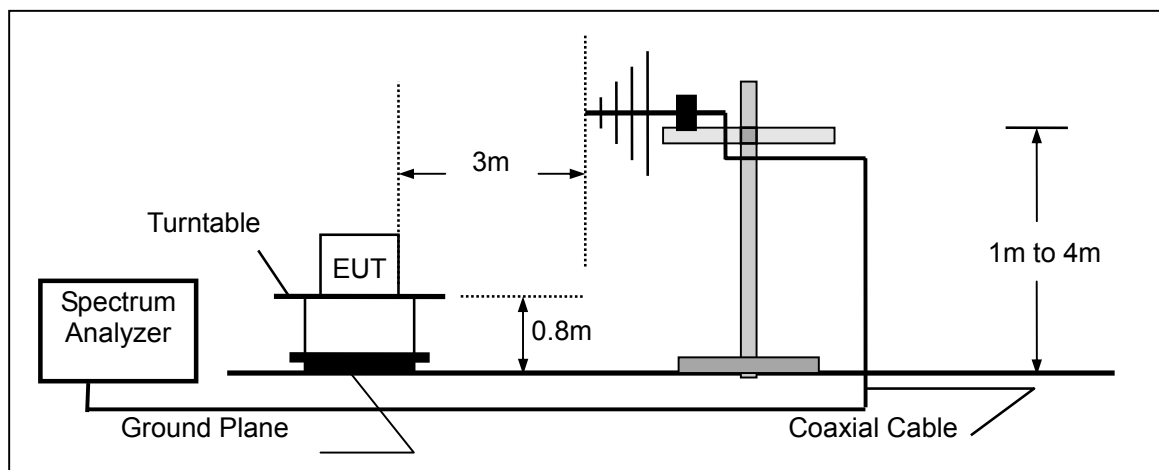

(C) Radiated Emission Test Set-Up, Frequency above 1000MHz

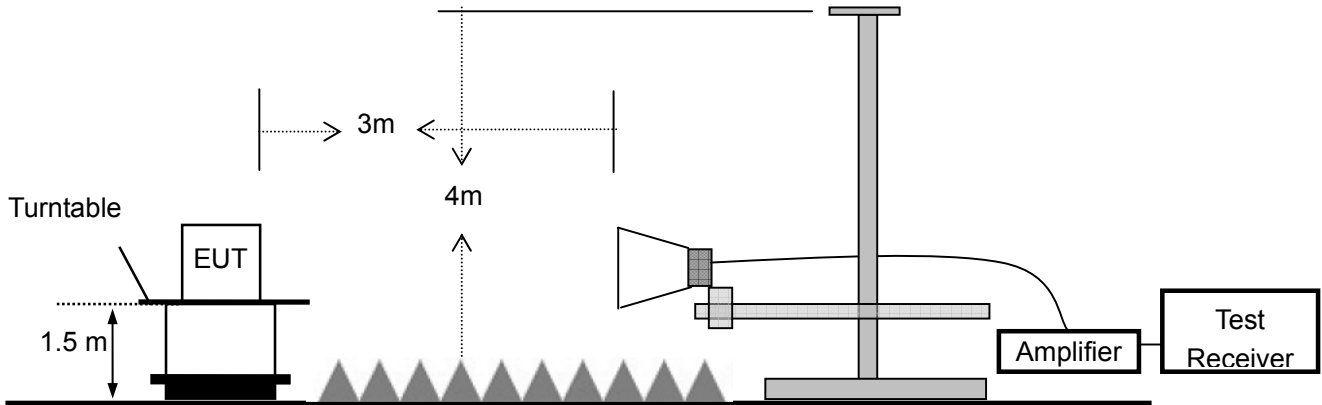

**5.3 Measurement Equipment Used:**

Item	Equipment	Manufacturer	Model No.	Serial No.	Characteristics	Last Cal.	Cal. Interval
1.	Test Receiver	Rohde & Schwarz	ESCI	1166.5950.0 3	9KHz-3GHz	3/15/2015	1 Year
2.	Loop Antenna	Schwarzbeck	FMZB 1519	012	9 KHz -30MHz	12/29/2014	1 Year
3.	Bilog Antenna	Schwarzbeck	VULB9163	000141	25MHz-2GHz	3/15/2015	1 Year
4.	Power Amplifier	CDS	RSU-M352	818	1MHz-1GHz	3/15/2015	1 Year
5.	Power Amplifier	HP	8447F	OPT H64	1GHz-26.5GHz	3/15/2015	1 Year
6.	Color Monitor	SUNSPO	SP-140A	N/A	--	3/15/2015	1 Year
7.	Single Line Filter	JIANLI	XL-3	N/A	--	3/15/2015	1 Year
8.	Single Phase Power Line Filter	JIANLI	DL-2X100B	N/A	--	3/15/2015	1 Year
9.	3 Phase Power Line Filter	JIANLI	DL-4X100B	N/A	--	3/15/2015	1 Year
10.	DC Power Filter	JIANLI	DL-2X50B	N/A	--	3/15/2015	1 Year
11.	Cable	Schwarzbeck	PLF-100	549489	9KHz-3GHz	3/15/2015	1 Year
12.	Cable	Rosenberger	CIL02	A0783566	9KHz-3GHz	3/15/2015	1 Year
13.	Cable	Rosenberger	RG 233/U	525178	9KHz-3GHz	3/15/2015	1 Year
14.	Signal Analyzer	Rohde & Schwarz	FSV30	103040	9KHz-40GHz	12/29/2014	1 Year
15.	Horn Antenna	Schwarzbeck	BBHA9120D	9120D-1272	1GHz-18GHz	12/29/2014	1 Year
16.	Horn Antenna	Schwarzbeck	BBHA 9170	BBHA91703 99	14GHz -26.5GHz	12/29/2014	1 Year
17.	Power Amplifier	LUNAR EM	LNA1G18-4 0	J101000000 81	1GHz-26.5GHz	12/29/2014	1 Year
18.	Cable	H+S	CBL-26	N/A	1GHz-26.5GHz	12/29/2014	1 Year
19.	Cable	H+S	CBL-26	N/A	1GHz-26.5GHz	12/29/2014	1 Year
20.	Cable	H+S	CBL-26	N/A	1GHz-26.5GHz	12/29/2014	1 Year

### 5.4 Measurement Result

All the modulation modes were tested the data of the test mode are recorded in the following pages.

#### Below 30MHz:

Operation Mode: TX Mode                      Test Date : July 13, 2015  
 Frequency Range: 9KHz~30MHz              Temperature : 28°C  
 Test Result: PASS                              Humidity : 60 %  
 Measured Distance: 3m                        Test By: Andy

Freq. (MHz)	Ant.Pol. H/V	Emission Level (dBuV/m)	Limit 3m (dBuV/m)	Over (dB)
--	--	--	--	--

Note: the amplitude of spurious emission that is attenuated by more than 20dB below the permissible limit has no need to be reported.

Distance extrapolation factor =  $40 \log(\text{Specific distance} / \text{test distance})$  (dB);

Limit line = Specific limits (dBuV) + distance extrapolation factor.

#### Below 1000MHz:

Pass.

All the modulation modes were tested the data of the worst mode (TX 2402MHz) are recorded in the following pages and the others modulation methods do not exceed the limits.

Please refer to the following data.

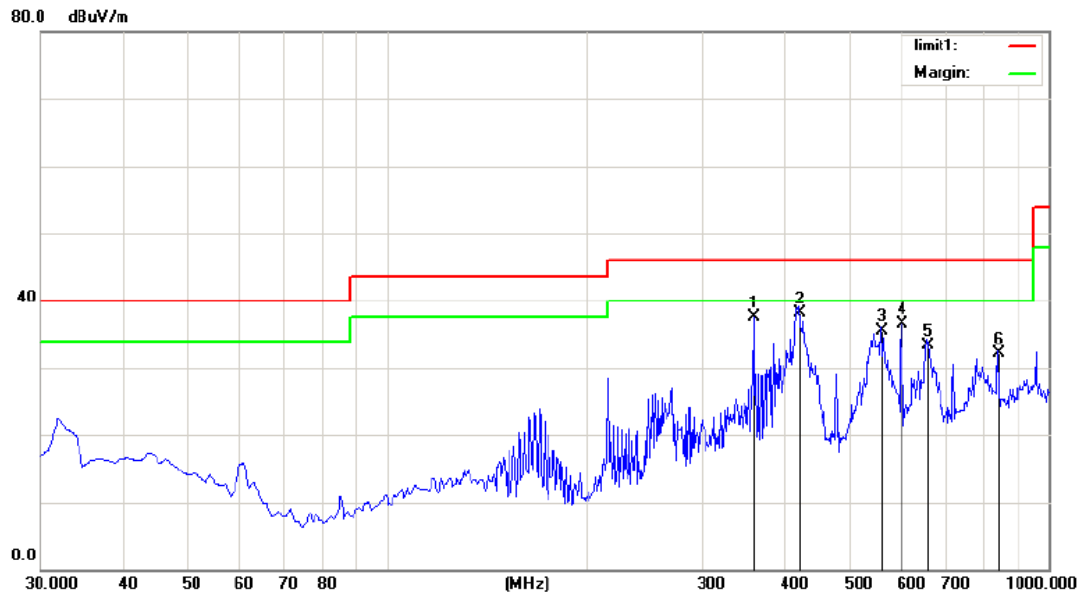

Site site #1      Polarization: **Horizontal**      Temperature: 26  
 Limit: (RE)FCC PART 15 class B 3m      Power: DC 12V      Humidity: 55 %  
 Mode:TX 2402(GFSK)  
 Note:

No.	Mk.	Freq.	Reading Level	Correct Factor	Measurement	Limit	Over	Antenna Height	Table Degree
		MHz	dBuV	dB	dBuV/m	dBuV/m	dB	cm	degree
1		359.8000	50.15	-12.71	37.44	46.00	-8.56	QP	0
2	*	421.8800	49.54	-11.38	38.16	46.00	-7.84	QP	0
3		560.5900	44.43	-8.87	35.56	46.00	-10.44	QP	0
4		599.3900	44.92	-8.41	36.51	46.00	-9.49	QP	0
5		655.6500	41.24	-7.86	33.38	46.00	-12.62	QP	0
6		839.9500	36.63	-4.56	32.07	46.00	-13.93	QP	0

\*:Maximum data    x:Over limit    !:over margin

Operator: QIU

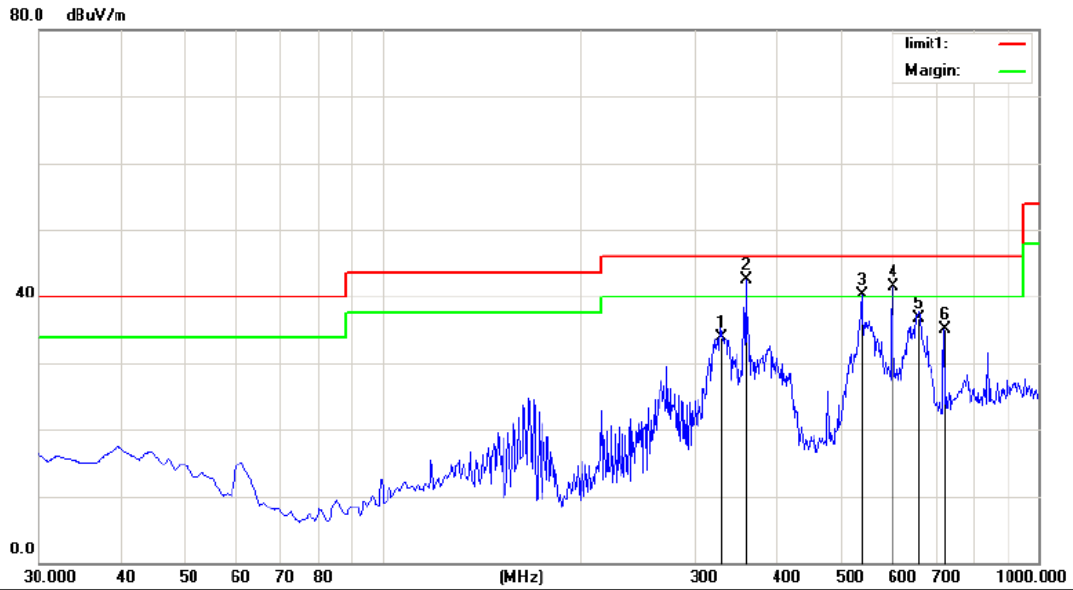

Site site #1  
 Limit: (RE)FCC PART 15 class B 3m  
 Mode:TX 2402(GFSK)  
 Note:

Polarization: **Vertical**  
 Power: DC 12V

Temperature: 26  
 Humidity: 55 %

No.	Mk.	Freq.	Reading Level	Correct Factor	Measurement	Limit	Over	Antenna Height	Table Degree	Comment
		MHz	dBuV	dB	dBuV/m	dBuV/m	dB	cm	degree	
1		328.7600	47.06	-13.22	33.84	46.00	-12.16	QP	0	
2	*	359.8000	55.20	-12.71	42.49	46.00	-3.51	QP	0	
3	!	541.1900	49.94	-9.59	40.35	46.00	-5.65	QP	0	
4	!	599.3900	49.90	-8.41	41.49	46.00	-4.51	QP	0	
5		656.6200	44.68	-7.92	36.76	46.00	-9.24	QP	0	
6		719.6700	41.75	-6.65	35.10	46.00	-10.90	QP	0	

\*:Maximum data    x:Over limit    !:over margin

Operator: QIU



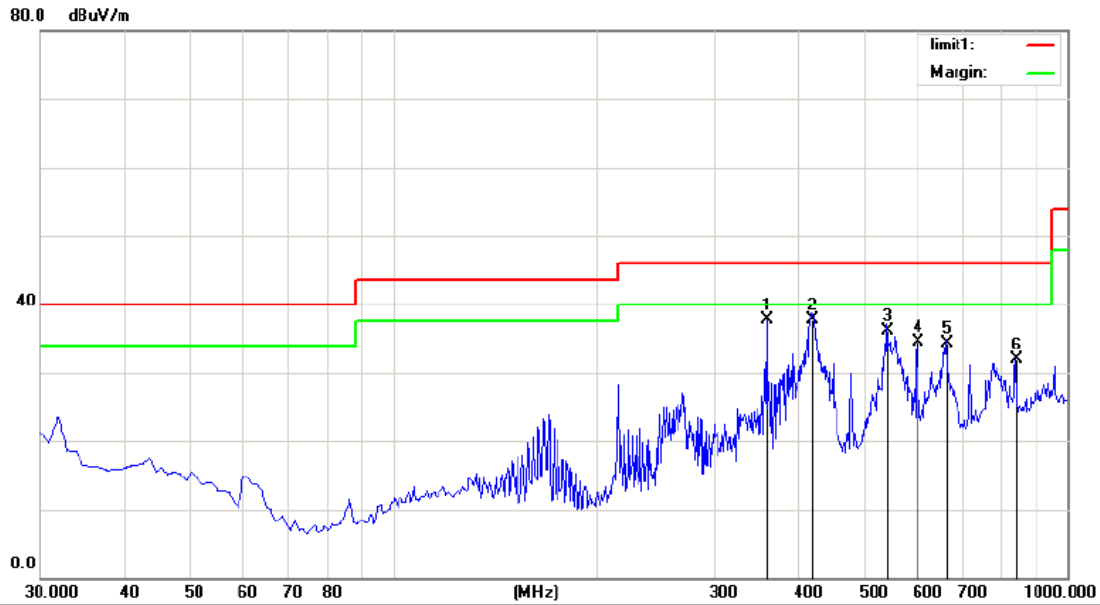

Site site #1 Polarization: **Horizontal** Temperature: 26  
 Limit: (RE)FCC PART 15 class B 3m Power: DC 12V Humidity: 55 %  
 Mode:TX 2402(Pi/4-DQPSK)  
 Note:

No.	Mk.	Freq.	Reading Level	Correct Factor	Measurement	Limit	Over	Antenna Height	Table Degree
		MHz	dBuV	dB	dBuV/m	dBuV/m	dB	cm	degree
1	*	359.8000	50.48	-12.71	37.77	46.00	-8.23	QP	0
2		418.9700	49.09	-11.37	37.72	46.00	-8.28	QP	0
3		543.1300	45.24	-9.21	36.03	46.00	-9.97	QP	0
4		599.3900	42.93	-8.41	34.52	46.00	-11.48	QP	0
5		661.4700	42.13	-7.79	34.34	46.00	-11.66	QP	0
6		839.9500	36.56	-4.56	32.00	46.00	-14.00	QP	0

\*:Maximum data x:Over limit l:over margin

Operator: QIU

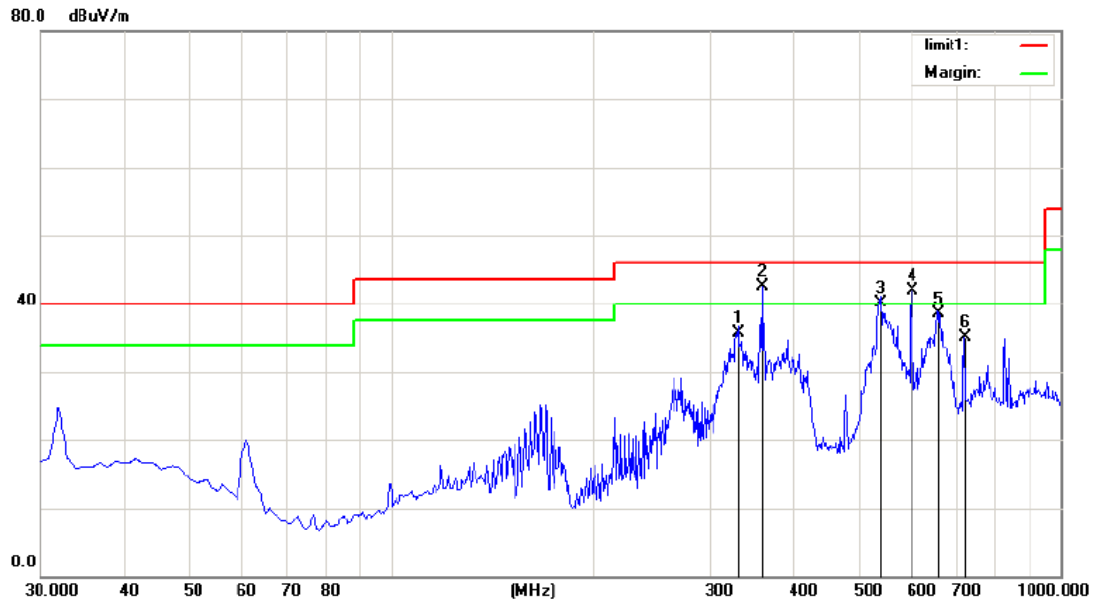

Site site #1 Polarization: *Vertical* Temperature: 26  
 Limit: (RE)FCC PART 15 class B 3m Power: DC 12V Humidity: 55 %  
 Mode: TX 2402(Pi/4-DQPSK)  
 Note:

No.	Mk.	Freq.	Reading Level	Correct Factor	Measurement	Limit	Over	Antenna Height	Table Degree	
		MHz	dBuV	dB	dBuV/m	dBuV/m	dB	cm	degree	Comment
1		330.7000	48.99	-13.21	35.78	46.00	-10.22	QP	0	
2	*	359.8000	55.21	-12.71	42.50	46.00	-3.50	QP	0	
3	!	540.2200	49.68	-9.62	40.06	46.00	-5.94	QP	0	
4	!	599.3900	50.30	-8.41	41.89	46.00	-4.11	QP	0	
5		655.6500	46.41	-7.92	38.49	46.00	-7.51	QP	0	
6		719.6700	41.76	-6.65	35.11	46.00	-10.89	QP	0	

\*:Maximum data x:Over limit !:over margin

Operator: QIU

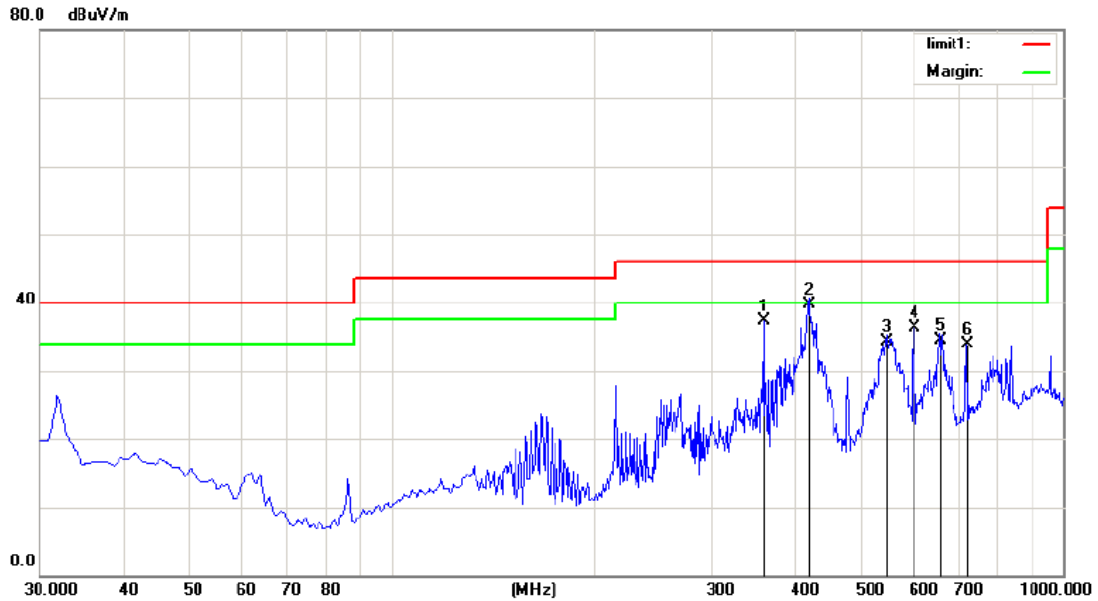

Site site #1      Polarization: **Horizontal**      Temperature: 26  
 Limit: (RE)FCC PART 15 class B 3m      Power: DC 12V      Humidity: 55 %  
 Mode: TX 2402(8DPSK)  
 Note:

No.	Mk.	Freq. MHz	Reading Level dBuV	Correct Factor dB	Measure- ment dBuV/m	Limit dBuV/m	Over dB	Antenna Height cm	Table Degree	Comment
1		359.8000	50.01	-12.71	37.30	46.00	-8.70	QP	0	
2	*	419.9400	51.14	-11.39	39.75	46.00	-6.25	QP	0	
3		548.9500	43.23	-9.01	34.22	46.00	-11.78	QP	0	
4		599.3900	44.65	-8.41	36.24	46.00	-9.76	QP	0	
5		655.6500	42.27	-7.86	34.41	46.00	-11.59	QP	0	
6		719.6700	40.57	-6.65	33.92	46.00	-12.08	QP	0	

\*:Maximum data    x:Over limit    !:over margin

Operator: QIU

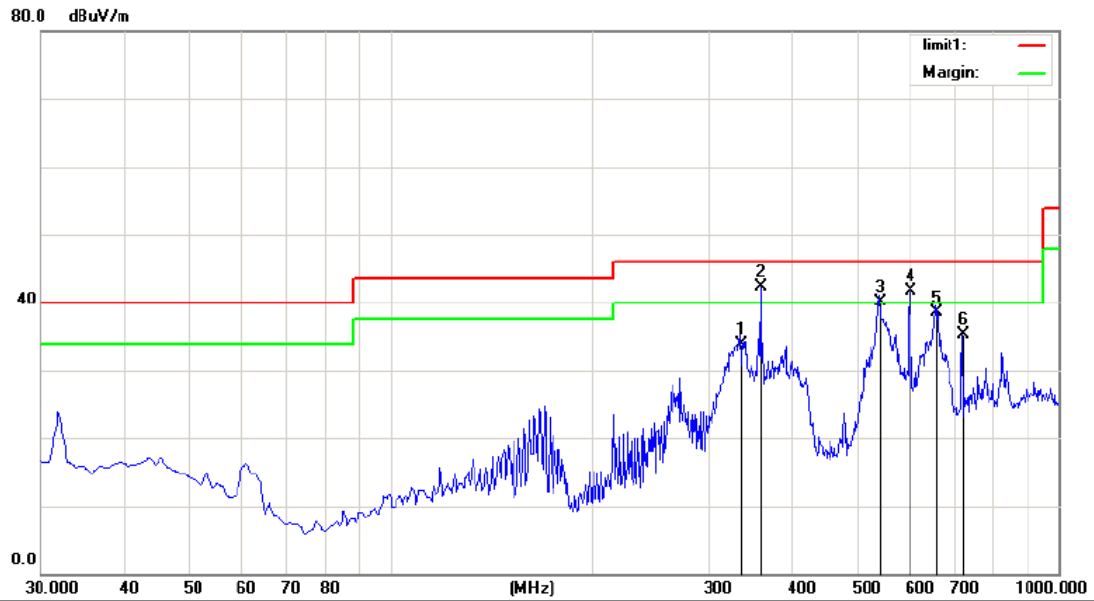

Site site #1      Polarization: **Vertical**      Temperature: 26  
 Limit: (RE)FCC PART 15 class B 3m      Power: DC 12V      Humidity: 55 %  
 Mode: TX 2402(8DPSK)  
 Note:

No.	Mk.	Freq.	Reading Level	Correct Factor	Measurement	Limit	Over	Antenna Height	Table Degree	
		MHz	dBuV	dB	dBuV/m	dBuV/m	dB	cm	degree	Comment
1		334.5800	47.09	-13.20	33.89	46.00	-12.11		0	
2	*	359.8000	55.05	-12.71	42.34	46.00	-3.66		0	
3	!	542.1600	49.64	-9.57	40.07	46.00	-5.93		0	
4	!	599.3900	50.21	-8.41	41.80	46.00	-4.20		0	
5		655.6500	46.48	-7.92	38.56	46.00	-7.44		0	
6		719.6700	41.94	-6.65	35.29	46.00	-10.71		0	

\*:Maximum data    x:Over limit    !:over margin

Operator: QIU

**Above 1000MHz~10<sup>th</sup> Harmonics:**

Operation Mode: TX Mode (CH1: 2402MHz) Test Date : July 13, 2015

Freq. (MHz)	Ant. Pol. H/V	Emission Level(dBuV/m)		Limit 3m(dBuV/m)		Over(dB)	
		PK	AV	PK	AV	PK	AV
4804	V	64.05	44.02	74	54	-9.95	-9.98
7206	V	63.18	43.31	74	54	-10.82	-10.69
9608	V	62.07	42.82	74	54	-11.93	-11.18
12010	V	61.73	40.92	74	54	-12.27	-13.08
14412	V	60.38	38.49	74	54	-13.62	-15.51
16814	V	58.79	37.14	74	54	-15.21	-16.86
4804	H	65.08	46.28	74	54	-8.92	-7.72
7206	H	64.34	45.31	74	54	-9.66	-8.69
9608	H	63.72	44.08	74	54	-10.28	-9.92
12010	H	62.05	43.18	74	54	-11.95	-10.82
14412	H	61.92	42.92	74	54	-12.08	-11.08
16814	H	58.49	40.34	74	54	-15.51	-13.66

Operation Mode: TX Mode (CH40: 2441MHz) Test Date : July 13, 2015

Freq. (MHz)	Ant. Pol. H/V	Emission Level(dBuV/m)		Limit 3m(dBuV/m)		Over(dB)	
		PK	AV	PK	AV	PK	AV
4882	V	64.32	44.05	74	54	-9.68	-9.95
7323	V	63.15	42.18	74	54	-10.85	-11.82
9764	V	62.82	40.23	74	54	-11.18	-13.77
12205	V	60.72	38.49	74	54	-13.28	-15.51
14646	V	58.49	37.12	74	54	-15.51	-16.88
17087	V	57.12	36.05	74	54	-16.88	-17.95
4882	H	65.33	45.28	74	54	-8.67	-8.72
7323	H	64.08	44.13	74	54	-9.92	-9.87
9764	H	63.82	43.38	74	54	-10.18	-10.62
12205	H	61.72	42.01	74	54	-12.28	-11.99
14646	H	60.59	41.82	74	54	-13.41	-12.18
17087	H	57.19	38.75	74	54	-16.81	-15.25

Operation Mode: TX Mode (CH79: 2480MHz) Test Date : July 13, 2015

Freq. (MHz)	Ant. Pol. H/V	Emission Level(dBuV/m)		Limit 3m(dBuV/m)		Over(dB)	
		PK	AV	PK	AV	PK	AV
4960	V	64.32	45.32	74	54	-9.68	-8.68
7440	V	63.08	44.18	74	54	-10.92	-9.82
9920	V	62.17	43.07	74	54	-11.83	-10.93
12400	V	61.34	42.92	74	54	-12.66	-11.08
14880	V	60.25	41.02	74	54	-13.75	-12.98
17360	V	58.47	40.33	74	54	-15.53	-13.67
4960	H	65.38	46.38	74	54	-8.62	-7.62
7440	H	64.21	44.17	74	54	-9.79	-9.83
9920	H	63.03	43.32	74	54	-10.97	-10.68
12400	H	62.82	42.02	74	54	-11.18	-11.98
14880	H	60.37	40.38	74	54	-13.63	-13.62
17360	H	58.45	38.75	74	54	-15.55	-15.25

**Other harmonics emissions are lower than 20dB below the allowable limit.**

- Note:**
- (1) All Readings are Peak Value and AV.
  - (2) Emission Level= Reading Level+ Probe Factor +Cable Loss.
  - (3) The average measurement was not performed when the peak measured data under the limit of average detection.
  - (4) The results of worst case(GFSK) was recorded.

**5.5 Radiated Measurement Photos:**



## 6. Channel Separation test

### 6.1 Measurement Procedure

The EUT was operating in hopping mode or could be controlled its channel. Printed out the test result from the spectrum by hard copy function.

### 6.2 Test SET-UP (Block Diagram of Configuration)

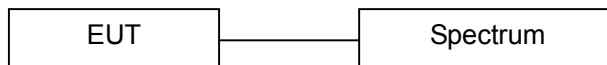

### 6.3 Measurement Equipment Used:

EQUIPMENT TYPE	MFR	MODEL NUMBER	SERIAL NUMBER	LAST CAL.	CAL DUE.
Spectrum Analyzer	Rohde & Schwarz	FSV30	1321.3008K	05/16/2015	05/15/2016
Coaxial Cable	CDS	79254	46107086	05/16/2015	05/15/2016
Antenna Connector	ARTHUR-YANG	2244-N1TG1	N/A	05/16/2015	05/15/2016

Remark: The temporary antenna connector is soldered on the PCB board in order to perform conducted tests and this temporary antenna connector is listed in the equipment list.

### 6.4 Measurement Results:

Refer to attached data chart.

Spectrum Detector:	PK	Test Date :	July 13, 2015
Test By:	Andy	Temperature :	24°C
Test Result:	PASS	Humidity :	53 %
Modulation:	GFSK		

Channel number	Channel frequency (MHz)	Separation Read Value (kHz)	Separation Limit 20dB Down BW(kHz)
1	2402	1001	>815
40	2441	1001	>818
79	2480	1001	>818



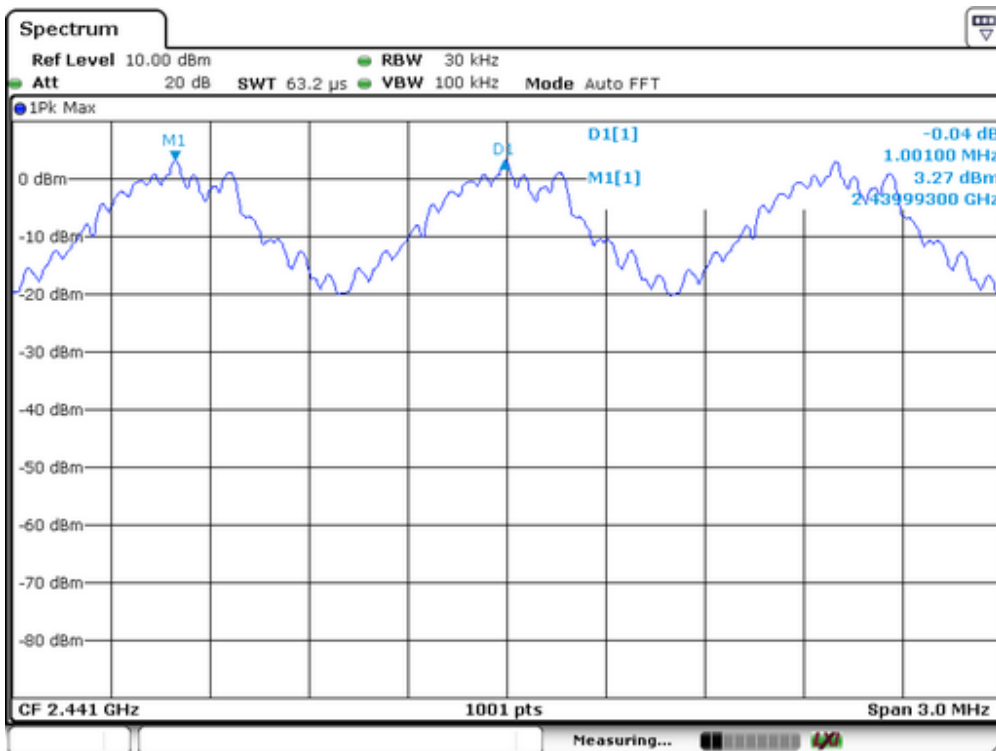
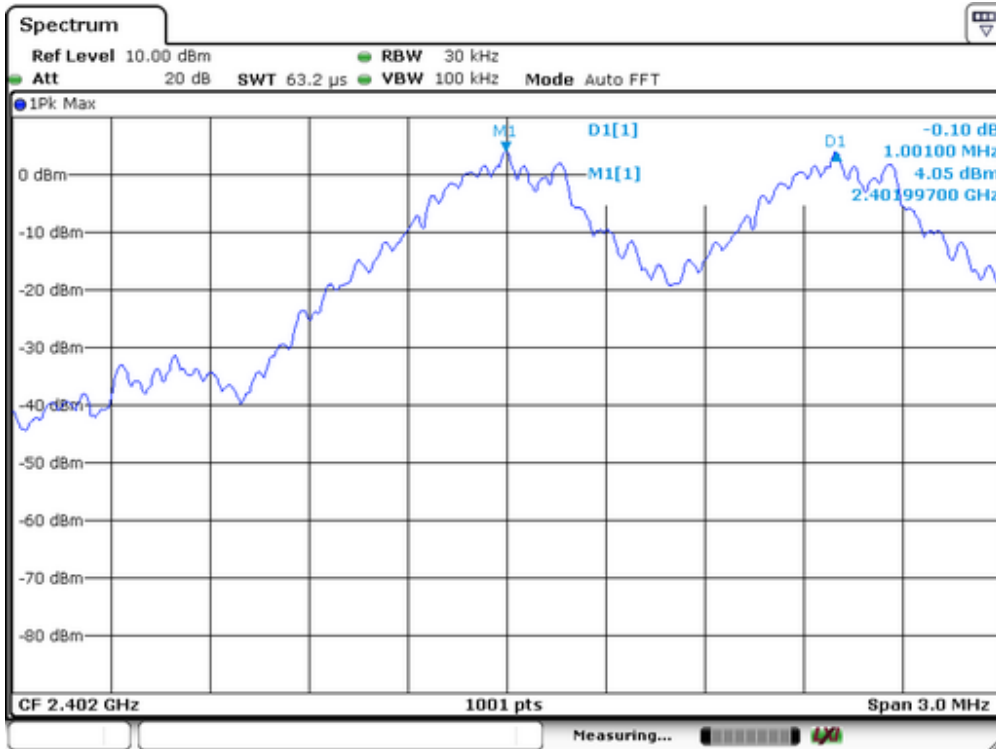

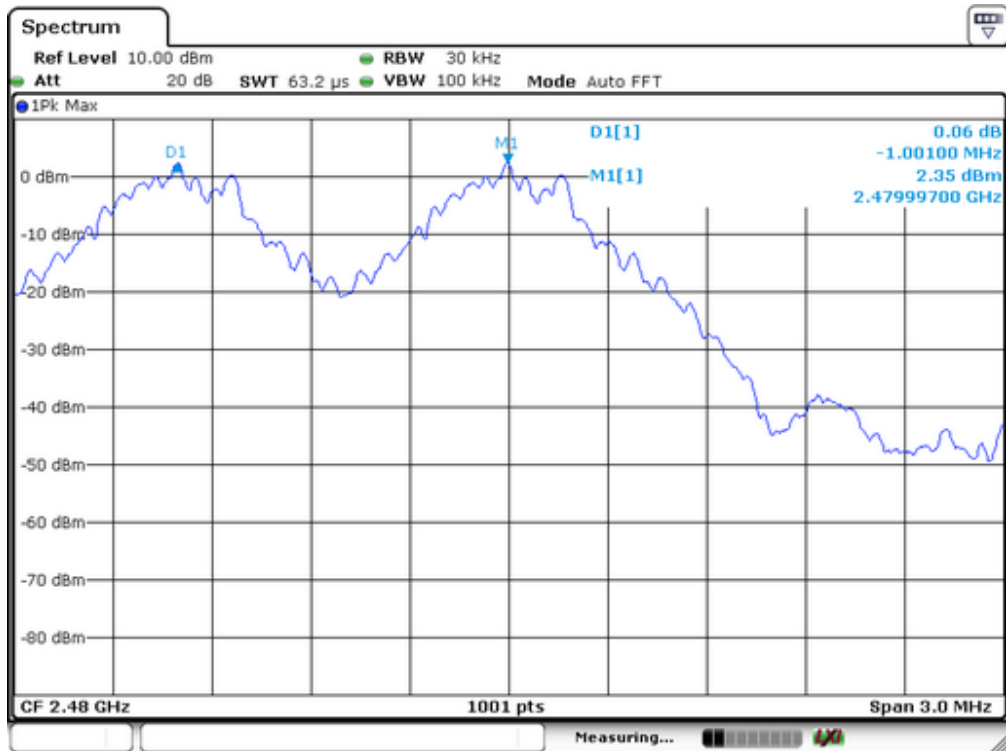

Spectrum Detector: PK Test Date : July 13, 2015  
 Test By: Andy Temperature : 24°C  
 Test Result: PASS Humidity : 53 %  
 Modulation: 1/4 $\pi$ -DQPSK

Channel number	Channel frequency (MHz)	Separation Read Value (kHz)	Separation Limit 2/3 20dB Down BW(kHz)
1	2402	1001	>824
40	2441	1001	>824
79	2480	1001	>828

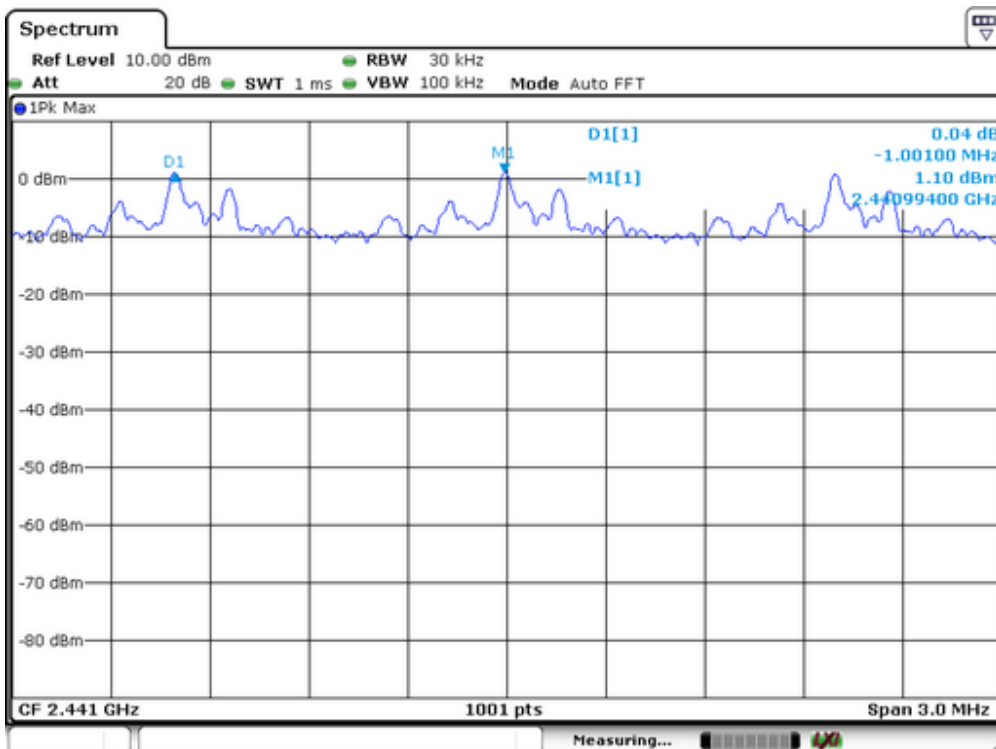
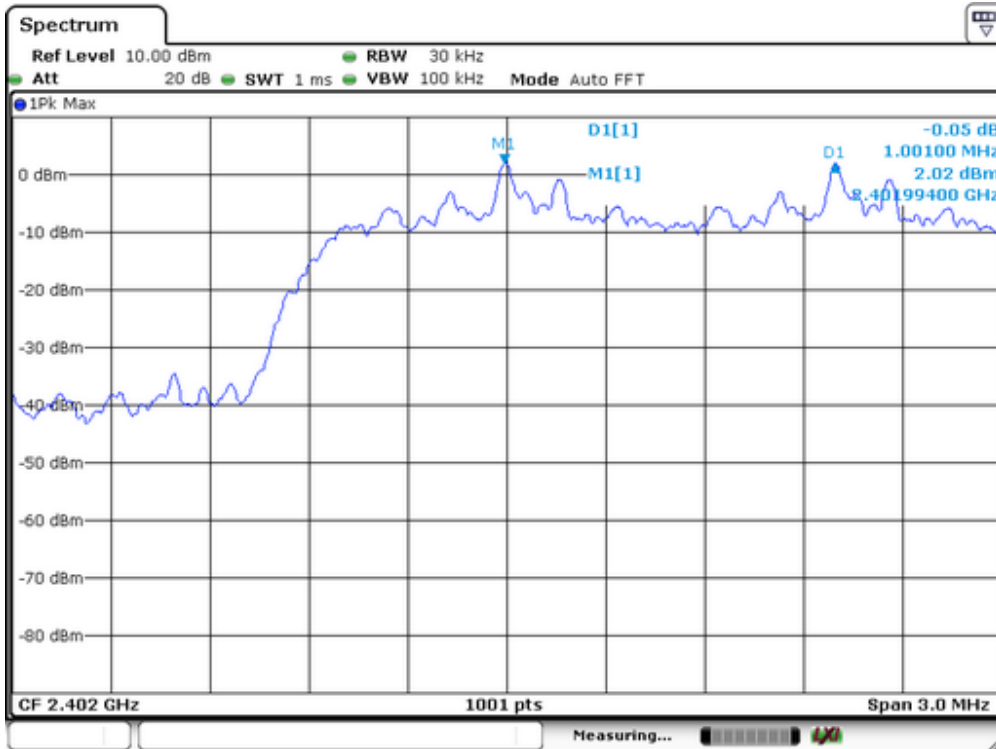

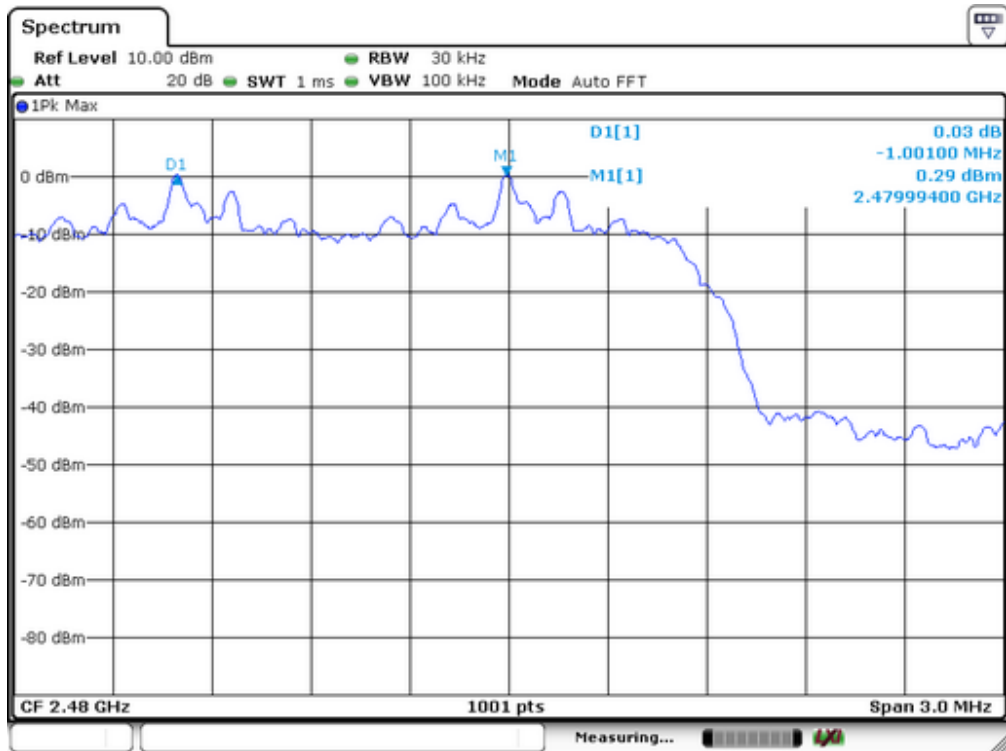

Spectrum Detector:	PK	Test Date :	July 13, 2015
Test By:	Andy	Temperature :	24 °C
Test Result:	PASS	Humidity :	53 %
Modulation:	8DPSK		

Channel number	Channel frequency (MHz)	Separation Read Value (kHz)	Separation Limit 2/3 20dB Down BW(kHz)
1	2402	1001	>808
40	2441	1001	>806
79	2480	1001	>806

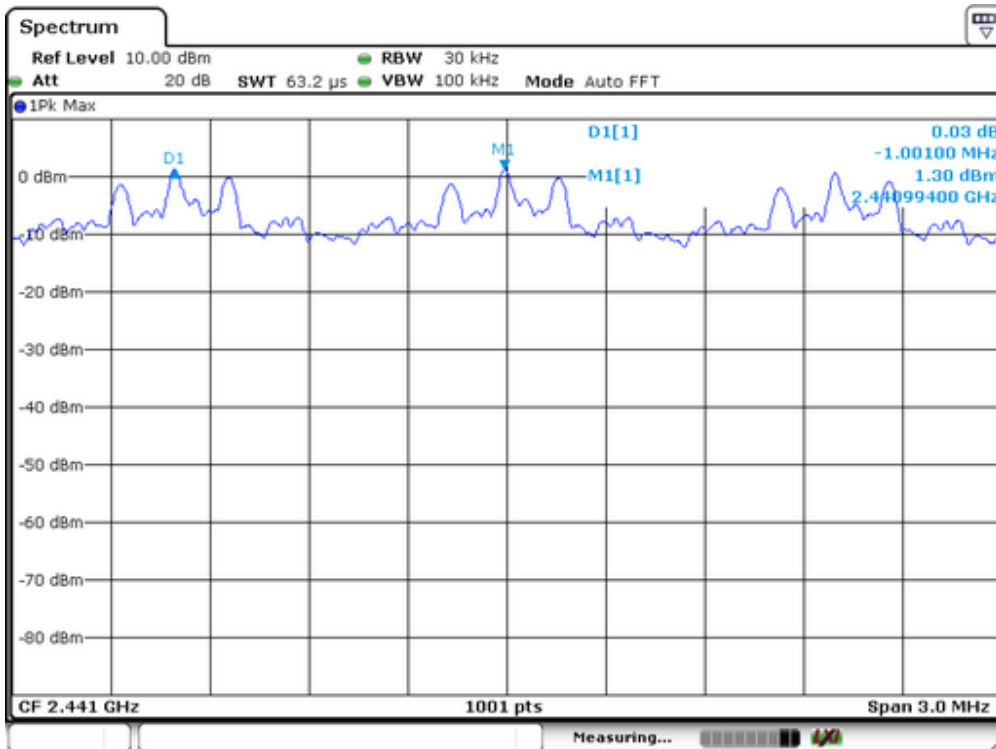
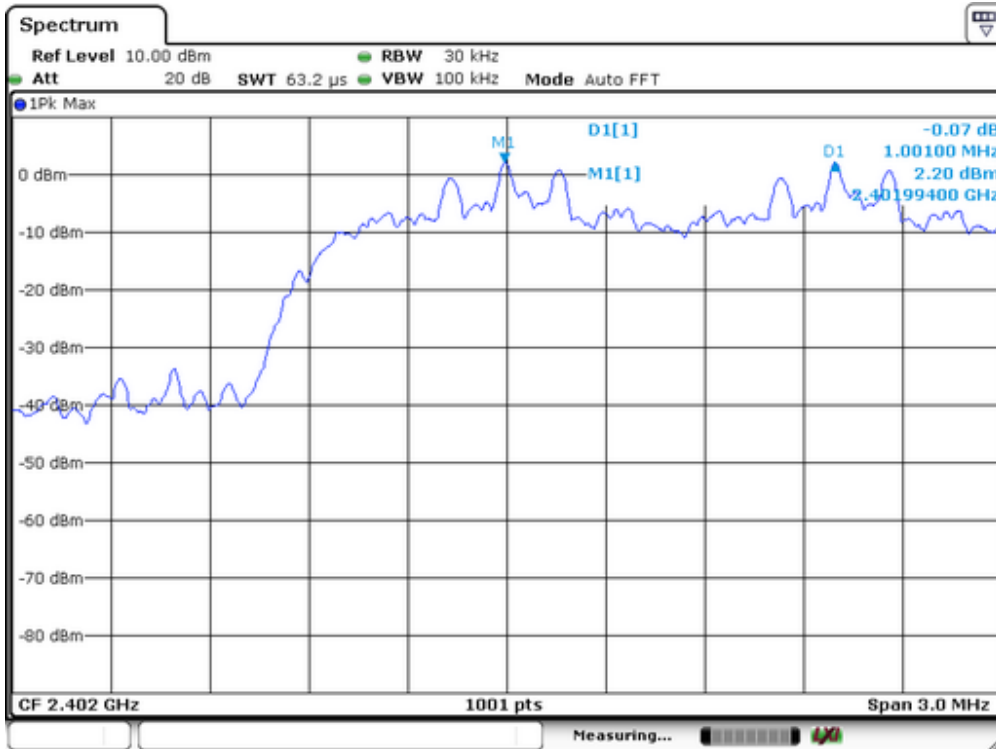

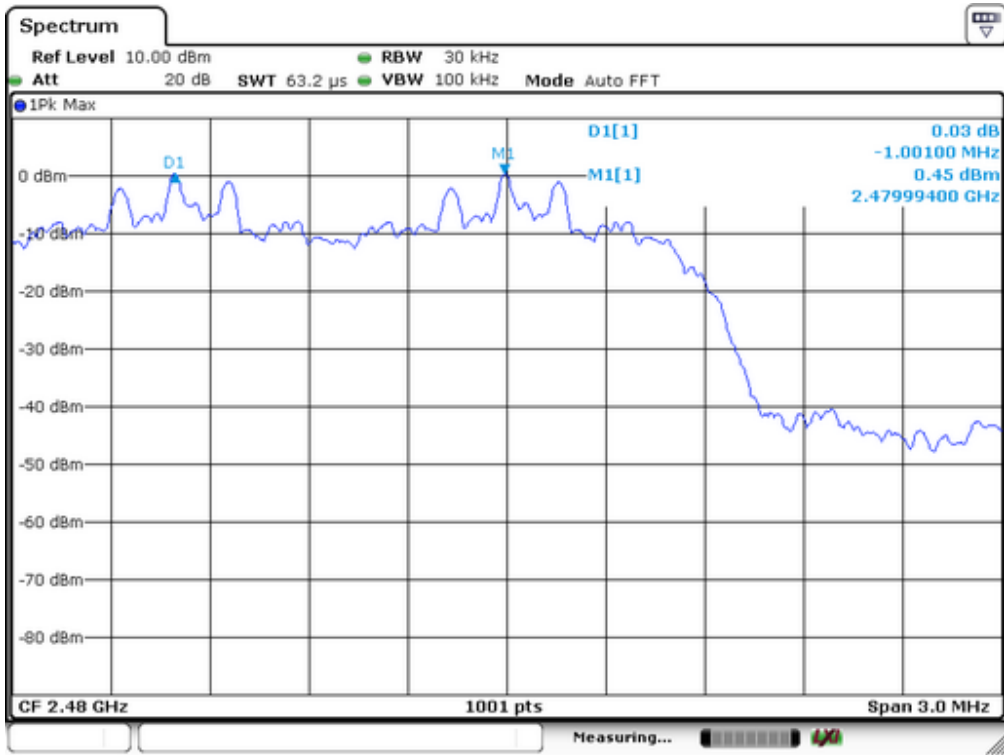

## 7. 20dB Bandwidth test

### 7.1 Measurement Procedure

The EUT was operating in hopping mode or could be controlled its channel. Printed out the test result from the spectrum by hard copy function.

### 7.2 Test SET-UP (Block Diagram of Configuration)



### 7.3 Measurement Equipment Used:

EQUIPMENT TYPE	MFR	MODEL NUMBER	SERIAL NUMBER	LAST CAL.	CAL DUE.
Spectrum Analyzer	Rohde & Schwarz	FSV30	1321.3008K	05/16/2015	05/15/2016
Coaxial Cable	CDS	79254	46107086	05/16/2015	05/15/2016
Antenna Connector	ARTHUR-YANG	2244-N1TG1	N/A	05/16/2015	05/15/2016

Remark: The temporary antenna connector is soldered on the PCB board in order to perform conducted tests and this temporary antenna connector is listed in the equipment list.

### 7.4 Measurement Results:

Refer to attached data chart.

Spectrum Detector:	PK	Test Date :	July 13, 2015
Test By:	Andy	Temperature :	25 °C
Test Result:	PASS	Humidity :	50 %
Modulation:	GFSK		

Channel number	Channel frequency (MHz)	20dB Down BW(KHz)
1	2402	815
40	2441	818
79	2480	818

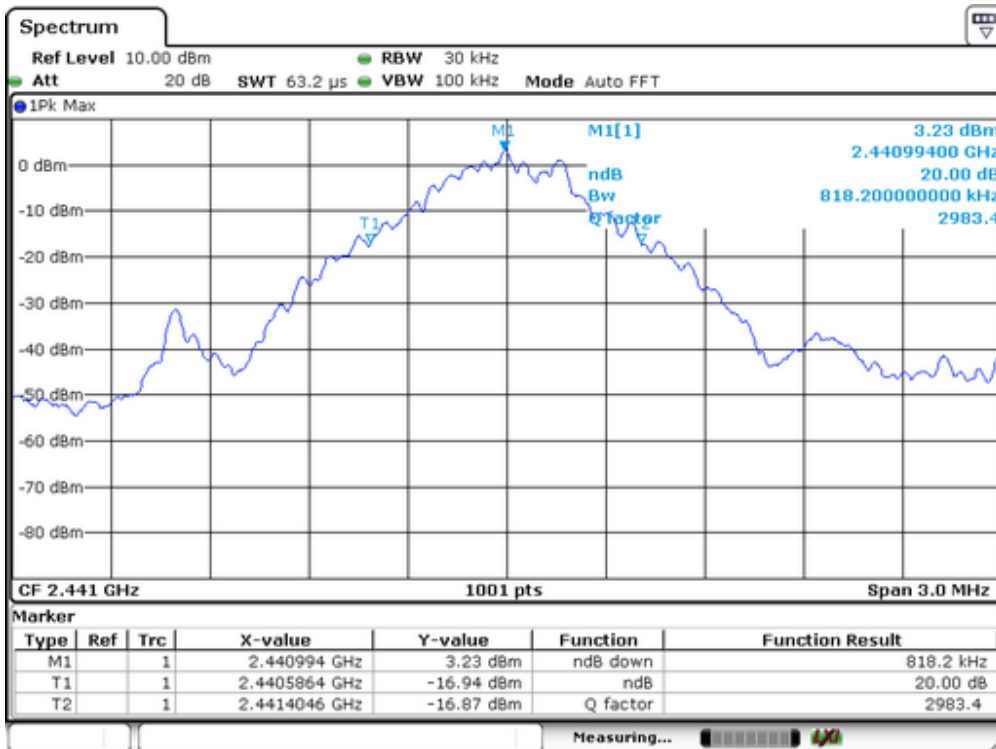
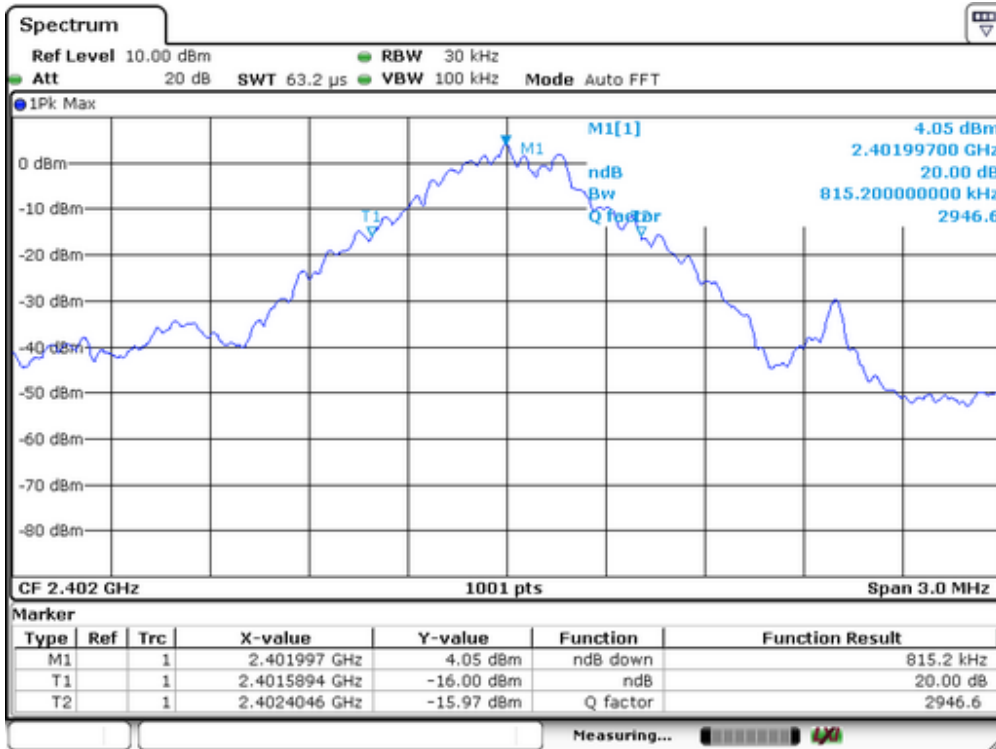



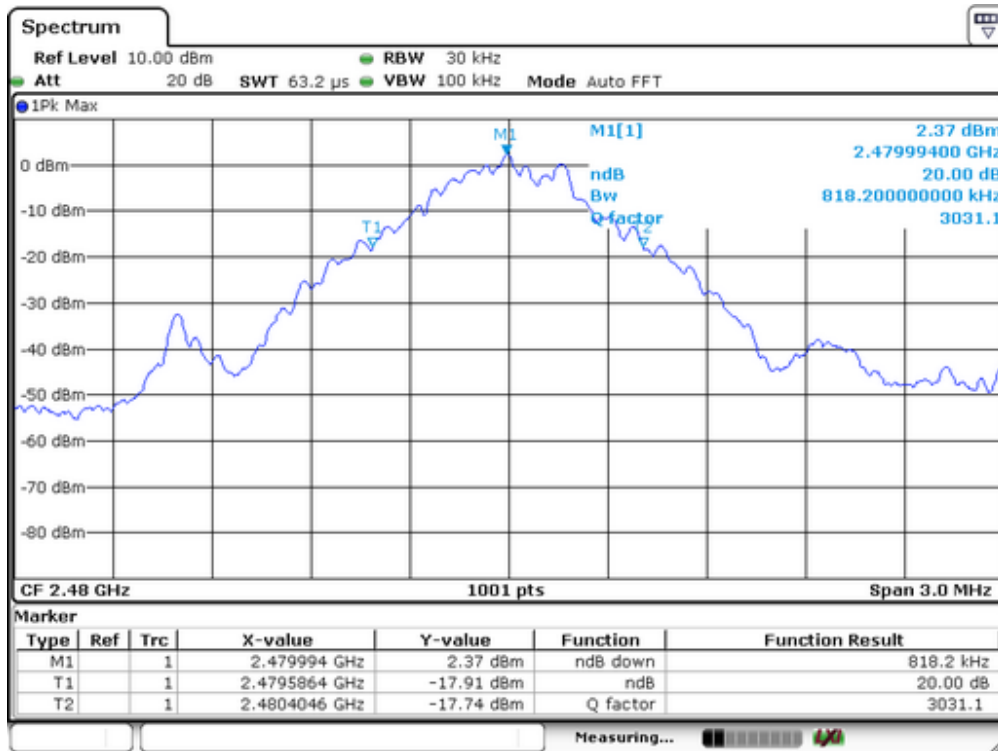

Spectrum Detector: PK                      Test Date : July 13, 2015  
 Test By: Andy                                  Temperature : 24°C  
 Test Result: PASS                              Humidity : 53 %  
 Modulation:  $\pi/4$ -DQPSK

Channel number	Channel frequency (MHz)	20dB Down BW(kHz)
1	2402	1237
40	2441	1237
79	2480	1243

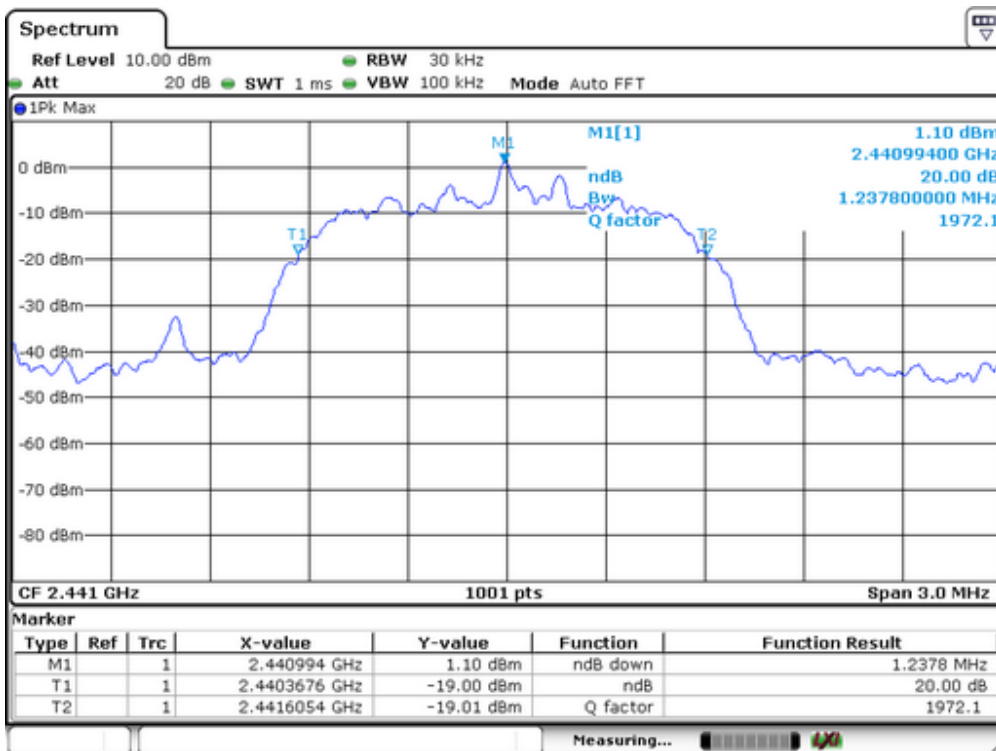
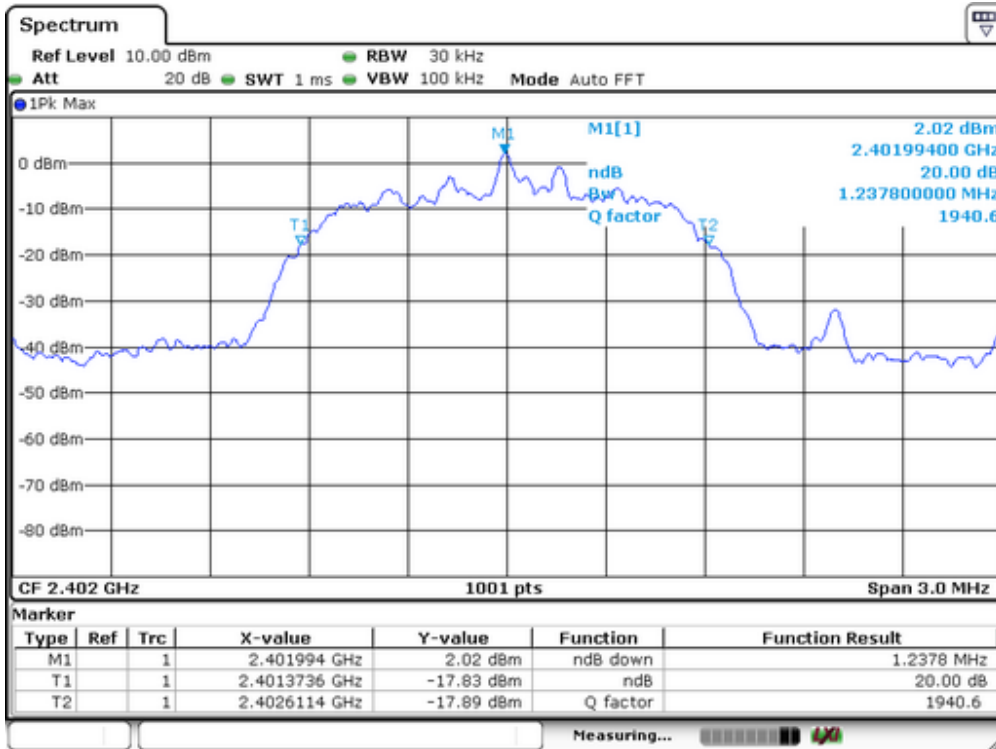

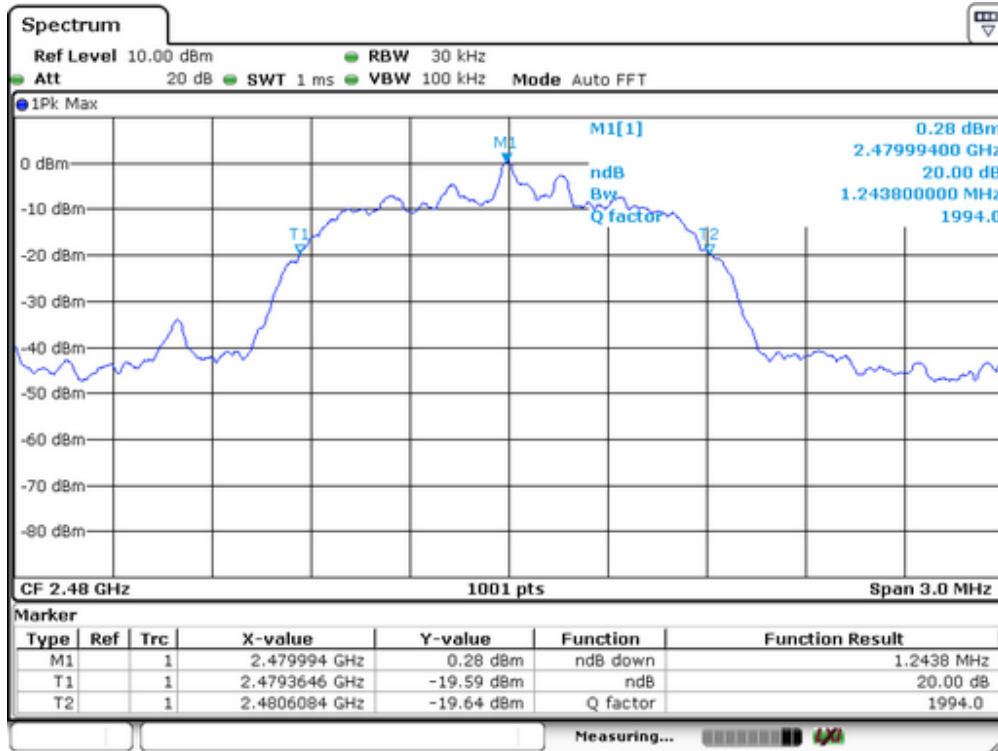

Spectrum Detector:	PK	Test Date :	July 13, 2015
Test By:	Andy	Temperature :	24°C
Test Result:	PASS	Humidity :	53 %
Modulation:	8DPSK		

Channel number	Channel frequency (MHz)	20dB Down BW(kHz)
1	2402	1213
40	2441	1210
79	2480	1210

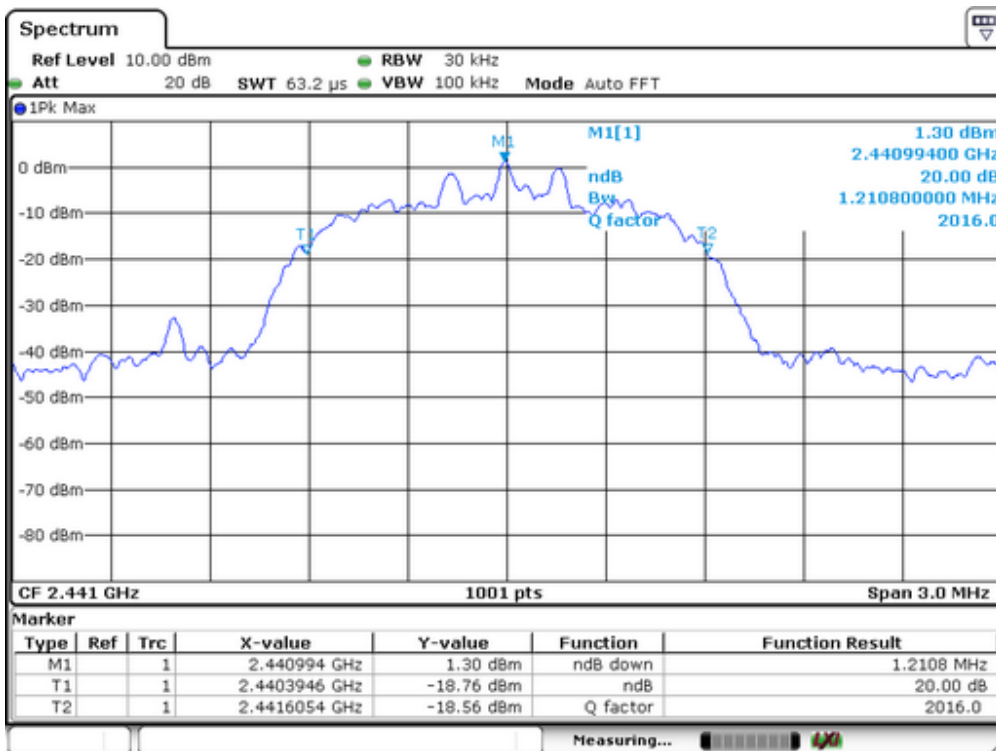
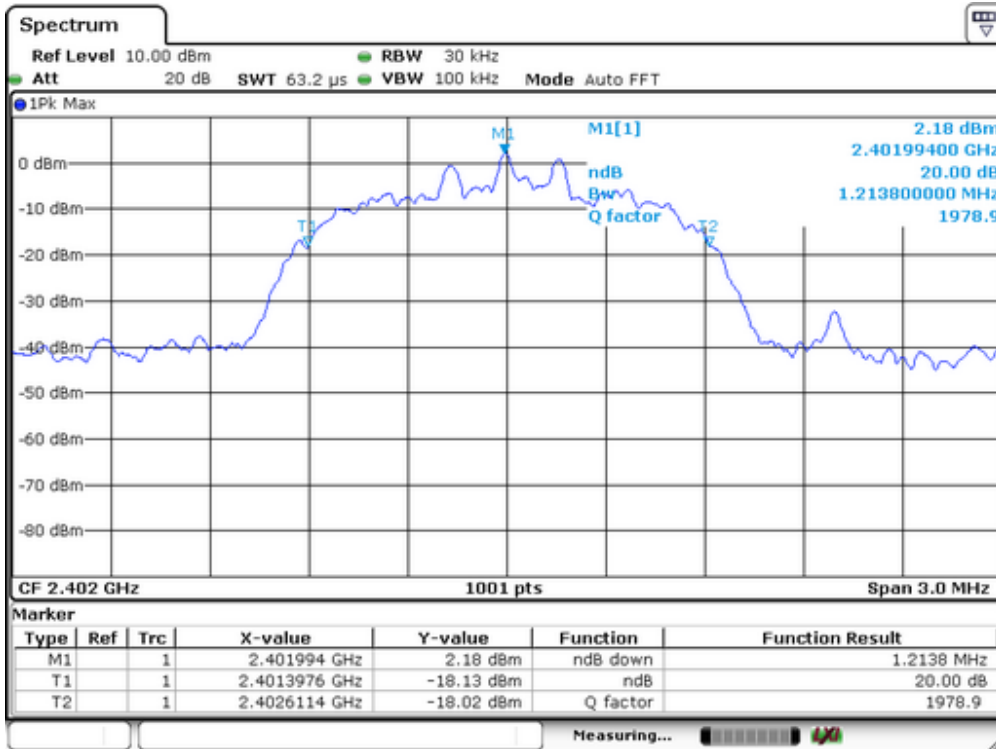

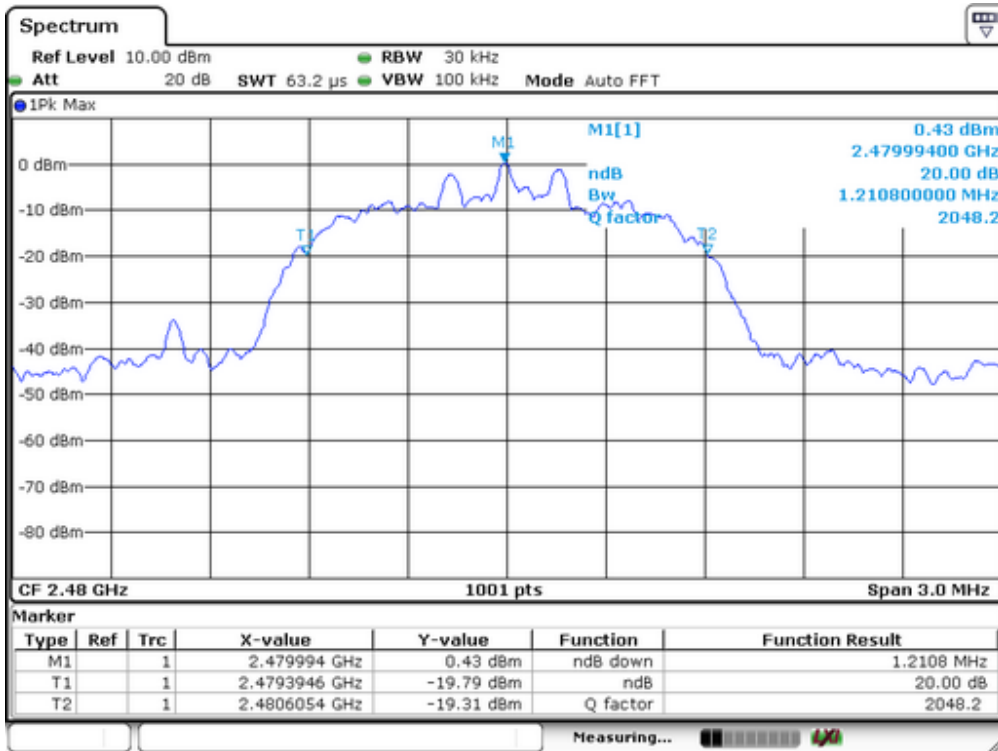

## 8. Quantity of Hopping Channel Test

### 8.1 Measurement Procedure

The EUT was operating in hopping mode or could be controlled its channel. Printed out the test result from the spectrum by hard copy function.

### 8.2 Test SET-UP (Block Diagram of Configuration)

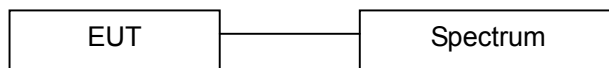

### 8.3 Measurement Equipment Used:

EQUIPMENT TYPE	MFR	MODEL NUMBER	SERIAL NUMBER	LAST CAL.	CAL DUE.
Spectrum Analyzer	Rohde & Schwarz	FSV30	1321.3008K	05/16/2015	05/15/2016
Coaxial Cable	CDS	79254	46107086	05/16/2015	05/15/2016
Antenna Connector	ARTHUR-YANG	2244-N1TG1	N/A	05/16/2015	05/15/2016

Remark: The temporary antenna connector is soldered on the PCB board in order to perform conducted tests and this temporary antenna connector is listed in the equipment list.

### 8.4 Measurement Results:

Refer to attached data chart.

Worst Test Mode	GFSK	Test Date :	July 13, 2015
Test By:	Andy	Temperature :	25 °C
Test Result:	PASS	Humidity :	50 %

Hopping Channel Frequency Range	Quantity of Hopping Channel	Quantity of Hopping Channel
2402-2480	79	> 15

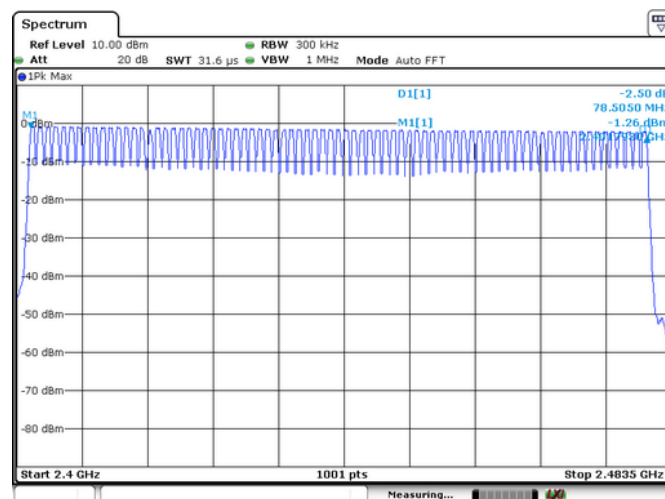

## 9. Time of Occupancy (Dwell Time) test

### 9.1 Test Description

The Equipment Under Test (EUT) was set up to perform the dwell time measurements. The EUT was connected to the spectrum analyzer via a short coax cable. The dwell time is calculated by:

$$\text{Dwell time} = \text{time slot length} * \text{hop rate} / \text{number of hopping channels} * 31.6\text{s}$$

with:

- hop rate =  $1600/2 * 1/\text{s}$  for DH1 packets =  $1600 \text{ s}^{-1}$
- hop rate =  $1600/4 * 1/\text{s}$  for DH3 packets =  $533.33 \text{ s}^{-1}$
- hop rate =  $1600/6 * 1/\text{s}$  for DH5 packets =  $320 \text{ s}^{-1}$
- number of hopping channels = 79
- $31.6 \text{ s} = 0.4 \text{ seconds}$  multiplied by the number of hopping channels =  $0.4 \text{ s} * 79$

The highest value of the dwell time is reported.

### 9.2 Test SET-UP (Block Diagram of Configuration)

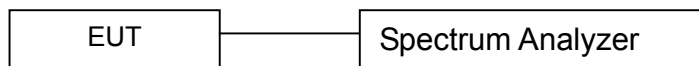

### 9.3 Measurement Equipment Used:

EQUIPMENT TYPE	MFR	MODEL NUMBER	SERIAL NUMBER	LAST CAL.	CAL DUE.
Spectrum Analyzer	Rohde & Schwarz	FSV30	1321.3008K	05/16/2015	05/15/2016
Coaxial Cable	CDS	79254	46107086	05/16/2015	05/15/2016
Antenna Connector	ARTHUR-YANG	2244-N1TG1	N/A	05/16/2015	05/15/2016

Remark: The temporary antenna connector is soldered on the PCB board in order to perform conducted tests and this temporary antenna connector is listed in the equipment list.

### 9.4 Test Requirements / Limits

FCC Part 15, Subpart C, §15.247 (a) (1) (iii)

Frequency hopping systems in the 2400-2483.5 MHz band shall use at least 15 channels. The average time of occupancy on any channel shall not be greater than 0.4 seconds within a period of 0.4 seconds multiplied by the number of hopping channels employed. Since the Bluetooth technology uses 79 channels this period is calculated to be 31.6seconds. Refer to attached data chart.

### 9.3 Test Protocol

Packet type	Time slot length(ms)	Dwell time	Dwell time(ms)
DH1	0.419	time slot length *1600/2 /79 * 31.6	134.08
DH3	1.677	time slot length *1600/4 /79 * 31.6	268.32
DH5	2.925	time slot length *1600/6 /79 * 31.6	312.0

Remark: The results of worst case(GFSK) was recorded.

Test Plot:

DH1:

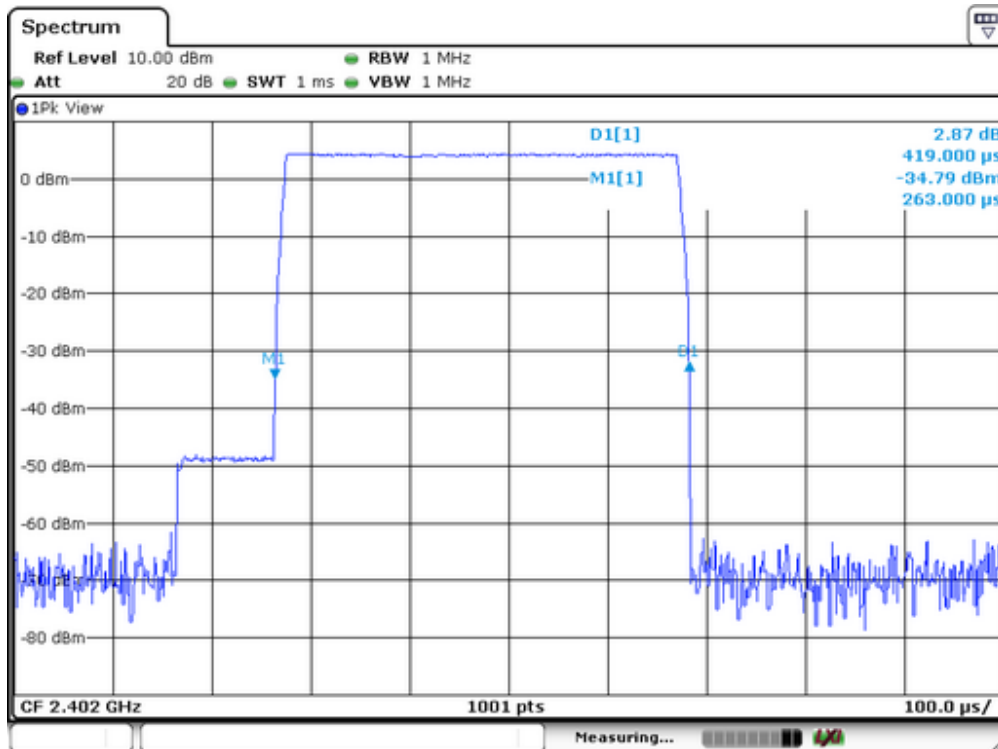



DH3:

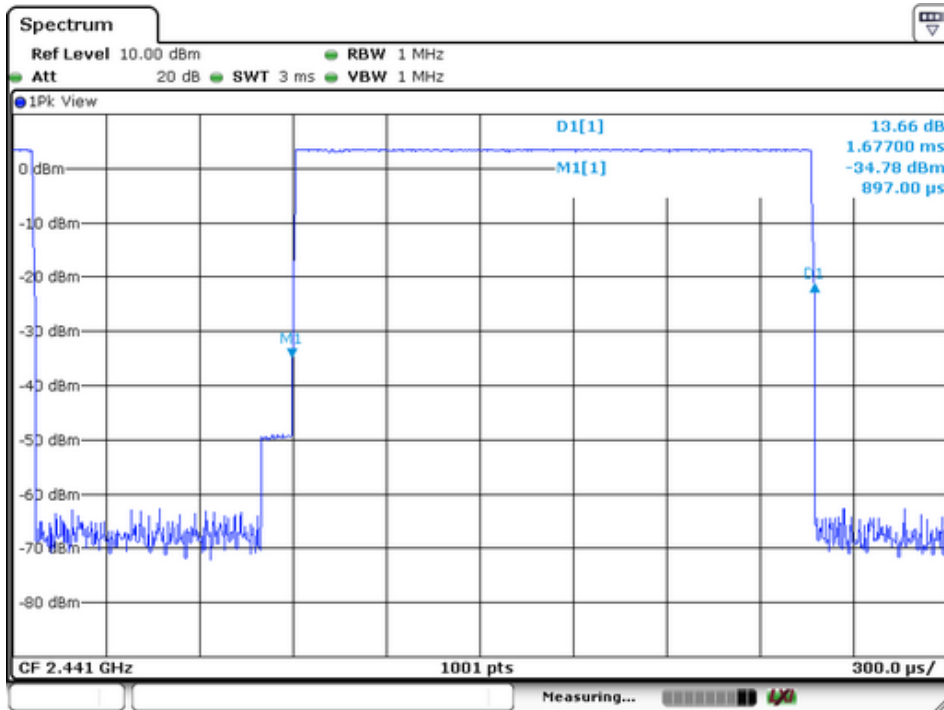

DH5:

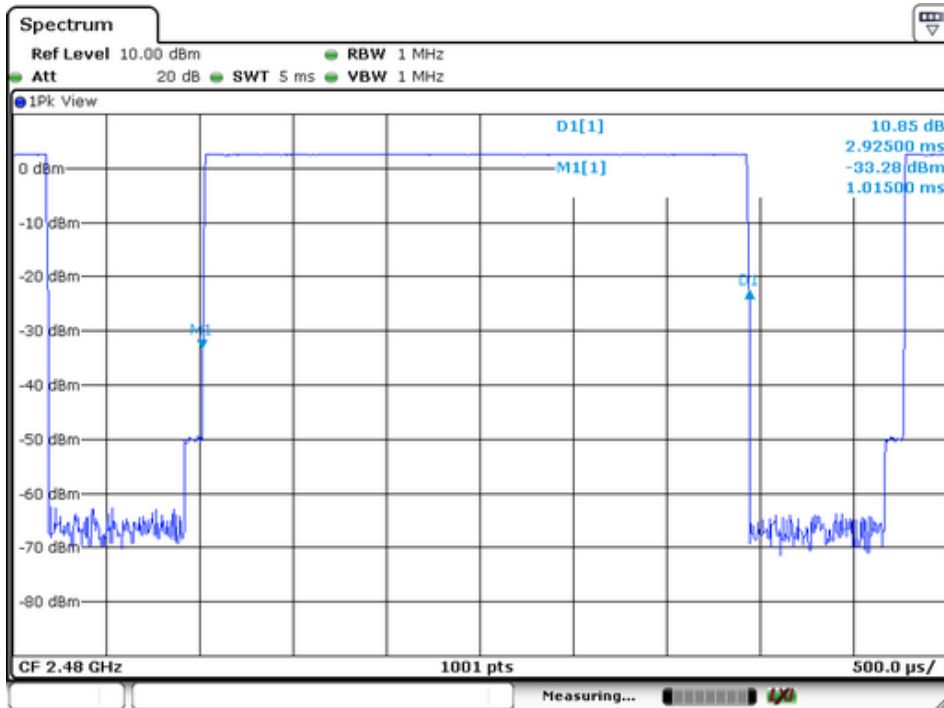

## 10. MAXIMUM PEAK OUTPUT POWER TEST

### 10.1 Measurement Procedure

- a. Check the calibration of the measuring instrument(SA) using either an internal calibrator or a known signal from an external generator.
- b. Turn on the EUT and connect it to measurement instrument. Then set it to any one convenient frequency within its operating range. Set a reference level on the measuring instrument equal to the highest peak value.
- c. The center frequency of the spectrum analyzer is set to the fundamental frequency and using proper RBW and VBW setting.
- d. Measure the captured power within the band and recording the plot.
- e. Repeat above procedures until all frequencies required were complete.

### 10.2 Test SET-UP (Block Diagram of Configuration)

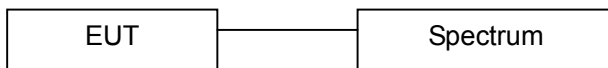

### 10.3 Measurement Equipment Used:

EQUIPMENT TYPE	MFR	MODEL NUMBER	SERIAL NUMBER	LAST CAL.	CAL DUE.
Spectrum Analyzer	Rohde & Schwarz	FSV30	1321.3008K	05/16/2015	05/15/2016
Coaxial Cable	CDS	79254	46107086	05/16/2015	05/15/2016
Antenna Connector	ARTHUR-YANG	2244-N1TG1	N/A	05/16/2015	05/15/2016

Remark: The temporary antenna connector is soldered on the PCB board in order to perform conducted tests and this temporary antenna connector is listed in the equipment list.

**10.4 Measurement Results:**

Refer to attached data chart.

Spectrum Detector:	PK	Test Date :	July 13, 2015
Test By:	Andy	Temperature :	25 °C
Test Result:	PASS	Humidity :	50 %
Modulation:	GFSK		

Channel number	Channel Frequency (MHz)	Peak Power output(dBm)	Peak Power output(mW)	Peak Power Limit(mW)	Pass/Fail
1	2402	<b>4.43</b>	<b>2.773</b>	1000	PASS
40	2441	3.58	2.280	1000	PASS
79	2480	2.77	1.892	1000	PASS

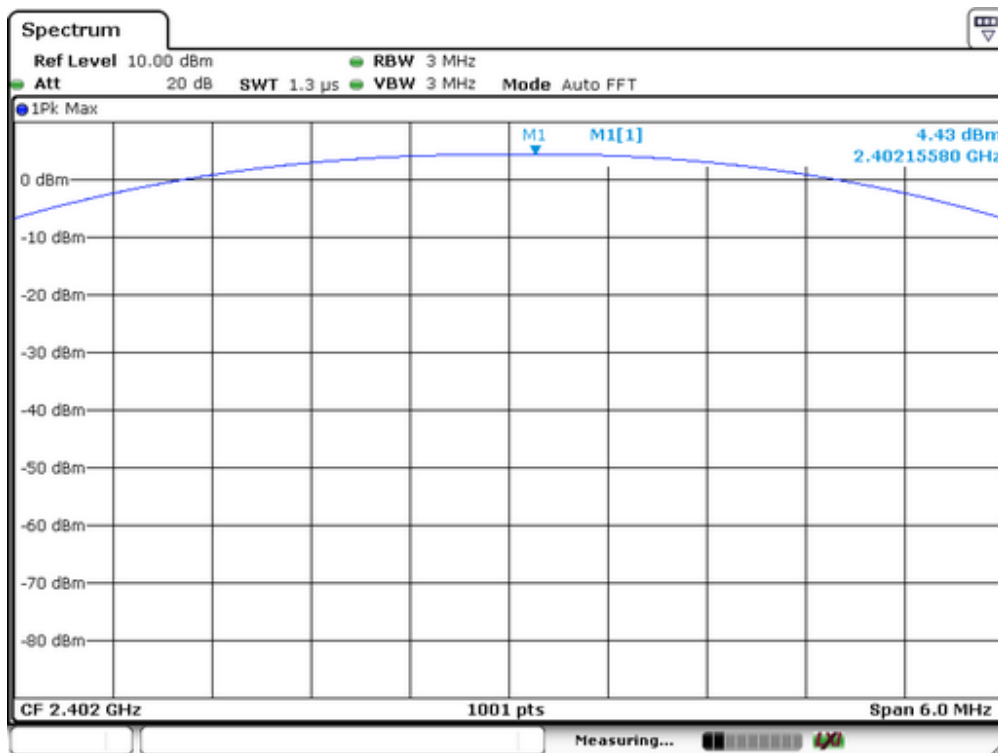

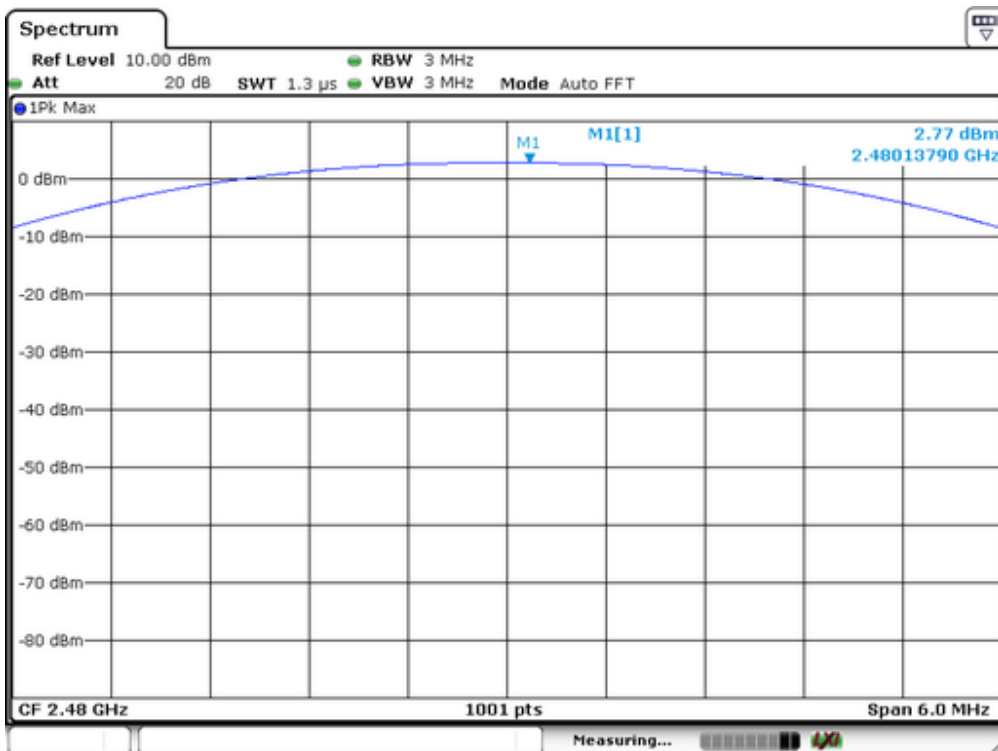
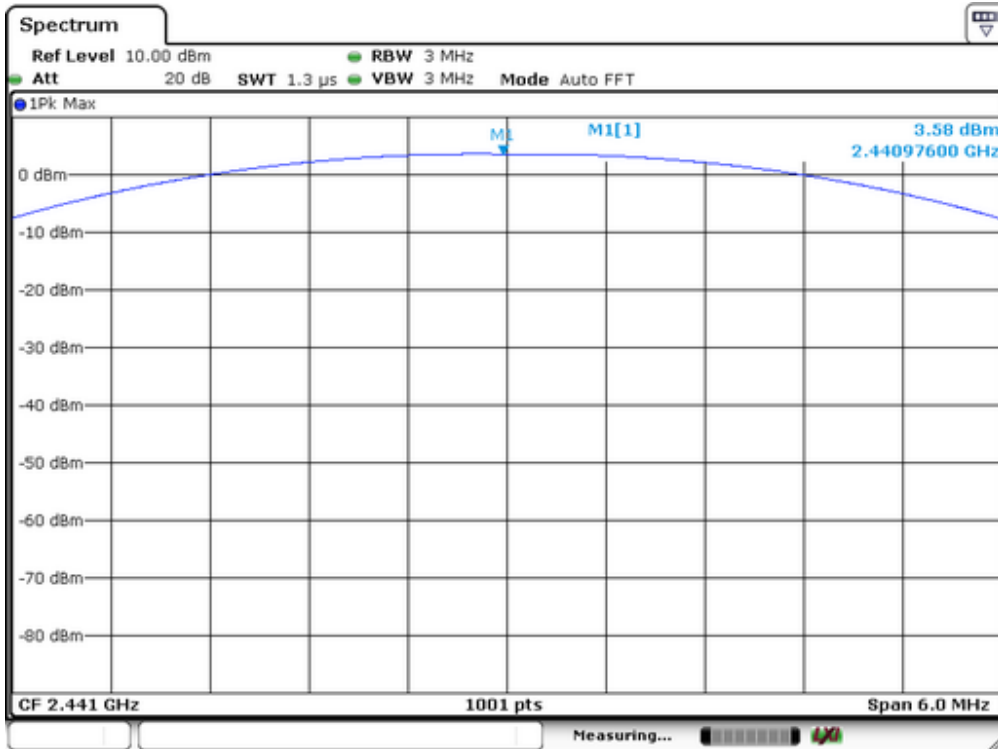

Spectrum Detector: PK                      Test Date : July 13, 2015  
 Test By: Andy                              Temperature : 25 °C  
 Test Result: PASS                        Humidity : 50 %  
 Modulation:  $\Pi/4$ -DQPSK

Channel number	Channel Frequency (MHz)	Peak Power output(dBm)	Peak Power output(mW)	Peak Power Limit(mW)	Pass/Fail
1	2402	3.29	2.133	125	PASS
40	2441	2.42	1.746	125	PASS
79	2480	1.44	1.393	125	PASS

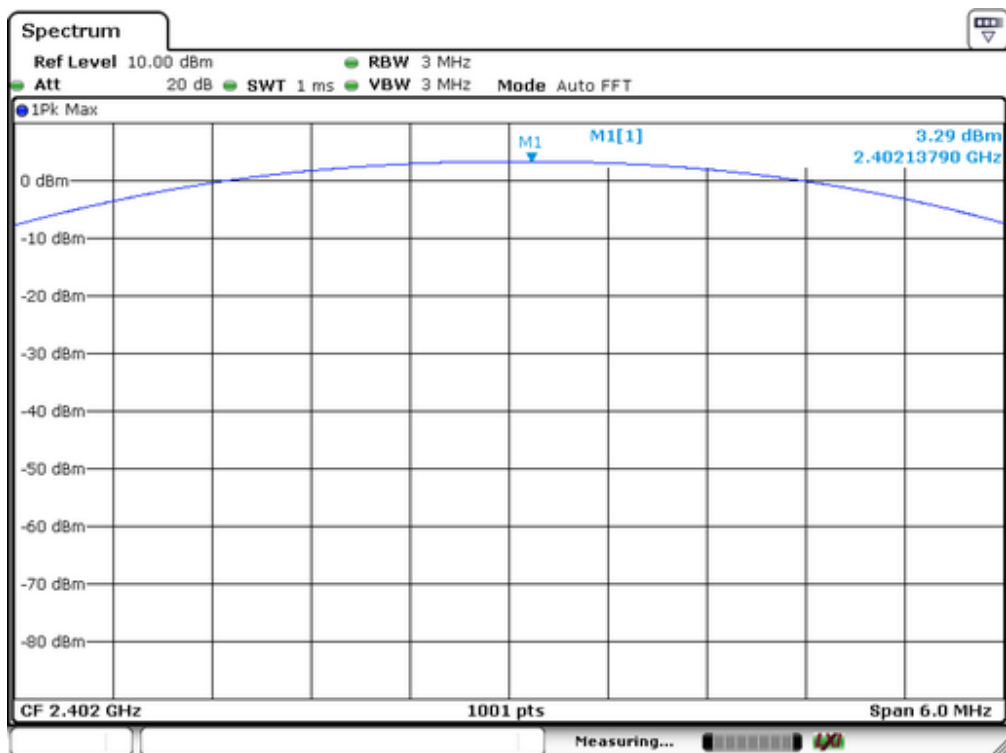

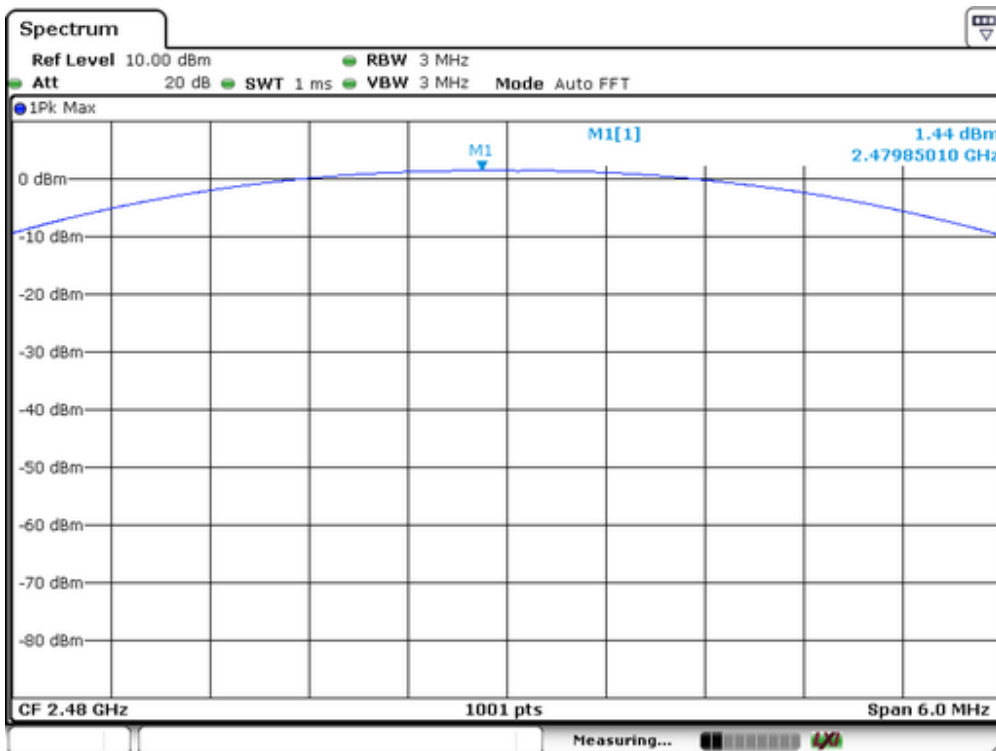
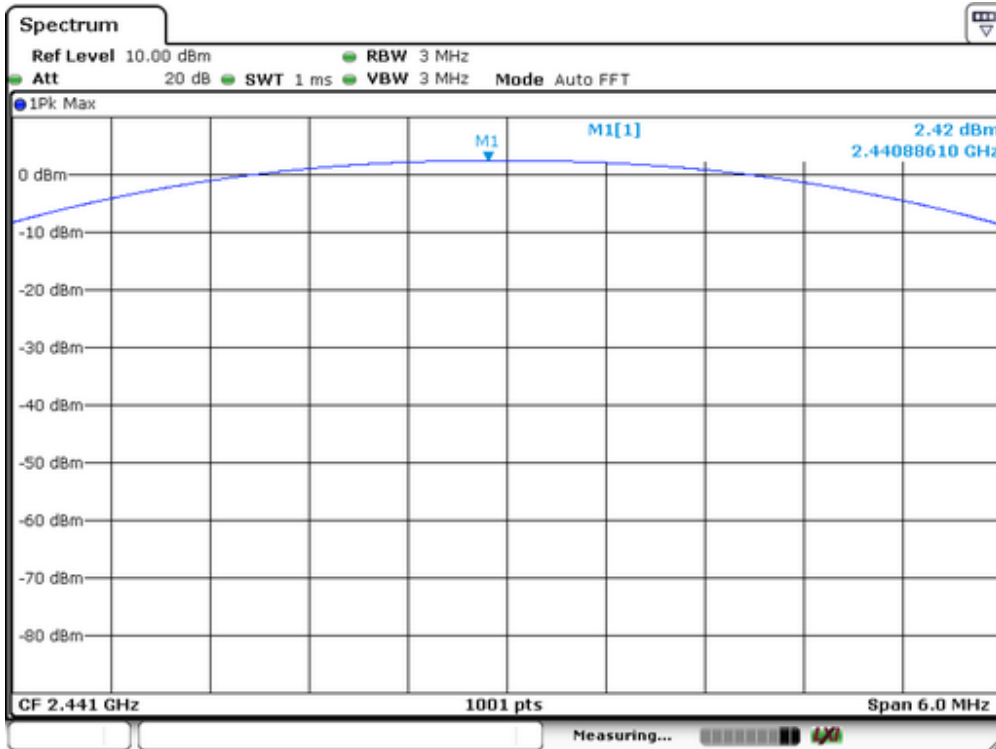

Spectrum Detector: PK                      Test Date : July 13, 2015  
 Test By: Andy                              Temperature : 25 °C  
 Test Result: PASS                        Humidity : 50 %  
 Modulation: 8DPSK

Channel number	Channel Frequency (MHz)	Peak Power output(dBm)	Peak Power output(mW)	Peak Power Limit(mW)	Pass/Fail
1	2402	3.53	2.254	125	PASS
40	2441	2.58	1.811	125	PASS
79	2480	1.60	1.445	125	PASS

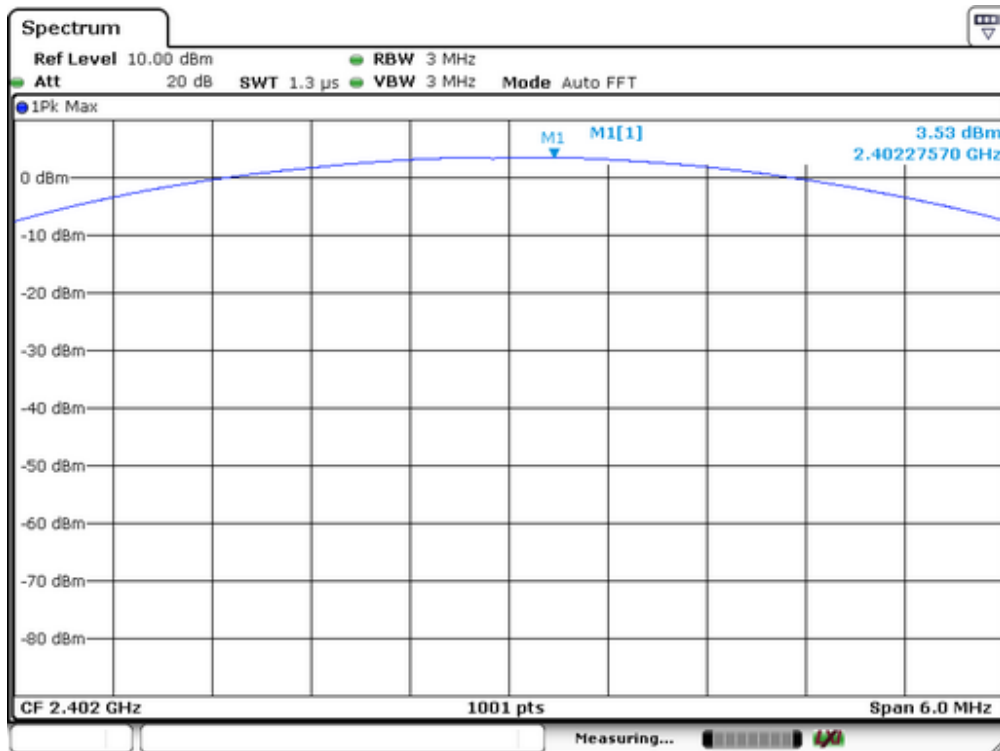

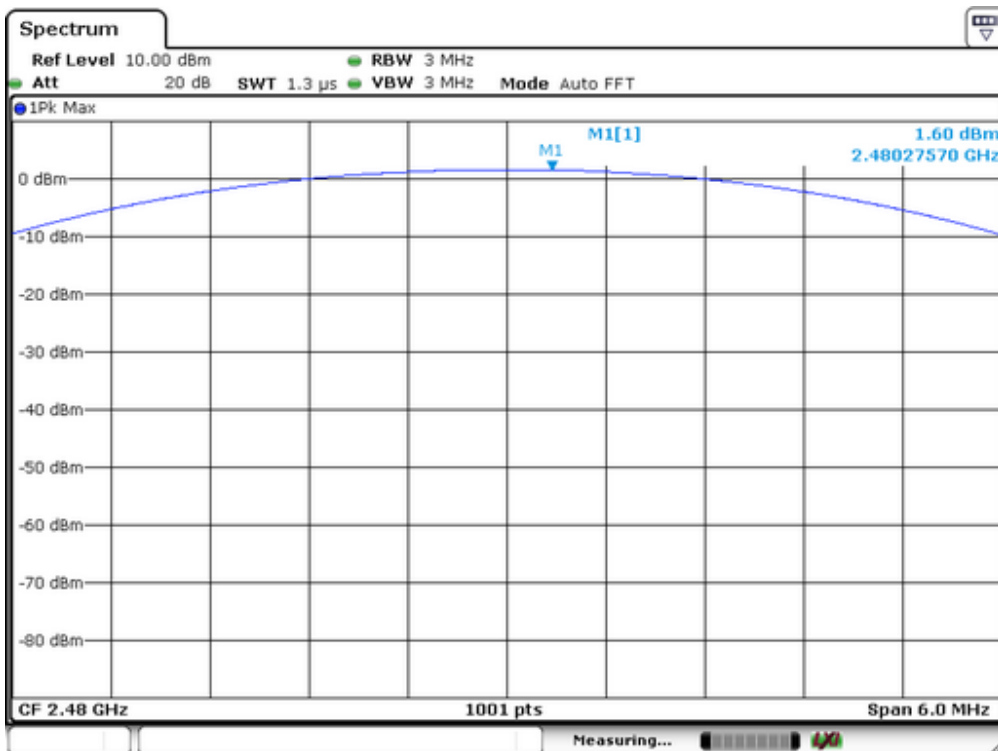
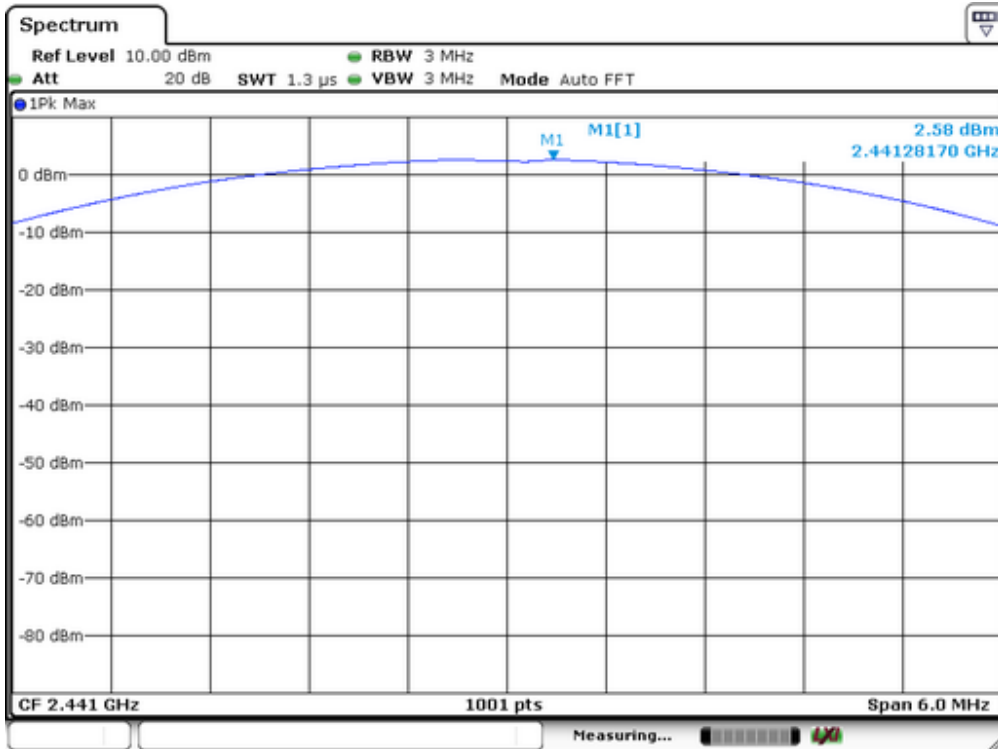



## 11. Band EDGE test

### 11.1 Measurement Procedure

#### For Conducted Test

1. The transmitter output is connected to a spectrum analyzer. The resolution bandwidth is set to 100KHz. The video bandwidth is set to 300KHz.
2. The spectrum from 30MHz to 26 GHz is investigated with the transmitter set to the lowest, middle, and highest channels.

EMI Test Receiver	Setting
Attenuation	Auto
RBW	100KHz
VBW	300KHz
Detector	Peak
Trace	Max hold

#### For Radiated emission Test

The EUT was placed on a styrofoam table which is 1.5m above ground plane.

The measurement procedure at the band edges was simplified by performing the measurement in just one plot. Both, the in-band-emission and the unwanted emission were encompassed by the span. After trace stabilization, the maximum peak was determined by a peak detector and the value was marked by an appropriate limit line. The second limit line, which is 20dB below the first, marks the limit for the emissions in the unrestricted band. A maximum-peak-detector marks the highest emission in the unrestricted band next to the band edge.

The measurements were performed at the lower end of the 2.4GHz band.

Use the following spectrum analyzer settings:

For Restricted Band, When spectrum scanned above 1GHz setting resolution bandwidth 1MHz, video bandwidth 3MHz:

EMI Test Receiver	Setting
Attenuation	Auto
RBW	1MHz
VBW	3MHz
Detector	Peak
Trace	Max hold

For Non-Restricted Band, When spectrum scanned above 1GHz setting resolution bandwidth 100KHz, video bandwidth 300KHz:

EMI Test Receiver	Setting
Attenuation	Auto
RBW	100KHz
VBW	300KHz
Detector	Peak
Trace	Max hold

### 11.2 Test SET-UP (Block Diagram of Configuration)

For Conducted Test

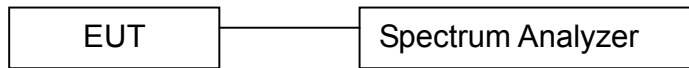

For Radiated emission Test

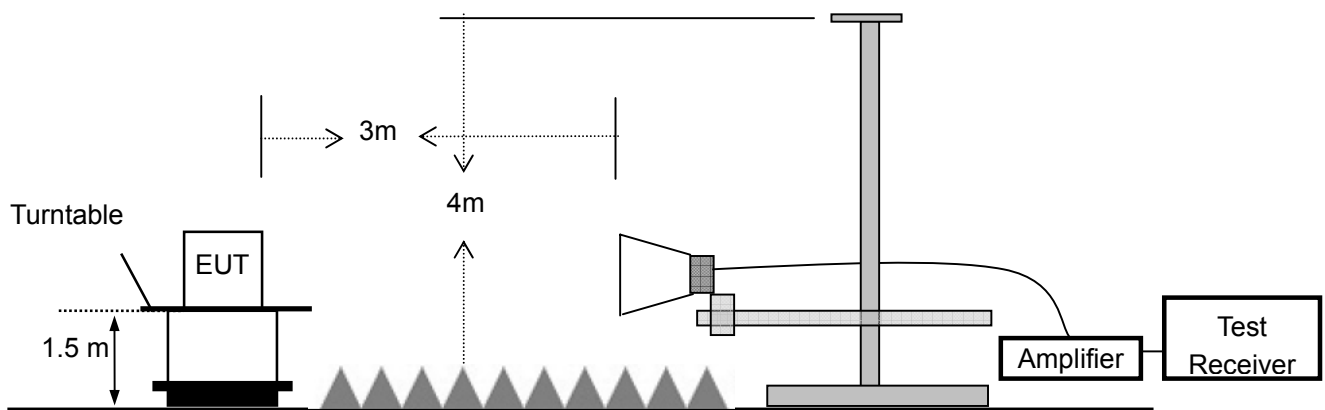

### 11.3 Measurement Equipment Used: For Conducted Test

EQUIPMENT TYPE	MFR	MODEL NUMBER	SERIAL NUMBER	LAST CAL.	CAL DUE.
Spectrum Analyzer	Rohde & Schwarz	FSV30	1321.3008K	05/16/2015	05/15/2016
Coaxial Cable	CDS	79254	46107086	05/16/2015	05/15/2016
Antenna Connector	ARTHUR-YANG	2244-N1TG1	N/A	05/16/2015	05/15/2016

Remark: The temporary antenna connector is soldered on the PCB board in order to perform conducted tests and this temporary antenna connector is listed in the equipment list.

For Radiated emission Test

Item	Equipment	Manufacturer	Model No.	Serial No.	Characteristics	Last Cal.	Cal. Interval
1	Signal Analyzer	Rohde & Schwarz	FSV30	103040	9KHz-40GHz	12/29/2014	1 Year
2	Horn Antenna	Schwarzbeck	BBHA9120D	9120D-1272	1GHz-18GHz	12/29/2014	1 Year
3	Power Amplifier	LUNAR EM	LNA1G18-40	J10100000081	1GHz-26.5GHz	12/29/2014	1 Year
4	Cable	H+S	CBL-26	N/A	1GHz-26.5GHz	12/29/2014	1 Year
5	Cable	H+S	CBL-26	N/A	1GHz-26.5GHz	12/29/2014	1 Year
6	Cable	H+S	CBL-26	N/A	1GHz-26.5GHz	12/29/2014	1 Year

**11.4 Measurement Results:**

Refer to attached data chart.

Spectrum Detector:	PK	Test Date :	July 13, 2015
Test By:	Andy	Temperature :	25 °C
Test Result:	PASS	Humidity :	50 %

1. Conducted Test

For Non-Hopping mode:

Frequency (MHz)	Modulation	Peak Power Output(dBm)	Emission read Value(dBm)	Result of Band edge(dBc)	Band edge Limit(dBc)
2399.99	GFSK	4.28	-41.62	45.9	>20dBc
2399.98	pi/4-DQPSK	2.51	-43.62	46.13	>20dBc
2399.98	8DPSK	2.57	-43.91	46.48	>20dBc
2483.98	GFSK	2.58	-60.43	63.01	>20dBc
2484.00	pi/4-DQPSK	0.75	-58.02	58.77	>20dBc
2484.01	8DPSK	0.84	-58.3	59.14	>20dBc

For Hopping mode:

Frequency (MHz)	Modulation	Peak Power Output(dBm)	Emission read Value(dBm)	Result of Band edge(dBc)	Band edge Limit(dBc)
2399.98	GFSK	4.24	-42.22	46.46	>20dBc
2399.98	pi/4-DQPSK	2.25	-43.83	46.08	>20dBc
2399.99	8DPSK	2.57	-43.76	46.33	>20dBc
2486.96	GFSK	2.56	-60.67	63.23	>20dBc
2483.51	pi/4-DQPSK	0.76	-58.4	59.16	>20dBc
2484.31	8DPSK	0.8	-59.69	60.49	>20dBc

2. Radiated emission Test

**Worst test modulation GFSK**

For Non-Hopping mode:

Frequency (MHz)	Antenna polarization (H/V)	Emission (dBuV/m)		Band edge Limit (dBuV/m)		Margin (dB)	
		PK	AV	PK	AV	PK	AV
2398.456	H	66.33	44.01	74	54	-7.67	-9.99
2399.157	V	61.72	39.42	74	54	-12.28	-14.58
2484.013	H	65.04	45.16	74	54	-8.96	-8.84
2483.895	V	59.14	38.72	74	54	-14.86	-15.28

For Hopping mode:

Frequency (MHz)	Antenna polarization (H/V)	Emission (dBuV/m)		Band edge Limit (dBuV/m)		Margin (dB)	
		PK	AV	PK	AV	PK	AV
2399.001	H	65.72	45.32	74	54	-8.28	-8.68
2398.413	V	60.34	40.78	74	54	-13.66	-13.22
2483.753	H	64.18	44.08	74	54	-9.82	-9.92
2484.015	V	59.83	37.06	74	54	-14.17	-16.94

## **12. Antenna Application**

### **12.1 Antenna requirement**

The EUT'S antenna is met the requirement of FCC part 15C section 15.203 and 15.247.

FCC part 15C section 15.247 requirements:

Systems operating in the 2402-2480MHz band that are used exclusively for fixed, point-to-point operations may employ transmitting antennas with directional gain greater than 6dBi provided the maximum peak output power of the intentional radiator is reduced by 1dB for every 3dB that the directional gain of the antenna exceeds 6dBi.

### **12.2 Result**

The EUT used inverted-E antenna. The antenna's gain is 4dBi and meets the requirement.

### General Appearance of the EUT



