

Controls and Functions

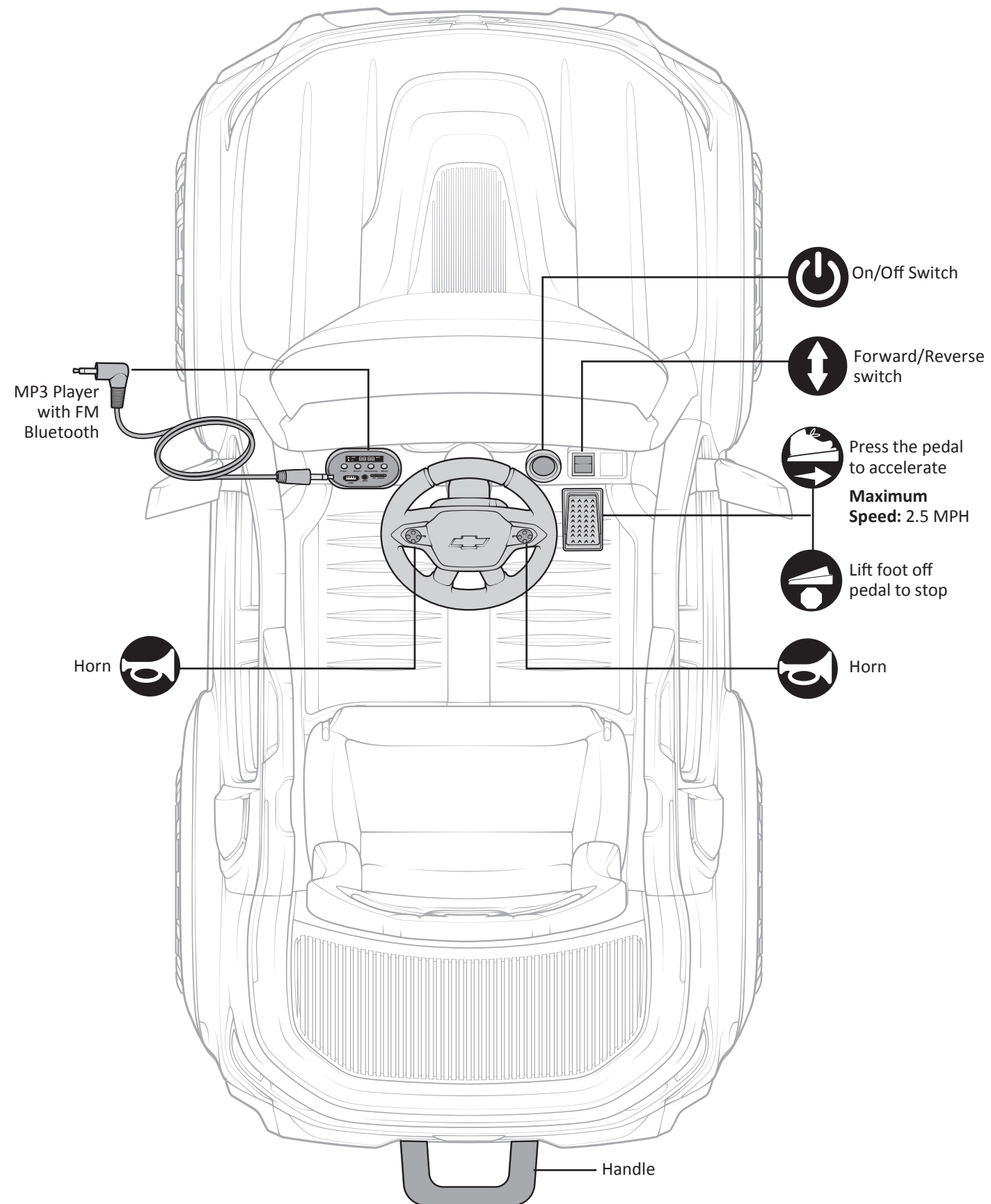

Remote Control Use and Functions

⚠ WARNING

- DO NOT mix old and new batteries.
- DO NOT mix alkaline, standard (carbon-zinc), or rechargeable (nickel-cadmium) batteries.
- Non-rechargeable batteries are not to be recharged. Batteries are to be inserted with the correct polarity. Exhausted batteries are to be removed from the toy. The supply terminals are not to be short-circuited. Rechargeable batteries are only to be charged under adult supervision.
- Rechargeable batteries are to be removed from the toy before being charged.

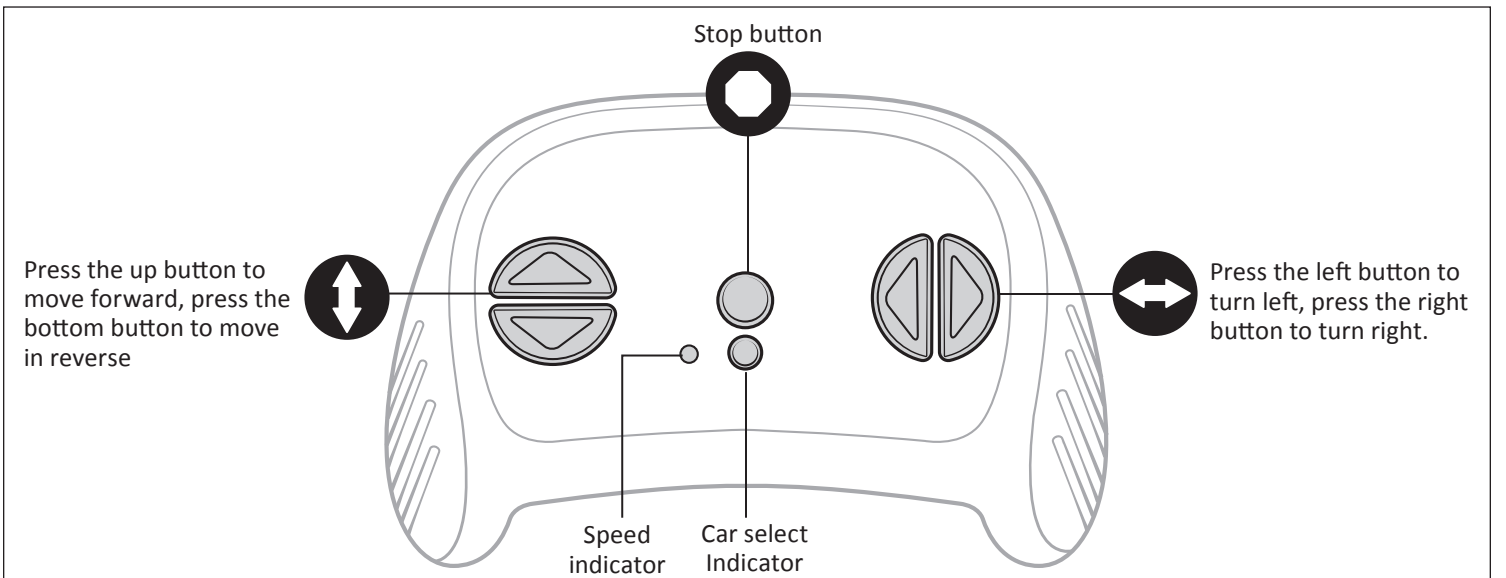

Insert the batteries

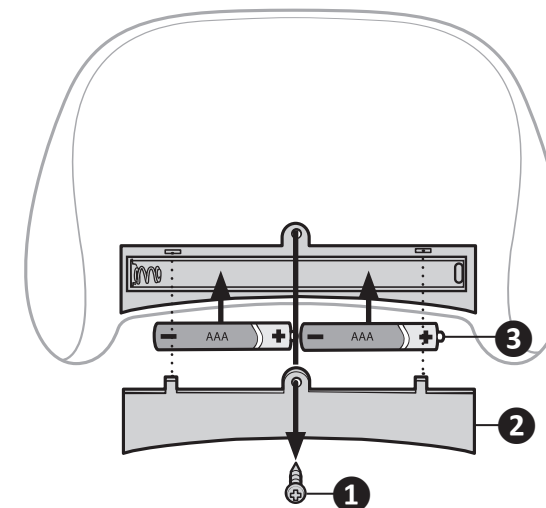

- 1 Remove the small screw from the battery compartment cover.
- 2 Lift the battery cover off the remote control.
- 3 Insert two AAA-size batteries into the battery compartment as shown. **Note:** Batteries NOT included.
- 4 Replace the battery compartment cover and fasten with the small screw you removed in step one.

Pairing the remote control to the ride-on

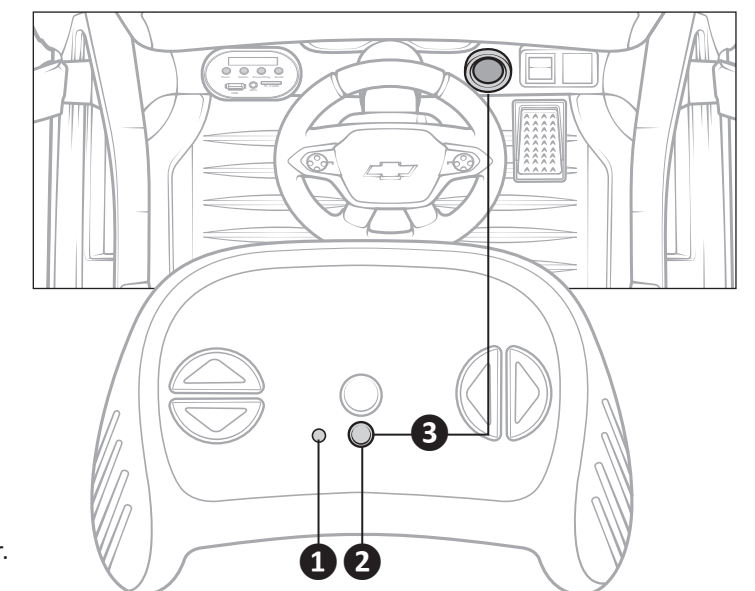

- 1 The speed indicators will flash 3 times when the batteries are installed.
- 2 Press the Car Select indicator for approximately 2 seconds. The Car Select indicator will flash.
- 3 Press the On/Off switch on the car immediately. If the Car Select indicator is not illuminated, repeat step 2.