

SPECIFICATION

UNIMAX

Q6508 Antenna

Product approval sheet

Customer		Band	4G、5G
Project	Q6508	Colour	Black

Customer check:

Reach requirement of customer: OK NG

Contents

1 General description.....2

1.1 Antenna appearing diagram..... 3

1.2 Matching circuits.....4

1.3 Antenna PORT.....7

1.4 Antenna location.....7

1.5 RF port.....8

2 Electrical performance.....8

2.1 VSWR.....8

2.2 Efficiency &Gain..... 13

2.3 3D Pattern.....32

1 General description

1.1 Antenna appearing diagram

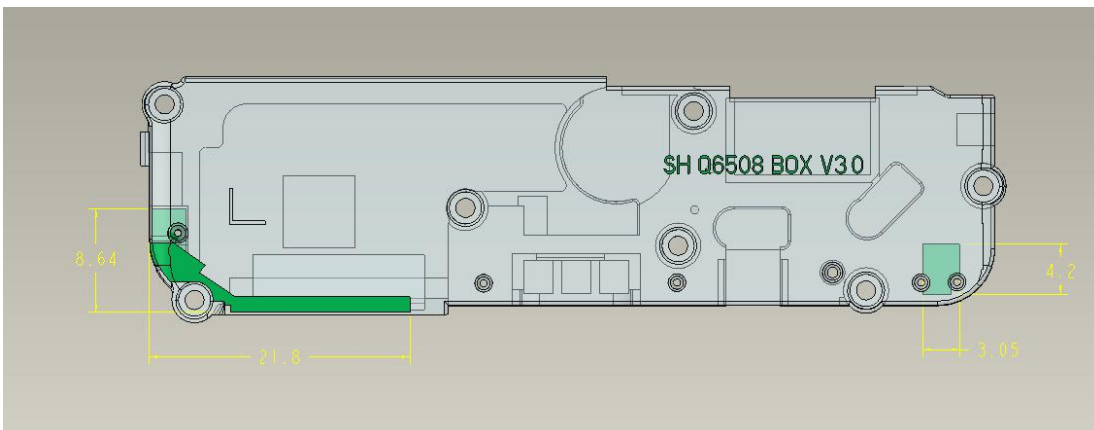
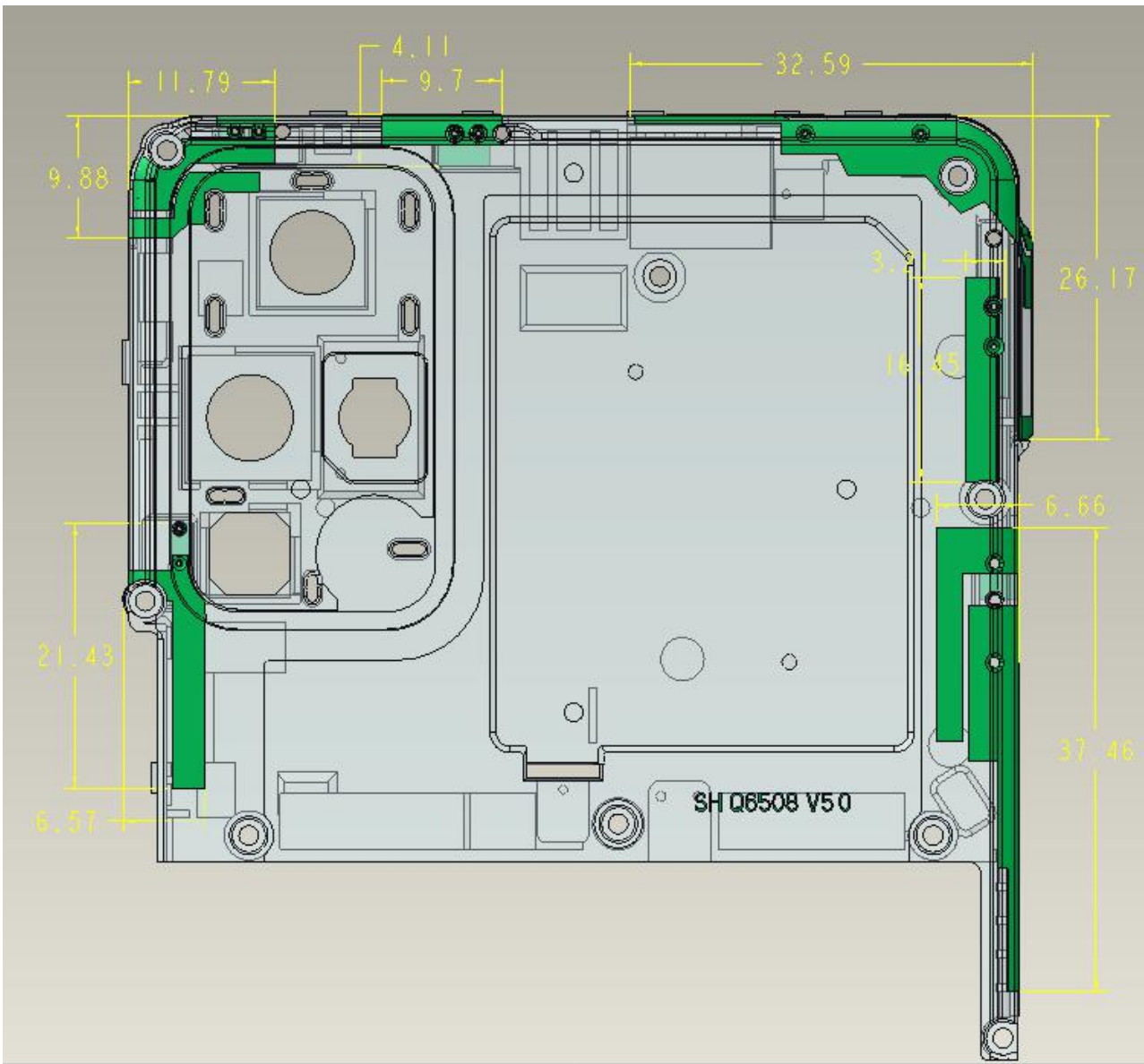

1.2 Antenna Matching circuits

ANT1

A	B	C
ANT1主路匹配		
C118		22pf
L112		6.9NH
C117		0Ω
C119		NC
L104		47nh
L114		nc
C110		22pF
L113		100nH
R107		0Ω

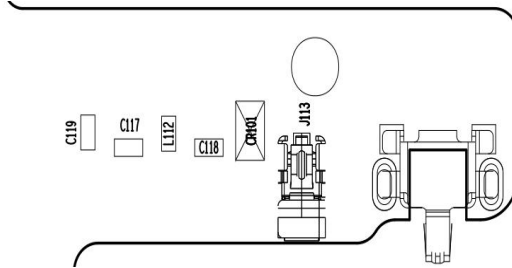

ANT1 Tuner匹配		
RF1	C113	2.7pf
RF2	C114	1pF
RF3	C115	1.5pF
RF4	L111	NC
RF1	2/3/4/5G B5/B8+所有中高频	
RF2	4G:13/14(746-798) 5G:13/14(746-798)	
RF3	4G:12/17/28(699-746)(703-803) 5G:28	
RF4	4G:71(617-698) 5G:71(617-698)	

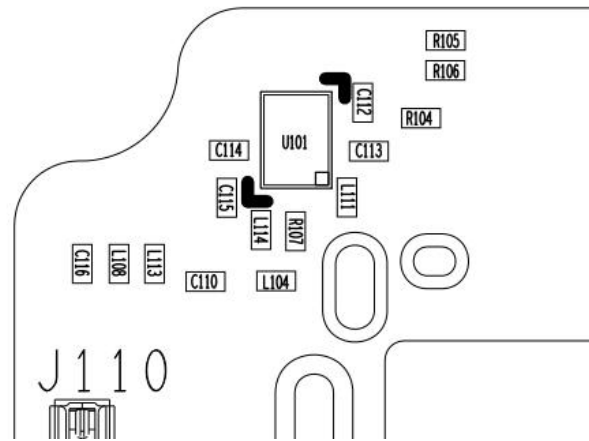

ANT2

L2	ANT2匹配	
L3	CR102	0.75PF
L4	L102	NC
L5	L101	1.5nh
L6	C109	nc
L7		

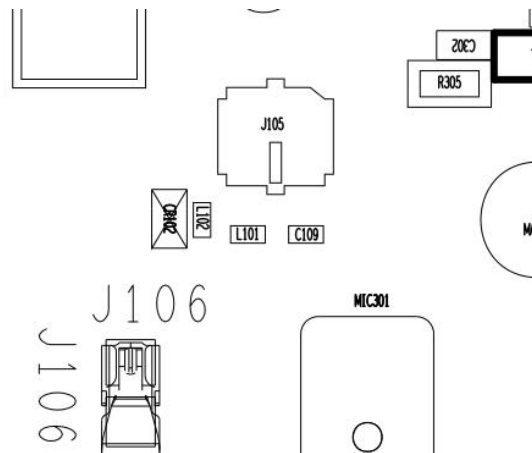

ANT3

808-SUB_V1.0_0908

ANT3匹配		
C106		0.5PF
C120		1.8nh
L110		nc
L107		0Ω
L116		0Ω
L109		nc

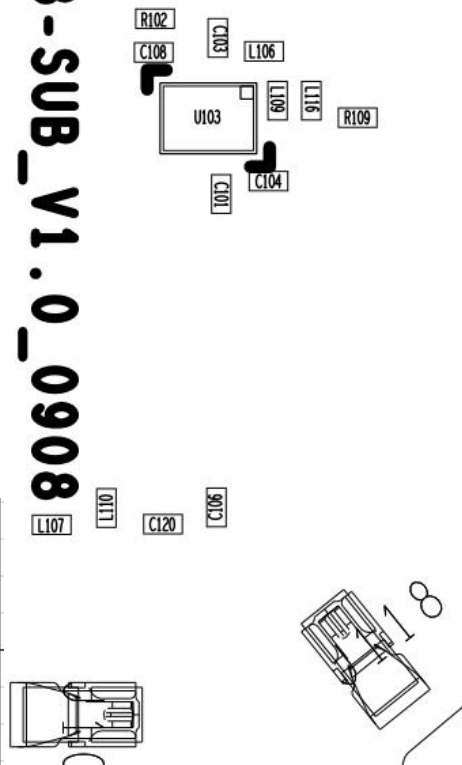

ANT4

ANT4天线匹配		
L0108		nc
L0107		0Ω
L0109		nc

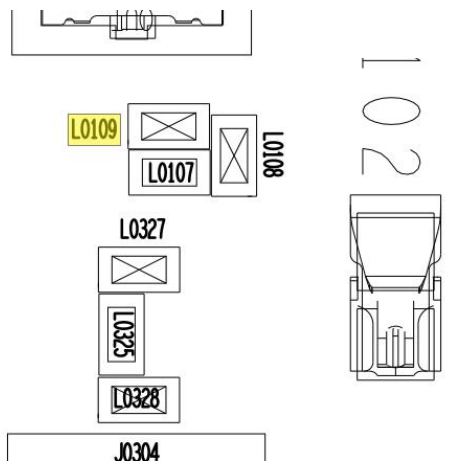

ANT5

ANT5天线匹配	
L0105	0Ω
L0104	18NH
L0101	0Ω
L0106	0.5PF
L0102	0Ω
C0102	22pF
R0100	68nH
L0113	1.2NH
R0101	15NH
L0114	56nh
L0115	22nh

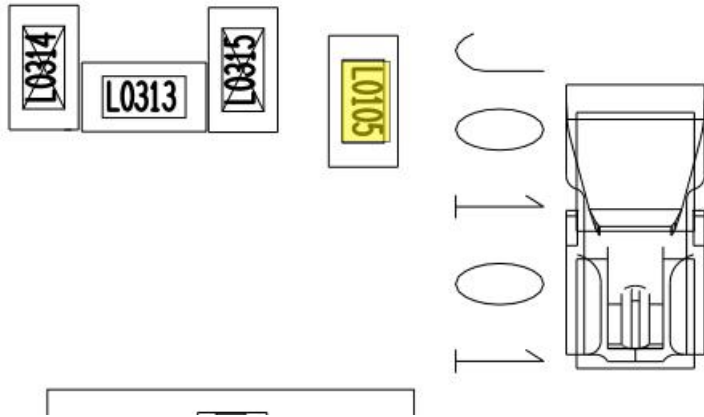

ANT7

ANT7天线匹配	
L0120	22PF
L0117	22PF
L0103	100NH
L0100	100NH
C0101	22PF
C0100	22PF
L0110	68NH
L0119	NC
L0118	0Ω
L0121	NC

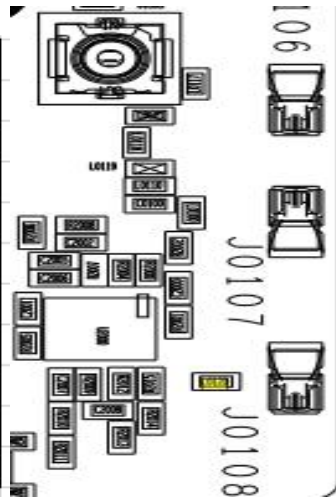

ANT8

ANT8天线匹配	
R0314	0Ω
R0313	0Ω
L0351	NC
L0349	1.8NH
L0352	NC

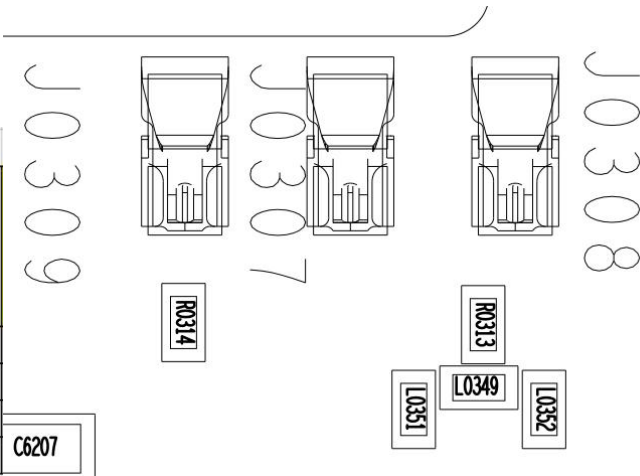

ANT9

ANT9天线匹配	
R0317	0Ω
L0365	NC
L0363	1NH
L0366	NC

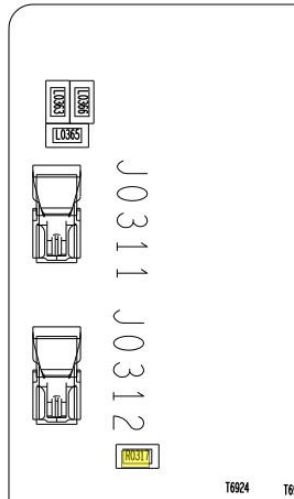

ANT10

ANT10天线匹配		
5	R0321	22pf
6	R0320	22pf
7	L0380	100nh
8	C0300	22pf
9	L0381	68nh
0	L0376	nc
1	L0375	0Ω
2	L0377	nc

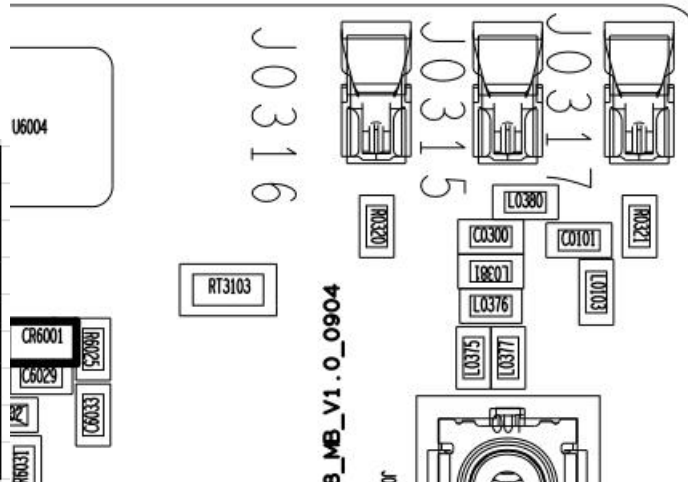

1.3 Antenna PORT

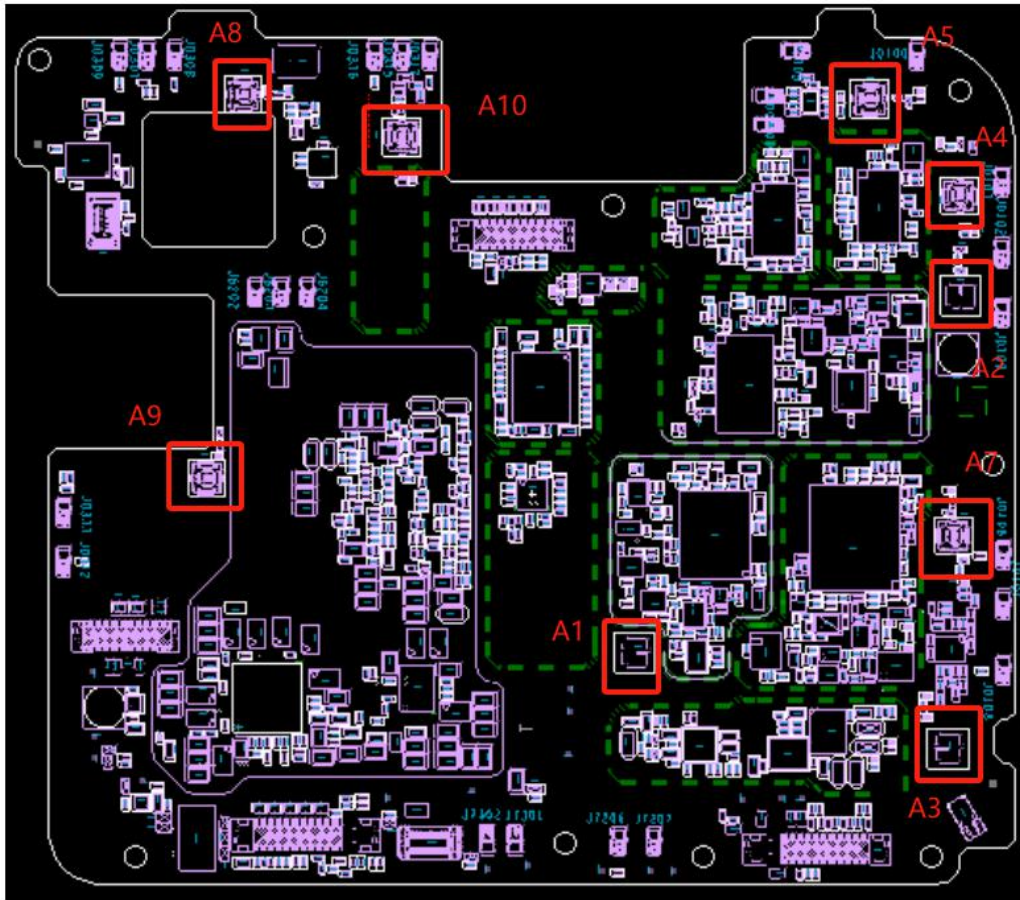

ANT Location	NR	LTE	WCDMA	GSM	GPS	WiFi	BT
ANT1	TRX: N5 PRX MIMO: N2/N66	TRX: B5/12/13 PRX MIMO: B2/4/66/7/1/3	TRX: W5/8	B5/8			
ANT2	PRX: N48/77/78	PRX: B48					
ANT3	TRX: N2/66 DRX2: N48/77/78	TRX: B2/4/66/1/3/7 DRX2: B48	TRX: W1/2	B1/2			
ANT4	TRX0:N48/77/78	TRX0: B48					
ANT5	DRX:N5/2/66	DRX: B5/12/13/2/4/66/1/3/7	DRX: 1/2/5/8	B1/2/5/8			
ANT7	DRX(ENDC):N2/66	DRX: B2/4/66/1/3/7 ENDC TX: B2/66					
ANT8					GPS	WIFI CH0	BT
ANT9						WIFI CH1	
ANT10	TRX1: N48/77/78	TRX1: B48					

1.4 Antenna location

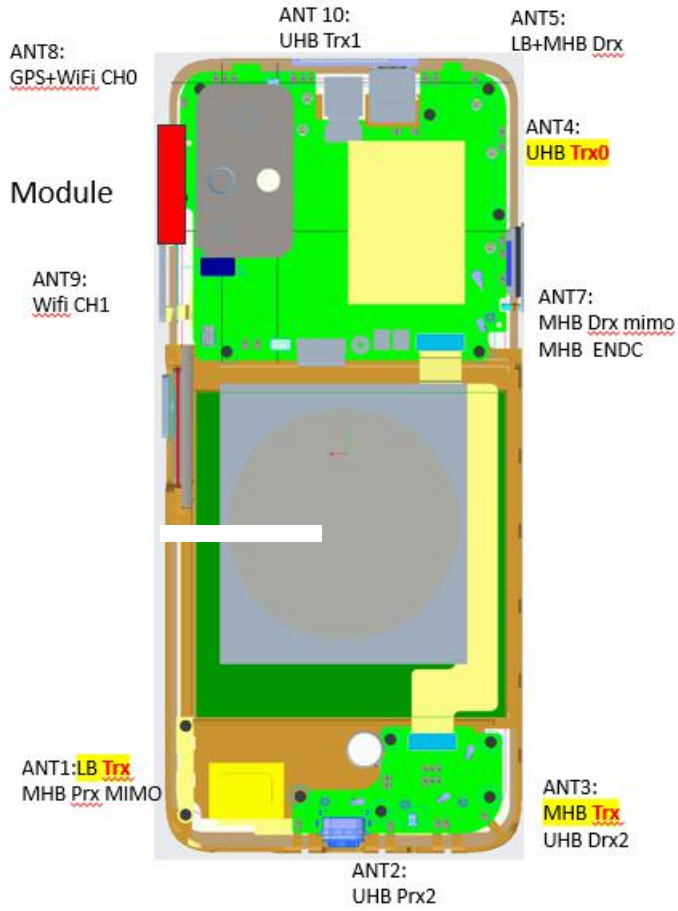

Antenna Location	Support Function	Top Side(mm)	Bottom Side(mm)	Left Side(mm)	Right Side(mm)
ANT1	LB TRX+MHB PRX MIMO	106	1.1	1.1	47.5
ANT2	UHB PRX2	162.2	1.1	30.5	17
ANT3	MHB TRX+UHB DRX2	134.3	1.1	60.9	1.1
ANT4	UHB TRX0	15.4	133.5	70	3.6
ANT5	LB DRX+MHB DRX	2.3	152.5	43.8	2.3
ANT7	MHB DRX MIMO+MHB ENDC	36.3	92.2	68	2.3
ANT8	GPS+WIFI CH0	2.3	152.5	2.3	62.6
ANT9	WIFI CH1	39.7	108.2	6.1	68.4
ANT10	UHB TRX1	2.3	160	23.2	44.8

1.5 RF port

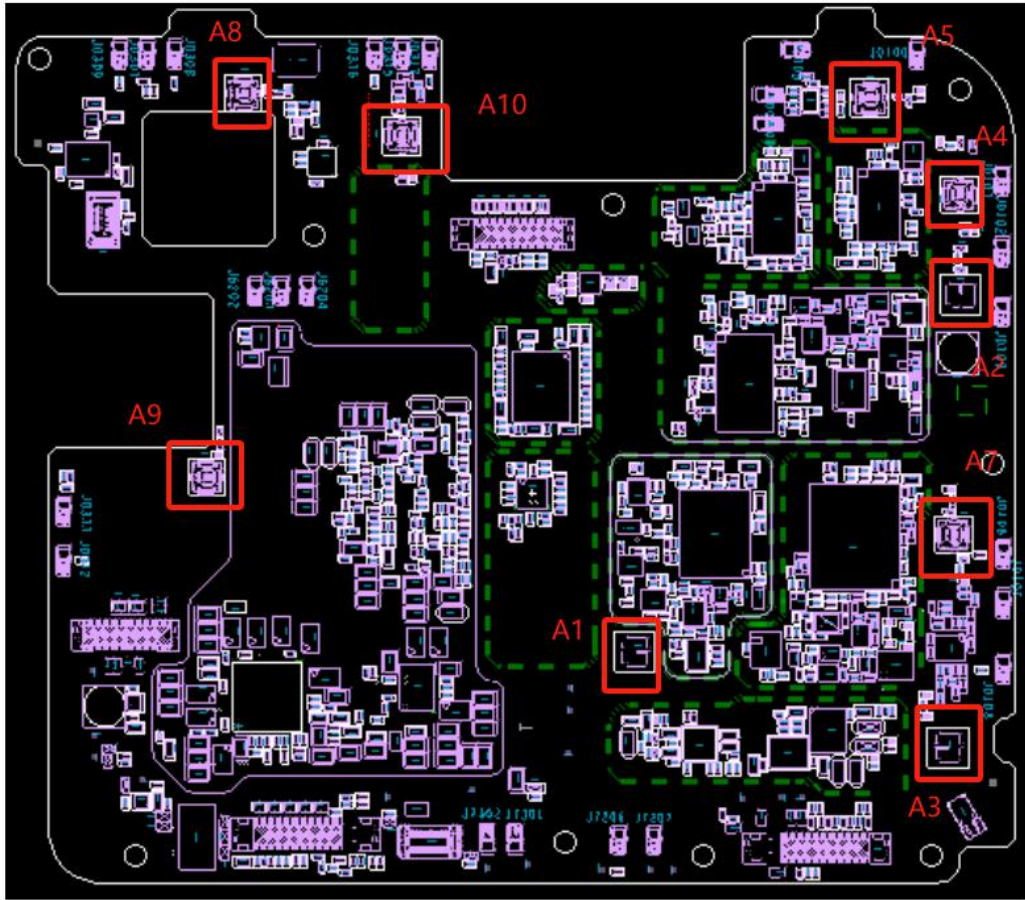

2 Electrical performance

2.1 VSWR

ANT1

RF1

RF2

Confidential Information

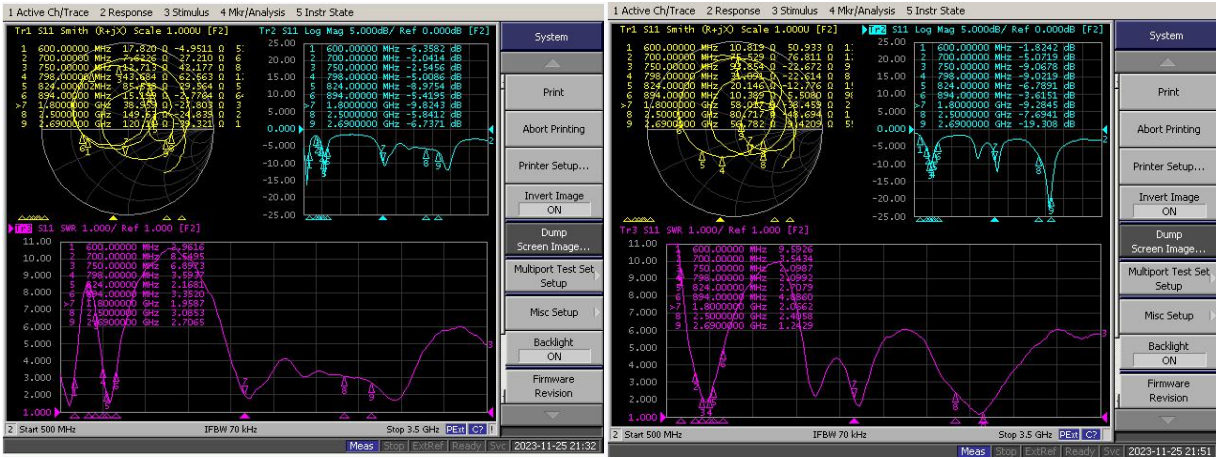

RF3

RF4

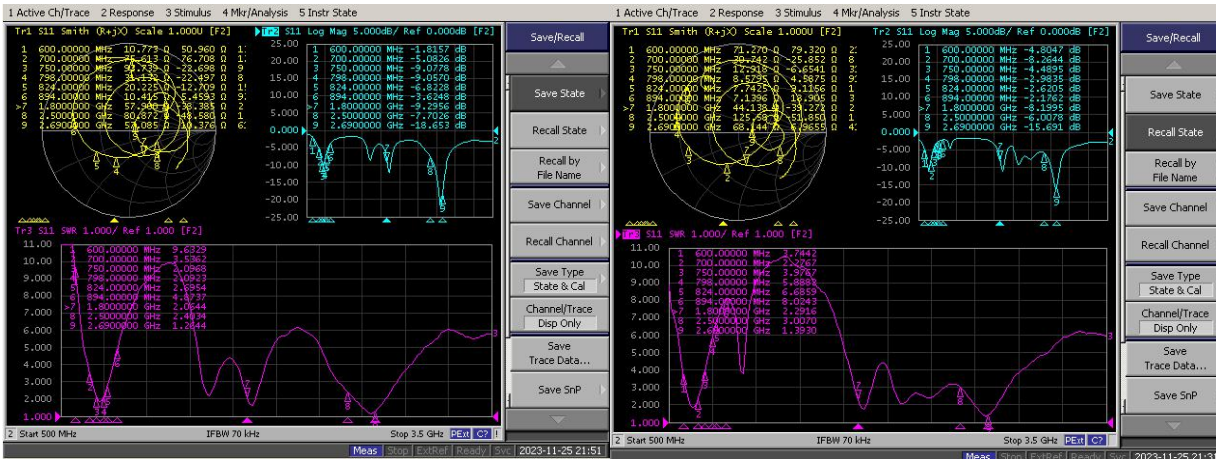

ANT2



ANT3

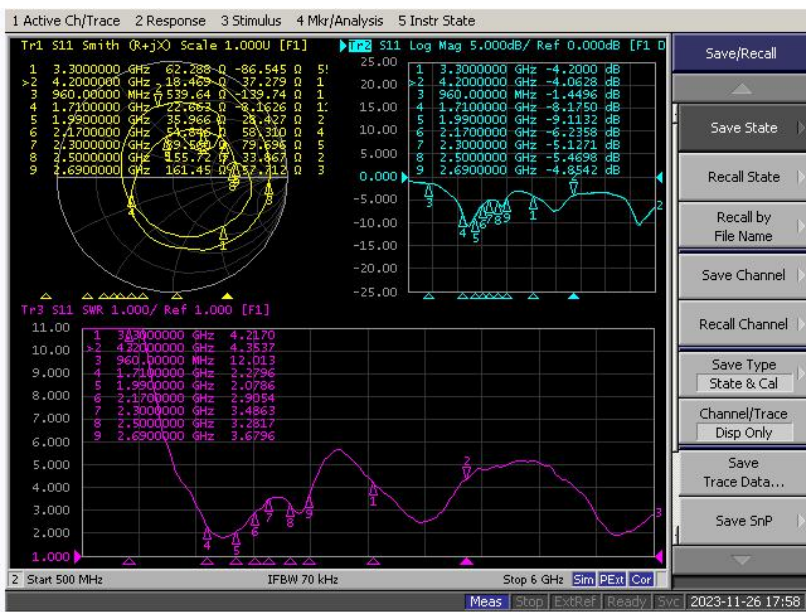

ANT4

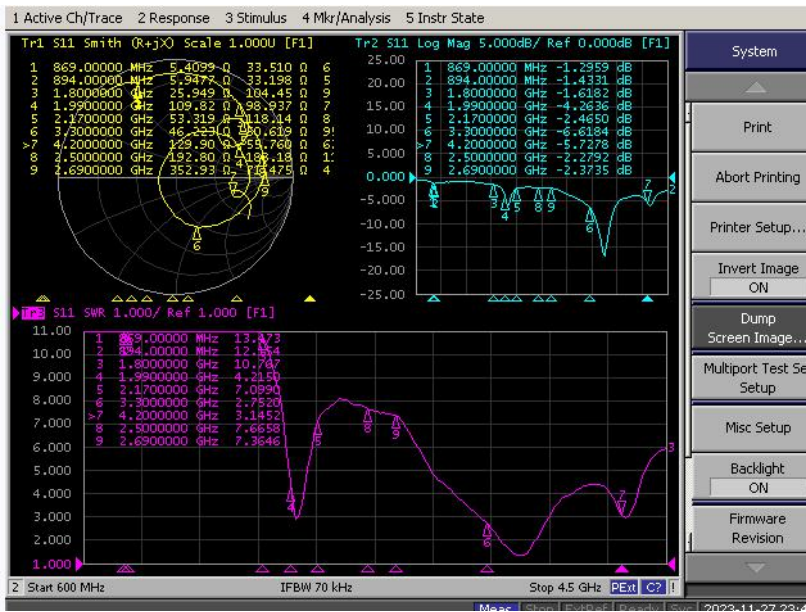

ANT5



Confidential Information

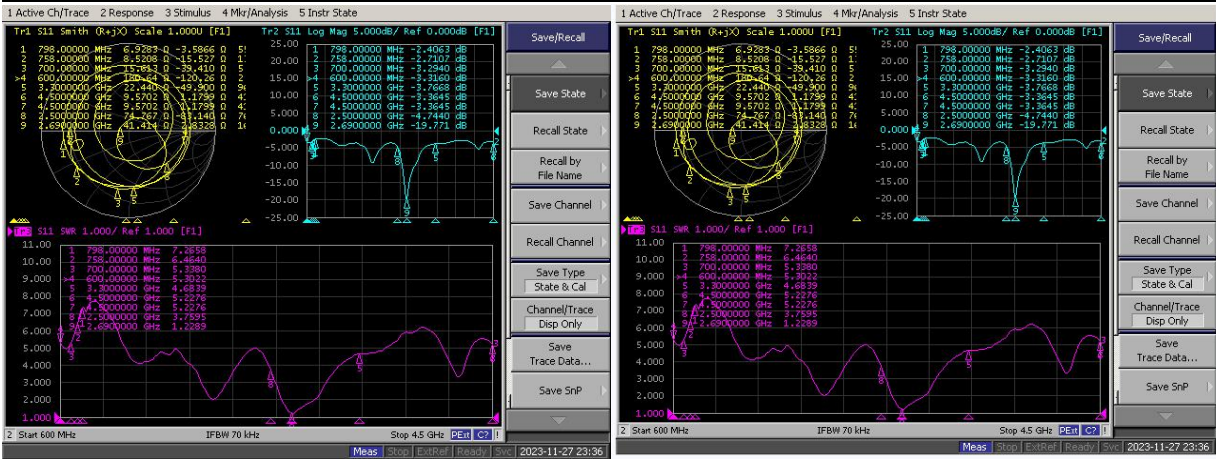

ANT7

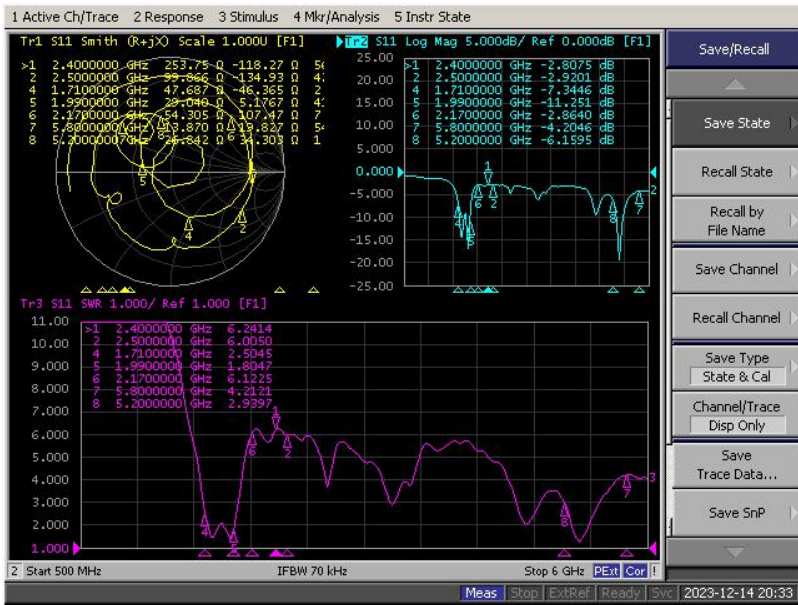

ANT8

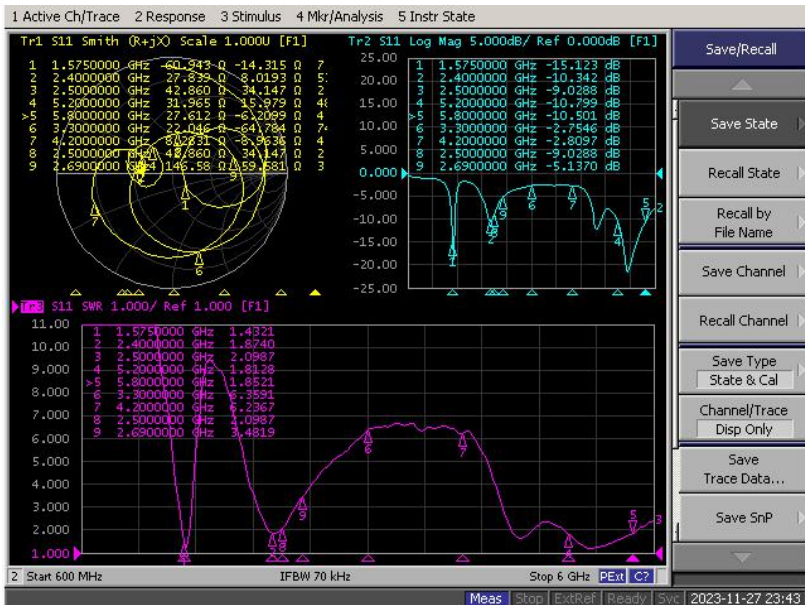

ANT9



ANT10



2.2 Efficiency & Gain

ANT1

Confidential Information

B5

B12

Freq (MHz)	Effi (%)	Effi (dB)	Gain (dBi)
800	20.08	-6.97	-3.25
810	22.7	-6.44	-2.98
820	23.82	-6.23	-2.85
830	23.27	-6.33	-2.85
840	22.27	-6.52	-2.89
850	20.32	-6.92	-3.18
860	19.47	-7.11	-3.43
870	18.04	-7.44	-3.82
880	17.84	-7.49	-3.99
890	16.62	-7.79	-4.3
900	15.37	-8.13	-4.73

Freq (MHz)	Effi (%)	Effi (dB)	Gain (dBi)
690	22.95	-6.39	-2.52
700	26.53	-5.76	-2.01
710	33.71	-4.72	-1.01
720	32.5	-4.88	-1.38
730	29.94	-5.24	-1.49
740	29.46	-5.31	-1.86
750	26.6	-5.75	-2.16
760	25.18	-5.99	-2.66
770	19.3	-7.14	-4.05
780	18.17	-7.41	-4.52
790	17.83	-7.49	-4.72

B13

B71

Freq (MHz)	Effi (%)	Effi (dB)	Gain (dBi)
740	27.51	-5.6	-2.15
750	30	-5.23	-1.58
760	30.9	-5.1	-1.89
770	24.87	-6.04	-3.03
780	23.51	-6.29	-3.38
790	24.64	-6.08	-3.19
800	28.36	-5.47	-2.66

Freq (MHz)	Effi (%)	Effi (dB)	Gain (dBi)
600	5.02	-13	-10.74
610	4.55	-13.42	-11.32
620	5	-13.01	-10.43
630	5.99	-12.23	-9.3
640	7.09	-11.49	-8.53
650	9.02	-10.45	-7.72
660	11.26	-9.48	-6.8
670	14.36	-8.43	-5.01
680	18.06	-7.43	-3.74
690	21.29	-6.72	-3.09
700	22.78	-6.42	-3.03

Confidential Information

Passive Test For 中高频							
Freq (MHz)	Effi (%)	Effi (dB)	Gain (dBi)	Gain	UHS	DHS	Max
				Gain	Effi (%)	Effi (dB)	Gain (dBi)
1710	7.35	-11.34	-8.62				
1720	8.28	-10.82	-7.94	2200	12.93	-8.88	-4.43
1730	9.35	-10.29	-7.33	2210	12.92	-8.89	-4.48
1740	10.15	-9.94	-6.85	2220	12.62	-8.99	-4.57
1750	10.56	-9.76	-6.58	2230	11.85	-9.26	-4.89
1760	12.11	-9.17	-5.65	2240	11.76	-9.3	-4.97
1770	13.42	-8.72	-4.92	2250	12.04	-9.19	-4.9
1780	16.07	-7.94	-3.94	2260	11.61	-9.35	-5.08
1790	17.79	-7.5	-3.37	2270	12.26	-9.12	-4.83
1800	18.72	-7.28	-2.93	2280	11.47	-9.41	-5.1
1810	19.1	-7.19	-2.83	2290	10.88	-9.63	-5.28
1820	19.37	-7.13	-2.53	2300	10.64	-9.73	-5.38
1830	19.21	-7.16	-2.67	2310	10.49	-9.79	-5.48
1840	18.73	-7.28	-2.71	2320	10.49	-9.79	-5.57
1850	18.09	-7.43	-3.15	2330	11.29	-9.47	-5.43
1860	16.93	-7.71	-3.47	2340	10.9	-9.63	-5.57
1870	16.19	-7.91	-3.87	2350	11.51	-9.39	-5.42
1880	16.22	-7.9	-4.04	2360	11.05	-9.57	-5.54
1890	17.01	-7.69	-4.1	2370	11.01	-9.58	-5.68
1900	18.54	-7.32	-4.09	2380	11.49	-9.4	-5.52
1910	21.07	-6.76	-4.06	2390	12.27	-9.11	-5.38
1920	23.54	-6.28	-3.56	2400	12.25	-9.12	-5.54
1930	24.44	-6.12	-3.34	2410	12.66	-8.97	-5.42
1940	24.38	-6.13	-3.47	2420	12.17	-9.15	-5.57
1950	24.44	-6.12	-3.31	2430	11.93	-9.24	-5.46
1960	23.81	-6.23	-3.23	2440	12.56	-9.01	-5.03
1970	24.14	-6.17	-2.83	2450	12.69	-8.96	-4.82
1980	23.88	-6.22	-2.56	2460	12.53	-9.02	-4.66
1990	22.63	-6.45	-2.44	2470	11.62	-9.35	-4.85
2000	21.99	-6.58	-2.25	2480	11.26	-9.49	-4.75
2010	19.98	-6.99	-2.39	2490	11.18	-9.51	-4.69
2020	18.74	-7.27	-2.53	2500	11.33	-9.46	-4.44
2030	18.1	-7.42	-2.69	2510	10.58	-9.75	-4.68
2040	16.56	-7.81	-3.26	2520	10.9	-9.62	-4.53
2050	15.58	-8.07	-4.07	2530	9.96	-10.02	-5.02
2060	14.76	-8.31	-5.07	2540	9.7	-10.13	-5.18
2070	14.51	-8.38	-4.85	2550	9.65	-10.16	-5.23
2080	15.46	-8.11	-4.46	2560	10.1	-9.96	-5
2090	15.84	-8	-4.28	2570	9.98	-10.01	-4.9
2100	15.64	-8.06	-4.24	2580	10.13	-9.94	-4.73
2110	13.51	-8.69	-4.85	2590	9.78	-10.09	-4.76
2120	12.77	-8.94	-5.02	2600	10.74	-9.69	-4.23
2130	13.17	-8.81	-4.68	2610	10.76	-9.68	-4.17
2140	13.57	-8.67	-4.46	2620	10.44	-9.81	-4.07
2150	12.97	-8.87	-4.45	2630	10.65	-9.73	-3.86
2160	12.71	-8.96	-4.42	2640	11.41	-9.43	-3.24
2170	12.22	-9.13	-4.57	2650	11.5	-9.39	-3.08
2180	11.96	-9.22	-4.66	2660	11.83	-9.27	-2.68
				2670	11.72	-9.31	-2.56
				2680	11.72	-9.31	-2.43
				2690	11.22	-9.5	-2.55
				2700	11	-9.59	-2.58

ANT2

Confidential Information

Passive Test For UHB				Passive Test For UHB			
Freq (MHz)	Effi (%)	Effi (dB)	Gain (dBi)	Freq (MHz)	Effi (%)	Effi (dB)	Gain (dBi)
3120	36.71	-4.35	-1.35	3720	39.8	-4	-0.52
3140	35.45	-4.5	-1.6	3740	37.57	-4.25	-0.97
3160	35.36	-4.51	-1.55	3760	35.8	-4.46	-1.26
3180	34.77	-4.59	-1.34	3780	31.6	-5	-1.88
3200	35.38	-4.51	-0.54	3800	33.58	-4.74	-1.72
3220	34.76	-4.59	-0.11	3820	32.67	-4.86	-2.11
3240	40.01	-3.98	0.94	3840	34.97	-4.56	-1.78
3260	38.51	-4.14	1.19	3860	37.31	-4.28	-1.65
3280	43.48	-3.62	1.93	3880	40.95	-3.88	-1.41
3300	39.3	-4.06	1.78	3900	43.51	-3.61	-1.06
3320	44.6	-3.51	2.36	3920	43.5	-3.61	-1.23
3340	40.77	-3.9	1.88	3940	48.22	-3.17	-0.9
3360	45.83	-3.39	2.14	3960	42.31	-3.74	-1.45
3380	42.89	-3.68	1.68	3980	46.39	-3.34	-1.09
3400	46.39	-3.34	1.89	4000	40.46	-3.93	-1.65
3420	44.1	-3.56	1.59	4020	40.16	-3.96	-1.57
3440	44.37	-3.53	1.47	4040	42.76	-3.69	-1.1
3460	39.09	-4.08	0.95	4060	43.12	-3.65	-1.19
3480	40.95	-3.88	1.07	4080	42.66	-3.7	-1.26
3500	37.12	-4.3	0.46	4100	43.55	-3.61	-1.35
3520	40.45	-3.93	0.54	4120	36.32	-4.4	-1.9
3540	38.93	-4.1	0.06	4140	39.34	-4.05	-1.32
3560	41.33	-3.84	-0.08	4160	34.42	-4.63	-1.85
3580	42.41	-3.73	-0.16	4180	29.96	-5.24	-2.31
3600	45.41	-3.43	0.14	4200	30.08	-5.22	-2.01
3620	43.43	-3.62	-0.08	4220	28.77	-5.41	-1.81
3640	46.88	-3.29	0.13	4240	25.74	-5.89	-2.19
3660	43.42	-3.62	-0.21	4260	25.3	-5.97	-2.16
3680	43.9	-3.58	-0.15	4280	22.97	-6.39	-2.52
3700	39.14	-4.07	-0.79	4300	22.73	-6.43	-2.69

ANT3

Confidential Information

Passive Test For 中高频				Passive Test For 中高频			
Freq (MHz)	Effi (%)	Effi (dB)	Gain (dBi)	Freq (MHz)	Effi (%)	Effi (dB)	Gain (dBi)
1710	29.64	-5.28	-0.41	2200	31.67	-4.99	-0.98
1720	32.44	-4.89	0.07	2210	30.84	-5.11	-0.94
1730	32.37	-4.9	0.08	2220	29.71	-5.27	-1.07
1740	31.96	-4.95	0.1	2230	27.89	-5.55	-1.28
1750	33.13	-4.8	0.31	2240	26.9	-5.7	-1.45
1760	34.26	-4.65	0.56	2250	26.73	-5.73	-1.53
1770	36.73	-4.35	0.89	2260	25.34	-5.96	-1.8
1780	37.2	-4.29	0.83	2270	26.21	-5.81	-1.82
1790	35.26	-4.53	0.62	2280	24.96	-6.03	-2.08
1800	34.21	-4.66	0.57	2290	23.7	-6.25	-2.31
1810	32.91	-4.83	0.56	2300	23.73	-6.25	-2.27
1820	31.26	-5.05	0.43	2310	23.93	-6.21	-2.21
1830	31.07	-5.08	0.48	2320	24.26	-6.15	-2.11
1840	30.91	-5.1	0.47	2330	26.6	-5.75	-1.58
1850	31.58	-5.01	0.54	2340	26.85	-5.71	-1.58
1860	32.78	-4.84	0.7	2350	27.77	-5.56	-1.34
1870	33.38	-4.77	0.78	2360	27.44	-5.62	-1.39
1880	34.08	-4.67	0.9	2370	26.95	-5.69	-1.28
1890	34.49	-4.62	1.01	2380	28.43	-5.46	-1.1
1900	34.84	-4.58	1.14	2390	30.19	-5.2	-0.77
1910	36.17	-4.42	1.35	2400	30.16	-5.21	-0.71
1920	37.68	-4.24	1.56	2410	29.91	-5.24	-0.68
1930	36.96	-4.32	1.37	2420	28.89	-5.39	-0.85
1940	35.93	-4.45	1.21	2430	27.59	-5.59	-1.04
1950	35.51	-4.5	1.15	2440	29.15	-5.35	-0.79
1960	35.31	-4.52	1.07	2450	29.45	-5.31	-0.71
1970	36.48	-4.38	1.04	2460	28.39	-5.47	-0.84
1980	37.76	-4.23	0.92	2470	26.66	-5.74	-1.14
1990	37.22	-4.29	0.63	2480	25.42	-5.95	-1.45
2000	38.35	-4.16	0.51	2490	24.85	-6.05	-1.69
2010	36.84	-4.34	0.19	2500	25.4	-5.95	-1.97
2020	36.25	-4.41	0.03	2510	23.9	-6.22	-2.41
2030	37.32	-4.28	0.19	2520	24.45	-6.12	-2.63
2040	36.85	-4.34	0.19	2530	23.11	-6.36	-3.18
2050	36.66	-4.36	0.11	2540	22.56	-6.47	-3.45
2060	36.38	-4.39	-0.07	2550	22.73	-6.43	-3.36
2070	35.93	-4.45	-0.37	2560	23.81	-6.23	-3.04
2080	37.21	-4.29	-0.52	2570	23.22	-6.34	-3.11
2090	37.73	-4.23	-0.74	2580	23.67	-6.26	-3.09
2100	37.31	-4.28	-0.7	2590	22.52	-6.47	-3.14
2110	32.23	-4.92	-1.21	2600	24.27	-6.15	-2.49
2120	30.8	-5.11	-1.32	2610	24	-6.2	-2.24
2130	31.75	-4.98	-0.99	2620	22.77	-6.43	-2.38
2140	32.71	-4.85	-0.76	2630	23.23	-6.34	-2.26
2150	31.73	-4.98	-0.75	2640	24.6	-6.09	-2.08
2160	31.18	-5.06	-0.72	2650	24.42	-6.12	-2.19
2170	30.6	-5.14	-0.87	2660	25.69	-5.9	-2.17
2180	30.11	-5.21	-1.06	2670	25.62	-5.91	-2.38
2190	32.22	-4.92	-0.96	2680	25.37	-5.96	-2.73
				2690	24.01	-6.2	-3.29
				2700	22.68	-6.44	-3.62

ANT4

Confidential Information

Passive Test For UHB				Passive Test For UHB			
Freq (MHz)	Effi (%)	Effi (dB)	Gain (dBi)	Freq (MHz)	Effi (%)	Effi (dB)	Gain (dBi)
3120	7.35	-11.34	-6.23	3720	37.8	-4.22	-0.43
3140	8.05	-10.94	-5.86	3740	33.9	-4.7	-0.83
3160	8.69	-10.61	-5.54	3760	37.14	-4.3	-0.32
3180	10.03	-9.99	-5.1	3780	31.33	-5.04	-1.2
3200	11.27	-9.48	-4.76	3800	32.57	-4.87	-0.86
3220	11.42	-9.42	-5.07	3820	30.08	-5.22	-1.12
3240	14.33	-8.44	-4.25	3840	27.58	-5.59	-1.42
3260	14.29	-8.45	-4.3	3860	26.95	-5.69	-1.62
3280	16.87	-7.73	-3.4	3880	27.91	-5.54	-1.35
3300	17.05	-7.68	-3.05	3900	27.79	-5.56	-1.24
3320	19.88	-7.02	-2.23	3920	28.76	-5.41	-0.87
3340	20.32	-6.92	-1.99	3940	28.45	-5.46	-0.68
3360	23.33	-6.32	-1.25	3960	27.98	-5.53	-0.65
3380	20.98	-6.78	-1.7	3980	29.7	-5.27	-0.23
3400	24.91	-6.04	-0.89	4000	25.05	-6.01	-1.1
3420	23.19	-6.35	-1.28	4020	27.24	-5.65	-0.59
3440	24.44	-6.12	-1.51	4040	23.47	-6.29	-1.37
3460	25.09	-6	-1.7	4060	22.29	-6.52	-1.89
3480	27.6	-5.59	-1.27	4080	21.17	-6.74	-2.48
3500	27.28	-5.64	-1.39	4100	18.54	-7.32	-3.29
3520	33.29	-4.78	-0.46	4120	17.53	-7.56	-3.11
3540	32.9	-4.83	-0.43	4140	17.7	-7.52	-2.88
3560	37.94	-4.21	0.07	4160	15.96	-7.97	-3.34
3580	37.07	-4.31	-0.16	4180	17.6	-7.55	-2.91
3600	40.44	-3.93	0.31	4200	17.4	-7.59	-3.03
3620	37.41	-4.27	-0.07	4220	19.47	-7.11	-2.3
3640	40.29	-3.95	0.33	4240	19.45	-7.11	-2.01
3660	37.58	-4.25	-0.16	4260	19.6	-7.08	-2.04
3680	35.91	-4.45	-0.25	4280	21.39	-6.7	-1.8
3700	34.87	-4.58	-0.57	4300	21.16	-6.75	-2.24

ANT5

Freq (MHz)	Effi (%)	Effi (dB)	Gain (dBi)	Freq (MHz)	Effi (%)	Effi (dB)	Gain (dBi)
800	7.68	-11.14	-8.36	700	3.75	-14.25	-10.78
810	8.27	-10.82	-7.42	710	4.21	-13.76	-10.3
820	9.32	-10.3	-6.65	720	3.49	-14.57	-11.16
830	9.23	-10.35	-6.73	730	3.84	-14.15	-10.81
840	7.71	-11.13	-7.79	740	3.7	-14.32	-11.11
850	6.63	-11.79	-8.66	750	4.05	-13.92	-10.44
860	5.42	-12.66	-9.72	760	3.34	-14.77	-11.35
870	4.81	-13.18	-9.94	770	2.45	-16.11	-13.03
880	4.38	-13.58	-9.9	780	3.27	-14.86	-11.67
890	4.73	-13.25	-9.83	790	4.6	-13.37	-10.27
900	4.45	-13.52	-10.12	800	6.08	-12.16	-8.97

Confidential Information

Freq (MHz)	Effi (%)	Effi (dB)	Gain (dBi)	Freq (MHz)	Effi (%)	Effi (dB)	Gain (dBi)
690	15.01	-8.24	-4.39	600	3.05	-15.16	-12.29
700	14.21	-8.47	-4.92	610	2.6	-15.86	-12.57
710	15.78	-8.02	-4.31	620	2.93	-15.34	-12.12
720	13.19	-8.8	-5.34	630	3.64	-14.39	-11.39
730	10.3	-9.87	-6.31	640	4.8	-13.18	-10.26
740	9.68	-10.14	-6.63	650	6.23	-12.05	-8.32
750	8.82	-10.54	-7.24	660	8.65	-10.63	-6.57
760	7.83	-11.06	-7.69	670	11.1	-9.55	-5.59
770	8.12	-10.91	-7.72	680	12.57	-9.01	-5.17
780	8.54	-10.68	-7.33	690	12.65	-8.98	-5.3
790	7.84	-11.06	-7.98	700	12.05	-9.19	-5.68
800	9.6	-10.18	-6.82				

Passive Test For 中高频							
Freq (MHz)	Effi (%)	Effi (dB)	Gain (dBi)	Freq (MHz)	Effi (%)	Effi (dB)	Gain (dBi)
1710	12.85	-8.91	-3.11	2180	23.26	-6.33	-1.23
1720	13.73	-8.62	-2.93	2190	23.13	-6.36	-1.34
1730	13.51	-8.69	-2.96	2200	22.06	-6.56	-1.71
1740	13.21	-8.79	-3.08	2210	20.55	-6.87	-2.07
1750	14.69	-8.33	-2.7	2220	19.94	-7	-2.29
1760	15.07	-8.22	-2.7	2230	19.99	-6.99	-2.2
1770	15.57	-8.08	-2.93	2240	18.83	-7.25	-2.32
1780	15.71	-8.04	-3.34	2250	18.3	-7.37	-2.39
1790	15.48	-8.1	-3.66	2260	17.97	-7.46	-2.51
1800	15.64	-8.06	-3.71	2270	17.98	-7.45	-2.51
1810	16.51	-7.82	-3.39	2280	17.96	-7.46	-2.63
1820	15.68	-8.05	-3.76	2290	17.6	-7.54	-2.7
1830	16.21	-7.9	-3.69	2300	18.59	-7.31	-2.43
1840	16.46	-7.84	-3.6	2310	19.26	-7.15	-2.3
1850	17.8	-7.5	-3.18	2320	20.66	-6.85	-1.96
1860	21.08	-6.76	-2.55	2330	23.14	-6.36	-1.66
1870	23.03	-6.38	-2.4	2340	26.15	-5.82	-1.16
1880	24.79	-6.06	-2.34	2350	26.54	-5.76	-1.22
1890	26.61	-5.75	-2.22	2360	28.14	-5.51	-1.04
1900	29.13	-5.36	-1.94	2370	27.87	-5.55	-0.96
1910	32.01	-4.95	-1.55	2380	29.26	-5.34	-0.86
1920	34.82	-4.58	-1.2	2390	29.54	-5.3	-0.82
1930	34.48	-4.62	-1.57	2400	29.42	-5.31	-1.06
1940	33.24	-4.78	-2.09	2410	27.26	-5.65	-1.44
1950	33.26	-4.78	-2.09	2420	26.34	-5.79	-1.86
1960	32.22	-4.92	-2.03	2430	24.31	-6.14	-2.24
1970	31.09	-5.07	-2.2	2440	22	-6.58	-2.59
1980	29.95	-5.24	-2.11	2450	20.96	-6.79	-3.19
1990	25.89	-5.87	-2.42	2460	19.31	-7.14	-3.87
2000	22.54	-6.47	-2.82	2470	17.92	-7.47	-4.04
2010	17.14	-7.66	-3.84	2480	17.53	-7.56	-4.02
2020	13.47	-8.7	-4.76	2490	17.87	-7.48	-3.77
2030	11.89	-9.25	-4.85	2500	16.93	-7.71	-3.82
2040	10.74	-9.69	-4.77	2510	16.41	-7.85	-3.79
2050	10.72	-9.7	-4.46	2520	15.43	-8.12	-4.19
2060	11.42	-9.42	-4.15	2530	16.98	-7.7	-3.89
2070	12.35	-9.08	-3.77	2540	17.47	-7.58	-3.78
2080	13.78	-8.61	-3.43	2550	19.31	-7.14	-3.48
2090	15.56	-8.08	-2.91	2560	20.33	-6.92	-3.32
2100	16.84	-7.74	-2.56	2570	22.44	-6.49	-2.89
2110	17.21	-7.64	-2.49	2580	21.79	-6.62	-3.09
2120	17.74	-7.51	-2.43	2590	22.4	-6.5	-3
2130	19.27	-7.15	-2.01	2600	22.69	-6.44	-2.84
2140	20.78	-6.82	-1.75	2610	22.59	-6.46	-2.66
2150	21.61	-6.65	-1.56	2620	21.02	-6.77	-2.85
2160	21.94	-6.59	-1.48	2630	20.15	-6.96	-2.8
2170	23.36	-6.32	-1.2	2640	20.7	-6.84	-2.5
				2650	20.96	-6.79	-2.33
				2660	21.17	-6.74	-2.16
				2670	21.5	-6.68	-2.02
				2680	22.96	-6.39	-1.71
				2690	22.81	-6.42	-1.74
				2700	23.54	-6.28	-1.68

Confidential Information

ANT7

Passive Test For 中高频				Passive Test For 中高频			
Freq (MHz)	Effi (%)	Effi (dB)	Gain (dBi)	Freq (MHz)	Effi (%)	Effi (dB)	Gain (dBi)
1710	22.48	-6.48	-2.87	2180	3.05	-15.16	-11.11
1720	26.26	-5.81	-2.25	2190	3.63	-14.4	-10.34
1730	29.11	-5.36	-2	2200	4.01	-13.97	-9.91
1740	30.9	-5.1	-1.71	2210	4.35	-13.61	-9.51
1750	31.81	-4.97	-1.55	2220	4.36	-13.61	-9.51
1760	33.95	-4.69	-1.21	2230	4.03	-13.95	-9.89
1770	35.99	-4.44	-0.95	2240	3.99	-13.99	-9.89
1780	36.01	-4.44	-1.04	2250	4.06	-13.91	-9.77
1790	33.37	-4.77	-1.44	2260	3.83	-14.16	-9.95
1800	31.59	-5	-1.79	2270	4.13	-13.84	-9.5
1810	30.34	-5.18	-2.11	2280	3.77	-14.24	-9.81
1820	28.12	-5.51	-2.56	2290	3.69	-14.33	-9.88
1830	27.19	-5.66	-2.81	2300	3.63	-14.4	-9.97
1840	25.7	-5.9	-3.16	2310	3.69	-14.33	-9.9
1850	25.28	-5.97	-3.36	2320	3.79	-14.21	-9.85
1860	26.59	-5.75	-3.12	2330	4.07	-13.9	-9.71
1870	26.62	-5.75	-3.09	2340	3.91	-14.08	-9.88
1880	25.63	-5.91	-3.24	2350	4.37	-13.99	-9.28
1890	25.74	-5.89	-3.18	2360	4.28	-13.69	-9.65
1900	26.11	-5.83	-3.06	2370	4.57	-13.4	-9.51
1910	26.29	-5.8	-2.94	2380	4.96	-13.05	-9.09
1920	26.55	-5.76	-2.72	2390	5.43	-12.65	-8.66
1930	23.93	-6.21	-2.84	2400	5.55	-12.56	-8.52
1940	21.02	-6.77	-3.25	2410	6.05	-12.18	-8.09
1950	19.73	-7.05	-3.24	2420	5.98	-12.23	-8.08
1960	17.58	-7.55	-3.6	2430	6.32	-11.99	-7.65
1970	15.79	-8.01	-3.74	2440	6.89	-11.62	-7.12
1980	14.49	-8.39	-4.16	2450	7.18	-11.44	-6.9
1990	12.92	-8.89	-4.55	2460	7.51	-11.25	-6.74
2000	11.2	-9.51	-5.29	2470	7.08	-11.5	-6.92
2010	9.56	-10.19	-5.99	2480	7.12	-11.48	-6.94
2020	7.83	-11.06	-6.74	2490	7.23	-11.41	-6.92
2030	6.63	-11.78	-7.5	2500	7.32	-11.35	-6.87
2040	5.68	-12.46	-8.2	2510	6.82	-11.66	-7.29
2050	4.61	-13.36	-9.03	2520	7.1	-11.49	-7.16
2060	3.5	-14.56	-10.22	2530	6.3	-12.01	-7.92
2070	2.69	-15.7	-11.17	2540	6.12	-12.13	-8.24
2080	2.33	-16.33	-11.99	2550	5.85	-12.33	-8.58
2090	2.04	-16.9	-12.26	2560	5.96	-12.24	-8.49
2100	1.92	-17.17	-12.48	2570	5.85	-12.33	-8.36
2110	1.61	-17.94	-13.26	2580	5.81	-12.36	-7.86
2120	1.64	-17.85	-13.44	2590	5.46	-12.62	-7.71
2130	1.97	-17.05	-12.66	2600	5.86	-12.32	-6.96
2140	2.34	-16.3	-12.23	2610	5.28	-12.77	-7.14
2150	2.54	-15.95	-11.95	2620	4.6	-13.37	-7.48
2160	2.81	-15.51	-11.54	2630	4.21	-13.76	-8.26
2170	2.79	-15.54	-11.59	2640	4.25	-13.71	-8.53
				2650	4.25	-13.71	-9.59
				2660	4.61	-13.36	-9.32
				2670	4.85	-13.14	-9.06
				2680	5.38	-12.69	-8.59
				2690	5.27	-12.78	-8.65
				2700	5.27	-12.78	-8.64

ANT8

Passive Test For GPS			
Freq (MHz)	Effi (%)	Effi (dB)	Gain (dBi)
1550	33.61	-4.73	1.15
1555	34.7	-4.6	1.26
1560	35.95	-4.44	1.39
1565	37.29	-4.28	1.49
1570	37.46	-4.26	1.43
1575	36.88	-4.33	1.29
1580	36.3	-4.4	1.17
1585	34.63	-4.61	0.83
1590	33.59	-4.74	0.55
1595	33.51	-4.75	0.42
1600	30.29	-5.19	-0.13

Confidential Information

ANT9

Passive Test For WIFI5.8							
Freq (MHz)	Effi (%)	Effi (dB)	Gain (dBi)	Freq (MHz)	Effi (%)	Effi (dB)	Gain (dBi)
5150	12.56	-9.01	-3.53	5500	27.25	-5.65	-1.33
5160	13	-8.86	-3.39	5510	26.13	-5.83	-1.52
5170	13.9	-8.57	-3.21	5520	26.22	-5.81	-1.55
5180	14.23	-8.47	-3.02	5530	27	-5.69	-1.5
5190	14.68	-8.33	-3.11	5540	27.92	-5.54	-1.35
5200	14.6	-8.36	-3.05	5550	26.66	-5.74	-1.48
5210	15.86	-8	-2.56	5560	25.08	-6.01	-1.45
5220	16.34	-7.87	-2.4	5570	25.46	-5.94	-1.29
5230	17.84	-7.49	-1.93	5580	26.44	-5.78	-0.94
5240	16.95	-7.71	-1.81	5590	25.81	-5.88	-0.94
5250	16.46	-7.83	-1.89	5600	25.34	-5.96	-1.09
5260	16.96	-7.71	-1.63	5610	24.36	-6.13	-1.08
5270	17.26	-7.63	-1.48	5620	24.28	-6.15	-0.99
5280	17.77	-7.5	-1.15	5630	24.42	-6.12	-0.83
5290	18.41	-7.35	-0.71	5640	23.68	-6.26	-0.97
5300	17.75	-7.51	-0.86	5650	24.1	-6.18	-0.58
5310	17.34	-7.61	-0.87	5660	24.92	-6.03	-0.68
5320	18.74	-7.27	-0.71	5670	23.59	-6.27	-0.74
5330	18.52	-7.32	-0.69	5680	23.29	-6.33	-0.84
5340	20.31	-6.92	-0.49	5690	23.7	-6.25	-0.89
5350	21.23	-6.73	-0.48	5700	22.9	-6.4	-0.85
2400	27.68	-5.58	-1.87	5710	22.54	-6.47	-1.09
2410	27.94	-5.54	-1.7	5720	21.15	-6.75	-1.36
2420	28.78	-5.41	-1.5	5730	21.57	-6.66	-1.2
2430	29.33	-5.33	-1.34	5740	21.79	-6.62	-1.28
2440	29.5	-5.3	-1.32	5750	21.89	-6.6	-1.1
2450	30.06	-5.22	-1.27	5760	19.24	-7.16	-1.99
2460	29.94	-5.24	-1.33	5770	19.15	-7.18	-1.81
2470	28.76	-5.41	-1.6	5780	17.86	-7.48	-2.25
2480	28.85	-5.4	-1.64	5790	17.62	-7.54	-2.39
2490	29.65	-5.28	-1.49	5800	17.24	-7.63	-2.52
2500	28.62	-5.43	-1.61	5810	17.12	-7.66	-2.87
				5820	17.58	-7.55	-3.01
				5830	17.33	-7.61	-3.36
				5840	16.61	-7.8	-3.57
				5850	17.58	-7.55	-3.46

Passive Test For WIFI2.4			
Freq (MHz)	Effi (%)	Effi (dB)	Gain (dBi)
2400	27.68	-5.58	-1.87
2410	27.94	-5.54	-1.7
2420	28.78	-5.41	-1.5
2430	29.33	-5.33	-1.34
2440	29.5	-5.3	-1.32
2450	30.06	-5.22	-1.27
2460	29.94	-5.24	-1.33
2470	28.76	-5.41	-1.6
2480	28.85	-5.4	-1.64
2490	29.65	-5.28	-1.49
2500	28.62	-5.43	-1.61

ANT10

Confidential Information

Passive Test For UHB							
Freq (MHz)	Effi (%)	Effi (dB)	Gain (dBi)	Freq (MHz)	Effi (%)	Effi (dB)	Gain (dBi)
3120	12.73	-8.95	-4.86	3660	30.78	-5.12	-1.77
3140	12.68	-8.97	-4.59	3680	28.96	-5.38	-1.88
3160	12.51	-9.03	-4.86	3700	28.8	-5.41	-2.06
3180	14.1	-8.51	-4.88	3720	32.37	-4.9	-1.37
3200	14.25	-8.46	-5.01	3740	28.69	-5.42	-1.72
3220	13.24	-8.78	-5.68	3760	32.43	-4.89	-1.09
3240	16.9	-7.72	-4.68	3780	28.34	-5.48	-1.37
3260	15.91	-7.98	-5.04	3800	29.5	-5.3	-1.23
3280	18.97	-7.22	-4.21	3820	30.61	-5.14	-1.03
3300	19.31	-7.14	-4.11	3840	28.63	-5.43	-1.25
3320	22.22	-6.53	-3.43	3860	27.89	-5.55	-1.28
3340	22.63	-6.45	-3.22	3880	30.21	-5.2	-0.76
3360	25.75	-5.89	-2.34	3900	30.01	-5.23	-0.57
3380	24.45	-6.12	-2.18	3920	32.27	-4.91	-0.38
3400	30.92	-5.1	-0.91	3940	33.25	-4.78	-0.29
3420	28.17	-5.5	-1.12	3960	30.67	-5.13	-0.73
3440	29.92	-5.24	-1.07	3980	34.44	-4.63	-0.32
3460	28.32	-5.48	-1.65	4000	29.02	-5.37	-1.1
3480	28.91	-5.39	-1.71	4020	29.96	-5.23	-1.15
3500	26.92	-5.7	-2	4040	28.04	-5.52	-1.17
3520	31.03	-5.08	-1.56	4060	26.39	-5.78	-1.67
3540	30.73	-5.12	-1.86	4080	25.72	-5.9	-1.61
3560	33.93	-4.69	-1.66	4100	22.96	-6.39	-2.1
3580	30.11	-5.21	-2.4	4120	20.05	-6.98	-2.77
3600	33.17	-4.79	-2.26	4140	20.63	-6.86	-2.59
3620	29.48	-5.3	-2.65	4160	18.11	-7.42	-2.86
3640	31.74	-4.98	-2.03	4180	18.34	-7.37	-2.74
				4200	18.14	-7.41	-2.86
				4220	19.28	-7.15	-2.69
				4240	19.05	-7.2	-2.61
				4260	19.14	-7.18	-2.49
				4280	20.47	-6.89	-2.25
				4300	18.4	-7.35	-2.92

2.3 3D Pattern

ANT1

860.000MHz

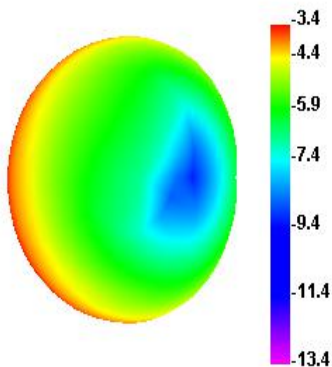

860.000MHz H

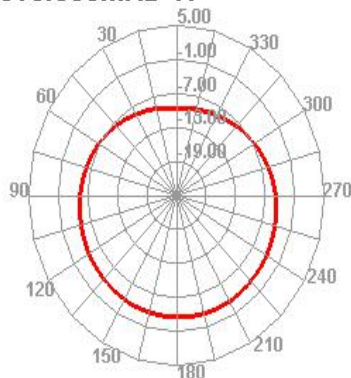

860.000MHz E2



860.000MHz E1

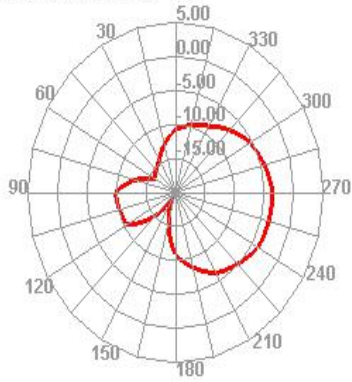

1800.000MHz

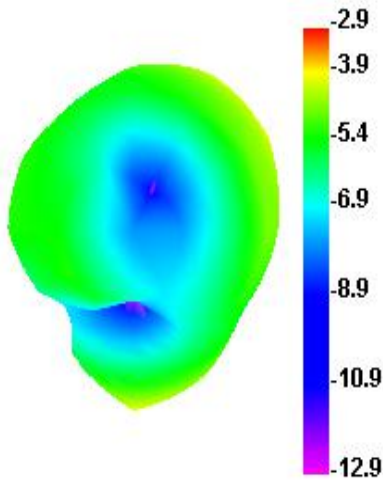

1800.000MHz H

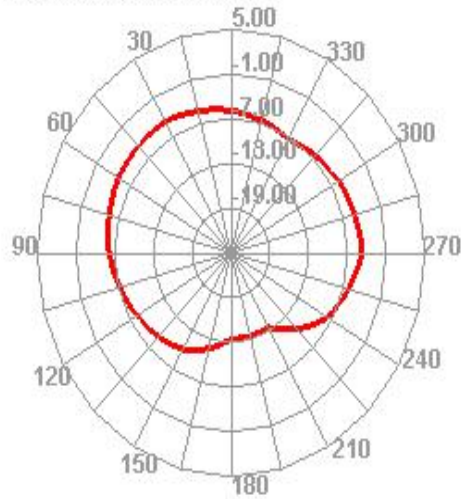

1800.000MHz E1

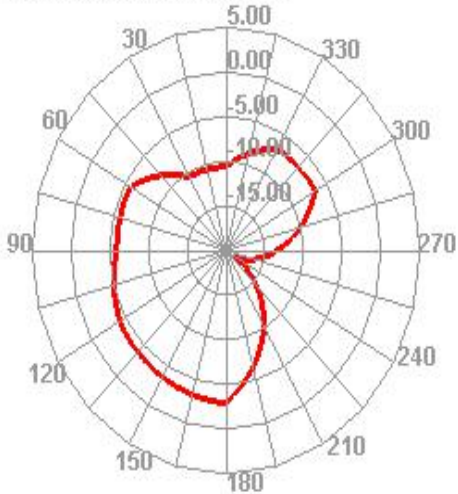

1800.000MHz E2

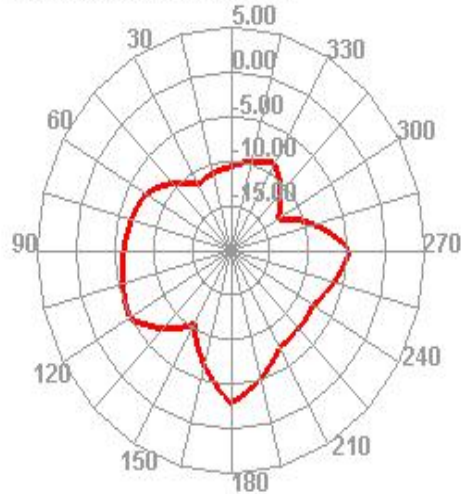

2170.000MHz

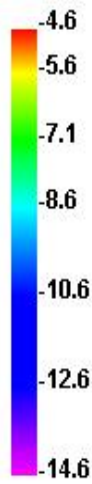
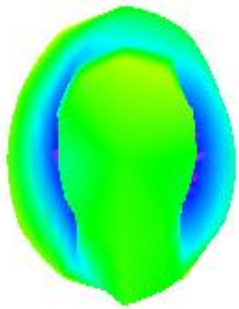

2170.000MHz H

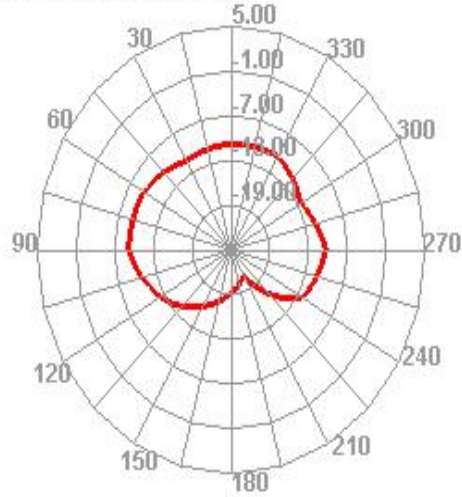

2170.000MHz E1

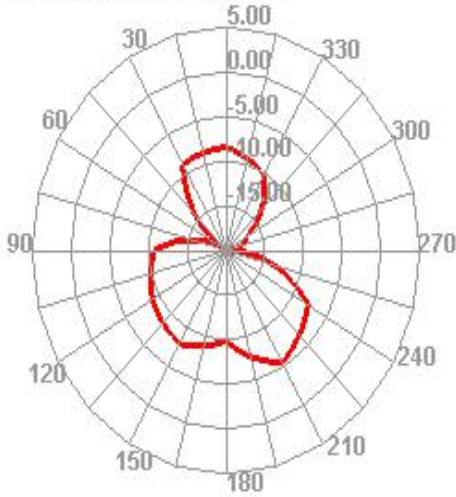

2170.000MHz E2

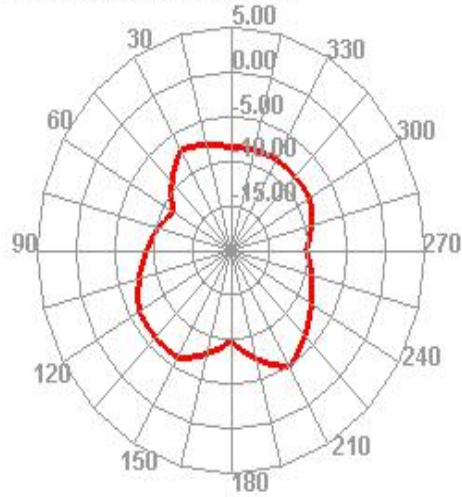

2500.000MHz

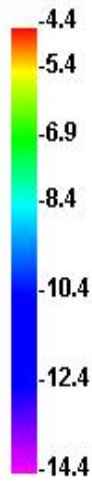
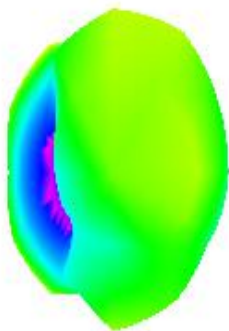

2500.000MHz H

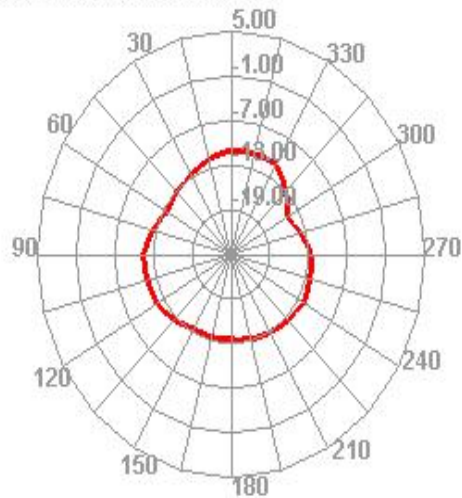

2690.000MHz

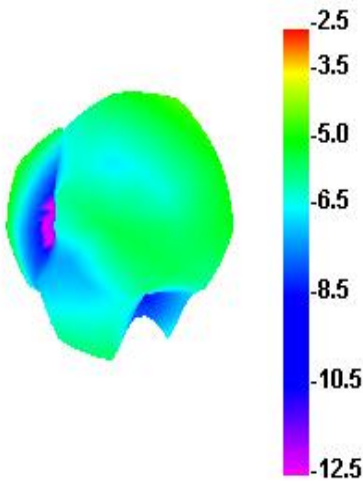

2690.000MHz H

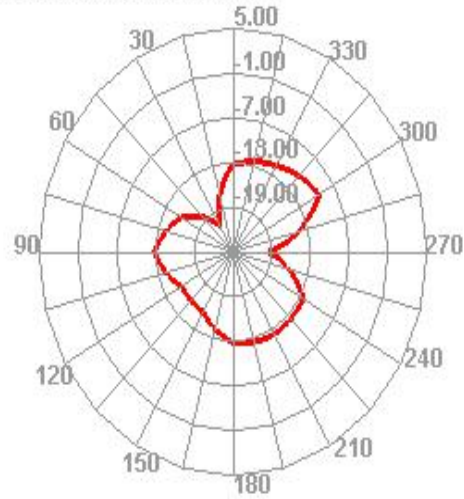

700.000MHz

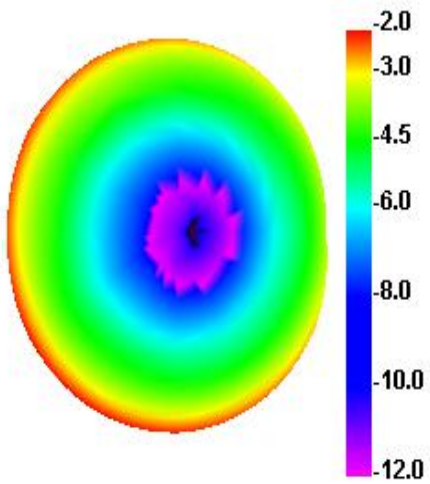

700.000MHz H

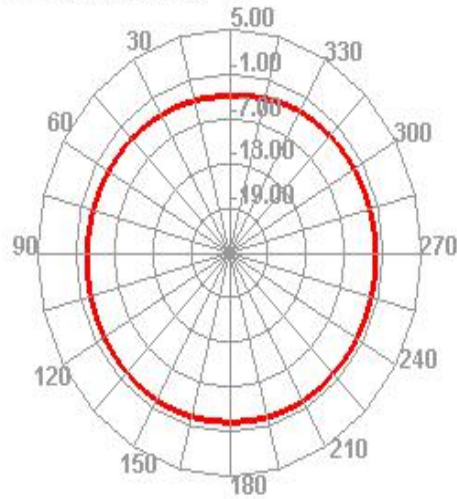

750.000MHz

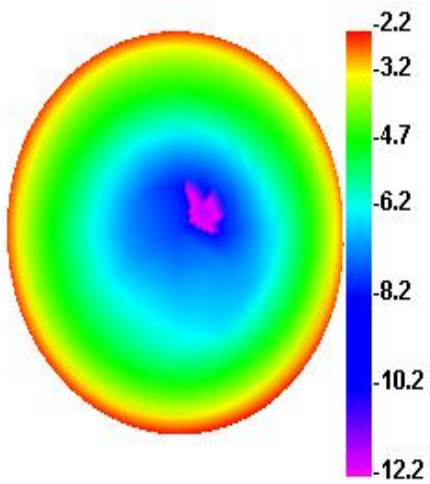

750.000MHz H

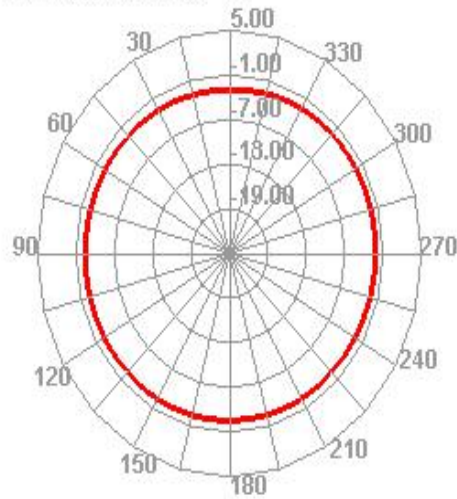

760.000MHz

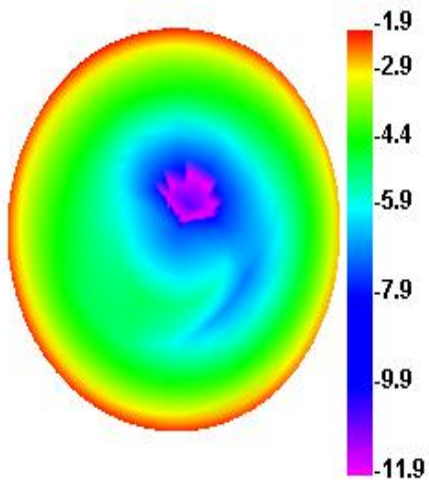

760.000MHz H

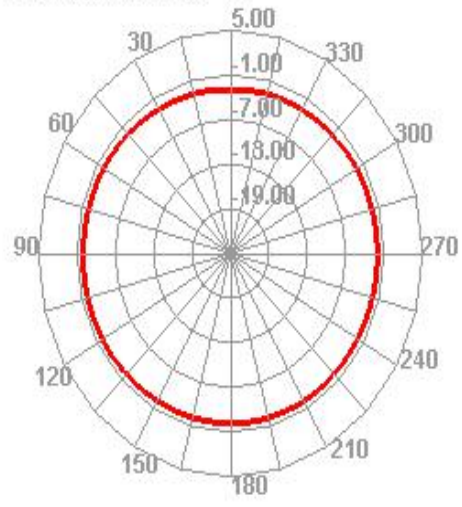

790.000MHz

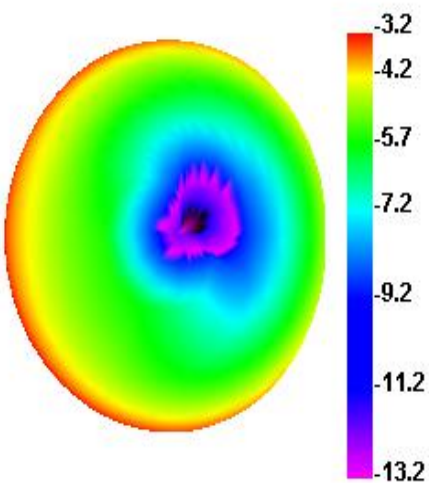

790.000MHz H

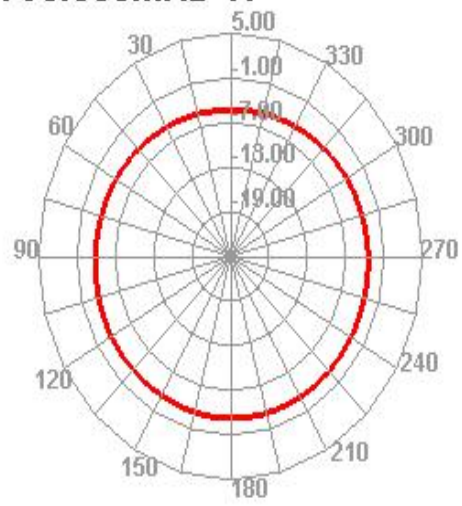

660.000MHz

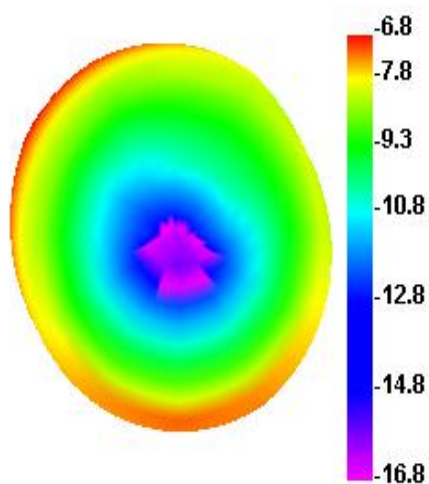

660.000MHz H

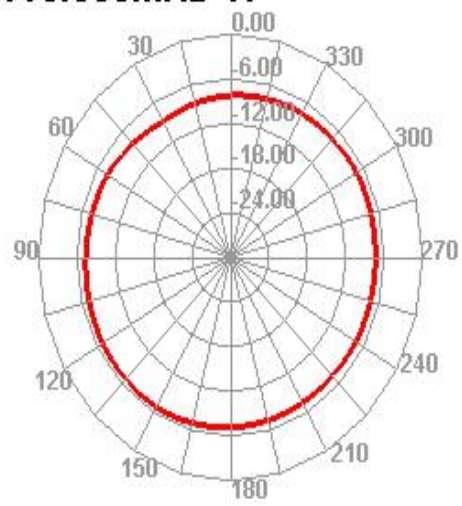

690.000MHz

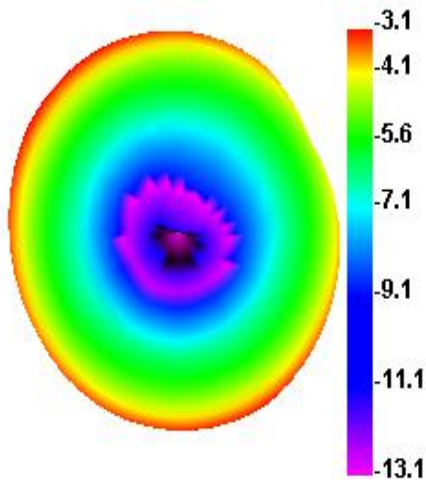

690.000MHz H

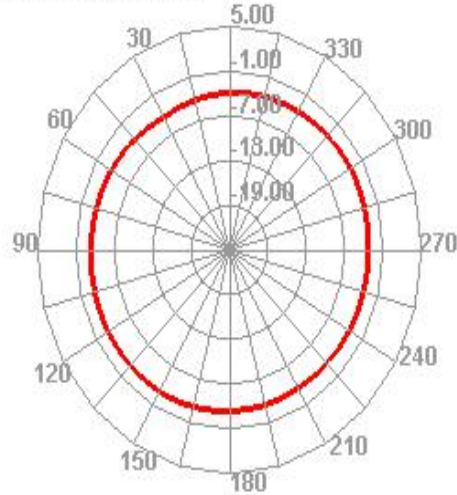

3300.000MHz

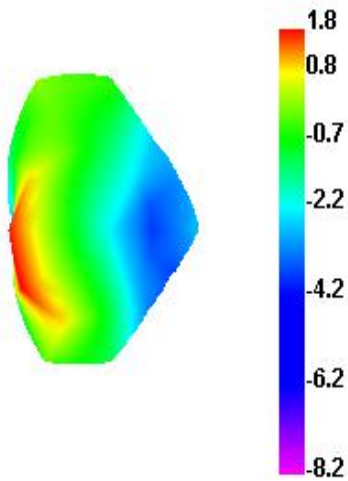

3300.000MHz H

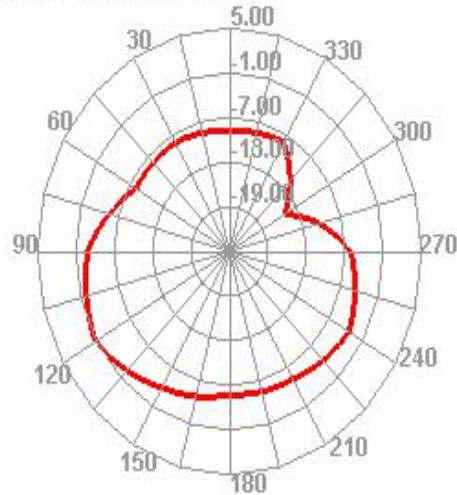

4300.000MHz

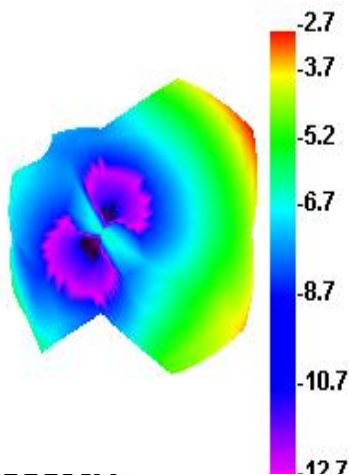

4300.000MHz H

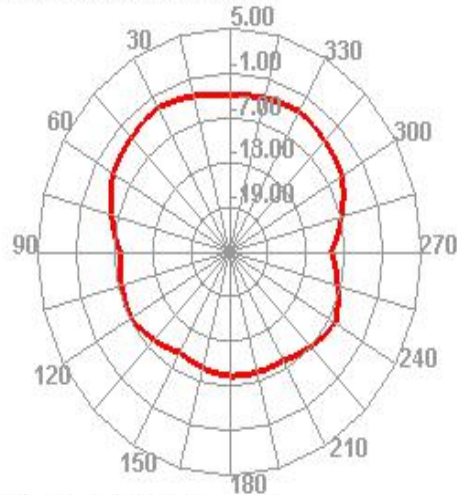

3120.000MHz

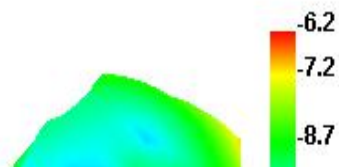

3120.000MHz H

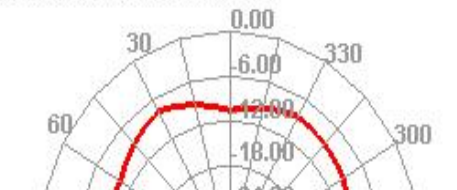

3500.000MHz

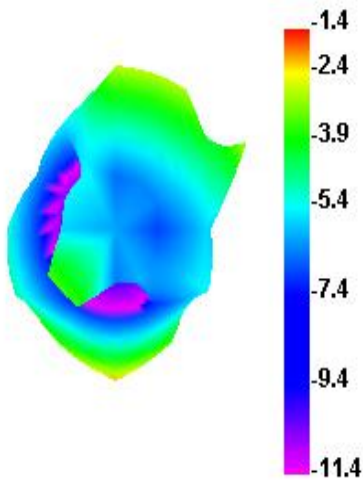

3500.000MHz H

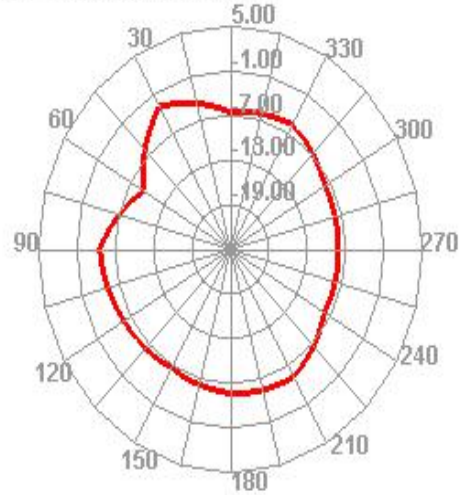

4300.000MHz

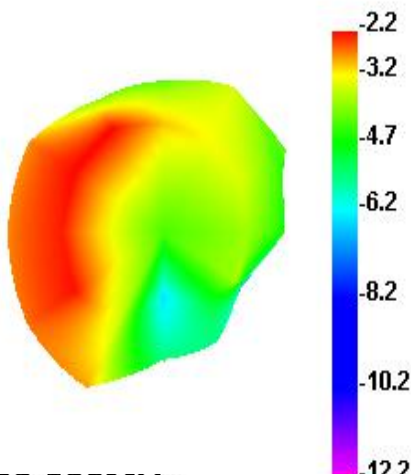

4300.000MHz H

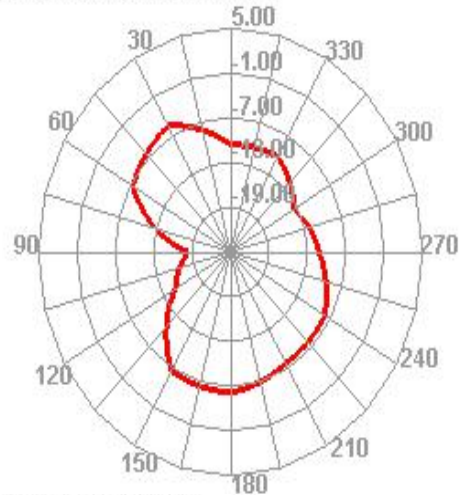

760.000MHz

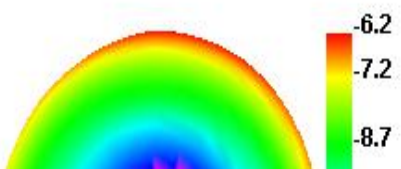

760.000MHz H



750.000MHz

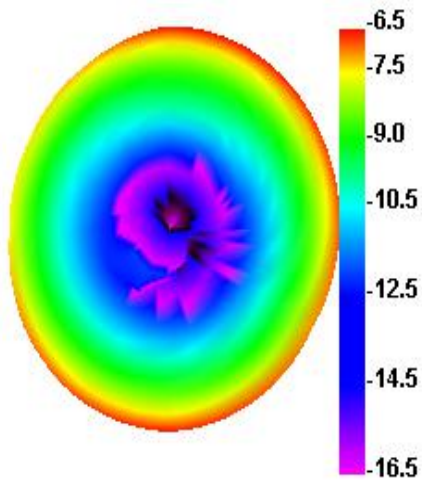

750.000MHz H

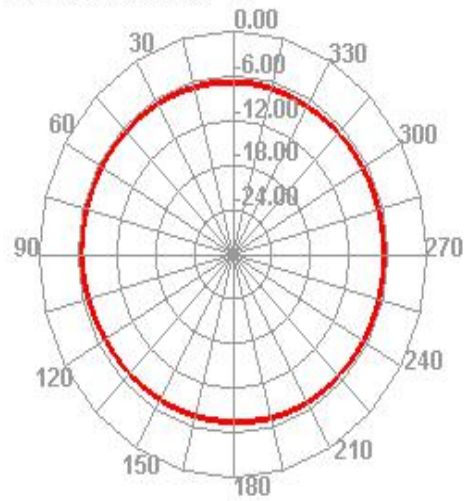

860.000MHz

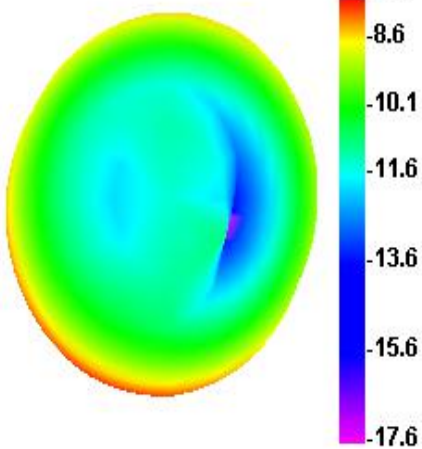

860.000MHz H

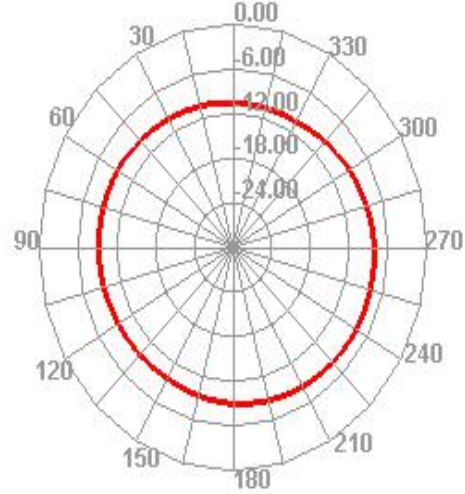

890.000MHz

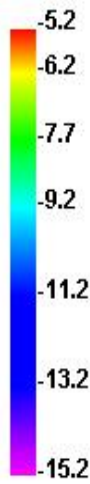
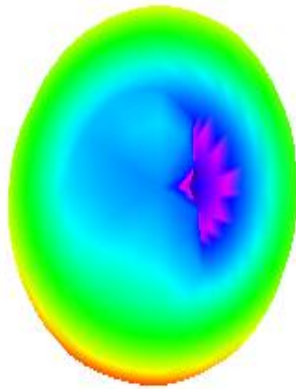

890.000MHz H

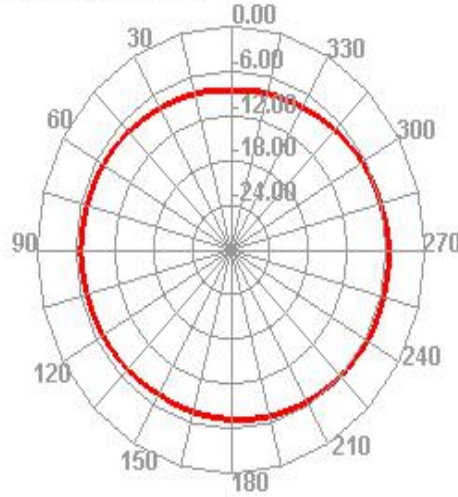

700.000MHz

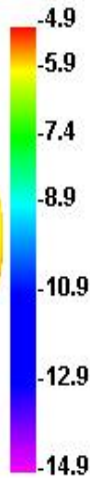
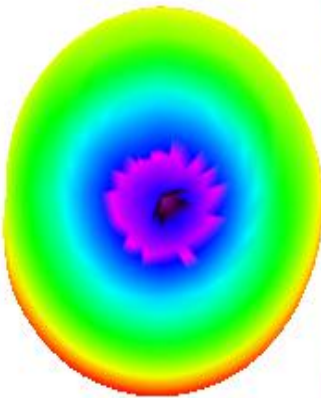

700.000MHz H

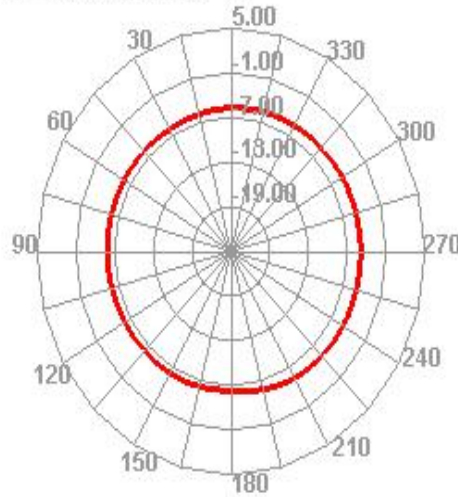

750.000MHz

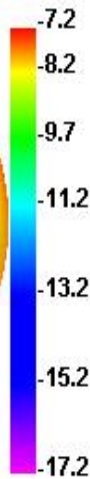
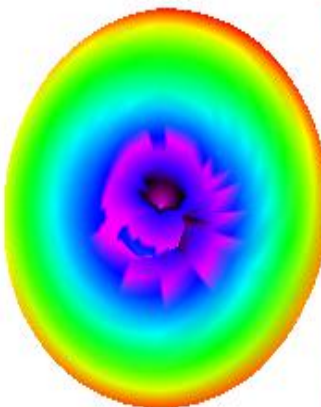

750.000MHz H

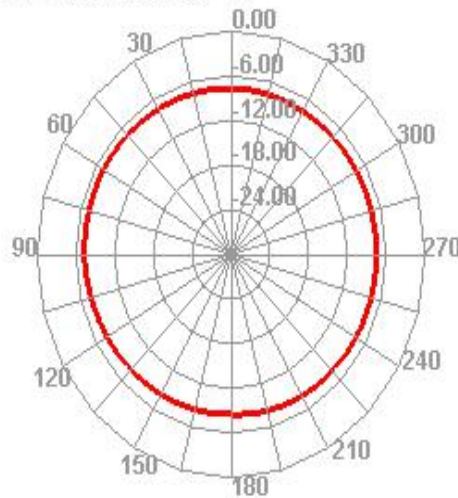

650.000MHz

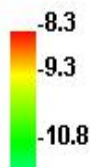
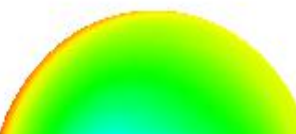

650.000MHz H



690.000MHz

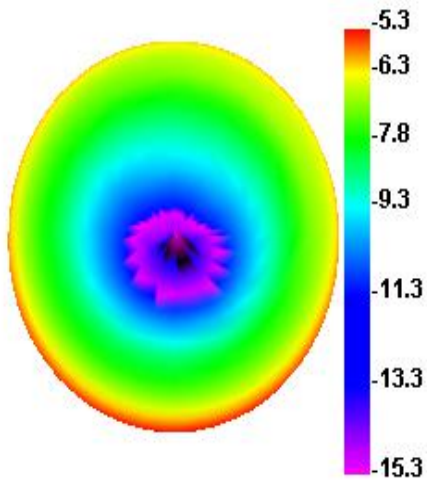

690.000MHz H

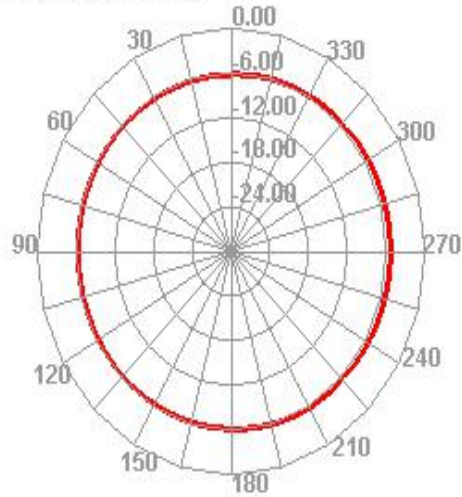

1710.000MHz

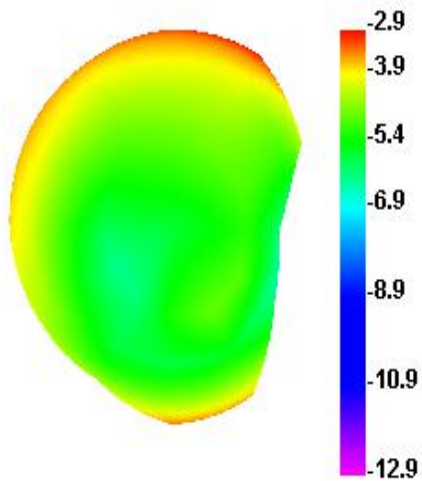

1710.000MHz H

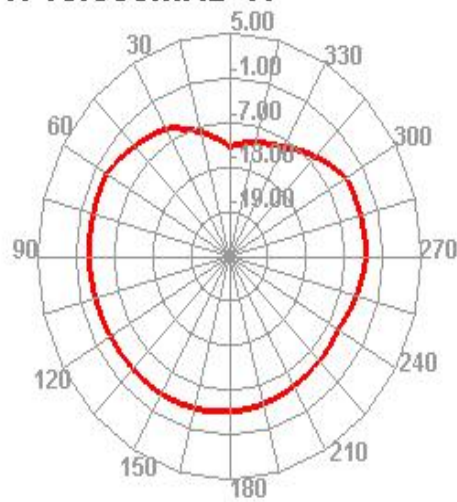

1880.000MHz

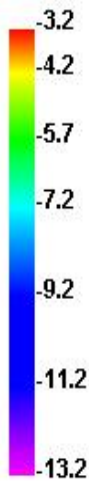
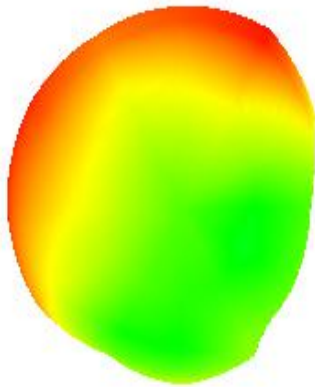

1880.000MHz H

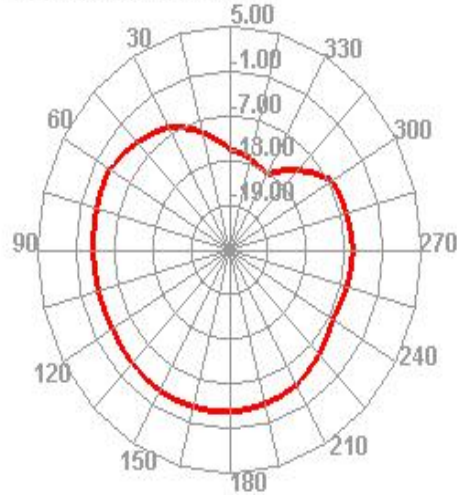

1990.000MHz

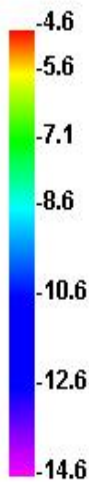
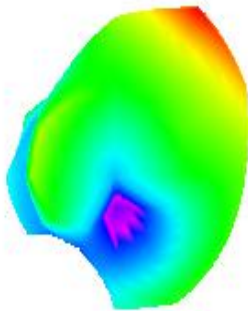

1990.000MHz H

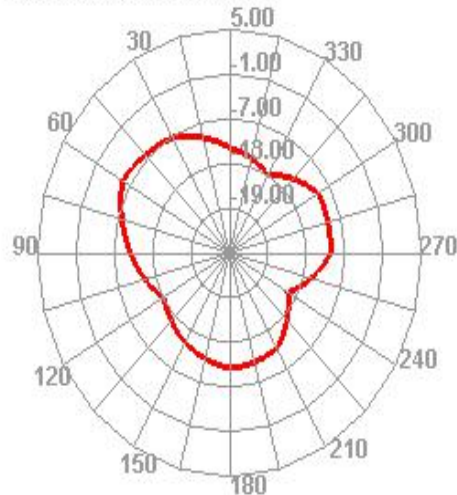

1575.000MHz

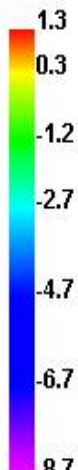
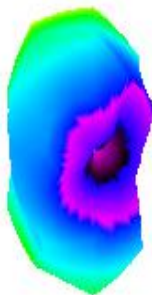

1575.000MHz H

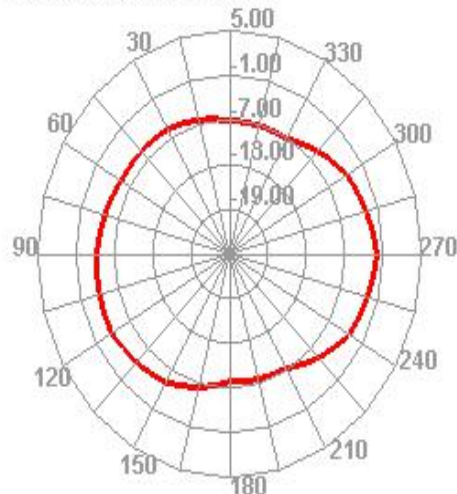

1600.000MHz

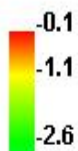
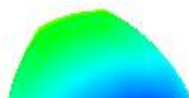

1600.000MHz H



2400.000MHz

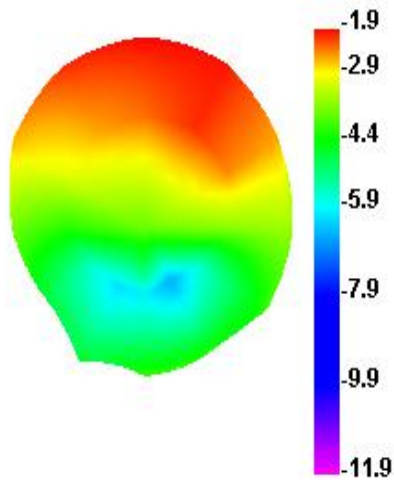

2400.000MHz H

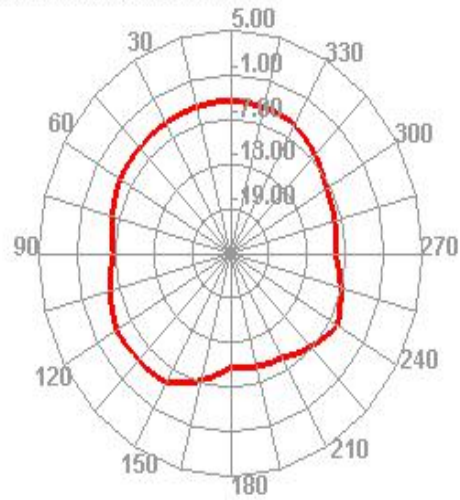

5200.000MHz

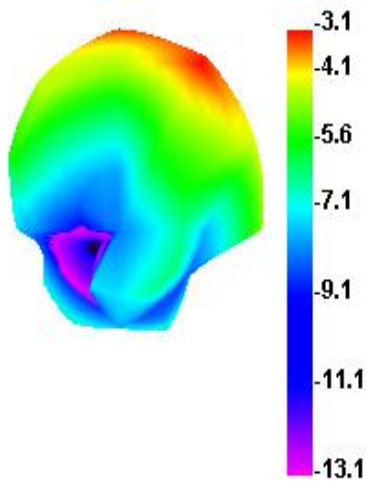

5200.000MHz H

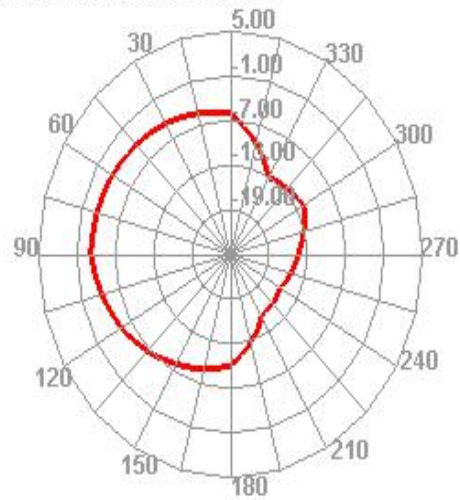

5800.000MHz

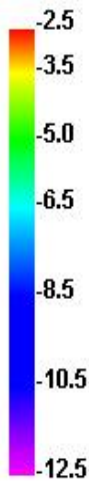
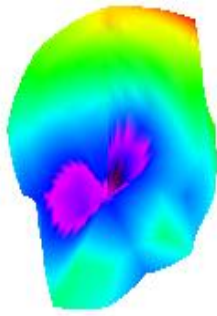

5800.000MHz H

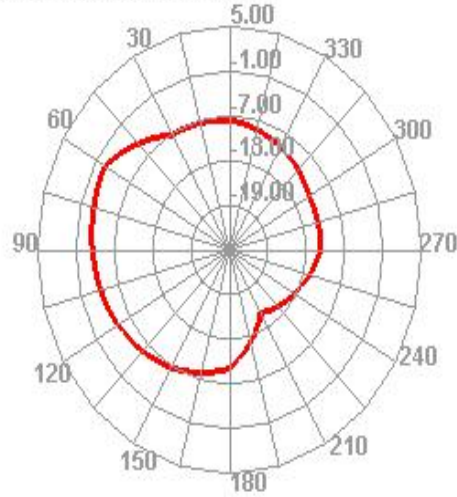

3300.000MHz

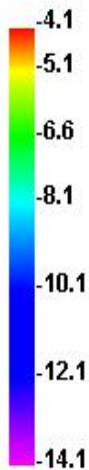
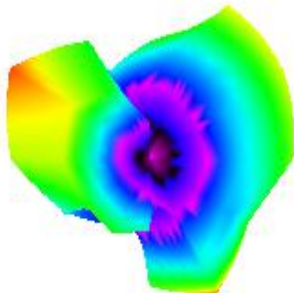

3300.000MHz H

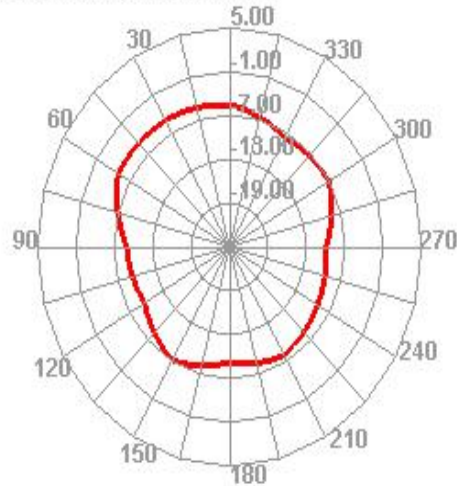

4200.000MHz

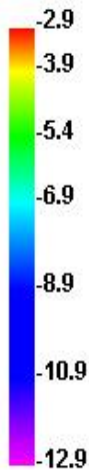
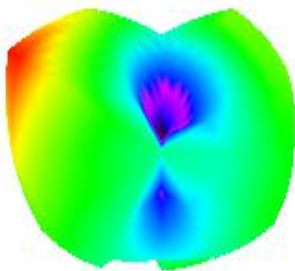

4200.000MHz H

