



# Hearing Aid Compatibility (HAC) Volume Control Test Report

**APPLICANT** : Reliance Communications LLC  
**PRODUCT NAME** : Orbic Trophy 5G  
**MODEL NAME** : R667L5  
**BRAND NAME** : Orbic  
**FCC ID** : 2ABGH-R667L5  
**STANDARD(S)** : FCC 47 CFR Part 20(20.19)  
ANSI C63.19-2019  
ANSI/TIA-5050-2018  
**RECEIPT DATE** : 2024-02-28  
**TEST DATE** : 2024-03-19 to 2024-04-01  
**ISSUE DATE** : 2024-05-06



Edited by: Xie Yiyun  
Xie Yiyun (Rapporteur)

Approved by: Gan Yueming  
Gan Yueming (Supervisor)

**NOTE:** This document is issued by Shenzhen Morlab Communications Technology Co., the test report shall not be reproduced except in full without prior written permission of the company. The test results apply only to the particular sample(s) tested and to the specific tests carried out which is available on request for validation and information confirmed at our website.





# DIRECTORY

|  |    |
|--|----|
| 1. Statement of Volume Control.....                        | 4  |
| 2. Technical Information .....                             | 5  |
| 2.1. Applicant and Manufacturer Information .....          | 5  |
| 2.2. Equipment under Test (EUT) Description.....           | 5  |
| 2.3. Applied Reference Documents .....                     | 7  |
| 3. Air Interface and Operating Mode .....                  | 8  |
| 4. Volume Control Test Requirements and Restrictions ..... | 9  |
| 4.1. Conversational Gain Performance .....                 | 9  |
| 4.2. Receive Distortion and Noise Performance.....         | 9  |
| 4.3. Receive Acoustic Frequency Response Performance ..... | 9  |
| 5. Volume Control Measurement System .....                 | 12 |
| 6. Volume Control Measurement Procedure .....              | 13 |
| 7. Test Equipment List .....                               | 14 |
| 8. Supported Codec Summary.....                            | 15 |
| 9. Test Results Summary.....                               | 17 |
| 9.1. General Guidance .....                                | 17 |
| 9.2. Test Results .....                                    | 18 |
| 10. Uncertainty Assessment .....                           | 25 |
| Annex A General Information.....                           | 27 |
| Annex B Test Setup Photos .....                            | 28 |
| Annex C Test Results Data of Distortion and Noise .....    | 28 |
| Annex D Test Results of Volume Control.....                | 28 |



REPORT No.: SZ23110216S02

| Change History |            |                   |
|----------------|------------|-------------------|
| Version        | Date       | Reason for change |
| 1.0            | 2024-05-06 | First edition     |
|                |            |                   |



# 1. Statement of Volume Control

The lowest conversational gain found during test as bellows:

| Mounting Force | Lowest Conversational Gain (dB) |
|----------------|---------------------------------|
| 2N             | 14.80                           |
| 8N             | 16.79                           |

**Note:**

1. This device is in compliance with compliance with HAC requirement specified in FCC 47 CFR Part 20.19 and ANSI C63.19-2019 and tested in accordance with the measurement methods and procedures specified in ANSI/TIA-5050-2018 and FCC KDB publications.
2. The 2N force is used for testing requirements related to use by persons with hearing devices and the 8N force is used for testing requirements related to use by persons without hearing devices.
3. When the test result is a critical value, we will use the measurement uncertainty give the judgment result based on the 95% confidence intervals.



## 2. Technical Information

**Note:** Provide by applicant.

### 2.1. Applicant and Manufacturer Information

|                              |   |
|------------------------------|---|
| <b>Applicant:</b>            | Reliance Communications LLC   |
| <b>Applicant Address:</b>    | 555 Wireless Blvd. Hauppauge, NY 11788, USA   |
| <b>Manufacturer:</b>         | Unimaxcomm  |
| <b>Manufacturer Address:</b> | 35F,HBC HuiLong Center Building-II Minzhi Street,Longhua, Shenzhen, P.R. China 518110 |

### 2.2. Equipment under Test (EUT) Description

|                          |   |
|--------------------------|---|
| <b>Product Name:</b>     | Orbic Trophy 5G   |
| <b>EUT IMEI:</b>         | 357564240004501   |
| <b>Hardware Version:</b> | V1.0  |
| <b>Software Version:</b> | R667L5_v1.0.4_BLB   |
| <b>Frequency Bands:</b>  | GSM 850: 824 MHz ~ 849 MHz<br>GSM 1900: 1850 MHz ~ 1910 MHz<br>WCDMA Band II: 1850 MHz ~ 1910 MHz<br>WCDMA Band IV: 1710 MHz ~ 1755 MHz<br>WCDMA Band V: 824 MHz ~ 849 MHz<br>LTE Band 2: 1850 MHz ~ 1910 MHz<br>LTE Band 4: 1710 MHz ~ 1755 MHz<br>LTE Band 5: 824 MHz ~ 849 MHz<br>LTE Band 7: 2500 MHz ~ 2570 MHz<br>LTE Band 12: 699 MHz ~ 716 MHz<br>LTE Band 13: 777 MHz ~ 787 MHz<br>LTE Band 17: 704 MHz ~ 716 MHz<br>LTE Band 25: 1850 MHz ~ 1915 MHz<br>LTE Band 66: 1710 MHz ~ 1780 MHz<br>LTE Band 71: 663 MHz ~ 698 MHz<br>5G NR n2 (NSA): 1850 MHz ~ 1910 MHz<br>5G NR n5 (NSA): 824 MHz ~ 849 MHz<br>5G NR n66 (NSA): 1710 MHz ~ 1780 MHz<br>5G NR n77 (NSA): 3450 MHz ~ 3550 MHz; 3700 MHz ~ 3980 MHz<br>WLAN 2.4GHz: 2412 MHz ~ 2462 MHz<br>WLAN 5.2GHz: 5180 MHz ~ 5240 MHz<br>WLAN 5.3GHz: 5260 MHz ~ 5320 MHz |



|                               |   |                      |
|-------------------------------|---|----------------------|
|                               | WLAN 5.5GHz: 5500 MHz ~ 5720 MHz<br>WLAN 5.8GHz: 5745 MHz ~ 5825 MHz<br>Bluetooth: 2402 MHz ~ 2480 MHz<br>NFC: 13.56 MHz  |                      |
| <b>Modulation Mode:</b>       | GSM/GPRS: GMSK<br>EDGE: 8PSK<br>WCDMA: QPSK, 16QAM<br>LTE: QPSK, 16QAM, 64QAM<br>5G NR: DFT-s-OFDM/CP-OFDM, PI/2 BPSK<br>QPSK, 16QAM, 64QAM, 256QAM<br>802.11b: DSSS<br>802.11a/g/n-HT20/HT40/ac-VHT20/40/80: OFDM<br>BR+EDR: GFSK(1Mbps), $\pi/4$ -DQPSK(2Mbps), 8-DPSK(3Mbps)<br>Bluetooth LE: GFSK(1Mbps, 2Mbps)<br>NFC: ASK |                      |
| <b>Antenna type:</b>          | WWAN: PIFA Antenna<br>WLAN: PIFA Antenna<br>Bluetooth: PIFA Antenna<br>NFC: Loop Antenna  |                      |
| <b>VoLTE Mode:</b>            | Support   |                      |
| <b>VoWi-Fi Mode:</b>          | Support   |                      |
| <b>SIM Cards Description:</b> | SIM 1   | GSM+WCDMA +LTE+5G NR |
|                               | SIM 2   | GSM+WCDMA +LTE+5G NR |
|                               | For dual SIM card version, both the SIM 1 and SIM 2 are the same chipset unit and tested as a single chipset, the SIM 1 was selected for testing.   |                      |

**Note:** For more detailed description, please refer to specification or user manual supplied by the applicant and/or manufacturer.



## 2.3. Applied Reference Documents

### Leading reference documents for testing:

| No. | Identity                   | Document Title  | Method determination<br>Remark |
|-----|----------------------------|---|--------------------------------|
| 1   | FCC 47 CFR Part 20 (20.19) | Hearing aid-compatible mobile handsets  | No deviation                   |
| 2   | ANSI C63.19-2019           | American National Standard Methods of Measurement of Compatibility between Wireless Communications Devices and Hearing Aids | No deviation                   |
| 3   | ANSI/TIA-5050-2018         | Telecommunications Communications Products Receive Volume Control Requirements for Wireless (Mobile) Devices                | No deviation                   |
| 4   | KDB 285076 D01v06r04       | HAC Guidance  | No deviation                   |
| 5   | KDB 285076 D03v01r06       | HAC FAQ   | No deviation                   |
| 6   | KDB 285076 D04v02          | Volume Control  | No deviation                   |
| 7   | KDB 285076 D05v01          | HAC Waiver DA 23-914  | No deviation                   |

**Note:** Additions to, deviation, or exclusions from the method shall be judged in the "method determination" column of add, deviate or exclude from the specific method shall be explained in the "Remark" of the above table.



### 3. Air Interface and Operating Mode

| Air Interface     | Band            | Transport Type | Volume Control Tested | Simultaneous Transmitter | Name of Voice Service | Power Reduction |
|-------------------|-----------------|----------------|-----------------------|--------------------------|-----------------------|-----------------|
| GSM               | GSM850          | VO             | Yes                   | WLAN,BT                  | CMRS Voice            | No              |
|                   | GSM1900         |                | Yes                   |                          |                       | No              |
| WCDMA (UMTS)      | Band II         | VO             | Yes                   | WLAN,BT                  | CMRS Voice            | No              |
|                   | Band IV         |                | Yes                   |                          |                       | No              |
|                   | Band V          |                | Yes                   |                          |                       | No              |
| FDD-LTE & TDD-LTE | Band 2          | VD             | Yes                   | WLAN,BT                  | VoLTE                 | No              |
|                   | Band 4          |                | Yes                   |                          |                       | No              |
|                   | Band 5          |                | Yes                   |                          |                       | No              |
|                   | Band 7          |                | Yes                   |                          |                       | No              |
|                   | Band 12         |                | Yes                   |                          |                       | No              |
|                   | Band 13         |                | Yes                   |                          |                       | No              |
|                   | Band 17         |                | Yes                   |                          |                       | No              |
|                   | Band 25         |                | Yes                   |                          |                       | No              |
|                   | Band 66         |                | Yes                   |                          |                       | No              |
| Band 71           | Yes             | No             |                       |                          |                       |                 |
| 5G NR             | n2 (NSA)        | DT             | No                    | WLAN, BT                 | N/A                   | No              |
|                   | n5 (NSA)        |                | No                    |                          |                       | No              |
|                   | n66 (NSA)       |                | No                    |                          |                       | No              |
|                   | n77 (NSA)       |                | No                    |                          |                       | No              |
| WiFi              | 2450            | VD             | Yes                   | GSM, UMTS, LTE, 5G NR    | VoWiFi                | No              |
|                   | 5200 (U-NII-1)  |                | Yes                   |                          |                       | No              |
|                   | 5300 (U-NII-2A) |                | Yes                   |                          |                       | No              |
|                   | 5500 (U-NII-2C) |                | Yes                   |                          |                       | No              |
|                   | 5800 (U-NII-3)  |                | Yes                   |                          |                       | No              |
| BT                | 2450            | DT             | No                    | GSM, UMTS, LTE, 5G NR    | N/A                   | No              |

**Where:**

VO=Voice Only

DT=Digital Transport only

VD=CMRS and IP Voice Service over Digital Transport

BT=Bluetooth

**Note:**

- 1) Air Interface/Band MHz:** List of all air interfaces and bands supported by the handset.
- 2) Simultaneous Transmitter:** Indicate any air interface/bands that operate in simultaneous or concurrent





service transmission mode.

- 3) **Name of Voice Service:** See Q4 in 285076 D03 HAC FAQ for further clarification.

## 4. Volume Control Test Requirements and Restrictions

### 4.1. Conversational Gain Performance

1. According to KDB 285076D05, for the 2N mounting force test, one narrowband and one wideband voice codec embedded with the handset must pass with at least one volume control setting with a Conversational gain of  $\geq 6$  dB for all voice services, bands of operation and air interfaces over which it operates using one codec bit rate of the applicant's choosing.
2. According to KDB 285076D05, for the 8N mounting force test, one narrowband and one wideband voice codec embedded with the handset must pass with at least one volume control setting with a Conversational gain of  $\geq 6$  dB for all voice services, bands of operation and air interfaces over which they operate but is not required to meet or exceed the full 18 dB of Conversational gain specified in section 5.1.1 of the TIA 5050 Volume Control Standard using one codec bit rate of the applicant's choosing.
3. Calculate the Conversational Gain by subtracting 70 dB from the measured dB SPL. That is Monoaural Conversational Gain = (Measured dB SPL Level - 70 dB SPL) dB.

### 4.2. Receive Distortion and Noise Performance

With a mounting force of 8N and 2N, the ratio of the stimulus signal power to the 100 Hz to 8000 Hz total A-weighted distortion and noise power shall be  $\geq 20$  dB when tested over the range of 1/3 octave band center frequencies:

1. Narrowband transmission mode: Each 1/3 octave band center frequency from 400 Hz to 3150 Hz.
2. Wideband transmission mode: Each 1/3 octave band center frequency from 250 Hz to 5000 Hz.
3. According to KDB 285076 D05, choosing one narrowband and one wideband for all voice services, bands of operation and air interfaces over which it operates using one codec bit rate of the applicant's choosing to meet Receive Distortion and Noise requirement.

### 4.3. Receive Acoustic Frequency Response Performance

The receive acoustic frequency response is required to be met when tested with a handset mounting force of 2N and 8N. For a hearing device, a 2N force is used to simulate usage of the handset by a person with a hearing device in the microphone (acoustic) mode.



The receive frequency response is the ratio of the output sound pressure at the listener reference point (LRP) (FF or DF) to the voltage input to the reference codec, or digital bit stream equivalent, as shown in Eq 1 for each frequency or frequency band ( $f_i$ ):

$$S_{JE} = 20 \log_{10} (P_E/V_R) \text{ dB re 1 Pa/V} \tag{Eq 1}$$

Where

$S_{JE}$  = Receive Sensitivity, Junction to Ear, at  $f_i$ .

$P_E$  = LRP sound pressure measured by ear simulator at DRP and translated to the FF or DF (see Annex B), at  $f_i$ .

$V_R$  = RMS input voltage to the reference codec, or digital bit stream equivalent, at  $f_i$ .

For the volume control settings determined in section 5.1.1 of ANSI/TIA-5050 with a mounting force of 8N and 2N, the receive frequency response shall be measured at the DRP in 1/12 octave bands. After translation to the FF or DF, it shall fall between the applicable upper and lower limits.

The exact limit values at any 1/12 octave band center frequency falling between two consecutive points specified in the table may be calculated using the formula given in Eq 2 below:

$$X_f = X_1 + (X_2 - X_1) * \left( \frac{\log_{10} f - \log_{10} f_1}{\log_{10} f_2 - \log_{10} f_1} \right) \tag{Eq 2}$$

Where

$X_f$  = limit value at frequency  $f$

$X_1$  = limit value at frequency  $f_1$  as given in table

$X_2$  = limit value at frequency  $f_2$  as given in table

1. Narrowband: The 1/12 octave band frequency response after translation to the FF or DF shall fall between the upper and lower limits below.

| Lower Limit Frequency (Hz) | Lower Limit (dB) |
|----------------------------|------------------|
| 300                        | -6               |
| 3400                       | -6               |
| Upper Limit Frequency (Hz) | Upper Limit (dB) |
| 100                        | +6               |
| 4000                       | +6               |

2. Wideband: The 1/12 octave band frequency response after translation to the FF or DF shall fall between the upper and lower limits below.



| Lower Limit Frequency (Hz) | Lower Limit (dB) |
|----------------------------|------------------|
| 200                        | -10              |
| 300                        | -6               |
| 500                        | -6               |
| 6300                       | -12              |
| Upper Limit Frequency (Hz) | Upper Limit (dB) |
| 100                        | +6               |
| 1000                       | +6               |
| 2000                       | +8               |
| 8000                       | +8               |

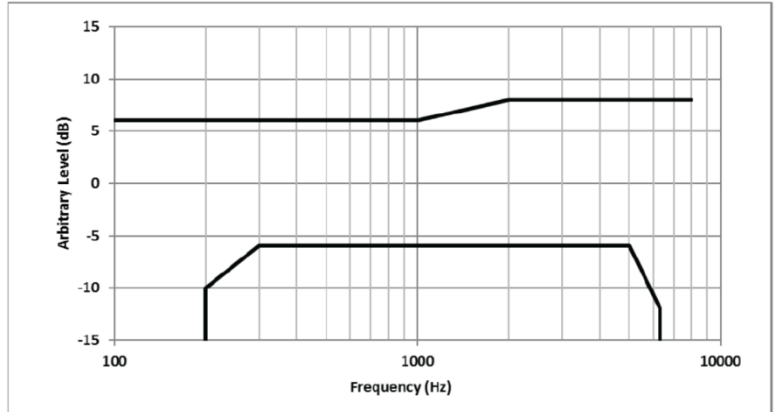

## 5. Volume Control Measurement System

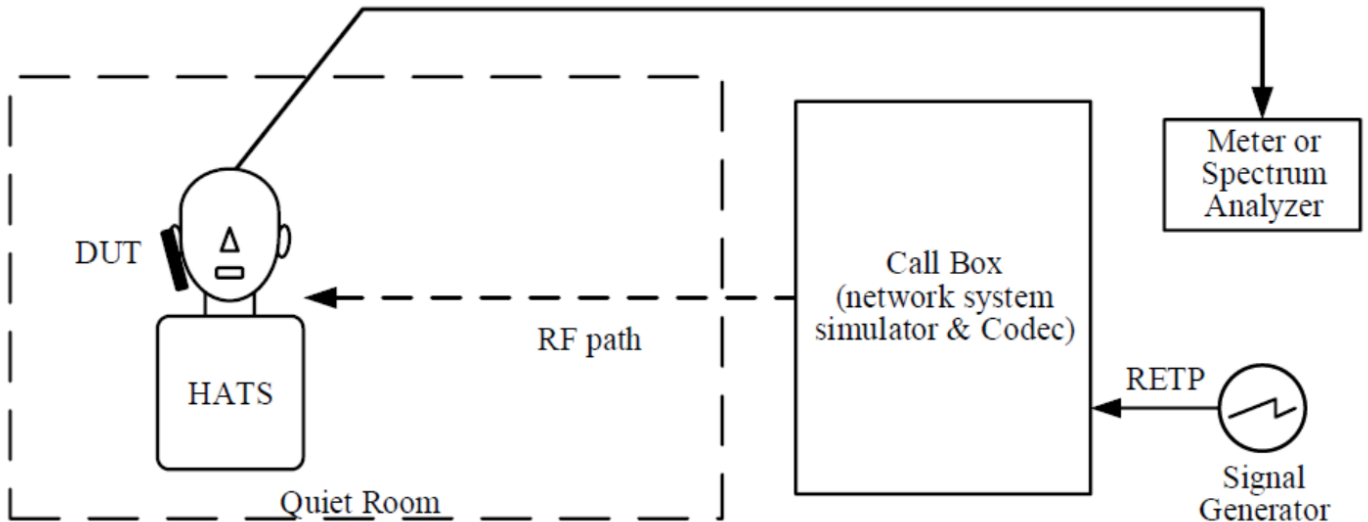

**Fig 5.1 Volume Control System Configurations**

**Note:**

1. A room with background noise no greater than 40 dBA.
2. The Call Box passes the voice channel stream to the DUT without modification. There is no gain or loss in the voice channel stream due to the Call Box interface.
3. The RETP (receive electrical test point) is the point in the device test arrangement where signals are applied to the DUT in the receive direction.
4. Per C63 & KDB 285076 D02v03, define the all applicable input audio level:
  - 1) GSM input level: -16dBm0
  - 2) UMTS input level: -16dBm0
  - 3) VoLTE input level: -16dBm0
  - 4) VoWiFi input level: -20dBm0
  - 5) OTT VoIP input level: -20dBm0
5. The callbox of CMW500 is used to GSM, UMTS, 1xRTT of CDMA200, VoLTE over IMS and Vo-WiFi over IMS Volume Control measurement, the data application unit of the CMW500 was used to simulate the IP multimedia subsystem server. And the CMW500 can be manually configured to ensure and control the speech input level result is -16dBm0 for VoLTE and -20dBm0 for VoWiFi when the device during the IMS connection.



## 6. Volume Control Measurement Procedure

### <Conversational Gain Performance>

1. Configure the DUT with a mounting force of 8N and test equipment as shown in Figure 1 in an active call state with the applicable codec for the transmission mode under test.
2. Set the DUT volume control to the maximum setting.
3. If the DUT has an adjustable tone control feature, a tone control setting that meets the frequency response requirements in ANSI/TIA-5050 section 5.3.1 shall be used.
4. Apply the real speech test signal at a level of -20 dBm0 at the RETP and measure the acoustic output at the Drum Reference Point (DRP) over one complete sequence of the test signal.
5. Translate the measurement made at the DRP to the Free Field (FF) using the translation data in Annex B of ANSI/TIA-5050.
6. Over the applicable frequency band, determine the ASL in dB SPL for the resulting sound pressure level in accordance with Method B of ITU-T Recommendation P.56:
  - a. Narrowband 100 Hz through 4000 Hz.
  - b. Wideband 100 Hz through 7720 Hz.
7. Calculate the Conversational Gain by subtracting 70 dB from the measured dB SPL.  
[Conversational Gain = (Measured dB SPL Level - 70 dB SPL) dB]
8. Measure the output distortion per clause 5.2. If a distortion failure occurs at the maximum volume control setting, reduce the volume control setting and repeat the measurement to determine if a setting can be found for which the conversational gain requirement is met without a distortion failure.
9. Repeat steps 2-8 with a mounting force of 2N.

### <Receive Distortion and Noise Performance>

1. Configure the DUT with a mounting force of 8N and test equipment as shown in Figure 1 in an active call state with the applicable codec for the transmission mode under test with the volume control at the setting determined in 5.1.1 of ANSI/TIA-5050.
2. Receive distortion and noise is measured using the PN-SDNR procedure as described in Annex A of ANSI/TIA-5050.
3. To ensure DUT activation, apply the real speech test signal at a level of -20 dBm0 followed immediately by the initial 1/3 octave center frequency PN test signal in Table A.1 of ANSI/TIA-5050 based on the narrowband or wideband operating mode. Measure the acoustic output at the DRP over the complete sequence of the PN test signal.
4. Translate the measurement made at the DRP to the FF using the translation data in Annex B of ANSI/TIA-5050.
5. Calculate the acoustic output unweighted total signal power of the stimulus measurement band as described in A.2 of ANSI/TIA-5050.
6. Calculate the notched A-weighting distortion and noise components as described in A.3 of ANSI/TIA-5050.



7. Calculate the ratio of the signal power to the total A-weighted distortion and noise power using Eq A-1 of ANSI/TIA-5050.
8. Repeat for each of the remaining 1/3 octave center frequencies in Table A.1 of ANSI/TIA-5050 based on the narrowband or wideband operating mode.
9. Repeat steps 2-8 with a mounting force of 2N.

**<Receive Acoustic Frequency Response Performance>**

1. Configure the DUT with a mounting force of 8N and test equipment as shown in Figure 1 in an active call state with the applicable codec for the transmission mode under test with the volume control at the setting determined in 5.1.1 of ANSI/TIA-5050.
2. If the DUT has an adjustable tone control feature the initial measurement is to be performed with the default tone control setting.
3. Apply the real speech test signal with a level of -20 dBm0 at the RETP.
4. Capture the frequency spectrum at the DRP of the HATS using real-time analysis with 1/12 octave bands over the frequency range from 100 Hz to 4000 Hz for narrowband measurements, or over the frequency range from 100 Hz to 8000 Hz for wideband measurements, averaged over the entire duration of the test signal.
5. Transform the DRP frequency spectrum measurement to the FF or DF (see Annex B of ANSI/TIA-5050).
6. Divide the 1/12 octave measurement data by the 1/12 octave frequency spectrum of the test signal at the RETP and present the measurement in terms of dB(Pa/V).
7. Apply the applicable frequency response limits to determine compliance.
8. If the default tone control setting does not meet the requirement, repeat the above steps for other tone control settings to determine a tone control setting that meets the requirements.
9. Repeat with a mounting force of 2N

## 7. Test Equipment List

| Manufacturer | Name of Equipment | Type/Model   | Serial Number | Calibration |            |
|--------------|-------------------|--------------|---------------|-------------|------------|
|              |                   |              |               | Last Cal.   | Due Date   |
| NTi AUDIO    | Audio Analyzer    | FLexus FX100 | 11762         | NCR         | NCR        |
| NTi AUDIO    | Audio Holder      | N/A          | 1094          | NCR         | NCR        |
| ETS          | HC-54892          | N/A          | 11762         | 2023.06.05  | 2024.06.04 |
| ETS          | Anechoic Chamber  | N/A          | HC-54892      | NCR         | NCR        |
| R&S          | Base Station      | CMW500       | 165755        | 2024.01.25  | 2025.01.24 |



## 8. Supported Codec Summary

### <General Guidance>

1. According to KDB 285076 D04, it's not required that every combination of codec, codec data rate, air interface, band, band channel, bandwidth, modulation data rate, subcarrier spacings, and resource blocks to be documented in a test report. However, it is expected to investigate and document only the worst-case test conditions and results. Each submitted test report shall document the codec type (i.e., NB, WB, EVS, etc.), every air interface (i.e., LTE, 5G NR, WI-FI), and band supported for the worst-case codec bit rate, band channel, bandwidth, air interface bit rate, subcarrier spacings, and resource blocks.
2. According to KDB 285076 D05 only CMRS narrowband and CMRS wideband voice codecs are required to comply with the volume control requirements of the ANSI/TIA 5050 Volume Control Standard. Other codecs out of 3GPP such as full-band and super-wideband codec or OTT VoIP codecs should be documented in the test report but not required to comply with the requirements of ANSI/TIA 5050.

### <Codec Summary>

| Wireless Mode | Codec/Bitrates (kbps) |        |         |        |        |         |
|---------------|-----------------------|--------|---------|--------|--------|---------|
|               | AMR NB                | AMR WB | EVS SWB | EVS WB | EVS NB | EVS FWB |
| GSM           | 4.75                  | 6.60   |         |        |        |         |
|               | 5.15                  | 8.85   |         |        |        |         |
|               | 5.90                  | 12.65  |         |        |        |         |
|               | 7.40                  | 14.25  |         |        |        |         |
|               | 7.95                  | 15.85  |         |        |        |         |
|               | 10.20                 | 18.25  |         |        |        |         |
|               | 12.20                 | 19.85  |         |        |        |         |
|               | 6.70                  | 23.05  |         |        |        |         |
|               |                       | 23.85  |         |        |        |         |
| WCDMA         | 4.75                  | 6.60   |         |        |        |         |
|               | 5.15                  | 8.85   |         |        |        |         |
|               | 5.90                  | 12.65  |         |        |        |         |
|               | 6.60                  | 14.25  |         |        |        |         |
|               | 7.40                  | 15.85  |         |        |        |         |
|               | 7.95                  | 18.25  |         |        |        |         |
|               | 10.20                 | 19.85  |         |        |        |         |
|               | 12.20                 | 23.05  |         |        |        |         |
|               |                       | 23.85  |         |        |        |         |
| VoLTE         | 4.75                  | 6.60   | 9.6     | 5.9    | 5.9    |         |



|        |       |       |      |      |      |  |
|--------|-------|-------|------|------|------|--|
|        | 5.15  | 8.85  | 13.2 | 7.2  | 7.2  |  |
|        | 5.90  | 12.65 | 16.4 | 8.0  | 8.0  |  |
|        | 6.60  | 14.25 | 24.4 | 9.6  | 9.6  |  |
|        | 7.40  | 15.85 | 32   | 13.2 | 13.2 |  |
|        | 7.95  | 18.25 |      | 16.4 | 16.4 |  |
|        | 10.20 | 19.85 |      | 24.4 | 24.4 |  |
|        | 12.20 | 23.05 |      |      |      |  |
|        |       | 23.85 |      |      |      |  |
|        |       |       |      |      |      |  |
| VoWiFi | 4.75  | 6.60  | 9.6  | 5.9  | 5.9  |  |
|        | 5.15  | 8.85  | 13.2 | 7.2  | 7.2  |  |
|        | 5.90  | 12.65 | 16.4 | 8.0  | 8.0  |  |
|        | 6.60  | 14.25 | 24.4 | 9.6  | 9.6  |  |
|        | 7.40  | 15.85 |      | 13.2 | 13.2 |  |
|        | 7.95  | 18.25 |      | 16.4 | 16.4 |  |
|        | 10.20 | 19.85 |      | 24.4 | 24.4 |  |
|        | 12.20 | 23.05 |      |      |      |  |
|        |       | 23.85 |      |      |      |  |





## 9. Test Results Summary

### 9.1. General Guidance

1. The middle channel of each frequency band is used to Volume Control.
2. All of test configurations were tested under the maximum volume.
3. According to KDB 285076 D05, the technical testing requirements for the conversational gain, distortion, and frequency response tests that amends KDB 285076 D04 Volume Control under the conditions of the limited-term waiver DA 23-914, that
  - a. Under the waiver, only CMRS narrowband and CMRS wideband voice codecs are required to comply with the volume control requirements of the ANSI/TIA-5050 Volume Control Standard:
    - 1) For the 2N mounting force test, one narrowband and one wideband voice codec embedded with the handset must pass with at least one volume control setting with a conversational gain of  $\geq 6$  dB for all voice services, bands of operation and air interfaces over which it operates using one codec bit rate of the applicant's choosing.
    - 2) For the 8N mounting force test, one narrowband and one wideband voice codec embedded with the handset must pass with at least one volume control setting with a conversational gain of  $\geq 6$  dB for all voice services, bands of operation and air interfaces over which they operate but is not required to meet or exceed the full 18 dB of conversational gain specified in section 5.1.1 of the ANSI/TIA-5050 Volume Control Standard using one codec bit rate of the applicant's choosing.
  - b. For all other narrowband and wideband codecs not evaluated in 2.a. above, ANSI/TIA-5050 Receive Distortion and Noise Performance and Receive Acoustic Frequency Response Performance evaluations are not required; however, these codecs shall be assessed for conversational gain and documented in the test report at the 2N and 8N levels with a gain of  $\geq 6$  dB for all voice services, bands of operation and air interfaces over which they operate. The handset volume setting used to comply with 2.a. shall be used for these other CMRS codec evaluations.
  - c. Any other codec for voice services embedded in the handset, not identified in 2.a. and 2.b. above, is not required to comply or demonstrate in the test reports for conversational gain.
4. The worst ratio configuration (i.e., codec data rate, air interface, band, band channel, bandwidth, modulation data rate, subcarrier spacings, and resource blocks) through internal radio configuration investigation was documented as below.
5. The product is tested in the room with an ambient noise of less than 40 dBA.
6. The VOWIFI test mode is tested according to the worst mode of the T-Coil.
7. The distortion and noise test results data are referred to Annex C.



## 9.2. Test Results

➤ Test Results for KDB 285076 D05 2.a

| Volume Control Performance |                     |         |                |                    | Conversational Gain Performance |                 | Distortion and Noise Performance | Frequency Response Performance |
|----------------------------|---------------------|---------|----------------|--------------------|---------------------------------|-----------------|----------------------------------|--------------------------------|
| Air Interface              | Radio Configuration | Channel | Mounting Force | Codec Rates (Kbps) | Speech Level (dB SPL)           | Conv. Gain (dB) | Minimum PN-SDNR (dB)             | Free Field (FF)                |
| GSM 850                    | GSM Voice           | 189     | 2N             | AMR-NB 12.2        | 87.38                           | 17.38           | 39.75                            | PASS                           |
| GSM 850                    | GSM Voice           | 189     | 2N             | AMR-WB 12.65       | 87.73                           | 17.73           | 36.62                            | PASS                           |
| GSM 850                    | GSM Voice           | 189     | 8N             | AMR-NB 12.2        | 89.81                           | 19.81           | 41.02                            | PASS                           |
| GSM 850                    | GSM Voice           | 189     | 8N             | AMR-WB 12.65       | 88.73                           | 18.73           | 37.14                            | PASS                           |
| GSM 1900                   | GSM Voice           | 661     | 2N             | AMR-NB 12.2        | 90.03                           | 20.03           | 40.11                            | PASS                           |
| GSM 1900                   | GSM Voice           | 661     | 2N             | AMR-WB 12.65       | 87.99                           | 17.99           | 37.01                            | PASS                           |
| GSM 1900                   | GSM Voice           | 661     | 8N             | AMR-NB 12.2        | 90.52                           | 20.52           | 41.31                            | PASS                           |
| GSM 1900                   | GSM Voice           | 661     | 8N             | AMR-WB 12.65       | 89.38                           | 19.38           | 37.59                            | PASS                           |

| Volume Control Performance |                     |         |                |                    | Conversational Gain Performance |                 | Distortion and Noise Performance | Frequency Response Performance |
|----------------------------|---------------------|---------|----------------|--------------------|---------------------------------|-----------------|----------------------------------|--------------------------------|
| Air Interface              | Radio Configuration | Channel | Mounting Force | Codec Rates (Kbps) | Speech Level (dB SPL)           | Conv. Gain (dB) | Minimum PN-SDNR (dB)             | Free Field (FF)                |
| WCDMA II                   | AMR                 | 9400    | 2N             | AMR-NB 12.2        | 87.6                            | 17.6            | 39.92                            | PASS                           |
| WCDMA II                   | AMR                 | 9400    | 2N             | AMR-WB 12.65       | 87.85                           | 17.85           | 37.11                            | PASS                           |
| WCDMA II                   | AMR                 | 9400    | 8N             | AMR-NB 12.2        | 89.84                           | 19.84           | 41.02                            | PASS                           |
| WCDMA II                   | AMR                 | 9400    | 8N             | AMR-WB 12.65       | 89.4                            | 19.4            | 37.88                            | PASS                           |
| WCDMA IV                   | AMR                 | 1413    | 2N             | AMR-NB 12.2        | 87.96                           | 17.96           | 39.69                            | PASS                           |
| WCDMA IV                   | AMR                 | 1413    | 2N             | AMR-WB 12.65       | 87.91                           | 17.91           | 36.98                            | PASS                           |
| WCDMA IV                   | AMR                 | 1413    | 8N             | AMR-NB 12.2        | 89.82                           | 19.82           | 40.97                            | PASS                           |
| WCDMA IV                   | AMR                 | 1413    | 8N             | AMR-WB 12.65       | 89.31                           | 19.31           | 37.34                            | PASS                           |
| WCDMA V                    | AMR                 | 4182    | 2N             | AMR-NB 12.2        | 86.37                           | 16.37           | 39.82                            | PASS                           |



|         |     |      |    |              |       |       |       |      |
|---------|-----|------|----|--------------|-------|-------|-------|------|
| WCDMA V | AMR | 4182 | 2N | AMR-WB 12.65 | 87.56 | 17.56 | 36.81 | PASS |
| WCDMA V | AMR | 4182 | 8N | AMR-NB 12.2  | 89.58 | 19.58 | 40.86 | PASS |
| WCDMA V | AMR | 4182 | 8N | AMR-WB 12.65 | 89.18 | 19.18 | 37.26 | PASS |

<FDD LTE>

| Volume Control Performance |                     |         |                |                    | Conversational Gain Performance |                 | Distortion and Noise Performance | Frequency Response Performance |
|----------------------------|---------------------|---------|----------------|--------------------|---------------------------------|-----------------|----------------------------------|--------------------------------|
| Air Interface              | Radio Configuration | Channel | Mounting Force | Codec Rates (Kbps) | Speech Level (dB SPL)           | Conv. Gain (dB) | Minimum PN-SDNR (dB)             | Free Field (FF)                |
| LTE Band 2                 | 20M_QPSK_1#0        | 18900   | 2N             | AMR-NB 12.2        | 86.56                           | 16.56           | 37.24                            | PASS                           |
| LTE Band 2                 | 20M_QPSK_1#0        | 18900   | 2N             | AMR-WB 12.65       | 87.89                           | 17.89           | 37.55                            | PASS                           |
| LTE Band 2                 | 20M_QPSK_1#0        | 18900   | 8N             | AMR-NB 12.2        | 89.68                           | 19.68           | 41.19                            | PASS                           |
| LTE Band 2                 | 20M_QPSK_1#0        | 18900   | 8N             | AMR-WB 12.65       | 89.33                           | 19.33           | 38.02                            | PASS                           |
| LTE Band 4                 | 20M_QPSK_1#0        | 20175   | 2N             | AMR-NB 12.2        | 89.11                           | 19.11           | 40.59                            | PASS                           |
| LTE Band 4                 | 20M_QPSK_1#0        | 20175   | 2N             | AMR-WB 12.65       | 87.9                            | 17.9            | 37.6                             | PASS                           |
| LTE Band 4                 | 20M_QPSK_1#0        | 20175   | 8N             | AMR-NB 12.2        | 90.07                           | 20.07           | 41.61                            | PASS                           |
| LTE Band 4                 | 20M_QPSK_1#0        | 20175   | 8N             | AMR-WB 12.65       | 89.42                           | 19.42           | 38.39                            | PASS                           |
| LTE Band 5                 | 10M_QPSK_1#0        | 20525   | 2N             | AMR-NB 12.2        | 84.8                            | 14.8            | 37.24                            | PASS                           |
| LTE Band 5                 | 10M_QPSK_1#0        | 20525   | 2N             | AMR-WB 12.65       | 87.81                           | 17.81           | 36.99                            | PASS                           |
| LTE Band 5                 | 10M_QPSK_1#0        | 20525   | 8N             | AMR-NB 12.2        | 89.74                           | 19.74           | 41.07                            | PASS                           |
| LTE Band 5                 | 10M_QPSK_1#0        | 20525   | 8N             | AMR-WB 12.65       | 88.95                           | 18.95           | 38.26                            | PASS                           |
| LTE Band 7                 | 20M_QPSK_1#0        | 21100   | 2N             | AMR-NB 12.2        | 88.14                           | 18.14           | 37.11                            | PASS                           |
| LTE Band 7                 | 20M_QPSK_1#0        | 21100   | 2N             | AMR-WB 12.65       | 87.88                           | 17.88           | 37.24                            | PASS                           |
| LTE Band 7                 | 20M_QPSK_1#0        | 21100   | 8N             | AMR-NB 12.2        | 89.86                           | 19.86           | 41.2                             | PASS                           |
| LTE Band 7                 | 20M_QPSK_1#0        | 21100   | 8N             | AMR-WB 12.65       | 89.29                           | 19.29           | 38.61                            | PASS                           |
| LTE Band 12                | 10M_QPSK_1#0        | 23095   | 2N             | AMR-NB 12.2        | 85.79                           | 15.79           | 37.5                             | PASS                           |
| LTE Band 12                | 10M_QPSK_1#0        | 23095   | 2N             | AMR-WB 12.65       | 87.74                           | 17.74           | 36.17                            | PASS                           |
| LTE Band 12                | 10M_QPSK_1#0        | 23095   | 8N             | AMR-NB 12.2        | 89.69                           | 19.69           | 40.93                            | PASS                           |
| LTE Band 12                | 10M_QPSK_1#0        | 23095   | 8N             | AMR-WB 12.65       | 89.18                           | 19.18           | 38.2                             | PASS                           |



|             |              |        |    |              |       |       |       |      |
|-------------|--------------|--------|----|--------------|-------|-------|-------|------|
| LTE Band 13 | 10M_QPSK_1#0 | 23230  | 2N | AMR-NB 12.2  | 85.39 | 15.39 | 37.86 | PASS |
| LTE Band 13 | 10M_QPSK_1#0 | 23230  | 2N | AMR-WB 12.65 | 87.8  | 17.8  | 36.42 | PASS |
| LTE Band 13 | 10M_QPSK_1#0 | 23230  | 8N | AMR-NB 12.2  | 89.73 | 19.73 | 40.74 | PASS |
| LTE Band 13 | 10M_QPSK_1#0 | 23230  | 8N | AMR-WB 12.65 | 89.1  | 19.1  | 38.03 | PASS |
| LTE Band 17 | 10M_QPSK_1#0 | 23790  | 2N | AMR-NB 12.2  | 85.27 | 15.27 | 38.64 | PASS |
| LTE Band 17 | 10M_QPSK_1#0 | 23790  | 2N | AMR-WB 12.65 | 87.71 | 17.71 | 36.21 | PASS |
| LTE Band 17 | 10M_QPSK_1#0 | 23790  | 8N | AMR-NB 12.2  | 89.62 | 19.62 | 41.05 | PASS |
| LTE Band 17 | 10M_QPSK_1#0 | 23790  | 8N | AMR-WB 12.65 | 89.04 | 19.04 | 38.2  | PASS |
| LTE Band 25 | 20M_QPSK_1#0 | 26365  | 2N | AMR-NB 12.2  | 86.45 | 16.45 | 38.24 | PASS |
| LTE Band 25 | 20M_QPSK_1#0 | 26365  | 2N | AMR-WB 12.65 | 87.82 | 17.82 | 37.72 | PASS |
| LTE Band 25 | 20M_QPSK_1#0 | 26365  | 8N | AMR-NB 12.2  | 89.62 | 19.62 | 41.23 | PASS |
| LTE Band 25 | 20M_QPSK_1#0 | 26365  | 8N | AMR-WB 12.65 | 89.18 | 19.18 | 39.47 | PASS |
| LTE Band 66 | 20M_QPSK_1#0 | 132322 | 2N | AMR-NB 12.2  | 88.63 | 18.63 | 39.89 | PASS |
| LTE Band 66 | 20M_QPSK_1#0 | 132322 | 2N | AMR-WB 12.65 | 87.91 | 17.91 | 37.39 | PASS |
| LTE Band 66 | 20M_QPSK_1#0 | 132322 | 8N | AMR-NB 12.2  | 90.12 | 20.12 | 42.2  | PASS |
| LTE Band 66 | 20M_QPSK_1#0 | 132322 | 8N | AMR-WB 12.65 | 89.37 | 19.37 | 38.77 | PASS |
| LTE Band 71 | 20M_QPSK_1#0 | 133322 | 2N | AMR-NB 12.2  | 86.92 | 16.92 | 40.59 | PASS |
| LTE Band 71 | 20M_QPSK_1#0 | 133322 | 2N | AMR-WB 12.65 | 86.88 | 16.88 | 36.95 | PASS |
| LTE Band 71 | 20M_QPSK_1#0 | 133322 | 8N | AMR-NB 12.2  | 87.11 | 17.11 | 42.07 | PASS |
| LTE Band 71 | 20M_QPSK_1#0 | 133322 | 8N | AMR-WB 12.65 | 87.02 | 17.02 | 39.23 | PASS |

<WLAN 2.4GHz & 5GHz>

| Volume Control Performance |                     |         |                |                    | Conversational Gain Performance |                 | Distortion and Noise Performance | Frequency Response Performance |
|----------------------------|---------------------|---------|----------------|--------------------|---------------------------------|-----------------|----------------------------------|--------------------------------|
| Air Interface              | Radio Configuration | Channel | Mounting Force | Codec Rates (Kbps) | Speech Level (dB SPL)           | Conv. Gain (dB) | Minimum PN-SDNR (dB)             | Free Field (FF)                |
| WLAN 2.4GHz                | 802.11b 1Mbps       | 6       | 2N             | AMR-NB 12.2        | 106.8                           | 36.8            | 40.98                            | PASS                           |
| WLAN 2.4GHz                | 802.11b 1Mbps       | 6       | 2N             | AMR-WB 12.65       | 107.2                           | 37.2            | 37.47                            | PASS                           |



|             |               |     |    |              |       |      |       |      |
|-------------|---------------|-----|----|--------------|-------|------|-------|------|
| WLAN 2.4GHz | 802.11b 1Mbps | 6   | 8N | AMR-NB 12.2  | 107.9 | 37.9 | 40.8  | PASS |
| WLAN 2.4GHz | 802.11b 1Mbps | 6   | 8N | AMR-WB 12.65 | 108.4 | 38.4 | 38.59 | PASS |
| WLAN 5.2GHz | 802.11a 6Mbps | 44  | 2N | AMR-NB 12.2  | 107.3 | 37.3 | 42.55 | PASS |
| WLAN 5.2GHz | 802.11a 6Mbps | 44  | 2N | AMR-WB 12.65 | 107.6 | 37.6 | 34.98 | PASS |
| WLAN 5.2GHz | 802.11a 6Mbps | 44  | 8N | AMR-NB 12.2  | 109.2 | 39.2 | 41.58 | PASS |
| WLAN 5.2GHz | 802.11a 6Mbps | 44  | 8N | AMR-WB 12.65 | 109.3 | 39.3 | 35.33 | PASS |
| WLAN 5.3GHz | 802.11a 6Mbps | 60  | 2N | AMR-NB 12.2  | 108.2 | 38.2 | 40.79 | PASS |
| WLAN 5.3GHz | 802.11a 6Mbps | 60  | 2N | AMR-WB 12.65 | 108   | 38   | 36.51 | PASS |
| WLAN 5.3GHz | 802.11a 6Mbps | 60  | 8N | AMR-NB 12.2  | 110.1 | 40.1 | 42.53 | PASS |
| WLAN 5.3GHz | 802.11a 6Mbps | 60  | 8N | AMR-WB 12.65 | 109.7 | 39.7 | 38.42 | PASS |
| WLAN 5.5GHz | 802.11a 6Mbps | 120 | 2N | AMR-NB 12.2  | 106.6 | 36.6 | 40.69 | PASS |
| WLAN 5.5GHz | 802.11a 6Mbps | 120 | 2N | AMR-WB 12.65 | 106.5 | 36.5 | 34.92 | PASS |
| WLAN 5.5GHz | 802.11a 6Mbps | 120 | 8N | AMR-NB 12.2  | 108.3 | 38.3 | 40.13 | PASS |
| WLAN 5.5GHz | 802.11a 6Mbps | 120 | 8N | AMR-WB 12.65 | 108.1 | 38.1 | 36.88 | PASS |
| WLAN 5.8GHz | 802.11a 6Mbps | 157 | 2N | AMR-NB 12.2  | 107.1 | 37.1 | 41.77 | PASS |
| WLAN 5.8GHz | 802.11a 6Mbps | 157 | 2N | AMR-WB 12.65 | 107.4 | 37.4 | 36.41 | PASS |
| WLAN 5.8GHz | 802.11a 6Mbps | 157 | 8N | AMR-NB 12.2  | 109.3 | 39.3 | 40.81 | PASS |
| WLAN 5.8GHz | 802.11a 6Mbps | 157 | 8N | AMR-WB 12.65 | 109.4 | 39.4 | 38.44 | PASS |

➤ Test Results for KDB 285076 D05 2.b

<FDD LTE>

| Air Interface | Modulation / Mode | Channel | Mounting Force | Codec Rates (Kbps) | Speech Level (dB SPL) | Conversational Gain (dB) | Margin to Limit (dB) |
|---------------|-------------------|---------|----------------|--------------------|-----------------------|--------------------------|----------------------|
| LTE B2        | 20M_QPSK_1#0      | 18900   | 2N             | EVS-NB 24.4        | 86.64                 | 16.64                    | 10.64                |
| LTE B2        | 20M_QPSK_1#0      | 18900   | 2N             | EVS-WB 24.4        | 85.83                 | 15.83                    | 9.83                 |
| LTE B2        | 20M_QPSK_1#0      | 18900   | 2N             | EVS-SWB 24.4       | 85.85                 | 15.85                    | 9.85                 |
| LTE B2        | 20M_QPSK_1#0      | 18900   | 8N             | EVS-NB 24.4        | 88.74                 | 18.74                    | 12.74                |
| LTE B2        | 20M_QPSK_1#0      | 18900   | 8N             | EVS-WB 24.4        | 88.98                 | 18.98                    | 12.98                |
| LTE B2        | 20M_QPSK_1#0      | 18900   | 8N             | EVS-SWB 24.4       | 88.7                  | 18.7                     | 12.7                 |
| LTE B4        | 20M_QPSK_1#0      | 20175   | 2N             | EVS-NB 24.4        | 86.83                 | 16.83                    | 10.83                |



|         |              |       |    |              |       |       |       |
|---------|--------------|-------|----|--------------|-------|-------|-------|
| LTE B4  | 20M_QPSK_1#0 | 20175 | 2N | EVS-WB 24.4  | 85.86 | 15.86 | 9.86  |
| LTE B4  | 20M_QPSK_1#0 | 20175 | 2N | EVS-SWB 24.4 | 85.9  | 15.9  | 9.9   |
| LTE B4  | 20M_QPSK_1#0 | 20175 | 8N | EVS-NB 24.4  | 88.86 | 18.86 | 12.86 |
| LTE B4  | 20M_QPSK_1#0 | 20175 | 8N | EVS-WB 24.4  | 89.03 | 19.03 | 13.03 |
| LTE B4  | 20M_QPSK_1#0 | 20175 | 8N | EVS-SWB 24.4 | 88.76 | 18.76 | 12.76 |
|         |              |       |    |              |       |       |       |
| LTE B5  | 10M_QPSK_1#0 | 20525 | 2N | EVS-NB 24.4  | 86.48 | 16.48 | 10.48 |
| LTE B5  | 10M_QPSK_1#0 | 20525 | 2N | EVS-WB 24.4  | 85.77 | 15.77 | 9.77  |
| LTE B5  | 10M_QPSK_1#0 | 20525 | 2N | EVS-SWB 24.4 | 85.84 | 15.84 | 9.84  |
| LTE B5  | 10M_QPSK_1#0 | 20525 | 8N | EVS-NB 24.4  | 88.61 | 18.61 | 12.61 |
| LTE B5  | 10M_QPSK_1#0 | 20525 | 8N | EVS-WB 24.4  | 88.88 | 18.88 | 12.88 |
| LTE B5  | 10M_QPSK_1#0 | 20525 | 8N | EVS-SWB 24.4 | 88.68 | 18.68 | 12.68 |
|         |              |       |    |              |       |       |       |
| LTE B7  | 20M_QPSK_1#0 | 21100 | 2N | EVS-NB 24.4  | 86.69 | 16.69 | 10.69 |
| LTE B7  | 20M_QPSK_1#0 | 21100 | 2N | EVS-WB 24.4  | 85.89 | 15.89 | 9.89  |
| LTE B7  | 20M_QPSK_1#0 | 21100 | 2N | EVS-SWB 24.4 | 85.87 | 15.87 | 9.87  |
| LTE B7  | 20M_QPSK_1#0 | 21100 | 8N | EVS-NB 24.4  | 88.8  | 18.8  | 12.8  |
| LTE B7  | 20M_QPSK_1#0 | 21100 | 8N | EVS-WB 24.4  | 89    | 19    | 13    |
| LTE B7  | 20M_QPSK_1#0 | 21100 | 8N | EVS-SWB 24.4 | 88.71 | 18.71 | 12.71 |
|         |              |       |    |              |       |       |       |
| LTE B12 | 10M_QPSK_1#0 | 23095 | 2N | EVS-NB 24.4  | 86.55 | 16.55 | 10.55 |
| LTE B12 | 10M_QPSK_1#0 | 23095 | 2N | EVS-WB 24.4  | 85.8  | 15.8  | 9.8   |
| LTE B12 | 10M_QPSK_1#0 | 23095 | 2N | EVS-SWB 24.4 | 85.82 | 15.82 | 9.82  |
| LTE B12 | 10M_QPSK_1#0 | 23095 | 8N | EVS-NB 24.4  | 88.56 | 18.56 | 12.56 |
| LTE B12 | 10M_QPSK_1#0 | 23095 | 8N | EVS-WB 24.4  | 88.94 | 18.94 | 12.94 |
| LTE B12 | 10M_QPSK_1#0 | 23095 | 8N | EVS-SWB 24.4 | 88.67 | 18.67 | 12.67 |
|         |              |       |    |              |       |       |       |
| LTE B13 | 10M_QPSK_1#0 | 23230 | 2N | EVS-NB 24.4  | 86.58 | 16.58 | 10.58 |
| LTE B13 | 10M_QPSK_1#0 | 23230 | 2N | EVS-WB 24.4  | 85.81 | 15.81 | 9.81  |
| LTE B13 | 10M_QPSK_1#0 | 23230 | 2N | EVS-SWB 24.4 | 85.79 | 15.79 | 9.79  |
| LTE B13 | 10M_QPSK_1#0 | 23230 | 8N | EVS-NB 24.4  | 88.58 | 18.58 | 12.58 |
| LTE B13 | 10M_QPSK_1#0 | 23230 | 8N | EVS-WB 24.4  | 88.95 | 18.95 | 12.95 |
| LTE B13 | 10M_QPSK_1#0 | 23230 | 8N | EVS-SWB 24.4 | 88.66 | 18.66 | 12.66 |
|         |              |       |    |              |       |       |       |
| LTE B17 | 10M_QPSK_1#0 | 23790 | 2N | EVS-NB 24.4  | 86.54 | 16.54 | 10.54 |



|         |              |        |    |              |       |       |       |
|---------|--------------|--------|----|--------------|-------|-------|-------|
| LTE B17 | 10M_QPSK_1#0 | 23790  | 2N | EVS-WB 24.4  | 85.68 | 15.68 | 9.68  |
| LTE B17 | 10M_QPSK_1#0 | 23790  | 2N | EVS-SWB 24.4 | 85.64 | 15.64 | 9.64  |
| LTE B17 | 10M_QPSK_1#0 | 23790  | 8N | EVS-NB 24.4  | 88.51 | 18.51 | 12.51 |
| LTE B17 | 10M_QPSK_1#0 | 23790  | 8N | EVS-WB 24.4  | 87.69 | 17.69 | 11.69 |
| LTE B17 | 10M_QPSK_1#0 | 23790  | 8N | EVS-SWB 24.4 | 88.15 | 18.15 | 12.15 |
|         |              |        |    |              |       |       |       |
| LTE B25 | 20M_QPSK_1#0 | 26365  | 2N | EVS-NB 24.4  | 86.43 | 16.43 | 10.43 |
| LTE B25 | 20M_QPSK_1#0 | 26365  | 2N | EVS-WB 24.4  | 85.79 | 15.79 | 9.79  |
| LTE B25 | 20M_QPSK_1#0 | 26365  | 2N | EVS-SWB 24.4 | 85.74 | 15.74 | 9.74  |
| LTE B25 | 20M_QPSK_1#0 | 26365  | 8N | EVS-NB 24.4  | 88.91 | 18.91 | 12.91 |
| LTE B25 | 20M_QPSK_1#0 | 26365  | 8N | EVS-WB 24.4  | 88.67 | 18.67 | 12.67 |
| LTE B25 | 20M_QPSK_1#0 | 26365  | 8N | EVS-SWB 24.4 | 88.72 | 18.72 | 12.72 |
|         |              |        |    |              |       |       |       |
| LTE B66 | 20M_QPSK_1#0 | 132322 | 2N | EVS-NB 24.4  | 86.75 | 16.75 | 10.75 |
| LTE B66 | 20M_QPSK_1#0 | 132322 | 2N | EVS-WB 24.4  | 85.85 | 15.85 | 9.85  |
| LTE B66 | 20M_QPSK_1#0 | 132322 | 2N | EVS-SWB 24.4 | 85.95 | 15.95 | 9.95  |
| LTE B66 | 20M_QPSK_1#0 | 132322 | 8N | EVS-NB 24.4  | 88.83 | 18.83 | 12.83 |
| LTE B66 | 20M_QPSK_1#0 | 132322 | 8N | EVS-WB 24.4  | 89.01 | 19.01 | 13.01 |
| LTE B66 | 20M_QPSK_1#0 | 132322 | 8N | EVS-SWB 24.4 | 88.75 | 18.75 | 12.75 |
|         |              |        |    |              |       |       |       |
| LTE B71 | 20M_QPSK_1#0 | 133332 | 2N | EVS-NB 24.4  | 86.23 | 16.23 | 10.23 |
| LTE B66 | 20M_QPSK_1#0 | 133332 | 2N | EVS-WB 24.4  | 86.41 | 16.41 | 10.41 |
| LTE B66 | 20M_QPSK_1#0 | 133332 | 2N | EVS-SWB 24.4 | 86.35 | 16.35 | 10.35 |
| LTE B66 | 20M_QPSK_1#0 | 133332 | 8N | EVS-NB 24.4  | 86.85 | 16.85 | 10.85 |
| LTE B66 | 20M_QPSK_1#0 | 133332 | 8N | EVS-WB 24.4  | 86.91 | 16.91 | 10.91 |
| LTE B66 | 20M_QPSK_1#0 | 133332 | 8N | EVS-SWB 24.4 | 86.79 | 16.79 | 10.79 |

<WLAN>

| Air Interface | Modulation / Mode | Channel | Mounting Force | Codec Rates (Kbps) | Speech Level (dB SPL) | Conversational Gain (dB) | Margin to Limit (dB) |
|---------------|-------------------|---------|----------------|--------------------|-----------------------|--------------------------|----------------------|
| WLAN 2.4G     | 802.11g 6Mbps     | 6       | 2N             | EVS-NB 24.4        | 106.2                 | 36.2                     | 30.2                 |
| WLAN 2.4G     | 802.11g 6Mbps     | 6       | 2N             | EVS-WB 24.4        | 106.3                 | 36.3                     | 30.3                 |
| WLAN 2.4G     | 802.11g 6Mbps     | 6       | 2N             | EVS-SWB 24.4       | 105.9                 | 35.9                     | 29.9                 |
| WLAN 2.4G     | 802.11g 6Mbps     | 6       | 8N             | EVS-NB 24.4        | 107.1                 | 37.1                     | 31.1                 |
| WLAN 2.4G     | 802.11g 6Mbps     | 6       | 8N             | EVS-WB 24.4        | 107                   | 37                       | 31                   |



|           |               |     |    |              |       |      |      |
|-----------|---------------|-----|----|--------------|-------|------|------|
| WLAN 2.4G | 802.11g 6Mbps | 6   | 8N | EVS-SWB 24.4 | 106.8 | 36.8 | 30.8 |
| WLAN 5.2G | 802.11a 6Mbps | 44  | 2N | EVS-NB 24.4  | 106.8 | 36.8 | 30.8 |
| WLAN 5.2G | 802.11a 6Mbps | 44  | 2N | EVS-WB 24.4  | 106.9 | 36.9 | 30.9 |
| WLAN 5.2G | 802.11a 6Mbps | 44  | 2N | EVS-SWB 24.4 | 106.5 | 36.5 | 30.5 |
| WLAN 5.2G | 802.11a 6Mbps | 44  | 8N | EVS-NB 24.4  | 108.4 | 38.4 | 32.4 |
| WLAN 5.2G | 802.11a 6Mbps | 44  | 8N | EVS-WB 24.4  | 108.5 | 38.5 | 32.5 |
| WLAN 5.2G | 802.11a 6Mbps | 44  | 8N | EVS-SWB 24.4 | 108.3 | 38.3 | 32.3 |
| WLAN 5.3G | 802.11a 6Mbps | 60  | 2N | EVS-NB 24.4  | 106.2 | 36.2 | 30.2 |
| WLAN 5.3G | 802.11a 6Mbps | 60  | 2N | EVS-WB 24.4  | 106.5 | 36.5 | 30.5 |
| WLAN 5.3G | 802.11a 6Mbps | 60  | 2N | EVS-SWB 24.4 | 106.4 | 36.4 | 30.4 |
| WLAN 5.3G | 802.11a 6Mbps | 60  | 8N | EVS-NB 24.4  | 108.3 | 38.3 | 32.3 |
| WLAN 5.3G | 802.11a 6Mbps | 60  | 8N | EVS-WB 24.4  | 108.4 | 38.4 | 32.4 |
| WLAN 5.3G | 802.11a 6Mbps | 60  | 8N | EVS-SWB 24.4 | 107.9 | 37.9 | 31.9 |
| WLAN 5.5G | 802.11a 6Mbps | 120 | 2N | EVS-NB 24.4  | 105.7 | 35.7 | 29.7 |
| WLAN 5.5G | 802.11a 6Mbps | 120 | 2N | EVS-WB 24.4  | 105.8 | 35.8 | 29.8 |
| WLAN 5.5G | 802.11a 6Mbps | 120 | 2N | EVS-SWB 24.4 | 105.5 | 35.5 | 29.5 |
| WLAN 5.5G | 802.11a 6Mbps | 120 | 8N | EVS-NB 24.4  | 107.5 | 37.5 | 31.5 |
| WLAN 5.5G | 802.11a 6Mbps | 120 | 8N | EVS-WB 24.4  | 107.3 | 37.3 | 31.3 |
| WLAN 5.5G | 802.11a 6Mbps | 120 | 8N | EVS-SWB 24.4 | 107.2 | 37.2 | 31.2 |
| WLAN 5.8G | 802.11a 6Mbps | 157 | 2N | EVS-NB 24.4  | 106.2 | 36.2 | 30.2 |
| WLAN 5.8G | 802.11a 6Mbps | 157 | 2N | EVS-WB 24.4  | 106.4 | 36.4 | 30.4 |
| WLAN 5.8G | 802.11a 6Mbps | 157 | 2N | EVS-SWB 24.4 | 106   | 36   | 30   |
| WLAN 5.8G | 802.11a 6Mbps | 157 | 8N | EVS-NB 24.4  | 107.9 | 37.9 | 31.9 |
| WLAN 5.8G | 802.11a 6Mbps | 157 | 8N | EVS-WB 24.4  | 108.1 | 38.1 | 32.1 |
| WLAN 5.8G | 802.11a 6Mbps | 157 | 8N | EVS-SWB 24.4 | 107.8 | 37.8 | 31.8 |





## 10. Uncertainty Assessment

The component of uncertainty may generally be categorized according to the methods used to evaluate them. The evaluation of uncertainty by the statistical analysis of a series of observations is termed a Type A evaluation of uncertainty. The evaluation of uncertainty by means other than the statistical analysis of a series of observation is termed a Type B evaluation of uncertainty. Each component of uncertainty, however evaluated, is represented by an estimated standard deviation, termed standard uncertainty, which is determined by the positive square root of the estimated variance.

The combined standard uncertainty of the measurement result represents the estimated standard deviation of the result. It is obtained by combining the individual standard uncertainties of both Type A and Type B evaluation using the usual "root-sum-squares" (RSS) methods of combining standard deviations by taking the positive square root of the estimated variances. Expanded uncertainty is a measure of uncertainty that defines an interval about the measurement result within which the measured value is confidently believed to lie. It is obtained by multiplying the combined standard uncertainty by a coverage factor. For purpose of this document, a coverage factor two is used, which corresponds to confidence interval of about 95 %.

The judgment of conformity in the report is based on the measurement results excluding the measurement uncertainty.

### Declaration of Conformity:

The test results with all measurement uncertainty excluded is presented in accordance with the regulation limits or requirements declared by manufacturers.

### Comments and Explanations:

The declared of product specification for EUT presented in the report are provided by the manufacturer, and the manufacturer takes all the responsibilities for the accuracy of product specification.

| Component   | Standard Uncertainty (dB) | U <sup>2</sup> (% <sup>2</sup> ) |
|---|---------------------------|----------------------------------|
| Generator Accuracy<br>To enable harmonic distortion measurements to 0.1%, the generator distortion must be <0.05%. This is equivalent to a standard uncertainty of 0.043 dB.  | 0.043                     | 0.25                             |
| Ear Simulator Pressure Sensitivity (incl. Measurement Mic.)<br>The uncertainty of the ear simulator as per the standards and quoted on its calibration certificate is 0.3 dB with a coverage factor of k= 2. This is equivalent to a standard uncertainty of 0.3/2 = 0.15 dB. | 0.15                      | 3.03                             |
| Microphone Preamplifier<br>The manufacturer quotes the preamp to be within + 0.02 dB with a 95% probability or 2σ. This is equivalent to a standard uncertainty of 0.02/2 =0.01 dB.   | 0.01                      | 0.01                             |
| Analysis System / RMS Detector<br>Typical measurement system detector accuracy is 0.1 dB with a coverage factor of k= 2. This is equivalent to a standard uncertainty of 0.1/2 = 0.05 dB.   | 0.05                      | 0.33                             |
| Effect of Positioning on Mid-Band Sensitivity<br>For a handset, with the HATS positioning jig, the typical standard deviation estimated from a statistically significant number of measurements is +2 dB This is equivalent to a standard uncertainty of 2 dB.                | 2.0                       | 670.42                           |



|  |       |      |
|--|-------|------|
| Time Varying Effects of the Mouth Simulator for Send & Sidetone<br>For a receive measurement on a handset. the mouth simulator is not used (its uncertainty is zero), The standard uncertainty of 0 dB | 0     | 0.00 |
| Total Standard Uncertainty (%)   | 25.96 |      |
| UMAX (k=2) (%)   | 51.9  |      |
| UMAX (k=2) (dB)  | 3.6   |      |



## Annex A General Information

### 1. Identification of the Responsible Testing Laboratory

|                     |  |
|---------------------|--|
| Laboratory Name:    | Shenzhen Morlab Communications Technology Co., Ltd.  |
| Laboratory Address: | FL.1-3, Building A, FeiYang Science Park, No.8 LongChang Road, Block 67, BaoAn District, ShenZhen, GuangDong Province, P. R. China |
| Telephone:          | +86 755 36698555   |
| Facsimile:          | +86 755 36698525   |

### 2. Identification of the Responsible Testing Location

|          |  |
|----------|--|
| Name:    | Shenzhen Morlab Communications Technology Co., Ltd.  |
| Address: | FL.1-3, Building A, FeiYang Science Park, No.8 LongChang Road, Block 67, BaoAn District, ShenZhen, GuangDong Province, P. R. China |

### 3. Facilities and Accreditations

The FCC designation number is CN1192, the test firm registration number is 226174.



REPORT No.: SZ23110216S02

## **Annex B Test Setup Photos**

The annex B will be submitted separately.

## **Annex C Test Results Data of Distortion and Noise**

The annex C will be submitted separately.

## **Annex D Test Results of Volume Control**

The annex D will be submitted separately.

\*\*\*\*\* END OF MAIN REPORT \*\*\*\*\*