

The ASSA ABLOY Group is the global leader in access solutions. Every day we help people feel safe, secure and experience a more open world.

SAHARA MANUAL

Sahara Manual



Safety first



Stay home if you have flu symptoms

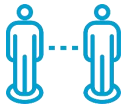

Keep your distance



Wash/sanitize hands



Alarm



Assembly point



Emergency exit



Emergency number



First aid kit



Protective equipment

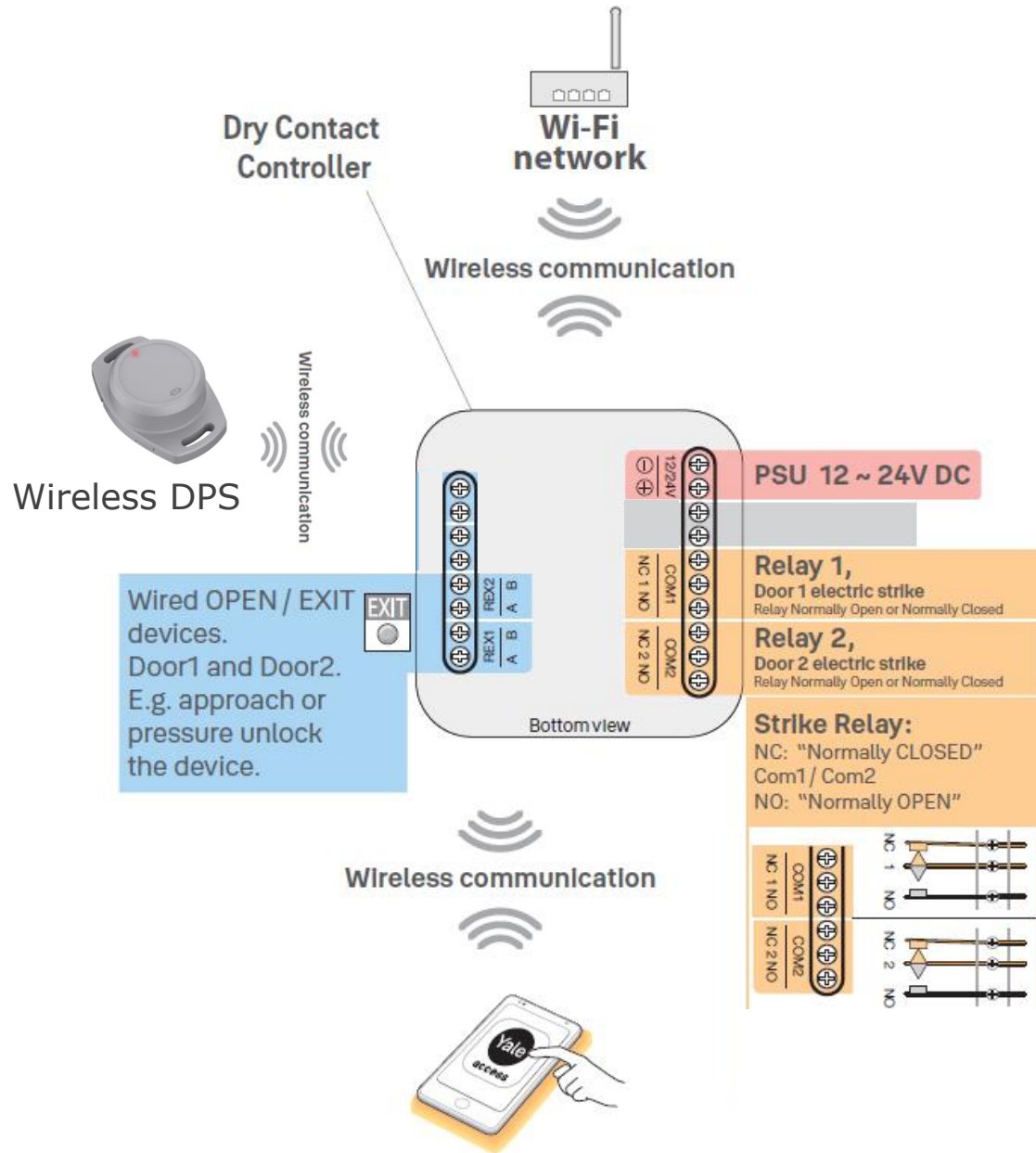

Sahara is a dry contact device that is built with Wi-Fi and Bluetooth connections that allow the Yale Access app to send an electric strike to a GDO (Garage door opener) or Gate automation device that is it connected to.

As part of its offering, we have also included a wireless DPS that will provide the end user with the correct state of the gate/ garage door.

Through the use of both devices, the end user can now control access into the garage or through their gate and also see what state the door is in.

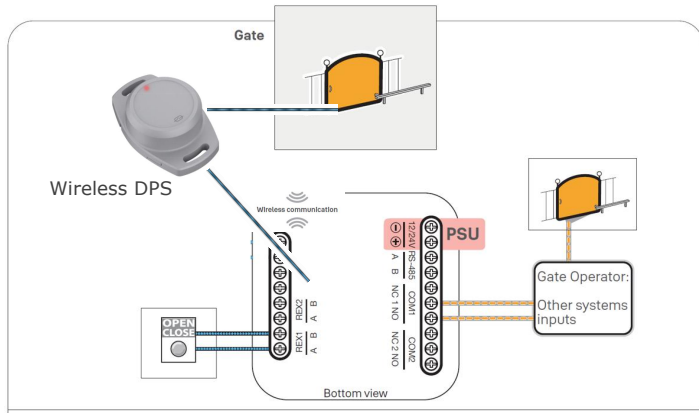

Hardware installation.

Step one

- The end user is asked to power down their Gate Automation device in order to avoid any electric interface and dangerous encounters.

Step two

- The end user should then take the wires coming out of the 'NO' (Normally open), 'Com1' ports, and power supply (5V/ 24V) of the Sahara and connect these to the relevant ports on a Gate Automation device. (As every automation device has its own port locations, this connection method will be shown to them through a wiring compatibility checker on the app and the website)

Step three

- Once installed, the end user is asked to power up their Gate Automation device if the LED light on the Sahara turns on then power is now available on the device.

Step four

- The end user will be asked to power the wireless DPS and then attach it to the gate door and take the magnet that comes with it and attach it to the pillar of the gate which will allow the app to know the state of the gate.

Step Five

- This is an optional step for end users. If they have a 'request for exit' switch inside their garage they can connect this to the rex1 or rex2 ports and so then they can continue to open and close their garage through the switch

Gate Application.

Step one.

- Remove Sahara from the box.

Step two

- Download the Yale Access App.

Step 3

- Scan the QR code on the Sahara an wireless DPS device that will take you through the registration process of your device on the Yale Access app and add the device to WiFi.

Step 4

- Hardware installation should now take place. The End user will be taken through a step-by-step guide on the Yale access app on how to install their Sahara, wireless DPS and magnet on a generic Gate Automation device (See hardware installation part to the right)

Step 5

- End user asked to test whether the device works after Sahara hardware installation is done

Step 6

- Now end users can use Sahara to open or close their gate (See example below).

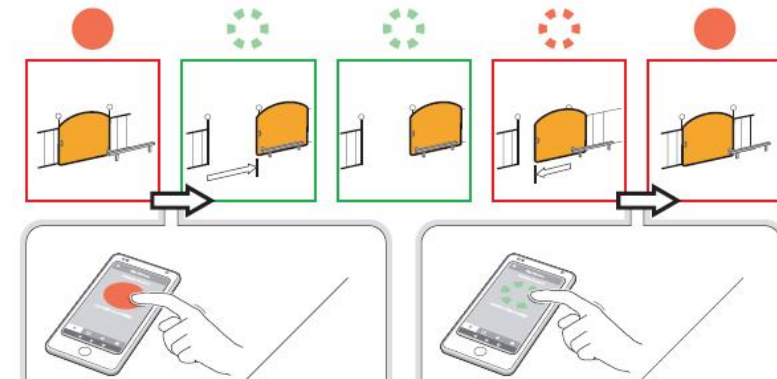

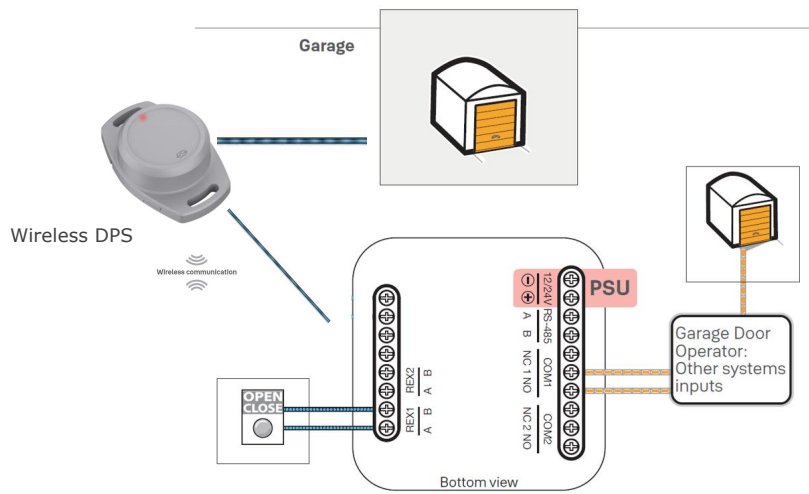

Hardware installation.

Step one

- The end user asked to power down their Garage door opener in order to avoid any electric interface and dangerous encounters.

Step two

- The end user should connect the wires from the 'NO' (Normally open), 'Com1' ports, and power supply (5V/ 24V) of the Sahara and connect these to the relevant ports on a garage door opener. (As every automation device has its own port locations, this connection method will be shown to them through a wiring compatibility checker on the app and the website)

Step three

- Once installed, the end user is asked to power up their garage door opener and if the LED light on the Sahara turns on then power is now available on the device

Step four

- The end user will be asked to power the wireless DPS and then attach it to the inside of the garage door allowing the app to know the state of the garage

Step five

- This is an optional step for end users. If they have a 'request for exit' switch inside their garage they can connect this to the rex1 or rex2 ports and so then they can continue to open and close their garage through the switch

Garage Application.

Step one.

- Remove Sahara from the box.

Step two

- Download the Yale Access App.

Step 3

- Scan the QR code on the Sahara and wireless DPS device that will take you through the registration process of your device on the Yale Access app and add the device to WiFi.

Step 4

- Hardware installation should now take place. The End user will be taken through a step-by-step guide on the Yale access app on how to install their Sahara on a generic garage door opener (See hardware installation part to the right)

Step 5

- End user asked to test whether the device works after Sahara hardware installation is done

Step 6

- Now end users can use Sahara to open or close their garage door. (See example below).

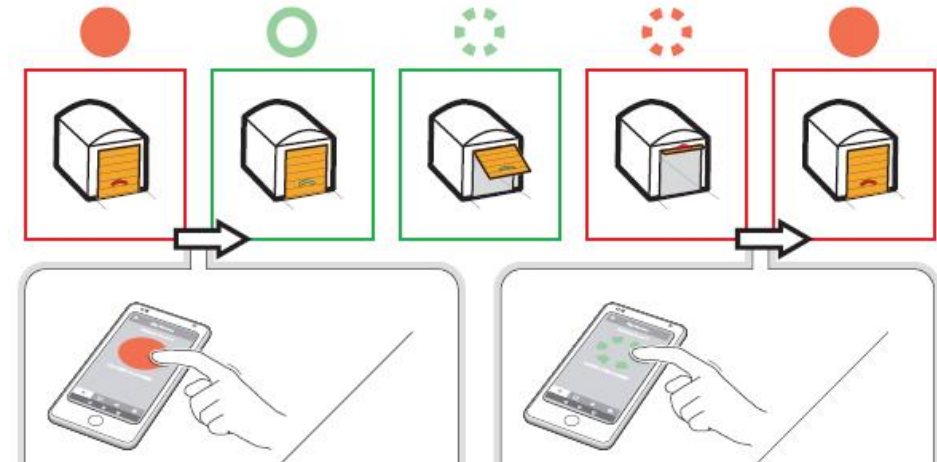

FCC-ISED Manual information

Attached is PDF with FCC and ISED Information to be added to the Manual.

FCC

This device complies with part 15 of the FCC Rules. Operation is subject to the following two conditions: (1) This device may not cause harmful interference, and (2) this device must accept any interference received, including interference that may cause undesired operation.

Any changes or modifications (including the antennas) to this device that are not expressly approved by the manufacturer may void the user's authority to operate the equipment.

Note: This equipment has been tested and found to comply with the limits for a Class B digital device, pursuant to part 15 of the FCC Rules. These limits are designed to provide reasonable protection against harmful interference in a residential installation. This equipment generates, uses and can radiate radio frequency energy and, if not installed and used in accordance with the instructions, may cause harmful interference to radio communications. However, there is no guarantee that interference will not occur in a particular installation. If this equipment does cause harmful interference to radio or television reception, which can be determined by turning the equipment off and on, the user is encouraged to try to correct the interference by one or more of the following measures:

- Reorient or relocate the receiving antenna.
- Increase the separation between the equipment and receiver.
- Connect the equipment into an outlet on a circuit different from that to which the receiver is connected.
- Consult the dealer or an experienced radio/TV technician for help.

Modifications not expressly approved by the manufacturer could void your authority to operate the equipment under FCC rules.

ISED

This device contains licence-exempt transmitter(s)/receiver(s) that comply with Innovation, Science and Economic Development Canada's licence-exempt RSS(s). Operation is subject to the following two conditions:

- (1) This device may not cause interference.
- (2) This device must accept any interference, including interference that may cause undesired operation of the device.

L'émetteur/récepteur exempt de licence contenu dans le présent appareil est conforme aux CNR d'Innovation, Sciences et Développement économique Canada applicables aux appareils radio exempts de licence. L'exploitation est autorisée aux deux conditions suivantes :

- (1) L'appareil ne doit pas produire de brouillage;
- (2) L'appareil doit accepter tout brouillage radioélectrique subi, même si le brouillage est susceptible d'en compromettre le fonctionnement.

RF Exposure Statement

FCC and IC RF Radiation Exposure Statement: This equipment complies with FCC and IC RF radiation exposure limits set forth for uncontrolled environments. This equipment should be installed and operated with a minimum distance of 20cm (may be adjusted according to actual calculation result) between the radiator and your body. This transmitter must not be co-located or operating in conjunction with any other antenna or transmitter.

RF du FCC et IC d'exposition aux radiations: Cet appareil est conforme aux limites d'exposition au rayonnement RF stipulées par le FCC et IC pour une utilisation dans un environnement non contrôlé. Les antennes utilisées pour cet émetteur doivent être installées et doivent fonctionner à au moins 20 cm de distance des utilisateurs et ne doivent pas être placées près d'autres antennes ou émetteurs ou fonctionner avec ceux-ci. Les installateurs doivent s'assurer qu'une distance de 20 cm sépare l'appareil (à l'exception du combiné) des utilisateurs.

FCC Warning

This device complies with part 15 of the FCC Rules.

Operation is subject to the following two conditions:

(1) This device may not cause harmful interference, and

(2) this device must accept any interference received, including interference that may cause undesired operation.

Any changes or modifications not expressly approved by the party responsible for compliance could void the user's authority to operate the equipment.

NOTE: This equipment has been tested and found to comply with the limits for a Class B digital device, pursuant to Part 15 of the FCC Rules.

These limits are designed to provide reasonable protection against harmful interference in a residential installation.

This equipment generates, uses and can radiate radio frequency energy and, if not installed and used in accordance with the instructions, may cause harmful interference to radio communications.

However, there is no guarantee that interference will not occur in a particular installation.

If this equipment does cause harmful interference to radio or television reception,

which can be determined by turning the equipment off and on, the user is encouraged to try to correct the interference by one or more of the following measures:

-- Reorient or relocate the receiving antenna.

-- Increase the separation between the equipment and receiver.

-- Connect the equipment into an outlet on a circuit different from that to which the receiver is connected.

-- Consult the dealer or an experienced radio/TV technician for help.

The device has been evaluated to meet general RF exposure requirement. The device can be used in portable exposure condition without restriction.

FCC ID: 2ABFG-IES-D320W-D0

IC Warning

RSS-Gen Issue 5 "&" RSS-Gen numéro 5

- English:

This device contains licence-exempt transmitter(s)/receiver(s) that comply with Innovation, Science and Economic Development Canada's licence-exempt RSS(s). Operation is subject to the following two conditions:

(1) This device may not cause interference.

(2) This device must accept any interference, including interference that may cause undesired operation of the device.

Any changes or modifications not expressly approved by the party responsible for compliance could void the user's authority to operate the equipment.

RF exposure statement:

The equipment complies with IC Radiation exposure limit set forth for uncontrolled environment. This equipment should be installed and operated with minimum distance 20cm between the radiator and your body.

- French:

Cet appareil contient des émetteurs / récepteurs exemptés de licence conformes aux RSS (RSS) d'Innovation, Sciences et Développement économique Canada. Le fonctionnement est soumis aux deux conditions suivantes:

(1) Cet appareil ne doit pas causer d'interférences.

(2) Cet appareil doit accepter toutes les interférences, y compris celles susceptibles de provoquer un fonctionnement indésirable de l'appareil.

Tout changement ou modification non expressément approuvé par la partie responsable de la conformité pourrait annuler l'autorité de l'utilisateur à utiliser l'équipement.

Déclaration d'exposition RF:

L'équipement est conforme à la limite d'exposition aux radiations de la IC établie pour un environnement non contrôlé. Cet équipement doit être installé et utilisé avec une distance minimale de 20cm entre le radiateur et votre corps.

IC:11626A-IESD320WDO



Thank you

assaabloy.com

Experience a safer and more open world

Internal

ASSA ABLOY