

# OpenBAS

BUILDING  
AUTOMATION  
SYSTEM

## OpenBAS-HV-WLSTH

Wired and Wireless Thermostat Transmitter

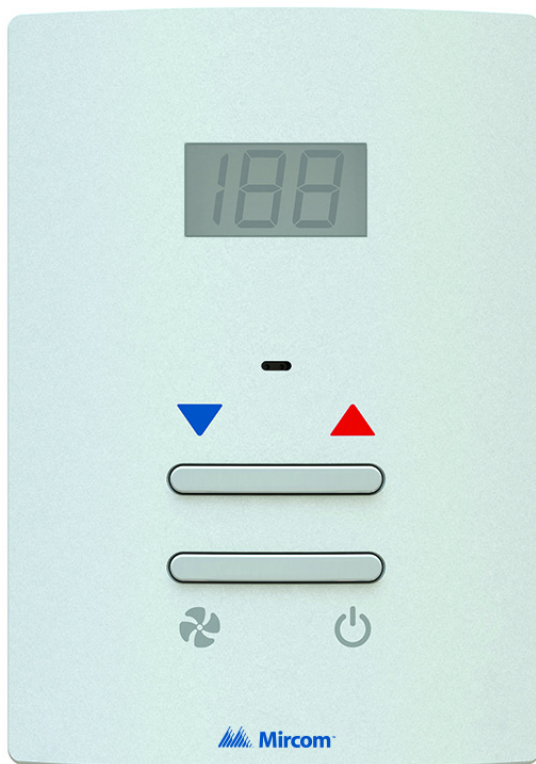



# Table of Contents

<b>1.0</b>	<b>Introduction</b>	<b>6</b>
1.1	OpenBAS-HV-WLSTH Wired and Wireless Thermostat Transmitter .....	6
1.2	Features .....	6
<b>2.0</b>	<b>Overview</b>	<b>7</b>
2.1	Components .....	7
2.1.1	Controllers .....	7
2.1.2	Compatible Modules .....	8
<b>3.0</b>	<b>Installation</b>	<b>9</b>
3.1	Parts of the Controller .....	9
3.2	Controller Board Connections .....	10
3.3	Batteries (OpenBAS-HV-WLSTH only) .....	10
3.4	Mounting Plate Dimensions .....	12
3.5	Mounting .....	12
<b>4.0</b>	<b>Field Wiring</b>	<b>13</b>
4.1	To Wire the Terminals .....	13
4.1.1	Required Tools .....	13
4.2	Power Supply Connection .....	14
4.3	Wireless Communication (OpenBAS-HV-WLSTH only) .....	15
4.4	RS-485 .....	16
4.4.1	RS-485 wiring requirements .....	16
4.5	Buttons .....	17
<b>5.0</b>	<b>Specifications</b>	<b>18</b>
<b>6.0</b>	<b>Master Warranty and Warning Information</b>	<b>19</b>
<b>7.0</b>	<b>Special Notices</b>	<b>24</b>
7.1	FCC Notice .....	24
7.2	RF Exposure Warning .....	24
7.3	RF Exposure Information .....	24

## List of Figures

Figure 1	Parts of the controller .....	<b>9</b>
Figure 2	Board connections .....	<b>10</b>
Figure 3	Battery connections .....	<b>11</b>
Figure 4	Mounting plate (back view) .....	<b>12</b>
Figure 5	Power supply - 12 VDC, 12 VAC, 24 VAC, 24 VDC .....	<b>14</b>
Figure 6	Wireless communication .....	<b>15</b>
Figure 7	Networking with RS-485 .....	<b>16</b>
Figure 8	Buttons .....	<b>17</b>

## List of Tables

Table 1	Controllers .....	<b>7</b>
Table 2	Compatible Modules .....	<b>8</b>

# 1.0 Introduction

This document provides information on installing the OpenBAS-HV-WLSTH wireless thermostat transmitter.

## 1.1 OpenBAS-HV-WLSTH Wired and Wireless Thermostat Transmitter

Mircom's OpenBAS-HV-WLSTH wireless temperature and humidity transmitter and thermostat works with the OpenBAS-HV-VAVFC receiver controller to provide an easy-to-set-up HVAC control for HVAC end unit applications such as: variable air volume (VAV) boxes, fan and coil units, mini split and water source chiller and heat pump units.

The OpenBAS-HV-WLSTH also connects to the receiver module OpenBAS-HV-RF433R to communicate with any OpenBAS-HV-NX10 series controller.

The OpenBAS-HV-WLSTH works in the 433 MHz unlicensed band to provide an RF link with a matched receiver up to 30 meters in line of sight applications and 15 meters indoors.

When used in wireless applications, it is powered by two AA alkaline batteries which provide between 12 and 18 months of operation, depending on the transmission rate.

It also comes standard with an integrated RS-485 port supporting multiple protocols.

It can be integrated into any network and used as a standard temperature and humidity transmitter or as a powerful yet easy to set environment HVAC controller.

It is fully addressable, and when used wirelessly it can be programmed into a group out of 10, and each group can have up to 199 individual addresses.

When used wired it can be given an address between 1 and 199 depending on the protocol.

## 1.2 Features

The OpenBAS-HV-WLSTH integrates into Mircom's unified platform for automating HVAC and mechanical rooms as well as incorporating energy management features and lighting control to offer building owners and managers a seamless operation with the following features:

- Modular design to cover small, medium or large projects.
- Industry standard Fieldbus protocols to integrate into any existing BAS system, such as BACnet, Modbus, Optomux, N2-Open, and ASCII.
- Connects to the NWK-ETH3 controller for integration into IP networks and uses the most advanced features and protocols such as distributed computing, USB and Cloud storage, HTML5, JavaScript, XML, Ajax, SMS, and GSM.
- Modular add-ons for every Building Automation System solution.
- The OpenBAS software which provides owners and managers a single solution for managing all their building's automation needs.

## 2.0 Overview

### 2.1 Components

#### 2.1.1 Controllers

Table 1 Controllers

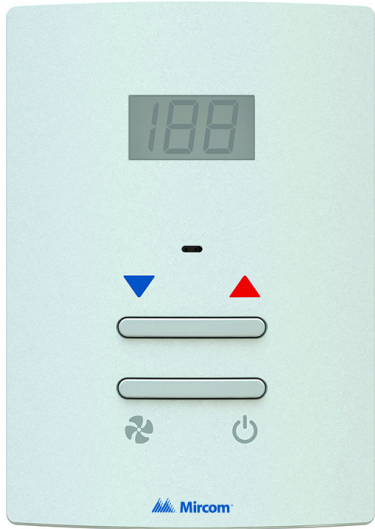
Picture	Model	Description
	OpenBAS-HV-WLSTH	Wireless and wired temperature and humidity transmitter and thermostat <ul style="list-style-type: none"> <li>• Operates on two AA alkaline batteries or an external power supply (12 V AC/DC to 24 V AC/DC)</li> <li>• Battery life is 12 to 18 months</li> <li>• 2 1/2 digit LCD display</li> <li>• four keyboard operator interface for setpoint and calibration setup.</li> <li>• Line of sight range of 30 meters and 15 meters indoors</li> <li>• 1 RS-485 bus</li> </ul>
	OpenBAS-HV-WRDT	Wired temperature transmitter and thermostat <ul style="list-style-type: none"> <li>• Operates on an external power supply (12 V AC/DC to 24 V AC/DC)</li> <li>• 2 1/2 digit LCD display</li> <li>• four keyboard operator interface for setpoint and calibration setup</li> <li>• 1 RS-485 bus</li> </ul> Minimum order: 100 units

## 2.1.2 Compatible Modules

Compatible modules are mounted separately from the controller.

**Table 2 Compatible Modules**

Model	Description
OpenBAS-HV-VAVFC	Wireless Fan & Coil or VAV controller for variable air volume (VAV) applications <ul style="list-style-type: none"> <li>• Wireless receiver for up to 10 temperature transmitters</li> <li>• Differential pressure sensor for pressure independent VAV applications</li> <li>• Two universal inputs</li> <li>• 5 digital outputs</li> <li>• Two analog outputs 0-10 VDC</li> <li>• Two Fieldbus connections with RS-485 driver</li> <li>• Can be set as master or slave</li> </ul>
OpenBAS-HV-FCX	Fan & Coil or VAV controller for variable air volume (VAV) applications <ul style="list-style-type: none"> <li>• Two universal inputs</li> <li>• 5 digital relay outputs</li> <li>• Two analog outputs</li> <li>• Two Fieldbus connections with RS-485 driver</li> <li>• Can be set up as master or slave</li> </ul> Minimum order: 100 units
OpenBAS-HV-VAVX	Fan & Coil or VAV controller for variable air volume (VAV) applications <ul style="list-style-type: none"> <li>• Two universal inputs</li> <li>• Two analog outputs</li> <li>• Two Fieldbus connections with RS-485 driver</li> <li>• Can be set up as master or slave</li> </ul> Minimum order: 100 units
OpenBAS-HV-RF433R (OpenBAS-HV-WLSTH only)	Wireless 433 MHz RF receiver that integrates up to 10 wireless transmitters and thermostats into OpenBAS-HV-NX series controllers through the I <sup>2</sup> C connection  Mounts in a DIN rail-mounted box



## 3.0 Installation



**Note:** Installation of OpenBAS controllers should be in accordance with the Canadian Electrical Code or the National Electrical Code, and comply with all local regulations. Final acceptance is subject to the Local Authority Having Jurisdiction (AHJ).

### 3.1 Parts of the Controller

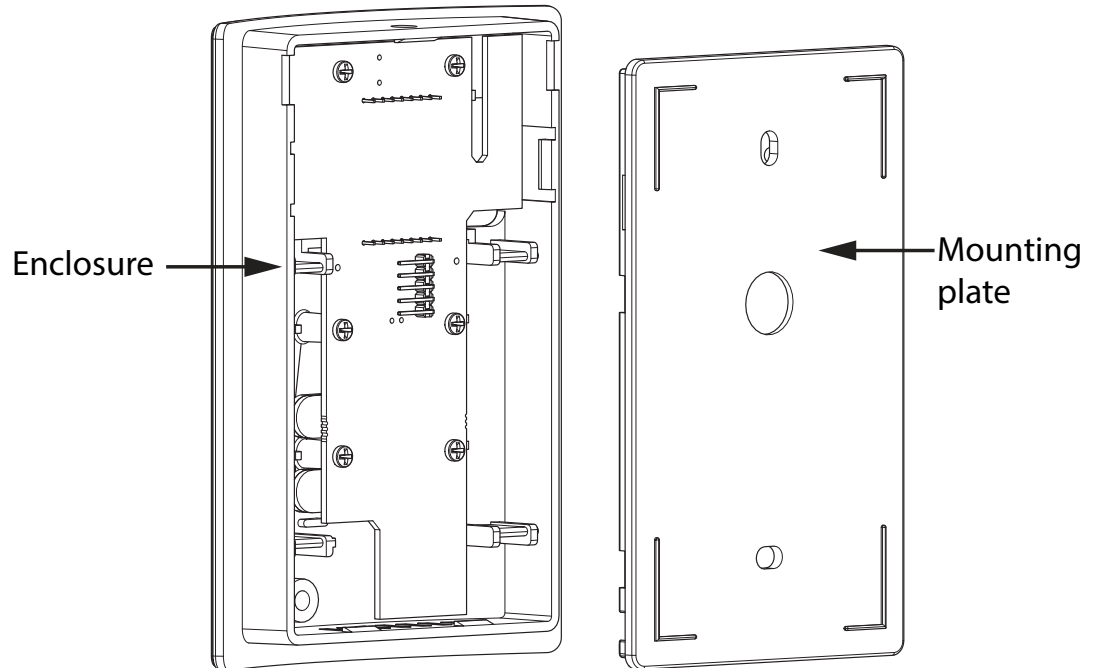

Figure 1 Parts of the controller

### 3.2 Controller Board Connections



**Attention:** Always disconnect the power before installing accessories.

See chapter 4 for instructions on connecting power and RS-485.

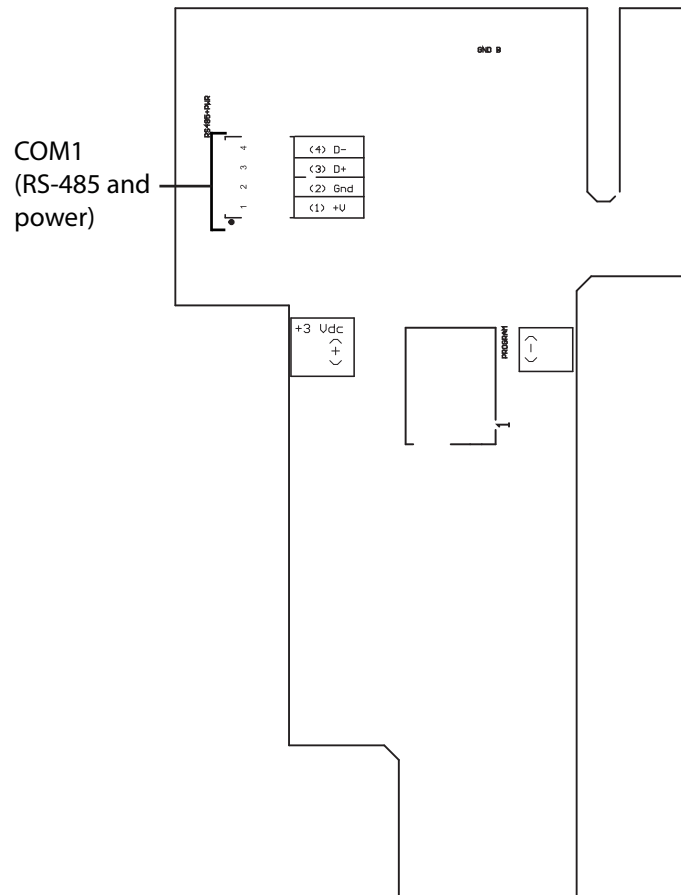

Figure 2 Board connections

### 3.3 Batteries (OpenBAS-HV-WLSTH only)



**Caution:** If you connect the controller to batteries, disconnect the power supply first. Do not use batteries and an external power supply at the same time.

OpenBAS-HV-WLSTH uses 2 AA alkaline 1.5 V batteries. Do not use nickel cadmium or lithium batteries.

Battery life is estimated at 12 to 18 months depending on operating conditions.

**To replace the batteries**

1. Disconnect the old batteries.
2. Dispose of the used batteries promptly. Keep away from children. Do not disassemble and do not dispose of in fire.
3. Connect the new batteries to the connectors shown in Figure 3. Pay attention to polarity.

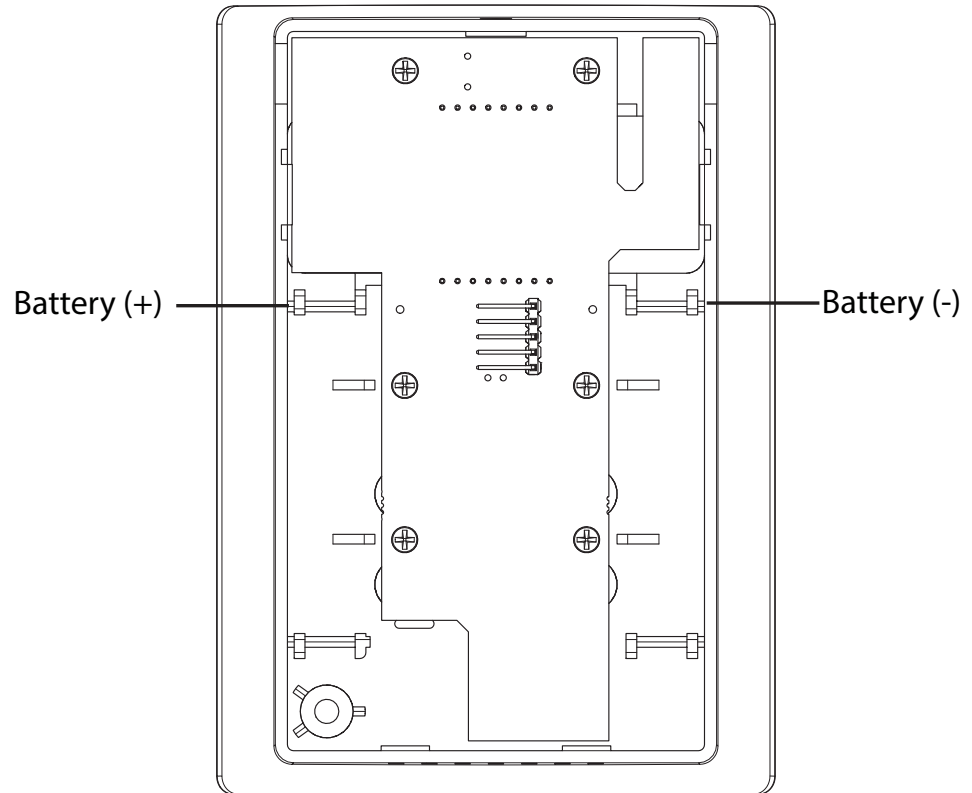

**Figure 3 Battery connections**

### 3.4 Mounting Plate Dimensions

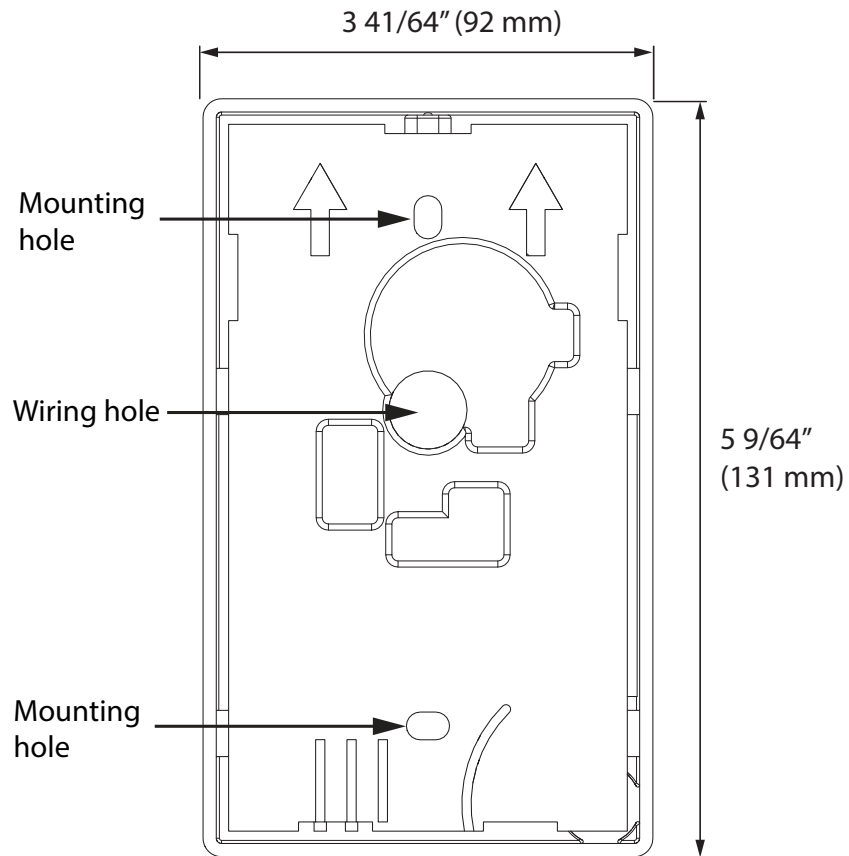

Figure 4 Mounting plate (back view)

### 3.5 Mounting

The controller mounts on the supplied mounting plate, which attaches to a standard single gang box.

**To mount the controller**

1. If you are connecting power or RS-485 to the controller, use AWG 22 to 24. Run the wires to the single gang box and then through the wiring hole on the mounting plate (see Figure 4).
2. Attach the mounting plate to the single gang box using two screws (see Figure 4).
3. Snap the controller on to the mounting plate.

## 4.0 Field Wiring



**Caution:** Installation of OpenBAS controllers must be in accordance with the Canadian Electrical Code or the National Electrical Code, and comply with all local regulations. Appropriate wiring and conduit should be used in compliance with local regulations. Final acceptance is subject to the Local Authority Having Jurisdiction (AHJ).

### 4.1 To Wire the Terminals

Figure 2 on page 10 shows the location of the terminals.

#### 4.1.1 Required Tools

- Micro screwdriver, bladed, size: 0.4 x 2.0 x 60 mm
- Wire cutter
- Wire stripper

#### To wire the terminals

- Insert the wire into the bottom round hole on the right side (the side with the labels).

#### To remove the wire

- Insert a micro screwdriver into the top hole to release the wire.

## 4.2 Power Supply Connection



**Caution:** If you connect the controller to a power supply, disconnect the batteries. Do not use batteries and an external power supply at the same time.

Use 22-24 AWG wires.

- 12 Vdc, 16.8 mA max.
- 12 Vac 50/60 Hz, 24 mA max.
- 24 Vac 50/60 Hz, 24 mA max.
- 24 Vdc 16.8 mA max.

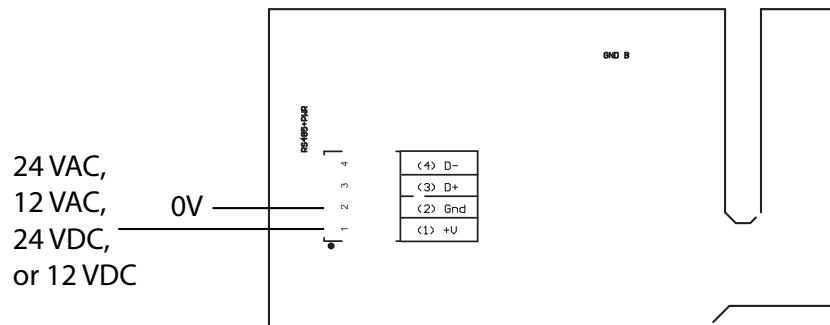

Figure 5 Power supply - 12 VDC, 12 VAC, 24 VAC, 24 VDC



**Caution:** An appropriate UL listed class 2 power supply or transformer with necessary protection devices such as fuses or breakers should be used to limit the risk of fire. All local codes and regulations for installation must be observed.

### 4.3 Wireless Communication (OpenBAS-HV-WLSTH only)

If you are using wireless communication only and not RS-485, you can power the unit either from an external power supply (section 4.2) or batteries (section 3.3 on page 10).

Multiple transmitters can be linked to a single receiver or to multiple receivers, depending on the application. A transmitter can send information to one or more receivers, and a receiver can receive information from up to ten different transmitters.

Each receiver (OpenBAS-HV-VAVFC or OpenBAS-HV-RF433R) is paired with up to 10 transmitters (OpenBAS-HV-WLSTH). In this way, the receiver can receive signals from some transmitters, and ignore signals from others, as shown in Figure 6.

- Maximum distance between transmitter and receiver: 15 m (49 ft) indoors, 30 m (98 ft) outdoors with line of sight

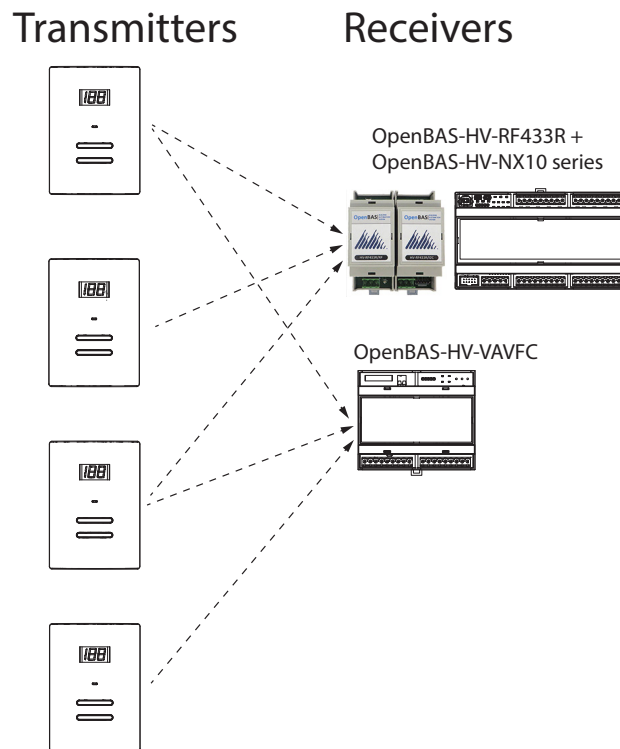

Figure 6 Wireless communication

## 4.4 RS-485

If you are using RS-485, then you cannot use batteries; you must use an external power supply. See section 4.2 on page 14.

Figure 7 shows OpenBAS-HV-WLSTH connected over wires for power and RS-485.



**Note:** Connect the RS-485 reference wire to the 0V or common of the VAV controller and the power supply.

### 4.4.1 RS-485 wiring requirements

- 22 AWG twisted pair
- Maximum length: 1219.2 m (4000 feet)
- Mircom recommends shielded cable

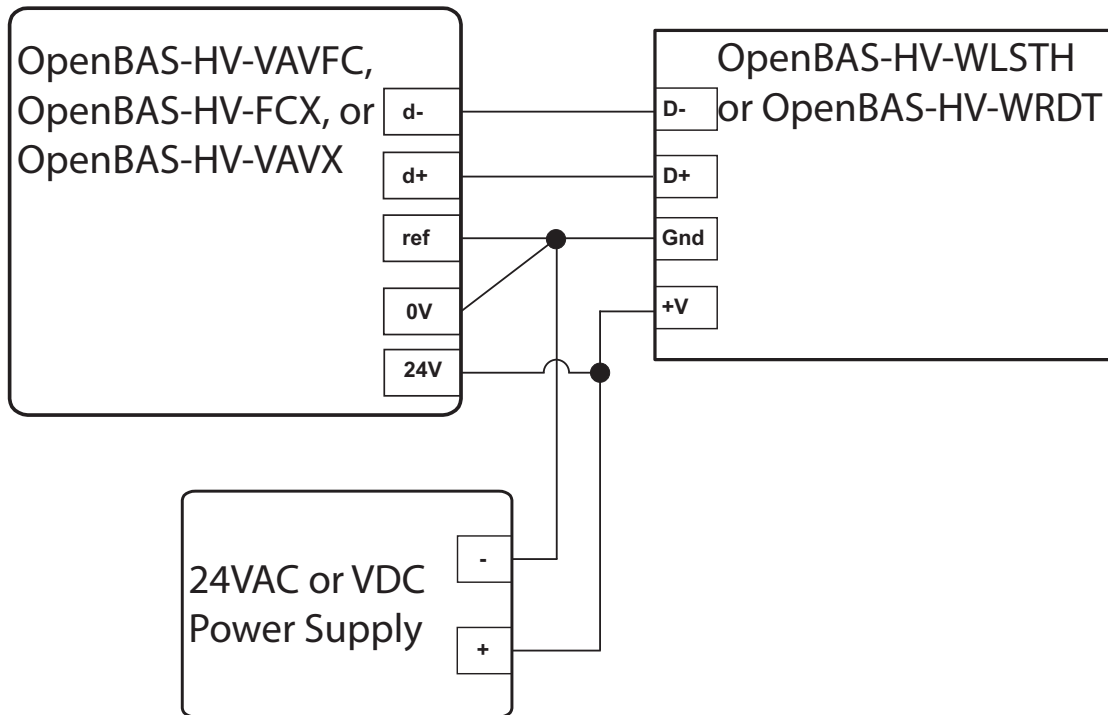
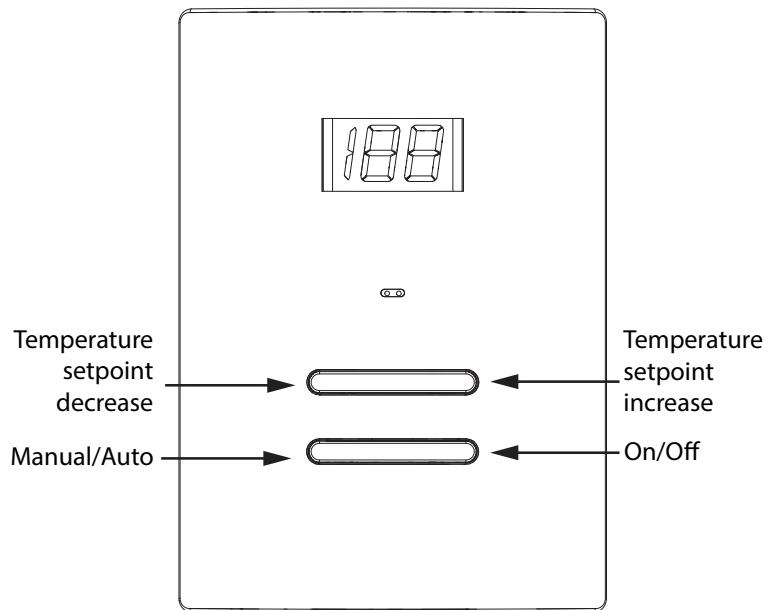

Figure 7 Networking with RS-485



## 4.5 Buttons

Figure 8 shows the buttons.



**Figure 8 Buttons**

- **Temperature setpoint decrease:** In automatic mode, press this button to decrease the temperature setpoint. In manual mode, press this button to decrease the fan speed.
- **Temperature setpoint increase:** In automatic mode, press this button to increase the temperature setpoint. In manual mode, press this button to increase the fan speed.
- **Manual/Auto:** This button switches between manual mode and automatic mode.
- **On/Off:** This button turns the HVAC equipment it controls on or off. If the control is off, the LCD display shows two hyphens on the screen. If the equipment is on, the screen shows either the current temperature if it is in automatic mode or the speed of the fan if it is in the manual mode.

## 5.0 Specifications

<b>Standards:</b>	UL 60730-1 FCC Part 15 / ICES-003, Class "B"
<b>Input:</b>	12 Vdc, 16.8 mA max., or 12 Vac 50/60 Hz, 24 mA max., or 24 Vac 50/60 Hz, 24 mA max., or 24 Vdc 16.8 mA max.  The power supply is required when using RS-485, or when using wireless communication without batteries  Do not use power supply and batteries at the same time
<b>Power Supply Protection:</b>	Non-replaceable, self-resetting fuse, 1 A
<b>Batteries (OpenBAS-HV-WLSTH only):</b>	2 AA alkaline 1.5 V batteries Battery life: 12 to 18 months  Do not use nickel cadmium or lithium batteries  Do not use batteries and power supply at the same time
<b>Wireless Characteristics (OpenBAS-HV-WLSTH only):</b>	Frequency: 433 MHz Range: 15 m (49 ft) indoors, 30 m (98 ft) outdoors with line of sight
<b>Communication Port:</b>	<b>1 RS-485 port supporting the following protocols:</b> <ul style="list-style-type: none"> <li>• BACnet/MSTP</li> <li>• Modbus/RTU-Slave</li> <li>• N2-Open</li> <li>• Optomux</li> <li>• ASCII</li> </ul>
<b>Physical Characteristics:</b>	Weight: 120 g (4.2 oz) Enclosure dimensions: 130 mm x 93 mm x 26 mm (5 1/8" x 3 21/32" x 1 1/32")
<b>Ambient Conditions:</b>	Operating: 0° to 40°C (32° to 104°F), 10% to 90% RH noncondensing Indoor Use Only
<b>Purpose of Control:</b>	Thermostat
<b>Construction of Control:</b>	Independently Mounted
<b>Action Type and additional features:</b>	Type 1
<b>Pollution Degree:</b>	2
<b>Software Class:</b>	Class A

## 6.0 Master Warranty and Warning Information

### Terms & Interpretation

In this document the term **MGC System** refers to all fire alarm, nurse call, and building automation products manufactured by Mircom Group of Companies, Mircom Technologies Ltd., MGC Systems Corp or subsidiaries and affiliates and includes specific systems such as MiCare™, OpenBAS™, and FlexNet™. Moreover, the term **MGC System** extends to cover all component parts and software used within such products.

### Warning Please Read Carefully

All **MGC Systems** are subject to terms and conditions of sale as follows:

### Note to Installers

This warning contains vital information. As the only individual in contact with system users, it is your responsibility to bring each item in this warning to the attention of the users of this MGC System. Failure to properly inform system end-users of the circumstances in which the system might fail may result in over-reliance upon the system. As a result, it is imperative that you properly inform each customer for whom you install the system of the possible forms of failure.

### System Failures

All **MGC Systems** have been carefully designed to be as effective as possible. However, there are circumstances where they may not provide protection. Some reasons for system failure include:

#### *Inadequate Installation*

All **MGC Systems** must be installed in accordance with all the applicable codes and standards in order to provide adequate protection. National standards require an inspection and approval to be conducted by the Local Authority Having Jurisdiction following the initial installation of the system and following any changes to the system. Such inspections ensure installation has been carried out properly.

#### *Inadequate Testing*

Most problems that would prevent an alarm a **MGC System** from operating as intended can be discovered by regular testing and maintenance. The complete system should be tested by the Local Authority Having Jurisdiction immediately after a fire, storm, earthquake, accident, or any kind of construction activity inside or outside the premises. The testing should include all sensing devices, keypads, consoles, alarm indicating devices and any other operational devices that are part of the system.

**IMPORTANT NOTE:** End-users of the system must take care to ensure that the system, batteries, telephone lines, etc. are tested and examined on a regular basis to minimize system failure.

### ***System Users***

It is important that all system users be trained in the correct operation of the alarm system and that they know how to respond when the system indicates an alarm.

A **MGC System** may not function as intended during an emergency situation where the user is unable to operate a panic or emergency switch by reason of permanent or temporary physical disability, inability to reach the device in time, unfamiliarity with the correct operation, or related circumstances.

### ***Insufficient Time***

There may be circumstances when a **MGC System** will operate as intended, yet the occupants will not be protected from the emergency due to their inability to respond to the warnings in a timely manner. If the system is monitored, the response may not occur in time enough to protect the occupants or their belongings.

Moreover, smoke detectors may not provide timely warning of fires caused by carelessness or safety hazards such as smoking in bed, violent explosions, escaping gas, improper storage of flammable materials, overloaded electrical circuits, children playing with matches or arson.

### ***Power Failure***

Some **MGC System** components require adequate electrical power supply to operate. Examples include: smoke detectors, beacons, HVAC, and lighting controllers. If a device operates only by AC power, any interruption, however brief, will render that device inoperative while it does not have power. Power interruptions of any length are often accompanied by voltage fluctuations which may damage **MGC Systems** or other electronic equipment. After a power interruption has occurred, immediately conduct a complete system test to ensure that the system operates as intended.

### ***Battery Failure***

If the **MGC System** or any device connected to the system operates from batteries it is possible for the batteries to fail. Even if the batteries have not failed, they must be fully charged, in good condition, and installed correctly.

**MGC Systems** with wireless transmitters use replaceable batteries. The system is designed to provide several years of battery life under normal conditions. The expected battery life is a function of the device environment, usage and type. Ambient conditions such as high humidity, high or low temperatures, or large temperature fluctuations may reduce the expected battery life. While each transmitting device has a low battery monitor which identifies when the batteries need to be replaced, this monitor may fail to operate as expected. Regular testing and maintenance will keep the system in good operating condition.

### ***Physical Obstructions***

Motion sensors that are part of a **MGC System** must be kept clear of any obstacles which impede the sensors' ability to detect movement. Signals being communicated by a **MGC System** may not reach the receiver if an item (such as metal, water, or concrete) is placed on or near the radio path. Deliberate jamming or other inadvertent radio signal interference can also negatively affect system operation.

Moreover, **MGC Systems** may fail to operate as intended if motion, heat, or smoke sensors are not triggered. Sensors in a fire system may fail to be triggered when the fire is in a chimney, walls, roof, or on the other side of closed doors; and, smoke and heat detectors may

not detect smoke or heat from fires on another level of the residence or building. In this situation the control panel may not alert occupants of a fire.

Sensors in a nurse call system may fail to be triggered when movement is occurring outside of the motion sensors' range. For example, if movement is occurring on the other side of closed doors or on another level of the residence or building the motion detector may not be triggered. In this situation the central controller may not register an alarm signal.

### ***Other Impairments***

Similarly, Alarm Notification Appliances such as sirens, bells, horns, or strobes may not warn or waken a sleeping occupant if there is an intervening wall or door. It is less likely that the occupants will be alerted or awakened when notification appliances are located on a different level of the residence or premise.

Audible notification appliances may be interfered with by other noise sources such as stereos, radios, televisions, air conditioners, appliances, or passing traffic. Audible notification appliances, however loud, may not be heard by a hearing-impaired person.

### ***Software***

Most **MGC Systems** contain software. With respect to those products, MGC does not warrant that the operation of the software will be uninterrupted or error-free or that the software will meet any other standard of performance, or that the functions or performance of the software will meet the user's requirements. MGC shall not be liable for any delays, breakdowns, interruptions, loss, destruction, alteration or other problems in the use of a product arising out of, or caused by, the software.

### ***Telephone Lines***

Telephone service can cause system failure where telephone lines are relied upon by a **MGC System**. Alarms and information coming from an **MGC System** may not be transmitted if a phone line is out of service or busy for a certain period of time. Alarms and information may not be transmitted where telephone lines have been compromised by criminal tampering, local construction, storms or earthquakes.

### ***Component Failure***

Although every effort has been made to make this **MGC System** as reliable as possible, the system may fail to function as intended due to the failure of a component.

### ***Security and Insurance***

Regardless of its capabilities, no **MGC System** is a substitute for property or life insurance. Nor is the system a substitute for property owners, renters, or other occupants to act prudently to prevent or minimize the harmful effects of an emergency situation.

Moreover, building automation systems produced by MGC are not to be used as a fire, alarm, or life safety systems.

## Warranty

### Limited Warranty

Mircom Technologies Ltd., MGC Systems Corp. and MGC System International Ltd. together with their subsidiaries and affiliates (collectively, MGC) warrants the original purchaser that for a period of three years from the date of manufacture, proprietary manufactured product shall be free of defects in materials and workmanship, under normal use. During the warranty period, MGC shall, at its option, repair or replace any defective product upon return of the product to its factory, at no charge for labor and materials. **Non-proprietary, third party or OEM product shall be warranted in accordance with the warranty period of the manufacturer. Any replacement and/or repaired parts are warranted for the remainder of the original warranty or ninety (90) days, whichever is longer.** The original owner must promptly notify MGC in writing that there is defect in material or workmanship, such written notice to be received in all events prior to expiration of the warranty period.

### International Warranty

The warranty for international customers is the same as for any customer within Canada and the United States, MGC shall not be responsible for any customs fees, taxes, or VAT that may be due.

### Conditions to Void Warranty

This warranty applies only to defects in parts and workmanship relating to normal use. It does not cover:

- damage incurred in shipping or handling;
- damage caused by disaster such as fire, flood, wind, earthquake or lightning;
- damage due to causes beyond the control of MGC such as excessive voltage, mechanical shock or water damage;
- damage caused by unauthorized attachment, alterations, modifications or foreign objects;
- damage caused by peripherals (unless such peripherals were supplied by MGC);
- defects caused by failure to provide a suitable installation environment for the products;
- damage caused by use of the products for purposes other than those for which it was designed;
- damage from improper maintenance;
- damage arising out of any other abuse, mishandling or improper application of the products.

### Warranty Procedure

To obtain service under this warranty, please return the item(s) in question to the point of purchase. All authorized distributors and dealers have a warranty program. Anyone returning goods to MGC must first obtain an authorization number. MGC will not accept any shipment whatsoever for which prior authorization has not been obtained. NOTE: Unless specific pre-authorization in writing is obtained from MGC management, no credits will be issued for custom fabricated products or parts or for complete fire alarm system. MGC will at its sole option, repair or replace parts under warranty. Advance replacements for such items must be purchased.

Note: MGC's liability for failure to repair the product under this warranty after a reasonable number of attempts will be limited to a replacement of the product, as the exclusive remedy for breach of warranty.

## Disclaimer of Warranties

This warranty contains the entire warranty and shall be in lieu of any and all other warranties, whether expressed or implied (including all implied warranties of merchantability or fitness for a particular purpose) and of all other obligations or liabilities. MGC neither assumes nor authorizes any other person purporting to act on its behalf to modify or to change this warranty, or to assume for it any other warranty or liability concerning this product.

This disclaimer of warranties and limited warranty are governed by the laws of the province of Ontario, Canada.

## Out of Warranty Repairs

MGC will at its option repair or replace out-of-warranty products which are returned to its factory according to the following conditions. Anyone returning goods to MGC must first obtain an authorization number. MGC will not accept any shipment whatsoever for which prior authorization has not been obtained.

Products which MGC determines to be repairable will be repaired and returned. A set fee which MGC has predetermined and which may be revised from time to time, will be charged for each unit repaired.

Products which MGC determines not to be repairable will be replaced by the nearest equivalent product available at that time. The current market price of the replacement product will be charged for each replacement unit.

The foregoing information is accurate as of the date of publishing and is subject to change or revision without prior notice at the sole discretion of the Company.

WARNING: MGC recommends that the entire system be completely tested on a regular basis. However, despite frequent testing, and due to, but not limited to, criminal tampering or electrical disruption, it is possible for this product to fail to perform as expected.

**NOTE: UNDER NO CIRCUMSTANCES SHALL MGC BE LIABLE FOR ANY SPECIAL, INCIDENTAL, OR CONSEQUENTIAL DAMAGES BASED UPON BREACH OF WARRANTY, BREACH OF CONTRACT, NEGLIGENCE, STRICT LIABILITY, OR ANY OTHER LEGAL THEORY. SUCH DAMAGES INCLUDE, BUT ARE NOT LIMITED TO, LOSS OF PROFITS, LOSS OF THE PRODUCT OR ANY ASSOCIATED EQUIPMENT, COST OF CAPITAL, COST OF SUBSTITUTE OR REPLACEMENT EQUIPMENT, FACILITIES OR SERVICES, DOWN TIME, PURCHASER'S TIME, THE CLAIMS OF THIRD PARTIES, INCLUDING CUSTOMERS, AND INJURY TO PROPERTY.**

MGC MAKES NO WARRANTY OF MERCHANTABILITY OR FITNESS FOR A PARTICULAR PURPOSE WITH RESPECT TO ITS GOODS DELIVERED, NOR IS THERE ANY OTHER WARRANTY, EXPRESSED OR IMPLIED, EXCEPT FOR THE WARRANTY CONTAINED HEREIN.

## 7.0 Special Notices

### 7.1 FCC and IC Regulatory Statements

FCC ID: 2ABFD-9246AE80D86

IC ID: 1156A-DF9DBB57B1

This device complies with Part 15 / ICES-003 of the FCC / Industry Canada Rules.

Operation is subject to the following two conditions:

- (1) This device may not cause harmful interference, and
- (2) This device must accept any interference received, including interference that may cause undesired operation.

Cet appareil est conforme à la partie 15 du FCC et à la norme NMB-003 /ICES-003 d'Industrie Canada.

Son fonctionnement est sujet aux deux conditions suivantes:

- (1) le dispositif ne doit pas produire de brouillage préjudiciable, et
- (2) ce dispositif doit accepter tout brouillage reçu, y compris un brouillage susceptible de provoquer un fonctionnement indésirable.

### 7.2 RF Exposure Warning

This equipment complies with FCC radiation exposure limits set forth for an uncontrolled environment. In order to avoid the possibility of exceeding the FCC radio frequency exposure limits, human proximity to the antenna shall not be less than 20 cm during normal operation and must not be co-located or operating in conjunction with any other antenna or transmitter.

### 7.3 RF Exposure Information

This equipment complies with ISED RSS-102 radiation exposure limits set forth for an uncontrolled environment. This transmitter must be installed to provide a separation distance of at least 20 cm from all persons and must not be co-located or operating in conjunction with any other antenna or transmitter.

Cet équipement est conforme avec ISED RSS-102 des limites d'exposition aux rayonnements définies pour un environnement non contrôlé. Cet émetteur doit être installé à au moins 20 cm de toute personne et ne doit pas être colocalisé ou fonctionner en association avec une autre antenne ou émetteur.





**CANADA - Main Office**  
25 Interchange Way  
Vaughan, ON L4K 5W3  
Tel: (888) 660-4655  
(905) 660-4655  
Fax: (905) 660-4113

**U.S.A**  
4575 Witmer Industrial Estates  
Niagara Falls, NY 14305  
Tel: (888) 660-4655  
(905) 660-4655  
Fax: (905) 660-4113

**TECHNICAL SUPPORT**  
North America  
Tel: (888) Mircom5  
(888) 647-2665  
International  
Tel: (905) 647-2665

© Mircom 2017  
Printed in Canada  
Subject to change without prior notice

[www.mircomgroup.com](http://www.mircomgroup.com)