

FCC Radio Test Report

FCC ID: 2ABES-GURUBOOK5

Original Grant

Report No. : TB-FCC140201
Applicant : Pathway Innovations and Technologies, Inc.
Equipment Under Test (EUT)
EUT Name : Gurubook 5/MID
Model No. : Gurubook 5
Series Model No. : Gurubook 8, Gurubook 12, Gurubook 13, Gurubook 16
Brand Name : HoverCam
Receipt Date : 2014-08-18
Test Date : 2014-08-19 to 2014-09-05
Issue Date : 2014-09-10
Standards : FCC Part 15, Subpart C (15.247:2013)
Test Method : ANSI C63.4:2003
Conclusions : **PASS**

In the configuration tested, the EUT complied with the standards specified above,

The EUT technically complies with the FCC and IC requirements

Test/Witness Engineer :

IVAN SU

Approved & Authorized :

Ray

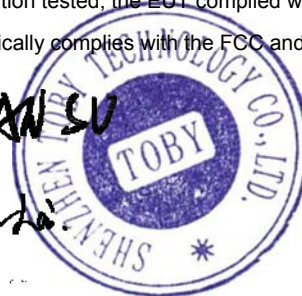

This report details the results of the testing carried out on one sample. The results contained in this test report do not relate to other samples of the same product. The manufacturer should ensure that all products in series production are in conformity with the product sample detailed in the report.

Contents

CONTENTS.....	2
1. GENERAL INFORMATION ABOUT EUT	4
1.1 Client Information.....	4
1.2 General Description of EUT (Equipment Under Test)	4
1.3 Block Diagram Showing the Configuration of System Tested.....	5
1.4 Description of Support Units	5
1.5 Description of Test Mode.....	6
1.6 Description of Test Software Setting	6
1.7 Test Facility.....	7
2. TEST SUMMARY	8
3. CONDUCTED EMISSION TEST	9
3.1 Test Standard and Limit.....	9
3.2 Test Setup.....	9
3.3 Test Procedure.....	9
3.4 Test Equipment Used.....	10
3.5 EUT Operating Mode	10
3.6 Test Data.....	10
4. RADIATED EMISSION TEST	14
4.1 Test Standard and Limit.....	14
4.2 Test Setup.....	15
4.3 Test Procedure.....	16
4.4 EUT Operating Condition	16
4.5 Test Equipment	17
4.6 Test Data.....	17
5. RESTRICTED BANDS REQUIREMENT	44
5.1 Test Standard and Limit.....	44
5.2 Test Setup.....	44
5.3 Test Procedure.....	44
5.4 EUT Operating Condition	45
5.5 Test Equipment	45
5.6 Test Data.....	45
6. BANDWIDTH TEST	66
6.1 Test Standard and Limit.....	66
6.2 Test Setup.....	66
6.3 Test Procedure.....	66
6.4 EUT Operating Condition	66
6.5 Test Equipment	66
6.6 Test Data.....	67
7. PEAK OUTPUT POWER TEST.....	75

7.1 Test Standard and Limit.....	75
7.2 Test Setup.....	75
7.3 Test Procedure.....	75
7.4 EUT Operating Condition	75
7.5 Test Equipment.....	75
7.6 Test Data.....	75
8. POWER SPECTRAL DENSITY TEST	77
8.1 Test Standard and Limit.....	77
8.2 Test Setup.....	77
8.3 Test Procedure.....	77
8.4 EUT Operating Condition	77
8.5 Test Equipment.....	78
8.6 Test Data.....	78
9. ANTENNA REQUIREMENT.....	86
9.1 Standard Requirement.....	86
9.2 Antenna Connected Construction	86
9.3 Result.....	86

1. General Information about EUT

1.1 Client Information

Applicant : Pathway Innovations and Technologies, Inc.
Address : 9833 Pacific Heights Blvd., Suite D, San Diego, CA 92121
Manufacturer : ShenZhen KerunVisual Technology Co., LTD.
Address : 6th Floor Building 2, District 2, South Honghualing Industrial Zone, No.1213 Liuxian Road, Nanshan Branch, Shenzhen City, Guangdong, China

1.2 General Description of EUT (Equipment Under Test)

EUT Name	:	Gurubook 5/MID
Models No.	:	Gurubook 5, Gurubook 8, Gurubook 12, Gurubook 13, Gurubook 16
Model Difference	:	All the other models are identical in the same PCB layout, interior structure and electrical circuits, The only difference is model name for commercial purpose.
Product Description	:	Operation Frequency: 802.11b/g/n(HT20): 2412MHz~2462MHz 802.11b/g/n(HT40): 2422MHz~2452MHz
	:	Number of Channel: 802.11b/g/n(HT20):11 channels <i>see note(3)</i> 802.11b/g/n(HT40): 7 channels <i>see note(3)</i>
	:	RF Output Power: 802.11b: 9.80 dBm 802.11g: 9.46 dBm 802.11n (HT20): 9.36 dBm 802.11n (HT40): 8.30 dBm
	:	Antenna Gain: 0 dBi (FPC Antenna)
	:	Modulation Type: 802.11b: DSSS (CCK, QPSK, BPSK) 802.11g: OFDM 802.11n: OFDM
	:	Bit Rate of Transmitter: 802.11b:11/5.5/2/1 Mbps 802.11g:54/48/36/24/18/12/9/6 Mbps 802.11n:up to 150Mbps
Power Supply	:	DC power supplied by AC/DC Adapter DC Voltage supplied from Li-Polymer battery.
Power Rating	:	AC/DC Adapter: Input: AC 100~240V 50/60Hz 0.35A Output: DC 5V 2A DC 3.7V 2800mAh from Li-ion battery
Connecting I/O Port(S)	:	The equipent have USB port for link with PC. Please refer to the User's Manual
Note: The equipment with Bluetooth and Wifi(802.11b/g/n) function, Bluetooth have test comply with		

FCC Part 15C Rules. More detailed features description, please refer to the manufacturer's specifications or the User's Manual.

Note:

- (1) This Test Report is FCC Part 15.247 for 802.11b/g/n, the test procedure follows the FCC KDB 558074 D01 DTS Meas Guidance v03r02.
- (2) For a more detailed features description, please refer to the manufacturer's specifications or the User's Manual.
- (3) Antenna information provided by the applicant.
- (4) Channel List:
 CH 01~CH 11 for 802.11b/g/n(HT20)
 CH 03~CH 09 for 802.11b/g/n(HT40)

Channel	Frequency (MHz)	Channel	Frequency (MHz)	Channel	Frequency (MHz)
01	2412	05	2432	09	2452
02	2417	06	2437	10	2457
03	2422	07	2442	11	2462
04	2427	08	2447		

1.3 Block Diagram Showing the Configuration of System Tested

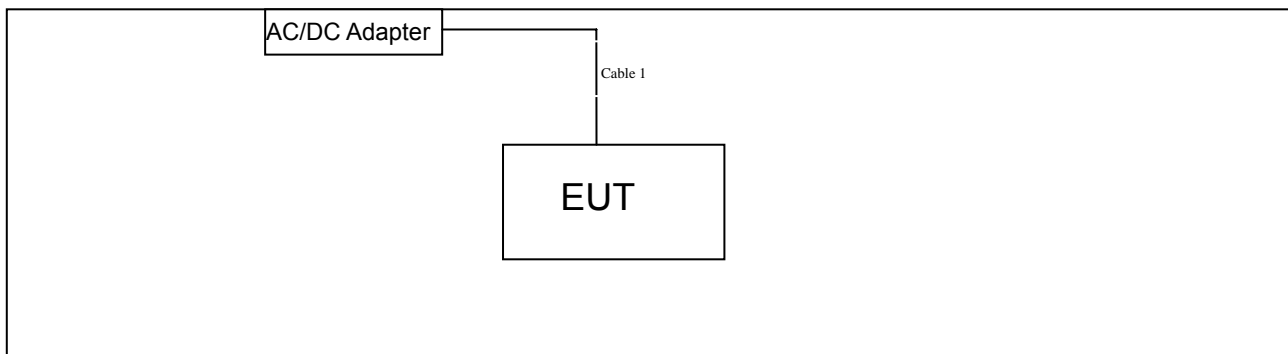
TX Mode

1.4 Description of Support Units

Equipment Information				
Name	Model	S/N	Manufacturer	Used "√"
/	/	/	/	/
Cable Information				
Number	Shielded Type	Ferrite Core	Length	Note
Cable 1	NO	NO	1.0M	Accessories

1.5 Description of Test Mode

To investigate the maximum EMI emission characteristics generates from EUT, the test system was pre-scanning tested base on the consideration of following EUT operation mode or test configuration mode which possible have effect on EMI emission level. Each of these EUT operation mode(s) or test configuration mode(s) mentioned follow was evaluated respectively.

For Conducted Test	
Final Test Mode	Description
Mode 1	AC Charging with TX B Mode

For Radiated Test	
Final Test Mode	Description
Mode 3	TX Mode B Mode Channel 01/06/11
Mode 4	TX Mode G Mode Channel 01/06/11
Mode 5	TX Mode N(HT20) Mode Channel 01/06/11
Mode 6	TX Mode N(HT40) Mode Channel 01/06/11

Note:

- (1) For all test, we have verified the construction and function in typical operation. And all the test modes were carried out with the EUT in transmitting operation in maximum power with all kinds of data rate.
According to ANSI C63.4 standards, the measurements are performed at the highest, middle, lowest available channels, and the worst case data rate as follows:
 - 802.11b Mode: CCK (1 Mbps)
 - 802.11g Mode: OFDM (6 Mbps)
 - 802.11n (HT20) Mode: MCS 0 (6.5 Mbps)
 - 802.11n (HT40) Mode: MCS 0 (13 Mbps)
- (2) During the testing procedure, the continuously transmitting with the maximum power mode was programmed by the customer.
- (3) The EUT is considered a mobile unit; in normal use it was positioned on X-plane. The worst case was found positioned on X-plane. Therefore only the test data of this X-plane was used for radiated emission measurement test.

1.6 Description of Test Software Setting

During testing channel& Power controlling software provided by the customer was used to control the operating channel as well as the output power level. The RF output power selection is for the setting of RF output power expected by the customer and is going to be fixed on the firmware of the final end product power parameters of WLAN.

Test Software Version	Test Program: Mediatek Connectivity Combo Tool v1.5.apk		
Channel	CH 01	CH 06	CH 11
IEEE 802.11b DSSS	DEF	DEF	DEF
IEEE 802.11g OFDM	DEF	DEF	DEF
IEEE 802.11n (HT20)	DEF	DEF	DEF
Channel	CH 03	CH 06	CH 09
IEEE 802.11n (HT40)	DEF	DEF	DEF

1.7 Test Facility

The testing was performed by the Shenzhen Toby Technology Co., Ltd., in their facilities located at:

1A/F., Bldg.6, Yusheng Industrial Zone, The National Road No.107 Xixiang Section 467, Xixiang, Bao'an, Shenzhen, Guangdong, China.

At the time of testing, the following bodies accredited the Laboratory:

CNAS (L5813)

The Laboratory has been accredited by CNAS to ISO/IEC 17025: 2005 General Requirements for the Competence of Testing and Calibration Laboratories for the competence in the field of testing. And the Registration No.: CNAS L5813.

FCC List No.: (811562)

The Laboratory is listed in the United States of American Federal Communications Commission (FCC), and the registration number is 811562.

IC Registration No.: (11950A-1)

The Laboratory has been registered by Certification and Engineering Bureau of Industry Canada for radio equipment testing. The site registration: Site# 11950A-1.

2. Test Summary

FCC Part 15 Subpart C(15.247)/RSS-210: 2010				
Standard Section		Test Item	Judgment	Remark
FCC	IC			
15.203	/	Antenna Requirement	PASS	N/A
15.207	RSS-GEN 7.2.4	Conducted Emission	PASS	N/A
15.205	RSS-GEN 7.2.2	Restricted Bands	PASS	N/A
15.247(a)(2)	RSS-210 A.8.2(a)	6dB Bandwidth	PASS	N/A
15.247(b)	RSS-210 A.8.4(4)	Peak Output Power	PASS	N/A
15.247(e)	RSS-210 A.8.2(b)	Power Spectral Density	PASS	N/A
15.247(d)	RSS-210 Annex 8 (A8.5)	Transmitter Radiated Spurious Emission	PASS	N/A
15.247(d)	RSS-210 Annex 8 (A8.5)	Antenna Conducted Spurious Emission	PASS	N/A

Note: "/" for no requirement for this test item.
N/A is an abbreviation for Not Applicable.

3. Conducted Emission Test

3.1 Test Standard and Limit

3.1.1 Test Standard

FCC Part 15.207

3.1.2 Test Limit

Conducted Emission Test Limit

Frequency	Maximum RF Line Voltage (dB μ V)	
	Quasi-peak Level	Average Level
150kHz~500kHz	66 ~ 56 *	56 ~ 46 *
500kHz~5MHz	56	46
5MHz~30MHz	60	50

Notes:

- (1) *Decreasing linearly with logarithm of the frequency.
- (2) The lower limit shall apply at the transition frequencies.
- (3) The limit decrease in line with the logarithm of the frequency in the range of 0.15 to 0.50MHz.

3.2 Test Setup

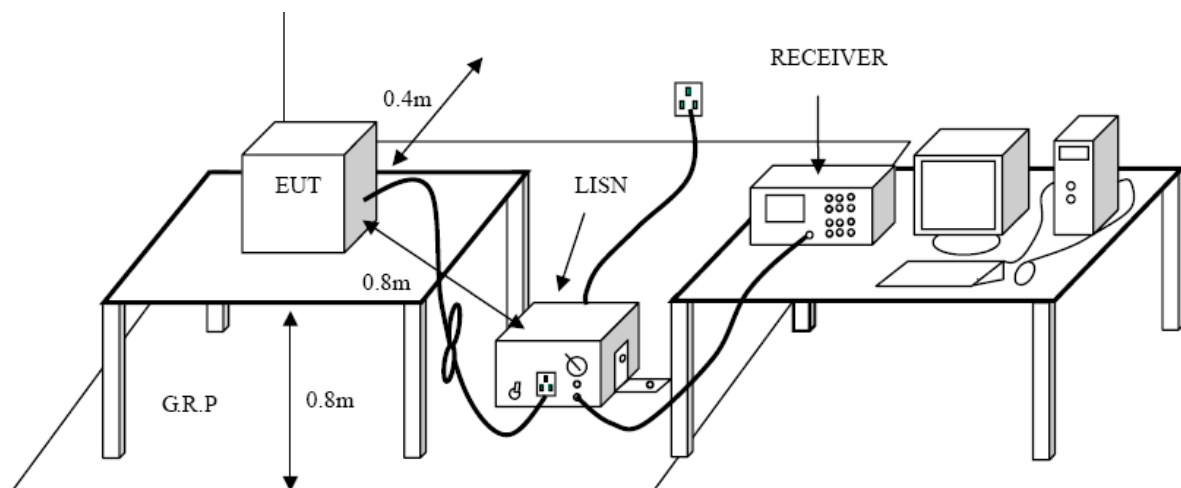

3.3 Test Procedure

The EUT was placed 0.8 meters from the horizontal ground plane with EUT being connected to the power mains through a line impedance stabilization network (LISN). All other support equipments powered from additional LISN(s). The LISN provide 50 Ohm/ 50uH of coupling impedance for the measuring instrument.

Interconnecting cables that hang closer than 40 cm to the ground plane shall be folded back and forth in the center forming a bundle 30 to 40 cm long.

I/O cables that are not connected to a peripheral shall be bundled in the center. The end of the cable may be terminated, if required, using the correct terminating impedance. The overall length shall not exceed 1 m.

LISN at least 80 cm from nearest part of EUT chassis.

The bandwidth of EMI test receiver is set at 9kHz, and the test frequency band is from 0.15MHz to 30MHz.

3.4 Test Equipment Used

Description	Manufacturer	Model No.	Serial No.	Cal. Date	Cal. Due Date
EMI Test Receiver	ROHDE& SCHWARZ	ESCI	100321	Aug. 08, 2014	Aug. 07, 2015
50Ω Coaxial Switch	Anritsu	MP59B	X10321	Aug. 08, 2014	Aug. 07, 2015
L.I.S.N	Rohde & Schwarz	ENV216	101131	Aug. 08, 2014	Aug. 07, 2015
L.I.S.N	SCHWARZBECK	NNBL 8226-2	8226-2/164	Aug. 08, 2014	Aug. 07, 2015

3.5 EUT Operating Mode

Please refer to the description of test mode.

3.6 Test Data

Please see the next page.

EUT:	Gurubook 5/MID	Model Name :	GURUBOOK5
Temperature:	25 °C	Relative Humidity:	55%
Test Voltage:	AC 120V/60 Hz		
Terminal:	Line		
Test Mode:	AC Charging with TX B Mode		
Remark:	Only worst case is reported		

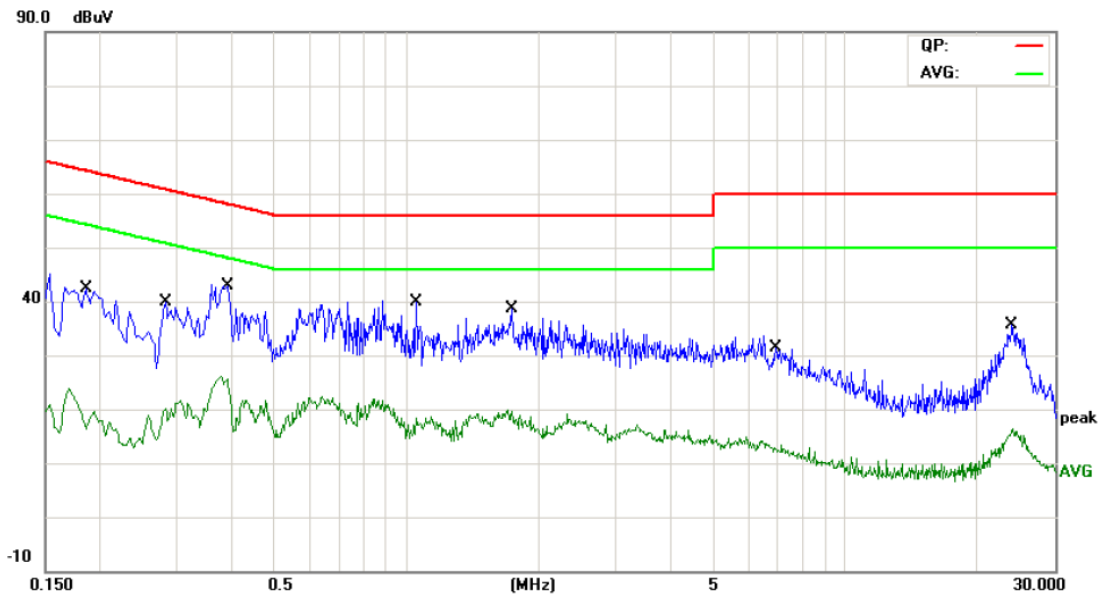

No.	Mk.	Freq. MHz	Reading Level dBuV	Correct Factor dB	Measure- ment dBuV	Limit dBuV	Over dB	Detector	Comment
1		0.1860	24.37	9.99	34.36	64.21	-29.85	QP	
2		0.1860	5.00	9.99	14.99	54.21	-39.22	AVG	
3		0.2819	19.28	10.02	29.30	60.76	-31.46	QP	
4		0.2819	5.40	10.02	15.42	50.76	-35.34	AVG	
5	*	0.3899	26.39	10.02	36.41	58.06	-21.65	QP	
6		0.3899	13.28	10.02	23.30	48.06	-24.76	AVG	
7		1.0500	15.74	10.06	25.80	56.00	-30.20	QP	
8		1.0500	5.11	10.06	15.17	46.00	-30.83	AVG	
9		1.7380	17.16	10.06	27.22	56.00	-28.78	QP	
10		1.7380	7.73	10.06	17.79	46.00	-28.21	AVG	
11		6.9220	10.41	10.06	20.47	60.00	-39.53	QP	
12		6.9220	1.07	10.06	11.13	50.00	-38.87	AVG	

*:Maximum data x:Over limit !:over margin

Emission Level= Read Level+ Correct Factor

EUT:	Gurubook 5/MID	Model Name :	GURUBOOK5
Temperature:	25 °C	Relative Humidity:	55%
Test Voltage:	AC 120V/60 Hz		
Terminal:	Neutral		
Test Mode:	AC Charging with TX B Mode		
Remark:	Only worst case is reported		

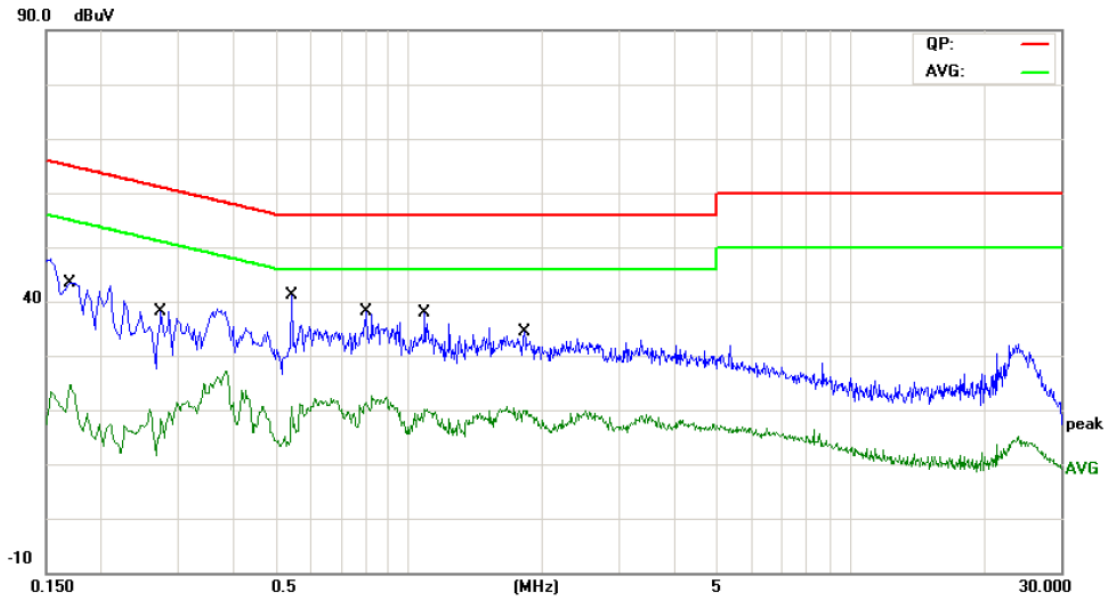

No.	Mk.	Freq.	Reading Level	Correct Factor	Measurement	Limit	Over	Detector	Comment
		MHz	dBuV	dB	dBuV	dBuV	dB		
1	*	0.1700	28.00	9.96	37.96	64.96	-27.00	QP	
2		0.1700	12.68	9.96	22.64	54.96	-32.32	AVG	
3		0.2740	17.38	10.02	27.40	60.99	-33.59	QP	
4		0.2740	1.84	10.02	11.86	50.99	-39.13	AVG	
5		0.5420	16.17	10.04	26.21	56.00	-29.79	QP	
6		0.5420	5.30	10.04	15.34	46.00	-30.66	AVG	
7		0.7980	18.05	10.10	28.15	56.00	-27.85	QP	
8		0.7980	8.63	10.10	18.73	46.00	-27.27	AVG	
9		1.0859	17.79	10.06	27.85	56.00	-28.15	QP	
10		1.0859	8.15	10.06	18.21	46.00	-27.79	AVG	
11		1.8220	16.05	10.06	26.11	56.00	-29.89	QP	
12		1.8220	7.68	10.06	17.74	46.00	-28.26	AVG	

*:Maximum data x:Over limit !:over margin

Emission Level= Read Level+ Correct Factor

4. Radiated Emission Test

4.1 Test Standard and Limit

4.1.1 Test Standard

FCC Part 15.209

4.1.2 Test Limit

Radiated Emission Limits (9kHz~1000MHz)

Frequency (MHz)	Field Strength (microvolt/meter)	Measurement Distance (meters)
0.009~0.490	2400/F(KHz)	300
0.490~1.705	24000/F(KHz)	30
1.705~30.0	30	30
30~88	100	3
88~216	150	3
216~960	200	3
Above 960	500	3

Radiated Emission Limit (Above 1000MHz)

Frequency (MHz)	Class A (dBuV/m)(at 3 M)		Class B (dBuV/m)(at 3 M)	
	Peak	Average	Peak	Average
Above 1000	80	60	74	54

Note:

- (1) The tighter limit applies at the band edges.
- (2) Emission Level(dBuV/m)=20log Emission Level(uV/m)

4.2 Test Setup

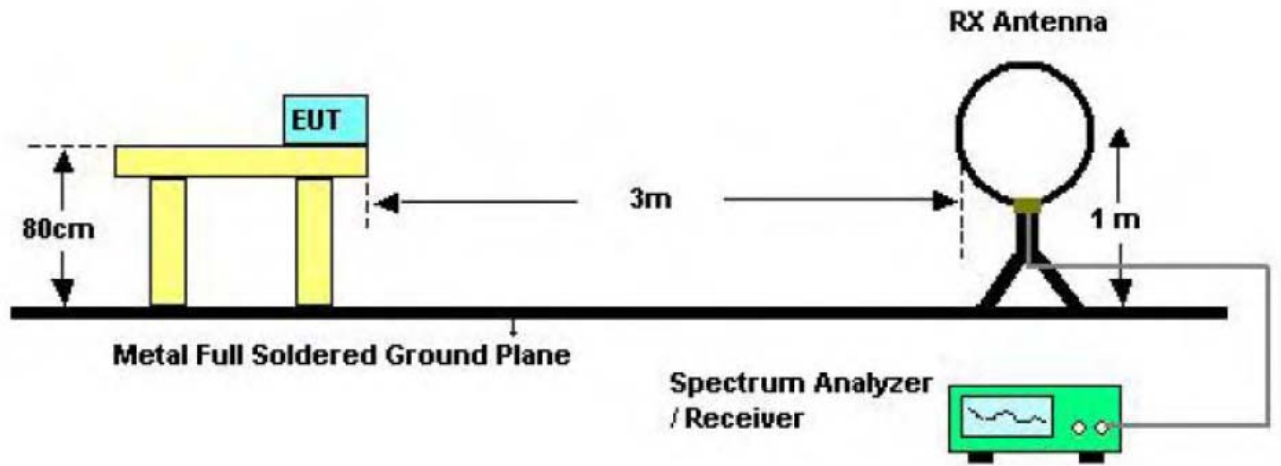

Below 30MHz Test Setup

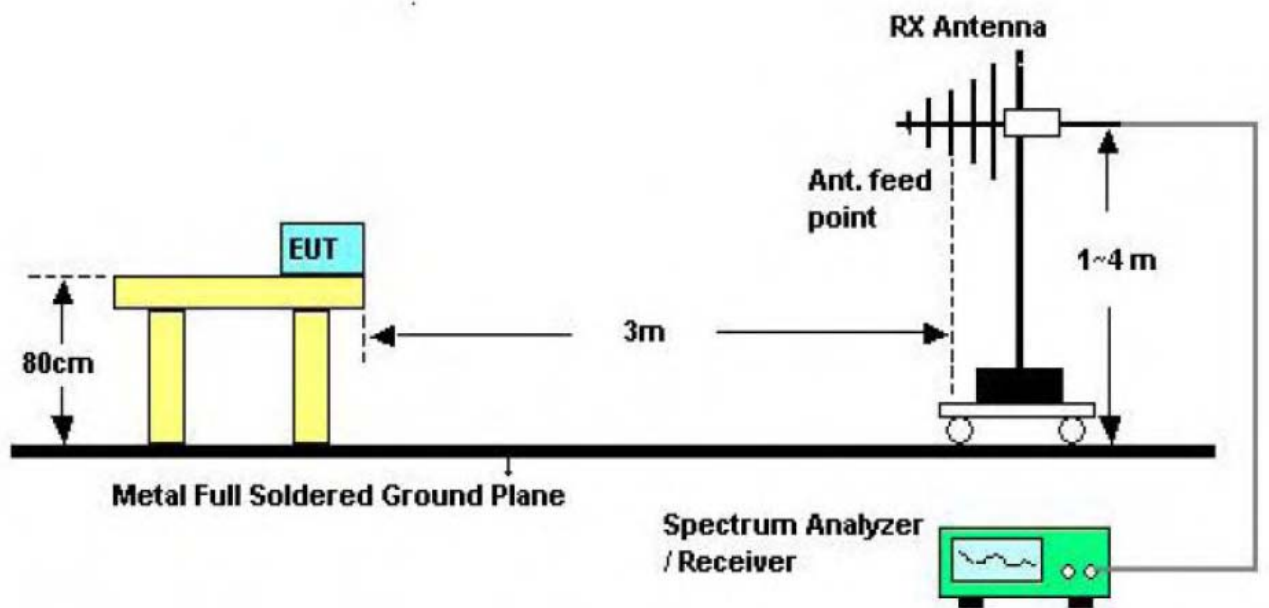

Below 1000MHz Test Setup

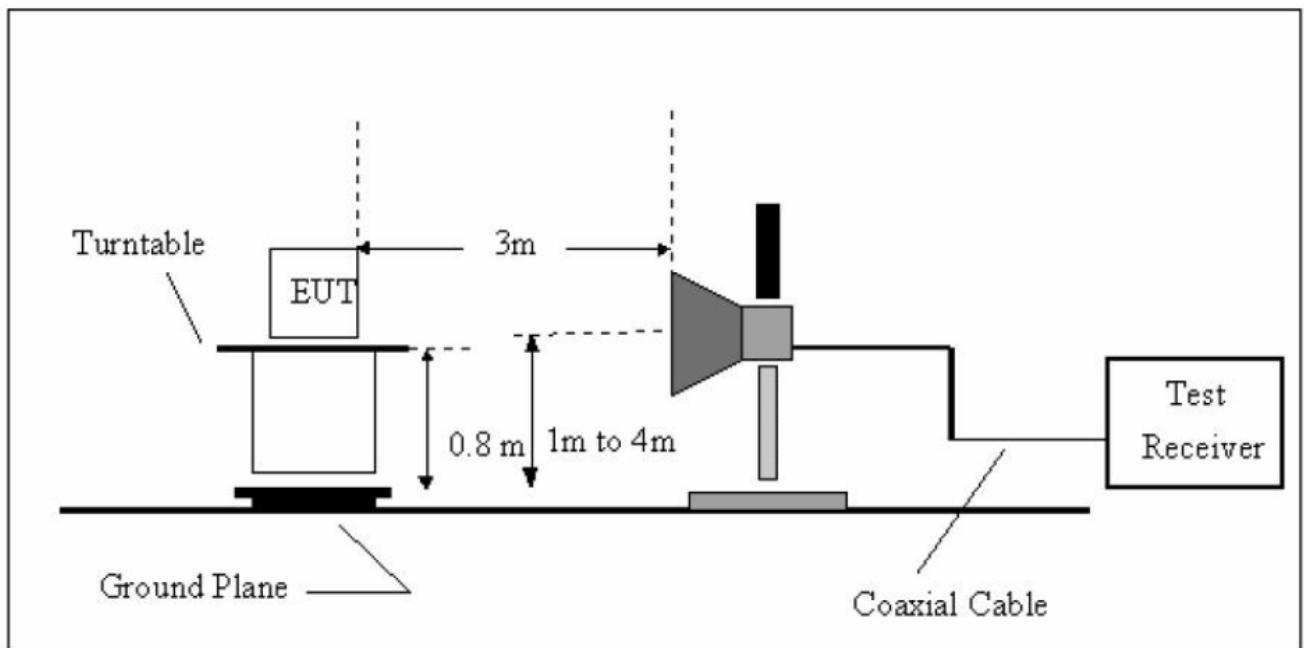

Above 1GHz Test Setup

4.3 Test Procedure

- (1) The measuring distance of 3m shall be used for measurements at frequency up to 1GHz and above 1 GHz. The EUT was placed on a rotating 0.8m high above the ground, the table was rotated 360 degrees to determine the position of the highest radiation.
- (2) The Test antenna shall vary between 1m and 4m, Both Horizontal and Vertical antenna are set to make measurement.
- (3) The initial step in collecting conducted emission data is a spectrum analyzer peak detector mode pre-scanning the measurement frequency range. Significant peaks are then marked and then Quasi Peak detector mode re-measured.
- (4) If the Peak Mode measured value compliance with and lower than Quasi Peak Mode Limit Bellow 1 GHz, the EUT shall be deemed to meet QP Limits and then no additional QP Mode measurement performed. But the Peak Value and average value both need to comply with applicable limit above 1 GHz.
- (5) Testing frequency range below 1GHz the measuring instrument use VBW=120 kHz with Quasi-peak detection.
- (6) Testing frequency range above 1GHz the measuring instrument use RBW=1 MHz and VBW=3 MHz with Peak Detector for Peak Values, and use RBW=1 MHz and VBW=10 Hz with Peak Detector for Average Values.
- (7) For the actual test configuration, please see the test setup photo.

4.4 EUT Operating Condition

The Equipment Under Test was set to Continual Transmitting in maximum power.

4.5 Test Equipment

Equipment	Manufacturer	Model No.	Serial No.	Last Cal.	Cal. Due Date
Spectrum Analyzer	Agilent	E4407B	MY45106456	Mar. 20, 2014	Mar. 19, 2015
Spectrum Analyzer	Rohde & Schwarz	FSP30	DE25181	Aug. 08, 2014	Aug. 07, 2015
EMI Test Receiver	Rohde & Schwarz	ESCI	101165	Aug. 08, 2014	Aug. 07, 2015
Bilog Antenna	ETS-LINDGREN	3142E	00117537	Mar. 07, 2014	Mar.06, 2015
Bilog Antenna	ETS-LINDGREN	3142E	00117542	Mar. 07, 2014	Mar.06, 2015
Horn Antenna	ETS-LINDGREN	3117	00143207	Mar. 07, 2014	Mar.06, 2015
Horn Antenna	ETS-LINDGREN	3117	00143209	Mar. 07, 2014	Mar.06, 2015
Pre-amplifier	HP	11909A	185903	Mar. 07, 2014	Mar.06, 2015
Pre-amplifier	HP	8447B	3008A00849	Mar. 07, 2014	Mar.06, 2015
Cable	HUBER+SUHNER	100	SUCOFLEX	Mar. 07, 2014	Mar.06, 2015
Signal Generator	Rohde & Schwarz	SML03	IKW682-054	Feb. 11, 2014	Feb.10, 2015
Positioning Controller	ETS-LINDGREN	2090	N/A	N/A	N/A

4.6 Test Data

Remark: During testing above 1GHz the measuring instrument use RBW=1 MHz and VBW=3 MHz with Peak Detector for Peak Values, and use RBW=1 MHz and VBW=10 Hz with Peak Detector for Average Values.

Test data please refer the following pages.

EUT:	Gurubook 5/MID	Model Name :	GURUBOOK5
Temperature:	25 °C	Relative Humidity:	55%
Test Voltage:	AC 120V/60 Hz		
Ant. Pol.	Horizontal		
Test Mode:	TX B Mode 2412MHz		
Remark:	Only worst case is reported		

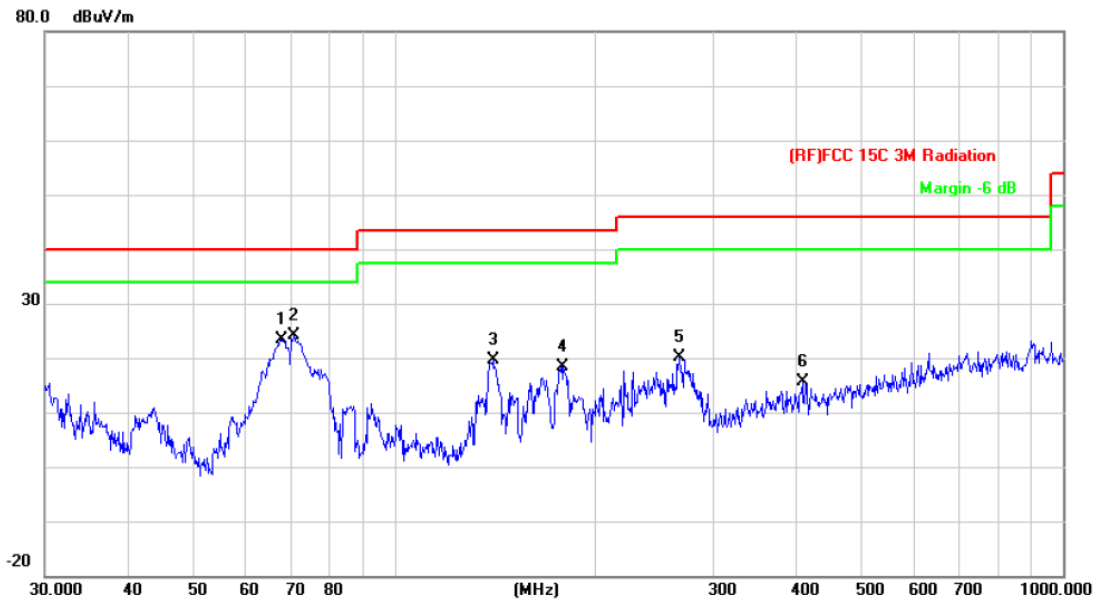

No.	Mk.	Freq.	Reading Level	Correct Factor	Measurement	Limit	Over	Detector
		MHz	dBuV	dB/m	dBuV/m	dBuV/m	dB	
1		67.9129	47.14	-23.80	23.34	40.00	-16.66	peak
2	*	70.8315	47.80	-23.59	24.21	40.00	-15.79	peak
3		140.3421	41.53	-21.95	19.58	43.50	-23.92	peak
4		178.7584	39.05	-20.64	18.41	43.50	-25.09	peak
5		266.6089	37.84	-17.76	20.08	46.00	-25.92	peak
6		407.5145	28.37	-12.84	15.53	46.00	-30.47	peak

*:Maximum data x:Over limit !:over margin

Emission Level= Read Level+ Correct Factor

EUT:	Gurubook 5/MID	Model Name :	GURUBOOK5
Temperature:	25 °C	Relative Humidity:	55%
Test Voltage:	AC 120V/60 Hz		
Ant. Pol.	Vertical		
Test Mode:	TX B Mode 2412MHz		
Remark:	Only worst case is reported		

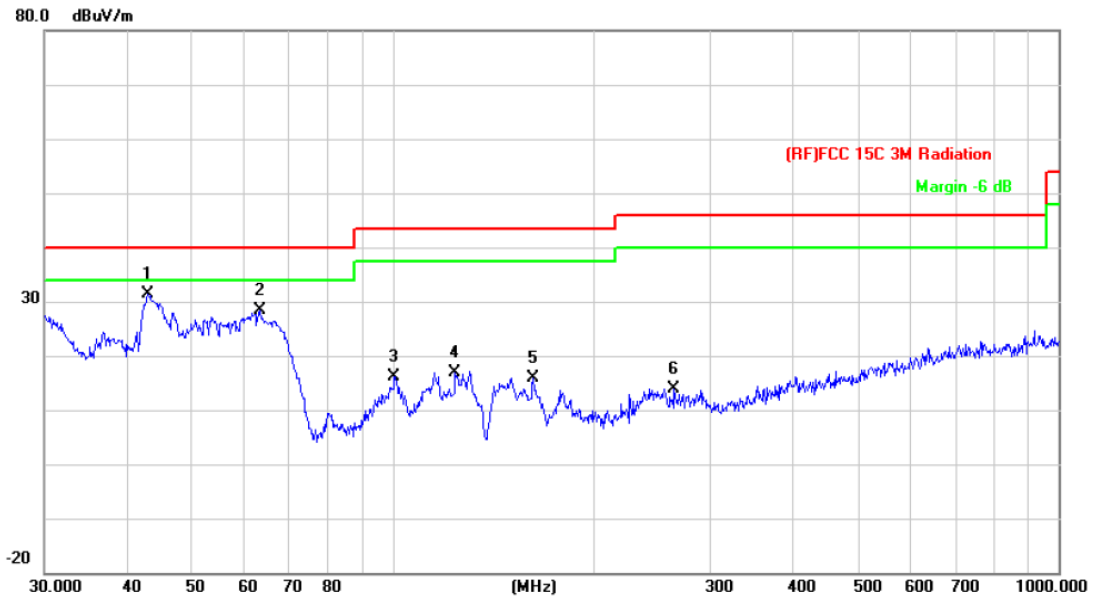

No.	Mk.	Freq.	Reading Level	Correct Factor	Measurement	Limit	Over	
		MHz	dBuV	dB/m	dBuV/m	dBuV/m	dB	Detector
1	*	42.8998	52.88	-21.39	31.49	40.00	-8.51	peak
2		63.3132	52.68	-24.22	28.46	40.00	-11.54	peak
3		100.5806	38.01	-21.82	16.19	43.50	-27.31	peak
4		124.1330	39.36	-22.37	16.99	43.50	-26.51	peak
5		162.6106	36.55	-20.68	15.87	43.50	-27.63	peak
6		264.7457	31.72	-17.80	13.92	46.00	-32.08	peak

*:Maximum data x:Over limit !:over margin

Emission Level= Read Level+ Correct Factor

EUT:	Gurubook 5/MID	Model Name :	GURUBOOK5
Temperature:	25 °C	Relative Humidity:	55%
Test Voltage:	AC 120V/60 Hz		
Ant. Pol.	Horizontal		
Test Mode:	TX B Mode 2412MHz		
Remark:	No report for the emission which more than 10 dB below the prescribed limit.		

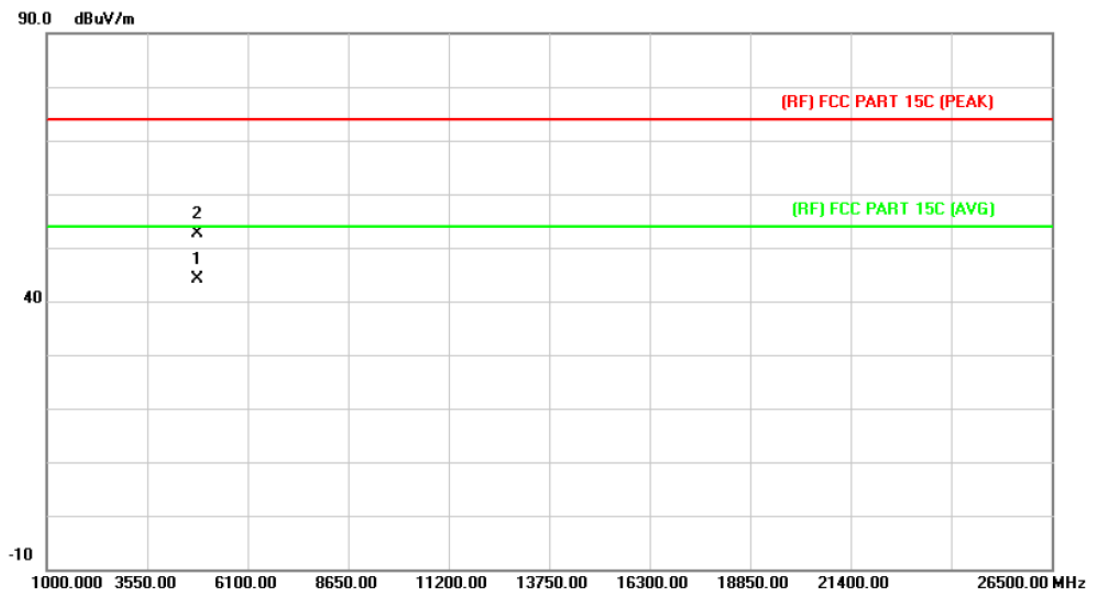

No.	Mk.	Freq.	Reading Level	Correct Factor	Measurement	Limit	Over	Detector
		MHz	dBuV	dB/m	dBuV/m	dBuV/m	dB	
1	*	4824.012	30.55	13.56	44.11	54.00	-9.89	AVG
2		4824.364	39.17	13.56	52.73	74.00	-21.27	peak

Emission Level= Read Level+ Correct Factor

EUT:	Gurubook 5/MID	Model Name :	GURUBOOK5
Temperature:	25 °C	Relative Humidity:	55%
Test Voltage:	AC 120V/60 Hz		
Ant. Pol.	Vertical		
Test Mode:	TX B Mode 2412MHz		
Remark:	No report for the emission which more than 10 dB below the prescribed limit.		

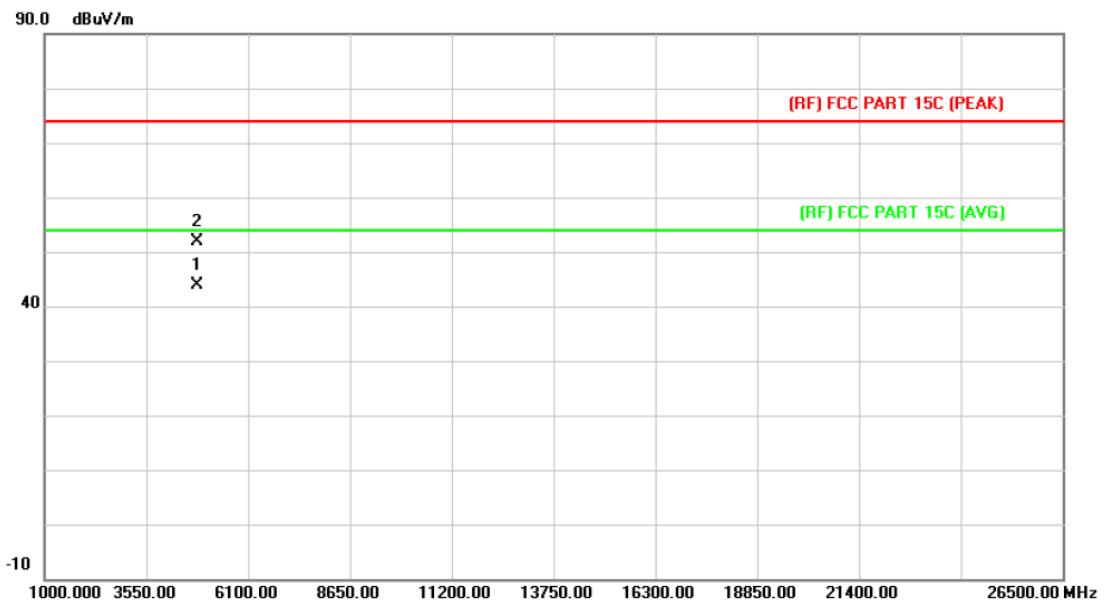

No.	Mk.	Freq.	Reading Level	Correct Factor	Measurement	Limit	Over	Detector
		MHz	dBuV	dB/m	dBuV/m	dBuV/m	dB	
1	*	4824.009	30.33	13.56	43.89	54.00	-10.11	AVG
2		4824.159	38.38	13.56	51.94	74.00	-22.06	peak

Emission Level= Read Level+ Correct Factor

EUT:	Gurubook 5/MID	Model Name :	GURUBOOK5
Temperature:	25 °C	Relative Humidity:	55%
Test Voltage:	AC 120V/60 Hz		
Ant. Pol.	Horizontal		
Test Mode:	TX B Mode 2437MHz		
Remark:	No report for the emission which more than 10 dB below the prescribed limit.		

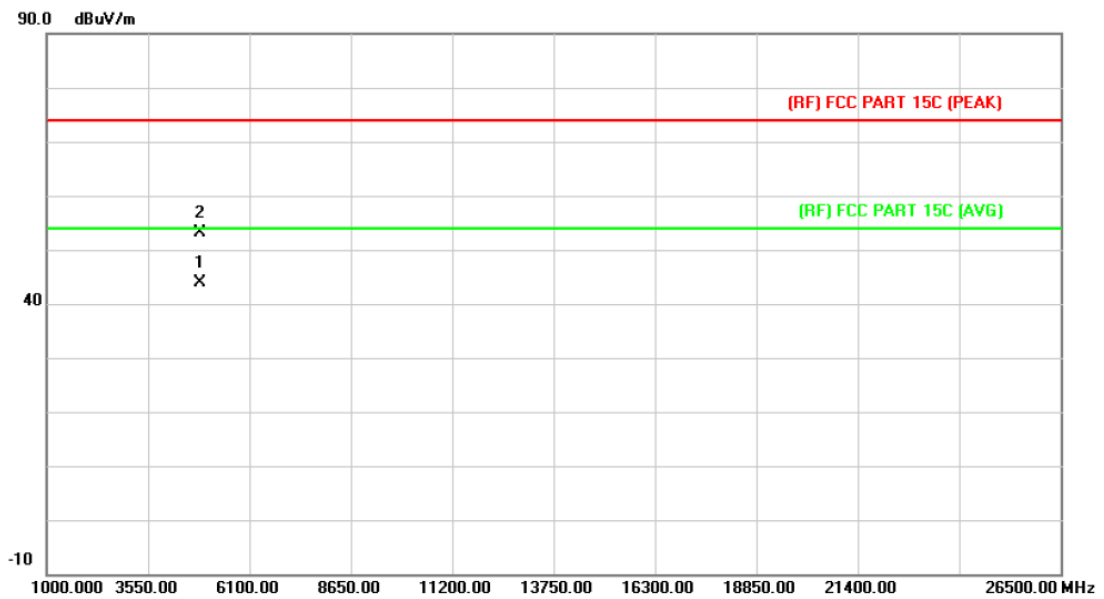

No.	Mk.	Freq. MHz	Reading Level dBuV	Correct Factor dB/m	Measure- ment dBuV/m	Limit dBuV/m	Over dB	Detector
1	*	4873.456	30.01	13.86	43.87	54.00	-10.13	AVG
2		4873.987	39.16	13.86	53.02	74.00	-20.98	peak

Emission Level= Read Level+ Correct Factor

EUT:	Gurubook 5/MID	Model Name :	GURUBOOK5
Temperature:	25 °C	Relative Humidity:	55%
Test Voltage:	AC 120V/60 Hz		
Ant. Pol.	Vertical		
Test Mode:	TX B Mode 2437MHz		
Remark:	No report for the emission which more than 10 dB below the prescribed limit.		

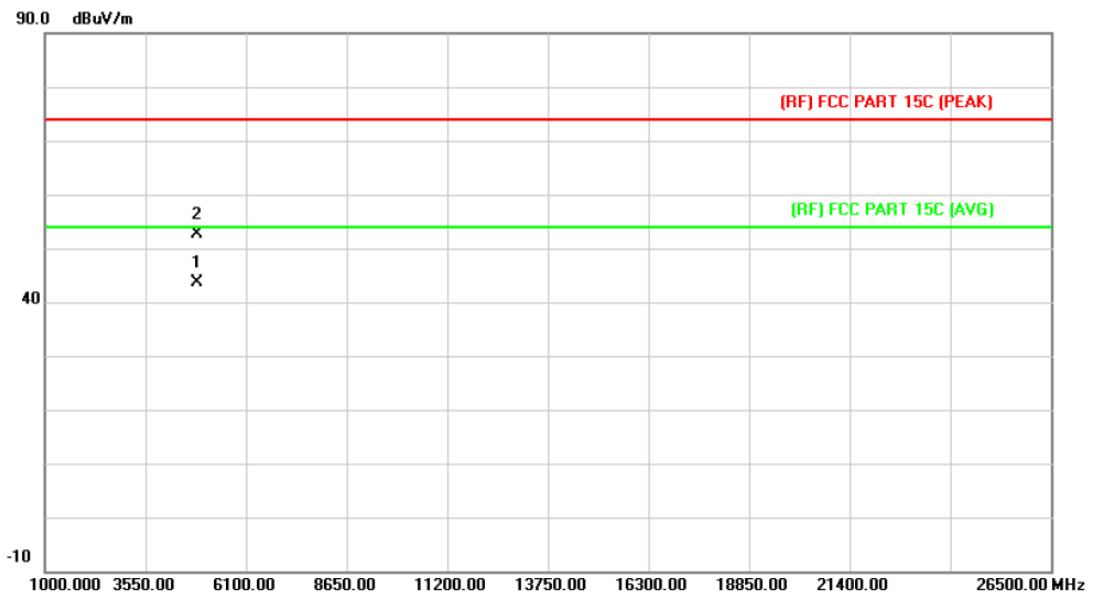

No.	Mk.	Freq.	Reading Level	Correct Factor	Measurement	Limit	Over	Detector
		MHz	dBuV	dB/m	dBuV/m	dBuV/m	dB	
1	*	4874.001	29.89	13.86	43.75	54.00	-10.25	AVG
2		4874.310	38.83	13.86	52.69	74.00	-21.31	peak

Emission Level= Read Level+ Correct Factor

EUT:	Gurubook 5/MID	Model Name :	GURUBOOK5
Temperature:	25 °C	Relative Humidity:	55%
Test Voltage:	AC 120V/60 Hz		
Ant. Pol.	Horizontal		
Test Mode:	TX B Mode 2462MHz		
Remark:	No report for the emission which more than 10 dB below the prescribed limit.		

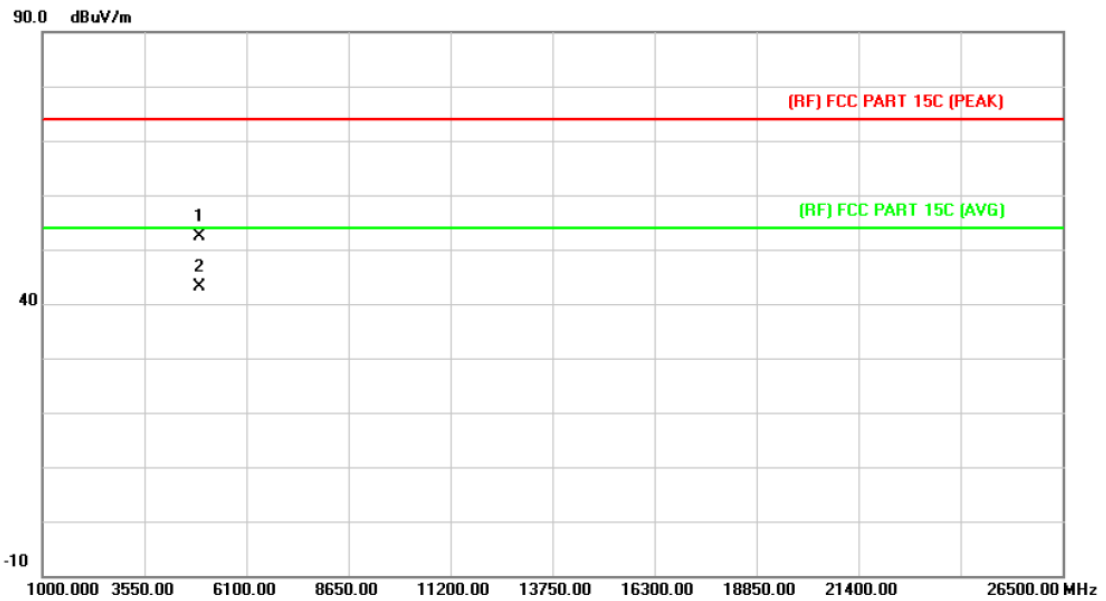

No.	Mk.	Freq.	Reading Level	Correct Factor	Measurement	Limit	Over	Detector
		MHz	dBuV	dB/m	dBuV/m	dBuV/m	dB	
1		4923.148	38.18	14.15	52.33	74.00	-21.67	peak
2	*	4923.674	28.96	14.15	43.11	54.00	-10.89	AVG

Emission Level= Read Level+ Correct Factor

EUT:	Gurubook 5/MID	Model Name :	GURUBOOK5
Temperature:	25 °C	Relative Humidity:	55%
Test Voltage:	AC 120V/60 Hz		
Ant. Pol.	Vertical		
Test Mode:	TX B Mode 2462MHz		
Remark:	No report for the emission which more than 10 dB below the prescribed limit.		

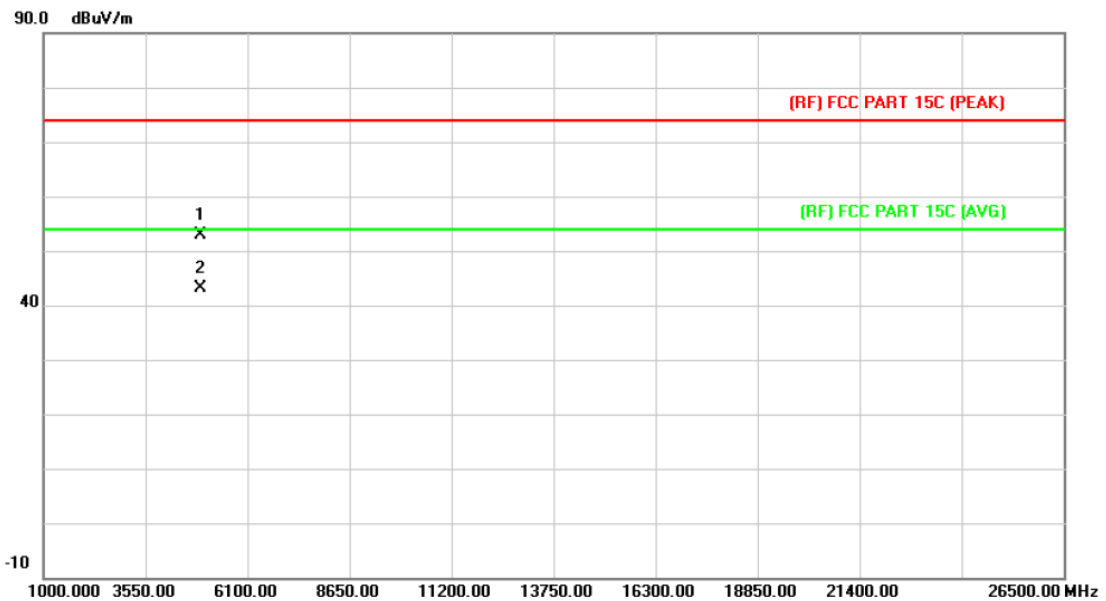

No.	Mk.	Freq.	Reading Level	Correct Factor	Measurement	Limit	Over	Detector
		MHz	dBuV	dB/m	dBuV/m	dBuV/m	dB	
1		4923.147	38.66	14.15	52.81	74.00	-21.19	peak
2	*	4923.611	29.00	14.15	43.15	54.00	-10.85	AVG

Emission Level= Read Level+ Correct Factor

EUT:	Gurubook 5/MID	Model Name :	GURUBOOK5
Temperature:	25 °C	Relative Humidity:	55%
Test Voltage:	AC 120V/60 Hz		
Ant. Pol.	Horizontal		
Test Mode:	TX G Mode 2412MHz		
Remark:	No report for the emission which more than 10 dB below the prescribed limit.		

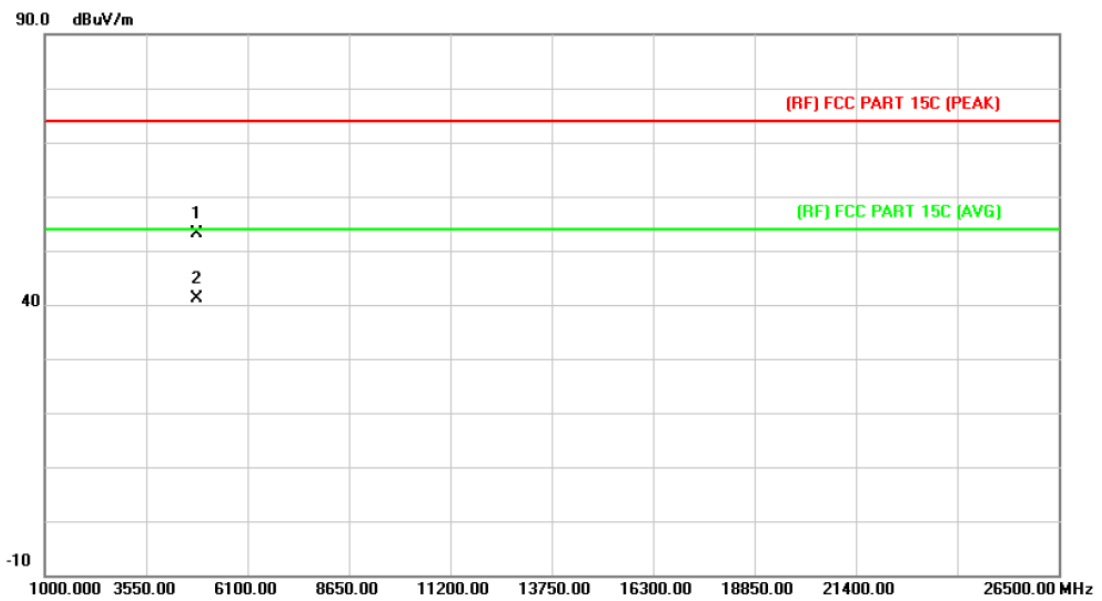

No.	Mk.	Freq.	Reading Level	Correct Factor	Measurement	Limit	Over	Detector
		MHz	dBuV	dB/m	dBuV/m	dBuV/m	dB	
1		4823.271	39.52	13.56	53.08	74.00	-20.92	peak
2	*	4823.612	27.46	13.56	41.02	54.00	-12.98	AVG

Emission Level= Read Level+ Correct Factor

EUT:	Gurubook 5/MID	Model Name :	GURUBOOK5
Temperature:	25 °C	Relative Humidity:	55%
Test Voltage:	AC 120V/60 Hz		
Ant. Pol.	Vertical		
Test Mode:	TX G Mode 2412MHz		
Remark:	No report for the emission which more than 10 dB below the prescribed limit.		

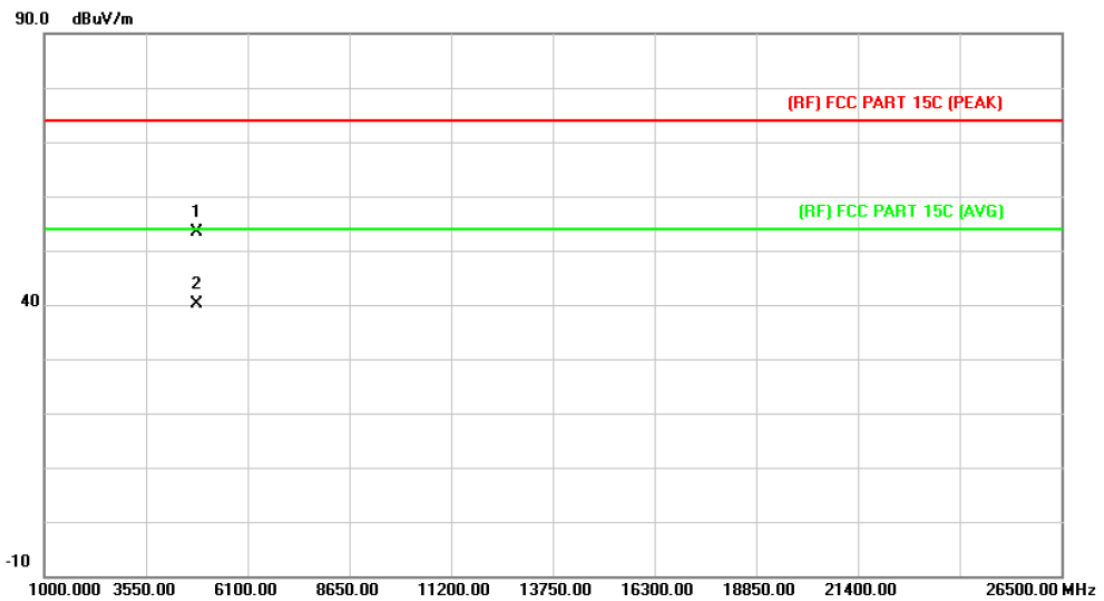

No.	Mk.	Freq. MHz	Reading Level dBuV	Correct Factor dB/m	Measure- ment dBuV/m	Limit dBuV/m	Over dB	Detector
1		4823.484	39.86	13.56	53.42	74.00	-20.58	peak
2	*	4823.697	26.69	13.56	40.25	54.00	-13.75	AVG

Emission Level= Read Level+ Correct Factor

EUT:	Gurubook 5/MID	Model Name :	GURUBOOK5
Temperature:	25 °C	Relative Humidity:	55%
Test Voltage:	AC 120V/60 Hz		
Ant. Pol.	Horizontal		
Test Mode:	TX G Mode 2437MHz		
Remark:	No report for the emission which more than 10 dB below the prescribed limit.		

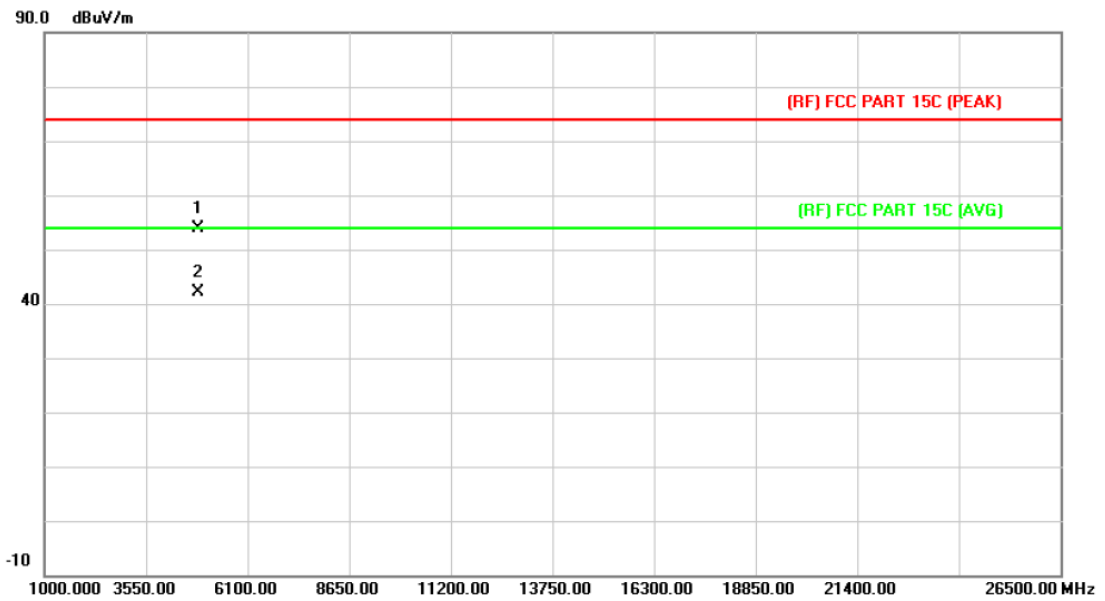

No.	Mk.	Freq.	Reading Level	Correct Factor	Measurement	Limit	Over	Detector
		MHz	dBuV	dB/m	dBuV/m	dBuV/m	dB	
1		4873.193	40.01	13.86	53.87	74.00	-20.13	peak
2	*	4873.671	28.23	13.86	42.09	54.00	-11.91	AVG

Emission Level= Read Level+ Correct Factor

EUT:	Gurubook 5/MID	Model Name :	GURUBOOK5
Temperature:	25 °C	Relative Humidity:	55%
Test Voltage:	AC 120V/60 Hz		
Ant. Pol.	Vertical		
Test Mode:	TX G Mode 2437MHz		
Remark:	No report for the emission which more than 10 dB below the prescribed limit.		

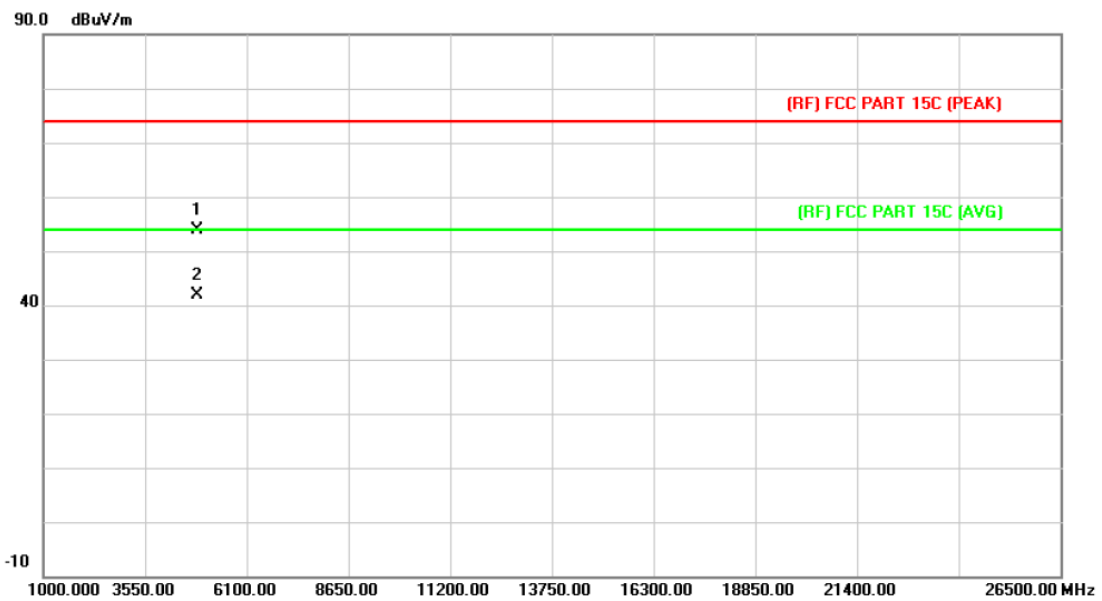

No.	Mk.	Freq.	Reading Level	Correct Factor	Measurement	Limit	Over	Detector
		MHz	dBuV	dB/m	dBuV/m	dBuV/m	dB	
1		4873.674	39.90	13.86	53.76	74.00	-20.24	peak
2	*	4873.687	27.96	13.86	41.82	54.00	-12.18	AVG

Emission Level= Read Level+ Correct Factor

EUT:	Gurubook 5/MID	Model Name :	GURUBOOK5
Temperature:	25 °C	Relative Humidity:	55%
Test Voltage:	AC 120V/60 Hz		
Ant. Pol.	Horizontal		
Test Mode:	TX G Mode 2462MHz		
Remark:	No report for the emission which more than 10 dB below the prescribed limit.		

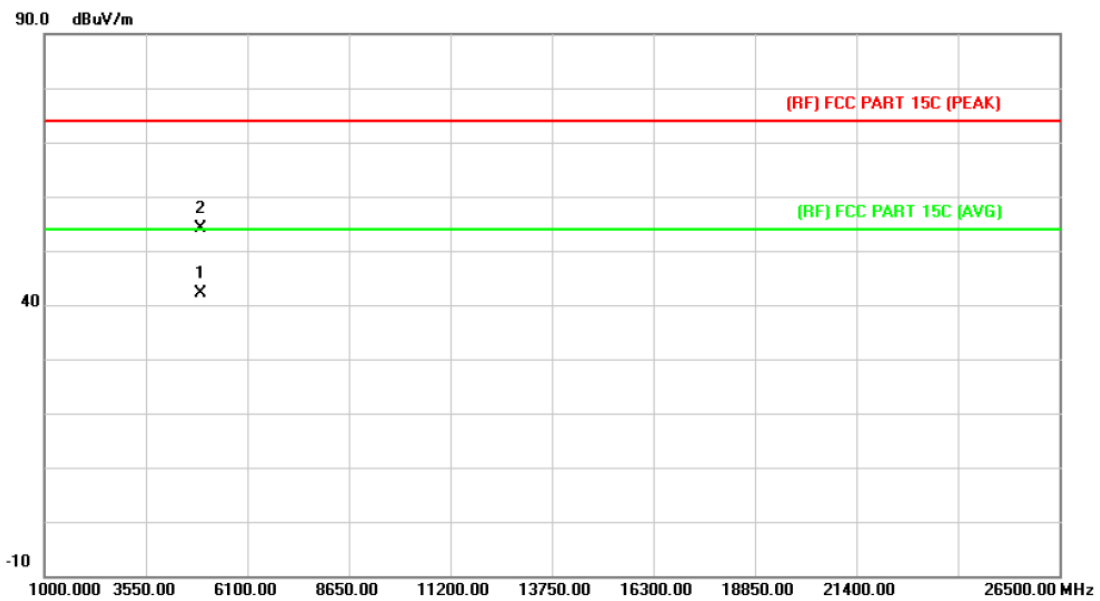

No.	Mk.	Freq.	Reading Level	Correct Factor	Measurement	Limit	Over	Detector
		MHz	dBuV	dB/m	dBuV/m	dBuV/m	dB	
1	*	4923.126	27.97	14.15	42.12	54.00	-11.88	AVG
2		4923.148	39.86	14.15	54.01	74.00	-19.99	peak

Emission Level= Read Level+ Correct Factor

EUT:	Gurubook 5/MID	Model Name :	GURUBOOK5
Temperature:	25 °C	Relative Humidity:	55%
Test Voltage:	AC 120V/60 Hz		
Ant. Pol.	Vertical		
Test Mode:	TX G Mode 2462MHz		
Remark:	No report for the emission which more than 10 dB below the prescribed limit.		

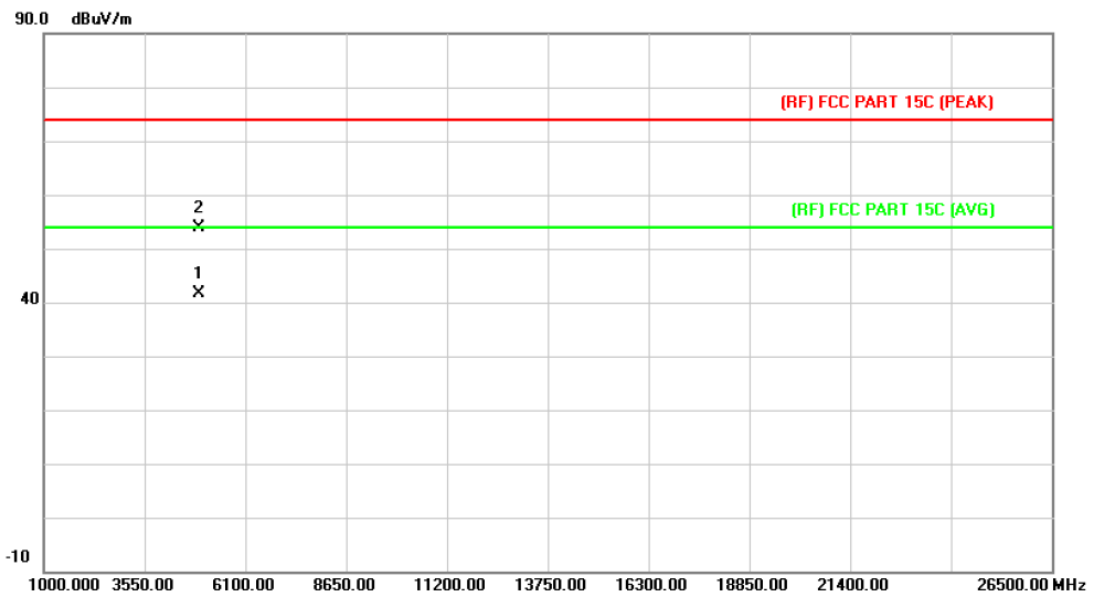

No.	Mk.	Freq.	Reading Level	Correct Factor	Measurement	Limit	Over	Detector
		MHz	dBuV	dB/m	dBuV/m	dBuV/m	dB	
1	*	4923.428	27.54	14.15	41.69	54.00	-12.31	AVG
2		4923.670	39.83	14.15	53.98	74.00	-20.02	peak

Emission Level= Read Level+ Correct Factor

EUT:	Gurubook 5/MID	Model Name :	GURUBOOK5
Temperature:	25 °C	Relative Humidity:	55%
Test Voltage:	AC 120V/60 Hz		
Ant. Pol.	Horizontal		
Test Mode:	TX N(HT20) Mode 2412MHz		
Remark:	No report for the emission which more than 10 dB below the prescribed limit.		

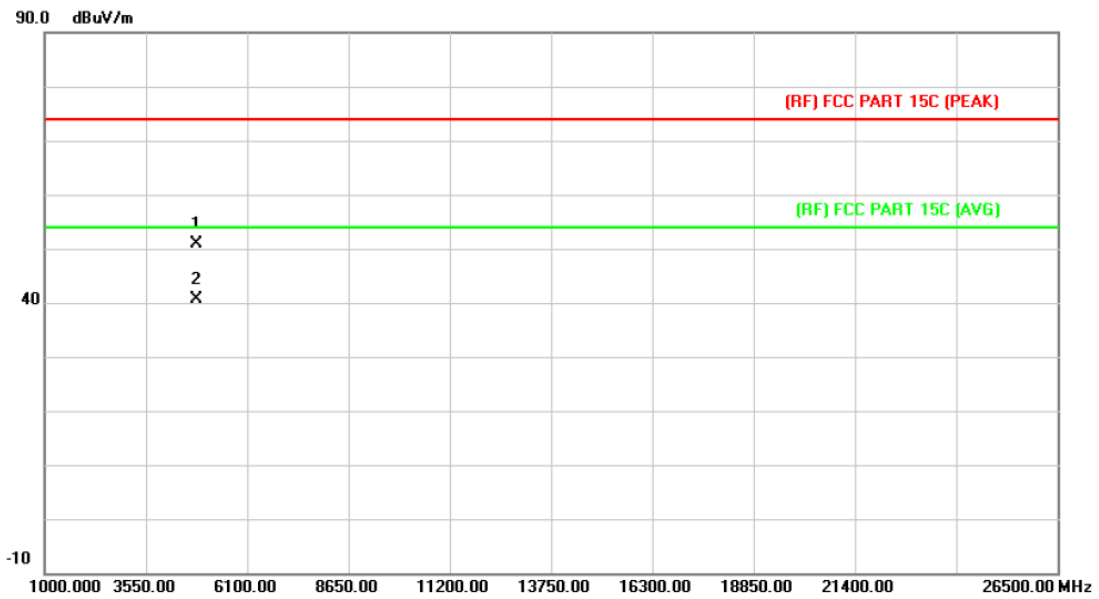

No.	Mk.	Freq.	Reading Level	Correct Factor	Measurement	Limit	Over	Detector
		MHz	dBuV	dB/m	dBuV/m	dBuV/m	dB	
1		4823.173	37.25	13.56	50.81	74.00	-23.19	peak
2	*	4823.354	27.00	13.56	40.56	54.00	-13.44	AVG

Emission Level= Read Level+ Correct Factor

EUT:	Gurubook 5/MID	Model Name :	GURUBOOK5
Temperature:	25 °C	Relative Humidity:	55%
Test Voltage:	AC 120V/60 Hz		
Ant. Pol.	Vertical		
Test Mode:	TX N(HT20) Mode 2412MHz		
Remark:	No report for the emission which more than 10 dB below the prescribed limit.		

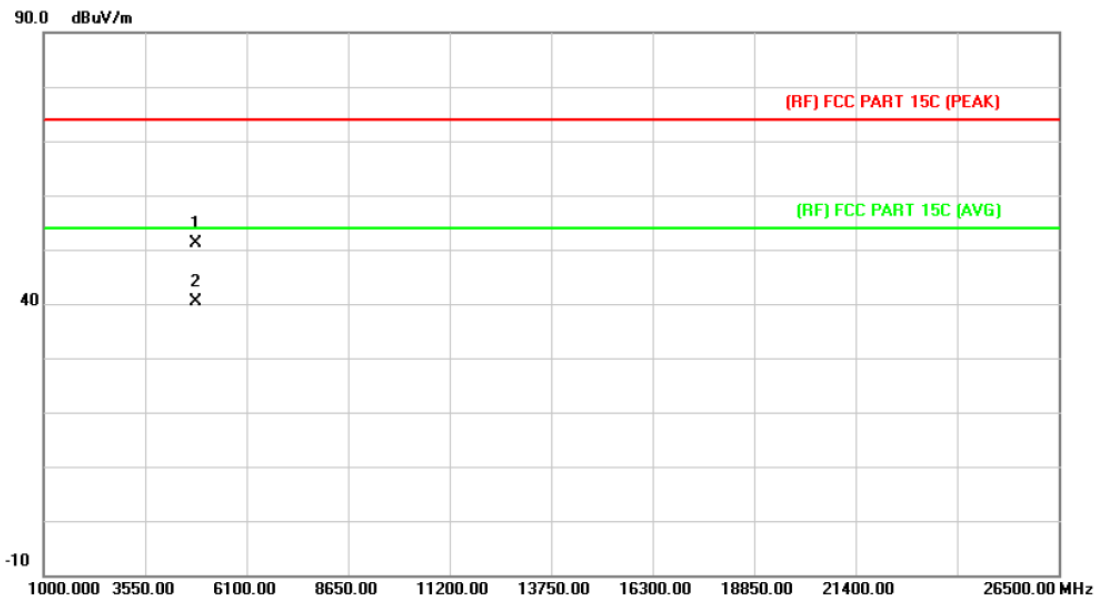

No.	Mk.	Freq. MHz	Reading Level dBuV	Correct Factor dB/m	Measure- ment dBuV/m	Limit dBuV/m	Over dB	Detector
1		4823.764	37.55	13.56	51.11	74.00	-22.89	peak
2	*	4823.831	26.76	13.56	40.32	54.00	-13.68	AVG

Emission Level= Read Level+ Correct Factor

EUT:	Gurubook 5/MID	Model Name :	GURUBOOK5
Temperature:	25 °C	Relative Humidity:	55%
Test Voltage:	AC 120V/60 Hz		
Ant. Pol.	Horizontal		
Test Mode:	TX N(HT20) Mode 2437MHz		
Remark:	No report for the emission which more than 10 dB below the prescribed limit.		

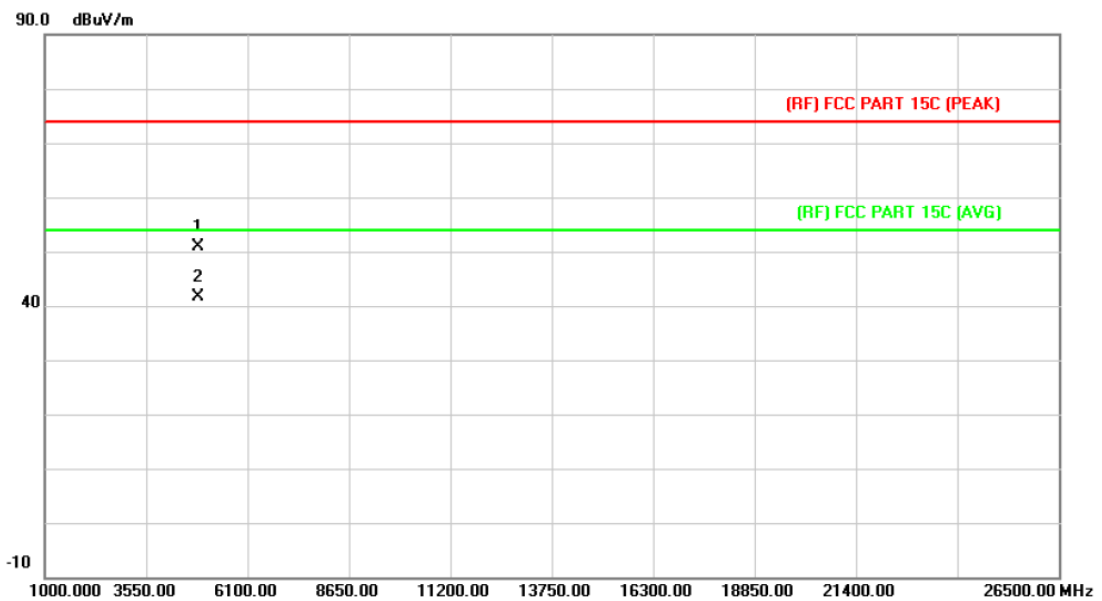

No.	Mk.	Freq.	Reading Level	Correct Factor	Measurement	Limit	Over	Detector
		MHz	dBuV	dB/m	dBuV/m	dBuV/m	dB	
1		4873.128	37.10	13.86	50.96	74.00	-23.04	peak
2	*	4873.684	27.86	13.86	41.72	54.00	-12.28	AVG

Emission Level= Read Level+ Correct Factor

EUT:	Gurubook 5/MID	Model Name :	GURUBOOK5
Temperature:	25 °C	Relative Humidity:	55%
Test Voltage:	AC 120V/60 Hz		
Ant. Pol.	Vertical		
Test Mode:	TX N(HT20) Mode 2437MHz		
Remark:	No report for the emission which more than 10 dB below the prescribed limit.		

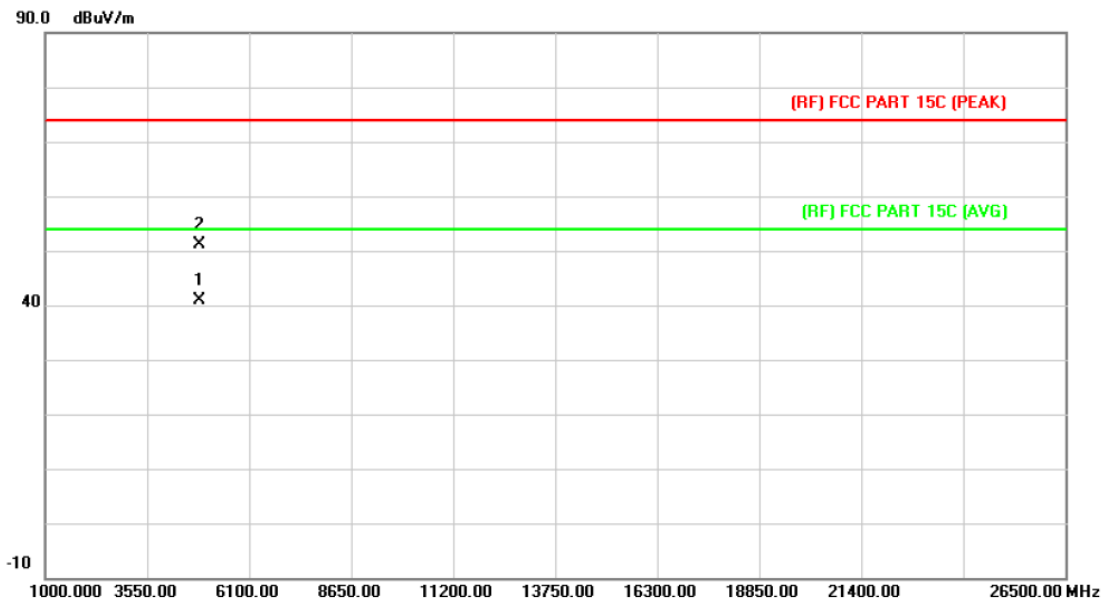

No.	Mk.	Freq.	Reading Level	Correct Factor	Measurement	Limit	Over	Detector
		MHz	dBuV	dB/m	dBuV/m	dBuV/m	dB	
1	*	4873.345	26.96	13.86	40.82	54.00	-13.18	AVG
2		4873.654	37.17	13.86	51.03	74.00	-22.97	peak

Emission Level= Read Level+ Correct Factor

EUT:	Gurubook 5/MID	Model Name :	GURUBOOK5
Temperature:	25 °C	Relative Humidity:	55%
Test Voltage:	AC 120V/60 Hz		
Ant. Pol.	Horizontal		
Test Mode:	TX N(HT20) Mode 2462MHz		
Remark:	No report for the emission which more than 10 dB below the prescribed limit.		

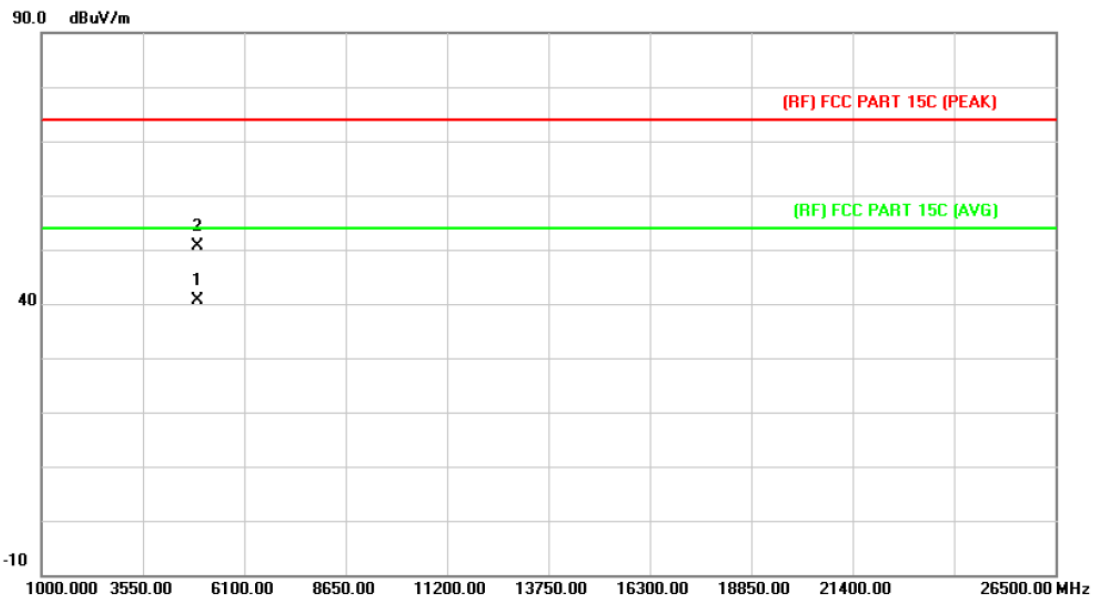

No.	Mk.	Freq.	Reading Level	Correct Factor	Measurement	Limit	Over	Detector
		MHz	dBuV	dB/m	dBuV/m	dBuV/m	dB	
1	*	4923.646	26.46	14.15	40.61	54.00	-13.39	AVG
2		4923.751	36.40	14.15	50.55	74.00	-23.45	peak

Emission Level= Read Level+ Correct Factor

EUT:	Gurubook 5/MID	Model Name :	GURUBOOK5
Temperature:	25 °C	Relative Humidity:	55%
Test Voltage:	AC 120V/60 Hz		
Ant. Pol.	Vertical		
Test Mode:	TX N(HT20) Mode 2462MHz		
Remark:	No report for the emission which more than 10 dB below the prescribed limit.		

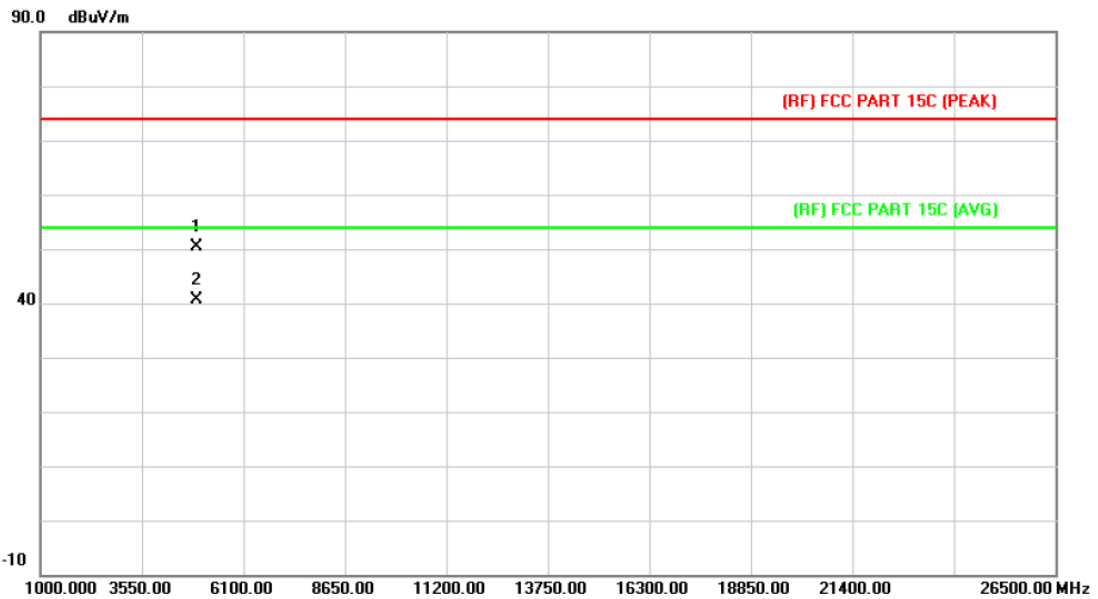

No.	Mk.	Freq. MHz	Reading Level dBuV	Correct Factor dB/m	Measure- ment dBuV/m	Limit dBuV/m	Over dB	Detector
1		4923.501	36.21	14.15	50.36	74.00	-23.64	peak
2	*	4923.603	26.59	14.15	40.74	54.00	-13.26	AVG

Emission Level= Read Level+ Correct Factor

EUT:	Gurubook 5/MID	Model Name :	GURUBOOK5
Temperature:	25 °C	Relative Humidity:	55%
Test Voltage:	AC 120V/60 Hz		
Ant. Pol.	Horizontal		
Test Mode:	TX N(HT40) Mode 2422MHz		
Remark:	No report for the emission which more than 10 dB below the prescribed limit.		

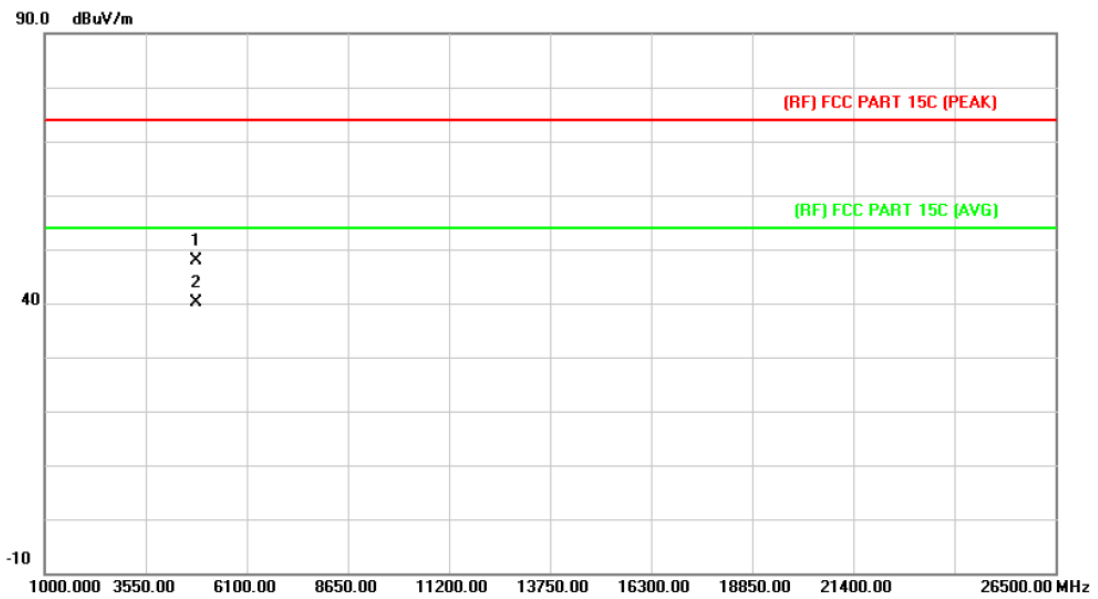

No.	Mk.	Freq.	Reading Level	Correct Factor	Measurement	Limit	Over	Detector
		MHz	dBuV	dB/m	dBuV/m	dBuV/m	dB	
1		4823.369	34.22	13.56	47.78	74.00	-26.22	peak
2	*	4823.654	26.56	13.56	40.12	54.00	-13.88	AVG

Emission Level= Read Level+ Correct Factor

EUT:	Gurubook 5/MID	Model Name :	GURUBOOK5
Temperature:	25 °C	Relative Humidity:	55%
Test Voltage:	AC 120V/60 Hz		
Ant. Pol.	Vertical		
Test Mode:	TX N(HT40) Mode 2422MHz		
Remark:	No report for the emission which more than 10 dB below the prescribed limit.		

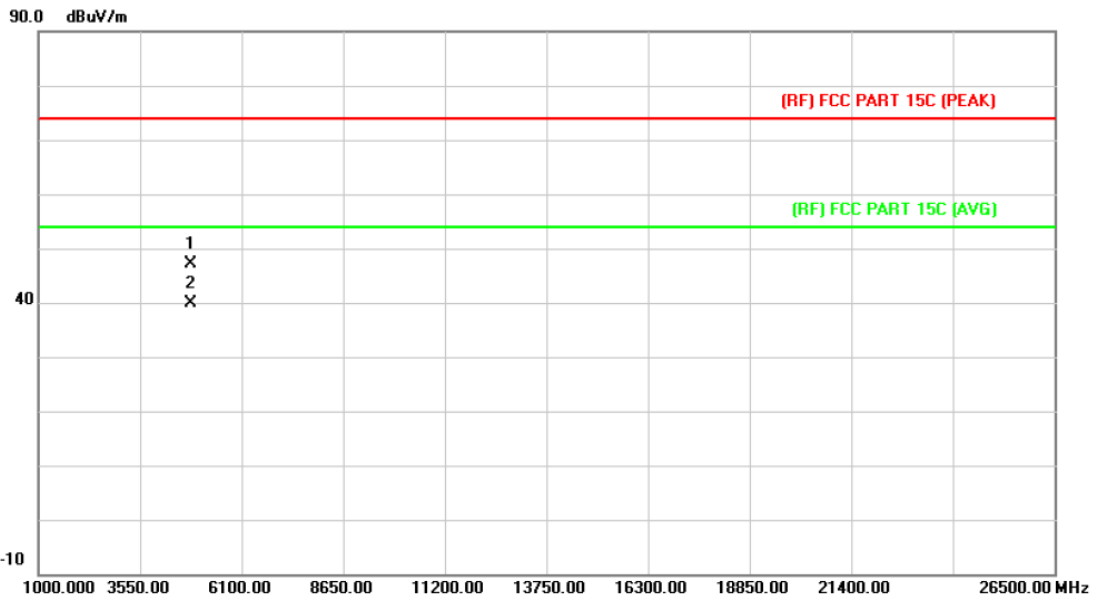

No.	Mk.	Freq.	Reading Level	Correct Factor	Measurement	Limit	Over	Detector
		MHz	dBuV	dB/m	dBuV/m	dBuV/m	dB	
1		4823.398	33.49	13.56	47.05	74.00	-26.95	peak
2	*	4824.354	26.28	13.56	39.84	54.00	-14.16	AVG

Emission Level= Read Level+ Correct Factor

EUT:	Gurubook 5/MID	Model Name :	GURUBOOK5
Temperature:	25 °C	Relative Humidity:	55%
Test Voltage:	AC 120V/60 Hz		
Ant. Pol.	Horizontal		
Test Mode:	TX N(HT40) Mode 2437MHz		
Remark:	No report for the emission which more than 10 dB below the prescribed limit.		

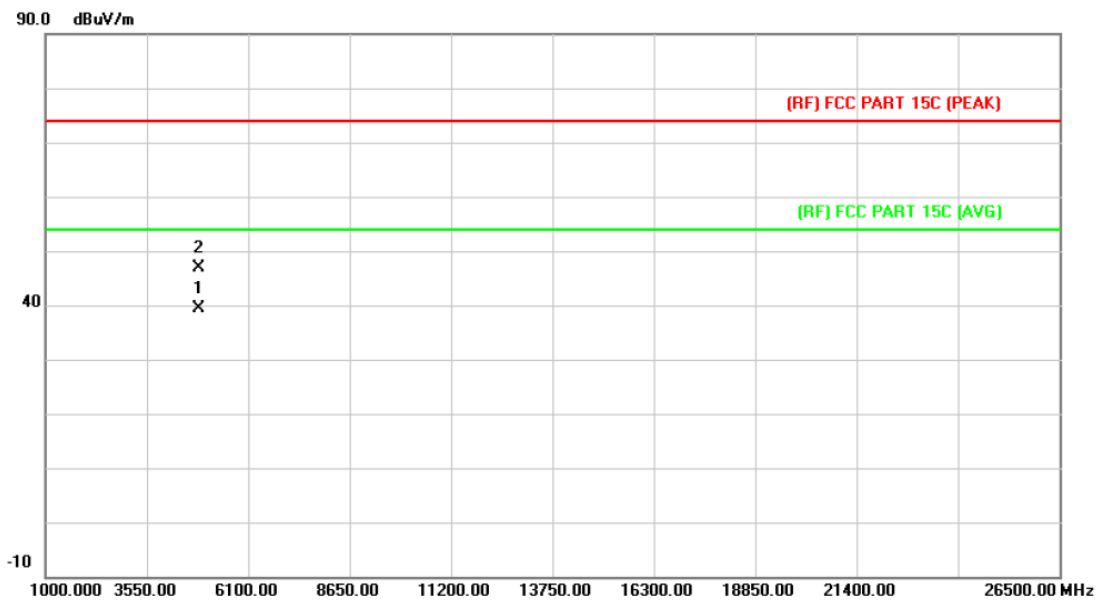

No.	Mk.	Freq.	Reading Level	Correct Factor	Measurement	Limit	Over	Detector
		MHz	dBuV	dB/m	dBuV/m	dBuV/m	dB	
1	*	4873.647	25.48	13.86	39.34	54.00	-14.66	AVG
2		4873.762	33.01	13.86	46.87	74.00	-27.13	peak

Emission Level= Read Level+ Correct Factor

EUT:	Gurubook 5/MID	Model Name :	GURUBOOK5
Temperature:	25 °C	Relative Humidity:	55%
Test Voltage:	AC 120V/60 Hz		
Ant. Pol.	Vertical		
Test Mode:	TX N(HT40) Mode 2437MHz		
Remark:	No report for the emission which more than 10 dB below the prescribed limit.		

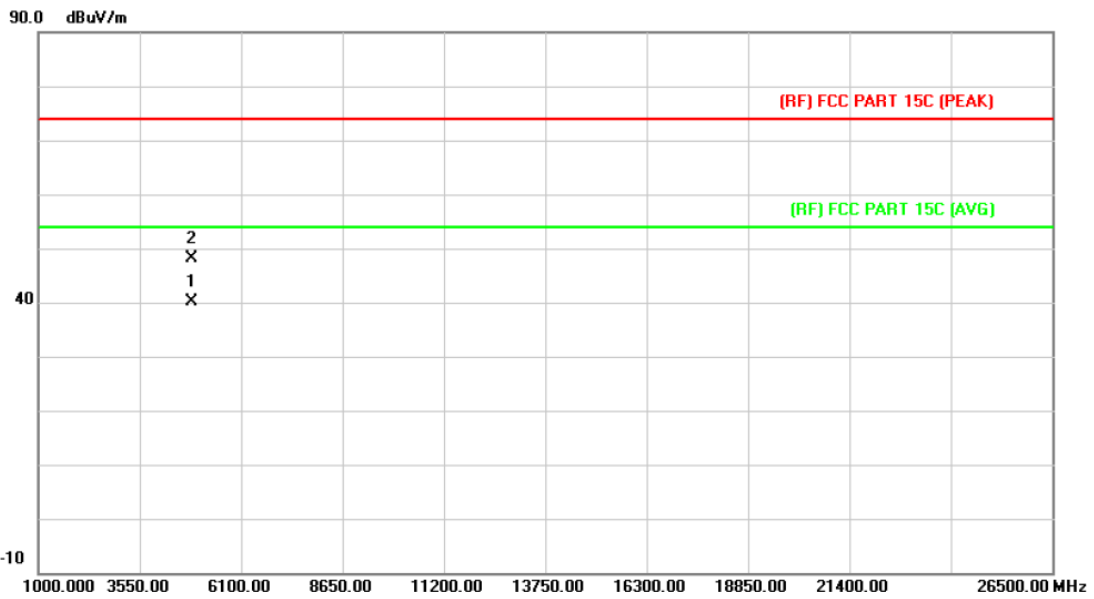

No.	Mk.	Freq. MHz	Reading Level dBuV	Correct Factor dB/m	Measure- ment dBuV/m	Limit dBuV/m	Over dB	Detector
1	*	4874.124	26.20	13.86	40.06	54.00	-13.94	AVG
2		4874.145	34.27	13.86	48.13	74.00	-25.87	peak

Emission Level= Read Level+ Correct Factor

EUT:	Gurubook 5/MID	Model Name :	GURUBOOK5
Temperature:	25 °C	Relative Humidity:	55%
Test Voltage:	AC 120V/60 Hz		
Ant. Pol.	Horizontal		
Test Mode:	TX N(HT40) Mode 2452MHz		
Remark:	No report for the emission which more than 10 dB below the prescribed limit.		

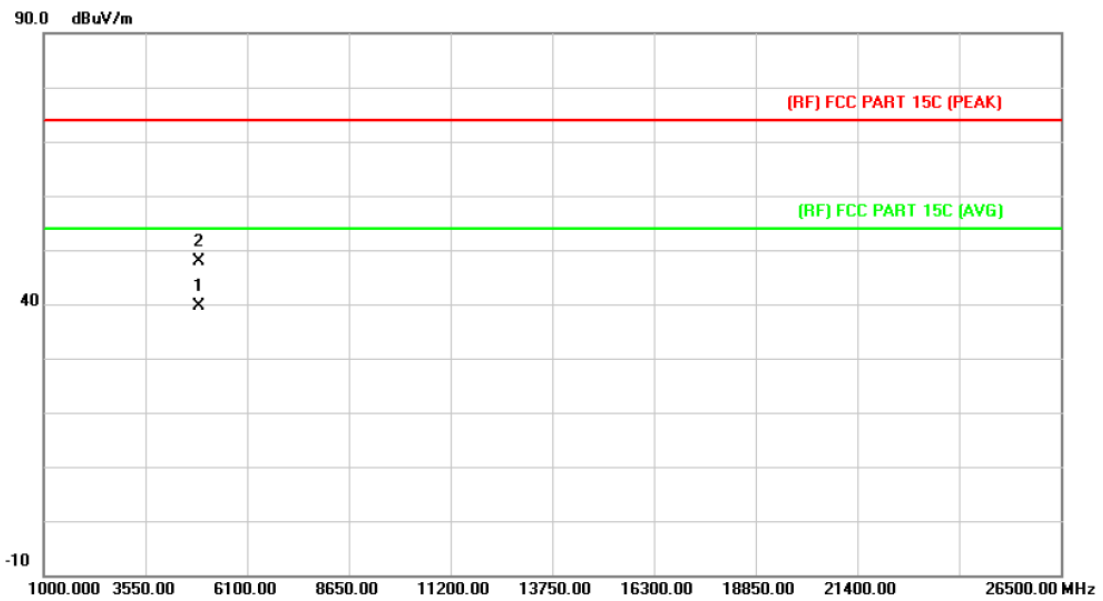

No.	Mk.	Freq.	Reading Level	Correct Factor	Measurement	Limit	Over	Detector
		MHz	dBuV	dB/m	dBuV/m	dBuV/m	dB	
1	*	4903.124	25.55	14.03	39.58	54.00	-14.42	AVG
2		4903.742	33.82	14.03	47.85	74.00	-26.15	peak

Emission Level= Read Level+ Correct Factor

EUT:	Gurubook 5/MID	Model Name :	GURUBOOK5
Temperature:	25 °C	Relative Humidity:	55%
Test Voltage:	AC 120V/60 Hz		
Ant. Pol.	Vertical		
Test Mode:	TX N(HT40) Mode 2452MHz		
Remark:	No report for the emission which more than 10 dB below the prescribed limit.		

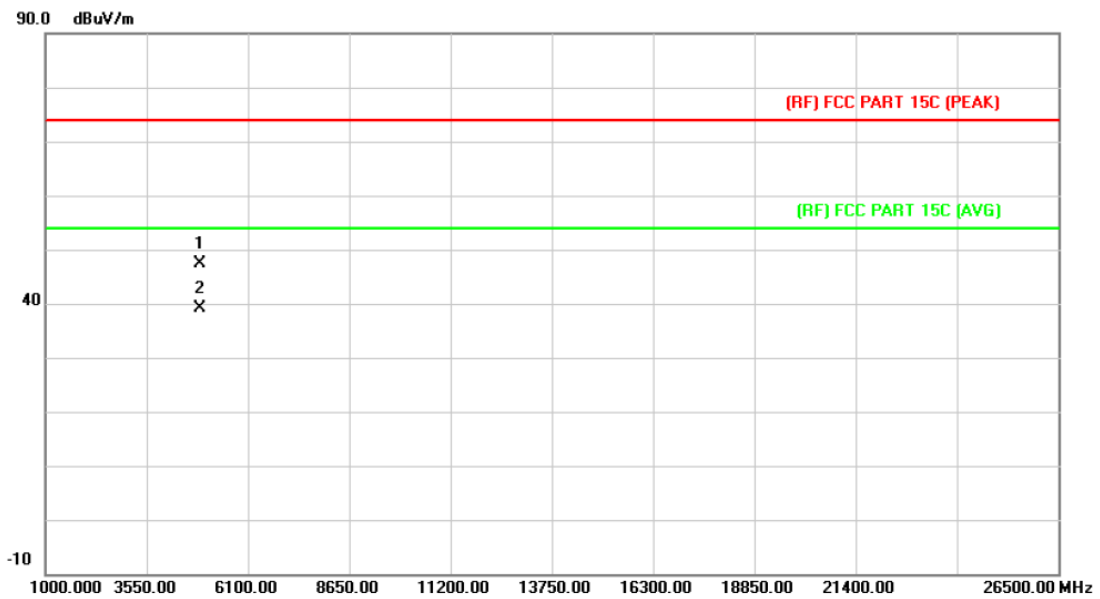

No.	Mk.	Freq. MHz	Reading Level dBuV	Correct Factor dB/m	Measure- ment dBuV/m	Limit dBuV/m	Over dB	Detector
1		4903.614	33.31	14.03	47.34	74.00	-26.66	peak
2	*	4903.644	25.02	14.03	39.05	54.00	-14.95	AVG

Emission Level= Read Level+ Correct Factor

5. Restricted Bands Requirement

5.1 Test Standard and Limit

5.1.1 Test Standard

FCC Part 15.209 FCC Part 15.205

5.1.2 Test Limit

Restricted Frequency Band (MHz)	Class B (dBuV/m)(at 3 M)	
	Peak	Average
2310 ~2390	74	54
2483.5 ~2500	74	54

5.2 Test Setup

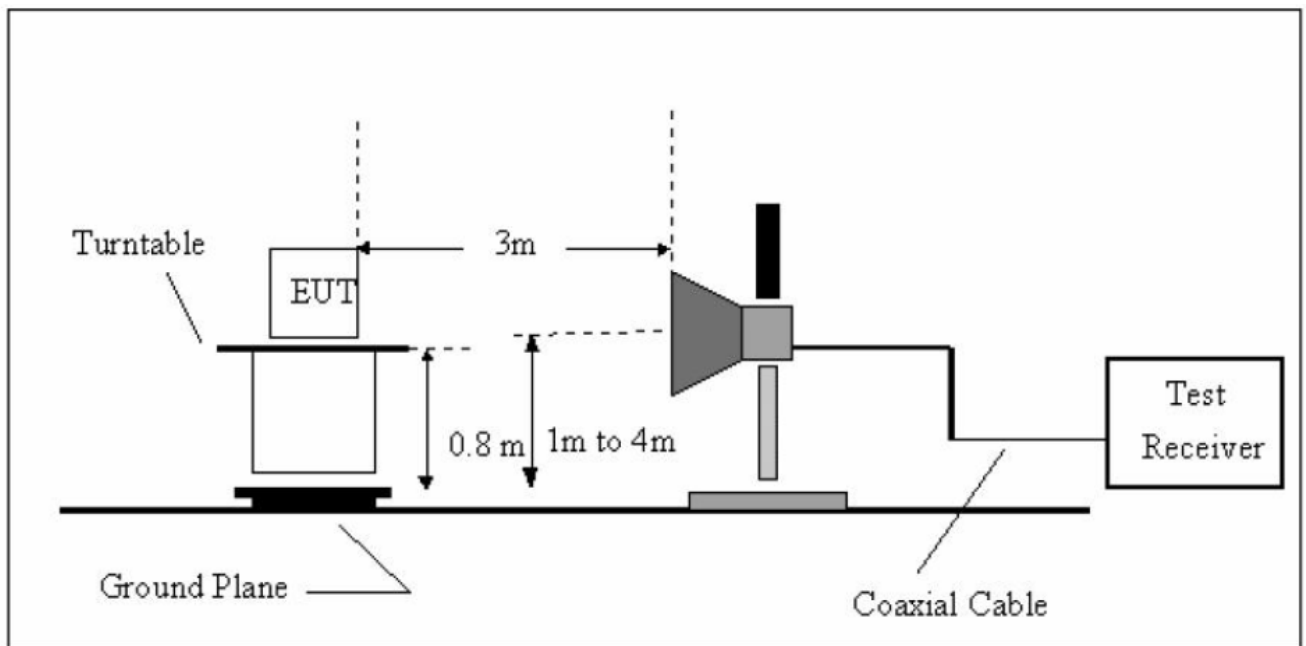

5.3 Test Procedure

- (1) The measuring distance of 3m shall be used for measurements at frequency up to 1GHz and above 1 GHz. The EUT was placed on a rotating 0.8m high above ground, the table was rotated 360 degrees to determine the position of the highest radiation.
- (2) The Test antenna shall vary between 1m and 4m, Both Horizontal and Vertical antenna are set to make measurement.
- (3) The initial step in collecting conducted emission data is a spectrum analyzer peak detector mode pre-scanning the measurement frequency range. Significant peaks are then marked and then Quasi Peak detector mode re-measured.
- (4) If the Peak Mode measured value compliance with and lower than Quasi Peak Mode Limit

Bellow 1 GHz, the EUT shall be deemed to meet QP Limits and then no additional QP Mode measurement performed. But the Peak Value and average value both need to comply with applicable limit above 1 GHz.

- (5) (5) Testing frequency range below 1GHz the measuring instrument use VBW=120 kHz with Quasi-peak detection.
- (6) Testing frequency range above 1GHz the measuring instrument use RBW=1 MHz and VBW=3 MHz with Peak Detector for Peak Values, and use RBW=1 MHz and VBW=10 Hz with Peak Detector for Average Values.
- (7) For the actual test configuration, please see the test setup photo.

5.4 EUT Operating Condition

The Equipment Under Test was set to Continual Transmitting in maximum power.

5.5 Test Equipment

Equipment	Manufacturer	Model No.	Serial No.	Last Cal.	Cal. Due Date
Spectrum Analyzer	Agilent	E4407B	MY45106456	Mar. 20, 2014	Mar. 19, 2015
Spectrum Analyzer	Rohde & Schwarz	FSP30	DE25181	Aug. 08, 2014	Aug. 07, 2015
EMI Test Receiver	Rohde & Schwarz	ESCI	101165	Aug. 08, 2014	Aug. 07, 2015
Bilog Antenna	ETS-LINDGREN	3142E	00117537	Mar. 07, 2014	Mar.06, 2015
Bilog Antenna	ETS-LINDGREN	3142E	00117542	Mar. 07, 2014	Mar.06, 2015
Horn Antenna	ETS-LINDGREN	3117	00143207	Mar. 07, 2014	Mar.06, 2015
Horn Antenna	ETS-LINDGREN	3117	00143209	Mar. 07, 2014	Mar.06, 2015
Pre-amplifier	HP	11909A	185903	Mar. 07, 2014	Mar.06, 2015
Pre-amplifier	HP	8447B	3008A00849	Mar. 07, 2014	Mar.06, 2015
Cable	HUBER+SUHNER	100	SUCOFLEX	Mar. 07, 2014	Mar.06, 2015
Signal Generator	Rohde & Schwarz	SML03	IKW682-054	Feb. 11, 2014	Feb.10, 2015
Positioning Controller	ETS-LINDGREN	2090	N/A	N/A	N/A

5.6 Test Data

Please see the next page.

(1) Radiation Test

EUT:	Gurubook 5/MID	Model Name :	GURUBOOK5
Temperature:	25 °C	Relative Humidity:	55%
Test Voltage:	AC 120V/60 Hz		
Ant. Pol.	Horizontal		
Test Mode:	TX B Mode 2412MHz		
Remark:	N/A		

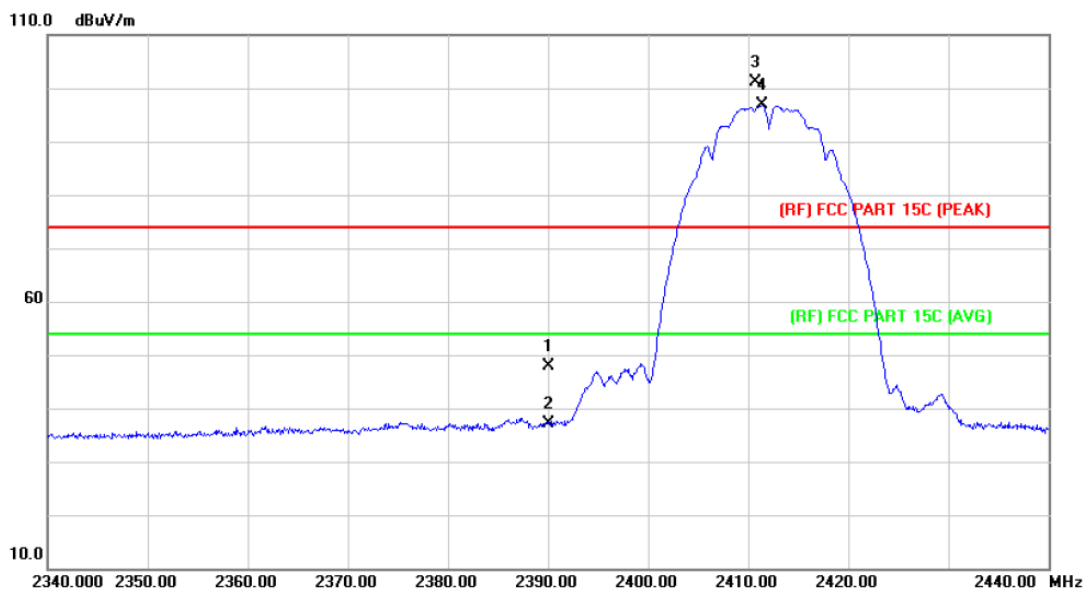

No.	Mk.	Freq.	Reading Level	Correct Factor	Measurement	Limit	Over
		MHz	dBuV	dB/m	dBuV/m	dBuV/m	dB Detector
1		2390.000	47.14	0.77	47.91	74.00	-26.09 peak
2		2390.000	36.36	0.77	37.13	54.00	-16.87 AVG
3	X	2410.700	100.28	0.86	101.14	Fundamental Frequency	peak
4	*	2411.400	95.90	0.86	96.76	Fundamental Frequency	AVG

Emission Level= Read Level+ Correct Factor

EUT:	Gurubook 5/MID	Model Name :	GURUBOOK5
Temperature:	25 °C	Relative Humidity:	55%
Test Voltage:	AC 120V/60 Hz		
Ant. Pol.	Vertical		
Test Mode:	TX B Mode 2412MHz		
Remark:	N/A		

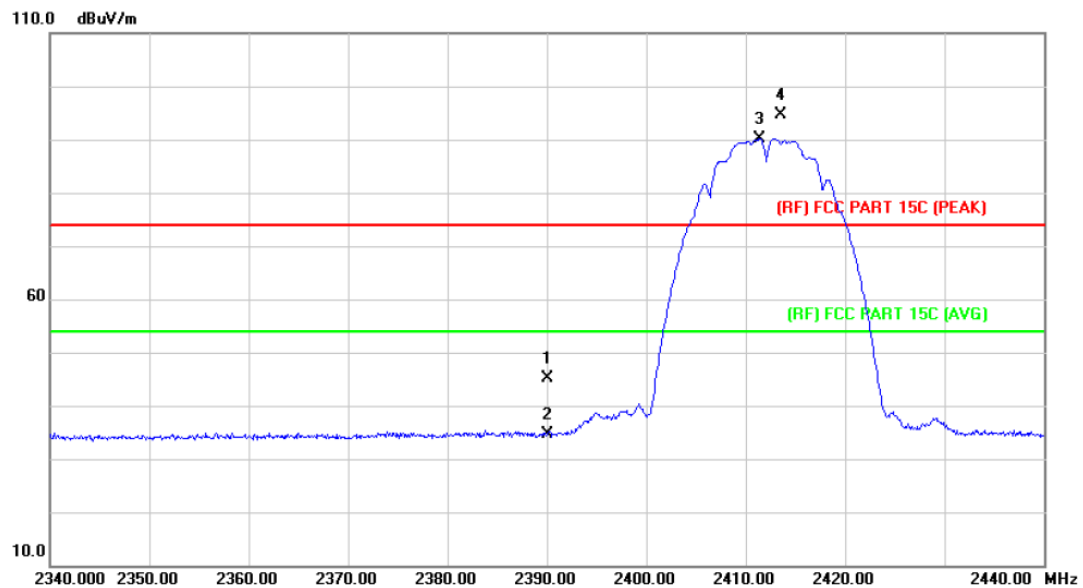

No.	Mk.	Freq. MHz	Reading Level dBuV	Correct Factor dB/m	Measure- ment dBuV/m	Limit dBuV/m	Over dB	Detector
1		2390.000	44.41	0.77	45.18	74.00	-28.82	peak
2		2390.000	33.74	0.77	34.51	54.00	-19.49	AVG
3	*	2411.400	89.33	0.86	90.19	Fundamental Frequency		AVG
4	X	2413.500	93.87	0.86	94.73	Fundamental Frequency		peak

Emission Level= Read Level+ Correct Factor

EUT:	Gurubook 5/MID	Model Name :	GURUBOOK5
Temperature:	25 °C	Relative Humidity:	55%
Test Voltage:	AC 120V/60 Hz		
Ant. Pol.	Horizontal		
Test Mode:	TX B Mode 2462MHz		
Remark:	N/A		

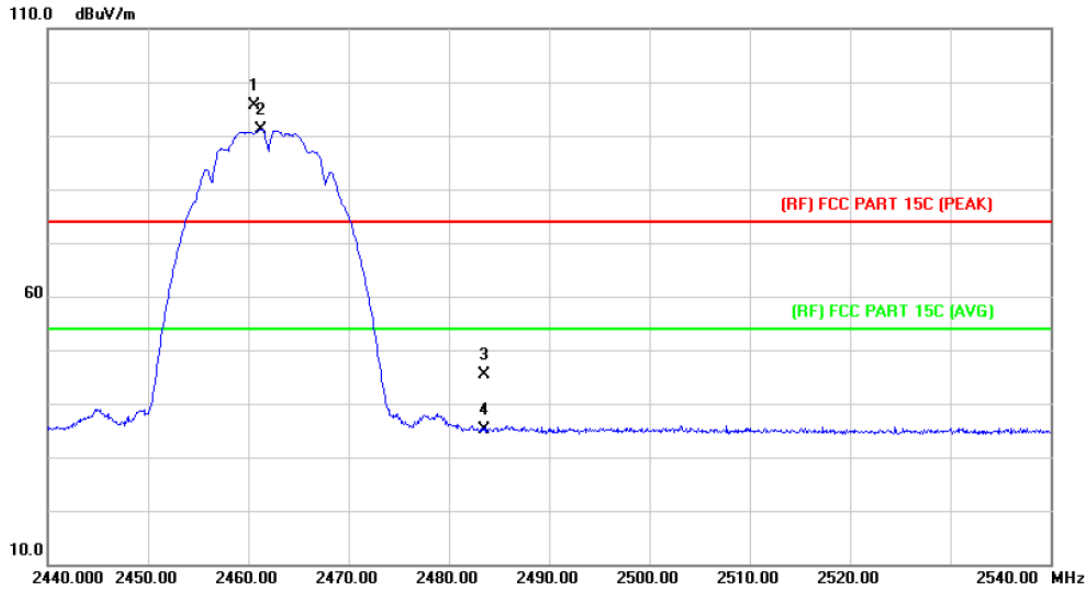

No.	Mk.	Freq. MHz	Reading Level dBuV	Correct Factor dB/m	Measure- ment dBuV/m	Limit dBuV/m	Over dB	Detector
1	X	2460.600	94.55	1.06	95.61	Fundamental Frequency		peak
2	*	2461.300	90.10	1.07	91.17	Fundamental Frequency		AVG
3		2483.500	44.32	1.17	45.49	74.00	-28.51	peak
4		2483.500	33.86	1.17	35.03	54.00	-18.97	AVG

Emission Level= Read Level+ Correct Factor

EUT:	Gurubook 5/MID	Model Name :	GURUBOOK5
Temperature:	25 °C	Relative Humidity:	55%
Test Voltage:	AC 120V/60 Hz		
Ant. Pol.	Vertical		
Test Mode:	TX B Mode 2462MHz		
Remark:	N/A		

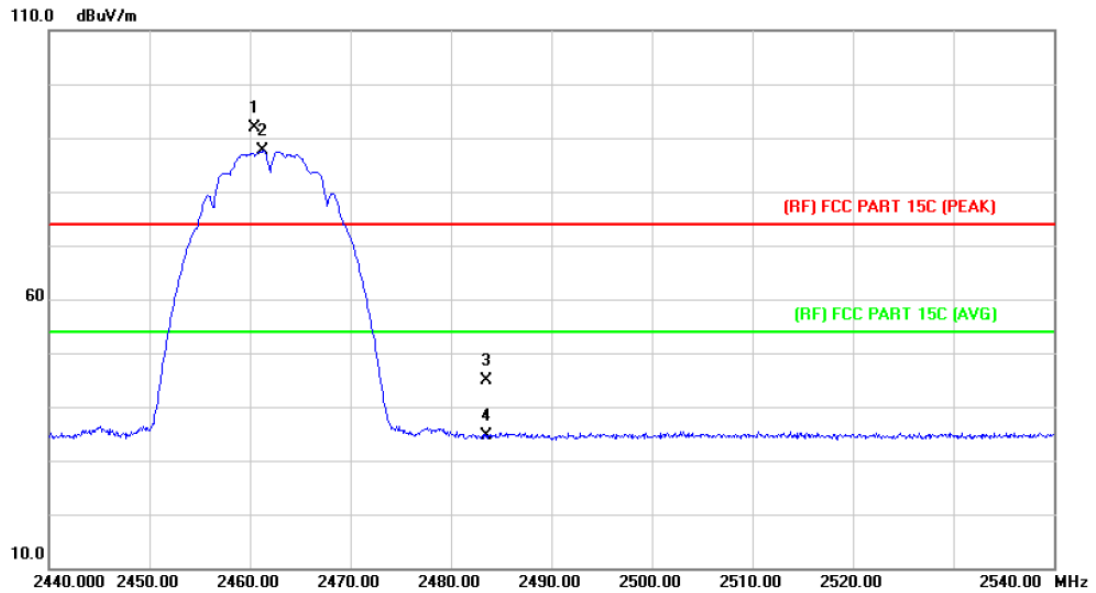

No.	Mk.	Freq. MHz	Reading Level dBuV	Correct Factor dB/m	Measure- ment dBuV/m	Limit dBuV/m	Over dB	Detector
1	X	2460.500	90.89	1.06	91.95	Fundamental Frequency		peak
2	*	2461.300	86.52	1.07	87.59	Fundamental Frequency		AVG
3		2483.500	43.70	1.17	44.87	74.00	-29.13	peak
4		2483.500	33.52	1.17	34.69	54.00	-19.31	AVG

Emission Level= Read Level+ Correct Factor

EUT:	Gurubook 5/MID	Model Name :	GURUBOOK5
Temperature:	25 °C	Relative Humidity:	55%
Test Voltage:	AC 120V/60 Hz		
Ant. Pol.	Horizontal		
Test Mode:	TX G Mode 2412MHz		
Remark:	N/A		

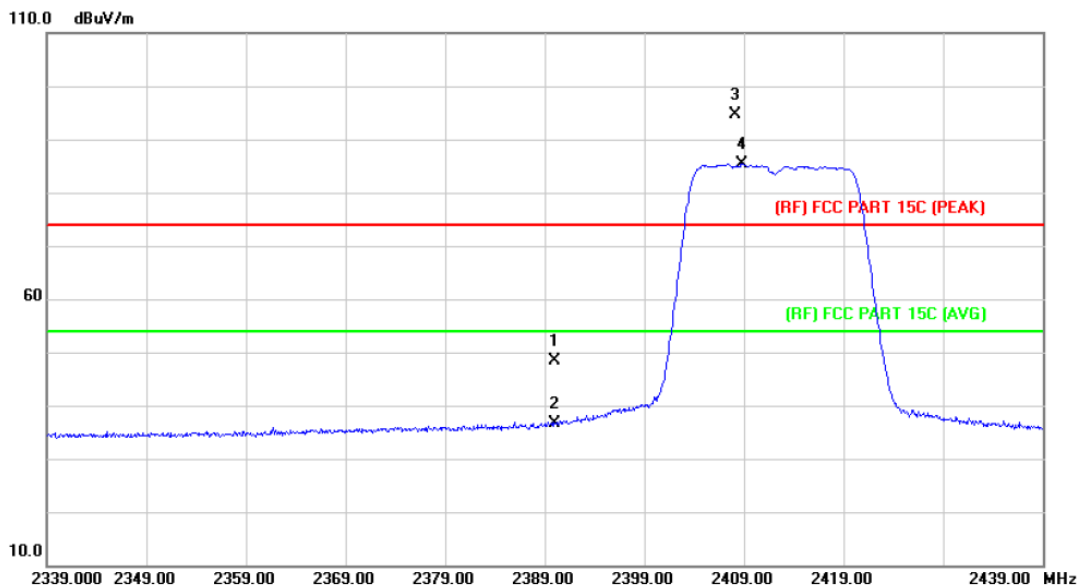

No.	Mk.	Freq.	Reading Level	Correct Factor	Measurement	Limit	Over	Detector
		MHz	dBuV	dB/m	dBuV/m	dBuV/m	dB	
1		2390.000	47.73	0.77	48.50	74.00	-25.50	peak
2		2390.000	35.77	0.77	36.54	54.00	-17.46	AVG
3	X	2408.200	93.66	0.85	94.51	Fundamental Frequency		peak
4	*	2408.800	84.54	0.85	85.39	Fundamental Frequency		AVG

Emission Level= Read Level+ Correct Factor

EUT:	Gurubook 5/MID	Model Name :	GURUBOOK5
Temperature:	25 °C	Relative Humidity:	55%
Test Voltage:	AC 120V/60 Hz		
Ant. Pol.	Vertical		
Test Mode:	TX G Mode 2412MHz		
Remark:	N/A		

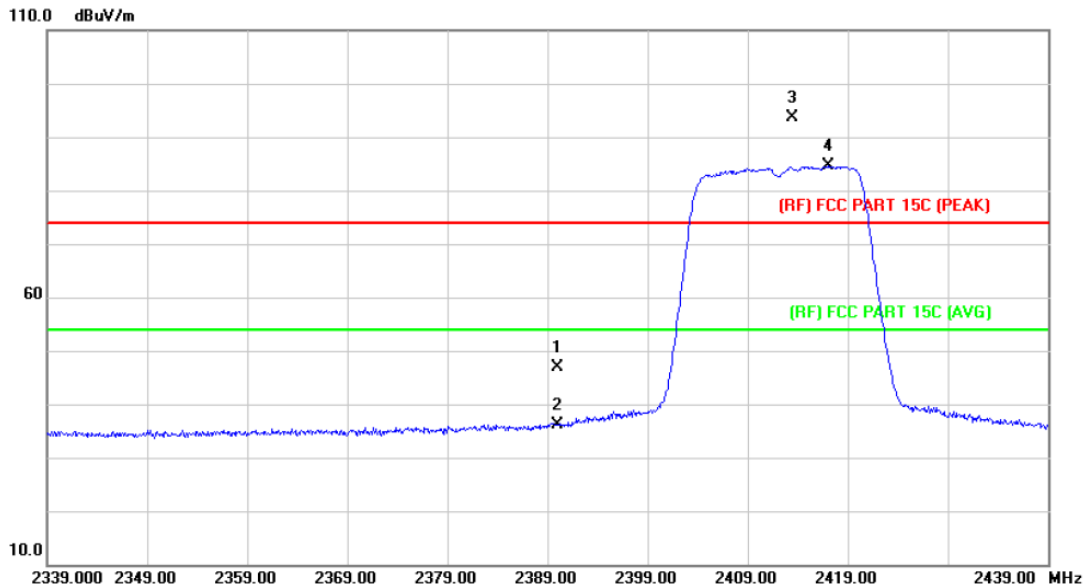

No.	Mk.	Freq.	Reading Level	Correct Factor	Measurement	Limit	Over	Detector
		MHz	dBuV	dB/m	dBuV/m	dBuV/m	dB	
1		2390.000	46.06	0.77	46.83	74.00	-27.17	peak
2		2390.000	35.37	0.77	36.14	54.00	-17.86	AVG
3	X	2413.500	92.84	0.86	93.70	Fundamental Frequency		peak
4	*	2417.000	83.66	0.88	84.54	Fundamental Frequency		AVG

Emission Level= Read Level+ Correct Factor

EUT:	Gurubook 5/MID	Model Name :	GURUBOOK5
Temperature:	25 °C	Relative Humidity:	55%
Test Voltage:	AC 120V/60 Hz		
Ant. Pol.	Horizontal		
Test Mode:	TX G Mode 2462MHz		
Remark:	N/A		

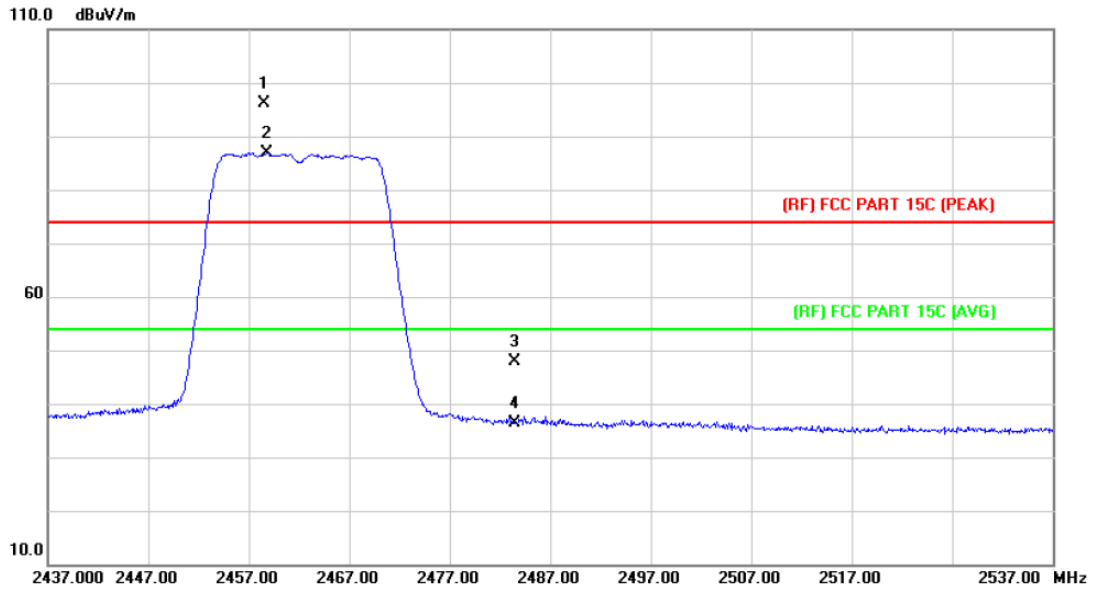

No.	Mk.	Freq. MHz	Reading Level dBuV	Correct Factor dB/m	Measure- ment dBuV/m	Limit dBuV/m	Over dB	Detector
1	X	2458.600	95.19	1.06	96.25	Fundamental Frequency		peak
2	*	2458.800	85.88	1.06	86.94	Fundamental Frequency		AVG
3		2483.500	46.62	1.17	47.79	74.00	-26.21	peak
4		2483.500	35.25	1.17	36.42	54.00	-17.58	AVG

Emission Level= Read Level+ Correct Factor

EUT:	Gurubook 5/MID	Model Name :	GURUBOOK5
Temperature:	25 °C	Relative Humidity:	55%
Test Voltage:	AC 120V/60 Hz		
Ant. Pol.	Vertical		
Test Mode:	TX G Mode 2462MHz		
Remark:	N/A		

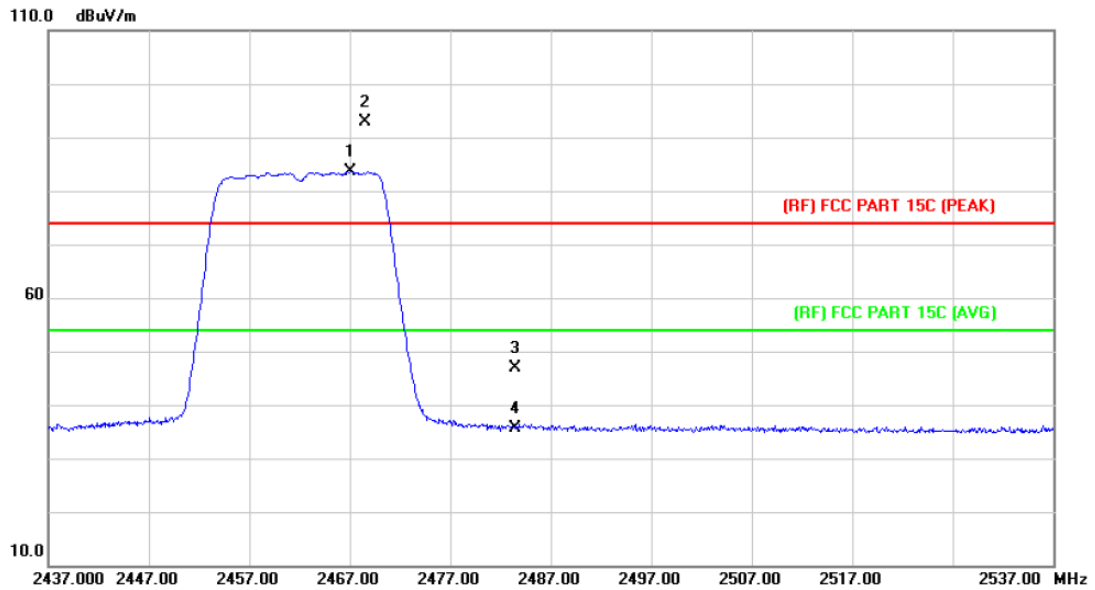

No.	Mk.	Freq. MHz	Reading Level dBuV	Correct Factor dB/m	Measure- ment dBuV/m	Limit dBuV/m	Over dB	Detector
1	*	2467.100	82.50	1.10	83.60	Fundamental Frequency		AVG
2	X	2468.500	91.71	1.11	92.82	Fundamental Frequency		peak
3		2483.500	45.61	1.17	46.78	74.00	-27.22	peak
4		2483.500	34.36	1.17	35.53	54.00	-18.47	AVG

Emission Level= Read Level+ Correct Factor

EUT:	Gurubook 5/MID	Model Name :	GURUBOOK5
Temperature:	25 °C	Relative Humidity:	55%
Test Voltage:	AC 120V/60 Hz		
Ant. Pol.	Horizontal		
Test Mode:	TX N(HT20) Mode 2412MHz		
Remark:	N/A		

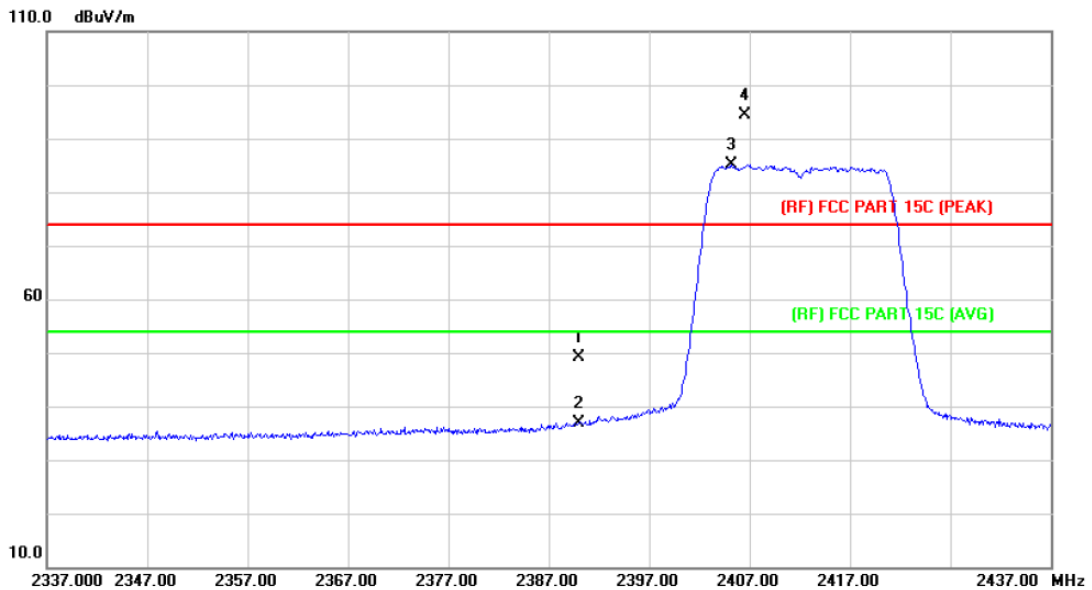

No.	Mk.	Freq. MHz	Reading Level dBuV	Correct Factor dB/m	Measure- ment dBuV/m	Limit dBuV/m	Over dB	Detector
1		2390.000	48.44	0.77	49.21	74.00	-24.79	peak
2		2390.000	36.12	0.77	36.89	54.00	-17.11	AVG
3	*	2405.200	84.22	0.84	85.06	Fundamental Frequency		AVG
4	X	2406.600	93.52	0.84	94.36	Fundamental Frequency		peak

Emission Level= Read Level+ Correct Factor

EUT:	Gurubook 5/MID	Model Name :	GURUBOOK5
Temperature:	25 °C	Relative Humidity:	55%
Test Voltage:	AC 120V/60 Hz		
Ant. Pol.	Vertical		
Test Mode:	TX N(HT20) Mode 2412MHz		
Remark:	N/A		

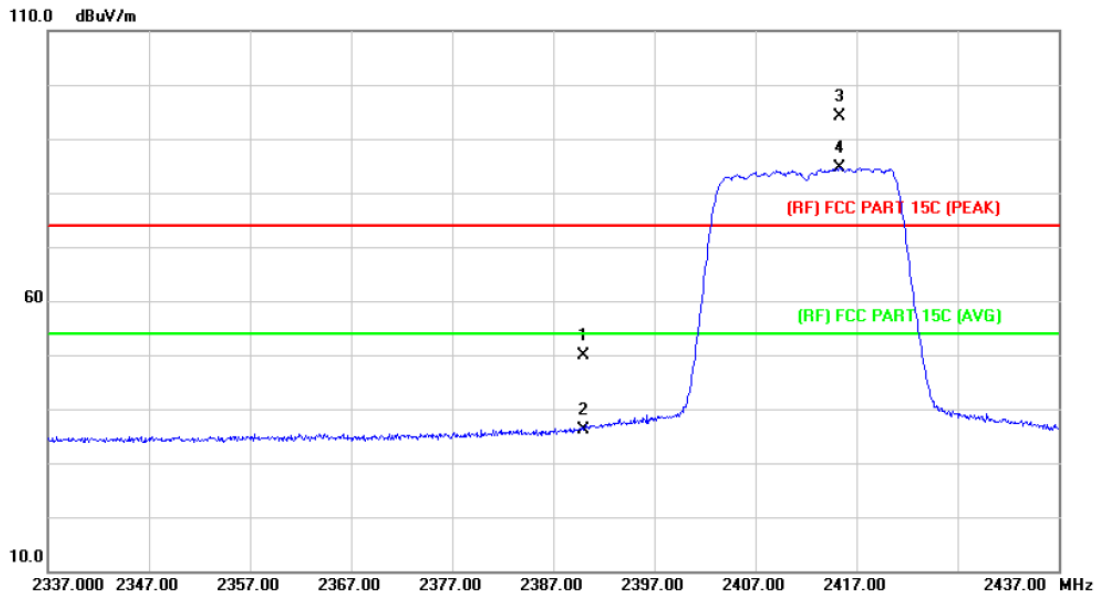

No.	Mk.	Freq. MHz	Reading Level dBuV	Correct Factor dB/m	Measure- ment dBuV/m	Limit dBuV/m	Over dB	Detector
1		2390.000	49.19	0.77	49.96	74.00	-24.04	peak
2		2390.000	35.47	0.77	36.24	54.00	-17.76	AVG
3	X	2415.300	93.16	0.88	94.04	Fundamental Frequency		peak
4	*	2415.300	83.71	0.88	84.59	Fundamental Frequency		AVG

Emission Level= Read Level+ Correct Factor

EUT:	Gurubook 5/MID	Model Name :	GURUBOOK5
Temperature:	25 °C	Relative Humidity:	55%
Test Voltage:	AC 120V/60 Hz		
Ant. Pol.	Horizontal		
Test Mode:	TX N(HT20) Mode 2462MHz		
Remark:	N/A		

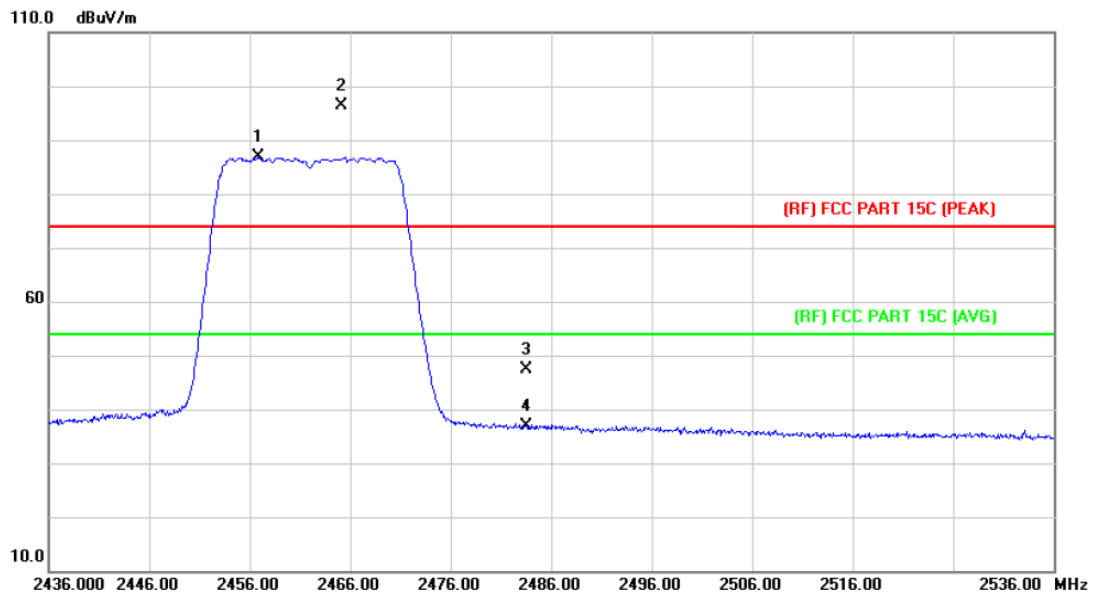

No.	Mk.	Freq. MHz	Reading Level dBuV	Correct Factor dB/m	Measure- ment dBuV/m	Limit dBuV/m	Over dB	Detector
1	*	2456.900	85.85	1.05	86.90	Fundamental Frequency		AVG
2	X	2465.200	95.28	1.09	96.37	Fundamental Frequency		peak
3		2483.500	46.26	1.17	47.43	74.00	-26.57	peak
4		2483.500	35.63	1.17	36.80	54.00	-17.20	AVG

Emission Level= Read Level+ Correct Factor

EUT:	Gurubook 5/MID	Model Name :	GURUBOOK5
Temperature:	25 °C	Relative Humidity:	55%
Test Voltage:	AC 120V/60 Hz		
Ant. Pol.	Vertical		
Test Mode:	TX N(HT20) Mode 2462MHz		
Remark:	N/A		

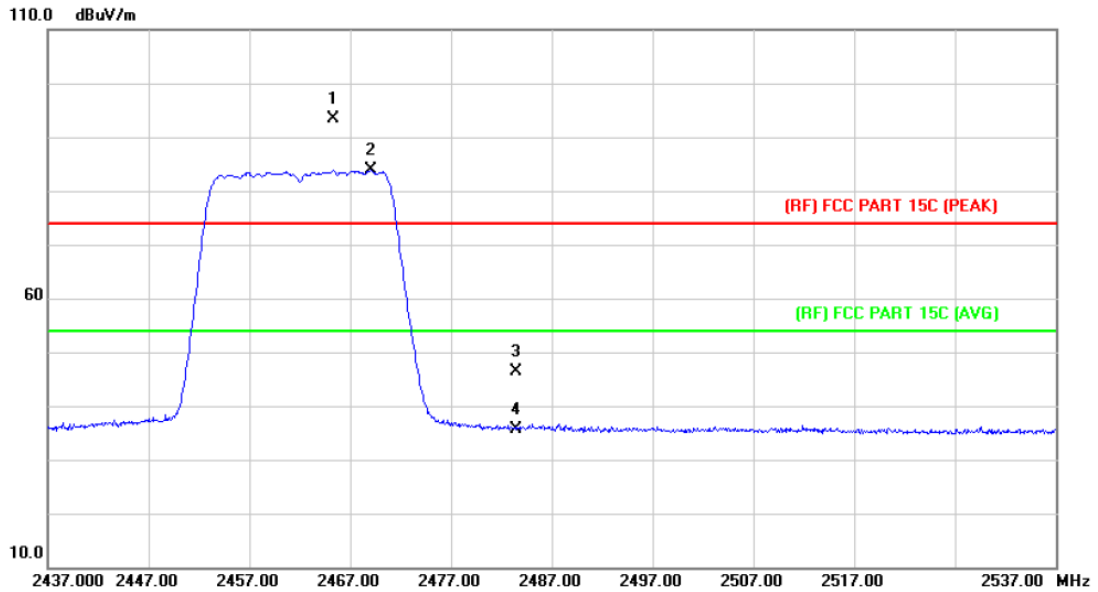

No.	Mk.	Freq. MHz	Reading Level dBuV	Correct Factor dB/m	Measure- ment dBuV/m	Limit dBuV/m	Over dB	Detector
1	X	2465.300	92.17	1.09	93.26	Fundamental Frequency		peak
2	*	2469.100	82.69	1.11	83.80	Fundamental Frequency		AVG
3		2483.500	45.15	1.17	46.32	74.00	-27.68	peak
4		2483.500	34.53	1.17	35.70	54.00	-18.30	AVG

Emission Level= Read Level+ Correct Factor

EUT:	Gurubook 5/MID	Model Name :	GURUBOOK5
Temperature:	25 °C	Relative Humidity:	55%
Test Voltage:	AC 120V/60 Hz		
Ant. Pol.	Horizontal		
Test Mode:	TX N(HT40) Mode 2422MHz		
Remark:	N/A		

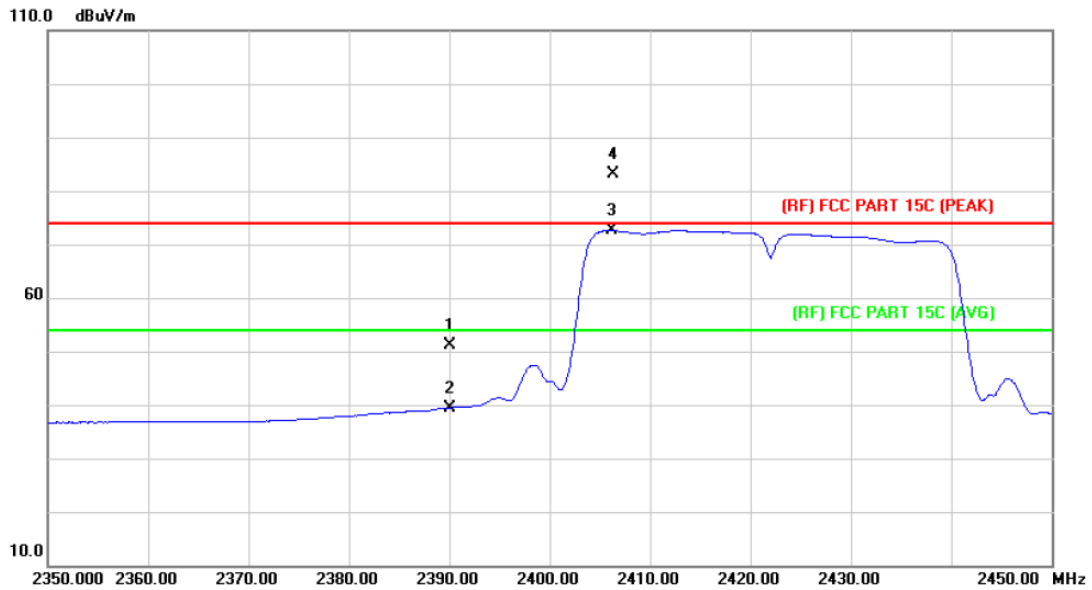

No.	Mk.	Freq. MHz	Reading Level dBuV	Correct Factor dB/m	Measure- ment dBuV/m	Limit dBuV/m	Over dB	Detector
1		2390.000	50.30	0.77	51.07	74.00	-22.93	peak
2		2390.000	38.63	0.77	39.40	54.00	-14.60	AVG
3	*	2406.200	71.86	0.84	72.70	Fundamental Frequency		AVG
4	X	2406.300	82.36	0.84	83.20	Fundamental Frequency		peak

Emission Level= Read Level+ Correct Factor

EUT:	Gurubook 5/MID	Model Name :	GURUBOOK5
Temperature:	25 °C	Relative Humidity:	55%
Test Voltage:	AC 120V/60 Hz		
Ant. Pol.	Vertical		
Test Mode:	TX N(HT40) Mode 2422MHz		
Remark:	N/A		

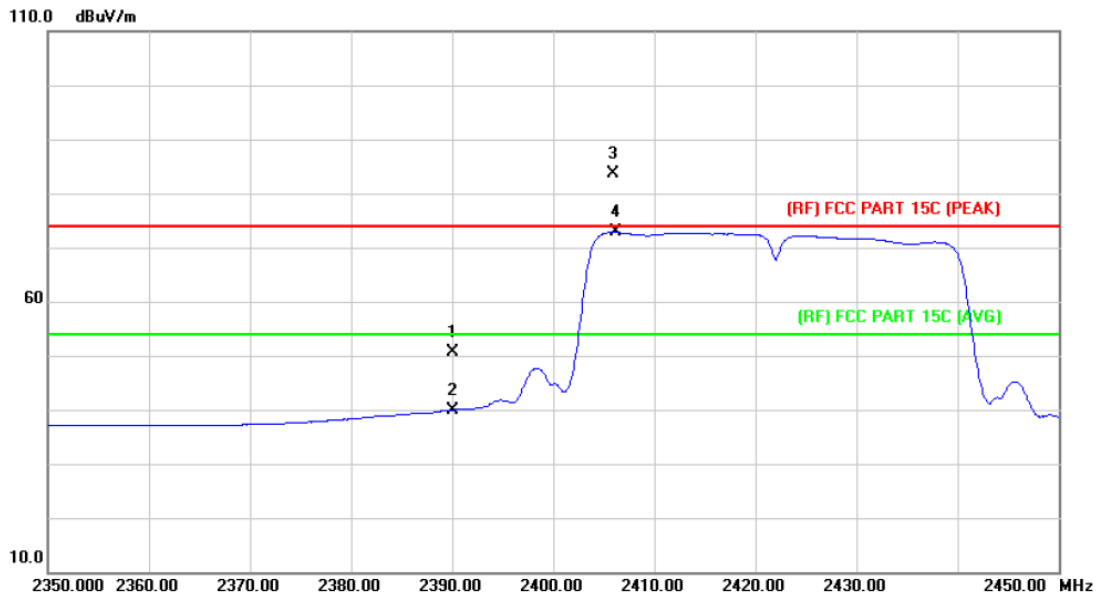

No.	Mk.	Freq. MHz	Reading Level dBuV	Correct Factor dB/m	Measure- ment dBuV/m	Limit dBuV/m	Over dB	Detector
1		2390.000	49.81	0.77	50.58	74.00	-23.42	peak
2		2390.000	39.11	0.77	39.88	54.00	-14.12	AVG
3	X	2405.900	82.81	0.84	83.65	Fundamental Frequency		peak
4	*	2406.200	72.05	0.84	72.89	Fundamental Frequency		AVG

Emission Level= Read Level+ Correct Factor

EUT:	Gurubook 5/MID	Model Name :	GURUBOOK5
Temperature:	25 °C	Relative Humidity:	55%
Test Voltage:	AC 120V/60 Hz		
Ant. Pol.	Horizontal		
Test Mode:	TX N(HT40) Mode 2452MHz		
Remark:	N/A		

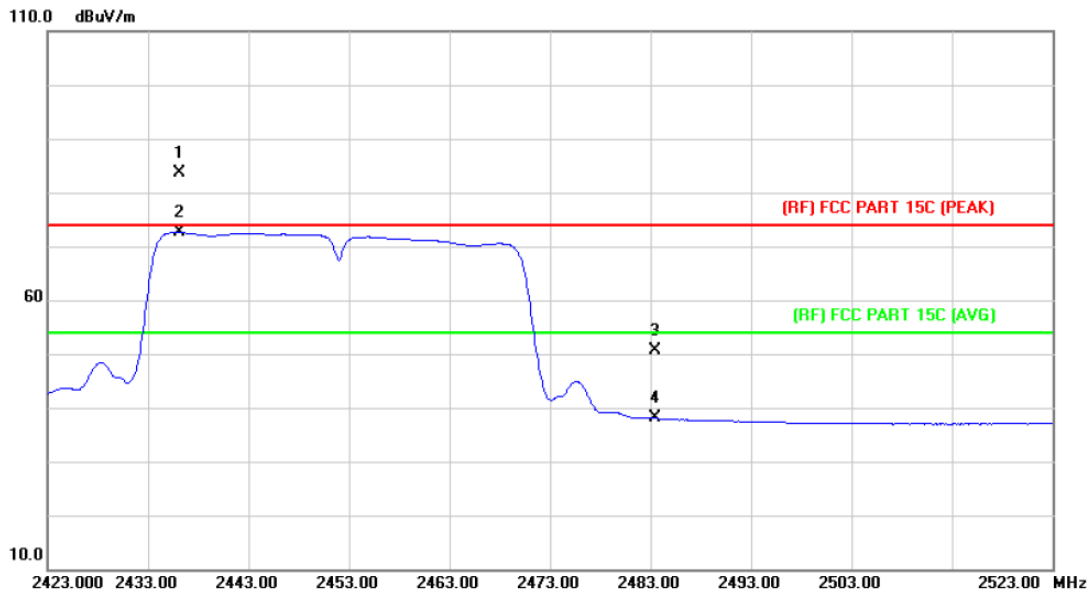

No.	Mk.	Freq. MHz	Reading Level dBuV	Correct Factor dB/m	Measure- ment dBuV/m	Limit dBuV/m	Over dB	Detector
1	X	2436.200	82.64	0.97	83.61	Fundamental Frequency		peak
2	*	2436.200	71.76	0.97	72.73	Fundamental Frequency		AVG
3		2483.500	49.47	1.17	50.64	74.00	-23.36	peak
4		2483.500	36.87	1.17	38.04	54.00	-15.96	AVG

Emission Level= Read Level+ Correct Factor

EUT:	Gurubook 5/MID	Model Name :	GURUBOOK5
Temperature:	25 °C	Relative Humidity:	55%
Test Voltage:	AC 120V/60 Hz		
Ant. Pol.	Vertical		
Test Mode:	TX N(HT40) Mode 2452MHz		
Remark:	N/A		

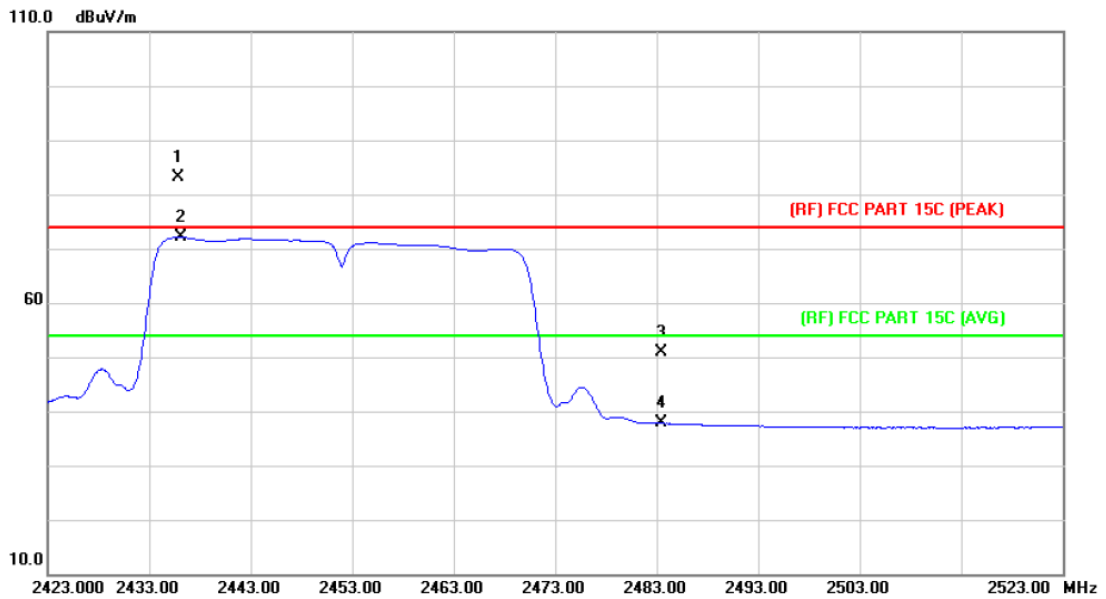

No.	Mk.	Freq. MHz	Reading Level dBuV	Correct Factor dB/m	Measure- ment dBuV/m	Limit dBuV/m	Over dB	Detector
1	X	2435.900	82.07	0.97	83.04	Fundamental Frequency		peak
2	*	2436.100	71.20	0.97	72.17	Fundamental Frequency		AVG
3		2483.500	49.69	1.17	50.86	74.00	-23.14	peak
4		2483.500	36.62	1.17	37.79	54.00	-16.21	AVG

Emission Level= Read Level+ Correct Factor

(2) Conducted Test

EUT:	Gurubook 5/MID	Model Name :	GURUBOOK5
Temperature:	25 °C	Relative Humidity:	55%
Test Voltage:	AC 120V/60 Hz		
Test Mode:	TX B Mode 2412MHz / TX B Mode 2462MHz		
Remark:	The EUT is programed in continuously transmitting mode		

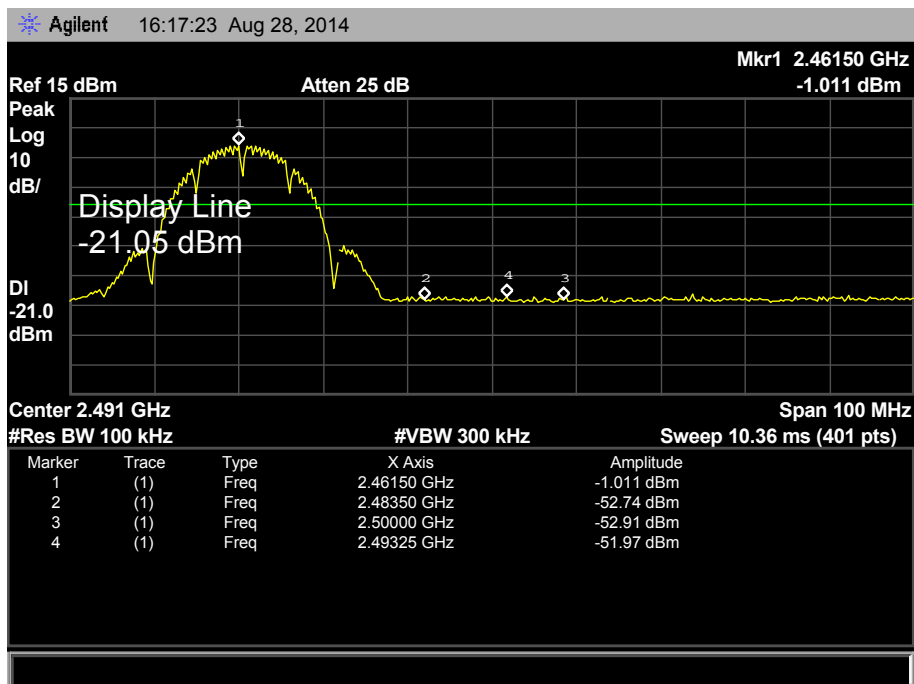
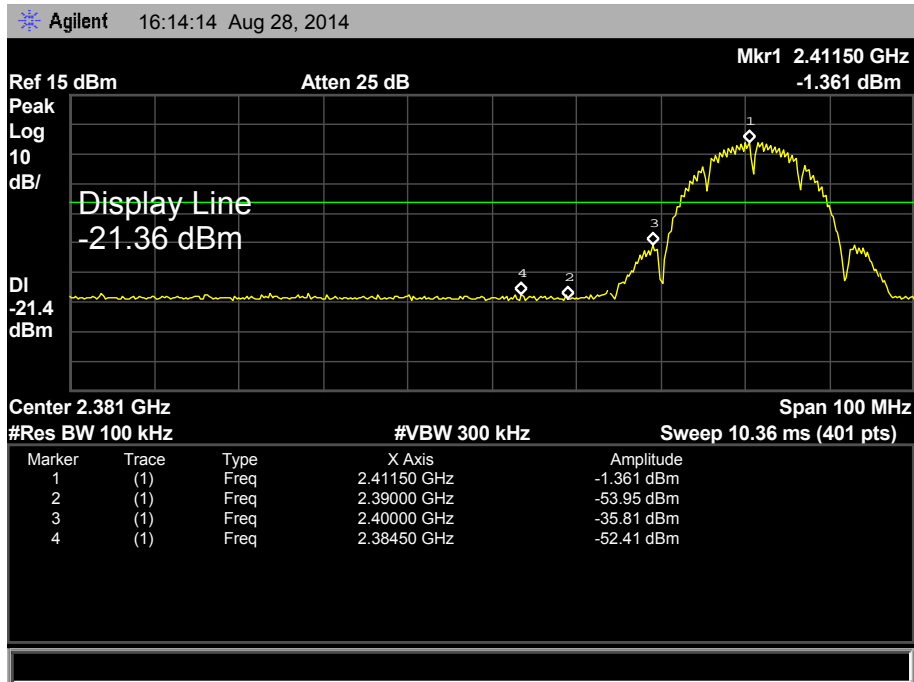

EUT:	Gurubook 5/MID	Model Name :	GURUBOOK5
Temperature:	25 °C	Relative Humidity:	55%
Test Voltage:	AC 120V/60 Hz		
Test Mode:	TX G Mode 2412MHz / TX G Mode 2462MHz		
Remark:	The EUT is programed in continuously transmitting mode		

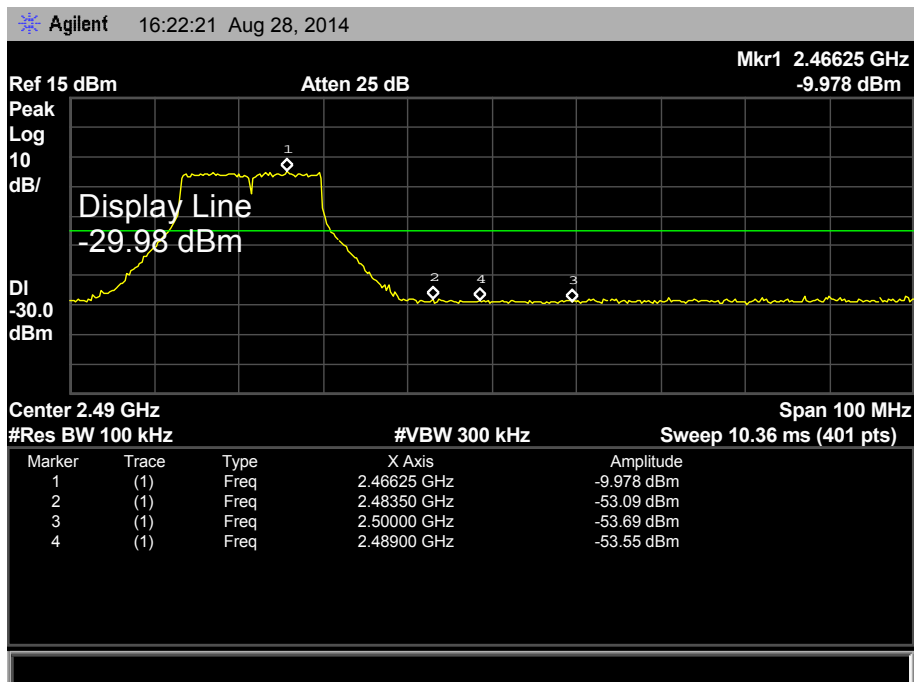
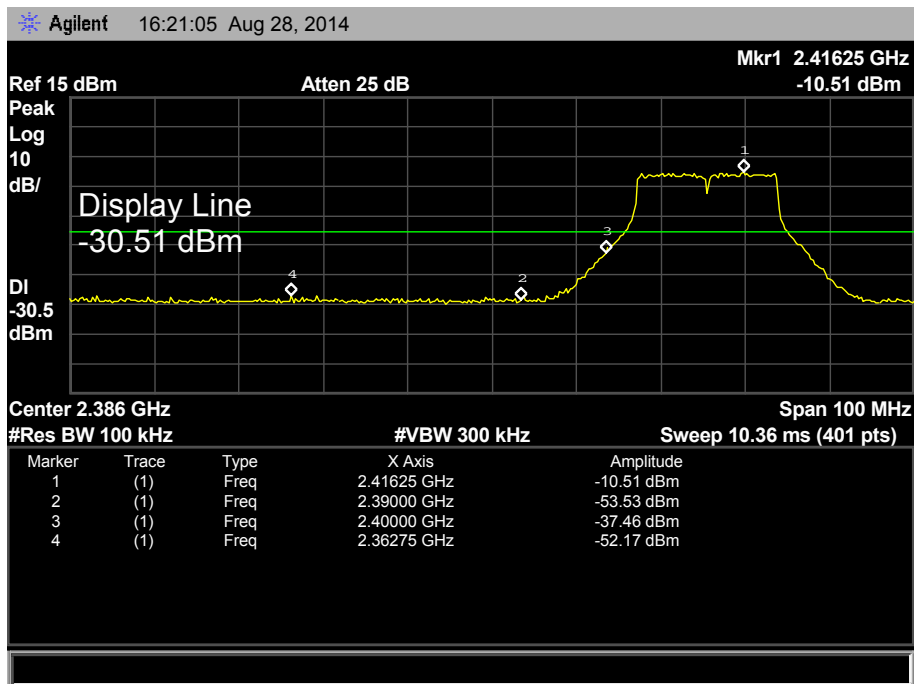

EUT:	Gurubook 5/MID	Model Name :	GURUBOOK5
Temperature:	25 °C	Relative Humidity:	55%
Test Voltage:	AC 120V/60 Hz		
Test Mode:	TX N(HT20) Mode 2412MHz / TX N(HT20) Mode 2462MHz		
Remark:	The EUT is programed in continuously transmitting mode		

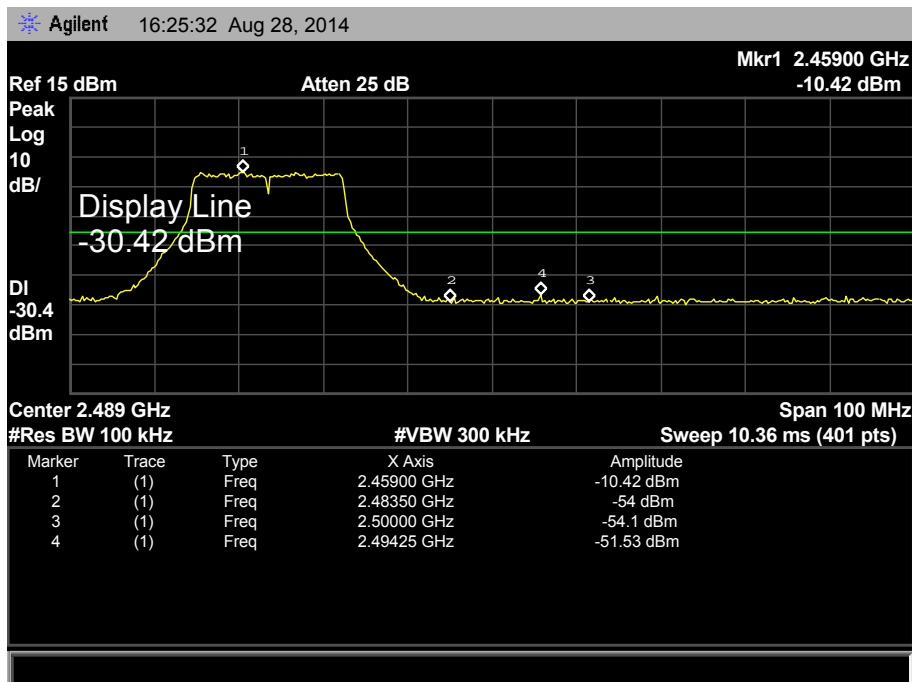
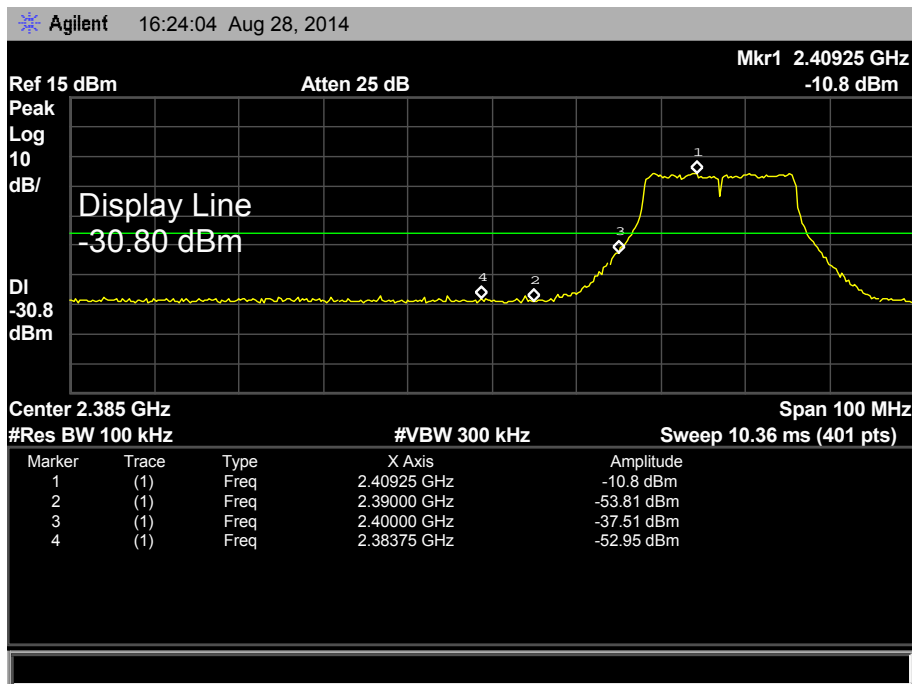

EUT:	Gurubook 5/MID	Model Name :	GURUBOOK5
Temperature:	25 °C	Relative Humidity:	55%
Test Voltage:	AC 120V/60 Hz		
Test Mode:	TX N(HT40) Mode 2422MHz / TX N(HT40) Mode 2452MHz		
Remark:	The EUT is programed in continuously transmitting mode		

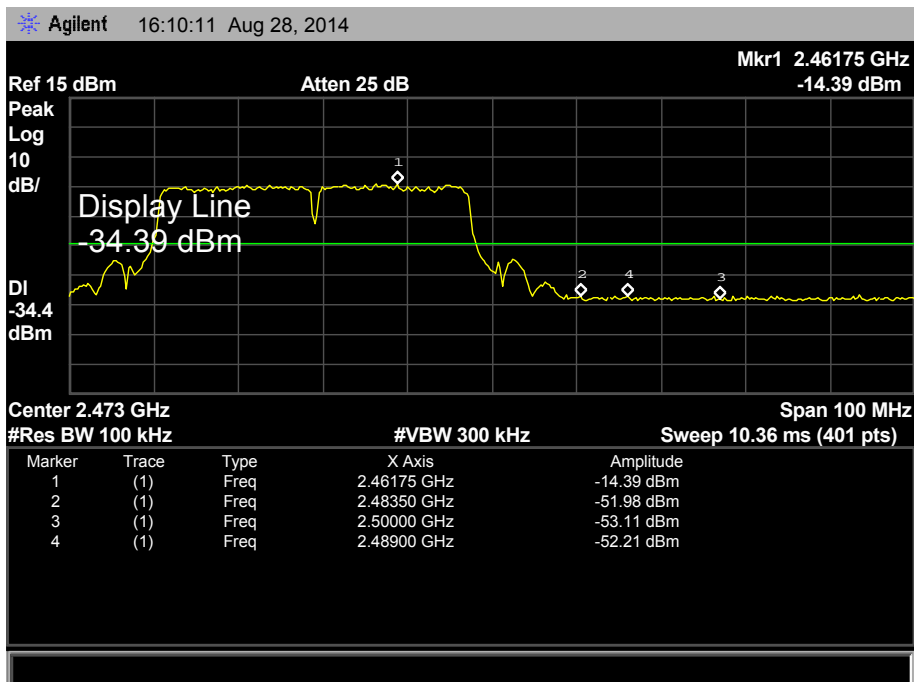
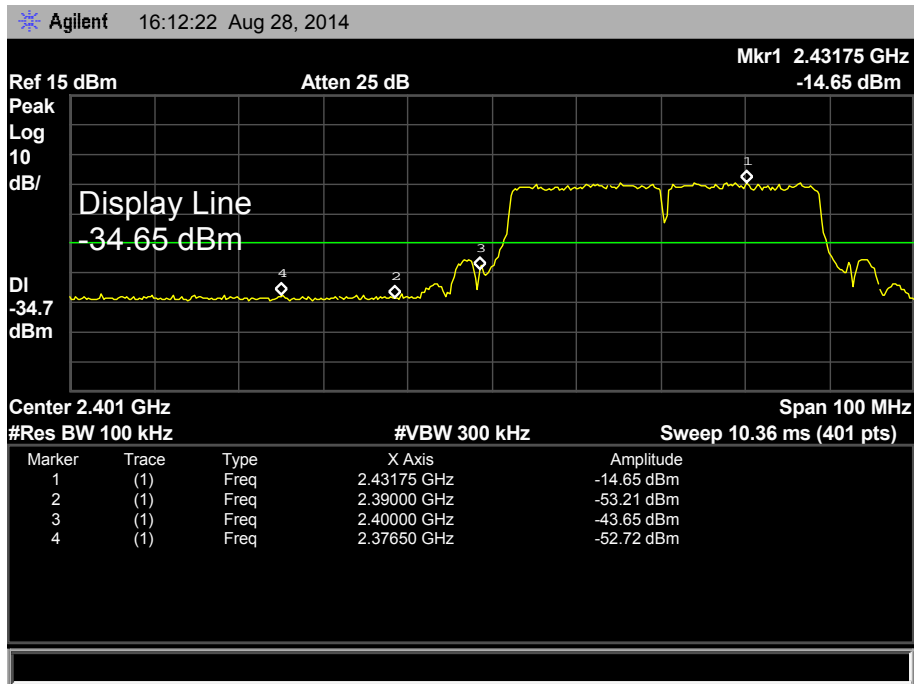

6. Bandwidth Test

6.1 Test Standard and Limit

6.1.1 Test Standard

FCC Part 15.247 (a)(2)

6.1.2 Test Limit

FCC Part 15 Subpart C(15.247)/RSS-210		
Test Item	Limit	Frequency Range(MHz)
Bandwidth	≥ 500 KHz (6dB bandwidth)	2400~2483.5

6.2 Test Setup

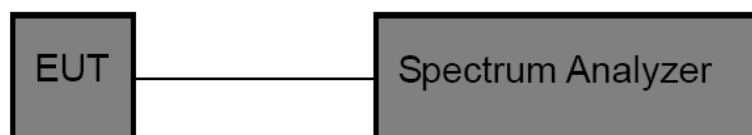

6.3 Test Procedure

- (1) The EUT was directly connected to the spectrum analyzer and antenna output port as show in the block diagram above.
- (2) The bandwidth is measured at an amplitude level reduced 6dB from the reference level. The reference level is the level of the highest amplitude signal observed from the transmitter at the fundamental frequency. Once the reference level is established, the equipment is conditioned with typical modulating signal to produce the worst –case (i.e the widest) bandwidth.
- (3) Measure the channel separation the spectrum analyzer was set to Resolution Bandwidth:100 kHz, and Video Bandwidth:300 kHz, Detector: Peak, Sweep Time set auto.

6.4 EUT Operating Condition

The EUT was set to continuously transmitting in each mode and low, middle and high channel for the test.

6.5 Test Equipment

Equipment	Manufacturer	Model No.	Serial No.	Last Cal.	Cal. Due Date
Spectrum Analyzer	Agilent	E4407B	MY45106456	Mar. 20, 2014	Mar. 19, 2015

6.6 Test Data

EUT:	Gurubook 5/MID	Model Name :	GURUBOOK5
Temperature:	25 °C	Relative Humidity:	55%
Test Voltage:	AC 120V/60 Hz		
Test Mode:	TX 802.11B Mode		
Channel frequency (MHz)	6dB Bandwidth (MHz)	99% Bandwidth (MHz)	Limit (MHz)
2412	10.101	15.0733	≥0.5
2437	10.103	15.0558	
2462	10.090	15.0720	
802.11B Mode			
2412 MHz			
<p>Agilent 14:48:47 Aug 28, 2014</p> <p>Ref 15 dBm Atten 25 dB</p> <p>#Peak Log 10 dB/</p> <p>Center 2.41200000 GHz</p> <p>Center 2.412 GHz Span 20 MHz #Res BW 100 kHz #VBW 100 kHz Sweep 4 ms (401 pts)</p> <p>Occupied Bandwidth 15.0733 MHz Occ BW % Pwr 99.00 % x dB -6.00 dB</p> <p>Transmit Freq Error 15.235 kHz x dB Bandwidth 10.101 MHz</p>			

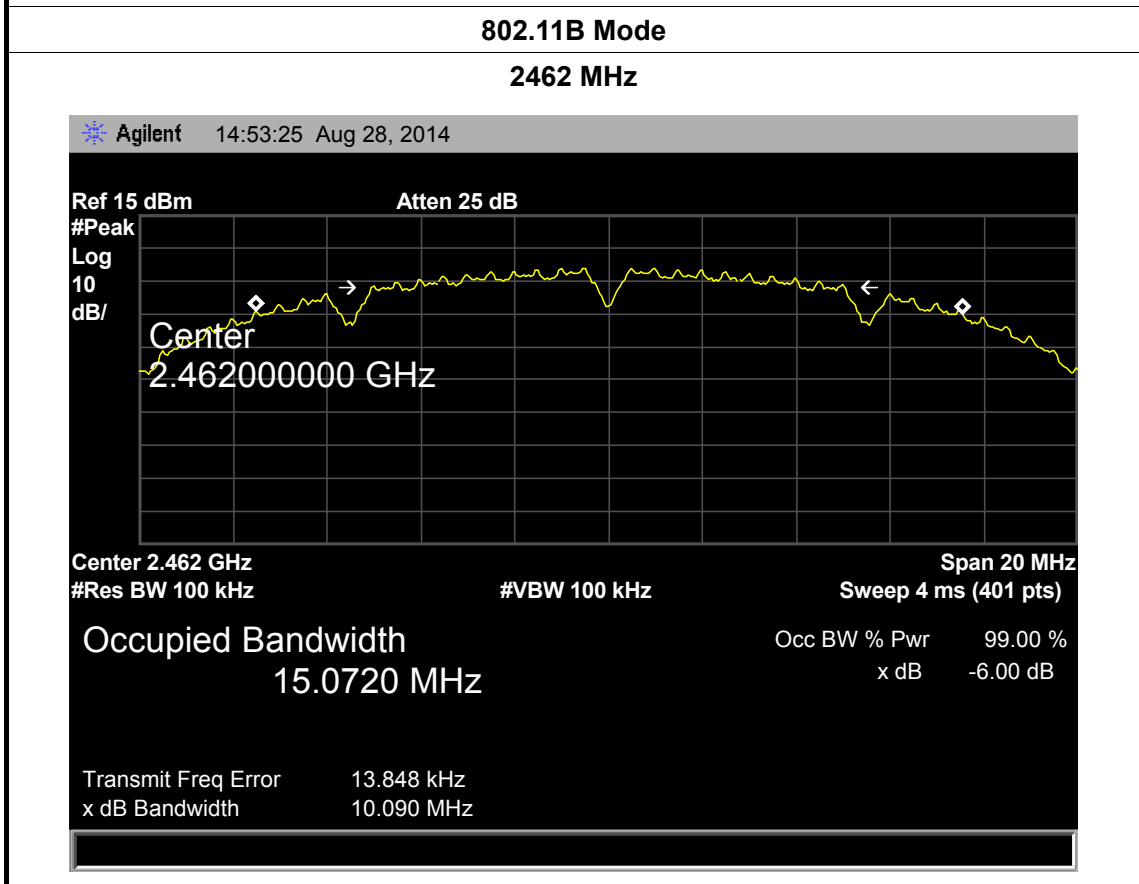
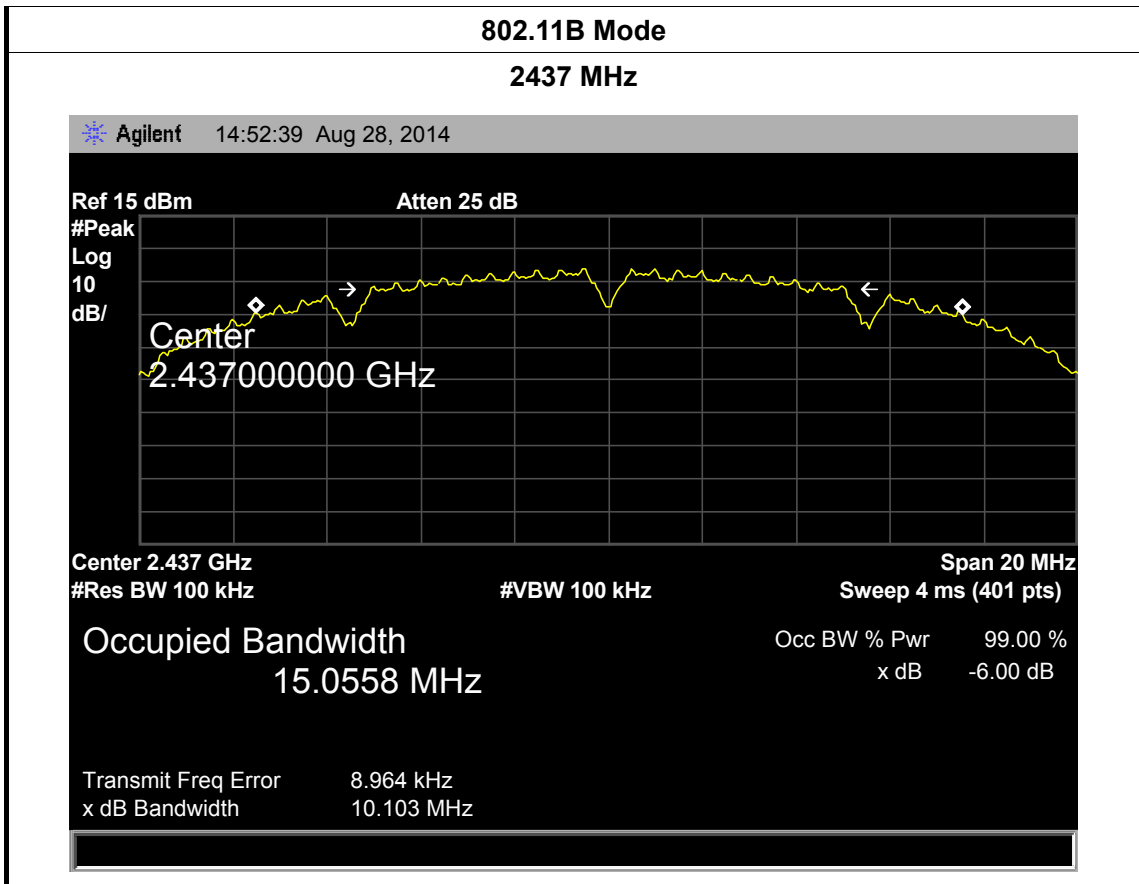

EUT:	Gurubook 5/MID	Model Name :	GURUBOOK5
Temperature:	25 °C	Relative Humidity:	55%
Test Voltage:	AC 120V/60 Hz		
Test Mode:	TX 802.11G Mode		
Channel frequency (MHz)	6dB Bandwidth (MHz)	99% Bandwidth (MHz)	Limit (MHz)
2412	16.621	16.4775	≥0.5
2437	16.581	16.4640	
2462	16.622	16.4873	
802.11G Mode			
2412 MHz			
<p>Agilent 15:21:49 Aug 28, 2014</p> <p>Ref 15 dBm Atten 25 dB</p> <p>#Peak Log 10 dB/</p> <p>Center 2.41200000 GHz</p> <p>Center 2.412 GHz Res BW 100 kHz #VBW 100 kHz Span 20 MHz Sweep 4 ms (401 pts)</p> <p>Occupied Bandwidth 16.4775 MHz Occ BW % Pwr 99.00 % x dB -6.00 dB</p> <p>Transmit Freq Error -15.130 kHz x dB Bandwidth 16.621 MHz</p>			

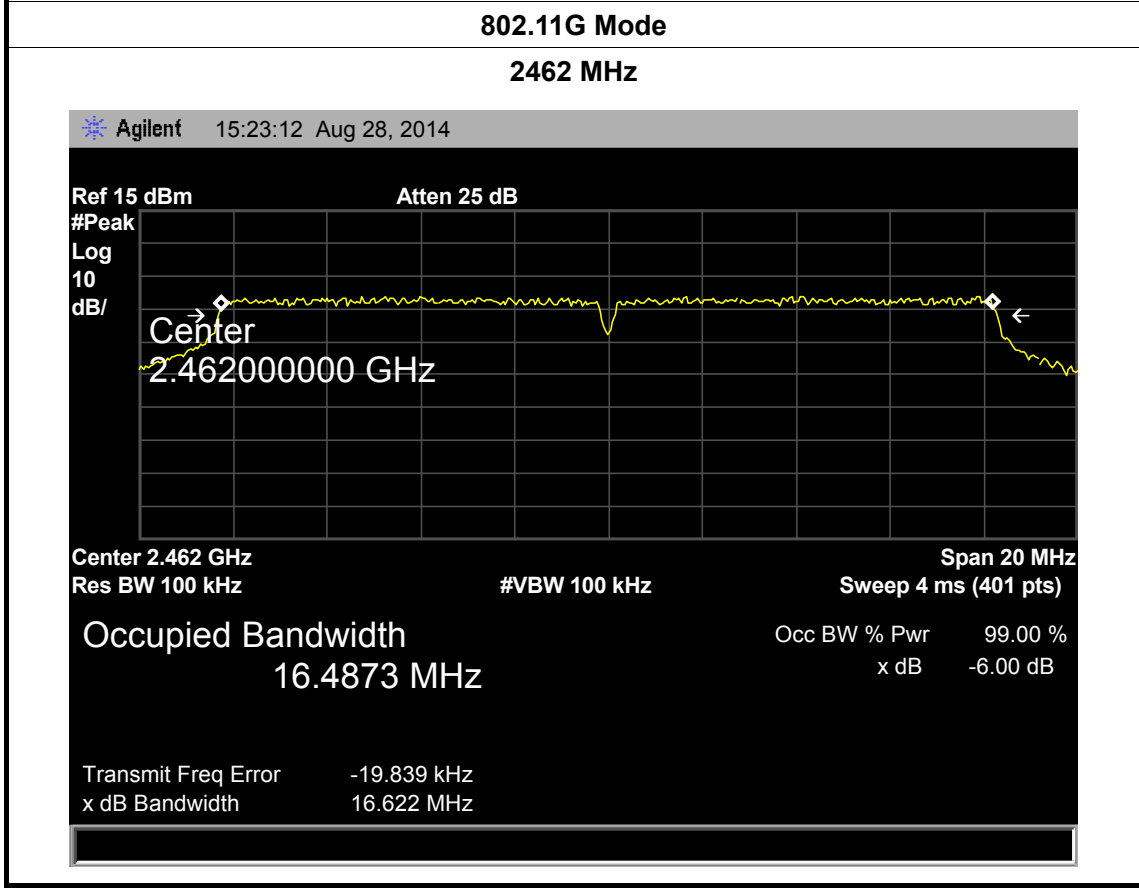
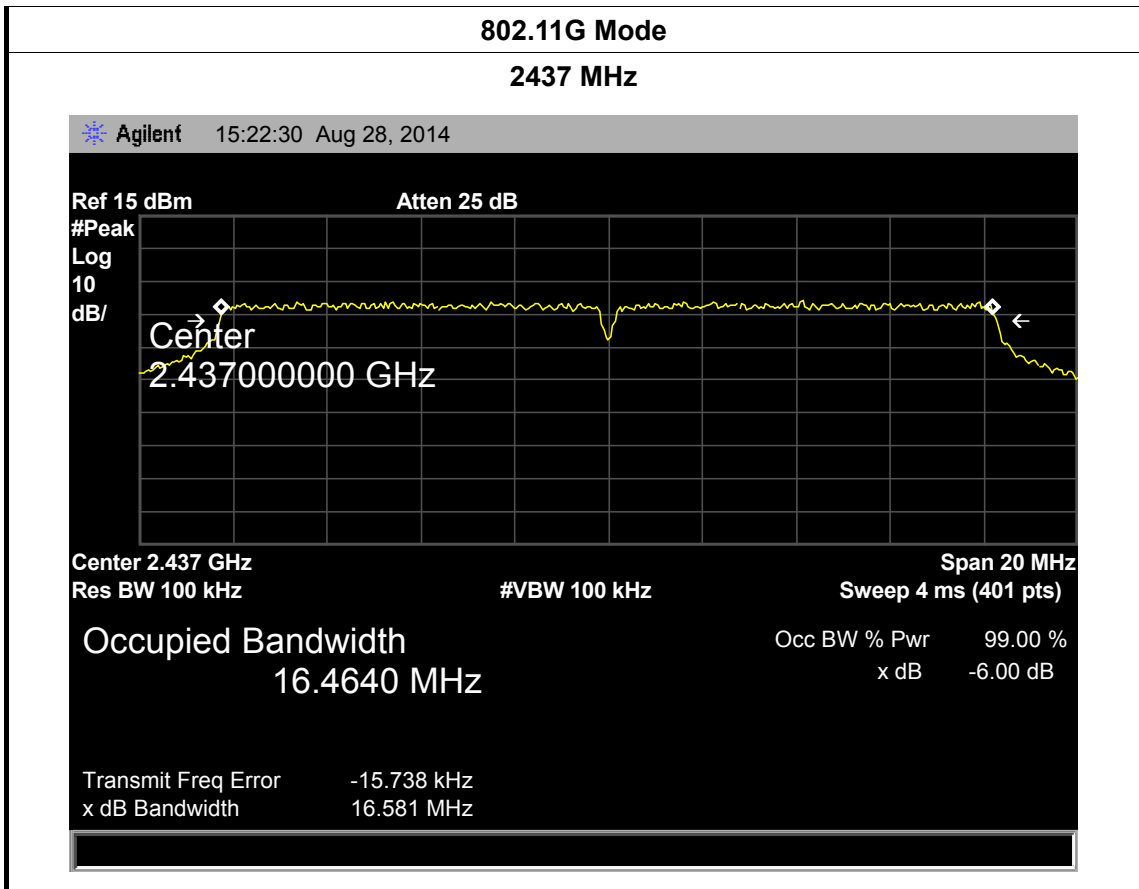

EUT:	Gurubook 5/MID	Model Name :	GURUBOOK5
Temperature:	25 °C	Relative Humidity:	55%
Test Voltage:	AC 120V/60 Hz		
Test Mode:	TX 802.11N(HT20) Mode		
Channel frequency (MHz)	6dB Bandwidth (MHz)	99% Bandwidth (MHz)	Limit (MHz)
2412	17.853	17.6951	>=0.5
2437	17.856	17.7063	
2462	17.854	17.6952	

802.11N(HT20) Mode

2412 MHz

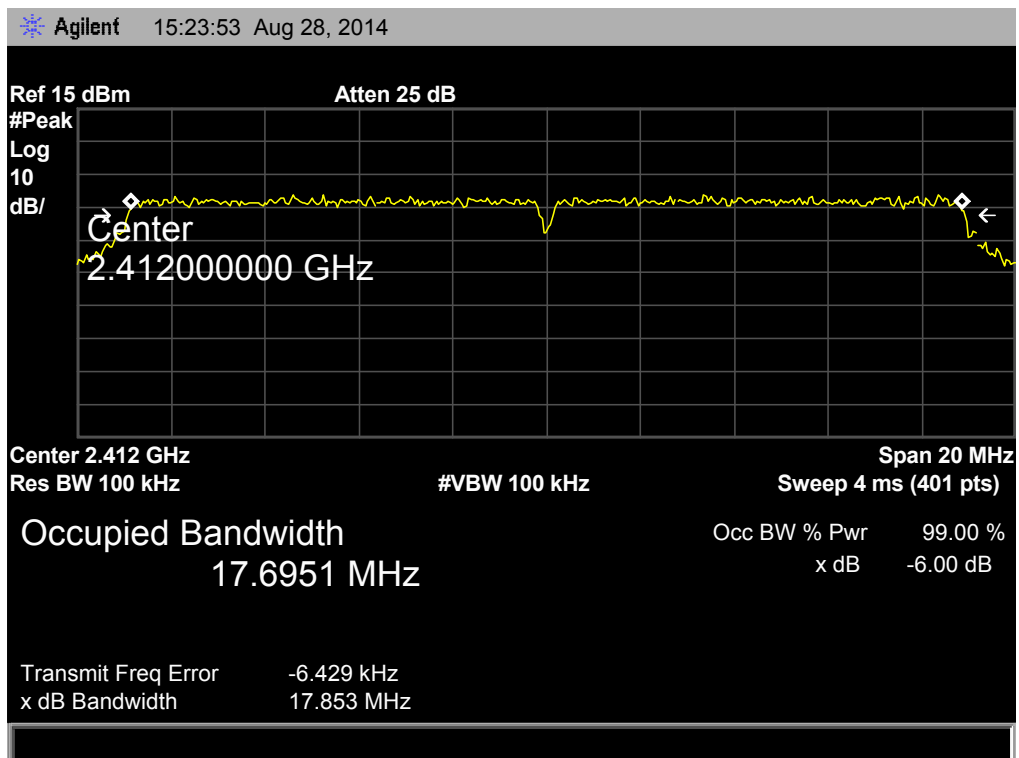

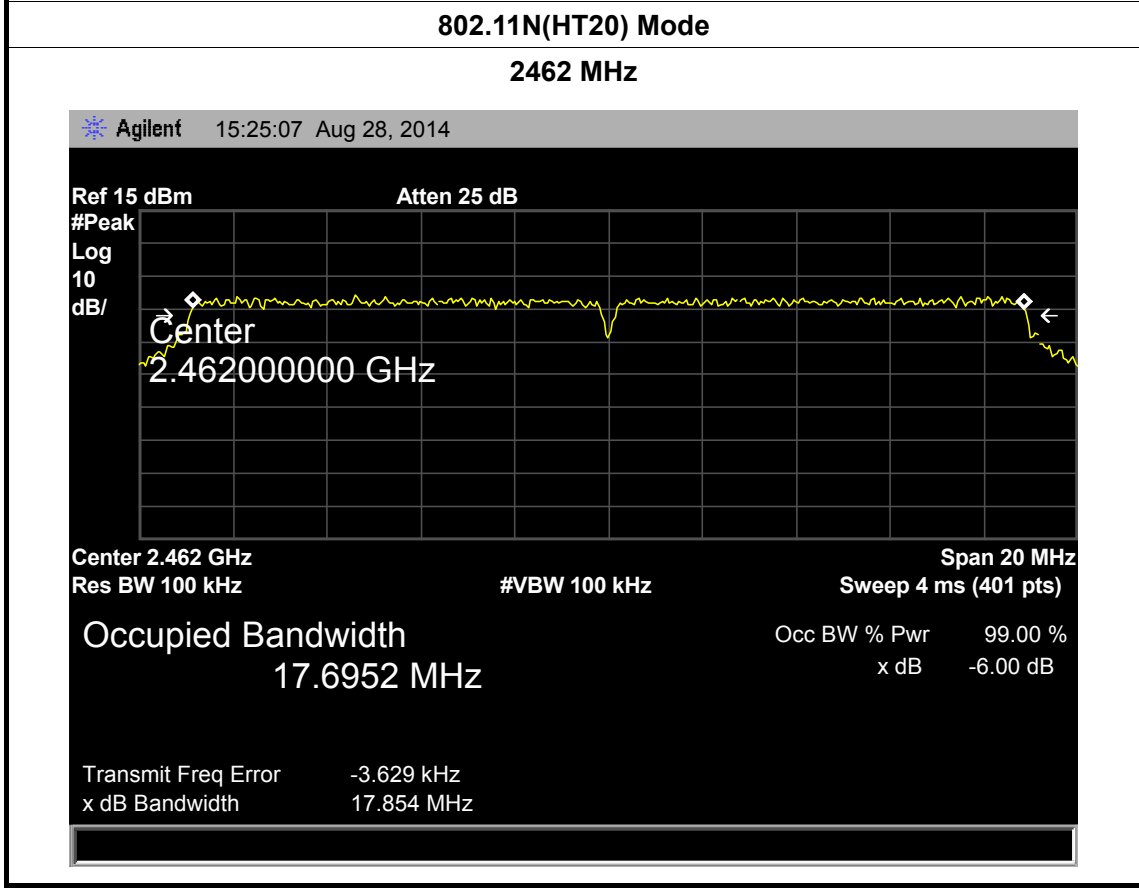
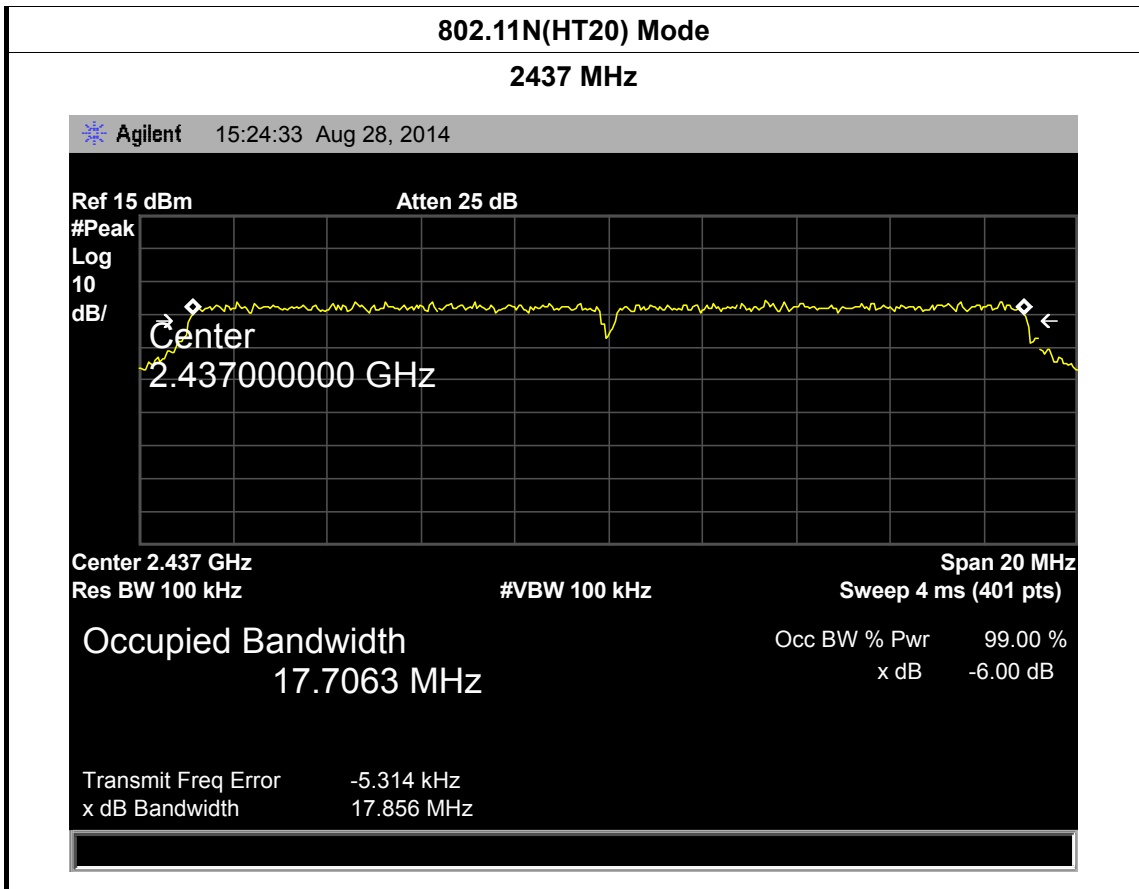

EUT:	Gurubook 5/MID	Model Name :	GURUBOOK5
Temperature:	25 °C	Relative Humidity:	55%
Test Voltage:	AC 120V/60 Hz		
Test Mode:	TX 802.11N(HT40) Mode		
Channel frequency (MHz)	6dB Bandwidth (MHz)	99% Bandwidth (MHz)	Limit (MHz)
2422	36.497	36.0017	>=0.5
2437	36.506	36.0008	
2452	36.513	36.0079	

802.11N(HT40) Mode

2422 MHz

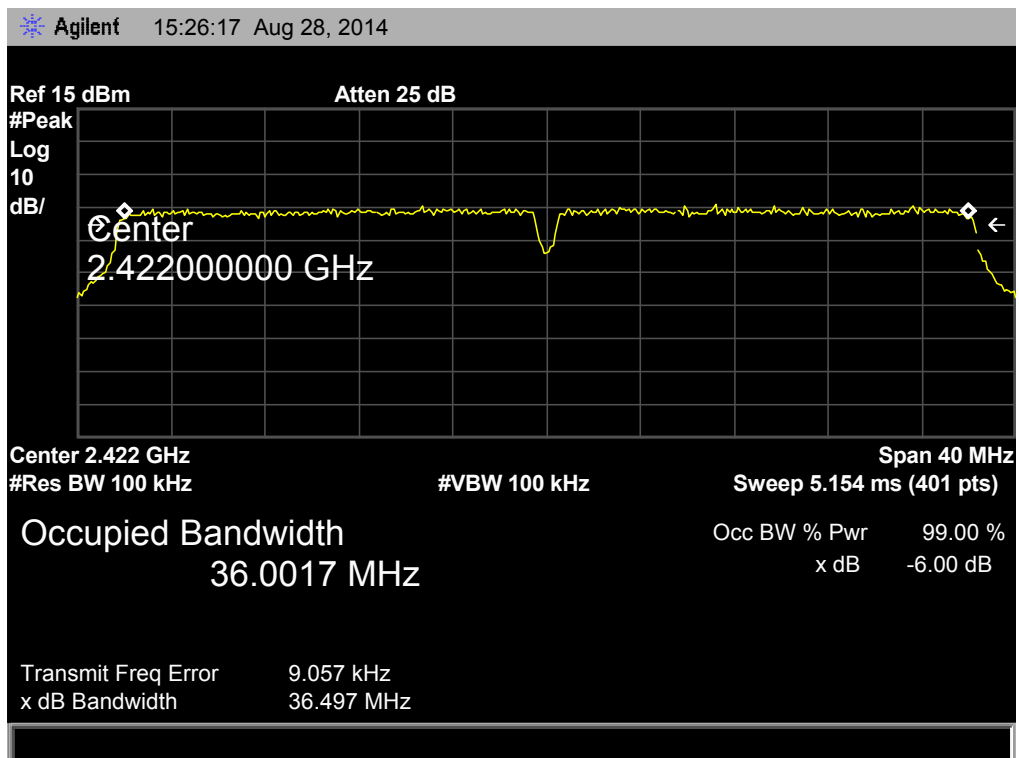

802.11N(HT40) Mode

2437 MHz

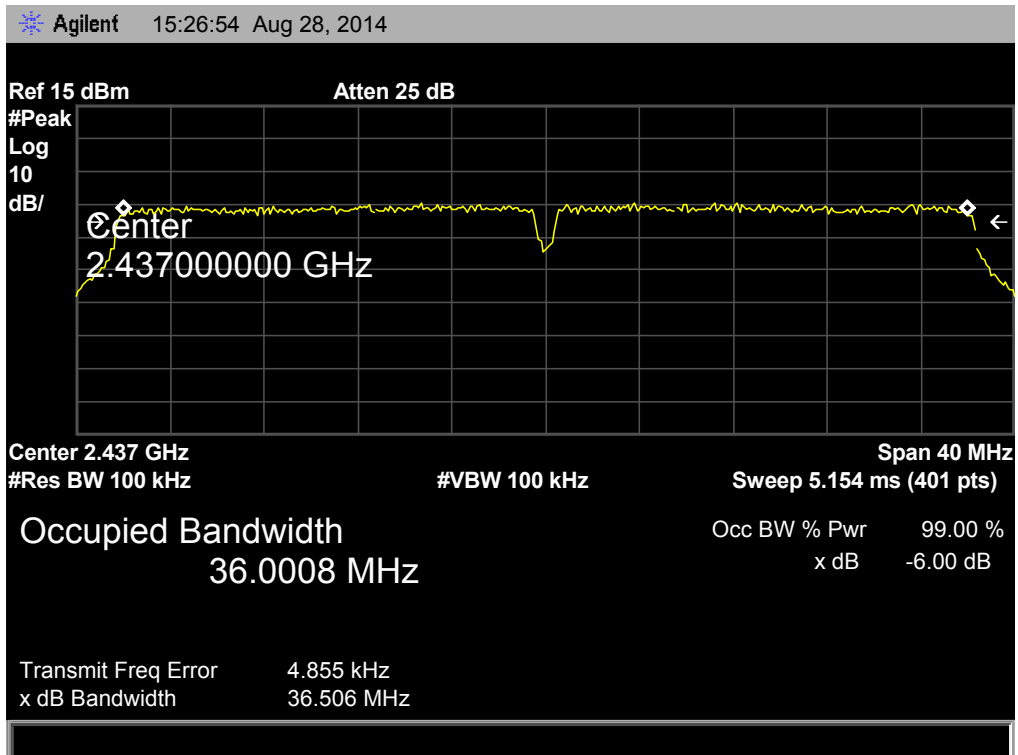

802.11N(HT40) Mode

2452 MHz

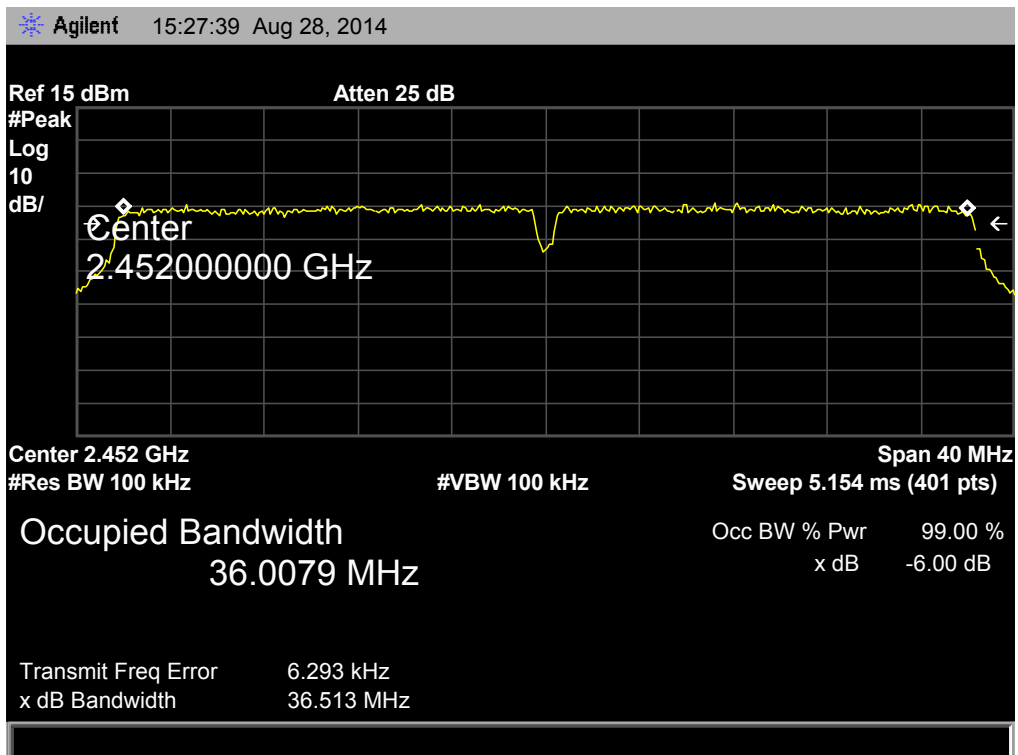

7. Peak Output Power Test

7.1 Test Standard and Limit

7.1.1 Test Standard

FCC Part 15.247 (b)

7.1.2 Test Limit

FCC Part 15 Subpart C(15.247)/RSS-210		
Test Item	Limit	Frequency Range(MHz)
Peak Output Power	1 Watt or 30 dBm	2400~2483.5

7.2 Test Setup

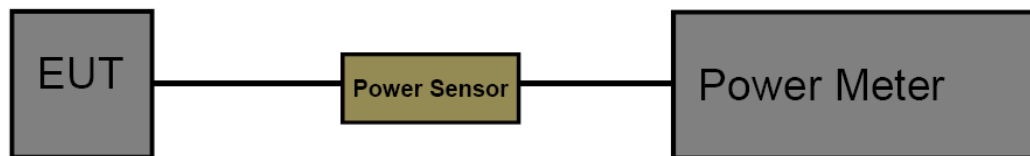

7.3 Test Procedure

The measurement is according to section 9.1.2 of KDB 558074 D01 DTS Meas Guidance v03r02.

The EUT was connected to RF power meter via a broadband power sensor as show the block above. The power sensor video bandwidth is greater than or equal to the DTS bandwidth of the equipment.

7.4 EUT Operating Condition

The EUT was set to continuously transmitting in the max power during the test.

7.5 Test Equipment

Equipment	Manufacturer	Model No.	Serial No.	Last Cal.	Cal. Due Date
Power Meter	Anritsu	ML2495A	25406005	Dec. 20, 2013	Dec. 19, 2014
Power Sensor	Anritsu	ML2411B	25406005	Dec. 20, 2013	Dec. 19, 2014

7.6 Test Data

EUT:	Gurubook 5/MID	Model Name :	GURUBOOK5
Temperature:	25 °C	Relative Humidity:	55%
Test Voltage:	AC 120V/60 HZ		
Mode	Channel frequency (MHz)	Test Result (dBm)	Limit (dBm)
802.11b	2412	9.75	30
	2437	9.79	
	2462	9.80	
802.11g	2412	9.42	
	2437	9.46	
	2462	9.38	
802.11n (HT20)	2412	9.36	
	2437	9.32	
	2462	9.27	
802.11n (HT40)	2422	8.06	
	2437	8.17	
	2452	8.30	

8. Power Spectral Density Test

8.1 Test Standard and Limit

8.1.1 Test Standard

FCC Part 15.247 (e)

8.1.2 Test Limit

FCC Part 15 Subpart C(15.247)		
Test Item	Limit	Frequency Range(MHz)
Power Spectral Density	8dBm(in any 3 kHz)	2400~2483.5

8.2 Test Setup

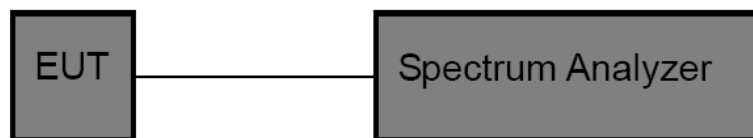

8.3 Test Procedure

The EUT was directly connected to the Spectrum Analyzer and antenna output port as show in the block diagram above. The measurement according to section 10.2 of KDB 558074 D01 DTS Meas Guidance v03r02.

- (1) The EUT was directly connected to the spectrum analyzer and antenna output port as show in the block diagram above.
- (2) Set analyser center frequency to DTS channel center frequency.
- (3) Set the span to 1.5 times the DTS bandwidth.
- (4) Set the RBW to: 3 kHz
- (5) Set the VBW to: 10 kHz
- (6) Detector: peak
- (7) Sweep time: auto
- (8) Allow trace to fully stabilize. Then use the peak marker function to determine the maximum amplitude level.

8.4 EUT Operating Condition

The EUT was set to continuously transmitting in each mode and low, middle and high channel for the test.

8.5 Test Equipment

Equipment	Manufacturer	Model No.	Serial No.	Last Cal.	Cal. Due Date
Spectrum Analyzer	Agilent	E4407B	MY45106456	Mar. 20, 2014	Mar. 19, 2015

8.6 Test Data

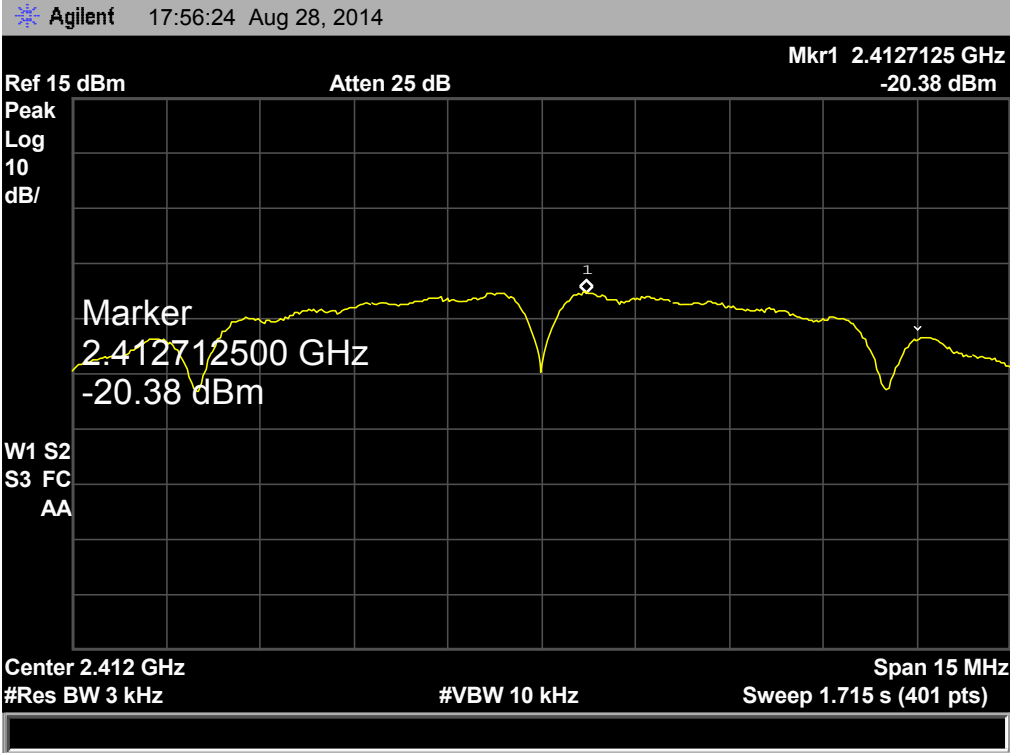
EUT:	Gurubook 5/MID	Model Name :	GURUBOOK5
Temperature:	25 °C	Relative Humidity:	55%
Test Voltage:	AC 120V/60 HZ		
Test Mode:	TX 802.11B Mode		
Channel Frequency (MHz)	Power Density (3 kHz/dBm)	Limit (dBm)	
2412	-20.38	8	
2437	-20.28		
2462	-20.27		
802.11B Mode			
2412 MHz			
 <p>Agilent 17:56:24 Aug 28, 2014</p> <p>Ref 15 dBm Atten 25 dB Mkr1 2.4127125 GHz -20.38 dBm</p> <p>Peak Log 10 dB/</p> <p>Marker 2.412712500 GHz -20.38 dBm</p> <p>W1 S2 S3 FC AA</p> <p>Center 2.412 GHz Span 15 MHz #Res BW 3 kHz #VBW 10 kHz Sweep 1.715 s (401 pts)</p>			

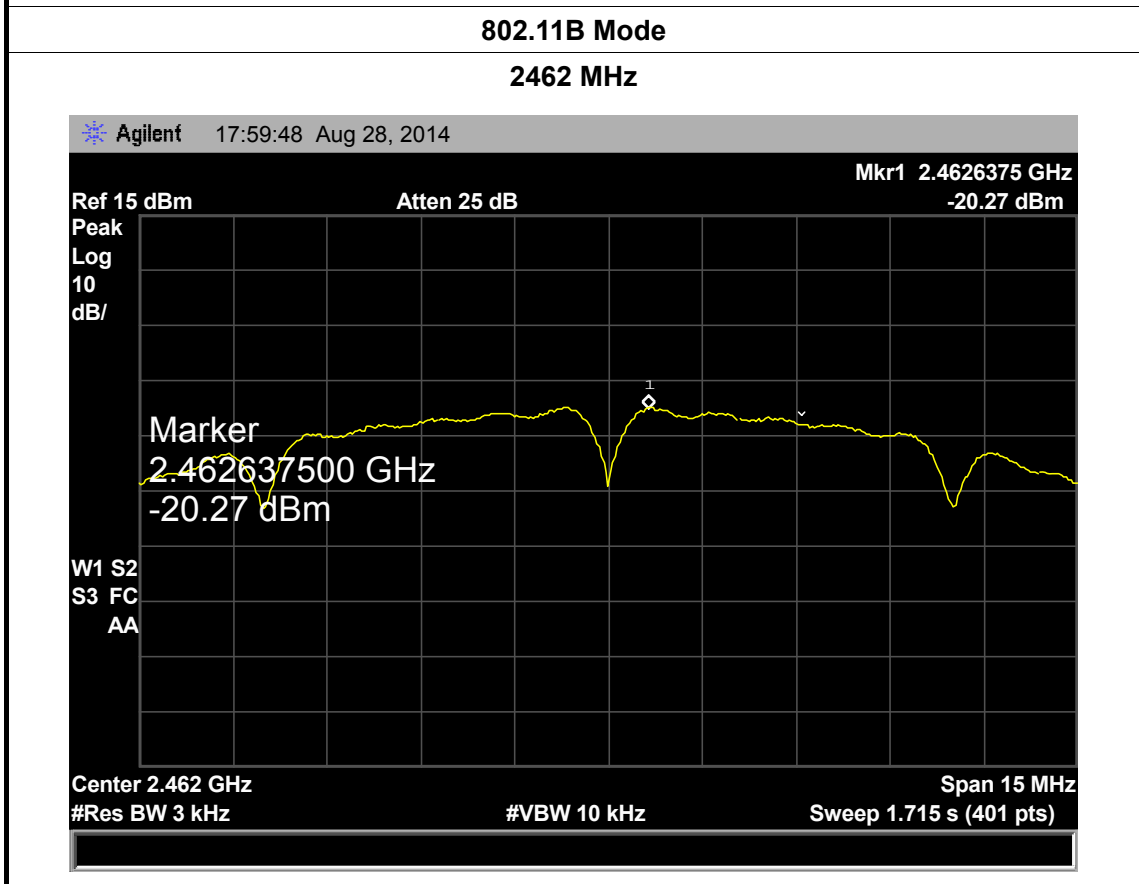
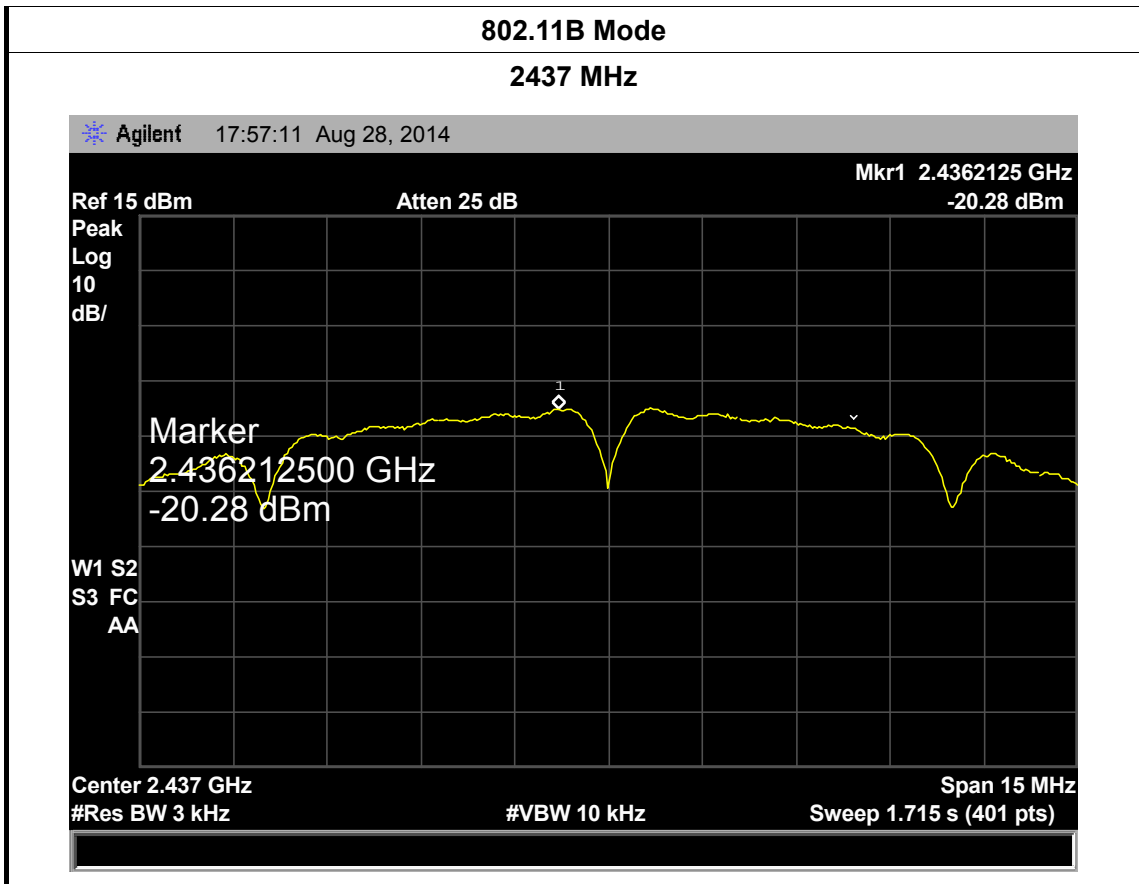

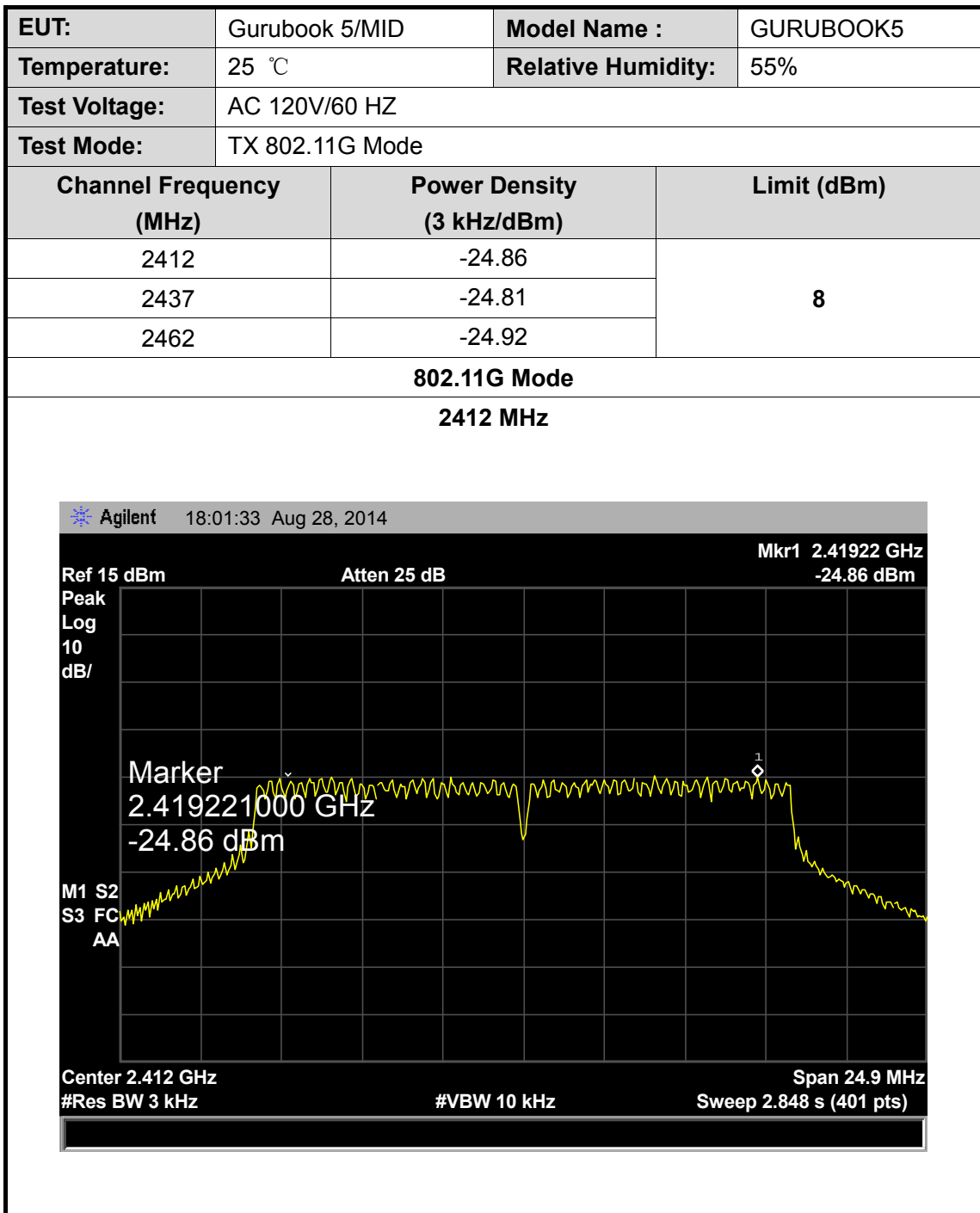

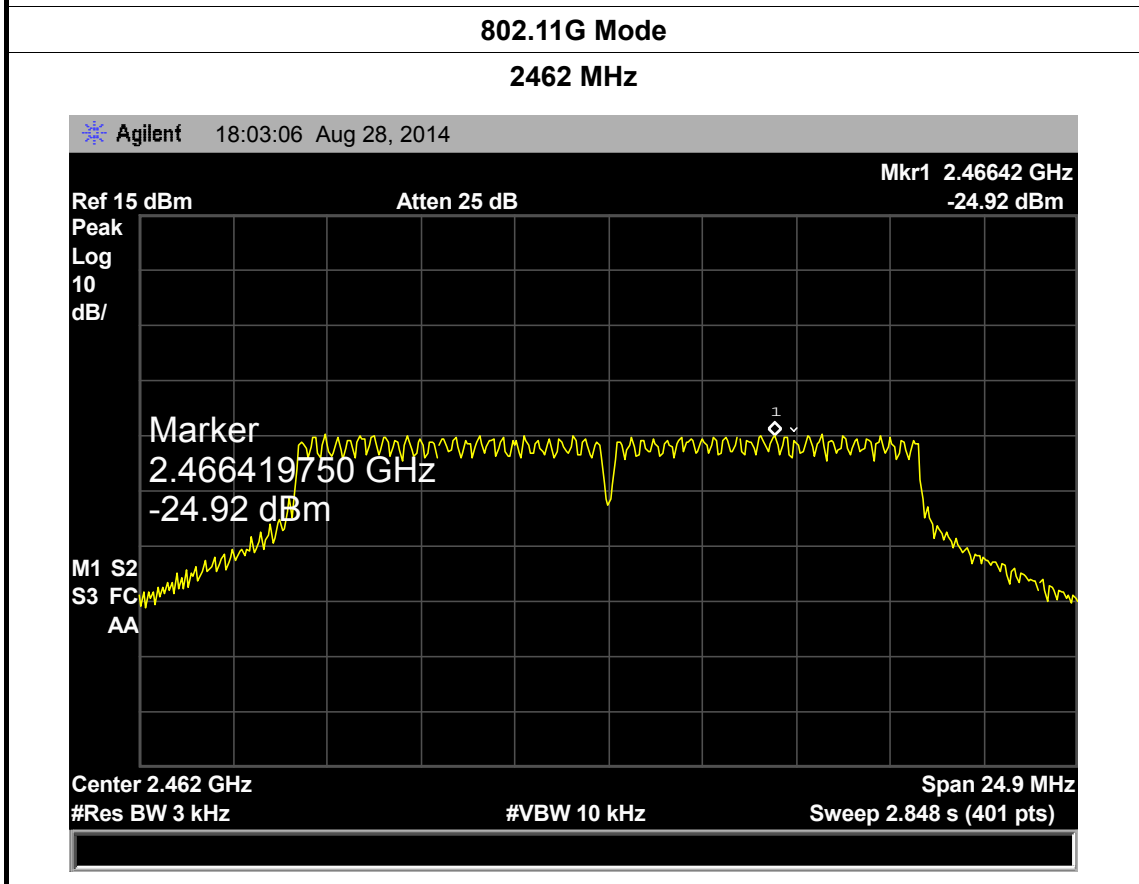
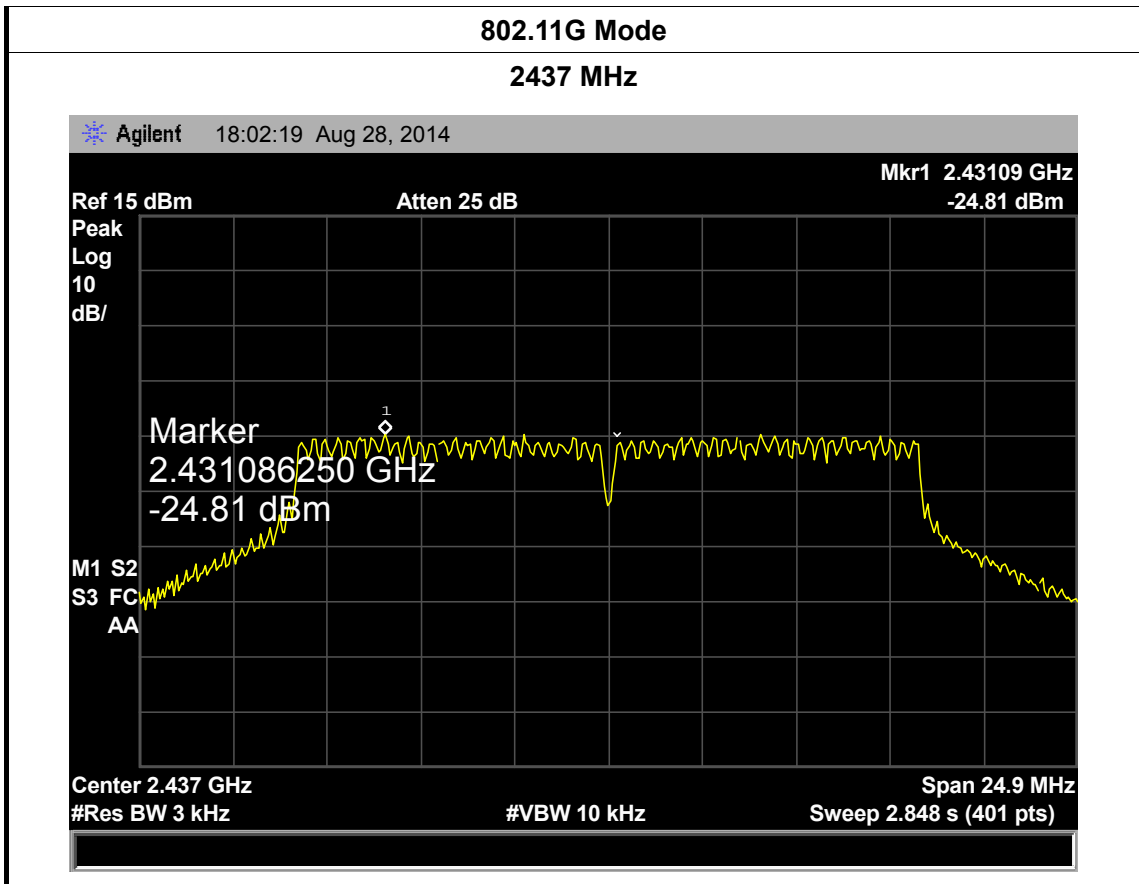

EUT:	Gurubook 5/MID	Model Name :	GURUBOOK5
Temperature:	25 °C	Relative Humidity:	55%
Test Voltage:	AC 120V/60 HZ		
Test Mode:	TX 802.11N(HT20) Mode		
Channel Frequency (MHz)	Power Density (3 kHz/dBm)	Limit (dBm)	
2412	-24.33	8	
2437	-24.35		
2462	-24.10		
802.11N(HT20) Mode			
2412 MHz			
<p>Agilent 18:12:04 Aug 28, 2014</p> <p>Ref 15 dBm Atten 25 dB Mkr1 2.41851 GHz -24.33 dBm</p> <p>Peak Log 10 dB/</p> <p>Marker 2.41851125 GHz -24.33 dBm</p> <p>M1 S2 S3 FC AA</p> <p>Center 2.412 GHz Span 26.85 MHz #Res BW 3 kHz #VBW 10 kHz Sweep 3.071 s (401 pts)</p>			

802.11N(HT20) Mode

2437 MHz

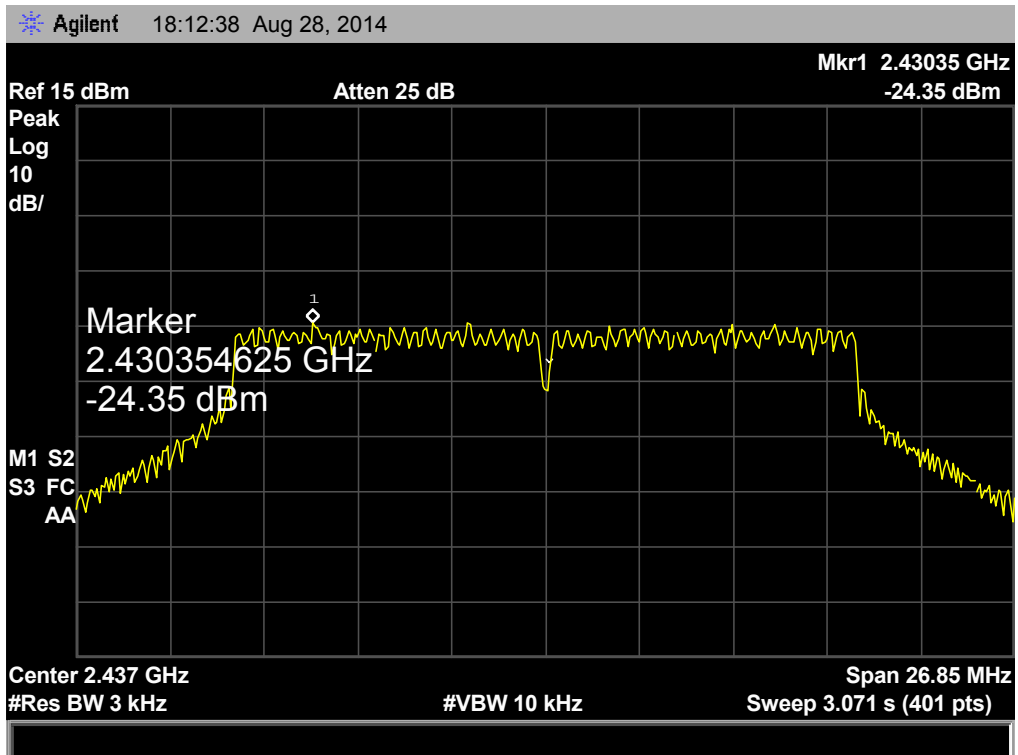

802.11N(HT20) Mode

2462 MHz

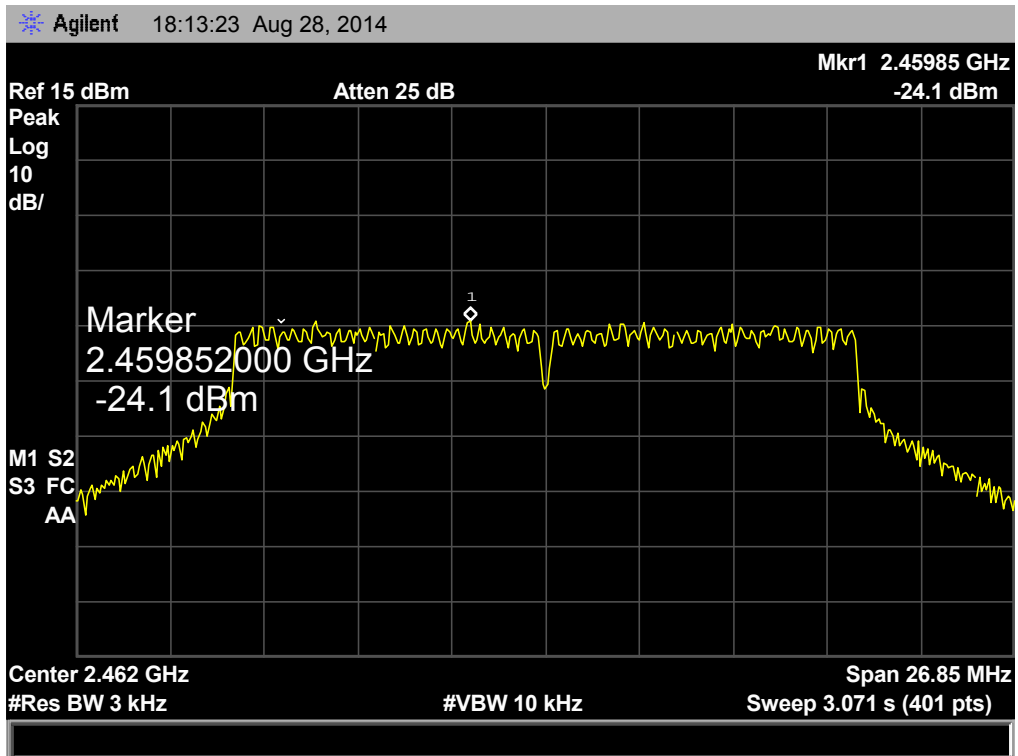

EUT:	Gurubook 5/MID	Model Name :	GURUBOOK5
Temperature:	25 °C	Relative Humidity:	55%
Test Voltage:	AC 120V/60 HZ		
Test Mode:	TX 802.11N(HT40) Mode		
Channel Frequency (MHz)	Power Density (3 kHz/dBm)	Limit (dBm)	
2422	-28.56	8	
2437	-27.58		
2452	-26.75		

802.11N(HT40) Mode

2422 MHz

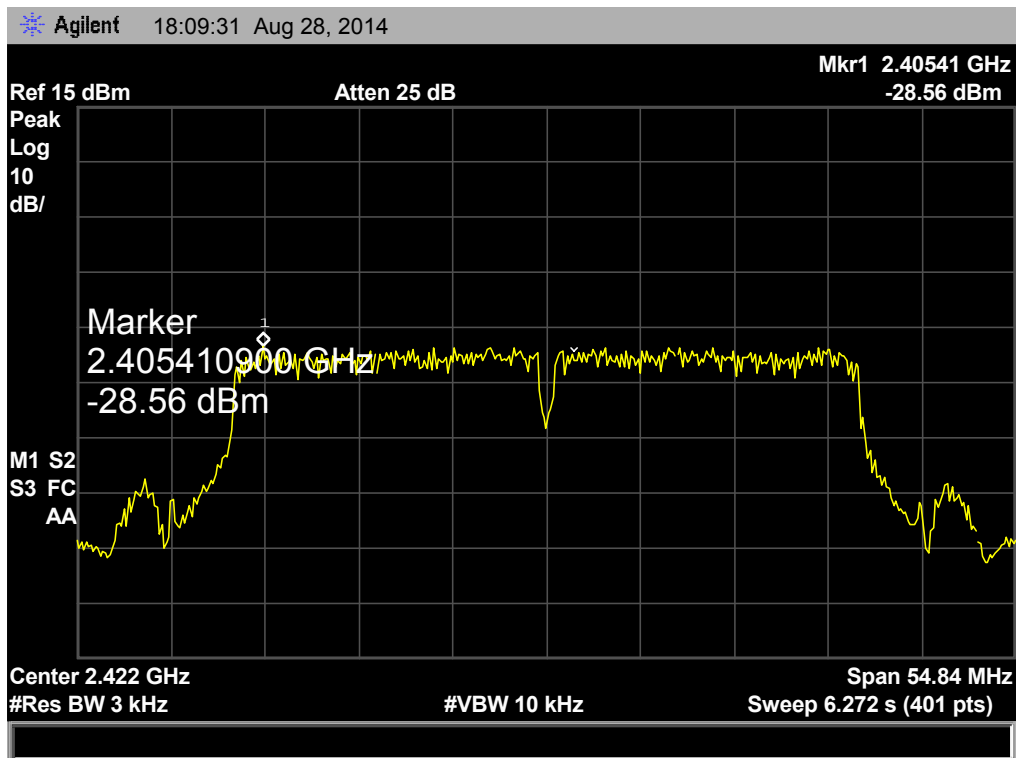

802.11N(HT40) Mode

2437 MHz

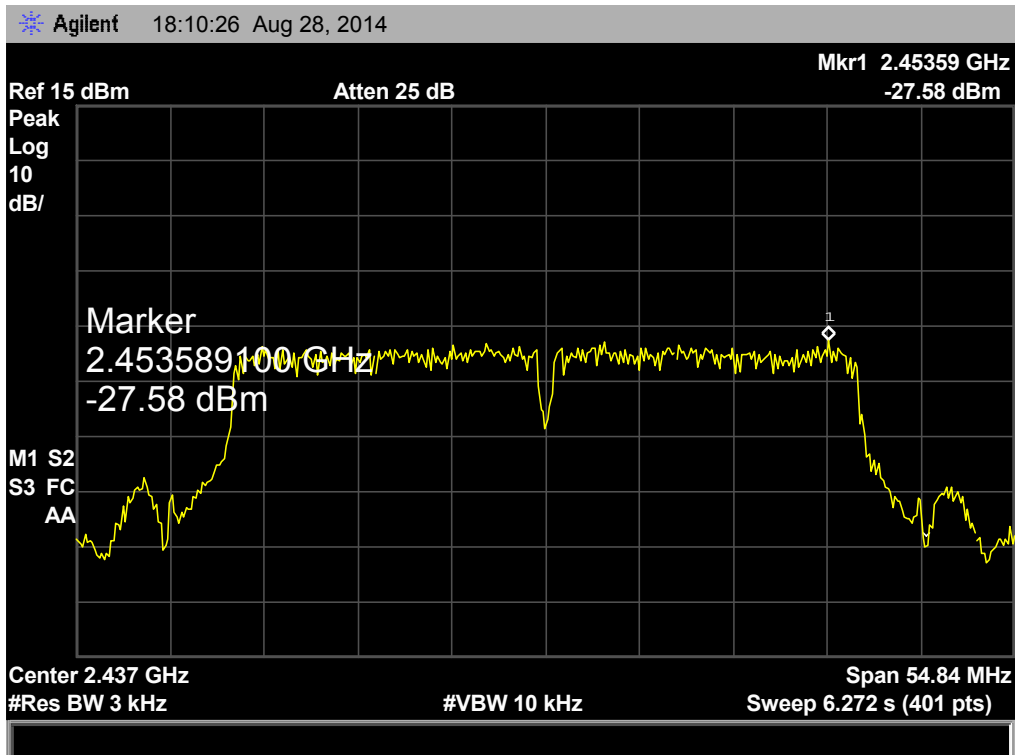

802.11N(HT40) Mode

2452 MHz

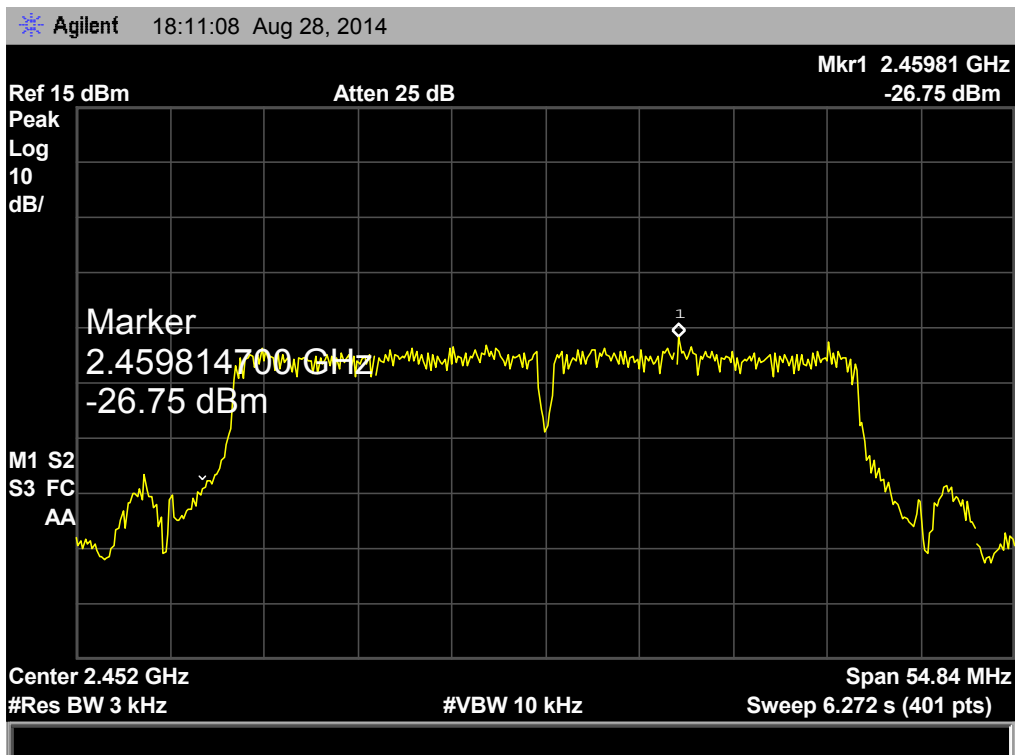

9. Antenna Requirement

9.1 Standard Requirement

9.1.1 Standard

FCC Part 15.203

9.1.2 Requirement

An intentional radiator shall be designed to ensure that no antenna other than that furnished by the responsible party shall be used with the device. The use of a permanently attached antenna or of an antenna that uses a unique coupling to the intentional radiator shall be considered sufficient to comply with the provisions of this Section. The manufacturer may design the unit so that a broken antenna can be replaced by the user, but the use of a standard antenna jack or electrical connector is prohibited.

9.2 Antenna Connected Construction

The directional gains of the antenna used for transmitting is 0dBi, and the antenna de-signed with permanent attachment and no consideration of replacement. Please see the EUT photo for details.

9.3 Result

The EUT antenna is a FPC Antenna. It complies with the standard requirement.