



849 NW STATE ROAD 45
NEWBERRY, FL 32669 USA
PH: 888.472.2424 OR 352.472.5500
FAX: 352.472.2030
EMAIL: INFO@TIMCOENGR.COM
[HTTP://WWW.TIMCOENGR.COM](http://WWW.TIMCOENGR.COM)

FCC PART 90 TEST REPORT

APPLICANT	N. WILLIAM KOSTIS D/B/A SOUTHERN MAINE COMMUNICATIONS
	AIRPORT INDUSTRIAL PARK 9 KOSTIS LANE
	SANDFORD ME 04073 USA
FCC ID	2ABEE125MIIU
PRODUCT DESCRIPTION	UHF MASTR II BASE STATION
DATE SAMPLE RECEIVED	2/11/2014
DATE TESTED	2/20/2014
REPORT ISSUE DATE	4/15/2014
TESTED BY	NAM NGUYEN
APPROVED BY	NAM NGUYEN
TIMCO REPORT NO.	209AUT14TestReport.docx
TEST RESULTS	<input checked="" type="checkbox"/> PASS <input type="checkbox"/> FAIL

**THE ATTACHED REPORT SHALL NOT BE REPRODUCED EXCEPT IN FULL
WITHOUT THE WRITTEN APPROVAL OF TIMCO ENGINEERING, INC.**



TABLE OF CONTENTS

GENERAL REMARKS..... 3

GENERAL INFORMATION..... 4

EQUIPMENT LIST 5

EMI TEST RECEIVER FIRMWARE VERSION USED 5

TEST PROCEDURE..... 6

RF POWER OUTPUT 7

MODULATION CHARACTERISTICS 8

VOICE MODULATED COMMUNICATION EQUIPMENT 9

OTHER MODULATION CHARACTERISTICS..... 11

OCCUPIED BANDWIDTH PLOTS..... 14

SPURIOUS EMISSIONS AT ANTENNA TERMINALS (CONDUCTED) 17

FIELD STRENGTH OF SPURIOUS EMISSIONS 20

FREQUENCY STABILITY..... 22

TRANSIENT FREQUENCY BEHAVIOR 23

GENERAL REMARKS

The attached report shall not be reproduced except in full without the written permission of Timco Engineering Inc.

Summary

The device under test does:

- fulfill the general approval requirements as identified in this test report
- not fulfill the general approval requirements as identified in this test report

Attestations

This equipment has been tested in accordance with the standards identified in this test report. To the best of my knowledge and belief, these tests were performed using the measurement procedures described in this report.

All instrumentation and accessories used to test products for compliance to the indicated standards are calibrated regularly in accordance with ISO 17025 requirements.

I attest that the necessary measurements were made, under my supervision, at:

Timco Engineering Inc.
849 NW State Road 45
Newberry, FL 32669



Authorized Signatory Name:

Nam Nguyen
Engineering Project Manager

Date: 4/15/2014



GENERAL INFORMATION

DUT Specification

DUT Description	UHF MASTR II BASE STATION
FCC ID	2ABEE125MIIU
Operating Frequency	450 – 470 MHz
No. of Channels	36
Type of Emission	10K0F3E
Modulation	FM
DUT Power Source	<input type="checkbox"/> 110–120Vac/50– 60Hz
	<input checked="" type="checkbox"/> DC Power 12V
	<input type="checkbox"/> Battery Operated Exclusively
Test Item	<input type="checkbox"/> Prototype
	<input type="checkbox"/> Pre-Production
	<input checked="" type="checkbox"/> Production
Type of Equipment	<input checked="" type="checkbox"/> Fixed
	<input type="checkbox"/> Mobile
	<input type="checkbox"/> Portable
Test Conditions	The temperature was 26°C with a relative humidity of 50%.
Modification to the DUT	None
Test Exercise	The DUT was placed in continuous transmit mode.
Applicable Standards	ANSI/TIA 603-C:2004, FCC CFR 47 Part 90
Test Facility	Timco Engineering Inc. at 849 NW State Road 45 Newberry, FL 32669 USA.

EQUIPMENT LIST

Device	Manufacturer	Model	Serial Number	Cal/Char Date	Due Date
Antenna: Biconnical	Eaton	94455-1	1096	05/10/13	05/10/15
Antenna: Log-Periodic	Electro-Metrics	LPA-25	1122	05/09/13	05/09/15
Antenna: Double-Ridged Horn/ETS Horn 2	ETS-Lindgren	3117	00041534	10/05/12	10/05/14
Frequency Counter	HP	5385A	2730A03025	08/22/13	08/22/15
Hygro-Thermometer	Extech	445703	0602	06/20/13	06/20/15
Digital Multimeter	Fluke	77	35053830	08/22/13	08/22/15
Notch Filter	Microlab	HA-10N		6/14/12	6/14/14
Tunable Notch Filter		210BFBF		9/15/13	9/15/15
Synthesized Function Generator	Stanford Research Systems	DS345	38435	6/9/13	6/9/15
Modulation Analyzer	Agilent Technologies, Inc.	8901A	3050A05856	9/26/12	9/26/15
Antenna: Double-Ridged Horn	Electro-Metrics	RGA-180	2319	06/19/12	06/19/14
Antenna: Dipole Kit	Electro-Metrics	TDA-30/1-4	152	11/01/13	11/01/15
Temperature Chamber	Tenney Engineering	TTRC	11717-7	07/03/12	07/03/14
3-Meter Semi-Anechoic Chamber	Panashield	N/A	N/A	12/31/13	12/31/15
EMI Test Receiver	Rohde & Schwarz	ESIB40	100274	2/15/13	2/15/15
EMI Test Receiver	Rohde & Schwarz	ESU40	100320	3/21/13	3/21/15
DC Power Supply	Astron	VLS-25M		03/21/13	03/21/15

EMI TEST RECEIVER FIRMWARE VERSION USED

Manufacturer	Model	Receiver Firmware	BIOS Ver
Rohde & Schwarz	ESU40	4.43 SP3	V5.1-24-3
Rohde & Schwarz	ESIB40	4.34.3	3.3

TEST PROCEDURE

Power Line Conducted Interference: The procedure used was ANSI/TIA 603-C:2004, using a 50uH LISN. Both lines were observed with the UUT transmitting. The bandwidth of the spectrum analyzer was 10 kHz with an appropriate sweep speed.

Bandwidth 20 dB: The measurements were made with the spectrum analyzer's resolution bandwidth (RBW) = 1 MHz and the video bandwidth (VBW) = 3 MHz and the span set as shown on plot.

Power Output: The RF power output was measured at the antenna feed point using a peak power meter.

Antenna Conducted Emissions: The RBW = 100 kHz, VBW = 300 kHz and the span set to 10.0 MHz and the spectrum was scanned from 30 MHz to the 10th harmonic of the fundamental. Above 1 GHz the resolution bandwidth was 1 MHz and the VBW = 3 MHz and the span to 50 MHz.

Radiation Interference: The test procedure used was ANSI/TIA 603-C:2004, using an Agilent spectrum receiver with pre-selector. The bandwidth (RBW) of the spectrum ANSI/TIA 603-C:2004, receiver was 100 kHz up to 1 GHz and 1 MHz above 1 GHz with an appropriate sweep speed. The VBW above 1 GHz was 3 MHz. The analyzer was calibrated in dB above a microvolt at the output of the antenna. The ambient temperature of the UUT was 76°F with a humidity of 55%.

RF POWER OUTPUT

Rule Part No.: Part 2.1046(a), Part 90

Test Requirements:

Method of Measurement: RF power is measured by using a 50-ohm, resistive wattmeter to the RF output connector. With a nominal battery voltage (if battery operated), or a properly adjusted power supply (if not battery operated), and the transmitter properly adjusted the RF output measures:

For the device with a fixed or integral antenna, the RF power is measured as ERP. The substitution method was used. The RF output measures:

Test Setup Diagram:

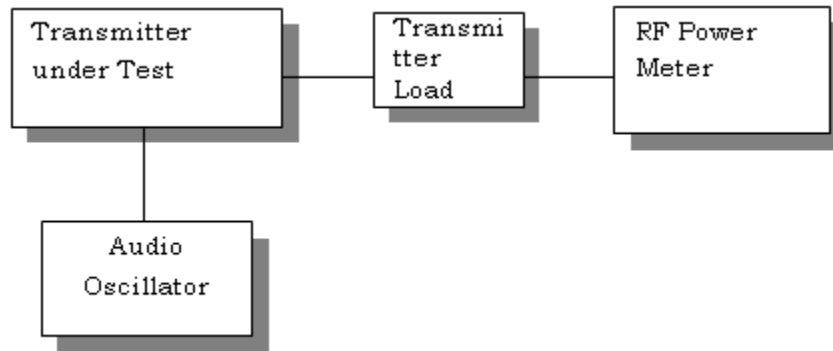

Test Data: The RF power of the EUT can be set at 100W to 30W.

OUTPUT POWER: For the highest and lowest power setting.

Tuned Frequency (MHz)	RF POWER (W)	
	HI	LOW
451.900	99.9	30
461.825	100	30.1
468.270	99.8	29.8

Part 2.1033 (C)(8) DC Input into the final amplifier

FOR HIGH POWER SETTING INPUT POWER: $(13.8V)(27.1A) = 373.98$ Watts

FOR LOW POWER SETTING INPUT POWER: $(13.8V)(15.8A) = 218.04$ Watts

MODULATION CHARACTERISTICS

Rule Part No.: Part 2.1047(a)(b)

Test Requirements:

Method of Measurement:

The audio frequency response was measured in accordance with TIA/EIA Specification 603 with no exception. A curve or equivalent data showing the frequency response of the audio modulating circuit over a range of 100 – 5000Hz shall be submitted. The audio frequency response curve is shown below.

AUDIO FREQUENCY RESPONSE PLOT

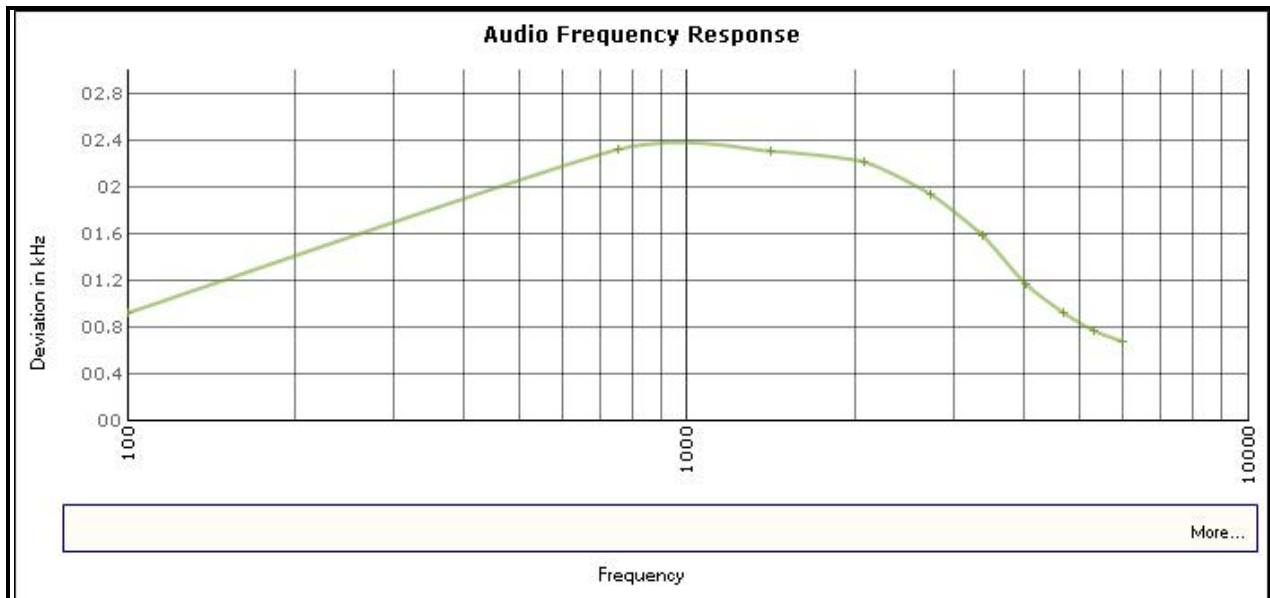

VOICE MODULATED COMMUNICATION EQUIPMENT

Part 2.1047(a): For equipment required to have an audio low-pass filter, a curve showing the frequency response of the filter, or of all the circuitry installed between the modulation limiter and the modulated stage shall be submitted.

AUDIO LOW PASS FILTER PLOT

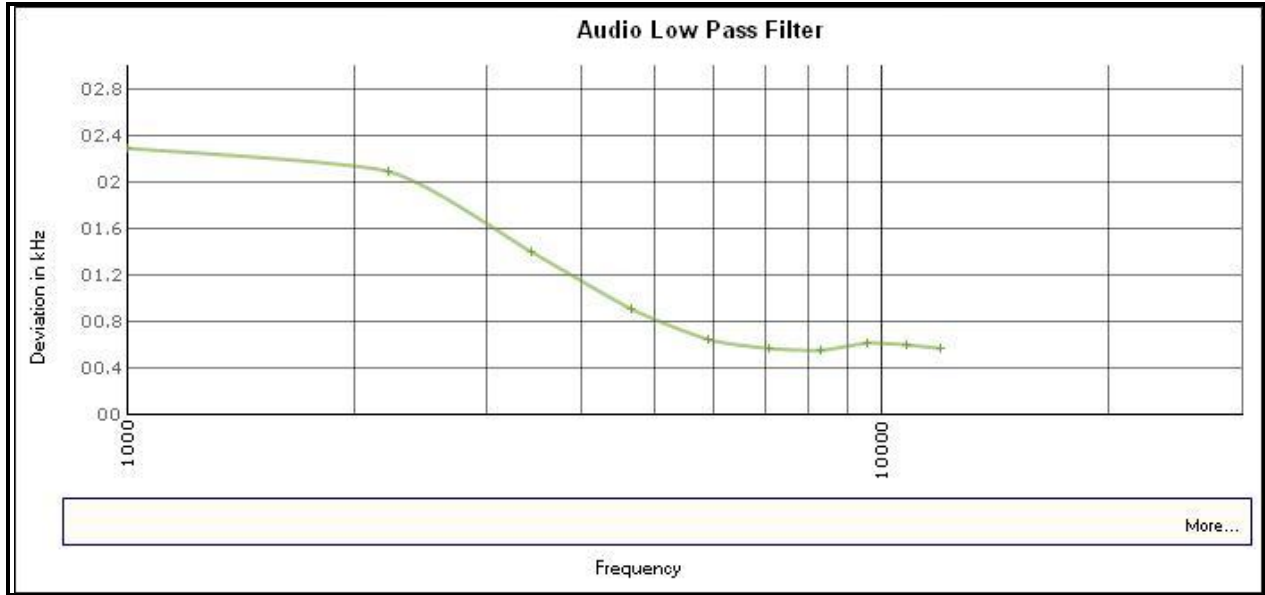

AUDIO INPUT VERSUS MODULATION

Rule Part No.: Part 2.1047(b) & 90

Test Requirements:

Method of Measurement: Modulation cannot exceed 100%, The audio input level needed for a particular percentage of modulation was measured in accordance with ANSI/TIA 603-C: 2004. The audio input curves versus modulation are shown below. Curves are provided for audio input frequencies of 300, 1000, and 3000 Hz.

Test data:

MODULATION LIMITING PLOT

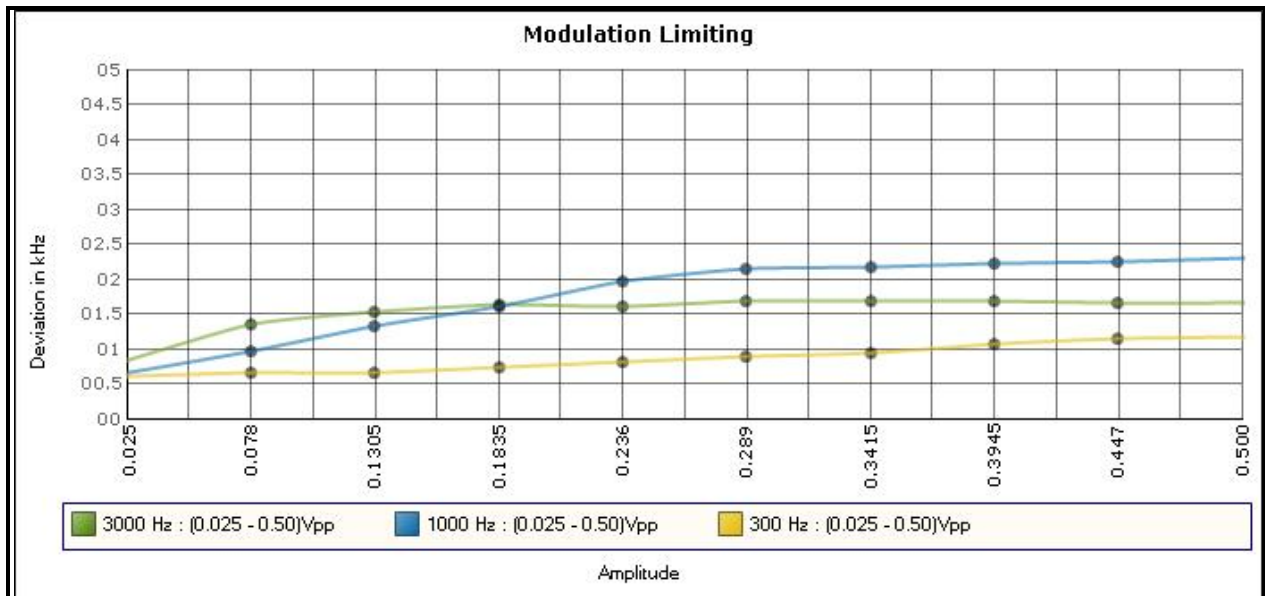



OTHER MODULATION CHARACTERISTICS

Part 2.1033(c) (4) Type of Emission: 10K0F3E

Part 90.209

Part 90.207 $B_n = 2M + 2DK$

$M = 2500$

$D = 2500$

$K=1$

$B_n = 2(2500) + 2(2500) = 10.0k$



OCCUPIED BANDWIDTH

Part 2.1049(c) EMISSION BANDWIDTH:

Part 90.210(b) 25kHz Channel Spacing

Data in the plots show that on any frequency removed from the assigned frequency by more than 50%, but not more than 100%: At least 25dB. On any frequency removed from the assigned frequency by more than 100%, but not more than 250%: At least 35 dB. On any frequency removed from the assigned frequency by more than 250%, of the authorized bandwidth: At least $43 + 10\log(P)$ dB.

Part 90.210(c) 12.5kHz Channel Spacing Not Equipped with a Low Pass Filter

For transmitters that are not equipped with an audio low pass filter pursuant to S90.211 (b), the power of any emission must be attenuated below the un-modulated carrier output power as follows; (1) On any frequency removed from the center of the authorized bandwidth by a displacement frequency (f_d in kHz) of more than 5 kHz but not more than 10 kHz: At least $83 \log(f_d/5)$ dB; (2) ON any frequency removed from the center of the authorized bandwidth by a displacement frequency (f_d in kHz) of more than 10 kHz, but not more than 250% of the authorized bandwidth: At least $29 \log(f_d^2/11)$ dB or 50 dB, whichever is the lesser attenuation; (3) On any frequency removed from the center of the authorized bandwidth by more than 250% of the authorized bandwidth: At least $43 + 10 \log(P_0)$ dB.

Part 90.210(d) Emission Mask D - 12.5 kHz channel BW equipment.

For transmitters designed to operate with a 12.5 kHz channel bandwidth, any emission must be attenuated below the power (P) of the highest emission contained within the authorized bandwidth as follows:

- (1) On any frequency from the center of the authorized bandwidth f_0 to 5.625 kHz removed from f_0 : Zero dB.
- (2) On any frequency from the center of the authorized bandwidth by a displacement frequency (f_d in kHz) of more than 5.625 kHz but no more than 12.5 kHz: At least $7.27(f_d - 2.88 \text{ kHz})$ dB.
- (3) On any frequency removed from the center of the authorized bandwidth by a displacement frequency (f_d in kHz) of more than 12.5 kHz: At least $50 + 10\log(P)$ dB or 70 dB, whichever is the lesser attenuation.

Part 90.210(e) Emission Mask E – 6.25 kHz channel BW equipment.

For transmitters designed to operate with a 6.25 kHz bandwidth, any emission must be attenuated below the power (P) of the highest emission contained within the authorized bandwidth as follows:

- (1) On any frequency from the center of the authorized bandwidth f_0 to 3.0 kHz removed from f_0 : Zero dB.
- (2) On any frequency from the center of the authorized bandwidth by a displacement frequency (f_d in kHz) of more than 3.0 kHz but no more than 4.6 kHz: At least $30 + 16.67(f_d - 3.0 \text{ kHz})$ or $55 + 10 \log(P)$ or 65, whichever is the lesser attenuation.
- (3) On any frequency removed from the center of the authorized bandwidth by more than 4.6kHz: At least $55 + 10\log(P)$ dB or 65 dB, whichever is the lesser attenuation.

Applicant: N. WILLIAM KOSTIS D/B/A SOUTHERN MAINE COMMUNICATIONS

FCC ID: 2ABEE12MIU

Report: N\N WILLIAM_2ABEE\209AUT14\209AUT14TestReport.docx

Method of Measurement: ANSI/TIA 603-C: 2004

Test Setup Diagram:

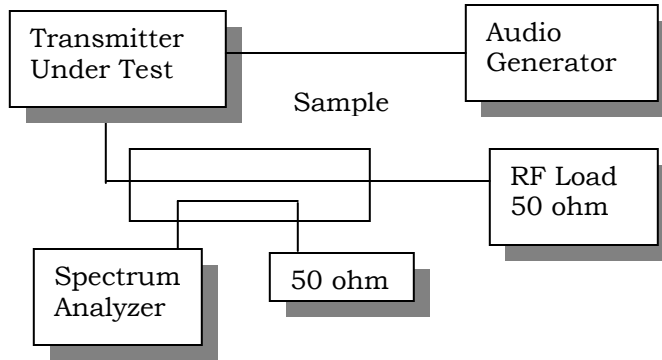

Test Data: See the plots below

OCCUPIED BANDWIDTH PLOTS Part 90.210(d) Emission Mask D - 12.5 kHz channel

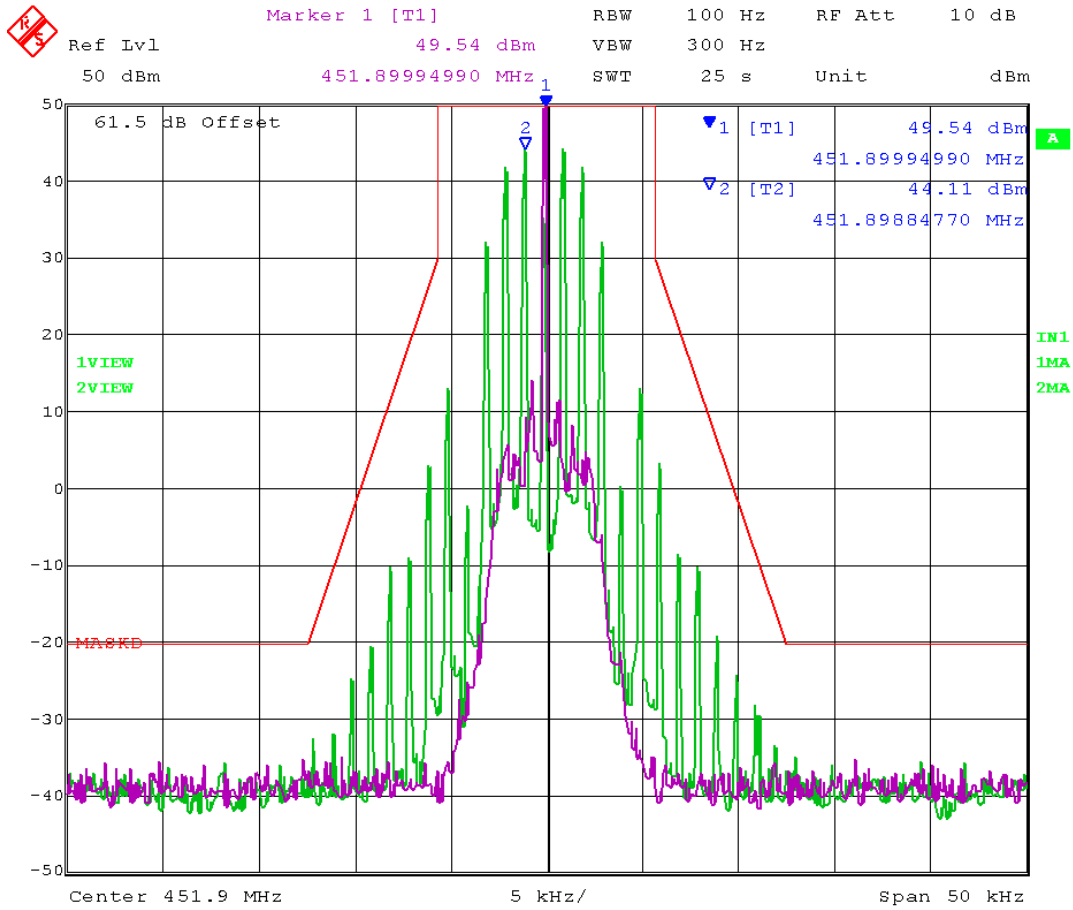

Date: 21.FEB.2014 09:41:32

TX CRYSTAL FREQUENCY: 451.900 MHz

OCCUPIED BANDWIDTH PLOTS
Part 90.210(d) Emission Mask D - 12.5 kHz channel

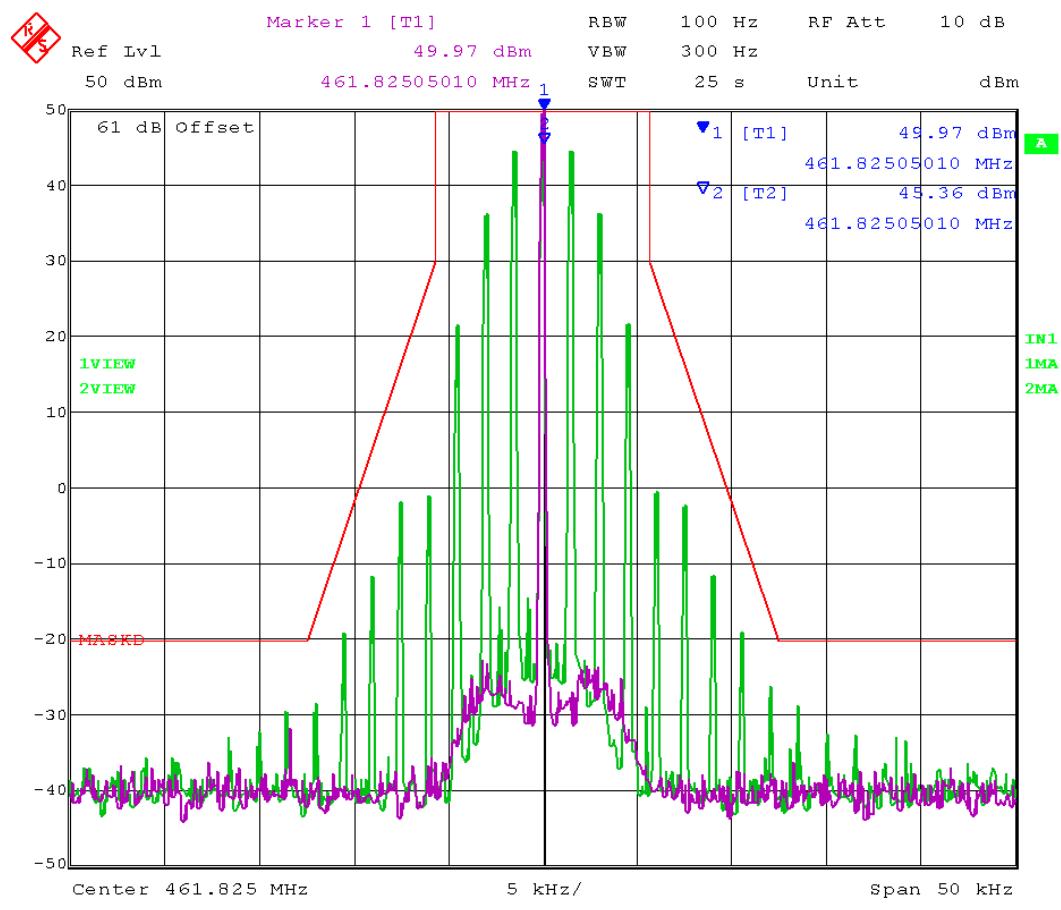

Date: 14.APR.2014 08:39:14

TX CRYSTAL FREQUENCY: 461.825 MHz

OCCUPIED BANDWIDTH PLOTS
Part 90.210(d) Emission Mask D - 12.5 kHz channel

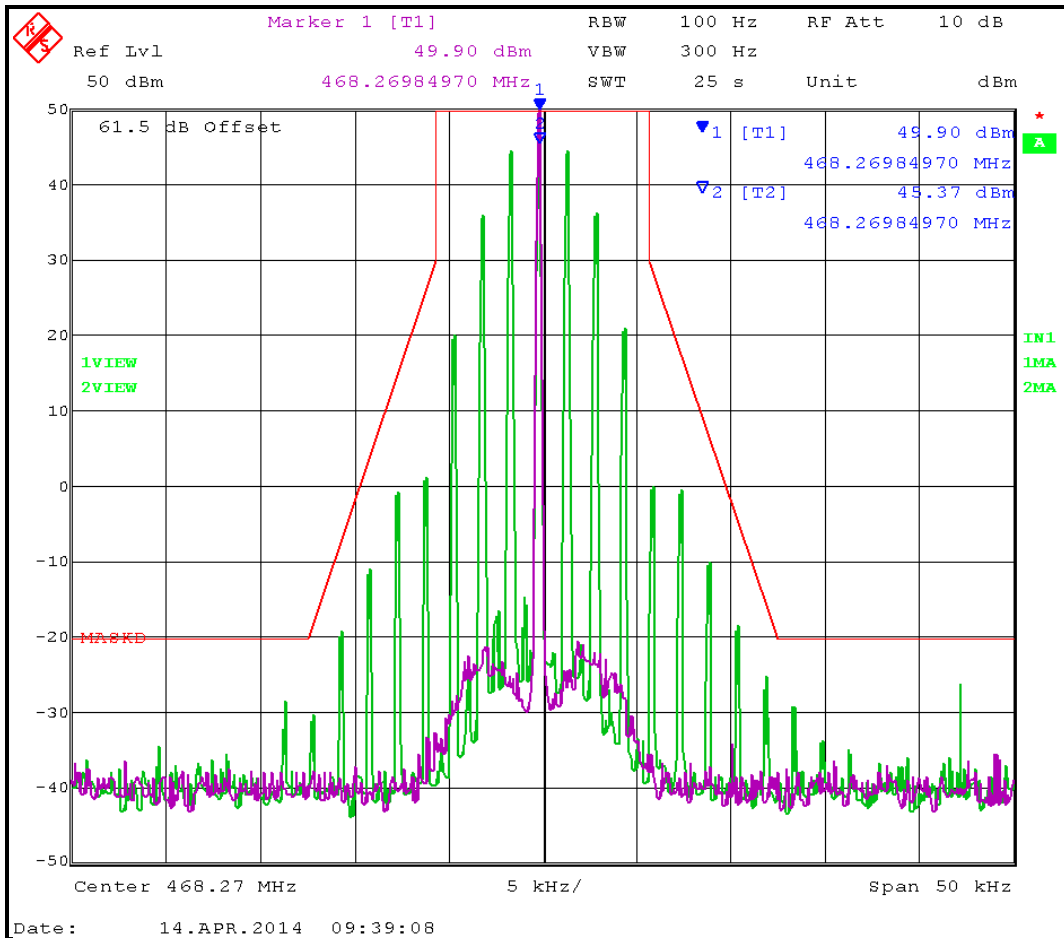

TX CRYSTAL FREQUENCY: 468.270 MHz

SPURIOUS EMISSIONS AT ANTENNA TERMINALS (CONDUCTED)

Rule Part No.: Part 2.1051(a)

Requirements:

- 12.5 kHz Channel Spacing = $50 + 10 \log(100.0) = 70.0$ dBc (high power)
- 12.5 kHz Channel Spacing = $50 + 10 \log(30.0) = 64.8$ dBc (low power)

Method of Measurement: The carrier was modulated 100% using a 2500 Hz tone. The spectrum was scanned from 0.4 to at least the 10th harmonic of the fundamental. The measurements were made in accordance with standard ANSI/TIA 603-C: 2004.

Method of Measuring Conducted Spurious Emissions

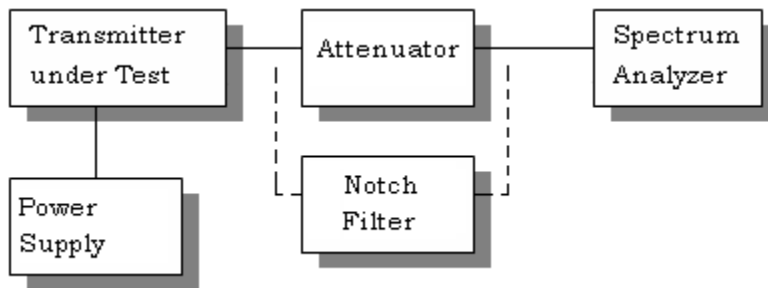

Test Data:

HIGH POWER LOW End of Band

LOW POWER LOW End of Band

TF HIGH POWER	EF	dB below carrier		TF LOW POWER	EF	dB below carrier
451.90	903.80	79		451.90	903.80	73.5
	1355.70	71.9			1355.70	68.2
	1807.60	72.3			1807.60	70.5
	2259.50	91			2259.50	83.4
	2711.40	91.5			2711.40	86.5
	3163.30	ne			3163.30	ne
	3615.20	ne			3615.20	ne
	4067.10	ne			4067.10	ne
	4519.00	ne			4519.00	ne

Ne: No emission found.



HIGH POWER: Mid of Band

LOW POWER: Mid of Band

TF HIGH POWER	EF	dB below carrier		TF LOW POWER	EF	dB below carrier
461.825	923.65	83.3		461.825	923.65	74.6
	1385.48	66.5			1385.48	67.5
	1847.30	85.8			1847.30	78.4
	2309.13	92.5			2309.13	90.3
	2770.95	80.4			2770.95	76.9
	3232.78	ne			3232.78	ne
	3694.60	ne			3694.60	ne
	4156.43	ne			4156.43	ne
	4618.25	ne			4618.25	ne

Ne: No emission found.

HIGH POWER: Mid of Band

LOW POWER: Mid of Band

TF HIGH POWER	EF	dB below carrier		TF LOW POWER	EF	dB below carrier
468.27	936.54	84		468.27	936.54	78.3
	1404.81	70.3			1404.81	71.4
	1873.08	73.6			1873.08	78.5
	2341.35	82.5			2341.35	77.9
	2809.62	84.5			2809.62	80
	3277.89	ne			3277.89	ne
	3746.16	ne			3746.16	ne
	4214.43	ne			4214.43	ne
	4682.70	ne			4682.70	ne

Ne: No emission found.

Method of Measuring Conducted Spurious Emissions

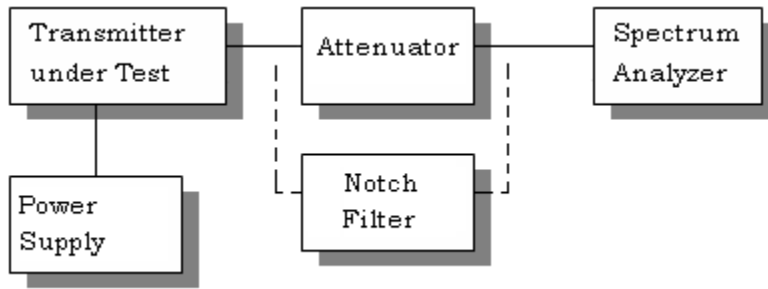

FIELD STRENGTH OF SPURIOUS EMISSIONS

Rule Parts. No.: Part 2.1053

Requirements:

12.5 kHz Channel Spacing = $50 + 10 \log(100.0) = 70.0$ dBc (high power)

12.5 kHz Channel Spacing = $50 + 10 \log(30.0) = 64.8$ dBc (low power)

METHOD OF MEASUREMENT: The tabulated data shows the results of the radiated field strength emissions test. The spectrum was scanned from 30 MHz to at least the tenth harmonic of the fundamental. This test was conducted per ANSI/TIA 603-C: 2004 using the substitution method. Measurements were made at the test site of TIMCO ENGINEERING, INC. located at 849 NW State Road 45, Newberry, FL 32669.

Test Setup Diagram:

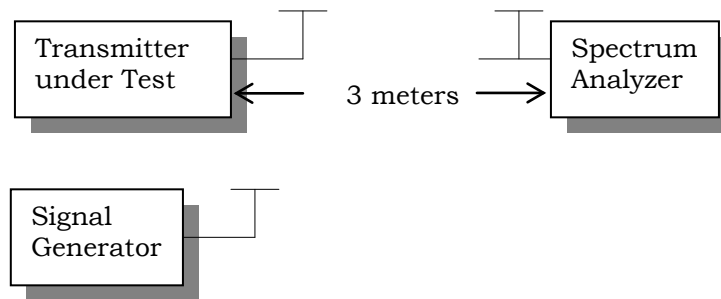

Test Data:

HIGH POWER: Low End of Band

Emission Frequency MHz	Ant. Polarity	dB Below Carrier (dBc)
451.90	0	0
903.80	H	88.9
1355.70	V	81.4
1807.60	V	81.0
2259.50	V	86.3
2711.40	V	85.1
3163.30	H/V	NE
3615.20	H/V	NE
4067.10	H/V	NE
4519.00	H/V	NE

LOW POWER: Low End of Band

Emission Frequency MHz	Ant. Polarity	dB Below Carrier (dBc)
451.90	0	0
903.80	H	81.1
1355.70	V	79.8
1807.60	V	79.8
2259.50	V	82.1
2711.40	V	82.6
3163.30	H/V	NE
3615.20	H/V	NE
4067.10	H/V	NE
4519.00	H/V	NE

HIGH POWER: Mid of Band

Emission Frequency MHz	Ant. Polarity	dB Below Carrier (dBc)
461.83	0	0
923.65	H	86.1
1385.48	V	81.7
1847.30	V	90.1
2309.13	V	87.7
2770.95	V	82.2
3232.78	H/V	NE
3694.60	H/V	NE
4156.43	H/V	NE
4618.25	H/V	NE

LOW POWER: Mid of Band

Emission Frequency MHz	Ant. Polarity	dB Below Carrier (dBc)
461.83	0	0
923.65	H	83.6
1385.48	V	77.5
1847.30	V	85.8
2309.13	V	90.2
2770.95	V	76.3
3232.78	H/V	NE
3694.60	H/V	NE
4156.43	H/V	NE
4618.25	H/V	NE

HIGH POWER: High End of Band

Emission Frequency MHz	Ant. Polarity	dB Below Carrier (dBc)
468.27	0	0
936.54	H	86.1
1404.81	V	88.2
1873.08	V	86.6
2341.35	V	88.7
2809.62	V	95.4
3277.89	V	94.0
3746.16	V	93.3
4214.43	H/V	NE
4682.70	H/V	NE

LOW POWER: High End of Band

Emission Frequency MHz	Ant. Polarity	dB Below Carrier (dBc)
468.27	0	0
936.54	H	82.4
1404.81	V	82.2
1873.08	V	85.6
2341.35	V	87.0
2809.62	V	83.2
3277.89	V	89.0
3746.16	V	89.7
4214.43	H/V	NE
4682.70	H/V	NE



FREQUENCY STABILITY

Rule Parts. No.: Part 2.1055, Part 90.213

Requirements: Temperature range requirements: -30 to +50° C.
Voltage Variation +, -15%
±2.5 PPM

Method of Measurements: ANSI/TIA 603-C: 2004.

Test Data:

Assigned Frequency (Ref. Frequency) (MHz)		453.424273
Temperature (°C)	Frequency (MHz)	Frequency Stability (PPM)
-30	453.425002	1.61
-20	453.425027	1.66
-10	453.425059	1.73
0	453.424293	0.04
+10	453.423861	-0.91
+20	453.424237	-0.08
+30	453.423832	-0.97
+40	453.423408	-1.91
+50	453.423207	-2.35

Assigned Frequency (Ref. Frequency) (MHz)		
% Battery	Frequency (MHz)	Frequency Stability (PPM)
-15%	453.424092	-0.40
0	453.424273	0.00
+15%	453.424076	-0.43



TRANSIENT FREQUENCY BEHAVIOR

Part 90.214 Transient Frequency Behavior

REQUIREMENTS: Transmitters designed to operate in the 150-174 MHz and 421-512 MHz frequency bands must maintain transient frequencies within the maximum transient frequencies within the maximum frequency difference limits during the time intervals indicated:

Time Intervals	Maximum frequency difference	All Equipment	
		150-174 MHz	421-512 MHz

Transient Frequency Behavior for Equipment Designed to Operate on 25 kHz Channels

t_1^4	± 25.0 kHz	5.0 ms	10.0 ms
t_2	± 12.5 kHz	20.0 ms	25.0 ms
t_3^4	± 25.0 kHz	5.0 ms	10.0 ms

Transient Frequency Behavior for Equipment Designed to Operate on 12.5 kHz Channels

t_1^4	± 12.5 kHz	5.0 ms	10.0 ms
t_2	± 6.25 kHz	20.0 ms	25.0 ms
t_3^4	± 12.5 kHz	5.0 ms	10.0 ms

Transient Frequency Behavior for Equipment Designed to Operate on 6.25 kHz Channels

t_1^4	± 6.25 kHz	5.0 ms	10.0 ms
t_2	± 3.125 kHz	20.0 ms	25.0 ms
t_3^4	± 6.25 kHz	5.0 ms	10.0 ms

Test Data:

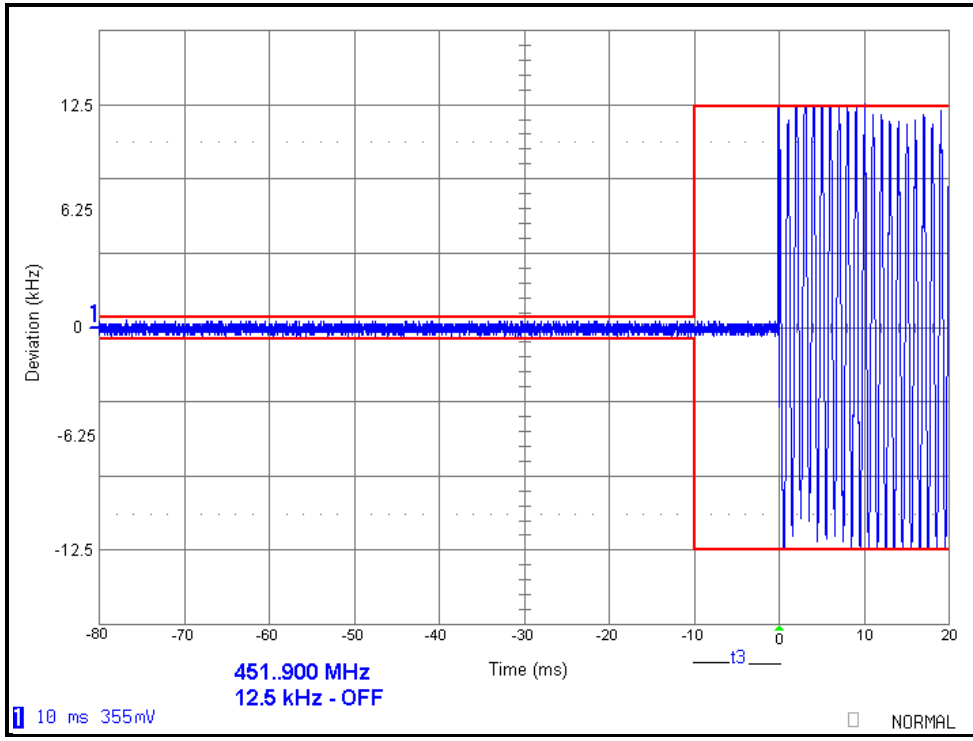
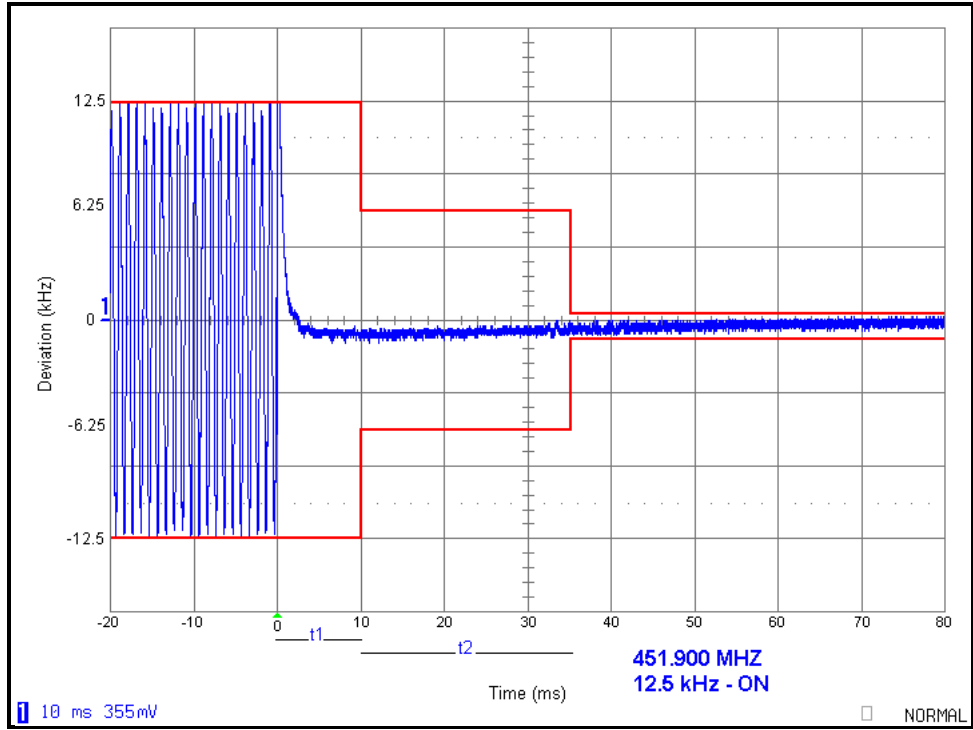

TEST PROCEEDURE: ANSI/TIA 603-C:2004, the levels were set as follows:

1. Using the variable attenuator the transmitter level was set to 40 dB below the test receivers maximum input level, then the transmitter was turned off.
2. With the transmitter off the signal generator was set 20dB below the level of the transmitter in the above step, this level will be maintained with the signal generator through-out the test.
3. Reduce the attenuation between the transmitter and the RF detector by 30 dB.
4. With the levels set as above, the transient frequency behavior was observed and recorded.

