

FCC RADIO TEST REPORT

FCC ID: 2ABE2BTS22C

IC: 12269A-BTS22C

Product : Bluetooth Speaker

Trade Name : N/A

Model Name : BTS22C

Serial Model : BTS22

Prepared for

GOLD FINGERS TECHNOLOGY CO.,LTD

Room 1403, 14F, Binhai Building B, xinghua road, central of Bao'an district
Shenzhen, P, R, China

Prepared by

DongGuan Precise Testing Service Co.,Ltd.

Room 203-204, 2F, Xinye Building, No.67 Shijing, Guanzhang
Road, Dongguan, China

TEST RESULT CERTIFICATION

Applicant's name GOLD FINGERS TECHNOLOGY CO.,LTD
Address Room 1403, 14F, Binhai Building B, xinghua road, central of Bao'an district, Shenzhen, P, R, China

Manufacture's Name... GOLD FINGERS TECHNOLOGY CO.,LTD
Address Room 1403, 14F, Binhai Building B, xinghua road, central of Bao'an district, Shenzhen, P, R, China

Product description

Product name Bluetooth Speaker
Model and/or type BTS22C
reference
Serial Model BTS22

Standards FCC Part15.247, RSS-210 Annex 8

Test procedure ANSI C63.10-2003, RSS-Gen Issue 3

This device described above has been tested by PTS, and the test results show that the equipment under test (EUT) is in compliance with the FCC requirements. And it is applicable only to the tested sample identified in the report.

This report shall not be reproduced except in full, without the written approval of PTS, this document may be altered or revised by PTS, personal only, and shall be noted in the revision of the document.

Date of Test

Date (s) of performance of tests 01, Aug. 2014 ~ 18, Aug. 2014

Date of Issue 29, Aug. 2014

Test Result..... **Pass**

Testing Engineer :

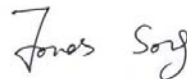

Assistant

Technical Manager :

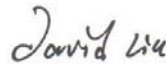

Supervisor

Authorized Signatory :



Jacky Ou / Manager

Table of Contents

	Page
1 . SUMMARY OF TEST RESULTS	5
1.1 TEST FACILITY	6
1.2 MEASUREMENT UNCERTAINTY	6
2 . GENERAL INFORMATION	7
2.1 GENERAL DESCRIPTION OF EUT	7
2.2 DESCRIPTION OF TEST MODES	9
2.3 BLOCK DIGRAM SHOWING THE CONFIGURATION OF SYSTEM TESTED	10
2.4 DESCRIPTION OF SUPPORT UNITS(CONDUCTED MODE)	11
2.5 EQUIPMENTS LIST FOR ALL TEST ITEMS	12
3 . EMC EMISSION TEST	13
3.1 CONDUCTED EMISSION MEASUREMENT	13
3.1.1 POWER LINE CONDUCTED EMISSION LIMITS	13
3.1.2 TEST PROCEDURE	14
3.1.3 DEVIATION FROM TEST STANDARD	14
3.1.4 TEST SETUP	14
3.1.5 EUT OPERATING CONDITIONS	14
3.1.6 TEST RESULTS	15
3.2 RADIATED EMISSION MEASUREMENT	17
3.2.1 RADIATED EMISSION LIMITS	17
3.2.2 TEST PROCEDURE	18
3.2.3 DEVIATION FROM TEST STANDARD	18
3.2.4 TEST SETUP	19
3.2.5 EUT OPERATING CONDITIONS	20
3.2.6 TEST RESULTS (BETWEEN 9KHZ – 30 MHZ)	21
3.2.7 TEST RESULTS (BETWEEN 30MHZ – 1GHZ)	22
3.2.8 TEST RESULTS (ABOVE 1000 MHZ)	23
4 . POWER SPECTRAL DENSITY TEST	30
4.1 APPLIED PROCEDURES / LIMIT	30
4.1.1 TEST PROCEDURE	30
4.1.2 DEVIATION FROM STANDARD	30
4.1.3 TEST SETUP	30
4.1.4 EUT OPERATION CONDITIONS	30
4.1.5 TEST RESULTS	31
5 . BANDWIDTH TEST	32
5.1 APPLIED PROCEDURES / LIMIT	32
5.1.1 TEST PROCEDURE	32

Table of Contents

	Page
5.1.2 EUT OPERATION CONDITIONS	32
5.1.3 TEST RESULTS	33
6 . PEAK OUTPUT POWER TEST	35
6.1 APPLIED PROCEDURES / LIMIT	35
6.1.1 TEST PROCEDURE	35
6.1.2 DEVIATION FROM STANDARD	35
6.1.3 TEST SETUP	35
6.1.4 EUT OPERATION CONDITIONS	35
6.1.5 TEST RESULTS	36
7 . 100 KHZ BANDWIDTH OF FREQUENCY BAND EDGE	37
7.1 DEVIATION FROM STANDARD	37
7.2 TEST SETUP	37
7.3 EUT OPERATION CONDITIONS	37
7.4 TEST RESULTS	38
8 . ANTENNA REQUIREMENT	40
8.1 STANDARD REQUIREMENT	40
8.2 EUT ANTENNA	40
9 . EUT TEST PHOTO	41
APPENDIX-PHOTOGRAPHS OF EUT CONSTRUCTIONAL DETAILS	

1. SUMMARY OF TEST RESULTS

Test procedures according to the technical standards:

FCC Part15 (15.247) , Subpart C & RSS-210 Annex 8			
Standard Section	Test Item	Judgment	Remark
15.207&7.2.4	Conducted Emission	PASS	
15.247 (a)(2)& A8.1	6dB Bandwidth	PASS	
15.247 (b)& A8.4	Peak Output Power	PASS	
15.247 (c) & A8.5	Radiated Spurious Emission	PASS	
15.247 (d) & A8.2	Power Spectral Density	PASS	
15.205& A8.5	Band Edge Emission	PASS	
15.203	Antenna Requirement	PASS	

NOTE:

(1) "N/A" denotes test is not applicable in this Test Report

1.1 TEST FACILITY

NTEK Testing Technology Co., Ltd
 Add.:1/F, Building E, Fenda Science Park, Sanwei Community, Xixiang Street, Bao'an District, Shenzhen P.R. China.
 FCC Registration No.:238937; IC Registration No.:9270A-1
 CNAS Registration No.:L5516

1.2 MEASUREMENT UNCERTAINTY

The reported uncertainty of measurement $y \pm U$, where expanded uncertainty U is based on a standard uncertainty multiplied by a coverage factor of $k=2$, providing a level of confidence of approximately 95%.

No.	Item	Uncertainty
1	Conducted Emission Test	$\pm 1.38\text{dB}$
2	RF power,conducted	$\pm 0.16\text{dB}$
3	Spurious emissions,conducted	$\pm 0.21\text{dB}$
4	All emissions,radiated(<1G)	$\pm 4.68\text{dB}$
5	All emissions,radiated(>1G)	$\pm 4.89\text{dB}$
6	Temperature	$\pm 0.5^\circ\text{C}$
7	Humidity	$\pm 2\%$

2. GENERAL INFORMATION

2.1 GENERAL DESCRIPTION OF EUT

Equipment	Bluetooth Speaker	
Trade Name	N/A	
Model Name	BTS22C	
Serial Model	BTS22	
Model Difference	The only difference is the model name.	
Product Description	The EUT is a Bluetooth Speaker	
	Operation Frequency:	2402~2480MHz
	Modulation Type:	GFSK
	Bluetooth version:	4.0
	Bit Rate of Transmitter	1 Mbps
	Number Of Channel	40CH
	Antenna Designation:	Please see Note 3.
	Output Power(Conducted):	-2.09dBm
	Antenna Gain (dBi)	0dbi
	Based on the application, features, or specification exhibited in User's Manual, the EUT is considered as an ITE/Computing Device. More details of EUT technical specification, please refer to the User's Manual.	
Channel List	Please refer to the Note 2.	
Ratings	DC 3.7V from Battery or DC 5V from USB	
Adapter	N/A	
Battery	N/A	

Note:

- 1.1 For a more detailed features description, please refer to the manufacturer's specifications or the User's Manual.
- 1.2 All modes were tested accordingly, and only the worst mode data were shown in this report.

2.

Channel	Frequency (MHz)
00	2402
01	2404
.....
.....
.....	...
.....
38	2478
39	2480

3.

Table for Filed Antenna

Ant	Brand	Model Name	Antenna Type	Connector	Gain (dBi)	NOTE
A	N/A	N/A	PCB Antenna	N/A	0	BT Antenna

2.2 DESCRIPTION OF TEST MODES

To investigate the maximum EMI emission characteristics generates from EUT, the test system was pre-scanning tested base on the consideration of following EUT operation mode or test configuration mode which possible have effect on EMI emission level. Each of these EUT operation mode(s) or test configuration mode(s) mentioned above was evaluated respectively.

Pretest Mode	Description
Mode 1	CH00
Mode 2	CH19
Mode 3	CH39
Mode 4	TX Mode

For Conducted Emission	
Final Test Mode	Description
Mode 4	TX Mode

For Radiated Emission	
Final Test Mode	Description
Mode 1	CH00
Mode 2	CH19
Mode 3	CH39
Mode 4	TX Mode

Note:

- (1) The measurements are performed at the highest, middle, lowest available channels.
- (2) The measurements are performed at all Bit Rate of Transmitter, the worst data was reported
- (3) The EUT was programmed to be in continuously transmitting mode and the transmit duty cycle is not less than 98%.

2.3 BLOCK DIGRAM SHOWING THE CONFIGURATION OF SYSTEM TESTED

Conducted Emission Test

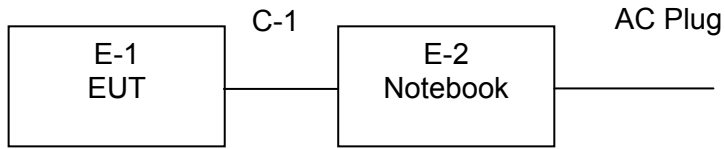

Radiated Spurious Emission Test

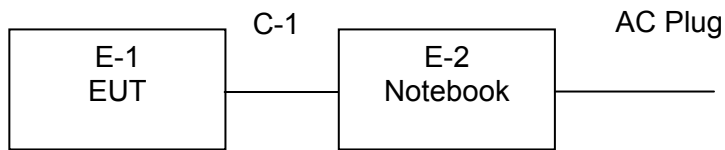

2.4 DESCRIPTION OF SUPPORT UNITS(CONDUCTED MODE)

The EUT has been tested as an independent unit together with other necessary accessories or support units. The following support units or accessories were used to form a representative test configuration during the tests.

Item	Equipment	Brand	Model/Type No.	Series No.	Note
E-1	Bluetooth Speaker	N/A	BTS22C	N/A	EUT
E-2	Notebook	Sony	PCG-51111T	N/A	N/A

Item	Shielded Type	Ferrite Core	Length	Note
C-1	NO	NO	0.85m	

Note:

- (1) The support equipment was authorized by Declaration of Confirmation.
- (2) For detachable type I/O cable should be specified the length in cm in 『Length』 column.

2.5 EQUIPMENTS LIST FOR ALL TEST ITEMS

Radiation Test equipment

Item	Kind of Equipment	Manufacturer	Type No.	Serial No.	Last calibration	Calibrated until	Calibration period
1	Spectrum Analyzer	Agilent	E4407B	MY45108040	2014.07.06	2015.07.05	1 year
2	Test Receiver	R&S	ESPI	101318	2014.06.07	2015.06.06	1 year
3	Bilog Antenna	TESEQ	CBL6111D	31216	2014.07.06	2015.07.05	1 year
4	50Ω Coaxial Switch	Anritsu	MP59B	6200264416	2014.06.07	2015.06.06	1 year
5	Spectrum Analyzer	ADVANTEST	R3132	150900201	2014.06.07	2015.06.06	1 year
6	Horn Antenna	EM	EM-AH-10180	2011071402	2014.07.06	2015.07.05	1 year
7	Horn Ant	Schwarzbeck	BBHA 9170	9170-181	2014.07.06	2015.07.05	1 year
8	Amplifier	EM	EM-30180	060538	2013.12.22	2014.12.21	1 year
9	Loop Antenna	ARA	PLA-1030/B	1029	2014.06.08	2015.06.07	1 year
10	Power Meter	R&S	NRVS	100696	2014.07.06	2015.07.05	1 year
11	Power Sensor	R&S	URV5-Z4	0395.1619.05	2014.07.06	2015.07.05	1 year
12	RF cable	PTS	40 CM	N/A	2014.07.01	2015.06.30	1 year

Conduction Test equipment

Item	Kind of Equipment	Manufacturer	Type No.	Serial No.	Last calibration	Calibrated until	Calibration period
1	Test Receiver	R&S	ESCI	101160	2014.06.06	2015.06.05	1 year
2	LISN	R&S	ENV216	101313	2013.08.24	2014.08.23	1 year
3	LISN	EMCO	3816/2	00042990	2013.08.24	2014.08.23	1 year
4	50Ω Coaxial Switch	Anritsu	MP59B	6200264417	2014.06.07	2015.06.06	1 year
5	Passive Voltage Probe	R&S	ESH2-Z3	100196	2014.06.07	2015.06.06	1 year
6	Absorbing clamp	R&S	MOS-21	100423	2014.06.08	2015.06.07	1 year
7	Coaxial cable	PTS	200 CM	N/A	2014.07.01	2015.06.30	1 year

1	Attenuation	MCE	24-10-34	BN9258	2014.06.08	2015.06.07	1 year
---	-------------	-----	----------	--------	------------	------------	--------

3. EMC EMISSION TEST

3.1 CONDUCTED EMISSION MEASUREMENT

3.1.1 POWER LINE CONDUCTED EMISSION Limits (Frequency Range 150KHz-30MHz)

FREQUENCY (MHz)	Class A (dBuV)		Class B (dBuV)		Standard
	Quasi-peak	Average	Quasi-peak	Average	
0.15 -0.5	79.00	66.00	66 - 56 *	56 - 46 *	CISPR
0.50 -5.0	73.00	60.00	56.00	46.00	CISPR
5.0 -30.0	73.00	60.00	60.00	50.00	CISPR

0.15 -0.5	79.00	66.00	66 - 56 *	56 - 46 *	FCC
0.50 -5.0	73.00	60.00	56.00	46.00	FCC
5.0 -30.0	73.00	60.00	60.00	50.00	FCC

Note:

- (1) The tighter limit applies at the band edges.
- (2) The limit of " * " marked band means the limitation decreases linearly with the logarithm of the frequency in the range.

The following table is the setting of the receiver

Receiver Parameters	Setting
Attenuation	10 dB
Start Frequency	0.15 MHz
Stop Frequency	30 MHz
IF Bandwidth	9 kHz

3.1.2 TEST PROCEDURE

- a. The EUT was placed 0.8 meters from the horizontal ground plane with EUT being connected to the power mains through a line impedance stabilization network (LISN). All other support equipments powered from additional LISN(s). The LISN provide 50 Ohm/ 50uH of coupling impedance for the measuring instrument.
- b. Interconnecting cables that hang closer than 40 cm to the ground plane shall be folded back and forth in the center forming a bundle 30 to 40 cm long.
- c. I/O cables that are not connected to a peripheral shall be bundled in the center. The end of the cable may be terminated, if required, using the correct terminating impedance. The overall length shall not exceed 1 m.
- d. LISN at least 80 cm from nearest part of EUT chassis.
- e. For the actual test configuration, please refer to the related Item –EUT Test Photos.

3.1.3 DEVIATION FROM TEST STANDARD

No deviation

3.1.4 TEST SETUP

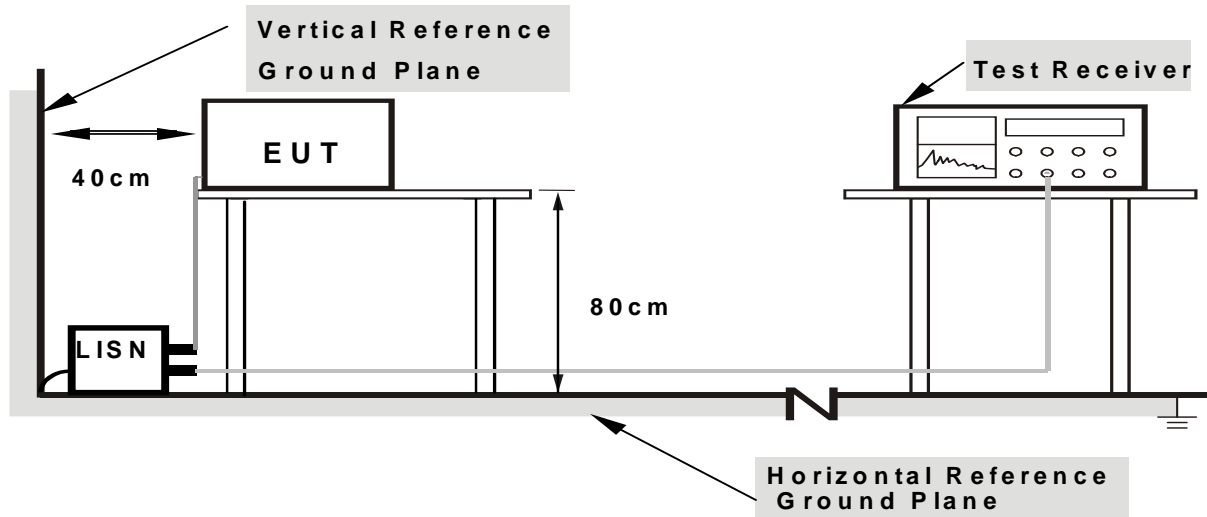

Note: 1. Support units were connected to second LISN.

2. Both of LISNs (AMN) are 80 cm from EUT and at least 80 from other units and other metal planes

3.1.5 EUT OPERATING CONDITIONS

The EUT was configured for testing in a typical fashion (as a customer would normally use it). The EUT has been programmed to continuously transmit during test. This operating condition was tested and used to collect the included data.

3.1.6 TEST RESULTS

EUT :	Bluetooth Speaker	Model Name. :	BTS22C
Temperature :	26 °C	Relative Humidity :	56%
Pressure :	1010hPa	Phase :	L
Test Voltage :	DC 5V form USB AC 120V/60Hz	Test Mode :	Mode 4

Freq MHz	Reading dBuV	Factor dB	Result dBuV/m	Limit dBuV/m	Over Limit dB	Remark	Phase
0.47	46.95	1.30	48.25	56.49	-8.24	Peak	LINE
0.54	45.86	1.30	47.16	56.00	-8.84	Peak	LINE
0.88	43.79	1.31	45.10	56.00	-10.90	Peak	LINE
1.24	41.18	1.32	42.50	56.00	-13.50	Peak	LINE

Remark:
 1. All readings are Quasi-Peak and Average values.
 2. Factor = Insertion Loss + Cable Loss.

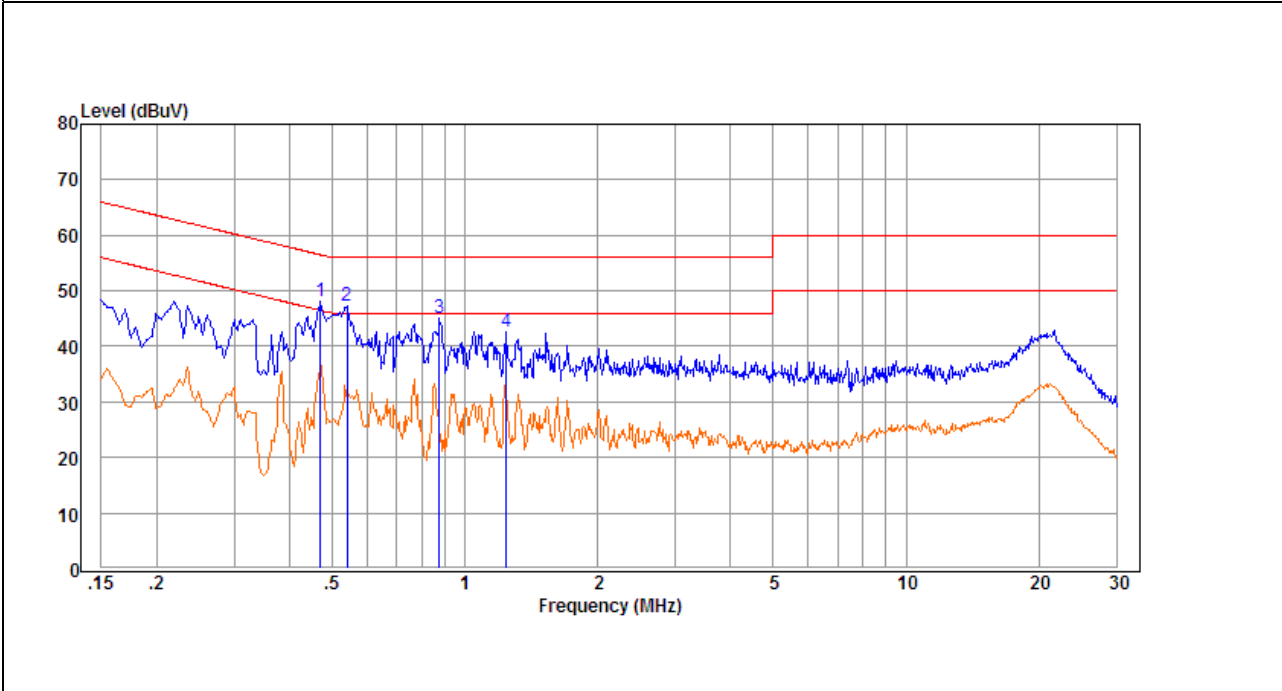

EUT :	Bluetooth Speaker	Model Name. :	BTS22C
Temperature :	26 °C	Relative Humidity :	56%
Pressure :	1010hPa	Phase :	N
Test Voltage :	DC 5V form USB AC 120V/60Hz	Test Mode :	Mode 4

Freq MHz	Reading dBuV	Factor dB	Result dBuV/m	Limit dBuV/m	Over Limit dB	Remark	Phase
0.53	43.05	1.30	44.35	56.00	-11.65	Peak	NEUTRAL
0.74	41.22	1.31	42.53	56.00	-13.47	Peak	NEUTRAL
0.87	44.35	1.31	45.66	56.00	-10.34	Peak	NEUTRAL
1.07	38.54	1.32	39.86	56.00	-16.14	Peak	NEUTRAL

Remark:
 1. All readings are Quasi-Peak and Average values.
 2. Factor = Insertion Loss + Cable Loss.

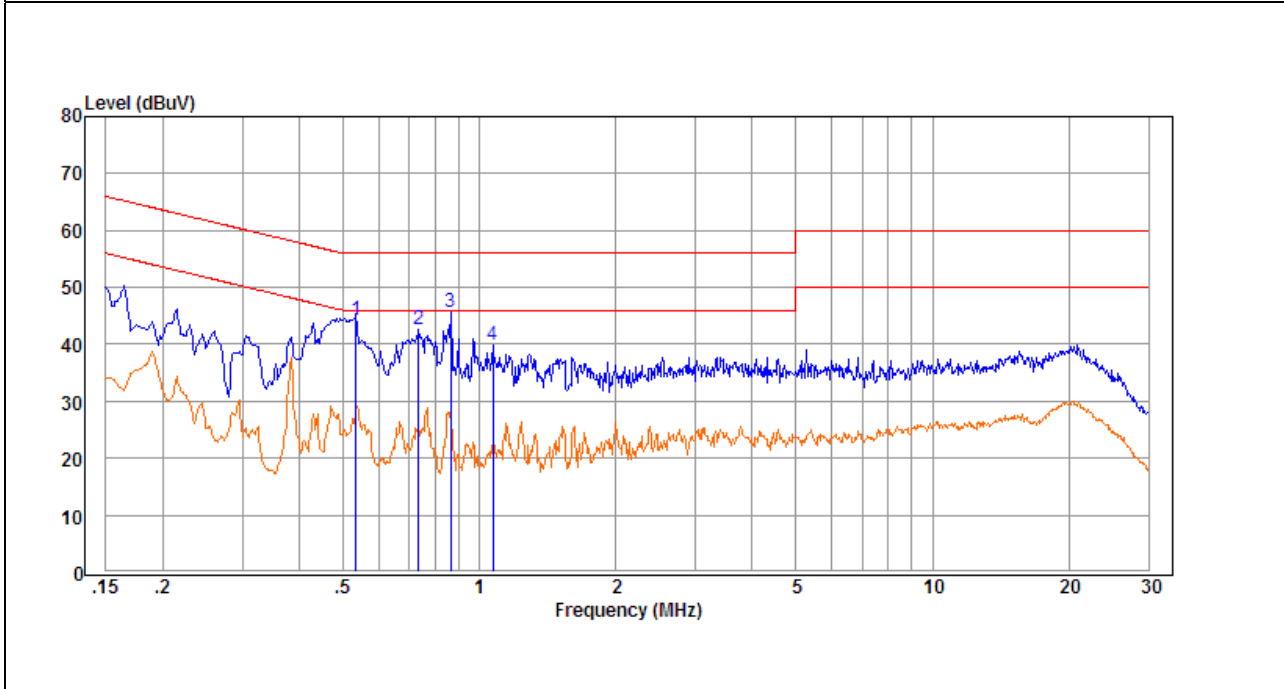

3.2 RADIATED EMISSION MEASUREMENT

3.2.1 RADIATED EMISSION LIMITS (Frequency Range 9kHz-1000MHz)

20dBc in any 100 kHz bandwidth outside the operating frequency band. In case the emission fall within the restricted band specified on 15.205(a)&A8.5, then the 15.209(a) limit in the table below has to be followed.

In any 100 kHz bandwidth outside the frequency band in which the spread spectrum or digitally modulated device is operating, the RF power that is produced shall be at least 20 dB below that in the 100 kHz bandwidth within the band that contains the highest level of the desired power, based on either an RF conducted or a radiated measurement, provided that the transmitter demonstrates compliance with the peak conducted power limits. If the transmitter complies with the conducted power limits based on the use of root-mean-square averaging over a time interval, as permitted under Section A8.4 (4), the attenuation required shall be 30 dB instead of 20 dB. Attenuation below the general field strength limits specified in RSS-Gen is not required.

Frequencies (MHz)	Field Strength (micorvolts/meter)	Measurement Distance (meters)
0.009~0.490	2400/F(KHz)	300
0.490~1.705	24000/F(KHz)	30
1.705~30.0	30	30
30~88	100	3
88~216	150	3
216~960	200	3
Above 960	500	3

LIMITS OF RADIATED EMISSION MEASUREMENT (Above 1000MHz)

FREQUENCY (MHz)	Class A (dBuV/m) (at 3M)		Class B (dBuV/m) (at 3M)	
	PEAK	AVERAGE	PEAK	AVERAGE
Above 1000	80	60	74	54

Notes:

- (1) Emission level (dBuV/m)=20log Emission level (uV/m).

Spectrum Parameter	Setting
Attenuation	Auto
Start Frequency	1000 MHz
Stop Frequency	10th carrier harmonic
RB / VB (emission in restricted band)	1 MHz / 1 MHz for Peak, 1 MHz / 10Hz for Average

Receiver Parameter	Setting
Attenuation	Auto
Start ~ Stop Frequency	9kHz~150kHz / RB 200Hz for QP
Start ~ Stop Frequency	150kHz~30MHz / RB 9kHz for QP
Start ~ Stop Frequency	30MHz~1000MHz / RB 120kHz for QP

3.2.2 TEST PROCEDURE

- a. The measuring distance of at 3 m shall be used for measurements at frequency up to 1GHz. For frequencies above 1GHz, any suitable measuring distance may be used.
- b. The EUT was placed on the top of a rotating table 0.8 meters above the ground at a 3 meter open area test site. The table was rotated 360 degrees to determine the position of the highest radiation.
- c. The height of the equipment or of the substitution antenna shall be 0.8 m; the height of the test antenna shall vary between 1 m to 4 m. Both horizontal and vertical polarizations of the antenna are set to make the measurement.
- d. The initial step in collecting conducted emission data is a spectrum analyzer peak detector mode pre-scanning the measurement frequency range. Significant peaks are then marked and then Quasi Peak detector mode re-measured.
- e. If the Peak Mode measured value compliance with and lower than Quasi Peak Mode Limit, the EUT shall be deemed to meet QP Limits and then no additional QP Mode measurement performed.
- f. For the actual test configuration, please refer to the related Item –EUT Test Photos.

Note:

Both horizontal and vertical antenna polarities were tested and performed pretest to three orthogonal axis. The worst case emissions were reported

3.2.3 DEVIATION FROM TEST STANDARD

No deviation

3.2.4 TEST SETUP

(A) Radiated Emission Test-Up Frequency Below 30MHz

5.2 Block Diagram of Test Setup

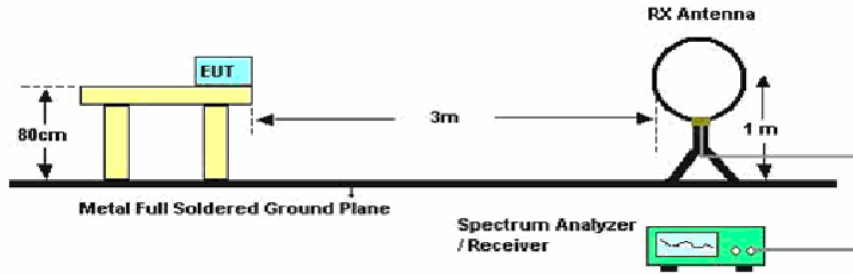

Below 30MHz

(B) Radiated Emission Test-Up Frequency 30MHz~1GHz

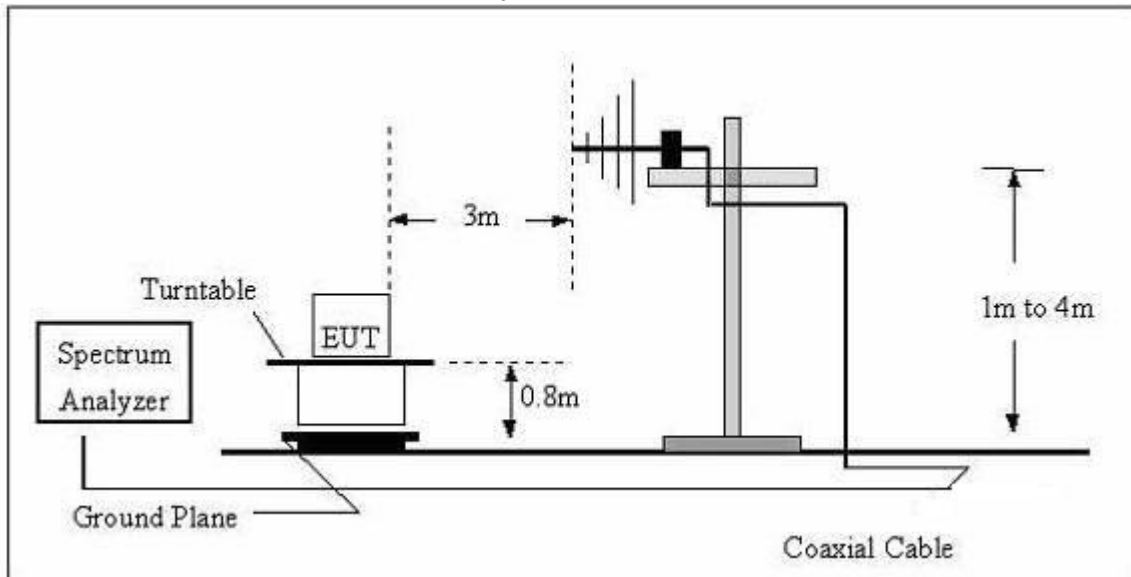

(C) Radiated Emission Test-Up Frequency Above 1GHz

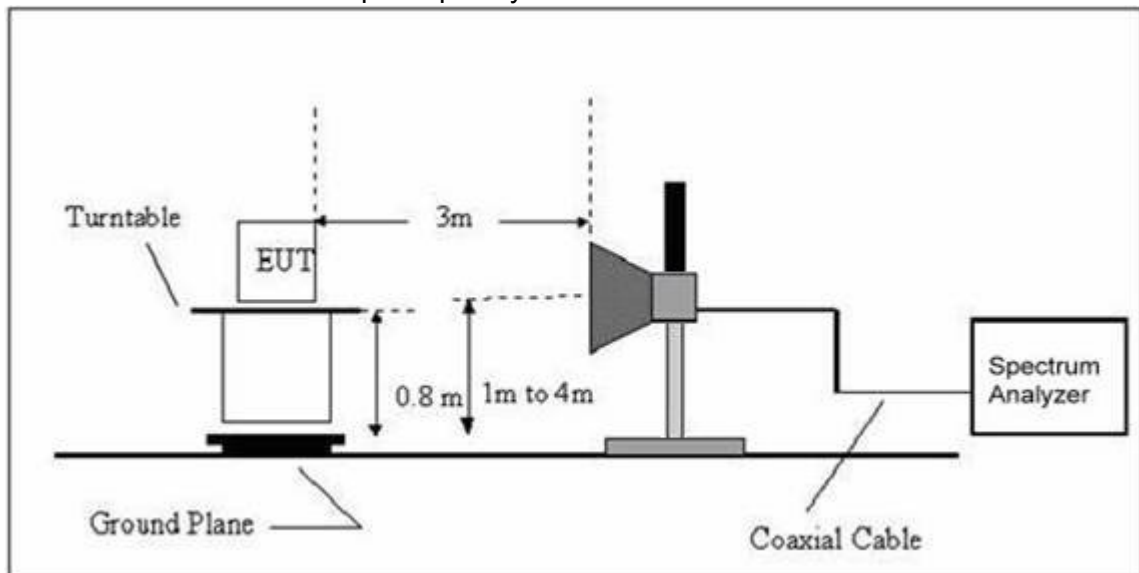

3.2.5 EUT OPERATING CONDITIONS

The EUT tested system was configured as the statements of 2.4 Unless otherwise a special operating condition is specified in the follows during the testing.

3.2.6 TEST RESULTS (BETWEEN 9KHZ – 30 MHZ)

EUT:	Bluetooth Speaker	Model Name. :	BTS22C
Temperature:	20 °C	Relative Humidity:	51%
Pressure:	1010 hPa	Test Voltage :	DC 5V from AC 120V/60Hz
Test Mode :	TX	Polarization :	--

Freq.	Reading	Limit	Margin	State
(MHz)	(dBuV/m)	(dBuV/m)	(dB)	P/F
--	--	--	--	N/A
--	--	--	--	N/A

NOTE:

The amplitude of spurious emissions which are attenuated by more than 20dB below the permissible value has no need to be reported.

Distance extrapolation factor = $40 \log(\text{specific distance}/\text{test distance})$ (dB);

Limit line = specific limits(dBuv) + distance extrapolation factor.

3.2.7 TEST RESULTS (BETWEEN 30MHZ – 1GHZ)

EUT :	Bluetooth Speaker	Model Name :	BTS22C
Temperature :	20 °C	Relative Humidity :	51%
Pressure:	1010 hPa	Test Voltage :	DC 5V form AC 120V/60Hz
Test Mode :	TX		

Polar (H/V)	Frequency	Meter Reading	Factor	Emission Level	Limits	Margin	Detector Type
	(MHz)	(dBuV)	(dB)	(dBuV/m)	(dBuV/m)	(dB)	
V	53.2156	20.79	7.14	27.93	40.00	-12.07	QP
V	144.5647	11.41	12.03	23.44	43.50	-20.06	QP
V	219.1243	12.67	10.27	22.94	46.00	-23.06	QP
V	245.1021	10.45	12.68	23.13	46.00	-22.87	QP
V	406.0902	6.64	18.54	25.18	46.00	-20.82	QP
V	625.1034	8.21	23.60	31.81	46.00	-14.19	QP
H	31.0691	6.38	17.86	24.24	40.00	-15.76	QP
H	168.4133	13.63	10.54	24.17	43.50	-19.33	QP
H	251.1817	14.57	13.68	28.25	46.00	-17.75	QP
H	422.0574	6.33	18.99	25.32	46.00	-20.68	QP
H	625.0802	8.23	23.60	31.83	46.00	-14.17	QP
H	896.9957	11.49	27.75	39.24	46.00	-6.76	QP
Remark:							
Absolute Level= ReadingLevel+ Factor, Margin= Absolute Level - Limit							

3.2.8 TEST RESULTS (ABOVE 1000 MHZ)

Frequency (MHz)	Reading (dBμV)	Factor (dB)	Corrected Amplitude (dBμV/m)	Limit (dBμV/m)	Margin (dB)	Detector (PK/QP/AV)	Polar (H/V)
Low Channel (2402 MHz)-Above 1G							
4804	62.33	-3.64	58.69	74	-15.31	Pk	Vertical
4804	46.35	-3.64	42.71	54	-11.29	AV	Vertical
7206	55.71	-0.95	54.76	74	-19.24	Pk	Vertical
7206	40.61	-0.95	39.66	54	-14.34	AV	Vertical
4804	62.13	-3.64	58.49	74	-15.51	Pk	Horizontal
4804	44.58	-3.64	40.94	54	-13.06	AV	Horizontal
7206	55.44	-0.95	54.49	74	-19.51	Pk	Horizontal
7206	40.69	-0.95	39.74	54	-14.26	AV	Horizontal
Mid Channel (2440 MHz)-Above 1G							
4880	63.15	-3.68	59.47	74	-14.53	Pk	Vertical
4880	45.43	-3.68	41.75	54	-12.25	AV	Vertical
7320	55.24	-0.82	54.42	74	-19.58	Pk	Vertical
7320	40.31	-0.82	39.49	54	-14.51	AV	Vertical
4880	62.78	-3.68	59.1	74	-14.90	Pk	Horizontal
4880	46.19	-3.68	42.51	54	-11.49	AV	Horizontal
7320	55.14	-0.82	54.32	74	-19.68	Pk	Horizontal
7320	40.66	-0.82	39.84	54	-14.16	AV	Horizontal
High Channel (2480MHz)- Above 1G							
4960	62.47	-3.59	58.88	74	-15.12	Pk	Vertical
4960	45.81	-3.59	42.22	54	-11.78	AV	Vertical
7440	55.68	-0.69	54.99	74	-19.01	Pk	Vertical
7440	39.42	-0.69	38.73	54	-15.27	AV	Vertical
4960	62.26	-3.59	58.67	74	-15.33	Pk	Horizontal
4960	45.22	-3.59	41.63	54	-12.37	AV	Horizontal
7440	55.38	-0.69	54.69	74	-19.31	Pk	Horizontal
7440	39.54	-0.69	38.85	54	-15.15	AV	Horizontal

Conducted Spurious Emissions at Antenna Port: Low Channel

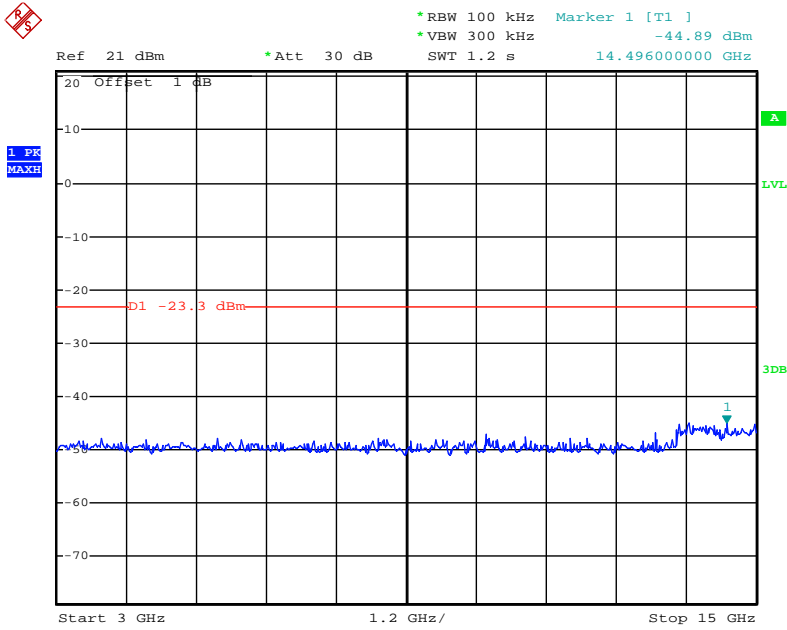
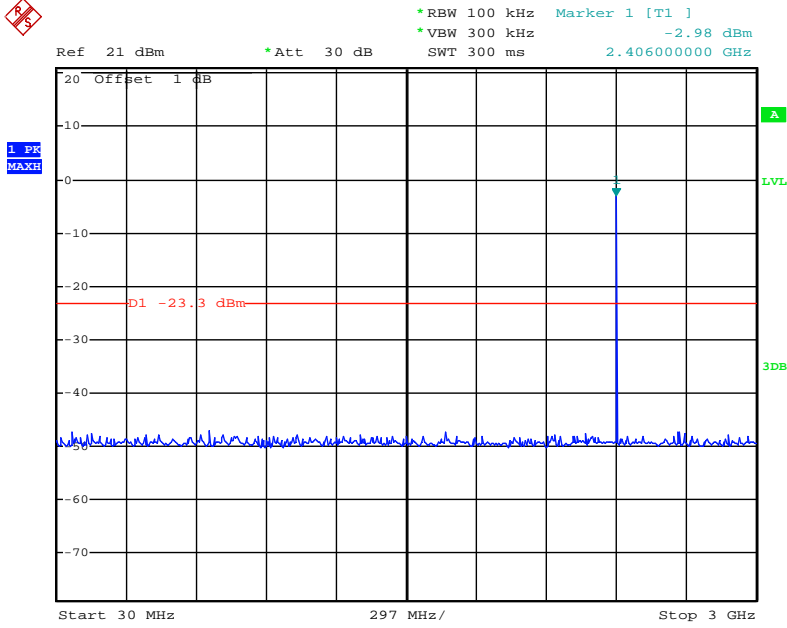

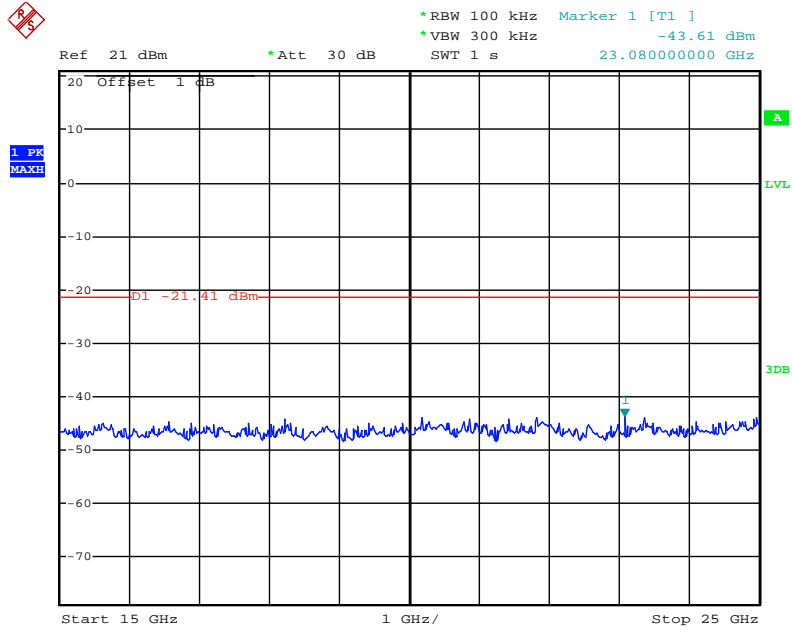

Middle Channel

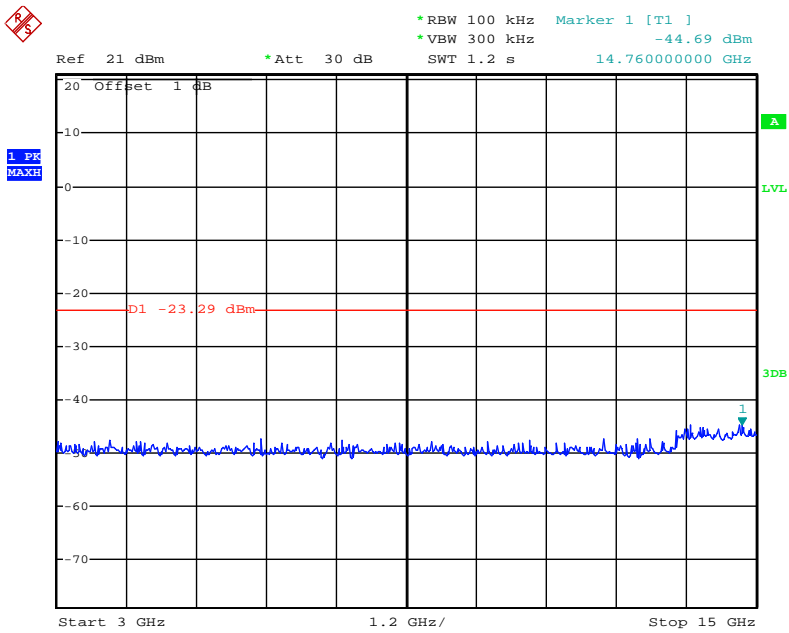
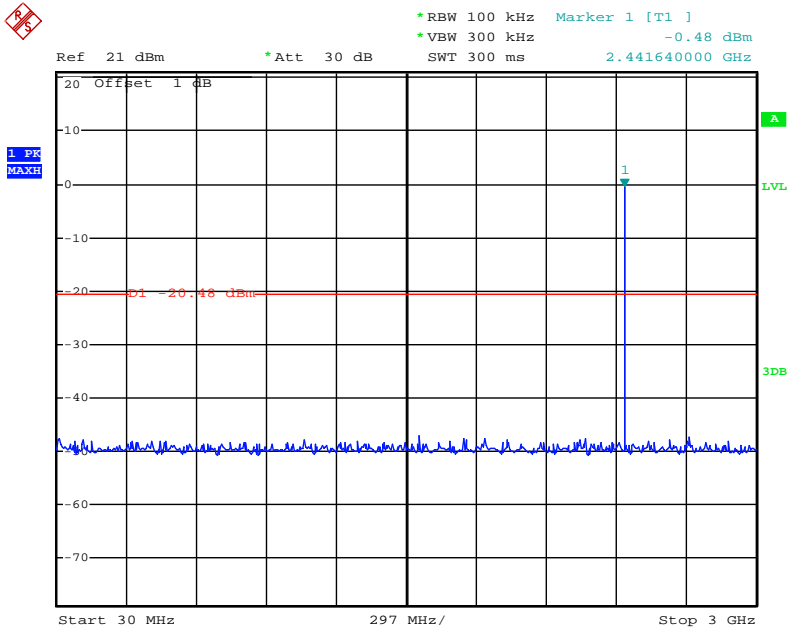



*RBW 100 kHz Marker 1 [T1]
*VBW 300 kHz -43.49 dBm
Ref 21 dBm *Att 30 dB SWT 1 s 24.62000000 GHz

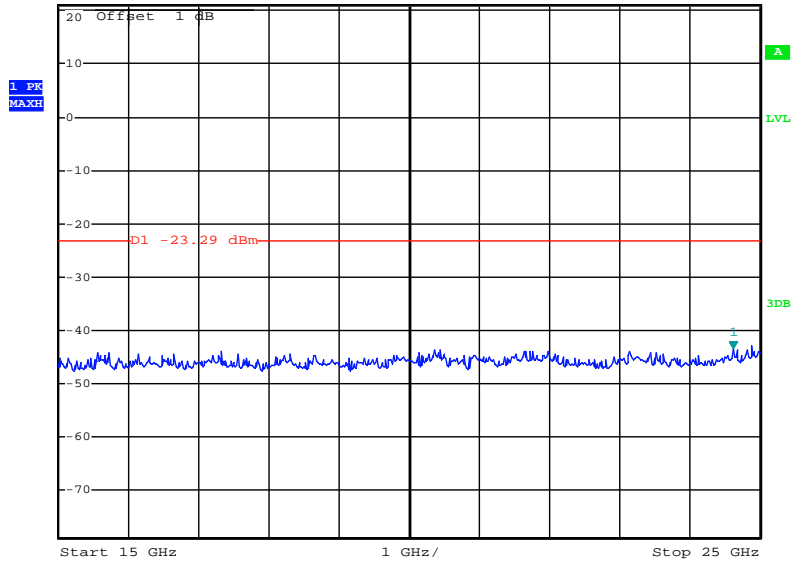

High Channel

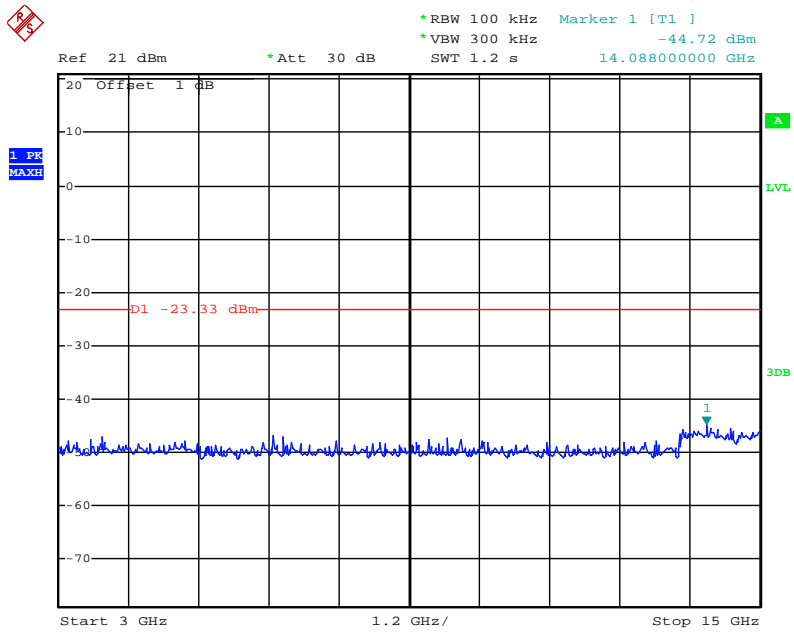
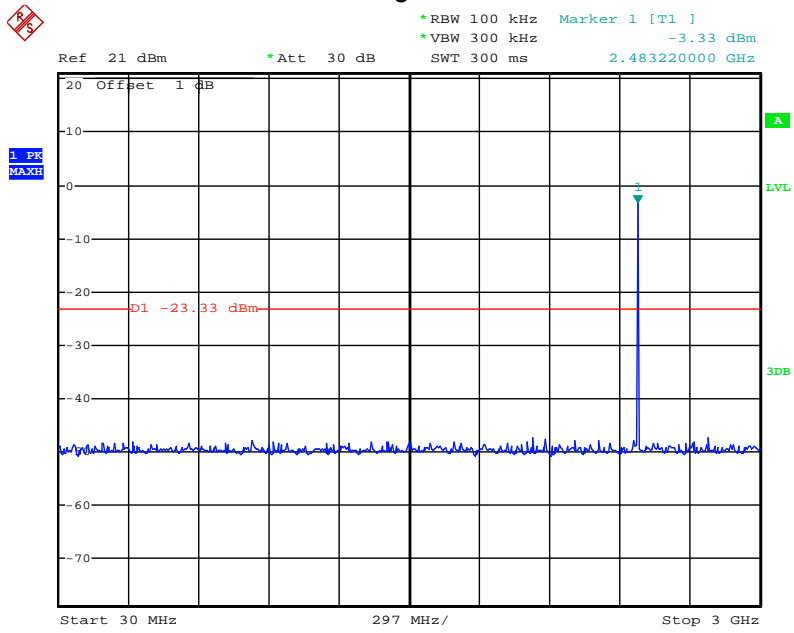



Ref 21 dBm *Att 30 dB *RBW 100 kHz Marker 1 [T1]
*VBW 300 kHz -43.28 dBm
SWT 1 s 15.72000000 GHz

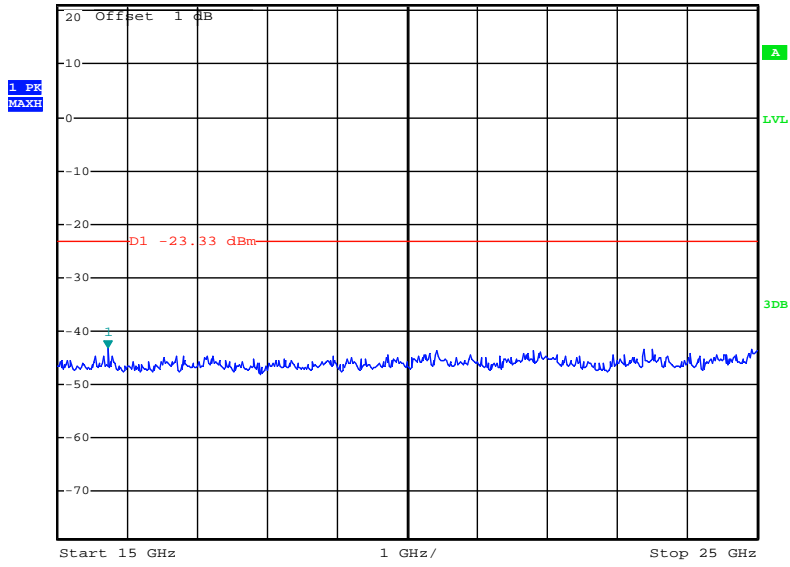

4. POWER SPECTRAL DENSITY TEST

4.1 APPLIED PROCEDURES / LIMIT

FCC Part15 (15.247) , Subpart C&A8.2				
Section	Test Item	Limit	Frequency Range (MHz)	Result
15.247&A8.2	Power Spectral Density	8 dBm (in any 3KHz)	2400-2483.5	PASS

4.1.1 TEST PROCEDURE

1. Set analyzer center frequency to DTS channel center frequency.
2. Set the span to 1.5 times the DTS channel bandwidth.
3. Set the RBW \geq 3 kHz.
4. Set the VBW \geq 3 x RBW.
5. Detector = peak.
6. Sweep time = auto couple.
7. Trace mode = max hold.
8. Allow trace to fully stabilize.
9. Use the peak marker function to determine the maximum amplitude level.
10. If measured value exceeds limit, reduce RBW (no less than 3 kHz) and repeat.

4.1.2 DEVIATION FROM STANDARD

No deviation.

4.1.3 TEST SETUP

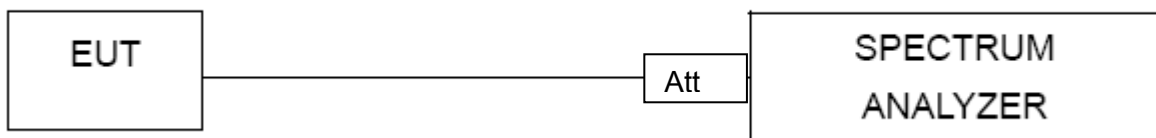

4.1.4 EUT OPERATION CONDITIONS

The EUT tested system was configured as the statements of 2.1 Unless otherwise a special operating condition is specified in the follows during the testing.

4.1.5 TEST RESULTS

EUT :	Bluetooth Speaker	Model Name :	BTS22C
Temperature :	25 °C	Relative Humidity :	56%
Pressure :	1015 hPa	Test Voltage :	DC 3.7V

Channel No.	Frequency (MHz)	Mode	Data Rate	Measured Peak Power Spectral Density (dBm/3KHz)	Limit	Result
0	2402	GFSK	1 Mbps	-20.13	8dBm/3KHz	Pass
19	2440		1 Mbps	-19.86		Pass
39	2480		1 Mbps	-19.75		Pass

Test result: the unit does meet the FCC requirements.

5. BANDWIDTH TEST

5.1 APPLIED PROCEDURES / LIMIT

FCC Part15 (15.247) , Subpart C&A8.2				
Section	Test Item	Limit	Frequency Range (MHz)	Result
15.247(a)(2) &A8.2	Bandwidth	$\geq 500\text{KHz}$ (6dB bandwidth)	2400-2483.5	PASS

5.1.1 TEST PROCEDURE

According to KDB 558074 D01 DTS Meas Guidance v03r02

1. Check the calibration of the measuring instrument using either an internal calibrator or a known signal from an external generator
2. Position the EUT without connection to measurement instrument. Turn on the EUT and connect it to measurement instrument. Then set it to any one convenient frequency within its operating range. Set a reference level on the measuring instrument equal to the highest peak value.
3. Measure the frequency difference of two frequencies that were attenuated 6 dB from the reference level. Record the frequency difference as the emission bandwidth.
4. Repeat above procedures until all frequencies measured were complete.

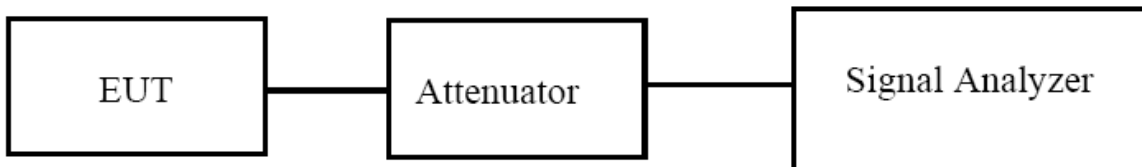

5.1.2 EUT OPERATION CONDITIONS

The EUT tested system was configured as the statements of 2.4 Unless otherwise a special operating condition is specified in the follows during the testing.

5.1.3 TEST RESULTS

EUT :	Bluetooth Speaker	Model Name :	BTS22C
Temperature :	25 °C	Relative Humidity :	56%
Pressure :	1012 hPa	Test Voltage :	DC 3.7V
Test Mode :	TX Mode /CH00, CH19, CH39		

Channel	Frequency (MHz)	6dB bandwidth (kHz)	99% bandwidth (MHz)	Limit (kHz)	Result
Low	2402	750.825	1.2632	>500	Pass
Middle	2440	726.473	1.4483	>500	Pass
High	2480	751.425	1.0439	>500	Pass

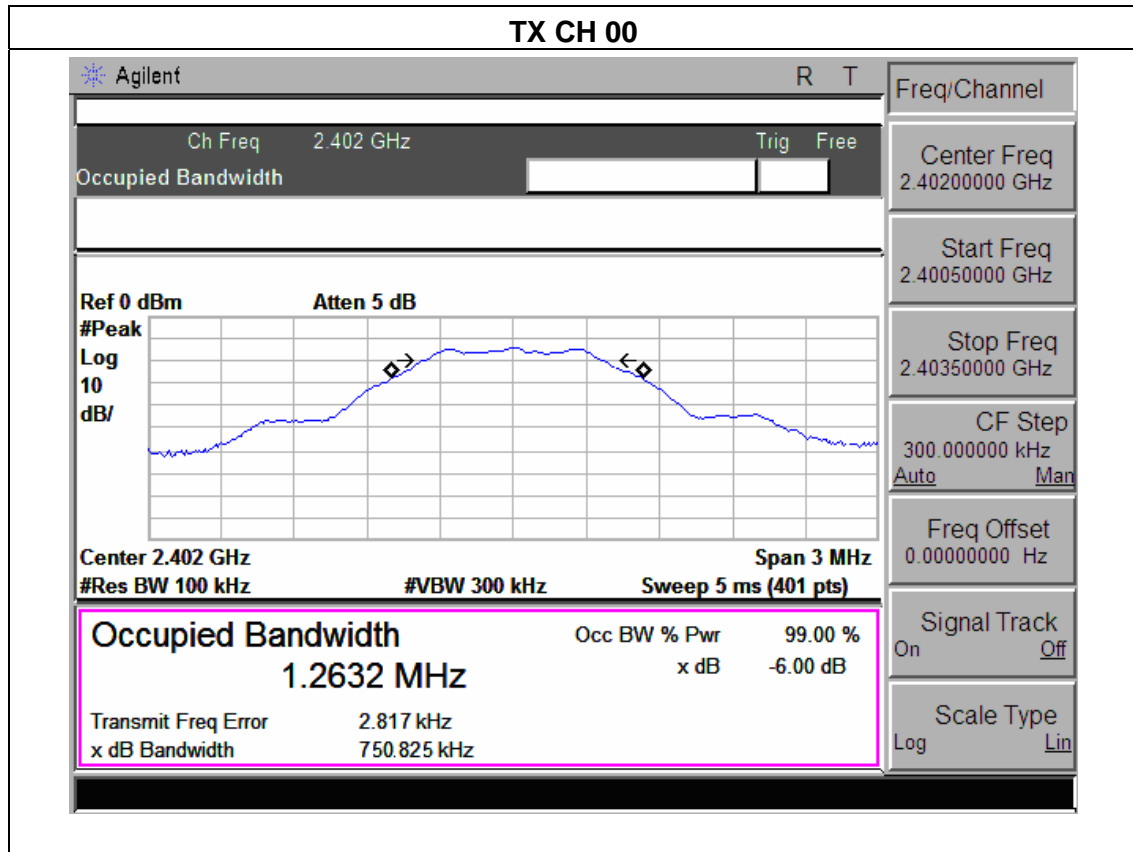

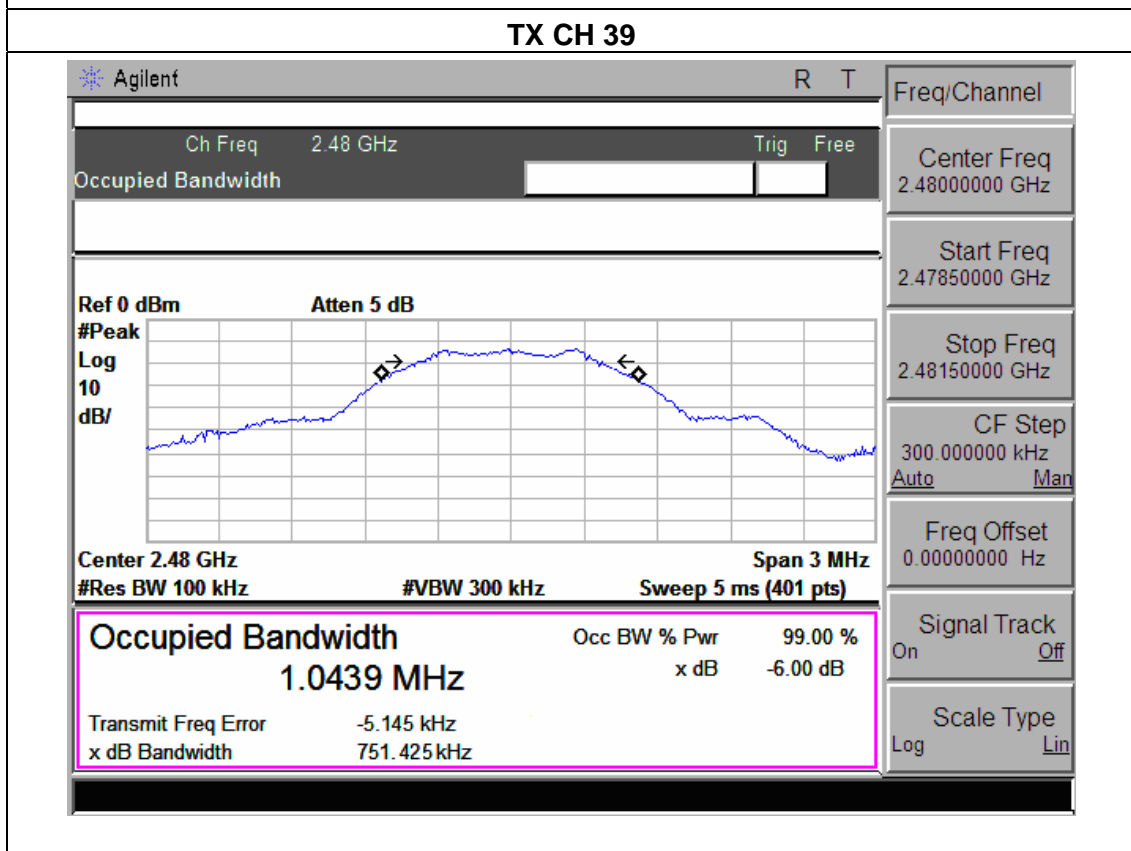
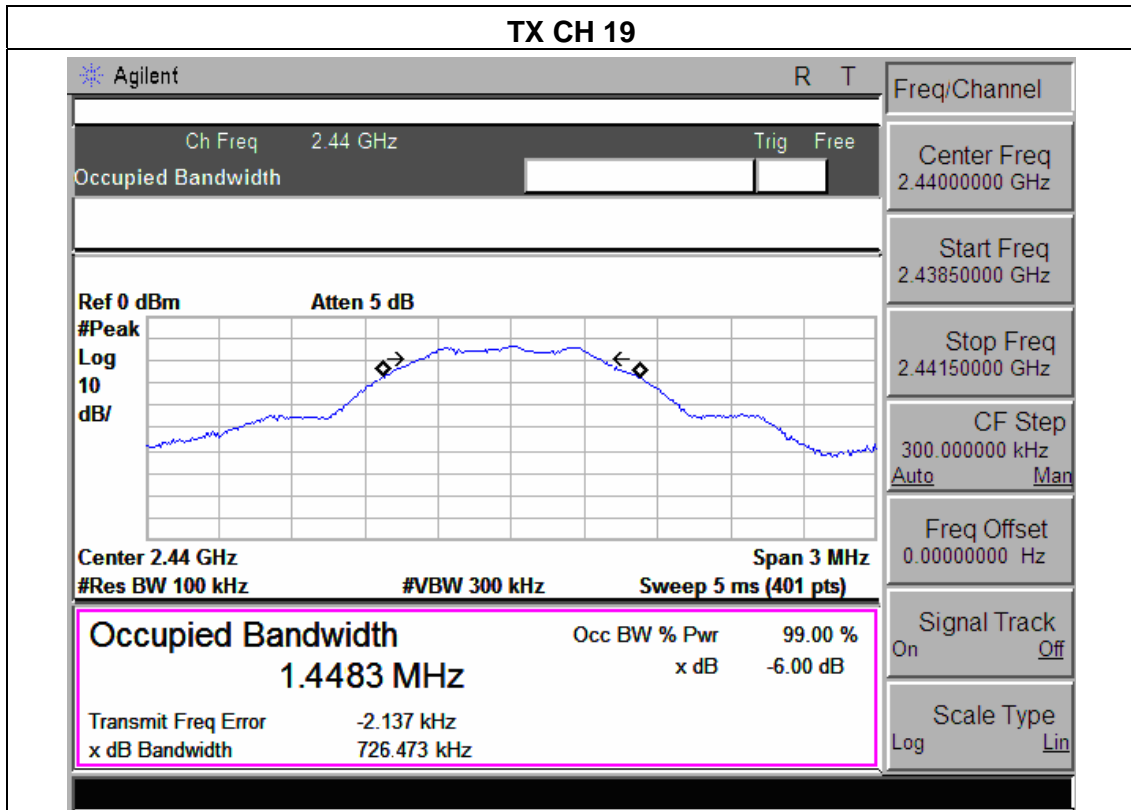

6. PEAK OUTPUT POWER TEST

6.1 APPLIED PROCEDURES / LIMIT

FCC Part15 (15.247) , Subpart C &A8.4				
Section	Test Item	Limit	Frequency Range (MHz)	Result
15.247(b)(3) &A8.4	Peak Output Power	1 watt or 30dBm	2400-2483.5	PASS

6.1.1 TEST PROCEDURE

- a. The EUT was directly connected to the Power meter

6.1.2 DEVIATION FROM STANDARD

No deviation.

6.1.3 TEST SETUP



6.1.4 EUT OPERATION CONDITIONS

The EUT tested system was configured as the statements of 2.4 Unless otherwise a special operating condition is specified in the follows during the testing.

6.1.5 TEST RESULTS

EUT :	Bluetooth Speaker	Model Name :	BTS22C
Temperature :	25 °C	Relative Humidity :	60%
Pressure :	1012 hPa	Test Voltage :	DC 3.7V
Test Mode :	TX Mode		

TX Mode			
Test Channel	Frequency	Maximum Conducted Output Power (PK)	LIMIT
	(MHz)	(dBm)	dBm
CH00	2402	-2.09	30
CH19	2440	-2.25	30
CH39	2480	-2.46	30

7. 100 KHZ BANDWIDTH OF FREQUENCY BAND EDGE APPLICABLE STANDARD

In any 100 kHz bandwidth outside the frequency band in which the spread spectrum or digitally modulated intentional radiator is operating, the radio frequency power that is produced by the intentional radiator shall be at least 20 dB below that in the 100 kHz bandwidth within the band that contains the highest level of the desired power, based on either an RF conducted or a radiated measurement, provided the transmitter demonstrates compliance with the peak conducted power limits. If the transmitter complies with the conducted power limits based on the use of RMS averaging over a time interval, as permitted under paragraph (b)(3) of this section, the attenuation required under this paragraph shall be 30 dB instead of 20 dB. Attenuation below the general limits specified in §15.209(a)&A1.1 is not required. In addition, radiated emissions which fall in the restricted bands, as defined in §15.205(a)&A8.5, must also comply with the radiated emission limits specified in §15.209(a) &A1.1 (see §15.205(c)) &A8.5.

TEST PROCEDURE

- a) Check the calibration of the measuring instrument using either an internal calibrator or a known signal from an external generator.
- b) Position the EUT without connection to measurement instrument. Turn on the EUT and connect its antenna terminal to measurement instrument via a low loss cable. Then set it to any one measured frequency within its operating range, and make sure the instrument is operated in its linear range.
- c) Set RBW to 100 kHz and VBW of spectrum analyzer to 300 kHz with a convenient frequency span including 100 kHz bandwidth from band edge.
- d) Measure the highest amplitude appearing on spectral display and set it as a reference level. Plot the graph with marking the highest point and edge frequency.
- e) Repeat above procedures until all measured frequencies were complete.

7.1 DEVIATION FROM STANDARD

No deviation.

7.2 TEST SETUP

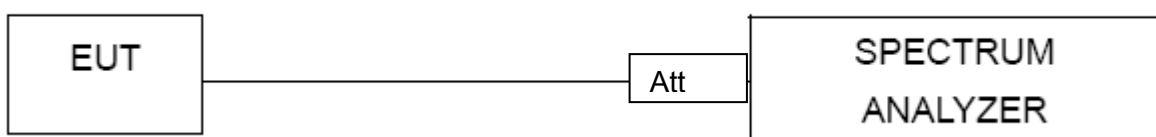

7.3 EUT OPERATION CONDITIONS

The EUT tested system was configured as the statements of 2.4 Unless otherwise a special operating condition is specified in the follows during the testing.

7.4 TEST RESULTS

EUT :	Bluetooth Speaker	Model Name :	BTS22C
Temperature :	25 °C	Relative Humidity :	56%
Pressure :	1012 hPa	Test Voltage :	DC 3.7V

Frequency Band	Delta Peak to band emission (dBc)	> Limit (dBc)	Result
Left-band	46.09	20	Pass
Right-band	48.89	20	Pass

Frequency (MHz)	Meter Reading (dB μ V)	Factor (dB)	Emission Level (dB μ V/m)	Limits (dB μ V/m)	Margin (dB)	Detector Type	Comment
2390	50.32	-13.06	37.26	74	-36.74	peak	Vertical
2390	49.57	-13.06	36.51	74	-37.49	peak	Horizontal
2483.5	48.21	-12.78	35.43	74	-38.57	peak	Vertical
2483.5	49.08	-12.78	36.3	74	-37.70	peak	Horizontal

Note: Test method to see chapter 3.2 . When PK value is lower than the Average value limit, average not record.

Band Edge, Left Side

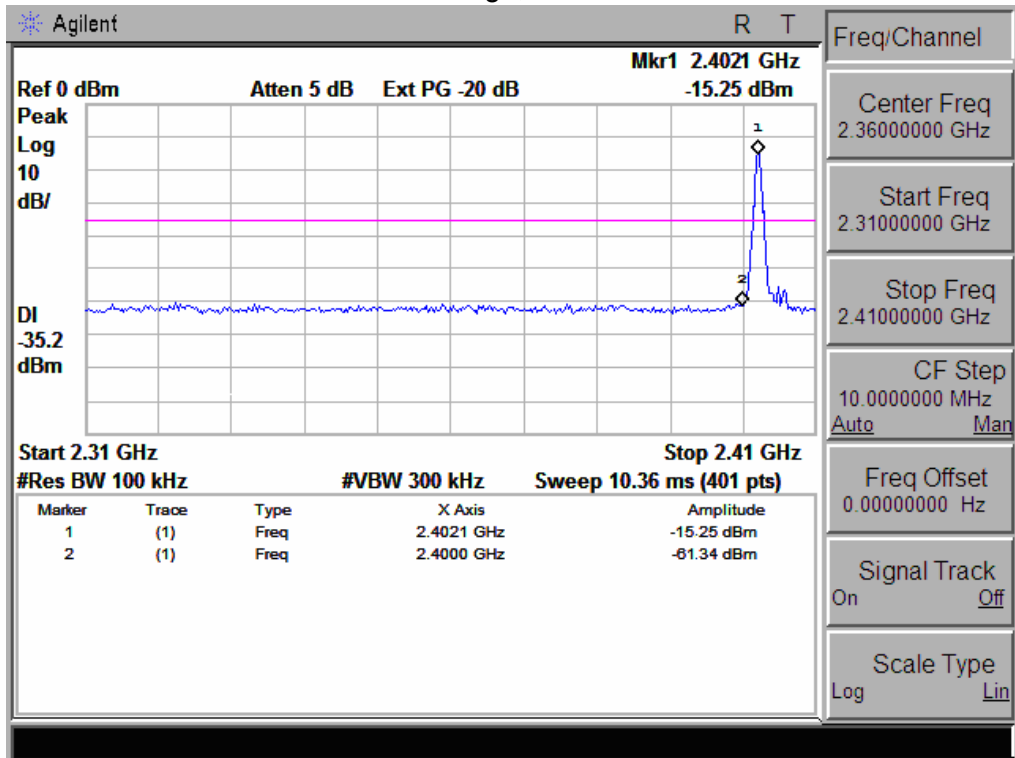

Band Edge, Right Side

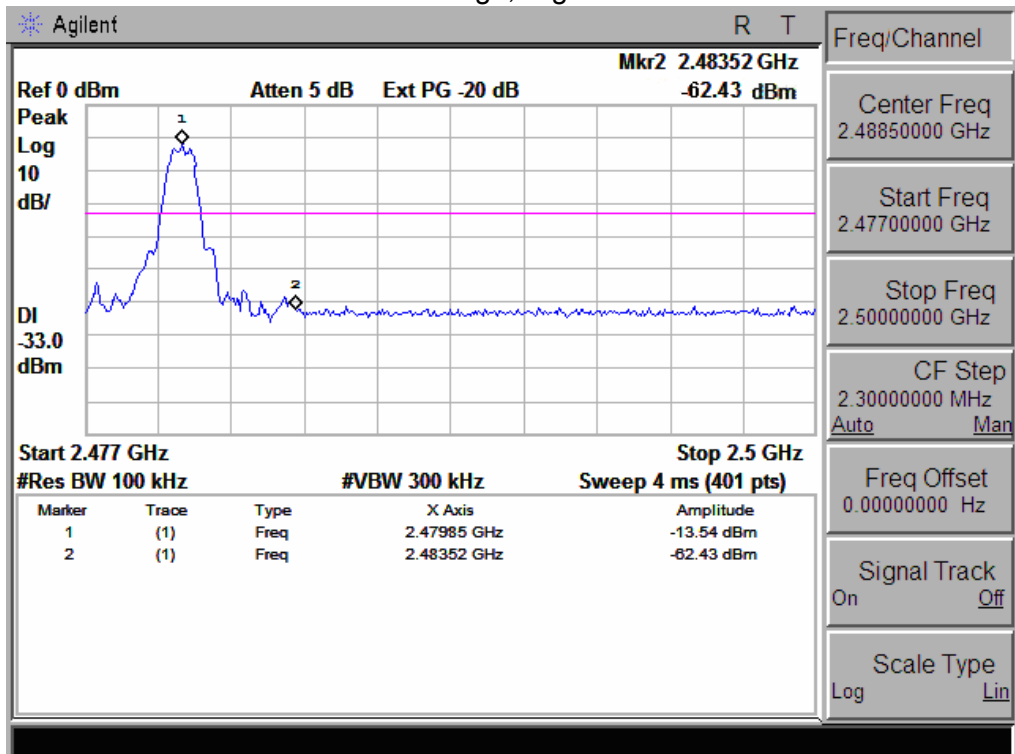

8. ANTENNA REQUIREMENT

8.1 STANDARD REQUIREMENT

15.203 requirement: For intentional device, according to 15.203: an intentional radiator shall be designed to ensure that no antenna other than that furnished by the responsible party shall be used with the device.

8.2 EUT ANTENNA

The EUT antenna is Built-in antenna. It comply with the standard requirement.

9. EUT TEST PHOTO

Radiated Measurement Photos

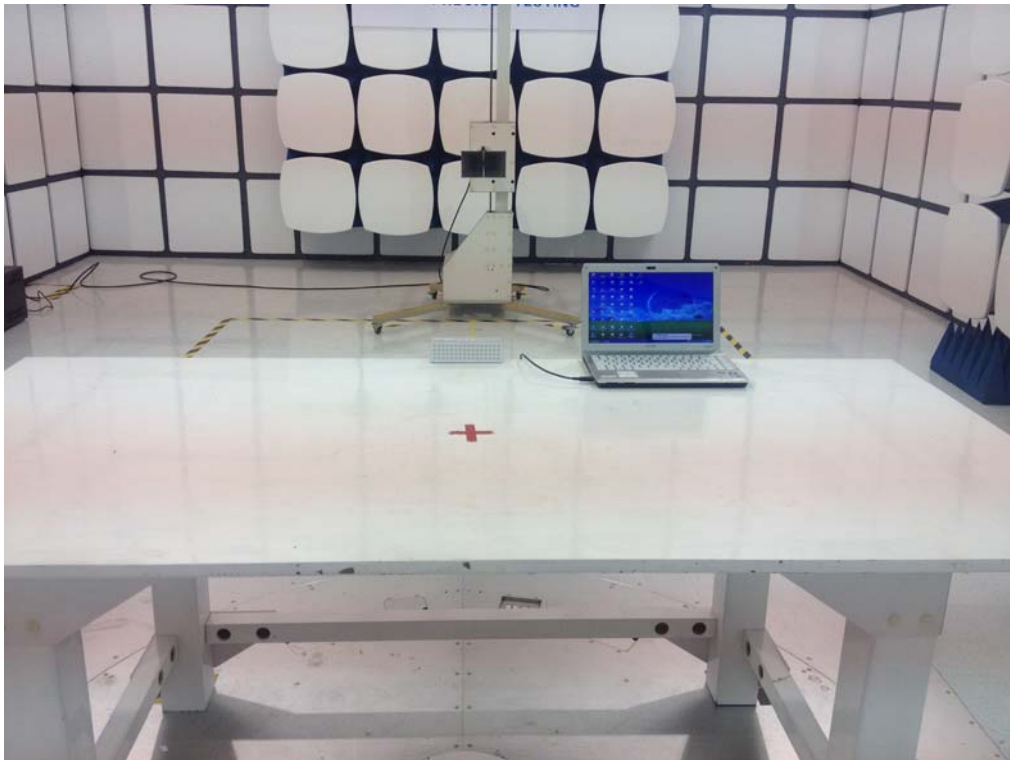
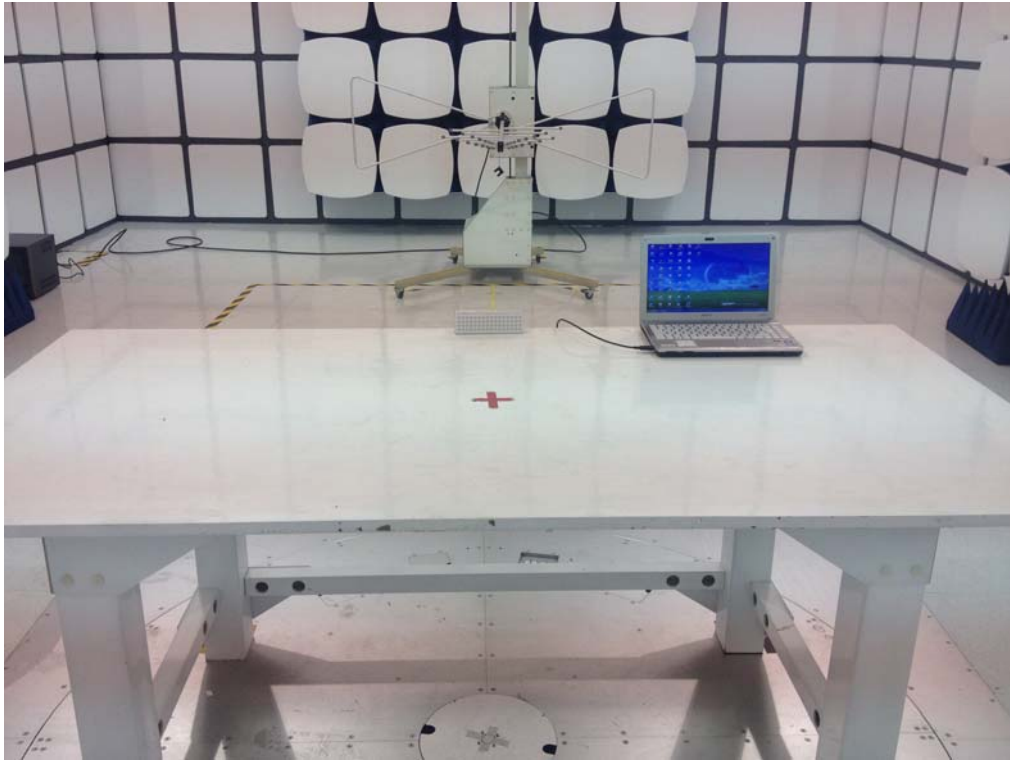

Conducted Measurement Photos

