

# FCC RF Test Report

APPLICANT : Enda Gormley Sile LLC  
EQUIPMENT : HDMI Digital Media Receiver  
MODEL NAME : W87CUN  
FCC ID : 2ABDU-0509  
STANDARD : FCC Part 15 Subpart E §15.407  
CLASSIFICATION : (NII) Unlicensed National Information Infrastructure

The testing completed on Jul. 13, 2014. We, SPORTON INTERNATIONAL INC., would like to declare that the tested sample has been evaluated in accordance with the test procedures and has been in compliance with the applicable technical standards.

The test results in this report apply exclusively to the tested model / sample. Without written approval of SPORTON INTERNATIONAL INC., the test report shall not be reproduced except in full.



Reviewed by: Joseph Lin / Supervisor

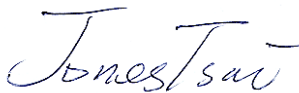

Approved by: Jones Tsai / Manager



**SPORTON INTERNATIONAL INC.**

No. 52, Hwa Ya 1<sup>st</sup> Rd., Hwa Ya Technology Park, Kwei-Shan Hsiang, Tao Yuan Hsien, Taiwan, R.O.C.

Report No. : FR441920-02D

Report Version : Rev. 01

Page Number : 1 of 55

Report Template No.: BU5-FR15EWL Version 1.0

# TABLE OF CONTENTS

REVISION HISTORY.....	3
SUMMARY OF TEST RESULT .....	4
<b>1 GENERAL DESCRIPTION .....</b>	<b>5</b>
1.1 Applicant.....	5
1.2 Feature of Equipment Under Test .....	5
1.3 Product Specification of Equipment Under Test.....	6
1.4 Modification of EUT .....	6
1.5 Testing Location .....	7
1.6 Applicable Standards.....	7
<b>2 TEST CONFIGURATION OF EQUIPMENT UNDER TEST.....</b>	<b>8</b>
2.1 Carrier Frequency and Channel .....	8
2.2 Pre-Scanned RF Power.....	9
2.3 Test Mode.....	10
2.4 Connection Diagram of Test System.....	11
2.5 Support Unit used in test configuration and system .....	12
2.6 EUT Operation Test Setup .....	13
2.7 Measurement Results Explanation Example.....	13
<b>3 TEST RESULT.....</b>	<b>14</b>
3.1 6dB Bandwidth Measurement .....	14
3.2 Maximum Conducted Output Power Measurement .....	16
3.3 Power Spectral Density Measurement .....	18
3.4 Unwanted Emissions Measurement.....	21
3.5 AC Conducted Emission Measurement.....	44
3.6 Frequency Stability Measurement.....	49
3.7 Automatically Discontinue Transmission .....	51
3.8 Antenna Requirements.....	52
<b>4 LIST OF MEASURING EQUIPMENT.....</b>	<b>54</b>
<b>5 UNCERTAINTY OF EVALUATION.....</b>	<b>55</b>

## REVISION HISTORY

REPORT NO.	VERSION	DESCRIPTION	ISSUED DATE
FR441920-02D	Rev. 01	Initial issue of report	Aug. 06, 2014

## SUMMARY OF TEST RESULT

Report Section	FCC Rule	Description	Limit	Result	Remark
3.1	15.403(i)	6dB Bandwidth	> 500kHz	Pass	-
3.2	15.407(a)	Maximum Conducted Output Power	≤ 30 dBm	Pass	-
3.3	15.407(a)	Power Spectral Density	≤ 30 dBm/500kHz	Pass	-
3.4	15.407(b)	Unwanted Emissions	≤ -17, -27 dBm/MHz & 15.209(a)	Pass	Under limit 0.51 dB at 5724.840 MHz and 5861.840MHz
3.5	15.207	AC Conducted Emission	15.207(a)	Pass	Under limit 3.50 dB at 0.510 MHz
3.6	15.407(g)	Frequency Stability	Within Operation Band	Pass	-
3.7	15.407(c)	Automatically Discontinue Transmission	Discontinue Transmission	Pass	-
3.8	15.203 & 15.407(a)	Antenna Requirement	N/A	Pass	-

# 1 General Description

## 1.1 Applicant

**Enda Gormley Sile LLC**  
Debbie Maynerich  
11670 Fountains Drive  
Suite 200  
Maple Grove, Minnesota, 55369

## 1.2 Feature of Equipment Under Test

Product Feature	
<b>Equipment</b>	HDMI Digital Media Receiver
<b>Model Name</b>	W87CUN
<b>FCC ID</b>	2ABDU-0509
<b>EUT supports Radios application</b>	WLAN 11b/g/n HT20 WLAN 11a/n HT20/HT40 Bluetooth v3.0 BR/EDR

**Remark:** The above EUT's information was declared by manufacturer. Please refer to the specifications or user's manual for more detailed description.

### 1.3 Product Specification of Equipment Under Test

Product Specification subjective to this standard										
<b>Tx/Rx Channel Frequency Range</b>	5745 MHz ~ 5825 MHz									
<b>Maximum Output Power</b>	<b>&lt;Ant. 1&gt;</b> 802.11a : 16.36 dBm / 0.0433 W <b>&lt;Ant. 2&gt;</b> 802.11a : 15.97 dBm / 0.0395 W <b>MIMO &lt;Ant. 1 + 2&gt;</b> 802.11n HT20 : 19.05 dBm / 0.0804 W 802.11n HT40 : 18.12 dBm / 0.0649 W									
<b>Type of Modulation</b>	802.11a/n : OFDM (BPSK / QPSK / 16QAM / 64QAM)									
<b>Antenna Type</b>	<b>Ant. 1</b> : PCB printing Antenna with gain 4.40 dBi <b>Ant. 2</b> : PCB printing Antenna with gain 7.20 dBi									
<b>Antenna Function Description</b>	<table border="1"> <thead> <tr> <th></th> <th>Chain Port 0 Ant. 1</th> <th>Chain Port 1 Ant. 2</th> </tr> </thead> <tbody> <tr> <td>802.11 a</td> <td>V</td> <td>V</td> </tr> <tr> <td>802.11 n MIMO</td> <td>V</td> <td>V</td> </tr> </tbody> </table>		Chain Port 0 Ant. 1	Chain Port 1 Ant. 2	802.11 a	V	V	802.11 n MIMO	V	V
	Chain Port 0 Ant. 1	Chain Port 1 Ant. 2								
802.11 a	V	V								
802.11 n MIMO	V	V								

### 1.4 Modification of EUT

No modifications are made to the EUT during all test items.

## 1.5 Testing Location

Sporton Lab is accredited to ISO 17025 by Taiwan Accreditation Foundation (TAF code : 1190) and the FCC designation No. TW1022 under the FCC 2.948(e) by Mutual Recognition Agreement (MRA) in FCC Test.

<b>Test Site</b>	SPORTON INTERNATIONAL INC.		
<b>Test Site Location</b>	No. 52, Hwa Ya 1 <sup>st</sup> Rd., Hwa Ya Technology Park, Kwei-Shan Hsiang, Tao Yuan Hsien, Taiwan, R.O.C. TEL: +886-3-327-3456 FAX: +886-3-328-4978		
<b>Test Site No.</b>	<b>Sporton Site No.</b>		
	TH02-HY	CO05-HY	03CH07-HY

## 1.6 Applicable Standards

According to the specifications of the manufacturer, the EUT must comply with the requirements of the following standards:

- ♦ FCC Part 15 Subpart E
- ♦ FCC KDB 789033 D02 General UNII Test Procedures New Rules v01
- ♦ FCC KDB 662911 D01 Multiple Transmitter Output v02r01.
- ♦ ANSI C63.4-2003

### Remark:

1. All test items were verified and recorded according to the standards and without any deviation during the test.
2. This EUT has also been tested and complied with the requirements of FCC Part 15, Subpart B, recorded in a separate test report.

## 2 Test Configuration of Equipment Under Test

The EUT has been associated with peripherals and configuration operated in a manner tended to maximize its emission characteristics in a typical application. Frequency range investigated: conducted emission (150 kHz to 30 MHz) and radiated emission (9 kHz to the 10th harmonic of the highest fundamental frequency or to 40 GHz, whichever is lower). For radiated measurement, pre-scanned in three orthogonal panels, X, Y, Z. The worst cases (X plane) were recorded in this report.

The final configuration from all the combinations and the worst-case data rates were investigated by measuring the maximum power across all the data rates and modulation modes under section 2.2.

Based on the worst configuration found above, the RF power setting is set individually to meet FCC compliance limit for the final conducted and radiated tests shown in section 2.3.

### 2.1 Carrier Frequency and Channel

Frequency Band	Channel	Freq. (MHz)	Channel	Freq. (MHz)
5725-5850 MHz Band 4 (U-NII-3)	149	5745	157	5785
	<b>151</b>	<b>5755</b>	<b>159</b>	<b>5795</b>
	153	5765	161	5805
	155	5775	165	5825

**Note:** The above Frequency and Channel in boldface were 802.11n HT40.



## 2.2 Pre-Scanned RF Power

Preliminary tests were performed in different data rate and data rate associated with the highest power were chosen for full test in the following tables.

<Ant. 1>

5GHz 802.11a mode								
Data Rate (MHz)	6M bps	9M bps	12M bps	18M bps	24M bps	36M bps	48M bps	54M bps
Average Power (dBm)	16.36	16.17	16.25	16.33	16.32	16.32	16.21	16.21

<Ant. 2>

5GHz 802.11a mode								
Data Rate (MHz)	6M bps	9M bps	12M bps	18M bps	24M bps	36M bps	48M bps	54M bps
Average Power (dBm)	15.97	15.93	15.96	15.86	15.96	15.94	15.96	15.90

MIMO <Ant. 1 + 2>

5GHz 802.11n HT20 mode								
Data Rate (MHz)	MCS 0	MCS 1	MCS 2	MCS 3	MCS 4	MCS 5	MCS 6	MCS 7
Average Power (dBm)	19.05	19.04	19.00	19.00	18.96	19.01	18.98	18.98
Data Rate (MHz)	MCS 8	MCS 9	MCS 10	MCS 11	MCS 12	MCS 13	MCS 14	MCS 15
Average Power (dBm)	19.03	19.02	19.02	19.03	18.99	19.02	19.02	18.96

5GHz 802.11n HT40 mode								
Data Rate (MHz)	MCS 0	MCS 1	MCS 2	MCS 3	MCS 4	MCS 5	MCS 6	MCS 7
Average Power (dBm)	18.12	18.09	18.05	18.05	18.02	17.98	17.95	17.93
Data Rate (MHz)	MCS 8	MCS 9	MCS 10	MCS 11	MCS 12	MCS 13	MCS 14	MCS 15
Average Power (dBm)	18.03	17.97	17.92	17.95	18.03	18.04	18.00	17.92

**Note:** MIMO Ant. 1+2 is a calculated result from sum of the power MIMO Ant. 1 and MIMO Ant. 2.

## 2.3 Test Mode

Final results of test modes, data rates and test channels are shown as following table.

Test Cases				
Conducted TCs	Test Items	Mode	Data rate	Test Channel
	6dB Bandwidth Power Spectral Density	802.11a	6 Mbps	L/M/H
		802.11n HT20	MCS0	L/M/H
		802.11n HT40	MCS0	L/M/H
	Output Power	802.11a	6 Mbps	L/M/H
		802.11n HT20	MCS0	L/M/H
		802.11n HT40	MCS0	L/M/H
Frequency Stability	802.11a	6 Mbps	L	
Radiated TCs	Test Items	Mode	Data rate	Test Channel
	Radiated Band Edge	802.11a	6 Mbps	L/H
		802.11n HT20	MCS0	L/H
		802.11n HT40	MCS0	L/H
	Radiated Spurious Emission	802.11a	6 Mbps	L/M/H
		802.11n HT20	MCS0	L/M/H
802.11n HT40		MCS0	L/M/H	
AC Conducted Emission	Mode 1 : WLAN (5GHz) Link + Bluetooth Link + Buttercup + MPEG4 + USB Cable (Charging from Adapter) <Fig. 1>			
	Mode 2 : WLAN (5GHz) Link + Buttercup + MPEG4 + USB Cable (Charging from Adapter) <Fig. 2>			
<b>Remark:</b> The worst case of conducted emission is mode 1; only the test data of it was reported.				

Ch. #	Band IV : 5725-5850 MHz			
	802.11a	802.11n HT20	802.11n HT40	
L	Low	149	149	151
M	Middle	157	157	-
H	High	165	165	159

## 2.4 Connection Diagram of Test System

<WLAN Tx Mode>

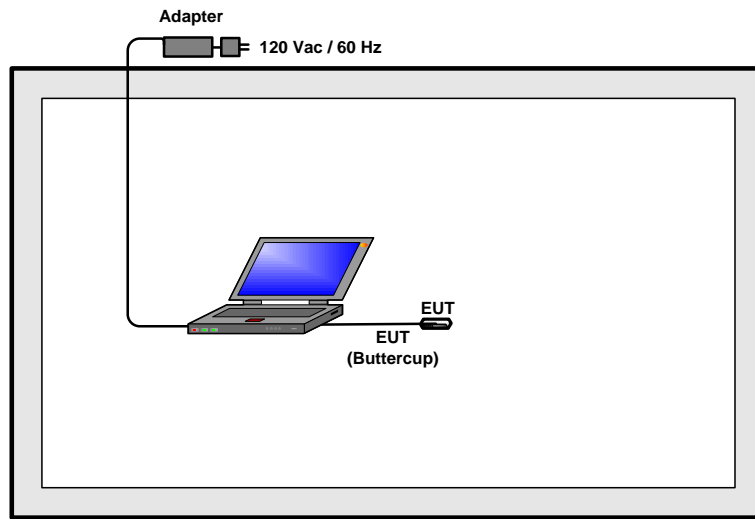

<AC Conducted Emission with Bluetooth Remote Controller Mode>

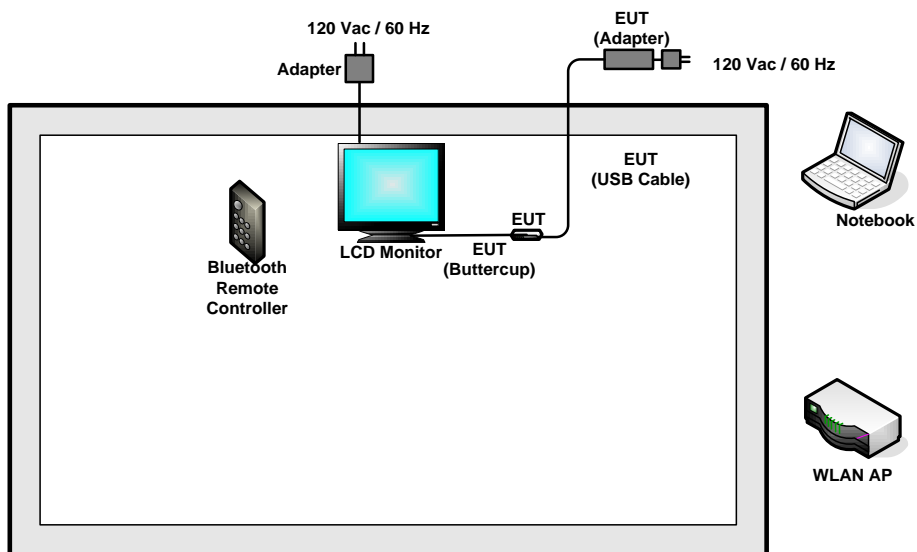

<Fig. 1>

< AC Conducted Emission Mode >

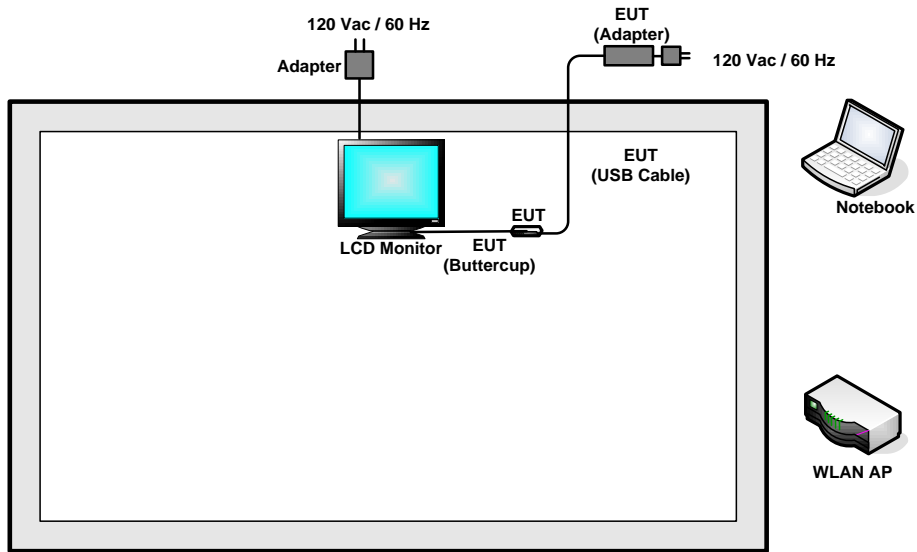

<Fig. 2>

## 2.5 Support Unit used in test configuration and system

Item	Equipment	Trade Name	Model Name	FCC ID	Data Cable	Power Cord
1.	WLAN AP	D-Link	DIR-628	KA2DIR628A2	N/A	Unshielded, 1.8 m
2.	LCD Monitor	DELL	U2410	FCC DoC	Shielded, 1.6 m	Unshielded, 1.8 m
3.	Bluetooth Remote Controller	N/A	CV98LM	2ABDV-0929	N/A	N/A
4.	Notebook	DELL	Vostro 1510	FCC DoC/ Contains FCC ID: E2K4965AGNM	N/A	AC I/P: Unshielded, 1.2 m DC O/P: Shielded, 1.8 m
5.	Notebook	DELL	Latitude E6320	FCC DoC/ Contains FCC ID: QDS-BRCM1054	N/A	AC I/P: Unshielded, 1.2 m DC O/P: Shielded, 1.8 m

## 2.6 EUT Operation Test Setup

For WLAN function, programmed RF utility, “ADB” installed in the notebook make the EUT provide functions like channel selection and power level for continuous transmitting and receiving signals.

## 2.7 Measurement Results Explanation Example

**For all conducted test items:**

The offset level is set in the spectrum analyzer to compensate the RF cable loss and attenuator factor between EUT conducted output port and spectrum analyzer. With the offset compensation, the spectrum analyzer reading level is exactly the EUT RF output level.

Example :

The spectrum analyzer offset is derived from RF cable loss and attenuator factor.

*Offset = RF cable loss + attenuator factor.*

Following shows an offset computation example with cable loss 4.2 dB and 10dB attenuator.

$$\begin{aligned} \text{Offset(dB)} &= \text{RF cable loss(dB)} + \text{attenuator factor(dB)}. \\ &= 4.2 + 10 = 14.2 \text{ (dB)} \end{aligned}$$

## 3 Test Result

### 3.1 6dB Bandwidth Measurement

#### 3.1.1 Description of 6dB Bandwidth

This section is for reporting purpose only.

There is no restriction limits for bandwidth.

#### 3.1.2 Measuring Instruments

The measuring equipment is listed in the section 4 of this test report.

#### 3.1.3 Test Procedures

1. The testing follows FCC KDB 789033 D02 General UNII Test Procedures New Rules v01.  
Section C) Emission bandwidth for the band 5.725-5.85GHz
2. Set RBW = 100kHz.
3. Set the VBW  $\geq 3 \times$  RBW.
4. Detector = Peak.
5. Trace mode = max hold
6. Measure the maximum width of the emission that is 6 dB down from the peak of the emission.
7. Measure and record the results in the test report.

#### 3.1.4 Test Setup

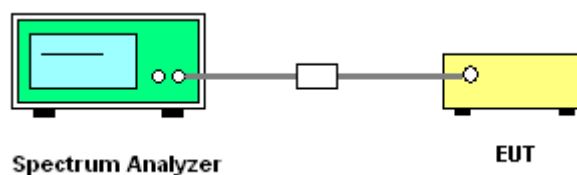

### 3.1.5 Test Result of 6dB Bandwidth

Test Band :	5GHz band IV	Temperature :	21~26°C
Test Engineer :	Stuart Lin	Relative Humidity :	45~54%

Mod.	Data Rate	NTX	Channel	Freq. (MHz)	6 dB Bandwidth (MHz)		FCC 6 dB Bandwidth Min. Limit (MHz)		Pass/Fail
					Ant 1	Ant 2	Ant 1	Ant 2	
11a	6Mbps	1	149	5745	15.62	-	0.5	0.5	Pass
11a	6Mbps	1	157	5785	15.48	-	0.5	0.5	Pass
11a	6Mbps	1	165	5825	15.48	-	0.5	0.5	Pass
HT20	MCS0	2	149	5745	15.76	16.32	0.5	0.5	Pass
HT20	MCS0	2	157	5785	15.10	16.32	0.5	0.5	Pass
HT20	MCS0	2	165	5825	15.78	16.34	0.5	0.5	Pass
HT40	MCS0	2	151	5755	35.68	36.30	0.5	0.5	Pass
HT40	MCS0	2	159	5795	35.12	35.68	0.5	0.5	Pass

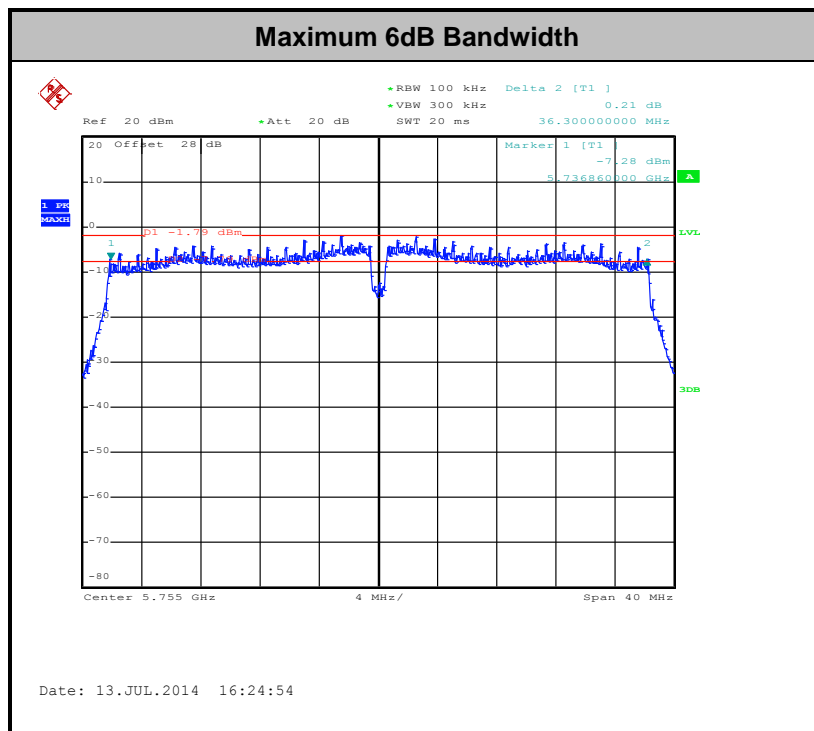

**Note:** The occupied channel bandwidth is maintained within the band of operation for all of the modulations.

## 3.2 Maximum Conducted Output Power Measurement

### 3.2.1 Limit of Maximum Conducted Output Power

#### <FCC 14-30 CFR 15.407>

For the band 5.725–5.85 GHz, the maximum conducted output power over the frequency band of operation shall not exceed 1 W.

If transmitting antennas of directional gain greater than 6 dBi are used, the peak output power shall be reduced by the amount in dB that the directional gain of the antenna exceeds 6 dBi.

### 3.2.2 Measuring Instruments

The measuring equipment is listed in the section 4 of this test report.

### 3.2.3 Test Procedures

The testing follows Method PM of FCC KDB 789033 D02 General UNII Test Procedures New Rules v01.

Method PM (Measurement using an RF average power meter):

1. Measurement is performed using a wideband RF power meter.
2. The EUT is configured to transmit continuously with a consistent duty cycle at its maximum power control level.
3. Measure the average power of the transmitter, and the average power is corrected with duty factor,  $10 \log(1/x)$ , where  $x$  is the duty cycle.

### 3.2.4 Test Setup

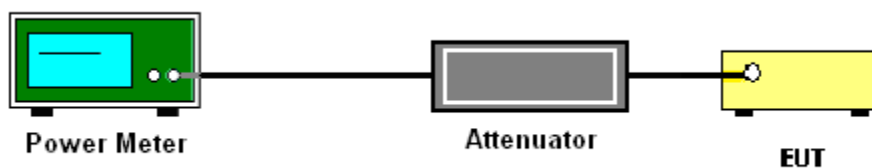



### 3.2.5 Test Result of Maximum Conducted Output Power

<b>Test Band :</b>	5GHz band IV	<b>Temperature :</b>	21~26°C
<b>Test Engineer :</b>	Stuart Lin	<b>Relative Humidity :</b>	45~54%

Mod.	Data Rate	NTX	Channel	Freq. (MHz)	Duty Factor (dB)		Average Conducted Power (dBm)			FCC Conducted Power Limit (dBm)		DG (dBi)		Pass /Fail
					Ant 1	Ant 2	Ant 1	Ant 2	SUM	Ant 1	Ant 2	Ant 1	Ant 2	
11a	6Mbps	1	149	5745	0.23	0.23	15.88	15.97	-	30.00	28.80	4.40	7.20	Pass
11a	6Mbps	1	157	5785	0.23	0.23	16.36	15.93		30.00	28.80	4.40	7.20	Pass
11a	6Mbps	1	165	5825	0.23	0.23	16.35	15.86		30.00	28.80	4.40	7.20	Pass
HT20	MCS0	2	149	5745	0.22	0.20	12.38	13.12	15.78	27.08		8.92		Pass
HT20	MCS0	2	157	5785	0.22	0.20	15.74	16.31	19.05	27.08		8.92		Pass
HT20	MCS0	2	165	5825	0.22	0.20	14.14	14.81	17.50	27.08		8.92		Pass
HT40	MCS0	2	151	5755	0.44	0.44	8.93	9.91	12.46	27.08		8.92		Pass
HT40	MCS0	2	159	5795	0.44	0.44	14.78	15.41	18.12	27.08		8.92		Pass

## 3.3 Power Spectral Density Measurement

### 3.3.1 Limit of Power Spectral Density

#### <FCC 14-30 CFR 15.407>

For the band 5.725–5.85 GHz, the maximum power spectral density shall not exceed 30 dBm in any 500-kHz band.

If transmitting antennas of directional gain greater than 6 dBi are used, the peak output power shall be reduced by the amount in dB that the directional gain of the antenna exceeds 6 dBi.

### 3.3.2 Measuring Instruments

The measuring equipment is listed in the section 4 of this test report.

### 3.3.3 Test Procedures

The testing follows FCC KDB 789033 D02 General UNII Test Procedures New Rules v01. Section F) Maximum power spectral density.

#### **# Method SA-2 #**

(trace averaging across on and off times of the EUT transmissions, followed by duty cycle correction).

1. The testing follows Method SA-2 of FCC KDB 789033 D01 General UNII Test Procedures v01r03.
  - Measure the duty cycle.
  - Set span to encompass the entire emission bandwidth (EBW) of the signal.
  - Set RBW = 300 kHz.
  - Set VBW  $\geq$  1 MHz.
  - Number of points in sweep  $\geq$  2 Span / RBW.
  - Sweep time = auto.
  - Detector = RMS
  - Trace average at least 100 traces in power averaging mode.
  - Add  $10 \log(500\text{kHz}/\text{RBW})$  to the test result.
  - Add  $10 \log(1/x)$ , where  $x$  is the duty cycle, to the measured power in order to compute the average power during the actual transmission times. For example, add  $10 \log(1/0.25) = 6$  dB if the duty cycle is 25 percent.

2. The RF output of EUT was connected to the spectrum analyzer by a low loss cable.
3. Each plot has already offset with cable loss, and attenuator loss. Measure the PPSD and record it.
4. For MIMO mode, calculation method follows FCC KDB 662911 D01 Multiple Transmitter Output v02r01.

Method (1): Measure and sum the spectra across the outputs.

The total final Power Spectral Density is from a device with 2 transmitter outputs. The spectrum measurements of the individual outputs are all performed with the same span and number of points, the spectrum value in the first spectral bin of output 1 is summed with that in the first spectral bin of output 2 to obtain the value for the first frequency bin of the summed spectrum.

### 3.3.4 Test Setup

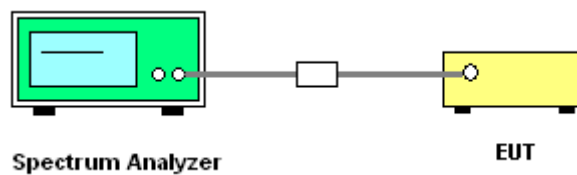

### 3.3.5 Test Result of Power Spectral Density

<b>Test Band :</b>	5GHz band IV	<b>Temperature :</b>	21~26°C
<b>Test Engineer :</b>	Stuart Lin	<b>Relative Humidity :</b>	45~54%

Mod.	Data Rate	NTX	Channel	Freq. (MHz)	Duty Factor (dB)		10log (500kHz /RBW) Factor (dB)		Average Power Density (dBm/500kHz)			Average PSD Limit (dBm/500kHz)		DG (dBi)		Pass /Fail
					Ant 1	Ant 2	Ant 1	Ant 2	Ant 1	Ant 2	SUM	Ant 1	Ant 2	Ant 1	Ant 2	
11a	6Mbps	1	149	5745	0.23	0.23	2.22	2.22	3.41	-	-	30.00	28.80	4.40	7.20	Pass
11a	6Mbps	1	157	5785	0.23	0.23	2.22	2.22	4.06	-	-	30.00	28.80	4.40	7.20	Pass
11a	6Mbps	1	165	5825	0.23	0.23	2.22	2.22	3.79	-	-	30.00	28.80	4.40	7.20	Pass
HT20	MCS0	2	149	5745	0.22	0.20	2.22	2.22	-			3.20	27.08	8.92	Pass	
HT20	MCS0	2	157	5785	0.22	0.20	2.22	2.22				6.28	27.08	8.92	Pass	
HT20	MCS0	2	165	5825	0.22	0.20	2.22	2.22				4.74	27.08	8.92	Pass	
HT40	MCS0	2	151	5755	0.44	0.44	2.22	2.22				-2.37	27.08	8.92	Pass	
HT40	MCS0	2	159	5795	0.44	0.44	2.22	2.22				3.19	27.08	8.92	Pass	

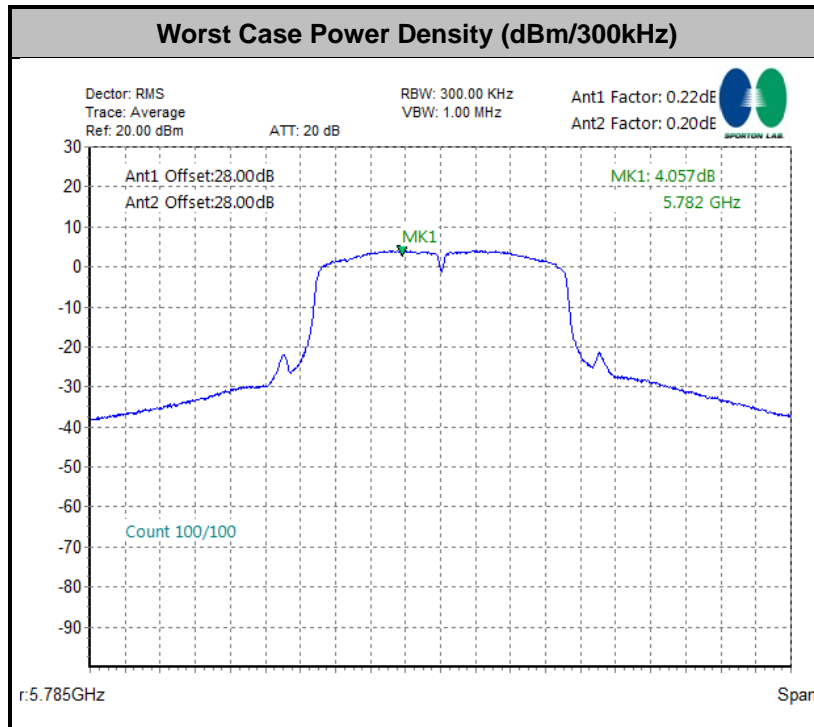

### 3.4 Unwanted Emissions Measurement

This section as specified in FCC Part 15.407(b) is to measure unwanted emissions through radiated measurement for band edge spurious emissions and out of band emissions measurement. The unwanted emissions shall comply with 15.407(b)(1) to (6), and restricted bands per FCC Part15.205.

#### 3.4.1 Limit of Unwanted Emissions

- (1) For transmitters operating in the 5725-5850 MHz band: all emissions within the frequency range from the band edge to 10 MHz above or below the band edge shall not exceed an EIRP of -17 dBm/MHz (78.3dBµV/m); for frequencies 10 MHz or greater above or below the band edge, emissions shall not exceed an EIRP of -27 dBm/MHz (68.3dBµV/m).
- (2) Unwanted spurious emissions fallen in restricted bands per FCC Part15.205 shall comply with the general field strength limits set forth in § 15.209 as below table,

Frequency (MHz)	Field Strength (microvolts/meter)	Measurement Distance (meters)
0.009 – 0.490	2400/F(kHz)	300
0.490 – 1.705	24000/F(kHz)	30
1.705 – 30.0	30	30
30 – 88	100	3
88 – 216	150	3
216 - 960	200	3
Above 960	500	3

**Note:** The following formula is used to convert the EIRP to field strength.

$$E = \frac{1000000\sqrt{30P}}{3} \mu\text{V/m, where P is the eirp (Watts)}$$

EIRP (dBm)	Field Strength at 3m (dBµV/m)
-17	78.3
- 27	68.3

- (3) KDB789033 v01r03 H)2)c)(i) As specified in 15.407(b), emissions above 1000 MHz that are outside of the restricted bands are subject to a peak emission limit of -27 dBm/MHz (or -17 dBm/MHz as specified in 15.407(b)(4)). However, an out-of-band emission that complies with both the average and peak limits of 15.209 is not required to satisfy the -27 dBm/MHz or -17 dBm/MHz peak emission limit.

### 3.4.2 Measuring Instruments

The measuring equipment is listed in the section 4 of this test report.

### 3.4.3 Test Procedures

1. The testing follows FCC KDB 789033 D02 General UNII Test Procedures New Rules v01. Section G) Unwanted emissions measurement.

(1) Procedure for Unwanted Emissions Measurements Below 1000MHz

- RBW = 120 kHz
- VBW = 300 kHz
- Detector = Peak
- Trace mode = max hold

(2) Procedure for Peak Unwanted Emissions Measurements Above 1000 MHz

- RBW = 1 MHz
- VBW  $\geq$  3 MHz
- Detector = Peak
- Sweep time = auto
- Trace mode = max hold

(3) Procedures for Average Unwanted Emissions Measurements Above 1000MHz

- RBW = 1 MHz
- VBW = 10 Hz, when duty cycle is no less than 98 percent.
- $VBW \geq 1/T$ , when duty cycle is less than 98 percent where T is the minimum transmission duration over which the transmitter is on and is transmitting at its maximum power control level for the tested mode of operation.

Antenna	Band	Duty Cycle(%)	T(us)	1/T(kHz)	VBW Setting
1	802.11a	94.95	2070	0.48	1kHz
2	802.11a	94.95	2070	0.48	1kHz
1+2	802.11n HT20 for Ant1	95.02	1910	0.52	1kHz
1+2	802.11n HT20 for Ant2	95.52	1920	0.52	
1+2	802.11n HT40 for Ant1	90.29	930	1.08	3kHz
1+2	802.11n HT40 for Ant2	90.29	930	1.08	

2. The EUT was placed on a rotatable table top 0.8 meter above ground.
3. The EUT was set 3 meters from the interference receiving antenna which was mounted on the top of a variable height antenna tower.
4. The antenna is a broadband antenna and its height is adjusted between one meter and four meters above ground to find the maximum value of the field strength for both horizontal polarization and vertical polarization of the antenna.
5. For each suspected emission, the EUT was arranged to its worst case and then adjust the antenna tower (from 1 m to 4 m) and turntable (from 0 degree to 360 degrees) to find the maximum reading.
6. For testing below 1GHz, if the emission level of the EUT in peak mode was 3 dB lower than the limit specified, then peak values of EUT will be reported, otherwise, the emissions will be repeated one by one using the CISPR quasi-peak method and reported.
7. For testing above 1GHz, the emission level of the EUT in peak mode was 20dB lower than average limit (that means the emission level in average mode also complies with the limit in average mode), then peak values of EUT will be reported, otherwise, the emissions will be measured in average mode again and reported.

### 3.4.4 Test Setup

For radiated emissions below 30MHz

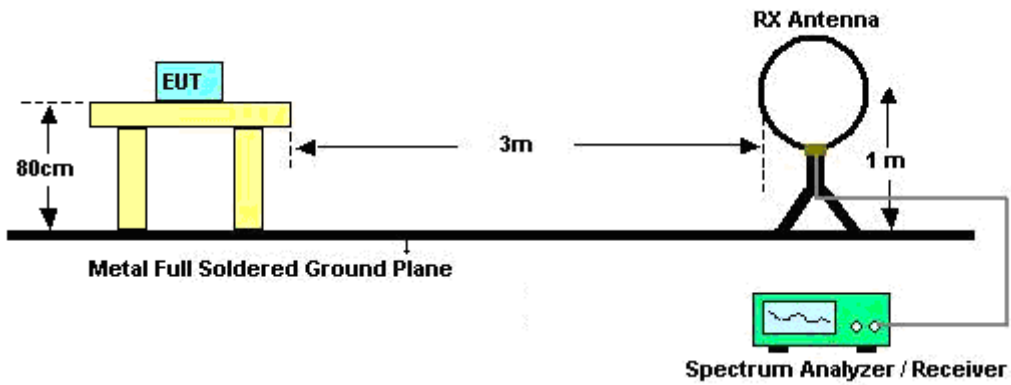

For radiated emissions from 30MHz to 1GHz

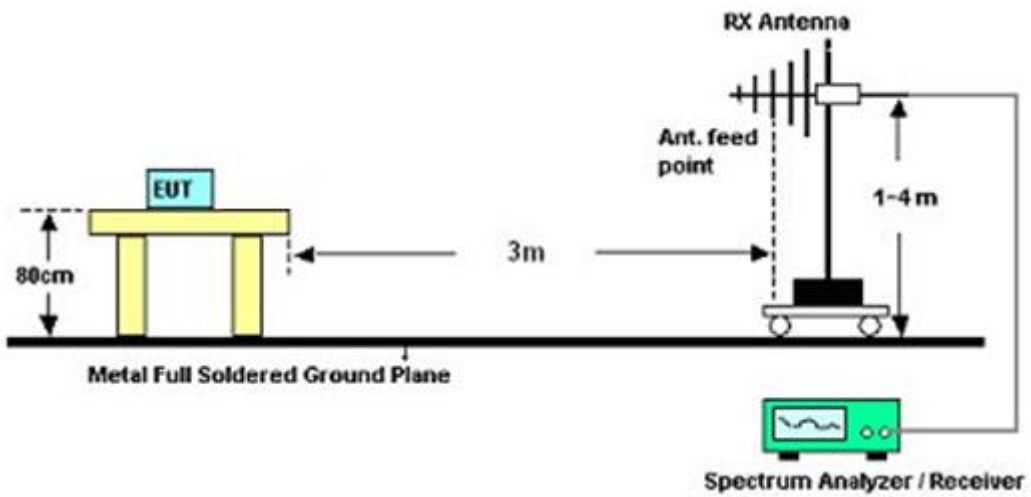



For radiated emissions above 1GHz

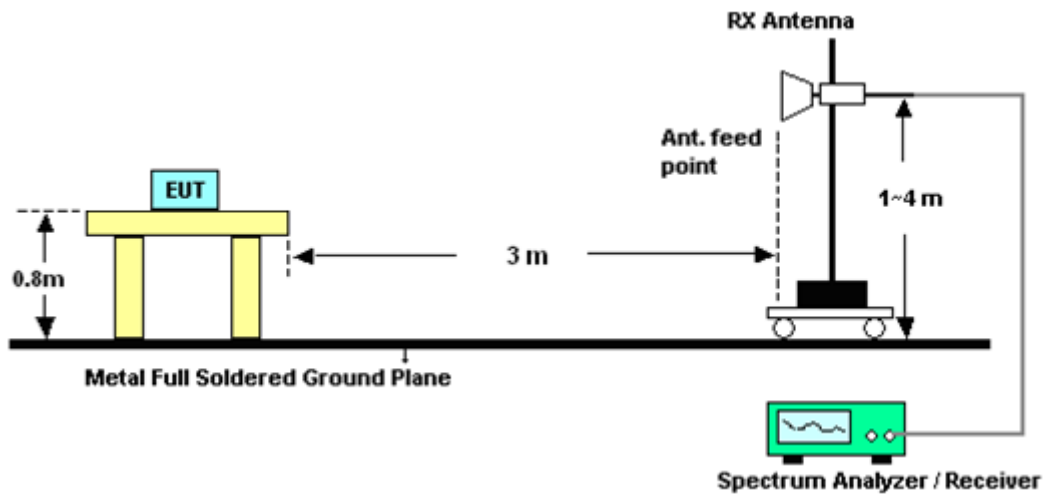

### 3.4.5 Test Results of Radiated Emissions (9 kHz ~ 30 MHz)

The low frequency, which started from 9 kHz to 30MHz, was pre-scanned and the result which was 20dB lower than the limit line per 15.31(o) was not reported.

### 3.4.6 Test Result of Radiated Band Edges

<Ant. 1>

Test Mode :	802.11a	Temperature :	21~25°C
Test Channel :	149	Relative Humidity :	49~53%
Test Engineer :	Kai Wang and Stan Hsieh		

ANTENNA POLARITY : HORIZONTAL										
Frequency ( MHz )	Level ( dBμV/m )	Over Limit ( dB )	Limit Line ( dBμV/m )	Read Level ( dBμV )	Antenna Factor ( dB )	Cable Loss ( dB )	Preamp Factor ( dB )	Ant Pos ( cm )	Table Pos ( deg )	Remark
5714.28	63.91	-4.39	68.3	52.82	35.22	10.02	34.15	100	252	Peak
5724.84	77.79	-0.51	78.3	66.67	35.23	10.04	34.15	100	252	Peak

ANTENNA POLARITY : VERTICAL										
Frequency ( MHz )	Level ( dBμV/m )	Over Limit ( dB )	Limit Line ( dBμV/m )	Read Level ( dBμV )	Antenna Factor ( dB )	Cable Loss ( dB )	Preamp Factor ( dB )	Ant Pos ( cm )	Table Pos ( deg )	Remark
5713.64	64.15	-4.15	68.3	53.06	35.22	10.02	34.15	195	92	Peak
5724.12	75.03	-3.27	78.3	63.91	35.23	10.04	34.15	195	92	Peak

Test Mode :	802.11a	Temperature :	21~25°C
Test Channel :	165	Relative Humidity :	49~53%
Test Engineer :	Kai Wang and Stan Hsieh		

ANTENNA POLARITY : HORIZONTAL										
Frequency ( MHz )	Level ( dBμV/m )	Over Limit ( dB )	Limit Line ( dBμV/m )	Read Level ( dBμV )	Antenna Factor ( dB )	Cable Loss ( dB )	Preamp Factor ( dB )	Ant Pos ( cm )	Table Pos ( deg )	Remark
5855.6	70.29	-8.01	78.3	59.15	35.32	10.13	34.31	100	248	Peak
5860.24	64.74	-3.56	68.3	53.62	35.32	10.15	34.35	100	248	Peak

ANTENNA POLARITY : VERTICAL										
Frequency ( MHz )	Level ( dBμV/m )	Over Limit ( dB )	Limit Line ( dBμV/m )	Read Level ( dBμV )	Antenna Factor ( dB )	Cable Loss ( dB )	Preamp Factor ( dB )	Ant Pos ( cm )	Table Pos ( deg )	Remark
5850.4	70.9	-7.4	78.3	59.77	35.31	10.13	34.31	192	90	Peak
5860	64.23	-14.07	78.3	53.13	35.32	10.13	34.35	192	90	Peak

<Ant. 2>

<b>Test Mode :</b>	802.11a	<b>Temperature :</b>	21~25°C
<b>Test Channel :</b>	149	<b>Relative Humidity :</b>	49~53%
<b>Test Engineer :</b>	Kai Wang and Stan Hsieh		

ANTENNA POLARITY : HORIZONTAL										
Frequency ( MHz )	Level ( dBμV/m )	Over Limit ( dB )	Limit Line ( dBμV/m )	Read Level ( dBμV )	Antenna Factor ( dB )	Cable Loss ( dB )	Preamp Factor ( dB )	Ant Pos ( cm )	Table Pos ( deg )	Remark
5709.32	66.74	-1.56	68.3	55.65	35.22	10.02	34.15	101	174	Peak
5724.36	76.1	-2.2	78.3	64.98	35.23	10.04	34.15	101	174	Peak

ANTENNA POLARITY : VERTICAL										
Frequency ( MHz )	Level ( dBμV/m )	Over Limit ( dB )	Limit Line ( dBμV/m )	Read Level ( dBμV )	Antenna Factor ( dB )	Cable Loss ( dB )	Preamp Factor ( dB )	Ant Pos ( cm )	Table Pos ( deg )	Remark
5714.92	65.32	-2.98	68.3	54.23	35.22	10.02	34.15	196	79	Peak
5723.8	74.75	-3.55	78.3	63.63	35.23	10.04	34.15	196	79	Peak

<b>Test Mode :</b>	802.11a	<b>Temperature :</b>	21~25°C
<b>Test Channel :</b>	165	<b>Relative Humidity :</b>	49~53%
<b>Test Engineer :</b>	Kai Wang and Stan Hsieh		

ANTENNA POLARITY : HORIZONTAL										
Frequency ( MHz )	Level ( dBμV/m )	Over Limit ( dB )	Limit Line ( dBμV/m )	Read Level ( dBμV )	Antenna Factor ( dB )	Cable Loss ( dB )	Preamp Factor ( dB )	Ant Pos ( cm )	Table Pos ( deg )	Remark
5851.52	68.96	-9.34	78.3	57.83	35.31	10.13	34.31	100	173	Peak
5861.92	64.6	-3.7	68.3	53.48	35.32	10.15	34.35	100	173	Peak

ANTENNA POLARITY : VERTICAL										
Frequency ( MHz )	Level ( dBμV/m )	Over Limit ( dB )	Limit Line ( dBμV/m )	Read Level ( dBμV )	Antenna Factor ( dB )	Cable Loss ( dB )	Preamp Factor ( dB )	Ant Pos ( cm )	Table Pos ( deg )	Remark
5855.12	68.42	-9.88	78.3	57.28	35.32	10.13	34.31	192	81	Peak
5863.68	64.09	-4.21	68.3	52.97	35.32	10.15	34.35	192	81	Peak

MIMO <Ant. 1+2>

Test Mode :	802.11n HT20	Temperature :	21~25°C
Test Channel :	149	Relative Humidity :	49~53%
Test Engineer :	Kai Wang and Stan Hsieh		

ANTENNA POLARITY : HORIZONTAL										
Frequency ( MHz )	Level ( dBμV/m )	Over Limit ( dB )	Limit Line ( dBμV/m )	Read Level ( dBμV )	Antenna Factor ( dB )	Cable Loss ( dB )	Preamp Factor ( dB )	Ant Pos ( cm )	Table Pos ( deg )	Remark
5714.12	67.45	-0.85	68.3	56.36	35.22	10.02	34.15	101	65	Peak
5724.52	77.34	-0.96	78.3	66.22	35.23	10.04	34.15	101	65	Peak

ANTENNA POLARITY : VERTICAL										
Frequency ( MHz )	Level ( dBμV/m )	Over Limit ( dB )	Limit Line ( dBμV/m )	Read Level ( dBμV )	Antenna Factor ( dB )	Cable Loss ( dB )	Preamp Factor ( dB )	Ant Pos ( cm )	Table Pos ( deg )	Remark
5712.36	66.91	-1.39	68.3	55.82	35.22	10.02	34.15	197	96	Peak
5721.8	74.22	-4.08	78.3	63.1	35.23	10.04	34.15	197	96	Peak

Test Mode :	802.11n HT20	Temperature :	21~25°C
Test Channel :	165	Relative Humidity :	49~53%
Test Engineer :	Kai Wang and Stan Hsieh		

ANTENNA POLARITY : HORIZONTAL										
Frequency ( MHz )	Level ( dBμV/m )	Over Limit ( dB )	Limit Line ( dBμV/m )	Read Level ( dBμV )	Antenna Factor ( dB )	Cable Loss ( dB )	Preamp Factor ( dB )	Ant Pos ( cm )	Table Pos ( deg )	Remark
5850	72.68	-5.62	78.3	61.55	35.31	10.13	34.31	100	67	Peak
5861.92	67.34	-0.96	68.3	56.22	35.32	10.15	34.35	100	67	Peak

ANTENNA POLARITY : VERTICAL										
Frequency ( MHz )	Level ( dBμV/m )	Over Limit ( dB )	Limit Line ( dBμV/m )	Read Level ( dBμV )	Antenna Factor ( dB )	Cable Loss ( dB )	Preamp Factor ( dB )	Ant Pos ( cm )	Table Pos ( deg )	Remark
5850	71.56	-6.74	78.3	60.43	35.31	10.13	34.31	195	95	Peak
5860.24	63.93	-4.37	68.3	52.81	35.32	10.15	34.35	195	95	Peak

<b>Test Mode :</b>	802.11n HT40	<b>Temperature :</b>	21~25°C
<b>Test Channel :</b>	151	<b>Relative Humidity :</b>	49~53%
<b>Test Engineer :</b>	Kai Wang and Stan Hsieh		

ANTENNA POLARITY : HORIZONTAL										
Frequency ( MHz )	Level ( dB $\mu$ V/m )	Over Limit ( dB )	Limit Line ( dB $\mu$ V/m )	Read Level ( dB $\mu$ V )	Antenna Factor ( dB )	Cable Loss ( dB )	Preamp Factor ( dB )	Ant Pos ( cm )	Table Pos ( deg )	Remark
5714.04	67.65	-0.65	68.3	56.56	35.22	10.02	34.15	101	66	Peak
5723.88	70.51	-7.79	78.3	59.39	35.23	10.04	34.15	101	66	Peak
5853.2	57.03	-21.27	78.3	45.9	35.31	10.13	34.31	101	61	Peak
5864.16	56.08	-12.22	68.3	44.96	35.32	10.15	34.35	101	61	Peak

ANTENNA POLARITY : VERTICAL										
Frequency ( MHz )	Level ( dB $\mu$ V/m )	Over Limit ( dB )	Limit Line ( dB $\mu$ V/m )	Read Level ( dB $\mu$ V )	Antenna Factor ( dB )	Cable Loss ( dB )	Preamp Factor ( dB )	Ant Pos ( cm )	Table Pos ( deg )	Remark
5709	66.48	-1.82	68.3	55.39	35.22	10.02	34.15	195	96	Peak
5724.28	69.3	-9	78.3	58.18	35.23	10.04	34.15	195	96	Peak
5851.6	56.68	-21.62	78.3	45.55	35.31	10.13	34.31	195	96	Peak
5862.4	56.86	-11.44	68.3	45.74	35.32	10.15	34.35	195	96	Peak

<b>Test Mode :</b>	802.11n HT40	<b>Temperature :</b>	21~25°C
<b>Test Channel :</b>	159	<b>Relative Humidity :</b>	49~53%
<b>Test Engineer :</b>	Kai Wang and Stan Hsieh		

ANTENNA POLARITY : HORIZONTAL										
Frequency ( MHz )	Level ( dBμV/m )	Over Limit ( dB )	Limit Line ( dBμV/m )	Read Level ( dBμV )	Antenna Factor ( dB )	Cable Loss ( dB )	Preamp Factor ( dB )	Ant Pos ( cm )	Table Pos ( deg )	Remark
5713.4	65.07	-3.23	68.3	53.98	35.22	10.02	34.15	137	71	Peak
5724.76	68.32	-9.98	78.3	57.2	35.23	10.04	34.15	137	71	Peak
5854.72	71.97	-6.33	78.3	60.83	35.32	10.13	34.31	137	71	Peak
5861.84	67.79	-0.51	68.3	56.67	35.32	10.15	34.35	137	71	Peak

ANTENNA POLARITY : VERTICAL										
Frequency ( MHz )	Level ( dBμV/m )	Over Limit ( dB )	Limit Line ( dBμV/m )	Read Level ( dBμV )	Antenna Factor ( dB )	Cable Loss ( dB )	Preamp Factor ( dB )	Ant Pos ( cm )	Table Pos ( deg )	Remark
5712.84	63.65	-4.65	68.3	52.56	35.22	10.02	34.15	193	97	Peak
5724.44	64.58	-13.72	78.3	53.46	35.23	10.04	34.15	193	97	Peak
5852.48	69.39	-8.91	78.3	58.26	35.31	10.13	34.31	193	97	Peak
5866.72	65.72	-2.58	68.3	54.6	35.32	10.15	34.35	193	97	Peak

### 3.4.7 Test Result of Unwanted Radiated Emission (30MHz ~ 10th Harmonic)

<Ant. 1>

<b>Test Mode :</b>	802.11a	<b>Temperature :</b>	21~25°C
<b>Test Channel :</b>	149	<b>Relative Humidity :</b>	49~53%
<b>Test Engineer :</b>	Kai Wang and Stan Hsieh	<b>Polarization :</b>	Horizontal
<b>Remark :</b>	1. 5747 MHz is fundamental signal which can be ignored.. 2. 17235 MHz is not within a restricted band, and satisfies 68.3 dB $\mu$ V /m peak emission limit. 3. No spurious emissions are detected other than listed points as below.		

Frequency ( MHz )	Level ( dB $\mu$ V/m )	Over Limit ( dB )	Limit Line ( dB $\mu$ V/m )	Read Level ( dB $\mu$ V )	Antenna Factor ( dB )	Cable Loss ( dB )	Preamp Factor ( dB )	Ant Pos ( cm )	Table Pos ( deg )	Remark
52.14	24.74	-15.26	40	47.53	7.7	0.71	31.2	-	-	Peak
128.01	32.11	-11.39	43.5	50.43	11.64	1.14	31.1	-	-	Peak
226.02	35.95	-10.05	46	54.57	10.92	1.46	31	-	-	Peak
314	36.31	-9.69	46	51.82	13.69	1.8	31	100	129	Peak
666.1	31.21	-14.79	46	38.48	20.33	2.87	30.47	-	-	Peak
891.5	27.49	-18.51	46	31.47	23.01	3.33	30.32	-	-	Peak
5747	100.81	-	-	89.68	35.24	10.06	34.17	100	252	Average
5747	111.76	-	-	100.63	35.24	10.06	34.17	100	252	Peak
11490	43.51	-10.49	54	47.96	38.19	14.33	56.97	100	35	Average
11490	54.43	-19.57	74	58.88	38.19	14.33	56.97	100	35	Peak
17235	55.32	-12.98	68.3	52.7	42.21	16.6	56.19	100	0	Peak

<b>Test Mode :</b>	802.11a	<b>Temperature :</b>	21~25°C
<b>Test Channel :</b>	149	<b>Relative Humidity :</b>	49~53%
<b>Test Engineer :</b>	Kai Wang and Stan Hsieh	<b>Polarization :</b>	Vertical
<b>Remark :</b>	1. 5743 MHz is fundamental signal which can be ignored.. 2. 17235 MHz is not within a restricted band, and satisfies 68.3 dB $\mu$ V /m peak emission limit. 3. No spurious emissions are detected other than listed points as below.		

Frequency ( MHz )	Level ( dB $\mu$ V/m )	Over Limit ( dB )	Limit Line ( dB $\mu$ V/m )	Read Level ( dB $\mu$ V )	Antenna Factor ( dB )	Cable Loss ( dB )	Preamp Factor ( dB )	Ant Pos ( cm )	Table Pos ( deg )	Remark
30	32.68	-7.32	40	43.65	20	0.53	31.5	100	299	Peak
51.6	28.52	-11.48	40	51.11	7.9	0.71	31.2	-	-	Peak
209.82	30.11	-13.39	43.5	50.08	9.77	1.36	31.1	-	-	Peak
332.2	30.75	-15.25	46	45.7	14.19	1.86	31	-	-	Peak
666.1	34.95	-11.05	46	42.22	20.33	2.87	30.47	-	-	Peak
836.9	29.28	-16.72	46	33.94	22.47	3.24	30.37	-	-	Peak
5743	99.85	-	-	88.72	35.24	10.06	34.17	195	92	Average
5743	109.66	-	-	98.53	35.24	10.06	34.17	195	92	Peak
11490	42.35	-11.65	54	46.8	38.19	14.33	56.97	160	220	Average
11490	52.81	-21.19	74	57.26	38.19	14.33	56.97	160	220	Peak
17235	54.42	-13.88	68.3	51.8	42.21	16.6	56.19	100	0	Peak



<b>Test Mode :</b>	802.11a	<b>Temperature :</b>	21~25°C
<b>Test Channel :</b>	157	<b>Relative Humidity :</b>	49~53%
<b>Test Engineer :</b>	Kai Wang and Stan Hsieh	<b>Polarization :</b>	Horizontal
<b>Remark :</b>	1. 5783 MHz is fundamental signal which can be ignored. 2. 17352 MHz is not within a restricted band, and satisfies 68.3 dB $\mu$ V /m peak emission limit. 3. No spurious emissions are detected other than listed points as below.		

Frequency ( MHz )	Level ( dB $\mu$ V/m )	Over Limit ( dB )	Limit Line ( dB $\mu$ V/m )	Read Level ( dB $\mu$ V )	Antenna Factor ( dB )	Cable Loss ( dB )	Preamp Factor ( dB )	Ant Pos ( cm )	Table Pos ( deg )	Remark
5783	101.26	-	-	90.15	35.27	10.07	34.23	101	210	Average
5783	111.15	-	-	100.04	35.27	10.07	34.23	101	210	Peak
11574	43.57	-10.43	54	47.61	38.3	14.44	56.78	156	16	Average
11574	54.72	-19.28	74	58.76	38.3	14.44	56.78	156	16	Peak
17352	54.83	-13.47	68.3	52.18	42.12	16.75	56.22	100	0	Peak

<b>Test Mode :</b>	802.11a	<b>Temperature :</b>	21~25°C
<b>Test Channel :</b>	157	<b>Relative Humidity :</b>	49~53%
<b>Test Engineer :</b>	Kai Wang and Stan Hsieh	<b>Polarization :</b>	Vertical
<b>Remark :</b>	1. 5783 MHz is fundamental signal which can be ignored. 2. 17355 MHz is not within a restricted band, and satisfies 68.3 dB $\mu$ V /m peak emission limit. 3. No spurious emissions are detected other than listed points as below.		

Frequency ( MHz )	Level ( dB $\mu$ V/m )	Over Limit ( dB )	Limit Line ( dB $\mu$ V/m )	Read Level ( dB $\mu$ V )	Antenna Factor ( dB )	Cable Loss ( dB )	Preamp Factor ( dB )	Ant Pos ( cm )	Table Pos ( deg )	Remark
5783	99.8	-	-	88.69	35.27	10.07	34.23	194	93	Average
5783	109.49	-	-	98.38	35.27	10.07	34.23	194	93	Peak
11571	43.13	-10.87	54	47.2	38.3	14.41	56.78	146	219	Average
11571	52.42	-21.58	74	56.49	38.3	14.41	56.78	146	219	Peak
17355	54.98	-13.32	68.3	52.33	42.12	16.75	56.22	100	0	Peak

<b>Test Mode :</b>	802.11a	<b>Temperature :</b>	21~25°C
<b>Test Channel :</b>	165	<b>Relative Humidity :</b>	49~53%
<b>Test Engineer :</b>	Kai Wang and Stan Hsieh	<b>Polarization :</b>	Horizontal
<b>Remark :</b>	<ol style="list-style-type: none"> <li>5823 MHz is fundamental signal which can be ignored..</li> <li>17475 MHz is not within a restricted band, and satisfies 68.3 dB<math>\mu</math>V /m peak emission limit.</li> <li>No spurious emissions are detected other than listed points as below.</li> </ol>		

Frequency ( MHz )	Level ( dB $\mu$ V/m )	Over Limit ( dB )	Limit Line ( dB $\mu$ V/m )	Read Level ( dB $\mu$ V )	Antenna Factor ( dB )	Cable Loss ( dB )	Preamp Factor ( dB )	Ant Pos ( cm )	Table Pos ( deg )	Remark
5823	100.54	-	-	89.4	35.3	10.11	34.27	100	248	Average
5823	110.67	-	-	99.53	35.3	10.11	34.27	100	248	Peak
11658	42.61	-11.39	54	46.24	38.42	14.52	56.57	162	22	Average
11658	52.47	-21.53	74	56.1	38.42	14.52	56.57	162	22	Peak
17475	55.5	-12.8	68.3	52.83	42.03	16.89	56.25	100	0	Peak

<b>Test Mode :</b>	802.11a	<b>Temperature :</b>	21~25°C
<b>Test Channel :</b>	165	<b>Relative Humidity :</b>	49~53%
<b>Test Engineer :</b>	Kai Wang and Stan Hsieh	<b>Polarization :</b>	Vertical
<b>Remark :</b>	<ol style="list-style-type: none"> <li>5826 MHz is fundamental signal which can be ignored.</li> <li>17481 MHz is not within a restricted band, and satisfies 68.3 dB<math>\mu</math>V /m peak emission limit.</li> <li>Average measurement was not performed if peak level went lower than the average limit.</li> <li>No spurious emissions are detected other than listed points as below.</li> </ol>		

Frequency ( MHz )	Level ( dB $\mu$ V/m )	Over Limit ( dB )	Limit Line ( dB $\mu$ V/m )	Read Level ( dB $\mu$ V )	Antenna Factor ( dB )	Cable Loss ( dB )	Preamp Factor ( dB )	Ant Pos ( cm )	Table Pos ( deg )	Remark
5826	100.18	-	-	89.04	35.3	10.11	34.27	192	90	Average
5826	109.85	-	-	98.71	35.3	10.11	34.27	192	90	Peak
11655	49.57	-4.43	54	53.2	38.42	14.52	56.57	100	0	Peak
17481	55.89	-12.41	68.3	53.19	42.03	16.92	56.25	100	0	Peak

<Ant. 2>

<b>Test Mode :</b>	802.11a	<b>Temperature :</b>	21~25°C
<b>Test Channel :</b>	149	<b>Relative Humidity :</b>	49~53%
<b>Test Engineer :</b>	Kai Wang and Stan Hsieh	<b>Polarization :</b>	Horizontal
<b>Remark :</b>	<ol style="list-style-type: none"> <li>5743 MHz is fundamental signal which can be ignored.</li> <li>17235 MHz is not within a restricted band, and satisfies 68.3 dB<math>\mu</math>V /m peak emission limit.</li> <li>Average measurement was not performed if peak level went lower than the average limit.</li> <li>No spurious emissions are detected other than listed points as below.</li> </ol>		

Frequency ( MHz )	Level ( dB $\mu$ V/m )	Over Limit ( dB )	Limit Line ( dB $\mu$ V/m )	Read Level ( dB $\mu$ V )	Antenna Factor ( dB )	Cable Loss ( dB )	Preamp Factor ( dB )	Ant Pos ( cm )	Table Pos ( deg )	Remark
5743	101.57	-	-	90.44	35.24	10.06	34.17	101	174	Average
5743	111.49	-	-	100.36	35.24	10.06	34.17	101	174	Peak
11490	47.37	-6.63	54	51.82	38.19	14.33	56.97	100	0	Peak
17235	51.52	-16.78	68.3	48.9	42.21	16.6	56.19	100	0	Peak

<b>Test Mode :</b>	802.11a	<b>Temperature :</b>	21~25°C
<b>Test Channel :</b>	149	<b>Relative Humidity :</b>	49~53%
<b>Test Engineer :</b>	Kai Wang and Stan Hsieh	<b>Polarization :</b>	Vertical
<b>Remark :</b>	<ol style="list-style-type: none"> <li>5747 MHz is fundamental signal which can be ignored.</li> <li>17235 MHz is not within a restricted band, and satisfies 68.3 dB<math>\mu</math>V /m peak emission limit.</li> <li>Average measurement was not performed if peak level went lower than the average limit.</li> <li>No spurious emissions are detected other than listed points as below.</li> </ol>		

Frequency ( MHz )	Level ( dB $\mu$ V/m )	Over Limit ( dB )	Limit Line ( dB $\mu$ V/m )	Read Level ( dB $\mu$ V )	Antenna Factor ( dB )	Cable Loss ( dB )	Preamp Factor ( dB )	Ant Pos ( cm )	Table Pos ( deg )	Remark
5747	100.56	-	-	89.43	35.24	10.06	34.17	196	79	Average
5747	111.59	-	-	100.46	35.24	10.06	34.17	196	79	Peak
11490	48.01	-5.99	54	52.46	38.19	14.33	56.97	100	0	Peak
17235	51.28	-17.02	68.3	48.66	42.21	16.6	56.19	100	0	Peak

<b>Test Mode :</b>	802.11a	<b>Temperature :</b>	21~25°C
<b>Test Channel :</b>	157	<b>Relative Humidity :</b>	49~53%
<b>Test Engineer :</b>	Kai Wang and Stan Hsieh	<b>Polarization :</b>	Horizontal
<b>Remark :</b>	<ol style="list-style-type: none"> <li>5787 MHz is fundamental signal which can be ignored.</li> <li>17358 MHz is not within a restricted band, and satisfies 68.3 dB<math>\mu</math>V /m peak emission limit.</li> <li>Average measurement was not performed if peak level went lower than the average limit.</li> <li>No spurious emissions are detected other than listed points as below.</li> </ol>		

Frequency ( MHz )	Level ( dB $\mu$ V/m )	Over Limit ( dB )	Limit Line ( dB $\mu$ V/m )	Read Level ( dB $\mu$ V )	Antenna Factor ( dB )	Cable Loss ( dB )	Preamp Factor ( dB )	Ant Pos ( cm )	Table Pos ( deg )	Remark
5787	101	-	-	89.88	35.28	10.07	34.23	100	173	Average
5787	111.24	-	-	100.12	35.28	10.07	34.23	100	173	Peak
11568	49.4	-4.6	54	53.47	38.3	14.41	56.78	100	0	Peak
17358	50.12	-18.18	68.3	47.44	42.12	16.78	56.22	100	0	Peak

<b>Test Mode :</b>	802.11a	<b>Temperature :</b>	21~25°C
<b>Test Channel :</b>	157	<b>Relative Humidity :</b>	49~53%
<b>Test Engineer :</b>	Kai Wang and Stan Hsieh	<b>Polarization :</b>	Vertical
<b>Remark :</b>	<ol style="list-style-type: none"> <li>5783 MHz is fundamental signal which can be ignored.</li> <li>17358 MHz is not within a restricted band, and satisfies 68.3 dB<math>\mu</math>V /m peak emission limit.</li> <li>Average measurement was not performed if peak level went lower than the average limit.</li> <li>No spurious emissions are detected other than listed points as below.</li> </ol>		

Frequency ( MHz )	Level ( dB $\mu$ V/m )	Over Limit ( dB )	Limit Line ( dB $\mu$ V/m )	Read Level ( dB $\mu$ V )	Antenna Factor ( dB )	Cable Loss ( dB )	Preamp Factor ( dB )	Ant Pos ( cm )	Table Pos ( deg )	Remark
5783	100.47	-	-	89.36	35.27	10.07	34.23	196	79	Average
5783	109.83	-	-	98.72	35.27	10.07	34.23	196	79	Peak
11568	50.5	-3.5	54	54.57	38.3	14.41	56.78	100	0	Peak
17358	53.68	-14.62	68.3	51	42.12	16.78	56.22	100	0	Peak

<b>Test Mode :</b>	802.11a	<b>Temperature :</b>	21~25°C
<b>Test Channel :</b>	165	<b>Relative Humidity :</b>	49~53%
<b>Test Engineer :</b>	Kai Wang and Stan Hsieh	<b>Polarization :</b>	Horizontal
<b>Remark :</b>	<ol style="list-style-type: none"> <li>5824 MHz is fundamental signal which can be ignored.</li> <li>17475 MHz is not within a restricted band, and satisfies 68.3 dB<math>\mu</math>V /m peak emission limit.</li> <li>Average measurement was not performed if peak level went lower than the average limit.</li> <li>No spurious emissions are detected other than listed points as below.</li> </ol>		

Frequency ( MHz )	Level ( dB $\mu$ V/m )	Over Limit ( dB )	Limit Line ( dB $\mu$ V/m )	Read Level ( dB $\mu$ V )	Antenna Factor ( dB )	Cable Loss ( dB )	Preamp Factor ( dB )	Ant Pos ( cm )	Table Pos ( deg )	Remark
5824	100.69	-	-	89.55	35.3	10.11	34.27	100	173	Average
5824	110.36	-	-	99.22	35.3	10.11	34.27	100	173	Peak
11652	50	-4	54	53.63	38.42	14.52	56.57	100	0	Peak
17475	50.14	-18.16	68.3	47.47	42.03	16.89	56.25	100	0	Peak

<b>Test Mode :</b>	802.11a	<b>Temperature :</b>	21~25°C
<b>Test Channel :</b>	165	<b>Relative Humidity :</b>	49~53%
<b>Test Engineer :</b>	Kai Wang and Stan Hsieh	<b>Polarization :</b>	Vertical
<b>Remark :</b>	<ol style="list-style-type: none"> <li>5823 MHz is fundamental signal which can be ignored.</li> <li>17475 MHz is not within a restricted band, and satisfies 68.3 dB<math>\mu</math>V /m peak emission limit.</li> <li>Average measurement was not performed if peak level went lower than the average limit.</li> <li>No spurious emissions are detected other than listed points as below.</li> </ol>		

Frequency ( MHz )	Level ( dB $\mu$ V/m )	Over Limit ( dB )	Limit Line ( dB $\mu$ V/m )	Read Level ( dB $\mu$ V )	Antenna Factor ( dB )	Cable Loss ( dB )	Preamp Factor ( dB )	Ant Pos ( cm )	Table Pos ( deg )	Remark
5823	100.17	-	-	89.03	35.3	10.11	34.27	192	81	Average
5823	109.62	-	-	98.48	35.3	10.11	34.27	192	81	Peak
11652	49.97	-4.03	54	53.6	38.42	14.52	56.57	100	0	Peak
17475	50.68	-17.62	68.3	48.01	42.03	16.89	56.25	100	0	Peak

**MIMO <Ant. 1+2>**

<b>Test Mode :</b>	802.11n HT20	<b>Temperature :</b>	21~25°C
<b>Test Channel :</b>	149	<b>Relative Humidity :</b>	49~53%
<b>Test Engineer :</b>	Kai Wang and Stan Hsieh	<b>Polarization :</b>	Horizontal
<b>Remark :</b>	<ol style="list-style-type: none"> <li>5748 MHz is fundamental signal which can be ignored.</li> <li>17235 MHz is not within a restricted band, and satisfies 68.3 dB<math>\mu</math>V /m peak emission limit.</li> <li>Average measurement was not performed if peak level went lower than the average limit.</li> <li>No spurious emissions are detected other than listed points as below.</li> </ol>		

Frequency ( MHz )	Level ( dB $\mu$ V/m )	Over Limit ( dB )	Limit Line ( dB $\mu$ V/m )	Read Level ( dB $\mu$ V )	Antenna Factor ( dB )	Cable Loss ( dB )	Preamp Factor ( dB )	Ant Pos ( cm )	Table Pos ( deg )	Remark
5748	103.54	-	-	92.41	35.24	10.06	34.17	101	65	Average
5748	114.21	-	-	103.08	35.24	10.06	34.17	101	65	Peak
11493	48.74	-5.26	54	53.19	38.19	14.33	56.97	100	0	Peak
17235	51.47	-16.83	68.3	48.85	42.21	16.6	56.19	100	0	Peak

<b>Test Mode :</b>	802.11n HT20	<b>Temperature :</b>	21~25°C
<b>Test Channel :</b>	149	<b>Relative Humidity :</b>	49~53%
<b>Test Engineer :</b>	Kai Wang and Stan Hsieh	<b>Polarization :</b>	Vertical
<b>Remark :</b>	<ol style="list-style-type: none"> <li>5748 MHz is fundamental signal which can be ignored.</li> <li>17235 MHz is not within a restricted band, and satisfies 68.3 dB<math>\mu</math>V /m peak emission limit.</li> <li>Average measurement was not performed if peak level went lower than the average limit.</li> <li>No spurious emissions are detected other than listed points as below.</li> </ol>		

Frequency ( MHz )	Level ( dB $\mu$ V/m )	Over Limit ( dB )	Limit Line ( dB $\mu$ V/m )	Read Level ( dB $\mu$ V )	Antenna Factor ( dB )	Cable Loss ( dB )	Preamp Factor ( dB )	Ant Pos ( cm )	Table Pos ( deg )	Remark
5748	102.64	-	-	91.51	35.24	10.06	34.17	197	96	Average
5748	112.83	-	-	101.7	35.24	10.06	34.17	197	96	Peak
11493	48.83	-5.17	54	53.28	38.19	14.33	56.97	100	0	Peak
17235	52.84	-15.46	68.3	50.22	42.21	16.6	56.19	100	0	Peak

<b>Test Mode :</b>	802.11n HT20	<b>Temperature :</b>	21~25°C
<b>Test Channel :</b>	157	<b>Relative Humidity :</b>	49~53%
<b>Test Engineer :</b>	Kai Wang and Stan Hsieh	<b>Polarization :</b>	Horizontal
<b>Remark :</b>	1. 5790 MHz is fundamental signal which can be ignored. 2. 17355 MHz is not within a restricted band, and satisfies 68.3 dB $\mu$ V /m peak emission limit. 3. No spurious emissions are detected other than listed points as below.		

Frequency ( MHz )	Level ( dB $\mu$ V/m )	Over Limit ( dB )	Limit Line ( dB $\mu$ V/m )	Read Level ( dB $\mu$ V )	Antenna Factor ( dB )	Cable Loss ( dB )	Preamp Factor ( dB )	Ant Pos ( cm )	Table Pos ( deg )	Remark
5790	106.41	-	-	95.27	35.28	10.09	34.23	100	68	Average
5790	116.35	-	-	105.21	35.28	10.09	34.23	100	68	Peak
11571	45.83	-8.17	54	49.9	38.3	14.41	56.78	158	343	Average
11571	62.12	-11.88	74	66.19	38.3	14.41	56.78	158	343	Peak
17355	55	-13.3	68.3	52.35	42.12	16.75	56.22	100	0	Peak

<b>Test Mode :</b>	802.11n HT20	<b>Temperature :</b>	21~25°C
<b>Test Channel :</b>	157	<b>Relative Humidity :</b>	49~53%
<b>Test Engineer :</b>	Kai Wang and Stan Hsieh	<b>Polarization :</b>	Vertical
<b>Remark :</b>	1. 5790 MHz is fundamental signal which can be ignored. 2. 17355 MHz is not within a restricted band, and satisfies 68.3 dB $\mu$ V /m peak emission limit. 3. No spurious emissions are detected other than listed points as below.		

Frequency ( MHz )	Level ( dB $\mu$ V/m )	Over Limit ( dB )	Limit Line ( dB $\mu$ V/m )	Read Level ( dB $\mu$ V )	Antenna Factor ( dB )	Cable Loss ( dB )	Preamp Factor ( dB )	Ant Pos ( cm )	Table Pos ( deg )	Remark
5790	105.6	-	-	94.46	35.28	10.09	34.23	195	95	Average
5790	115.5	-	-	104.36	35.28	10.09	34.23	195	95	Peak
11565	45.21	-8.79	54	49.35	38.27	14.41	56.82	148	158	Average
11565	61.23	-12.77	74	65.37	38.27	14.41	56.82	148	158	Peak
17355	55.16	-13.14	68.3	52.51	42.12	16.75	56.22	100	0	Peak

<b>Test Mode :</b>	802.11n HT20	<b>Temperature :</b>	21~25°C
<b>Test Channel :</b>	165	<b>Relative Humidity :</b>	49~53%
<b>Test Engineer :</b>	Kai Wang and Stan Hsieh	<b>Polarization :</b>	Horizontal
<b>Remark :</b>	1. 5830 MHz is fundamental signal which can be ignored. 2. 17481 MHz is not within a restricted band, and satisfies 68.3 dB $\mu$ V /m peak emission limit. 3. No spurious emissions are detected other than listed points as below.		

Frequency ( MHz )	Level ( dB $\mu$ V/m )	Over Limit ( dB )	Limit Line ( dB $\mu$ V/m )	Read Level ( dB $\mu$ V )	Antenna Factor ( dB )	Cable Loss ( dB )	Preamp Factor ( dB )	Ant Pos ( cm )	Table Pos ( deg )	Remark
5830	104.19	-	-	93.05	35.3	10.11	34.27	100	67	Average
5830	114.58	-	-	103.44	35.3	10.11	34.27	100	67	Peak
11655	43.87	-10.13	54	47.5	38.42	14.52	56.57	150	341	Average
11655	60.18	-13.82	74	63.81	38.42	14.52	56.57	150	341	Peak
17481	56.23	-12.07	68.3	53.53	42.03	16.92	56.25	100	0	Peak

<b>Test Mode :</b>	802.11n HT20	<b>Temperature :</b>	21~25°C
<b>Test Channel :</b>	165	<b>Relative Humidity :</b>	49~53%
<b>Test Engineer :</b>	Kai Wang and Stan Hsieh	<b>Polarization :</b>	Vertical
<b>Remark :</b>	1. 5830 MHz is fundamental signal which can be ignored. 2. 17481 MHz is not within a restricted band, and satisfies 68.3 dB $\mu$ V /m peak emission limit. 3. No spurious emissions are detected other than listed points as below.		

Frequency ( MHz )	Level ( dB $\mu$ V/m )	Over Limit ( dB )	Limit Line ( dB $\mu$ V/m )	Read Level ( dB $\mu$ V )	Antenna Factor ( dB )	Cable Loss ( dB )	Preamp Factor ( dB )	Ant Pos ( cm )	Table Pos ( deg )	Remark
5830	103.56	-	-	92.42	35.3	10.11	34.27	195	95	Average
5830	112.97	-	-	101.83	35.3	10.11	34.27	195	95	Peak
11655	43.17	-10.83	54	46.8	38.42	14.52	56.57	148	26	Average
11655	59.28	-14.72	74	62.91	38.42	14.52	56.57	148	26	Peak
17481	54.09	-14.21	68.3	51.39	42.03	16.92	56.25	100	0	Peak



<b>Test Mode :</b>	802.11n HT40	<b>Temperature :</b>	21~25°C
<b>Test Channel :</b>	151	<b>Relative Humidity :</b>	49~53%
<b>Test Engineer :</b>	Kai Wang and Stan Hsieh	<b>Polarization :</b>	Horizontal
<b>Remark :</b>	<ol style="list-style-type: none"> <li>5758 MHz is fundamental signal which can be ignored.</li> <li>17265 MHz is not within a restricted band, and satisfies 68.3 dB<math>\mu</math>V /m peak emission limit.</li> <li>Average measurement was not performed if peak level went lower than the average limit.</li> <li>No spurious emissions are detected other than listed points as below.</li> </ol>		

Frequency ( MHz )	Level ( dB $\mu$ V/m )	Over Limit ( dB )	Limit Line ( dB $\mu$ V/m )	Read Level ( dB $\mu$ V )	Antenna Factor ( dB )	Cable Loss ( dB )	Preamp Factor ( dB )	Ant Pos ( cm )	Table Pos ( deg )	Remark
5758	99.47	-	-	88.35	35.26	10.06	34.2	101	66	Average
5758	108.6	-	-	97.48	35.26	10.06	34.2	101	66	Peak
11511	46.98	-7.02	54	51.38	38.2	14.35	56.95	100	0	Peak
17265	50.29	-18.01	68.3	47.64	42.19	16.66	56.2	100	0	Peak

<b>Test Mode :</b>	802.11n HT40	<b>Temperature :</b>	21~25°C
<b>Test Channel :</b>	151	<b>Relative Humidity :</b>	49~53%
<b>Test Engineer :</b>	Kai Wang and Stan Hsieh	<b>Polarization :</b>	Vertical
<b>Remark :</b>	<ol style="list-style-type: none"> <li>5758 MHz is fundamental signal which can be ignored.</li> <li>17265 MHz is not within a restricted band, and satisfies 68.3 dB<math>\mu</math>V /m peak emission limit.</li> <li>Average measurement was not performed if peak level went lower than the average limit.</li> <li>No spurious emissions are detected other than listed points as below.</li> </ol>		

Frequency ( MHz )	Level ( dB $\mu$ V/m )	Over Limit ( dB )	Limit Line ( dB $\mu$ V/m )	Read Level ( dB $\mu$ V )	Antenna Factor ( dB )	Cable Loss ( dB )	Preamp Factor ( dB )	Ant Pos ( cm )	Table Pos ( deg )	Remark
5758	97.3	-	-	86.18	35.26	10.06	34.2	195	96	Average
5758	107.41	-	-	96.29	35.26	10.06	34.2	195	96	Peak
11511	46.28	-7.72	54	50.68	38.2	14.35	56.95	100	0	Peak
17265	51.3	-17	68.3	48.65	42.19	16.66	56.2	100	0	Peak

<b>Test Mode :</b>	802.11n HT40	<b>Temperature :</b>	21~25°C
<b>Test Channel :</b>	159	<b>Relative Humidity :</b>	49~53%
<b>Test Engineer :</b>	Kai Wang and Stan Hsieh	<b>Polarization :</b>	Horizontal
<b>Remark :</b>	1. 5798 MHz is fundamental signal which can be ignored. 2. 17385 MHz is not within a restricted band, and satisfies 68.3 dB $\mu$ V /m peak emission limit. 3. No spurious emissions are detected other than listed points as below.		

Frequency ( MHz )	Level ( dB $\mu$ V/m )	Over Limit ( dB )	Limit Line ( dB $\mu$ V/m )	Read Level ( dB $\mu$ V )	Antenna Factor ( dB )	Cable Loss ( dB )	Preamp Factor ( dB )	Ant Pos ( cm )	Table Pos ( deg )	Remark
51.87	25.86	-14.14	40	48.65	7.7	0.71	31.2	-	-	Peak
128.82	33.99	-9.51	43.5	52.33	11.62	1.14	31.1	101	182	Peak
216.03	35.55	-10.45	46	54.95	10.24	1.4	31.04	-	-	Peak
311.2	35.71	-10.29	46	51.31	13.61	1.79	31	-	-	Peak
666.1	30.77	-15.23	46	38.04	20.33	2.87	30.47	-	-	Peak
898.5	27.1	-18.9	46	30.98	23.08	3.34	30.3	-	-	Peak
5798	104.39	-	-	93.25	35.28	10.09	34.23	137	71	Average
5798	113.41	-	-	102.27	35.28	10.09	34.23	137	71	Peak
11589	43.07	-10.93	54	47.05	38.32	14.44	56.74	151	344	Average
11589	56.97	-17.03	74	60.95	38.32	14.44	56.74	151	344	Peak
17385	50.13	-18.17	68.3	47.47	42.09	16.8	56.23	100	0	Peak

<b>Test Mode :</b>	802.11n HT40	<b>Temperature :</b>	21~25°C
<b>Test Channel :</b>	159	<b>Relative Humidity :</b>	49~53%
<b>Test Engineer :</b>	Kai Wang and Stan Hsieh	<b>Polarization :</b>	Vertical
<b>Remark :</b>	1. 5798 MHz is fundamental signal which can be ignored. 2. 17385 MHz is not within a restricted band, and satisfies 68.3 dB $\mu$ V /m peak emission limit. 3. No spurious emissions are detected other than listed points as below.		

Frequency ( MHz )	Level ( dB $\mu$ V/m )	Over Limit ( dB )	Limit Line ( dB $\mu$ V/m )	Read Level ( dB $\mu$ V )	Antenna Factor ( dB )	Cable Loss ( dB )	Preamp Factor ( dB )	Ant Pos ( cm )	Table Pos ( deg )	Remark
30	32.54	-7.46	40	43.51	20	0.53	31.5	100	65	Peak
160.68	28.34	-15.16	43.5	47.9	10.41	1.22	31.19	-	-	Peak
209.82	29.85	-13.65	43.5	49.82	9.77	1.36	31.1	-	-	Peak
326.6	29.89	-16.11	46	45.02	14.03	1.84	31	-	-	Peak
664	33.87	-12.13	46	41.16	20.31	2.87	30.47	-	-	Peak
864.2	27.98	-18.02	46	32.32	22.74	3.29	30.37	-	-	Peak
5798	102.65	-	-	91.51	35.28	10.09	34.23	193	97	Average
5798	111.97	-	-	100.83	35.28	10.09	34.23	193	97	Peak
11592	42.04	-11.96	54	46.02	38.32	14.44	56.74	148	23	Average
11592	55.78	-18.22	74	59.76	38.32	14.44	56.74	148	23	Peak
17385	52.26	-16.04	68.3	49.6	42.09	16.8	56.23	100	0	Peak

## 3.5 AC Conducted Emission Measurement

### 3.5.1 Limit of AC Conducted Emission

For equipment that is designed to be connected to the public utility (AC) power line, the radio frequency voltage that is conducted back onto the AC power line on any frequency or frequencies within the band 150 kHz to 30 MHz shall not exceed the limits in the following table.

Frequency of emission (MHz)	Conducted limit (dB $\mu$ V)	
	Quasi-peak	Average
0.15-0.5	66 to 56*	56 to 46*
0.5-5	56	46
5-30	60	50

\*Decreases with the logarithm of the frequency.

### 3.5.2 Measuring Instruments

The measuring equipment is listed in the section 4 of this test report.

### 3.5.3 Test Procedures

1. The EUT was placed 0.4 meter from the conducting wall of the shielding room was kept at least 80 centimeters from any other grounded conducting surface.
2. Connect EUT to the power mains through a line impedance stabilization network (LISN).
3. All the support units are connecting to the other LISN.
4. The LISN provides 50 ohm coupling impedance for the measuring instrument.
5. The FCC states that a 50 ohm, 50 microhenry LISN should be used.
6. Both sides of AC line were checked for maximum conducted interference.
7. The frequency range from 150 kHz to 30 MHz was searched.
8. Set the test-receiver system to Peak Detect Function and specified bandwidth with Maximum Hold Mode.

### 3.5.4 Test Setup

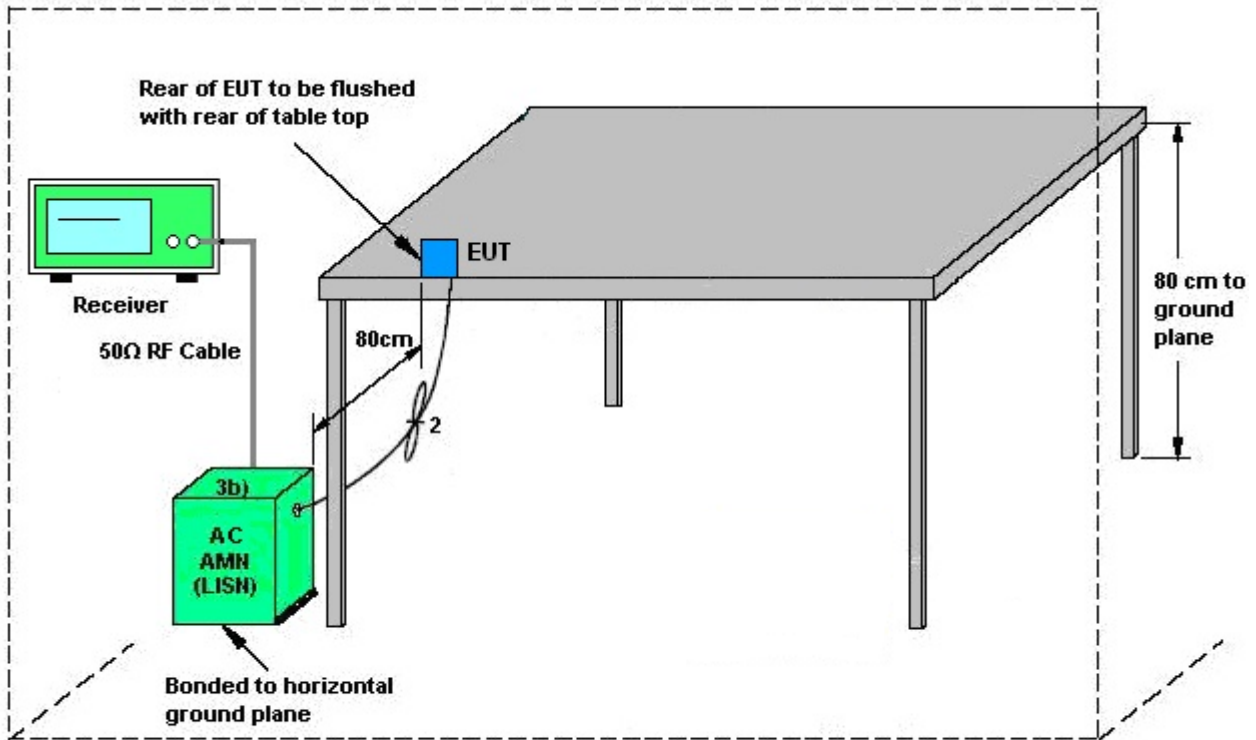

AMN = Artificial mains network (LISN)  
AE = Associated equipment  
EUT = Equipment under test  
ISN = Impedance stabilization network

### 3.5.5 Test Result of AC Conducted Emission

<b>Test Mode :</b>	Mode 1	<b>Temperature :</b>	20~22°C
<b>Test Engineer :</b>	Cosmo Xu	<b>Relative Humidity :</b>	45~47%
<b>Test Voltage :</b>	120Vac / 60Hz	<b>Phase :</b>	Line
<b>Function Type :</b>	WLAN (5GHz) Link + Bluetooth Link + Buttercup + MPEG4 + USB Cable (Charging from Adapter)		

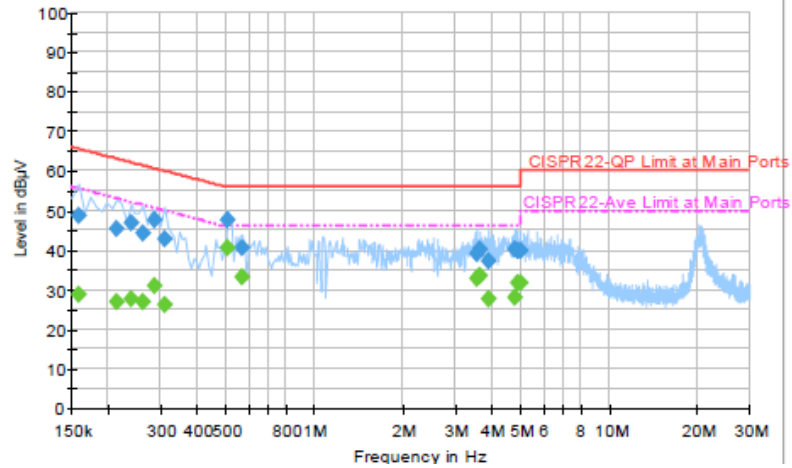

**Final Result : QuasiPeak**

Frequency (MHz)	QuasiPeak (dBµV)	Filter	Line	Corr. (dB)	Margin (dB)	Limit (dBµV)
0.158000	48.7	Off	L1	19.3	16.9	65.6
0.214000	45.4	Off	L1	19.4	17.6	63.0
0.238000	46.9	Off	L1	19.4	15.3	62.2
0.262000	44.4	Off	L1	19.4	17.0	61.4
0.286000	47.5	Off	L1	19.3	13.1	60.6
0.310000	42.8	Off	L1	19.4	17.2	60.0
0.510000	47.5	Off	L1	19.4	8.5	56.0
0.566000	40.4	Off	L1	19.4	15.6	56.0
3.574000	39.3	Off	L1	19.5	16.7	56.0
3.638000	40.1	Off	L1	19.5	15.9	56.0
3.918000	37.2	Off	L1	19.5	18.8	56.0
4.814000	40.4	Off	L1	19.6	15.6	56.0
4.918000	40.0	Off	L1	19.6	16.0	56.0
4.998000	39.9	Off	L1	19.6	16.1	56.0

<b>Test Mode :</b>	Mode 1	<b>Temperature :</b>	20~22°C
<b>Test Engineer :</b>	Cosmo Xu	<b>Relative Humidity :</b>	45~47%
<b>Test Voltage :</b>	120Vac / 60Hz	<b>Phase :</b>	Line
<b>Function Type :</b>	WLAN (5GHz) Link + Bluetooth Link + Buttercup + MPEG4 + USB Cable (Charging from Adapter)		

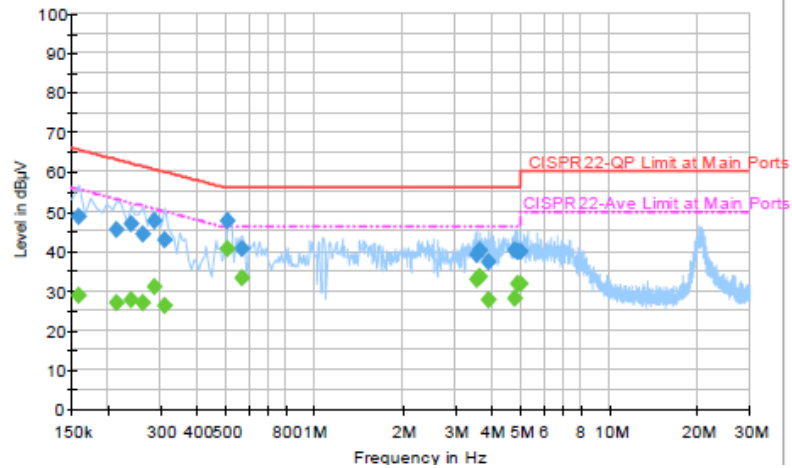

**Final Result : Average**

Frequency (MHz)	Average (dBµV)	Filter	Line	Corr. (dB)	Margin (dB)	Limit (dBµV)
0.158000	28.9	Off	L1	19.3	26.7	55.6
0.214000	27.0	Off	L1	19.4	26.0	53.0
0.238000	27.7	Off	L1	19.4	24.5	52.2
0.262000	27.1	Off	L1	19.4	24.3	51.4
0.286000	30.8	Off	L1	19.3	19.8	50.6
0.310000	26.3	Off	L1	19.4	23.7	50.0
0.510000	40.7	Off	L1	19.4	5.3	46.0
0.566000	33.3	Off	L1	19.4	12.7	46.0
3.574000	32.7	Off	L1	19.5	13.3	46.0
3.638000	33.6	Off	L1	19.5	12.4	46.0
3.918000	27.6	Off	L1	19.5	18.4	46.0
4.814000	28.2	Off	L1	19.6	17.8	46.0
4.918000	31.7	Off	L1	19.6	14.3	46.0
4.998000	31.9	Off	L1	19.6	14.1	46.0

<b>Test Mode :</b>	Mode 1	<b>Temperature :</b>	20~22°C
<b>Test Engineer :</b>	Cosmo Xu	<b>Relative Humidity :</b>	45~47%
<b>Test Voltage :</b>	120Vac / 60Hz	<b>Phase :</b>	Neutral
<b>Function Type :</b>	WLAN (5GHz) Link + Bluetooth Link + Buttercup + MPEG4 + USB Cable (Charging from Adapter)		

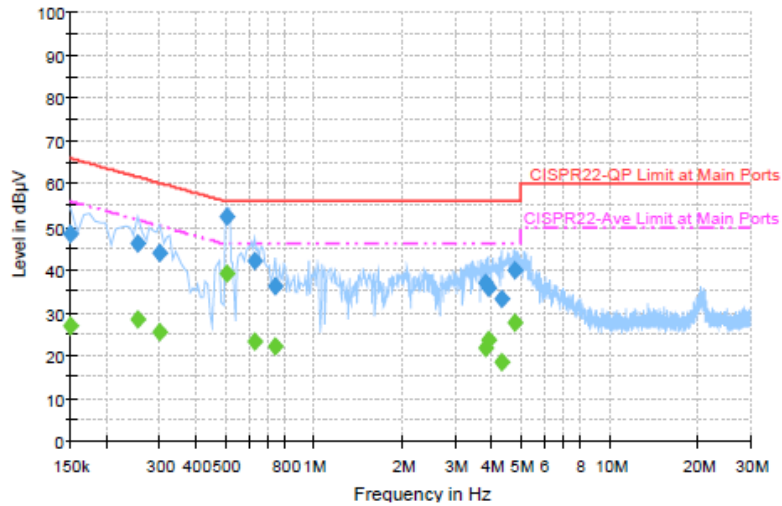

**Final Result : QuasiPeak**

Frequency (MHz)	QuasiPeak (dBµV)	Filter	Line	Corr. (dB)	Margin (dB)	Limit (dBµV)
0.150000	48.2	Off	N	19.4	17.8	66.0
0.254000	46.2	Off	N	19.4	15.4	61.6
0.302000	44.1	Off	N	19.3	16.1	60.2
0.510000	52.5	Off	N	19.4	3.5	56.0
0.630000	42.0	Off	N	19.5	14.0	56.0
0.742000	36.1	Off	N	19.5	19.9	56.0
3.814000	36.8	Off	N	19.6	19.2	56.0
3.894000	35.7	Off	N	19.6	20.3	56.0
4.302000	33.3	Off	N	19.6	22.7	56.0
4.790000	39.7	Off	N	19.6	16.3	56.0

**Final Result : Average**

Frequency (MHz)	Average (dBµV)	Filter	Line	Corr. (dB)	Margin (dB)	Limit (dBµV)
0.150000	26.9	Off	N	19.4	29.1	56.0
0.254000	28.6	Off	N	19.4	23.0	51.6
0.302000	25.6	Off	N	19.3	24.6	50.2
0.510000	39.1	Off	N	19.4	6.9	46.0
0.630000	23.3	Off	N	19.5	22.7	46.0
0.742000	22.2	Off	N	19.5	23.8	46.0
3.814000	21.6	Off	N	19.6	24.4	46.0
3.894000	23.5	Off	N	19.6	22.5	46.0
4.302000	18.5	Off	N	19.6	27.5	46.0
4.790000	27.6	Off	N	19.6	18.4	46.0



## 3.6 Frequency Stability Measurement

### 3.6.1 Limit of Frequency Stability

Manufacturers of U-NII devices are responsible for ensuring frequency stability such that an emission is maintained within the band of operation under all conditions of normal operation as specified in the user's manual.

### 3.6.2 Measuring Instruments

The measuring equipment is listed in the section 4 of this test report.

### 3.6.3 Test Procedures

1. To ensure emission at the band edge is maintained within the authorized band, those values shall be measured by radiation emissions at upper and lower frequency points, and finally compensated by frequency deviation as procedures below.
2. The EUT was operated at the maximum output power, and connected to the spectrum analyzer, which is set to maximum hold function and peak detector. The peak value of the power envelope was measured and noted. The upper and lower frequency points were respectively measured relatively 10dB lower than the measured peak value.
3. The frequency deviation was calculated by adding the upper frequency point and the lower frequency point divided by two. Those detailed values of frequency deviation are provided in table below.

### 3.6.4 Test Setup

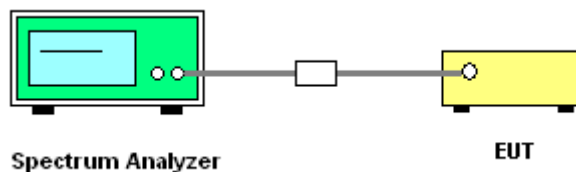

### 3.6.5 Test Result of Frequency Stability

<b>Test Band :</b>	5GHz band IV	<b>Test Engineer :</b>	Stuart Lin
--------------------	--------------	------------------------	------------

Mod.	Data Rate	N <sub>TX</sub>	Channel	Freq. (MHz)	Center Frequency (MHz)	Frequency Deviation (MHz)	Frequency Stability (ppm)	Temperature (°C)	Voltage (V)
11a	6Mbps	1	149	5745	5745.000	0.000	0.00	20	4.75
11a	6Mbps	1	149	5745	5745.000	0.000	0.00	20	5.2
11a	6Mbps	1	149	5745	5745.025	0.025	4.35	20	5
11a	6Mbps	1	149	5745	5745.075	0.075	13.05	-30	5
11a	6Mbps	1	149	5745	5744.975	-0.025	-4.35	50	5

**Note:**

- Center Frequency = (Low Frequency + High Frequency) / 2.

## **3.7 Automatically Discontinue Transmission**

### **3.7.1 Limit of Automatically Discontinue Transmission**

The device shall automatically discontinue transmission in case of either absence of information to transmit or operational failure. These provisions are not intended to preclude the transmission of control or signaling information or the use of repetitive codes used by certain digital technologies to complete frame or burst intervals. Applicants shall include in their application for equipment authorization to describe how this requirement is met.

### **3.7.2 Measuring Instruments**

The measuring equipment is listed in the section 4 of this test report.

### **3.7.3 Test Result of Automatically Discontinue Transmission**

While the EUT is not transmitting any information, the EUT can automatically discontinue transmission and become standby mode for power saving. The EUT can detect the controlling signal of ACK message transmitting from remote device and verify whether it shall resend or discontinue transmission.

## **3.8 Antenna Requirements**

### **3.8.1 Standard Applicable**

According to FCC 47 CFR Section 15.407(a)(1)(2) ,if transmitting antenna directional gain is greater than 6 dBi, both the peak transmit power and the peak power spectral density shall be reduced by the amount in dB that the directional gain of the antenna exceeds 6 dBi.

### **3.8.2 Antenna Anti-Replacement Construction**

Non-standard antenna connector is used.

### 3.8.3 Antenna Gain

FCC KDB 662911 D01 Multiple Transmitter Output v02r01

For CDD transmissions, directional gain is calculated as

$$DirectionalGain = 10 \cdot \log \left[ \frac{\sum_{j=1}^{N_{SS}} \left\{ \sum_{k=1}^{N_{ANT}} g_{j,k} \right\}^2}{N_{ANT}} \right]$$

where

Each antenna is driven by no more than one spatial stream;

$N_{SS}$  = the number of independent spatial streams of data;

$N_{ANT}$  = the total number of antennas

$g_{j,k} = 10^{G_k / 20}$  if the  $k$ th antenna is being fed by spatial stream  $j$ , or zero if it is not;  
 $G_k$  is the gain in dBi of the  $k$ th antenna.

The EUT supports CDD mode.

The power and PSD limit should be modified if the directional gain of EUT is over 6 dBi,

The directional gain "DG" is calculated as following table.

			DG	DG	Power	PSD
			for	for	Limit	Limit
	Ant 1	Ant 2	Power	PSD	Reduction	Reduction
	(dBi)	(dBi)	(dBi)	(dBi)	(dB)	(dB)
<b>Band IV</b>	4.40	7.20	8.92	8.92	2.92	2.92

$Power\ Limit\ Reduction = DG(Power) - 6dBi, (min = 0)$

$PSD\ Limit\ Reduction = DG(PSD) - 6dBi, (min = 0)$

## 4 List of Measuring Equipment

Instrument	Manufacturer	Model No.	Serial No.	Characteristics	Calibration Date	Test Date	Due Date	Remark
Spectrum Analyzer	Rohde & Schwarz	FSP40	100055	9kHz~40GHz	Jun. 09, 2014	Jul. 04, 2014~ Jul. 13, 2014	Jun. 08, 2015	Conducted (TH02-HY)
Power Meter	Anritsu	ML2495A	1036004	300MHz~40GHz	Aug. 17, 2013	Jul. 04, 2014~ Jul. 13, 2014	Aug. 16, 2014	Conducted (TH02-HY)
Power Sensor	Anritsu	MA2411B	1027253	300MHz~40GHz	Aug. 17, 2013	Jul. 04, 2014~ Jul. 13, 2014	Aug. 16, 2014	Conducted (TH02-HY)
Thermal Chamber	Ten Billion	TTH-D3SP	TBN-930701	N/A	Jul. 19, 2013	Jul. 04, 2014~ Jul. 13, 2014	Jul. 18, 2014	Conducted (TH02-HY)
Spectrum Analyzer	Rohde & Schwarz	FSV30	101749	10Hz ~ 30GHz	Feb. 10, 2014	Jul. 03, 2014~ Jul. 08, 2014	Feb. 09, 2015	Radiation (03CH07-HY)
EMI Test Receiver	Rohde & Schwarz	ESCI 7	100724	9kHz~7GHz	Sep. 06, 2013	Jul. 03, 2014~ Jul. 08, 2014	Sep. 05, 2014	Radiation (03CH07-HY)
Loop Antenna	Rohde & Schwarz	HFH2-Z2	100330	9 kHz~30 MHz	Nov. 15, 2012	Jul. 03, 2014~ Jul. 08, 2014	Nov. 14, 2014	Radiation (03CH07-HY)
Bilog Antenna	Schaffner	CBL6111C	2726	30MHz ~ 1GHz	Oct. 10, 2013	Jul. 03, 2014~ Jul. 08, 2014	Oct. 09, 2014	Radiation (03CH07-HY)
Double Ridge Horn Antenna	ESCO	3117	75962	1GHz~18GHz	Aug. 22, 2013	Jul. 03, 2014~ Jul. 08, 2014	Aug. 21, 2014	Radiation (03CH07-HY)
SHF-EHF Horn Antenna	SCHWARZBECK	BBHA 9170	BBHA9170251	15GHz- 40GHz	Oct. 03, 2013	Jul. 03, 2014~ Jul. 08, 2014	Oct. 02, 2014	Radiation (03CH07-HY)
Preamplifier	COM-POWER	PA-103A	161241	10 MHz ~ 1000MHz 32dB GAIN	Mar. 17, 2014	Jul. 03, 2014~ Jul. 08, 2014	Mar. 16, 2015	Radiation (03CH07-HY)
Preamplifier	Agilent	8449B	3008A02362	1 GHz~26.5 GHz	Nov. 29, 2013	Jul. 03, 2014~ Jul. 08, 2014	Nov. 28, 2014	Radiation (03CH07-HY)
Preamplifier	MITEQ	AMF-7D-0010 1800-30-10P	159075	1GHz ~ 18GHz	Apr. 21, 2014	Jul. 03, 2014~ Jul. 08, 2014	Apr. 20, 2015	Radiation (03CH07-HY)
Turn Table	ChainTek	ChainTek 3000	N/A	0 ~ 360 degree	N/A	Jul. 03, 2014~ Jul. 08, 2014	N/A	Radiation (03CH07-HY)
Antenna Mast	ChainTek	ChainTek 3000	N/A	N/A	N/A	Jul. 03, 2014~ Jul. 08, 2014	N/A	Radiation (03CH07-HY)
EMI Test Receiver	Rohde & Schwarz	ESCS 30	100356	9kHz ~ 2.75GHz	Nov. 15, 2013	Jul. 08, 2014	Nov. 14, 2014	Conduction (CO05-HY)
LISN (for auxiliary equipment)	Rohde & Schwarz	ENV216	100081	9kHz ~ 30MHz	Dec. 12, 2013	Jul. 08, 2014	Dec. 11, 2014	Conduction (CO05-HY)
LISN	Rohde & Schwarz	ENV216	100080	9kHz ~ 30MHz	Dec. 04, 2013	Jul. 08, 2014	Dec. 03, 2014	Conduction (CO05-HY)
AC Power Source	ChainTek	APC-1000W	N/A	N/A	N/A	Jul. 08, 2014	N/A	Conduction (CO05-HY)

## 5 Uncertainty of Evaluation

### Uncertainty of Conducted Emission Measurement (150kHz ~ 30MHz)

Measuring Uncertainty for a Level of Confidence of 95% ( $U = 2Uc(y)$ )	2.26
---	------

### Uncertainty of Radiated Emission Measurement (30 MHz ~ 1000 MHz)

Measuring Uncertainty for a Level of Confidence of 95% ( $U = 2Uc(y)$ )	4.50
---	------