

# INSTRUCTION MANUAL

## 6-CH ALL-ALLOY SUPER DRONE

### Key features of quadcopter

- Four-axis struture makes the quadcopter more flexible and rapid when flying. It is wind-resistant and can be flown indoor or outdoor.
- Built-in 6 axis gyroscope for precise hovering in the sky.
- Simple modular design makes changing parts easy.
- With 360° 3D eversion and throwing flight function.

The materials and specification mentioned in this instruction manual or the parts inside this package are for reference only.



# PREFACE

Dear Customers:

Thank you for purchasing our flying model. Please read this instruction manual carefully in order to master the skill more quickly and operate this product more safely. In the mean time, please well keep the original of this instruction manual for future reference.

# IMPORTANT INSTRUCTION

- 1.This product is not a toy but a precise equipment that integrating mechanics and electronics with expertise of aerodynamics and high-frequency transmitting. It requires to be correctly assembled and debugged so as to prevent the accident from being happened.The product owner should operate or control it in safe way. Please noted that we won't take any responsibility for any wrong operation as this may result in severe injury or loss of property and we can not control the operating process during the time when the user assemble or use this product.
- 2.This product is suitable to be used by people who has operating experience in flying model or age no less than 14 years old.
- 3.The flying ground we required should be the local field and legal for remote control flying.
- 4.Once this product is sold , we won't be responsible for any safety responsibility during the time the user operates or uses or controls this product.
- 5.If there is any problem occurred during the time of using, operating or repairing, please reach our sales agent for details.The sales agent that we authorized will provide you with the technical support and after-sale service.

# SAFTY&CAUTIONS

This R/C flying model is a high dangerous commodity.Please make sure that it should be flied far away from the crowd.Please also pay more attention to the phenomenon such as incorrect assembly or damaged model or incorrect connection of electronic control equipment.Please also pay attention to the flying safety when operating and know more about the accident that may be happened due to your own negligence.

- 1 .Keep it far away from the barrier or crowd.
- 2.Keep it far away from the moisten environment.
- 3.Use this product correctly and avoid operating by your own.
4. Keep it far away from the high-speed rotating part and heat source.

# CONTENTS

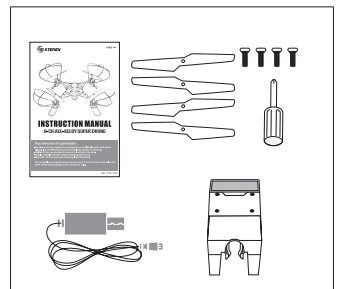
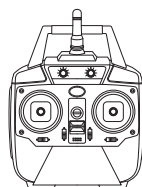
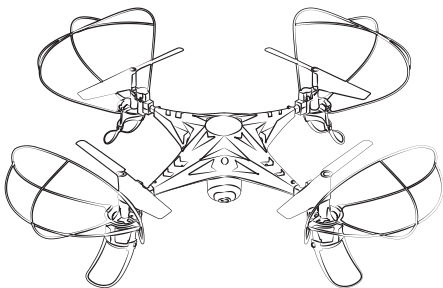

# GET TO KNOW YOUR TRANSMITTER

## INTRODUCTION OF TRANSMITTER

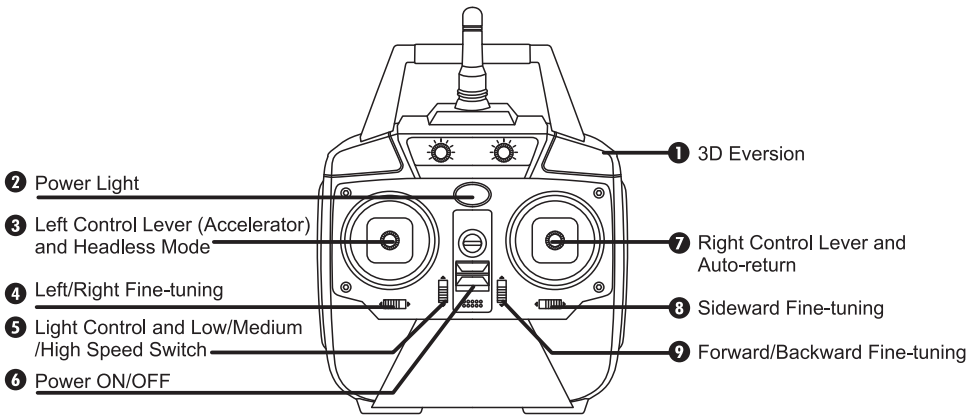

## REMOTE CONTROL INSTALLING THE BATTERY

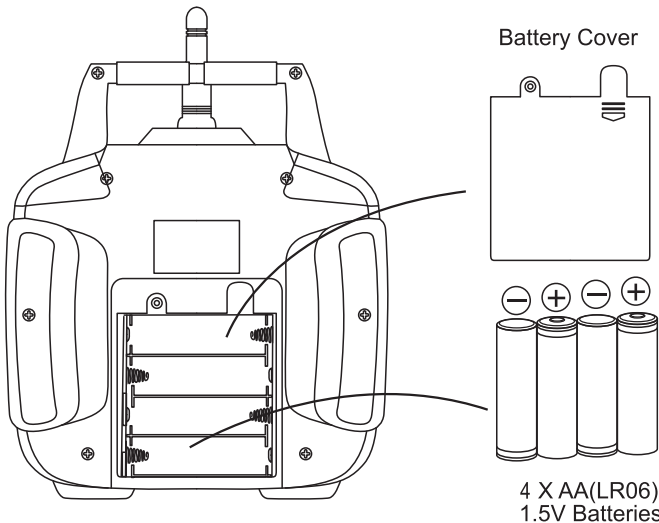

Open the battery cover  
Install 4“AA”  
batteries (not included)  
into the back of transmitter  
than replace battery cover  
and reinstall the screw.



- 1.Install batteries with correct polarity.
- 2.Do not mix old and new batteries.
- 3.Do not mix different types of batteries.

# HOW TO ASSEMBLE AND UNASSEMBLE THE FIXING COMPONENT

## INSTALL FIXING COMPONENT

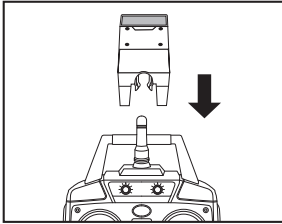

1. Put the back of the mobile phone fixing component to match the antenna and handle of the controller .

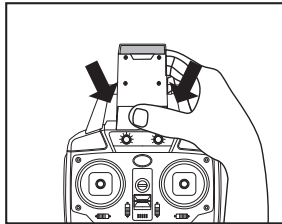

2. Press the controller to clicks into mobile phone fixing component .

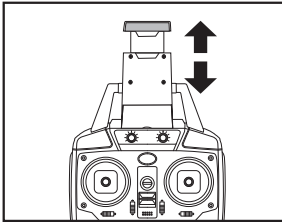

3. Adjust the fixing component upward or downward according mobile phone fixing component to the size of the mobile phone.

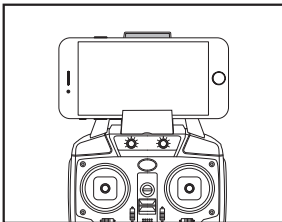

4. After you place the mobile phone on the holder , open the software and you can enjoy the real time video showed on your mobile phone .

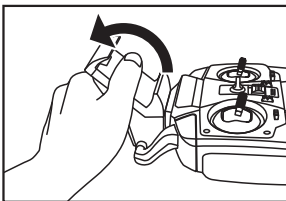

## UNASSEMBLE FIXING COMPONENT

When you want to take out the fixing component, please pull the part according to the direction we marked on picture.

# SOFTWARE DOWNLOAD,INSTALLATION AND USING

## Software Download and Installation



APP (IOS)



Google Paly (Android)

### Using Instruction

1. Connect the model to the power, the indicator on camera turns red.
2. Enter the “setting” menu of your mobile device and turn on WIFI.
3. Find a network WIFI called “RC LEADING” ,click connection until “connected”.
4. Open the “RC LEADING” software, click the “play” icon into the control interface.  
And you will see the real time video.

\* As software will be upgraded once new function adding, the function and window for further version of software please refer to the manual inside software you downloaded.

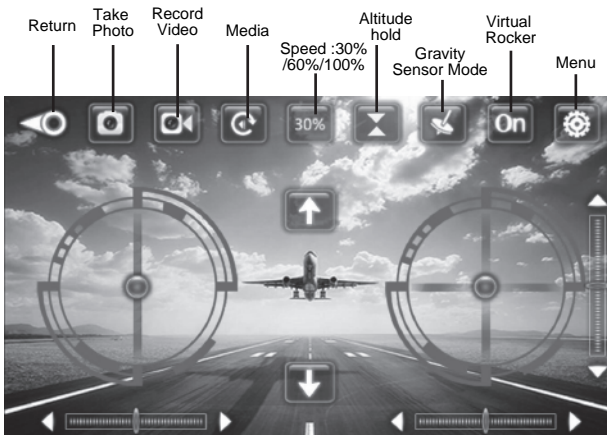

## HOW TO START YOUR QUADCOPTER

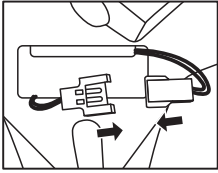

**Step 1:** Connect the battery to the battery port.

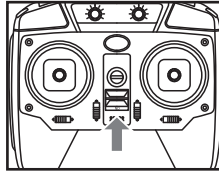

**Step 2:** Press the ON/OFF power switch up.

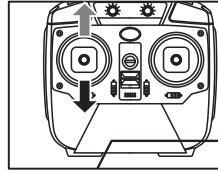

**Step 3:** Push the throttle lever to the highest position, And then pull it back to the lowest position. There will be one clear sound from the transmitter, this shows that the quadcopter has entered into the pre-fly state.

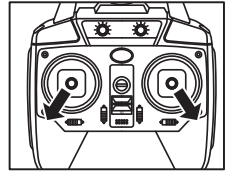

**Step 4:** Pull the left control stick to the left bottom and right control stick to the right bottom, then the motor will be ready to work. This is an extra operation for the product with altitude hold function.

## HOW TO LAND YOUR QUADCOPTER

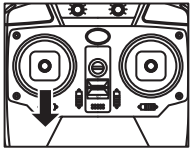

**Way 1:** After playing, control the drone to the ground and keep the throttle at the lowest position for 3-4 seconds or until the motor stop working. Finally switch off the transmitter and drone.



**Way 2:** For fast turn off or any emergency, pull the left control stick to the left bottom and right control stick to the right bottom, then the motor will stop working at once. Please do not do this operation while the product in the sky, or it can fall down suddenly due to non-working motor.

### TIPS:

For the drone with altitude hold function, which means the drone can keep in the same flying altitude, the left control stick (accelerator) will self-return to the center to keep balance. Player can push it up or pull it down to control the drone at the altitude that he wants it to be when release the left control stick (accelerator).

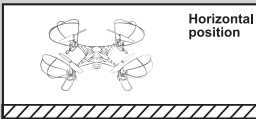

**TIPS:** When syncing your quadcopter keep it in a horizontal position to start to a stable flight.

## CAUTIONS

1. When the indicator of transmitter keep light on but the indicator of quadcopter is blinking slowly, it means signal matching was not successful. Please turn off the power both of transmitter and quadcopter than restart the transmitter and quadcopter.
2. If the quadcopter is still flying to one side dramatically or spinning while hovering, please switch off the power of both the quadcopter and transmitter and then repeat the pre-flying steps.
3. When the indicator of the quadcopter keeps flashing slowly, it means that the quadcopter has entered into the low battery state. This time you need to charge the quadcopter with the USB cable provided.

# CHARGE BATTERY OF QUADCOPTER

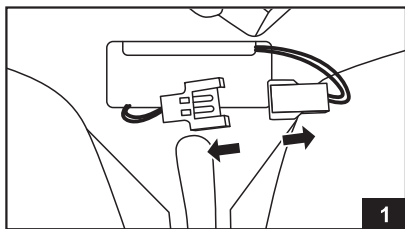

1. Pull out the battery wire from the power port.

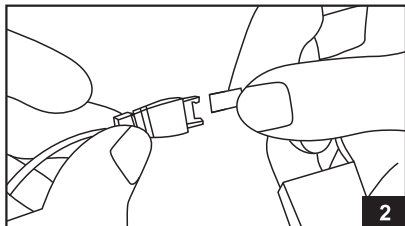

2. Take out the USB charging cable, and insert the battery power port to the small end of it (Make sure the ports connect tight and correct).

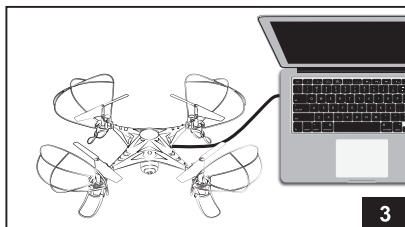

4. To charge battery, please insert the USB port of provided USB charging cable to anyone USB port of computer. The indicator on USB cable will light OFF during charging battery, than it will light ON when battery fully charged.

## Caution:

When using the computer for charging, please remember to pull out the charging cable before shutting down the computer. Take the battery cover, and close the battery cover on the quadcopter.

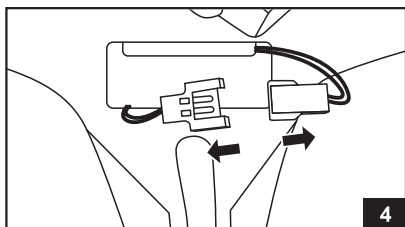

4. Reconnect the battery wire to power port then close the battery cover.

**Charging time: about 90 minutes - Flying time: about 6-8 minutes!**



## CAUTIONS WHEN CHARGING

1. When charging, please put this product on a dried or ventilated area and keep it far away from heat source or explosive product.
2. When charging, please remove the batteries from the quadcopter. Then charging process should be supervised by an adult so as not to cause an accident.
3. After flying, please do not charge the battery if the surface temperature is still not cool. Otherwise it may cause a swollen battery or even a fire hazard.
4. Please make sure that you use the original USB charging cable provided. When the battery has been used for along time, or appears to be swollen, please replace them.
5. A battery when not in use for along time will lose its charge automatically. Charging or discharging too often may reduce the life of the battery.

## BATTERY REPAIR & MAINTENANCE

1. Battery should be put in the dried or ventilated place with enviroment temperature about 18-25°C.
2. In order to enhance the using life of the battery, please avoid repeat charging or excessive discharging.
3. When the battery needs to be stored for a long time, please charge the battery first. That is to say, charge the battery for about 50%-60% of the volume and then well store it.
4. If you do not use it for more than 1 months, it s highly recommended that you need to check the battery voltage every month so as to make sure the voltage no less than 3V. Otherwise please do by following No.(3) mentioned.

## CONTROLLER MODES & INSTRUCTIONS

In order to adapt for more plays' operating habits, our controller sets three different speeds-Low/Medium/High Speed. Speed can be changed by pushing down button "5".

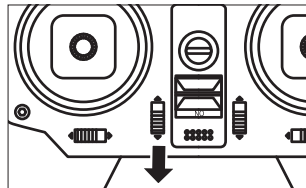

## OPERATING DIRECTION

### Hover up and down

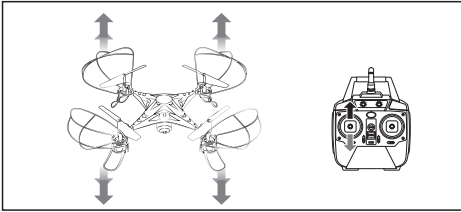

Push the throttle up or down, the quadcopter flies upward or downward.

### Forward and backward

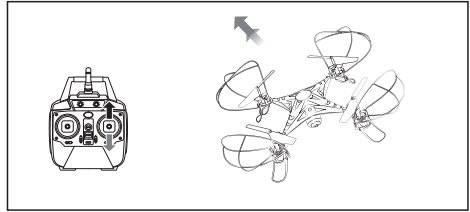

Push the direction lever up or down, the quadcopter flies forward or backward.

### Turn Left and Right

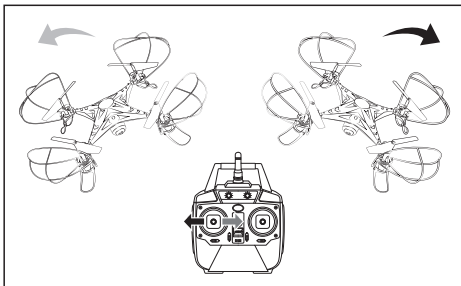

Pull the throttle left or right, the quadcopter turns to left or right.

### Sideward fly

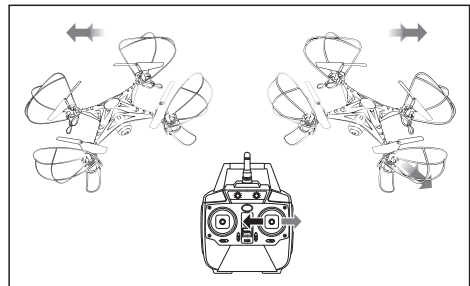

Pull the direction lever left or right, the quadcopter flies to left side or right side.

## FINE-TUNING OPERATION

### Forward/Backward fine-tuning

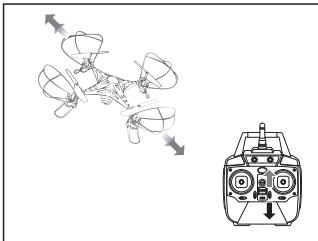

When the quadcopter keeps flying forward/backward, you can correct it by pressing fine-tuning button down/up.

### Sideward fly fine-tuning

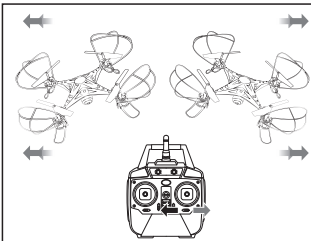

When the quadcopter keeps flying to left/right side, you can correct it by pressing the Fine-tuning button right/left.

### Turn left/right fine-tuning

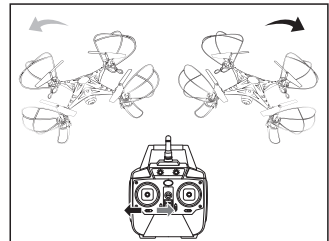

Turn left/right fine-tuning when the quadcopter keeps rotating to left /right, you can correct it by pressing the fine-tuning button right/left.

# INTRODUCTION TO QUADCOPTER FUNCTIONS

## Low-voltage protection:

When the quadcopter battery is not enough, the rotors will be stopped power supply. As the quadcopter control system will protect battery automatically.

## Over-current protection:

When the quadcopter's rotating blade is collided or jammed, the control system will stop supplying power for the rotors automatically. Then please re-match the signal for flying.

## Restart function:

In case of flight disorder or sideward flight, restore factory default settings by the following methods:

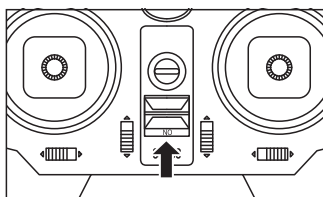

①. Press the power switch to turn on the transmitter.

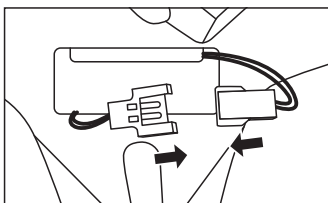

②. Connect the battery to the battery port.

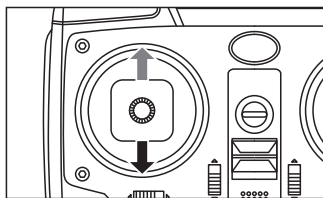

③. When the quadcopter indicator quickly flashing to slowly flashing, please push the throttle lever to the highest position, and then pull it back to the lowest position. Then the quadcopter indicator changed from slowly flashing to normal lights up.

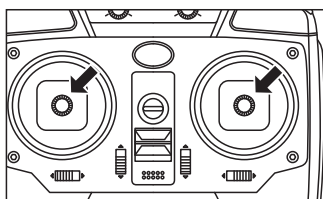

④. Place the quadcopter on a horizontal position, then push transmitter both left and right lever to lowest left corner for about 2-3 second, indicator on the quadcopter changed from normal lights up to quickly flashing; After 2-3 second, the indicator changed to normal lights, it means the quadcopter restarted /reset successfully.

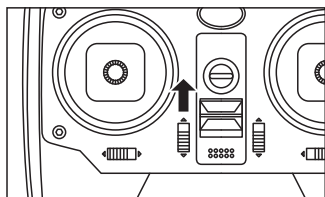

**Light Control Function:** The LED light on the product can be controlled by pushing up button "5". Push up this button at the first time, the light will be on. Push up again this button, the light will be off.

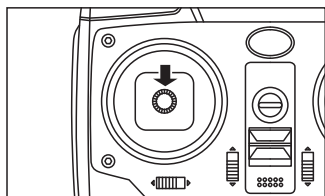

**Headless Mode Function:** Under normal control mode, player needs to discriminate front and back of the aircraft, then control forward and backward. Model equipped with headless mode, which is much easy for control. When headless mode was turn on, whatever which orientation the aircraft are, direction is decided by the direction you place when you turn on the quadcopter.

**How to turn on the headless mode:** Press down the left lever, the headless mode will be turn on, press down again the left control lever, the headless mode will be turn Off.

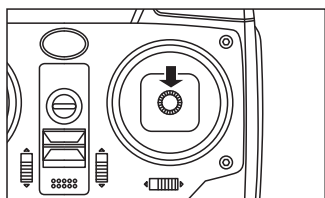

**Auto-return function :** When you want the aircraft to auto-return, please drive your aircraft in front of you, and press down the right control lever at once, when aircraft flying back, please keep controlling the up and down stick.

### 3D EVERSION AND THROWING FLIGHT INSTRUCTIONS

When you are familiar with the basic operation, you can do some awesome & exciting tricks and stunts! First of all, fly the aircraft to a height of more than 3 meters, press the 3D Eversion switch on the rear right side of the transmitter, then push the right rudder (in any direction) to make 360° degree flip.

**Tips:**  
3D eversion goes better when battery power is enough.

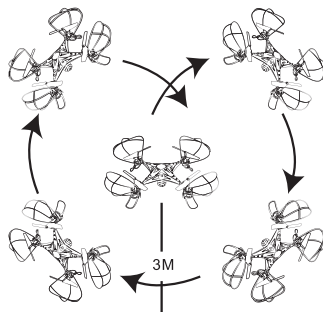

# TROUBLE SHOOTING

Problem	Reason	Solution
No response from the quadcopter	<ol style="list-style-type: none"> <li>1. Quadcopter battery power not enough;</li> <li>2. Transmitter battery power not enough;</li> <li>3. The band of the transmitter does not correspond to the decoding of the quadcopter.</li> </ol>	<ol style="list-style-type: none"> <li>1. Charge the quadcopter;</li> <li>2. Charge or replace them if required;</li> <li>3. Adjust the band on the transmitter and reeep it the same as the quacopter.</li> </ol>
If the quadcopter is slow to responc or difficult to Maneuver	<ol style="list-style-type: none"> <li>1. Insuffcient power with the transmitter;</li> <li>2. Transmitter of the same frequency is used nearby.</li> </ol>	<ol style="list-style-type: none"> <li>1. Replace the battery;</li> <li>2. Use the helicopter out of the range of other RC quadcopter.</li> </ol>

## MAIN PARAMETER

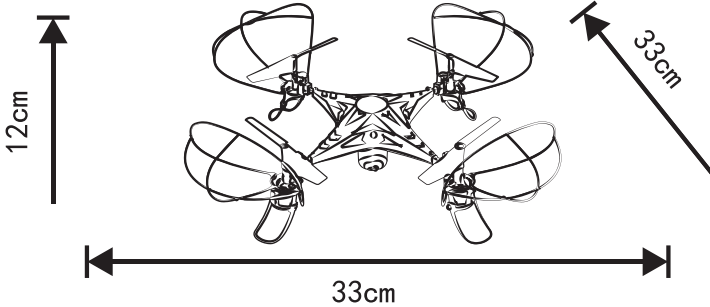

**Body length: 33cm**  
**Body width: 33cm**  
**Body high: 12cm**

**Main motor code: Ø8**  
**Battery: 3.7V 650 mAh Li-poly**

Tested to comply with FCC standards .

**FOR HOME OR OFFICE USE .**

This device complies with part 15 of the FCC

Rules .Operation is subject to the following two conditions :

- (1) This device may not cause harmful interference and
- (2) This device must accept any interference received , including interference that may cause undesired operation .

**SPECIFICATIONS AND COLORS OF CONTENTS MAY VARY FROM PHOTO.**

**WARNING:** Changes or modifications to this unit are not expressly approved by the party responsible for compliance and could void the user's authority to operate the equipment.

**NOTE:** This equipment has been tested and found to comply with the limits for a Class B digital device, pursuant to Part 15 of the FCC Rules. The limits are designed to provide reasonable protection against harmful interference in a residential installation. This equipment generates, uses and can radiate radio frequency energy and if not installed and used in accordance with the instructions, may cause harmful interference to radio communications.

However, there is no guarantee that interference will not occur in a particular installation. If this equipment does cause harmful interference to radio or television reception, which can be determined by turning the equipment off and on, the user is encouraged to try to correct the interference by one or more of the following measures:

- Reorient or relocate the receiving antenna.
- Increase the separation between the equipment and receiver.
- Connect the equipment into an outlet on a circuit different from that to which the receiver is connected.
- Consult the dealer or an experienced radio/TV technician for help.



FCC ID : 2ABDSBL-775-104

**MADE IN CHINA**

**WARNING:** Changes or modifications to this unit are not expressly approved by the party responsible for compliance and could void the user's authority to operate the equipment.

**NOTE:** This equipment has been tested and found to comply with the limits for a Class B digital device, pursuant to Part 15 of the FCC Rules. The limits are designed to provide reasonable protection against harmful interference in a residential installation. This equipment generates, uses and can radiate radio frequency energy and if not installed and used in accordance with the instructions, may cause harmful interference to radio communications.

However, there is no guarantee that interference will not occur in a particular installation. If this equipment does cause harmful interference to radio or television reception, which can be determined by turning the equipment off and on, the user is encouraged to try to correct the interference by one or more of the following measures:

- Reorient or relocate the receiving antenna.
- Increase the separation between the equipment and receiver.
- Connect the equipment into an outlet on a circuit different from that to which the receiver is connected.
- Consult the dealer or an experienced radio/TV technician for help.



FCC ID : 2ABDSBL-775-104

**MADE IN CHINA**

**WARNING:** Changes or modifications to this unit are not expressly approved by the party responsible for compliance and could void the user's authority to operate the equipment.

**NOTE:** This equipment has been tested and found to comply with the limits for a Class B digital device, pursuant to Part 15 of the FCC Rules. The limits are designed to provide reasonable protection against harmful interference in a residential installation. This equipment generates, uses and can radiate radio frequency energy and if not installed and used in accordance with the instructions, may cause harmful interference to radio communications.

However, there is no guarantee that interference will not occur in a particular installation. If this equipment does cause harmful interference to radio or television reception, which can be determined by turning the equipment off and on, the user is encouraged to try to correct the interference by one or more of the following measures:

- Reorient or relocate the receiving antenna.
- Increase the separation between the equipment and receiver.
- Connect the equipment into an outlet on a circuit different from that to which the receiver is connected.
- Consult the dealer or an experienced radio/TV technician for help.



FCC ID : 2ABDSBL-775-104

**MADE IN CHINA**



**WARNING:** Changes or modifications to this unit are not expressly approved by the party responsible for compliance and could void the user's authority to operate the equipment.

**NOTE:** This equipment has been tested and found to comply with the limits for a Class B digital device, pursuant to Part 15 of the FCC Rules. The limits are designed to provide reasonable protection against harmful interference in a residential installation. This equipment generates, uses and can radiate radio frequency energy and if not installed and used in accordance with the instructions, may cause harmful interference to radio communications.

However, there is no guarantee that interference will not occur in a particular installation. If this equipment does cause harmful interference to radio or television reception, which can be determined by turning the equipment off and on, the user is encouraged to try to correct the interference by one or more of the following measures:

- Reorient or relocate the receiving antenna.
- Increase the separation between the equipment and receiver.
- Connect the equipment into an outlet on a circuit different from that to which the receiver is connected.
- Consult the dealer or an experienced radio/TV technician for help.



FCC ID : 2ABDSBL-775-104

**MADE IN CHINA**

**WARNING:** Changes or modifications to this unit are not expressly approved by the party responsible for compliance and could void the user's authority to operate the equipment.

**NOTE:** This equipment has been tested and found to comply with the limits for a Class B digital device, pursuant to Part 15 of the FCC Rules. The limits are designed to provide reasonable protection against harmful interference in a residential installation. This equipment generates, uses and can radiate radio frequency energy and if not installed and used in accordance with the instructions, may cause harmful interference to radio communications.

However, there is no guarantee that interference will not occur in a particular installation. If this equipment does cause harmful interference to radio or television reception, which can be determined by turning the equipment off and on, the user is encouraged to try to correct the interference by one or more of the following measures:

- Reorient or relocate the receiving antenna.
- Increase the separation between the equipment and receiver.
- Connect the equipment into an outlet on a circuit different from that to which the receiver is connected.
- Consult the dealer or an experienced radio/TV technician for help.



FCC ID : 2ABDSBL-775-104

**MADE IN CHINA**

