



FCC TEST REPORT

Report No: STS1601038F02

Issued for

Borqs BeiJing Ltd.

Tower A, Building B23, Universal Business Park, No. 10
Jiuxianqiao Road, Chaoyang District Beijing, 100015 China

Product Name:	Tablet Remote
Brand Name:	VIZIO
Model Name:	XR6M
Series Model:	N/A
FCC ID:	2ABDK-XR6M
Test Standard:	FCC Part 15.407

Any reproduction of this document must be done in full. No single part of this document may be reproduced without permission from STS, All Test Data Presented in this report is only applicable to presented test sample.

Shenzhen STS Test Services Co., Ltd.
1/F., Building B, Zhuoke Science Park, No.190,Chongqing Road,
Fuyong Street, Bao'an District, Shenzhen, Guangdong,China
TEL: +86-755 3688 6288 FAX: +86-755 3688 6277 E-mail:sts@stsapp.com





TEST RESULT CERTIFICATION

Applicant's name : Borqs BeiJing Ltd.
 Address : Tower A, Building B23, Universal Business Park, No. 10
 Jiuxianqiao Road, Chaoyang District Beijing, 100015 China
Manufacture's Name..... : Borqs BeiJing Ltd.
 Address : Tower A, Building B23, Universal Business Park, No. 10
 Jiuxianqiao Road, Chaoyang District Beijing, 100015 China

Product description

Product name : Tablet Remote
 Model and/or type reference : XR6M
 Series Model..... : N/A

Standards : FCC Part15.407

Test procedure..... ANSI C63.10-2013

This device described above has been tested by STS, and the test results show that the equipment under test (EUT) is in compliance with the FCC&IC requirements. And it is applicable only to the tested sample identified in the report.

This report shall not be reproduced except in full, without the written approval of STS, this document may be altered or revised by STS, personal only, and shall be noted in the revision of the document.

Date of Test :
 Date (s) of performance of tests : 17 Feb. 2016 ~21 Mar. 2016
 Date of Issue..... : 22 Mar. 2016
 Test Result..... : **Pass**

Testing Engineer : 

 (Tony Liu)

Technical Manager : 

 (Vita Li)

Authorized Signatory : 

 (Bovey Yang)





Table of Contents	Page
1 . SUMMARY OF TEST RESULTS	7
1.1 TEST FACTORY	8
1.2 MEASUREMENT UNCERTAINTY	8
2 . GENERAL INFORMATION	9
2.1 GENERAL DESCRIPTION OF EUT	9
2.2 DESCRIPTION OF TEST MODES	11
2.3 BLOCK DIGRAM SHOWING THE CONFIGURATION OF SYSTEM TESTED	12
2.4 DESCRIPTION OF SUPPORT UNITS(CONDUCTED MODE)	13
2.5 EQUIPMENTS LIST FOR ALL TEST ITEMS	14
3 . EMC EMISSION TEST	15
3.1 CONDUCTED EMISSION MEASUREMENT	15
3.1.1 POWER LINE CONDUCTED EMISSION LIMITS	15
3.1.2 TEST PROCEDURE	16
3.1.3 DEVIATION FROM TEST STANDARD	16
3.1.4 TEST SETUP	16
3.1.5 EUT OPERATING CONDITIONS	16
3.1.6 TEST RESULTS	17
3.2 RADIATED EMISSION AND (UNWANTED EMISSIONS) MEASUREMENT	19
3.2.1 RADIATED EMISSION LIMITS	19
3.2.2 TEST PROCEDURE	20
3.2.3 DEVIATION FROM TEST STANDARD	20
3.2.4 TEST SETUP	21
3.2.5 EUT OPERATING CONDITIONS	21
3.2.6 TEST RESULTS (BETWEEN 9KHZ – 30 MHZ)	22
3.2.7 TEST RESULTS (BETWEEN 30MHZ – 1GHZ)	23
3.2.8 TEST RESULTS (ABOVE 1000 MHZ)	25
3.2.9 (BAND EDGE)	37
4. CONDUCTED SPURIOUS EMISSIONS	39
4.1 APPLIED PROCEDURES / LIMIT	39
4.1.1 TEST PROCEDURE	39
4.1.2 DEVIATION FROM STANDARD	39
4.1.3 TEST SETUP	39
4.1.4 EUT OPERATION CONDITIONS	39
4.1.5 TEST RESULTS	40
5. POWER SPECTRAL DENSITY TEST	56
5.1 APPLIED PROCEDURES / LIMIT	56
5.1.1 TEST PROCEDURE	56
5.1.2 DEVIATION FROM STANDARD	56



Table of Contents	Page
5.1.3 TEST SETUP	57
5.1.4 EUT OPERATION CONDITIONS	57
5.1.5 TEST RESULTS	58
6. BANDWIDTH MEASUREMENT	66
6.1 EMISSION BANDWIDTH (EBW) 26 BANDWID PROCEDURES / LIMIT	66
6.1.1 TEST PROCEDURE	66
6.1.2 DEVIATION FROM STANDARD	66
6.1.3 TEST SETUP	66
6.1.4 EUT OPERATION CONDITIONS	66
6.1.5 TEST RESULTS	67
6.2 OCCUPIED BANDWIDTH (99%) TEST APPLIED PROCEDURES / LIMIT	68
6.2.1 TEST PROCEDURE	68
6.2.2 DEVIATION FROM STANDARD	68
6.2.3 TEST SETUP	68
6.2.4 EUT OPERATION CONDITIONS	68
6.2.5 TEST RESULTS	69
6.3 MINIMUM EMISSION BANDWIDTH(6 DB) PROCEDURES / LIMIT	70
6.3.1 TEST PROCEDURE	70
6.3.2 DEVIATION FROM STANDARD	70
6.3.3 TEST SETUP	70
6.3.4 EUT OPERATION CONDITIONS	70
6.3.5 TEST RESULTS	71
6.4 BANDWIDTH TEST POLT	72
7. MAXIMUM CONDUCTED OUTPUT POWER	76
7.1 APPLIED PROCEDURES / LIMIT	76
7.1.1 TEST PROCEDURE	76
7.1.2 DEVIATION FROM STANDARD	76
7.1.3 TEST SETUP	77
7.1.4 EUT OPERATION CONDITIONS	77
7.1.5 TEST RESULTS	77
8. FREQUENCY STABILITY MEASUREMENT	78
8.1 LIMIT OF FREQUENCY STABILITY	78
8.1.1 MEASURING INSTRUMENTS	78
8.1.2 TEST PROCEDURES	78
8.1.3 TEST SETUP	78
8.1.4 TEST RESULTS	79
9. AUTOMATICALLY DISCONTINUE TRANSMISSION	81
9.1 LIMIT OF AUTOMATICALLY DISCONTINUE TRANSMISSION	81
9.2 TEST RESULT OF AUTOMATICALLY DISCONTINUE TRANSMISSION	81



Table of Contents	Page
10. ANTENNA REQUIREMENT	82
10.1 STANDARD REQUIREMENT	82
10.2 EUT ANTENNA	82
APPENDIX - PHOTOS OF TEST SETUP	83





Revision History

Rev.	Issue Date	Report NO.	Effect Page	Contents
00	22 Mar. 2016	STS1601038F02	ALL	Initial Issue





1. SUMMARY OF TEST RESULTS

Test procedures according to the technical standards:

§ 15.407, KDB 789033 D02 General UNII Test Procedures New Rules v01r01

FCC Part15 (15.407)		
FCC standard	Test Item	Judgment
15.207	AC Conducted Emission	PASS
§ 15.407 (2) (26 dB) / § 15.407 (e) (6 dB) / § 15.407 (a) (99%)	26dB/6dB &99% Bandwidth	PASS
15.407(a) (1).(2).(3).(4).(5)	Maximum Conducted Output Power	PASS
15.407(b)	Peak Excursion Ratio	PASS
15.407(b)& 15.209	Radiated Emission And (Unwanted Emissions) Measurement	PASS
15.407(b)7	Conducted Emission And (Unwanted Emissions) Measurement	PASS
15.407(a) (1).(2).(3).(4).(5)	Power Spectral Density	PASS
15.407(g)	Frequency Stability	PASS
15.407(c)	Automatically Discontinue Transmission	PASS
15.203/15.204	Antenna Requirement	PASS

NOTE:

(1) "N/A" denotes test is not applicable in this Test Report

(2) all tests are according to ANSI C63.10-2013



1.1 TEST FACTORY

Shenzhen STS Test Services Co., Ltd.
Add. : 1/F., Building B, Zhuoke Science Park, No.190,Chongqing Road,
Fuyong Street, Bao'an District, Shenzhen, Guangdong,China
CNAS Registration No.: L7649;
FCC Registration No.: 842334; IC Registration No.: 12108A-1

1.2 MEASUREMENT UNCERTAINTY

The reported uncertainty of measurement $y \pm U$, where expanded uncertainty U is based on a standard uncertainty multiplied by a coverage factor of $k=2$, providing a level of confidence of approximately **95 %**.

No.	Item	Uncertainty
1	Conducted Emission (9KHz-150KHz)	$\pm 2.88\text{dB}$
2	Conducted Emission (150KHz-30MHz)	$\pm 2.67\text{dB}$
3	RF power,conducted	$\pm 0.70\text{dB}$
4	Spurious emissions,conducted	$\pm 1.19\text{dB}$
5	All emissions,radiated(<1G) 30MHz-200MHz	$\pm 2.83\text{dB}$
6	All emissions,radiated(<1G) 200MHz-1000MHz	$\pm 2.94\text{dB}$
7	All emissions,radiated(>1G)	$\pm 3.03\text{dB}$
8	Temperature	$\pm 0.5^{\circ}\text{C}$
9	Humidity	$\pm 2\%$



2. GENERAL INFORMATION

2.1 GENERAL DESCRIPTION OF EUT

Equipment	Tablet Remote	
Trade Name	VIZIO	
Model Name	XR6M	
Series Model	N/A	
Model Difference	N/A	
Product Description	The EUT is a Tablet Remote	
	Operation Frequency:	IEEE 802.11a/ n(HT20) 5.180GHz-5.240GHz IEEE 802.11a/ n(HT20)5.745GHz-5.825GHz
	Modulation Type:	IEEE for 802.11a: OFDM(BPSK/QPSK/16QAM) IEEE for 802.11n : OFDM(BPSK/QPSK/16QAM)
	Bit Rate of Transmitter	802.11a:54/48/36/24/18/12/9/6Mbps 802.11n(20MHz):150/144.44/130/117/115.56/104/86.67/78/52/6.5 Mbps
	Antenna Designation:	See Note 3
	Max.Output Power(Conducted):	9.67dBm
	The duty cycle of WLAN 802.11a/n were 95 %	
	More details of EUT technical specification, please refer to the User's Manual.	
Test Channel	Please refer to the Note 2.	
Adapter	Input: AC100-240V, 450mA, 50/60 Hz Output: DC 3.7V, 2000mA	
Battery	Rated Voltage: 3.8V capacity :2740mAh	
Hardware version number	5.1.1	
Software version number	XR6M10.01	
Connecting I/O Port(s)	Please refer to the User's Manual	

Note:For a more detailed features description, please refer to the manufacturer's specifications or the User's Manual.



2. Operation Frequency of channel

5.180GHz-5.240GHz		5.745GHz-5.825GHz	
Channel	Frequency	Channel	Frequency
36	5180	149	5745
38	5190	151	5755
40	5200	153	5765
42	5210	157	5785
44	5220	159	5795
46	5230	161	5805
48	5240	165	5825

Note:

In section 15.31(m), regards to the operating frequency range over 10 MHz, the Lowest frequency, the middle frequency, and the highest frequency of channel were selected to perform the test, and the selected channel see below:

Carrier Frequency Channel

5GHz:

For 802.11a (HT20)

Channel	Freq.(MHz)	Channel	Freq.(MHz)
36	5180	149	5745
40	5200	157	5785
48	5240	165	5825

For 802.11n (HT20)

Channel	Freq.(MHz)	Channel	Freq.(MHz)
36	5180	149	5745
40	5200	157	5785
48	5240	165	5825

3. Table for Filed Antenna

Ant	Brand	Model Name	Antenna Type	Connector	Gain (dBi)	NOTE
A	VIZIO	XR6M	PIFA Antenna	N/A	-0.5	WIFI Antenna



2.2 DESCRIPTION OF TEST MODES

To investigate the maximum EMI emission characteristics generated from EUT, the test system was pre-scanning tested based on the consideration of following EUT operation mode or test configuration mode which possibly have effect on EMI emission level. Each of these EUT operation mode(s) or test configuration mode(s) mentioned above was evaluated respectively.

Pretest Mode	Description	Data Rate
Mode 1	TX IEEE 802.11a CH36&CH149	6 Mbps
Mode 2	TX IEEE 802.11a CH40&CH157	6 Mbps
Mode 3	TX IEEE 802.11 a CH48&CH165	6 Mbps
Mode 4	TX IEEE 802.11n HT20 CH36&CH149	MCS 0
Mode 5	TX IEEE 802.11n HT20 CH40&CH157	MCS 0
Mode 6	TX IEEE 802.11n HT20 CH48&CH165	MCS 0

Note:

- (1) The measurements are performed at the highest, middle, lowest available channels.
- (2) The measurements are performed at all Bit Rate of Transmitter, the worst data was reported
- (3) The EUT 's duty cycle is set to 100%

AC Conducted Emission

Test Case	
AC Conducted Emission	Mode 7: Keeping TX + WLAN Link + USB Cable (Charging from Adapter)

2.3 BLOCK DIGRAM SHOWING THE CONFIGURATION OF SYSTEM TESTED

Conducted Emission Test

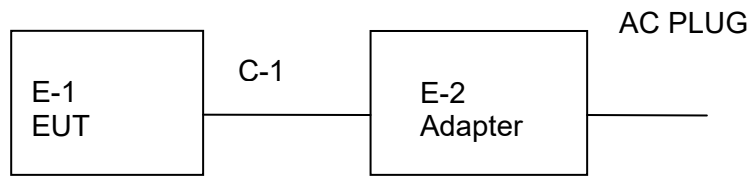

Radiated Spurious Emission Test

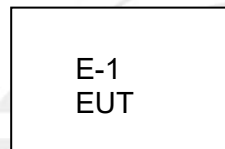



2.4 DESCRIPTION OF SUPPORT UNITS(CONDUCTED MODE)

The EUT has been tested as an independent unit together with other necessary accessories or support units. The following support units or accessories were used to form a representative test configuration during the tests.

Item	Equipment	Mfr/Brand	Model/Type No.	Series No.	Note
E-1	Tablet Remote	VIZIO	XR6M	N/A	EUT
E-2	Adapter	N/A	ASUC41a-050120	N/A	EUT
E-3	Earphone	N/A	N/A	N/A	N/A

Item	Shielded Type	Ferrite Core	Length	Note
C-1	USB Cable shielded line (Charging)	NO	100cm	N/A

Note:

- (1) The support equipment was authorized by Declaration of Confirmation.
- (2) For detachable type I/O cable should be specified the length in cm in 『Length』 column.
- (3) “YES” is means “shielded” “with core”; “NO” is means “unshielded” “without core”.

2.5 EQUIPMENTS LIST FOR ALL TEST ITEMS

Radiation Test equipment

Kind of Equipment	Manufacturer	Type No.	Serial No.	Last calibration	Calibrated until
Spectrum Analyzer	Agilent	E4407B	MY50140340	2015.10.25	2016.10.24
Test Receiver	R&S	ESCI	101427	2015.10.25	2016.10.24
Bilog Antenna	TESEQ	CBL6111D	34678	2015.11.25	2016.11.24
Horn Antenna	Schwarzbeck	BBHA 9120D	9120D-1343	2016.03.06	2017.03.05
Horn Antenna	Schwarzbeck	BBHA 9170	9170-0741	2016.03.06	2017.03.05
50Ω Coaxial Switch	Anritsu	MP59B	6200264416	2015.06.06	2016.06.05
PreAmplifier	Agilent	8449B	60538	2015.10.25	2016.10.24
Loop Antenna	ARA	PLA-1030/B	1029	2015.06.08	2016.06.07
Preamplifier	Agilent	8449B	60538	2015.11.05	2016.11.05
Low frequency cable	EM	R01	N/A	N/A	N/A
High frequency cable	SCHWARZBECK	AK9515H	SN-96286/96287	N/A	N/A

Conduction Test equipment

Kind of Equipment	Manufacturer	Type No.	Serial No.	Last calibration	Calibrated until
EMI Test Receiver	R&S	ESPI	102086	2015.11.20	2016.11.19
LISN	R&S	ENV216	101242	2015.10.25	2016.10.24
LISN	EMCO	3810/2NM	000-23625	2015.10.25	2016.10.24
Conduction Cable	EM	C01	N/A	N/A	N/A

RF Connected Test

Kind of Equipment	Manufacturer	Type No.	Serial No.	Last calibration	Calibrated until
USB RF power sensor	DARE	RPR3006W	15I00041SNO03	2015.10.25	2016.10.24
Spectrum Analyzer	Agilent	E4407B	MY50140340	2015.10.25	2016.10.24
Signal Analyzer	Agilent	N9020A	MY49100060	2015.11.18	2016.11.17

3. EMC EMISSION TEST

3.1 CONDUCTED EMISSION MEASUREMENT

3.1.1 POWER LINE CONDUCTED EMISSION Limits (Frequency Range 150KHz-30MHz)

FREQUENCY (MHz)	Class B (dBuV)		Standard
	Quasi-peak	Average	
0.15 -0.5	66 - 56 *	56 - 46 *	CISPR
0.50 -5.0	56.00	46.00	CISPR
5.0 -30.0	60.00	50.00	CISPR

0.15 -0.5	66 - 56 *	56 - 46 *	FCC
0.50 -5.0	56.00	46.00	FCC
5.0 -30.0	60.00	50.00	FCC

Note:

- (1) The tighter limit applies at the band edges.
- (2) The limit of " * " marked band means the limitation decreases linearly with the logarithm of the frequency in the range.

The following table is the setting of the receiver

Receiver Parameters	Setting
Attenuation	10 dB
Start Frequency	0.15 MHz
Stop Frequency	30 MHz
IF Bandwidth	9 kHz

3.1.2 TEST PROCEDURE

- a. The EUT was placed 0.4 meters from the horizontal ground plane with EUT being connected to the power mains through a line impedance stabilization network (LISN). All other support equipments powered from additional LISN(s). The LISN provide 50 Ohm/ 50uH of coupling impedance for the measuring instrument.
- b. Interconnecting cables that hang closer than 40 cm to the ground plane shall be folded back and forth in the center forming a bundle 30 to 40 cm long.
- c. I/O cables that are not connected to a peripheral shall be bundled in the center. The end of the cable may be terminated, if required, using the correct terminating impedance. The overall length shall not exceed 1 m.
- d. LISN at least 80 cm from nearest part of EUT chassis.
- e. For the actual test configuration, please refer to the related Item –EUT Test Photos.

3.1.3 DEVIATION FROM TEST STANDARD

No deviation

3.1.4 TEST SETUP

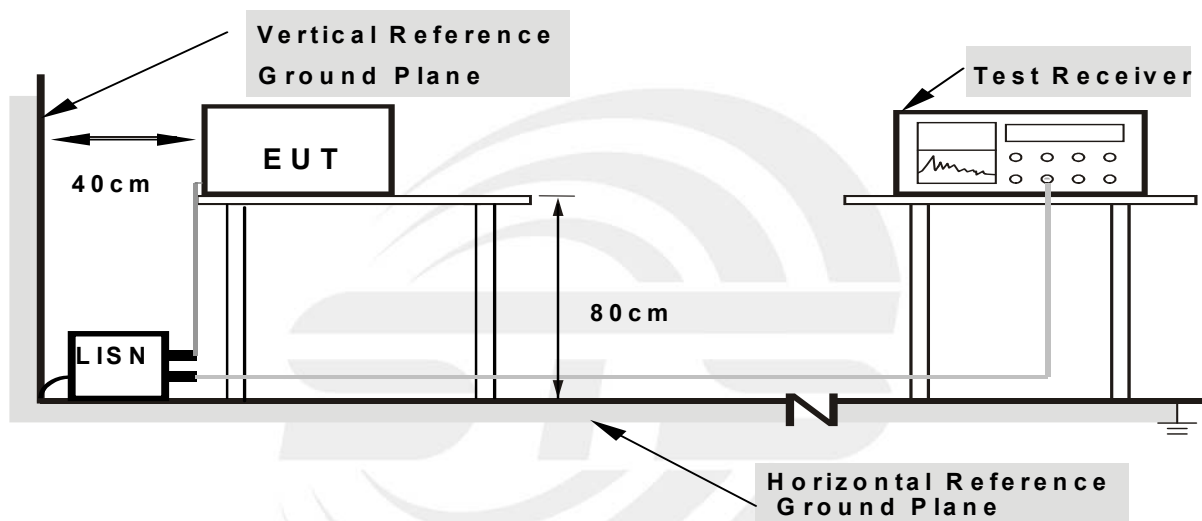

- Note:**
- 1. Support units were connected to second LISN.
 - 2. Both of LISNs (AMN) are 80 cm from EUT and at least 80 from other units and other metal planes

3.1.5 EUT OPERATING CONDITIONS

The EUT was configured for testing in a typical fashion (as a customer would normally use it). The EUT has been programmed to continuously transmit during test. This operating condition was tested and used to collect the included data.



3.1.6 TEST RESULTS

Temperature:	26 °C	Relative Humidity:	54%
Pressure:	1010hPa	Phase:	L
Test Voltage :	AC 120V/50Hz	Test Mode :	Mode 7

No.	Frequency (MHz)	Reading (dBuV)	Factor (dB)	Result (dBuV)	Limit (dBuV/m)	Margin (dB)	Detector
1	0.4340	37.23	10.10	47.33	57.18	-9.85	QP
2	0.4340	31.10	10.10	41.20	47.18	-5.98	AVG
3	0.5060	34.47	9.90	44.37	56.00	-11.63	QP
4	0.5060	25.09	9.90	34.99	46.00	-11.01	AVG
5	0.5780	38.01	9.94	47.95	56.00	-8.05	QP
6	0.5780	32.04	9.94	41.98	46.00	-4.02	AVG
7	0.7260	38.74	9.99	48.73	56.00	-7.27	QP
8	0.7260	30.11	9.99	40.10	46.00	-5.90	AVG
9	0.8740	36.11	9.94	46.05	56.00	-9.95	QP
10	0.8740	27.73	9.94	37.67	46.00	-8.33	AVG
11	1.5220	38.05	9.95	48.00	56.00	-8.00	QP
12	1.5220	28.38	9.95	38.33	46.00	-7.67	AVG

Remark:

1. All readings are Quasi-Peak and Average values.
2. Factor = Insertion Loss + Cable Loss.
3. N/A means All Data have pass Limit

100.0 dBuV

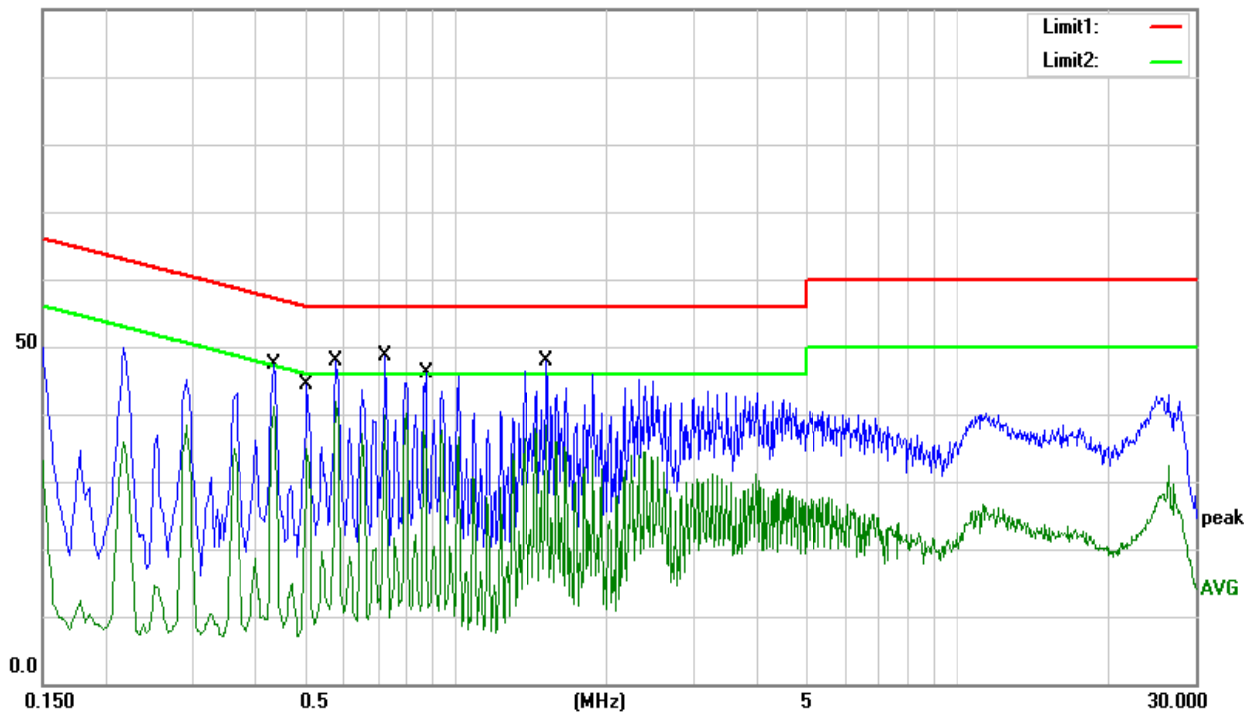



Temperature:	26 °C	Relative Humidity:	54%
Pressure:	1010hPa	Phase:	N
Test Voltage	AC 120V/50Hz	Test Mode	Mode 7

No.	Frequency (MHz)	Reading (dBuV)	Factor (dB)	Result (dBuV)	Limit (dBuV/m)	Margin (dB)	Detector
1	0.4380	34.28	9.96	44.24	57.10	-12.86	QP
2	0.4380	29.53	9.96	39.49	47.10	-7.61	AVG
3	0.5820	34.90	9.94	44.84	56.00	-11.16	QP
4	0.5820	29.97	9.94	39.91	46.00	-6.09	AVG
5	0.7300	33.74	10.00	43.74	56.00	-12.26	QP
6	0.7300	27.19	10.00	37.19	46.00	-8.81	AVG
7	0.8740	32.51	10.00	42.51	56.00	-13.49	QP
8	0.8740	25.19	10.00	35.19	46.00	-10.81	AVG
9	1.5300	32.52	10.00	42.52	56.00	-13.48	QP
10	1.5300	25.05	10.00	35.05	46.00	-10.95	AVG
11	2.2620	31.66	10.00	41.66	56.00	-14.34	QP
12	2.2620	21.75	10.00	31.75	46.00	-14.25	AVG

Remark:

1. All readings are Quasi-Peak and Average values.
2. Factor = Insertion Loss + Cable Loss.
3. N/A means All Data have pass Limit

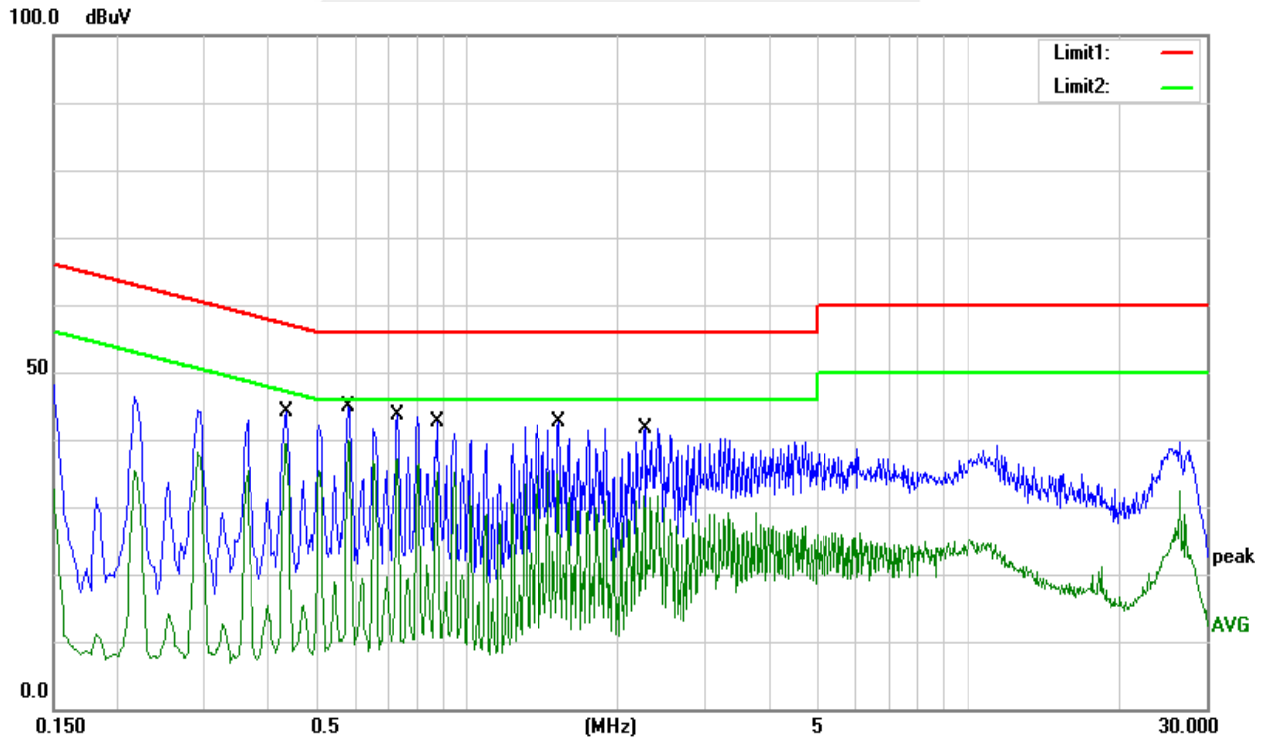

3.2 RADIATED EMISSION AND (UNWANTED EMISSIONS) MEASUREMENT

3.2.1 RADIATED EMISSION LIMITS (Frequency Range 9kHz-1000MHz)

20dBc in any 100 kHz bandwidth outside the operating frequency band. In case the emission fall within the restricted band specified on 15.407(b)7& 15.205/209(a), then the (a); limit in the table below has to be followed.

Frequencies (MHz)	Field Strength (microvolts/meter)	Measurement Distance (meters)
0.009~0.490	2400/F(KHz)	300
0.490~1.705	24000/F(KHz)	30
1.705~30.0	30	30
30~88	100	3
88~216	150	3
216~960	200	3
Above 960	500	3

LIMITS OF RADIATED EMISSION MEASUREMENT (Above 1000MHz)

FREQUENCY (MHz)	Class B (dBuV/m) (at 3M)	
	PEAK	AVERAGE
Above 1000	74	54

Notes:

- (1) The limit for radiated test was performed according to FCC PART 15E.
- (2) The tighter limit applies at the band edges.
- (3) Emission level (dBuV/m)=20log Emission level (uV/m).

Spectrum Parameter	Setting
Attenuation	Auto
Detector	Peak
Start Frequency	1000 MHz(Peak/AV)
Stop Frequency	10th carrier harmonic(Peak/AV)
RB / VB (emission in restricted band)	1 MHz / 1 MHz, AV=1 MHz /3 MHz

For Band edge

Spectrum Parameter	Setting
Detector	Peak
Start/Stop Frequency	Lower Band Edge: 5130 to 5370 MHz Upper Band Edge: 5705 to 5880 MHz
RB / VB (emission in restricted band)	1 MHz / 1 MHz, AV=1 MHz /10 Hz



Receiver Parameter	Setting
Attenuation	Auto
Start ~ Stop Frequency	9kHz~90kHz / RB 200Hz for PK & AV
Start ~ Stop Frequency	90kHz~110kHz / RB 200Hz for QP
Start ~ Stop Frequency	110kHz~490kHz / RB 200Hz for PK & AV
Start ~ Stop Frequency	490kHz~30MHz / RB 9kHz for QP
Start ~ Stop Frequency	30MHz~1000MHz / RB 120kHz for QP

3.2.2 TEST PROCEDURE

- The measuring distance of at 3 m shall be used for measurements at frequency up to 1GHz. For frequencies above 1GHz, any suitable measuring distance may be used.
- The EUT was placed on the top of a rotating table 0.8 meters above the ground at a 3 meter anechoic chamber test site. The table was rotated 360 degrees to determine the position of the highest radiation.
- The height of the equipment or of the substitution antenna shall be 0.8 m; the height of the test antenna shall vary between 1 m to 4 m. Both horizontal and vertical polarizations of the antenna are set to make the measurement.
- The initial step in collecting conducted emission data is a spectrum analyzer peak detector mode pre-scanning the measurement frequency range. Significant peaks are then marked and then Quasi Peak detector mode re-measured.
- If the Peak Mode measured value compliance with and lower than Quasi Peak Mode Limit, the EUT shall be deemed to meet QP Limits and then no additional QP Mode measurement performed.
- For the actual test configuration, please refer to the related Item –EUT Test Photos.

Note:

Both horizontal and vertical antenna polarities were tested and performed pretest to three orthogonal axis. The worst case emissions were reported

3.2.3 DEVIATION FROM TEST STANDARD

No deviation

3.2.4 TEST SETUP

(A) Radiated Emission Test-Up Frequency Below 30MHz

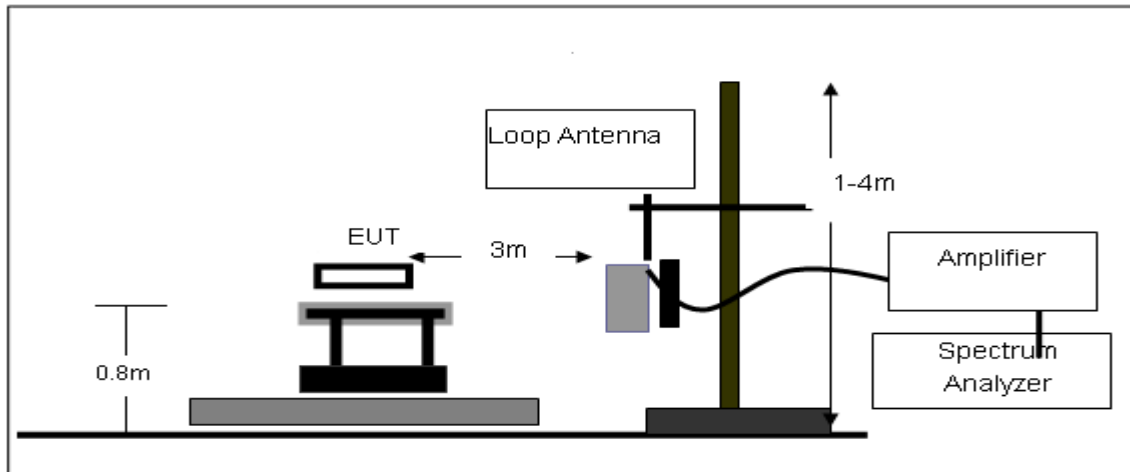

(B) Radiated Emission Test-Up Frequency 30MHz~1GHz

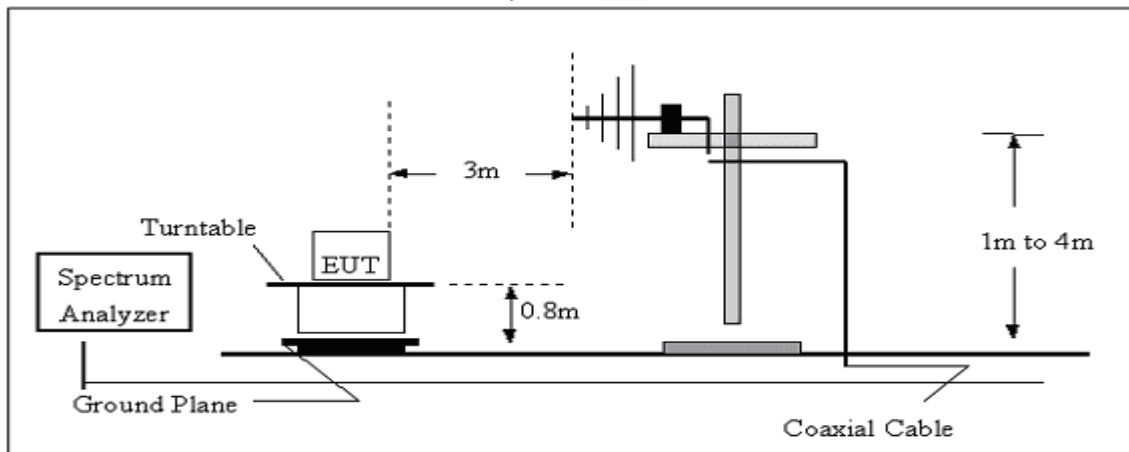

(C) Radiated Emission Test-Up Frequency Above 1GHz

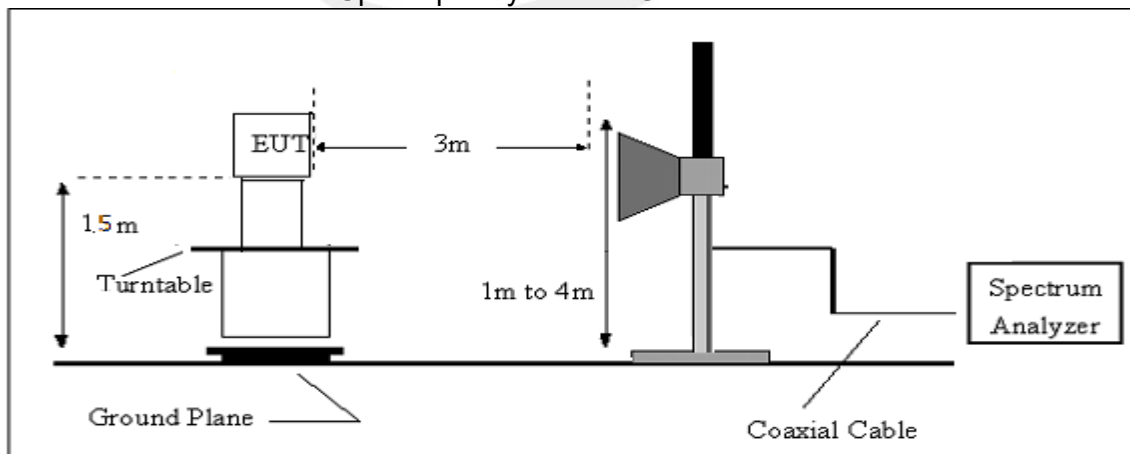

3.2.5 EUT OPERATING CONDITIONS

The EUT tested system was configured as the statements of 2.4 Unless otherwise a special operating condition is specified in the follows during the testing.

**3.2.6 TEST RESULTS (BETWEEN 9KHZ – 30 MHZ)**

Temperature:	20 °C	Relative Humidity:	48%
Pressure:	1010 hPa	Test Voltage :	DC 3.8V from Battery
Test Mode :	TX Mode	Polarization :	--

Freq. (MHz)	Reading (dBuV/m)	Limit (dBuV/m)	Margin (dB)	State P/F
--	--	--	--	PASS
--	--	--	--	PASS

NOTE:

The amplitude of spurious emissions which are attenuated by more than 20dB below the permissible value has no need to be reported.

Distance extrapolation factor = $40 \log(\text{specific distance}/\text{test distance})$ (dB);

Limit line = specific limits(dBuV) + distance extrapolation factor.



3.2.7 TEST RESULTS (BETWEEN 30MHZ – 1GHZ)

Temperature	26 °C	Relative Humidity	48%
Pressure	1010 hPa	Test Voltage	DC 3.8V
Test Mode	(Mode 1-6M worst mode)	Polarization	Horizontal

No.	Frequency (MHz)	Reading (dBuV)	Factor (dB)	Results (dBuV/m)	Limit (dBuV/m)	Margin (dB)	Detector
1	30.9620	6.21	18.21	24.42	40.00	-15.58	QP
2	47.9940	11.91	9.16	21.07	40.00	-18.93	QP
3	99.1797	11.67	10.60	22.27	43.50	-21.23	QP
4	134.5592	10.39	11.95	22.34	43.50	-21.16	QP
5	169.5990	11.15	10.58	21.73	43.50	-21.77	QP
6	255.6231	8.95	14.48	23.43	46.00	-22.57	QP

Remark:

1. All readings are Quasi-Peak and Average values.
2. Factor = Antenna Factor + Cable Loss.
3. N/A means All Data have pass Limit

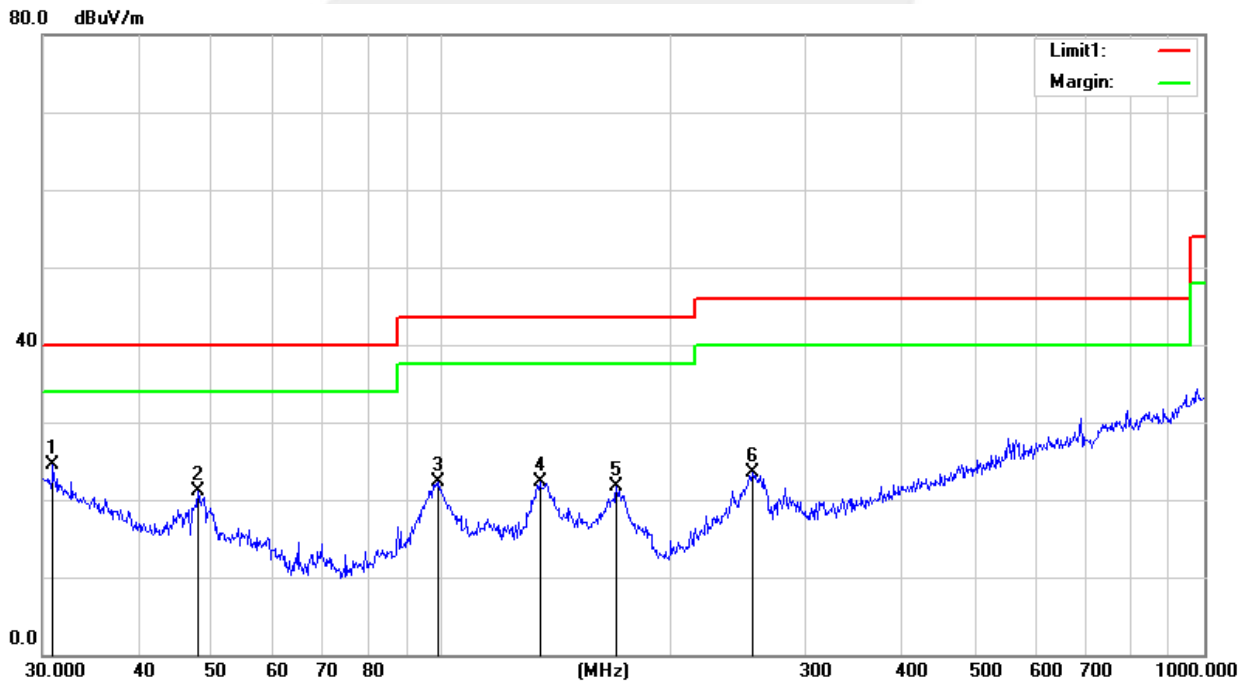



Temperature	26 °C	Relative Humidity	48%
Pressure	1010 hPa	Test Voltage	DC 3.8V
Test Mode	(Mode 1-6M worst mode)	Polarization	Vertical

No.	Frequency (MHz)	Reading (dBuV)	Factor (dB)	Results (dBuV/m)	Limit (dBuV/m)	Margin (dB)	Detector
1	30.0000	13.13	18.71	31.84	40.00	-8.16	QP
2	48.8430	22.12	8.71	30.83	40.00	-9.17	QP
3	87.7248	13.49	9.19	22.68	40.00	-17.32	QP
4	135.9822	11.69	12.54	24.23	43.50	-19.27	QP
5	164.3301	13.28	11.11	24.39	43.50	-19.11	QP
6	256.5211	7.57	14.57	22.14	46.00	-23.86	QP

Remark:

1. All readings are Quasi-Peak and Average values.
2. Factor = Antenna Factor + Cable Loss.
3. N/A means All Data have pass Limit

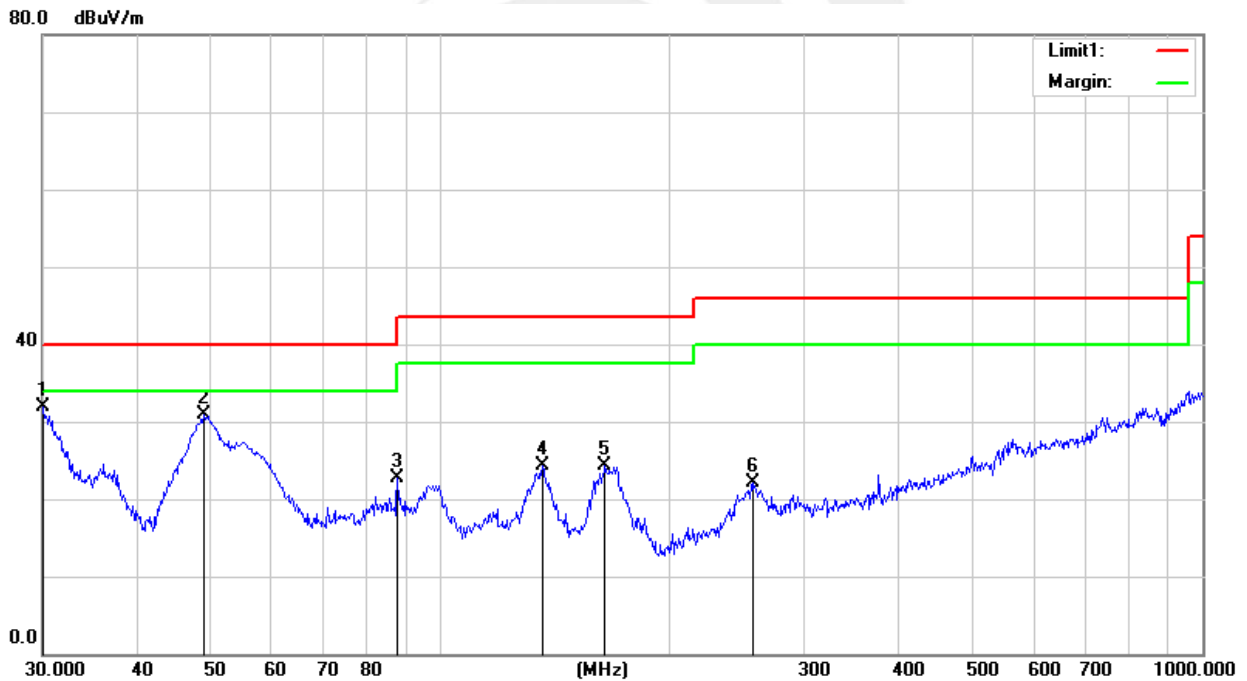



3.2.8 TEST RESULTS (ABOVE 1000 MHZ)

(worst mode)

Band I(5.15-5.25) GHz

Low Channel (802.11/ 5180 MHz)

Frequency	Meter Reading	Factor	Emission Level	Limits	Margin	Detector	Comment
(MHz)	(dBμV)	(dB)	(dBμV/m)	(dBμV/m)	(dB)	Type	
3265.26	45.17	-9.80	35.37	74.00	-38.63	Pk	Vertical
3265.21	45.18	-9.80	35.38	54.00	-18.62	AV	Vertical
3265.21	45.16	-9.80	35.36	74.00	-38.64	Pk	Horizontal
3265.26	45.16	-9.80	35.36	54.00	-18.64	AV	Horizontal
3334.84	42.90	-9.75	33.15	74.00	-40.85	Pk	Vertical
3335.04	42.95	-9.75	33.20	54.00	-20.80	AV	Vertical
3334.83	42.94	-9.75	33.19	74.00	-40.81	Pk	Horizontal
3335.03	42.94	-9.75	33.19	54.00	-20.81	AV	Horizontal
3349.87	42.68	-9.75	32.93	74.00	-41.07	Pk	Vertical
3349.97	42.68	-9.75	32.93	54.00	-21.07	AV	Vertical
3349.88	42.72	-9.75	32.97	74.00	-41.03	Pk	Horizontal
3349.93	42.69	-9.75	32.94	54.00	-21.06	AV	Horizontal
4000.21	40.08	-6.60	33.48	74.00	-40.52	Pk	Vertical
4000.09	40.07	-6.60	33.47	54.00	-20.53	AV	Vertical
4000.2	40.04	-6.60	33.44	74.00	-40.56	Pk	Horizontal
4000.07	40.07	-6.60	33.47	54.00	-20.53	AV	Horizontal
5360.18	38.39	-2.34	36.05	74.00	-37.95	Pk	Vertical
5360.09	38.44	-2.34	36.10	54.00	-17.90	AV	Vertical
5360.21	38.41	-2.34	36.07	74.00	-37.93	Pk	Horizontal
5360.06	38.40	-2.34	36.06	54.00	-17.94	AV	Horizontal
7236.28	37.86	3.40	41.26	74.00	-32.74	Pk	Vertical
7236.33	37.86	3.40	41.26	54.00	-12.74	AV	Vertical
7236.31	37.86	3.40	41.26	74.00	-32.74	Pk	Horizontal
7236.32	37.88	3.40	41.28	54.00	-12.72	AV	Horizontal
8124.41	36.31	4.80	41.11	74.00	-32.89	Pk	Vertical
8124.44	36.29	4.80	41.09	54.00	-12.91	AV	Vertical
8124.43	36.31	4.80	41.11	74.00	-32.89	Pk	Horizontal
8124.44	36.36	4.80	41.16	54.00	-12.84	AV	Horizontal
9105.12	35.15	5.00	40.15	74.00	-33.85	Pk	Vertical
9105.26	35.10	5.00	40.10	54.00	-13.90	AV	Vertical
9105.15	35.13	5.00	40.13	74.00	-33.87	Pk	Horizontal



9105.22	35.10	5.00	40.10	54.00	-13.90	AV	Horizontal
10360.33	40.13	10.20	50.33	74.00	-23.67	Pk	Vertical
10360.54	40.08	10.20	50.28	54.00	-3.72	AV	Vertical
10360.36	40.08	10.20	50.28	74.00	-23.72	Pk	Horizontal
10360.53	40.09	10.20	50.29	54.00	-3.71	AV	Horizontal
11036.34	34.14	10.20	44.34	74.00	-29.66	Pk	Vertical
11036.54	34.09	10.20	44.29	54.00	-9.71	AV	Vertical
11036.36	34.08	10.20	44.28	74.00	-29.72	Pk	Horizontal
11036.56	34.10	10.20	44.30	54.00	-9.70	AV	Horizontal
13299.88	32.93	12.20	45.13	74.00	-28.87	Pk	Vertical
13299.82	32.98	12.20	45.18	54.00	-8.82	AV	Vertical
13299.87	32.98	12.20	45.18	74.00	-28.82	Pk	Horizontal
13299.88	32.96	12.20	45.16	54.00	-8.84	AV	Horizontal
14480.19	31.87	13.40	45.27	74.00	-28.73	Pk	Vertical
14480.36	31.90	13.40	45.30	54.00	-8.70	AV	Vertical
14480.21	31.86	13.40	45.26	74.00	-28.74	Pk	Horizontal
14480.36	31.90	13.40	45.30	54.00	-8.70	AV	Horizontal
15540.23	35.85	13.40	49.25	74.00	-24.75	Pk	Vertical
15540.37	35.88	13.40	49.28	54.00	-4.72	AV	Vertical
15540.21	35.84	13.40	49.24	74.00	-24.76	Pk	Horizontal
15540.35	35.89	13.40	49.29	54.00	-4.71	AV	Horizontal
16000.24	31.04	12.40	43.44	74.00	-30.56	Pk	Vertical
16000.31	30.94	12.40	43.34	54.00	-10.66	AV	Vertical
16000.19	30.97	12.40	43.37	74.00	-30.63	Pk	Horizontal
16000.32	30.97	12.40	43.37	54.00	-10.63	AV	Horizontal
17998.31	28.16	23.10	51.26	74.00	-22.74	Pk	Vertical
17998.15	28.14	23.10	51.24	54.00	-2.76	AV	Vertical
17998.18	28.16	23.10	51.26	74.00	-22.74	Pk	Horizontal
17998.06	28.17	23.10	51.27	54.00	-2.73	AV	Horizontal



Mid Channel (802.11/ 5200 MHz)

Frequency	Meter Reading	Factor	Emission Level	Limits	Margin	Detector	Comment
(MHz)	(dB μ V)	(dB)	(dB μ V/m)	(dB μ V/m)	(dB)	Type	
3265.25	45.18	-9.80	35.38	74.00	-38.62	Pk	Vertical
3265.24	45.18	-9.80	35.38	54.00	-18.62	AV	Vertical
3265.22	45.15	-9.80	35.35	74.00	-38.65	Pk	Horizontal
3265.26	45.15	-9.80	35.35	54.00	-18.65	AV	Horizontal
3334.85	42.93	-9.75	33.18	74.00	-40.82	Pk	Vertical
3335.02	42.92	-9.75	33.17	54.00	-20.83	AV	Vertical
3334.82	42.95	-9.75	33.20	74.00	-40.80	Pk	Horizontal
3335.04	42.96	-9.75	33.21	54.00	-20.79	AV	Horizontal
3349.88	42.70	-9.75	32.95	74.00	-41.05	Pk	Vertical
3349.97	42.69	-9.75	32.94	54.00	-21.06	AV	Vertical
3349.89	42.72	-9.75	32.97	74.00	-41.03	Pk	Horizontal
3349.95	42.69	-9.75	32.94	54.00	-21.06	AV	Horizontal
4000.23	40.07	-6.60	33.47	74.00	-40.53	Pk	Vertical
4000.09	40.06	-6.60	33.46	54.00	-20.54	AV	Vertical
4000.21	40.08	-6.60	33.48	74.00	-40.52	Pk	Horizontal
4000.11	40.04	-6.60	33.44	54.00	-20.56	AV	Horizontal
5360.20	38.41	-2.34	36.07	74.00	-37.93	Pk	Vertical
5360.12	38.44	-2.34	36.10	54.00	-17.90	AV	Vertical
5360.20	38.40	-2.34	36.06	74.00	-37.94	Pk	Horizontal
5360.07	38.38	-2.34	36.04	54.00	-17.96	AV	Horizontal
7236.28	37.86	3.40	41.26	74.00	-32.74	Pk	Vertical
7236.33	37.84	3.40	41.24	54.00	-12.76	AV	Vertical
7236.34	37.87	3.40	41.27	74.00	-32.73	Pk	Horizontal
7236.36	37.85	3.40	41.25	54.00	-12.75	AV	Horizontal
8124.41	36.34	4.80	41.14	74.00	-32.86	Pk	Vertical
8124.41	36.31	4.80	41.11	54.00	-12.89	AV	Vertical
8124.41	36.31	4.80	41.11	74.00	-32.89	Pk	Horizontal
8124.45	36.34	4.80	41.14	54.00	-12.86	AV	Horizontal
9105.09	35.15	5.00	40.15	74.00	-33.85	Pk	Vertical
9105.23	35.11	5.00	40.11	54.00	-13.89	AV	Vertical
9105.12	35.14	5.00	40.14	74.00	-33.86	Pk	Horizontal
9105.22	35.13	5.00	40.13	54.00	-13.87	AV	Horizontal
10400.37	40.12	10.20	50.32	74.00	-23.68	Pk	Vertical



10400.55	40.12	10.20	50.32	54.00	-3.68	AV	Vertical
10400.35	40.10	10.20	50.30	74.00	-23.70	Pk	Horizontal
10400.55	40.10	10.20	50.30	54.00	-3.70	AV	Horizontal
11036.35	34.11	10.20	44.31	74.00	-29.69	Pk	Vertical
11036.55	34.10	10.20	44.30	54.00	-9.70	AV	Vertical
11036.35	34.11	10.20	44.31	74.00	-29.69	Pk	Horizontal
11036.56	34.08	10.20	44.28	54.00	-9.72	AV	Horizontal
13299.87	32.92	12.20	45.12	74.00	-28.88	Pk	Vertical
13299.87	32.97	12.20	45.17	54.00	-8.83	AV	Vertical
13299.88	32.96	12.20	45.16	74.00	-28.84	Pk	Horizontal
13299.90	32.96	12.20	45.16	54.00	-8.84	AV	Horizontal
14480.24	31.83	13.40	45.23	74.00	-28.77	Pk	Vertical
14480.37	31.90	13.40	45.30	54.00	-8.70	AV	Vertical
14480.23	31.83	13.40	45.23	74.00	-28.77	Pk	Horizontal
14480.36	31.88	13.40	45.28	54.00	-8.72	AV	Horizontal
15600.20	35.84	13.40	49.24	74.00	-24.76	Pk	Vertical
15600.25	35.88	13.40	49.28	54.00	-4.72	AV	Vertical
15600.21	35.85	13.40	49.25	74.00	-24.75	Pk	Horizontal
15600.36	35.88	13.40	49.28	54.00	-4.72	AV	Horizontal
16000.24	31.01	12.40	43.41	74.00	-30.59	Pk	Vertical
16000.30	30.95	12.40	43.35	54.00	-10.65	AV	Vertical
16000.22	30.99	12.40	43.39	74.00	-30.61	Pk	Horizontal
16000.30	30.97	12.40	43.37	54.00	-10.63	AV	Vertical
17998.31	28.16	23.10	51.26	74.00	-22.74	Pk	Vertical
17998.16	28.15	23.10	51.25	54.00	-2.75	AV	Horizontal
17998.17	28.16	23.10	51.26	74.00	-22.74	Pk	Vertical
17998.09	28.19	23.10	51.29	54.00	-2.71	AV	Horizontal



High Channel (802.11/ 5240 MHz)

Frequency	Meter Reading	Factor	Emission Level	Limits	Margin	Detector	Comment
(MHz)	(dBμV)	(dB)	(dBμV/m)	(dBμV/m)	(dB)	Type	
3265.25	45.19	-9.80	35.39	74.00	-38.61	Pk	Vertical
3265.21	45.14	-9.80	35.34	54.00	-18.66	AV	Vertical
3265.22	45.17	-9.80	35.37	74.00	-38.63	Pk	Horizontal
3265.26	45.17	-9.80	35.37	54.00	-18.63	AV	Horizontal
3334.82	42.93	-9.75	33.18	74.00	-40.82	Pk	Vertical
3335.05	42.94	-9.75	33.19	54.00	-20.81	AV	Vertical
3334.84	42.91	-9.75	33.16	74.00	-40.84	Pk	Horizontal
3335.04	42.96	-9.75	33.21	54.00	-20.79	AV	Horizontal
3349.84	42.69	-9.75	32.94	74.00	-41.06	Pk	Vertical
3349.99	42.70	-9.75	32.95	54.00	-21.05	AV	Vertical
3349.88	42.74	-9.75	32.99	74.00	-41.01	Pk	Horizontal
3349.94	42.73	-9.75	32.98	54.00	-21.02	AV	Horizontal
4000.22	40.05	-6.60	33.45	74.00	-40.55	Pk	Vertical
4000.08	40.09	-6.60	33.49	54.00	-20.51	AV	Vertical
4000.22	40.06	-6.60	33.46	74.00	-40.54	Pk	Horizontal
4000.08	40.03	-6.60	33.43	54.00	-20.57	AV	Horizontal
5360.21	38.38	-2.34	36.04	74.00	-37.96	Pk	Vertical
5360.08	38.40	-2.34	36.06	54.00	-17.94	AV	Vertical
5360.21	38.37	-2.34	36.03	74.00	-37.97	Pk	Horizontal
5360.06	38.38	-2.34	36.04	54.00	-17.96	AV	Horizontal
7236.26	37.85	3.40	41.25	74.00	-32.75	Pk	Vertical
7236.34	37.86	3.40	41.26	54.00	-12.74	AV	Vertical
7236.34	37.87	3.40	41.27	74.00	-32.73	Pk	Horizontal
7236.34	37.88	3.40	41.28	54.00	-12.72	AV	Horizontal
8124.40	36.35	4.80	41.15	74.00	-32.85	Pk	Vertical
8124.43	36.32	4.80	41.12	54.00	-12.88	AV	Vertical
8124.43	36.30	4.80	41.10	74.00	-32.90	Pk	Horizontal
8124.45	36.31	4.80	41.11	54.00	-12.89	AV	Horizontal
9105.11	35.15	5.00	40.15	74.00	-33.85	Pk	Vertical
9105.21	35.12	5.00	40.12	54.00	-13.88	AV	Vertical
9105.13	35.12	5.00	40.12	74.00	-33.88	Pk	Horizontal
9105.19	35.13	5.00	40.13	54.00	-13.87	AV	Horizontal
10800.37	40.12	10.20	50.32	74.00	-23.68	Pk	Vertical
10800.55	40.12	10.20	50.32	54.00	-3.68	AV	Vertical
10800.38	40.11	10.20	50.31	74.00	-23.69	Pk	Horizontal



10800.52	40.11	10.20	50.31	54.00	-3.69	AV	Horizontal
11036.36	34.11	10.20	44.31	74.00	-29.69	Pk	Vertical
11036.52	34.13	10.20	44.33	54.00	-9.67	AV	Vertical
11036.34	34.08	10.20	44.28	74.00	-29.72	Pk	Horizontal
11036.55	34.11	10.20	44.31	54.00	-9.69	AV	Horizontal
13299.88	32.95	12.20	45.15	74.00	-28.85	Pk	Vertical
13299.82	32.95	12.20	45.15	54.00	-8.85	AV	Vertical
13299.86	32.96	12.20	45.16	74.00	-28.84	Pk	Horizontal
13299.87	32.94	12.20	45.14	54.00	-8.86	AV	Horizontal
14480.24	31.84	13.40	45.24	74.00	-28.76	Pk	Vertical
14480.36	31.88	13.40	45.28	54.00	-8.72	AV	Vertical
14480.19	31.85	13.40	45.25	74.00	-28.75	Pk	Horizontal
14480.37	31.89	13.40	45.29	54.00	-8.71	AV	Horizontal
16000.22	31.02	12.40	43.42	74.00	-30.58	Pk	Vertical
16000.28	30.96	12.40	43.36	54.00	-10.64	AV	Vertical
16000.23	30.97	12.40	43.37	74.00	-30.63	Pk	Horizontal
16000.31	30.99	12.40	43.39	54.00	-10.61	AV	Horizontal
16200.23	31.03	12.40	43.43	74.00	-30.57	Pk	Vertical
16200.31	30.96	12.40	43.36	54.00	-10.64	AV	Vertical
16200.20	30.99	12.40	43.39	74.00	-30.61	Pk	Horizontal
16200.28	30.99	12.40	43.39	54.00	-10.61	AV	Horizontal
17998.27	28.20	23.10	51.30	74.00	-22.70	Pk	Vertical
17998.16	28.18	23.10	51.28	54.00	-2.72	AV	Vertical
17998.16	28.15	23.10	51.25	74.00	-22.75	Pk	Horizontal
17998.07	28.19	23.10	51.29	54.00	-2.71	AV	Horizontal

Remark:

1. Factor = Antenna Factor + Cable Loss – Pre-amplifier.
2. Scan with 802.11a,802.11n (HT-20) , the worst case is 802.11a.
3. The frequency emission of peak points that did not show above the forms are at least 20dB below the limit, the frequency emission is mainly from the environment noise.



Band IV(5.725-5.850) GHz

Low Channel (802.11/ 5745 MHz)

Frequency	Meter Reading	Factor	Emission Level	Limits	Margin	Detector	Comment
(MHz)	(dBμV)	(dB)	(dBμV/m)	(dBμV/m)	(dB)	Type	
3265.25	45.20	-9.80	35.40	74.00	-38.60	Pk	Vertical
3265.25	45.17	-9.80	35.37	54.00	-18.63	AV	Vertical
3265.22	45.19	-9.80	35.39	74.00	-38.61	Pk	Horizontal
3265.24	45.16	-9.80	35.36	54.00	-18.64	AV	Horizontal
3334.83	42.93	-9.75	33.18	74.00	-40.82	Pk	Vertical
3335.03	42.94	-9.75	33.19	54.00	-20.81	AV	Vertical
3334.83	42.95	-9.75	33.20	74.00	-40.80	Pk	Horizontal
3335.02	42.95	-9.75	33.20	54.00	-20.80	AV	Horizontal
3349.88	42.71	-9.75	32.96	74.00	-41.04	Pk	Vertical
3349.96	42.70	-9.75	32.95	54.00	-21.05	AV	Vertical
3349.88	42.74	-9.75	32.99	74.00	-41.01	Pk	Horizontal
3349.92	42.72	-9.75	32.97	54.00	-21.03	AV	Horizontal
4000.22	40.08	-6.60	33.48	74.00	-40.52	Pk	Vertical
4000.10	40.06	-6.60	33.46	54.00	-20.54	AV	Vertical
4000.19	40.06	-6.60	33.46	74.00	-40.54	Pk	Horizontal
4000.08	40.06	-6.60	33.46	54.00	-20.54	AV	Horizontal
5360.18	38.39	-2.34	36.05	74.00	-37.95	Pk	Vertical
5360.11	38.42	-2.34	36.08	54.00	-17.92	AV	Vertical
5360.18	38.37	-2.34	36.03	74.00	-37.97	Pk	Horizontal
5360.08	38.38	-2.34	36.04	54.00	-17.96	AV	Horizontal
7236.29	37.86	3.40	41.26	74.00	-32.74	Pk	Vertical
7236.35	37.85	3.40	41.25	54.00	-12.75	AV	Vertical
7236.35	37.86	3.40	41.26	74.00	-32.74	Pk	Horizontal
7236.33	37.87	3.40	41.27	54.00	-12.73	AV	Horizontal
8124.39	36.33	4.80	41.13	74.00	-32.87	Pk	Vertical
8124.42	36.29	4.80	41.09	54.00	-12.91	AV	Vertical
8124.42	36.32	4.80	41.12	74.00	-32.88	Pk	Horizontal
8124.41	36.32	4.80	41.12	54.00	-12.88	AV	Horizontal
9105.10	35.15	5.00	40.15	74.00	-33.85	Pk	Vertical
9105.21	35.11	5.00	40.11	54.00	-13.89	AV	Vertical
9105.12	35.11	5.00	40.11	74.00	-33.89	Pk	Horizontal
9105.19	35.13	5.00	40.13	54.00	-13.87	AV	Horizontal
11036.36	34.13	10.20	44.33	74.00	-29.67	Pk	Vertical
11036.52	34.11	10.20	44.31	54.00	-9.69	AV	Vertical



11036.38	34.12	10.20	44.32	74.00	-29.68	Pk	Horizontal
11036.53	34.08	10.20	44.28	54.00	-9.72	AV	Horizontal
11490.37	34.12	10.20	44.32	74.00	-29.68	Pk	Vertical
11490.53	34.09	10.20	44.29	54.00	-9.71	AV	Vertical
11490.39	34.10	10.20	44.30	74.00	-29.70	Pk	Horizontal
11490.57	34.07	10.20	44.27	54.00	-9.73	AV	Horizontal
13299.85	32.95	12.20	45.15	74.00	-28.85	Pk	Vertical
13299.83	32.97	12.20	45.17	54.00	-8.83	AV	Vertical
13299.84	32.97	12.20	45.17	74.00	-28.83	Pk	Horizontal
13299.90	32.94	12.20	45.14	54.00	-8.86	AV	Horizontal
14480.24	31.85	13.40	45.25	74.00	-28.75	Pk	Vertical
14480.36	31.88	13.40	45.28	54.00	-8.72	AV	Vertical
14480.23	31.85	13.40	45.25	74.00	-28.75	Pk	Horizontal
14480.36	31.86	13.40	45.26	54.00	-8.74	AV	Horizontal
16000.23	31.04	12.40	43.44	74.00	-30.56	Pk	Vertical
16000.32	30.99	12.40	43.39	54.00	-10.61	AV	Vertical
16000.21	30.99	12.40	43.39	74.00	-30.61	Pk	Horizontal
16000.31	30.98	12.40	43.38	54.00	-10.62	AV	Horizontal
17235.28	28.18	23.10	51.28	74.00	-22.72	Pk	Vertical
17235.17	28.18	23.10	51.28	54.00	-2.72	AV	Vertical
17235.17	28.15	23.10	51.25	74.00	-22.75	Pk	Horizontal
17235.04	28.18	23.10	51.28	54.00	-2.72	AV	Horizontal
17998.30	28.17	23.10	51.27	74.00	-22.73	Pk	Vertical
17998.19	28.17	23.10	51.27	54.00	-2.73	AV	Vertical
17998.17	28.14	23.10	51.24	74.00	-22.76	Pk	Horizontal
17998.06	28.15	23.10	51.25	54.00	-2.75	AV	Horizontal



Mid Channel (802.11/ 5785 MHz)

Frequency	Meter Reading	Factor	Emission Level	Limits	Margin	Detector	Comment
(MHz)	(dB μ V)	(dB)	(dB μ V/m)	(dB μ V/m)	(dB)	Type	
3265.23	45.18	-9.80	35.38	74.00	-38.62	Pk	Vertical
3265.24	45.17	-9.80	35.37	54.00	-18.63	AV	Vertical
3265.21	45.17	-9.80	35.37	74.00	-38.63	Pk	Horizontal
3265.27	45.17	-9.80	35.37	54.00	-18.63	AV	Horizontal
3334.84	42.90	-9.75	33.15	74.00	-40.85	Pk	Vertical
3335.02	42.92	-9.75	33.17	54.00	-20.83	AV	Vertical
3334.82	42.95	-9.75	33.20	74.00	-40.80	Pk	Horizontal
3335.05	42.96	-9.75	33.21	54.00	-20.79	AV	Horizontal
3349.89	42.72	-9.75	32.97	74.00	-41.03	Pk	Vertical
3349.99	42.72	-9.75	32.97	54.00	-21.03	AV	Vertical
3349.86	42.74	-9.75	32.99	74.00	-41.01	Pk	Horizontal
3349.93	42.72	-9.75	32.97	54.00	-21.03	AV	Horizontal
4000.23	40.04	-6.60	33.44	74.00	-40.56	Pk	Vertical
4000.09	40.07	-6.60	33.47	54.00	-20.53	AV	Vertical
4000.19	40.07	-6.60	33.47	74.00	-40.53	Pk	Horizontal
4000.11	40.06	-6.60	33.46	54.00	-20.54	AV	Horizontal
5360.20	38.39	-2.34	36.05	74.00	-37.95	Pk	Vertical
5360.10	38.43	-2.34	36.09	54.00	-17.91	AV	Vertical
5360.18	38.39	-2.34	36.05	74.00	-37.95	Pk	Horizontal
5360.08	38.37	-2.34	36.03	54.00	-17.97	AV	Horizontal
7236.31	37.84	3.40	41.24	74.00	-32.76	Pk	Vertical
7236.31	37.85	3.40	41.25	54.00	-12.75	AV	Vertical
7236.34	37.86	3.40	41.26	74.00	-32.74	Pk	Horizontal
7236.33	37.88	3.40	41.28	54.00	-12.72	AV	Horizontal
8124.44	36.32	4.80	41.12	74.00	-32.88	Pk	Vertical
8124.43	36.30	4.80	41.10	54.00	-12.90	AV	Vertical
8124.42	36.34	4.80	41.14	74.00	-32.86	Pk	Horizontal
8124.43	36.32	4.80	41.12	54.00	-12.88	AV	Horizontal
9105.09	35.12	5.00	40.12	74.00	-33.88	Pk	Vertical
9105.22	35.13	5.00	40.13	54.00	-13.87	AV	Vertical
9105.12	35.15	5.00	40.15	74.00	-33.85	Pk	Horizontal
9105.22	35.11	5.00	40.11	54.00	-13.89	AV	Horizontal
11036.35	34.12	10.20	44.32	74.00	-29.68	Pk	Vertical
11036.51	34.12	10.20	44.32	54.00	-9.68	AV	Vertical



11036.39	34.12	10.20	44.32	74.00	-29.68	Pk	Horizontal
11036.55	34.08	10.20	44.28	54.00	-9.72	AV	Horizontal
11570.34	34.12	10.20	44.32	74.00	-29.68	Pk	Vertical
11570.52	34.12	10.20	44.32	54.00	-9.68	AV	Vertical
11570.39	34.11	10.20	44.31	74.00	-29.69	Pk	Horizontal
11570.57	34.10	10.20	44.30	54.00	-9.70	AV	Horizontal
13299.85	32.92	12.20	45.12	74.00	-28.88	Pk	Vertical
13299.83	32.95	12.20	45.15	54.00	-8.85	AV	Vertical
13299.86	32.97	12.20	45.17	74.00	-28.83	Pk	Horizontal
13299.88	32.98	12.20	45.18	54.00	-8.82	AV	Horizontal
14480.22	31.85	13.40	45.25	74.00	-28.75	Pk	Vertical
14480.37	31.89	13.40	45.29	54.00	-8.71	AV	Vertical
14480.21	31.87	13.40	45.27	74.00	-28.73	Pk	Horizontal
14480.36	31.91	13.40	45.31	54.00	-8.69	AV	Horizontal
16000.23	31.03	12.40	43.43	74.00	-30.57	Pk	Vertical
16000.32	30.94	12.40	43.34	54.00	-10.66	AV	Vertical
16000.19	30.99	12.40	43.39	74.00	-30.61	Pk	Horizontal
16000.33	30.98	12.40	43.38	54.00	-10.62	AV	Horizontal
17355.27	28.16	23.10	51.26	74.00	-22.74	Pk	Vertical
17355.16	28.17	23.10	51.27	54.00	-2.73	AV	Vertical
17355.15	28.17	23.10	51.27	74.00	-22.73	Pk	Horizontal
17355.07	28.18	23.10	51.28	54.00	-2.72	AV	Horizontal
17998.28	28.20	23.10	51.30	74.00	-22.70	Pk	Vertical
17998.15	28.17	23.10	51.27	54.00	-2.73	AV	Vertical
17998.16	28.16	23.10	51.26	74.00	-22.74	Pk	Horizontal
17998.05	28.19	23.10	51.29	54.00	-2.71	AV	Horizontal



High Channel (802.11/ 5825MHz)

Frequency	Meter Reading	Factor	Emission Level	Limits	Margin	Detector	Comment
(MHz)	(dB μ V)	(dB)	(dB μ V/m)	(dB μ V/m)	(dB)	Type	
3265.22	45.17	-9.80	35.37	74.00	-38.63	Pk	Vertical
3265.20	45.18	-9.80	35.38	54.00	-18.62	AV	Vertical
3265.20	45.18	-9.80	35.38	74.00	-38.62	Pk	Horizontal
3265.24	45.15	-9.80	35.35	54.00	-18.65	AV	Horizontal
3334.85	42.89	-9.75	33.14	74.00	-40.86	Pk	Vertical
3335.00	42.94	-9.75	33.19	54.00	-20.81	AV	Vertical
3334.81	42.94	-9.75	33.19	74.00	-40.81	Pk	Horizontal
3335.03	42.95	-9.75	33.20	54.00	-20.80	AV	Horizontal
3349.89	42.72	-9.75	32.97	74.00	-41.03	Pk	Vertical
3349.97	42.72	-9.75	32.97	54.00	-21.03	AV	Vertical
3349.89	42.71	-9.75	32.96	74.00	-41.04	Pk	Horizontal
3349.92	42.72	-9.75	32.97	54.00	-21.03	AV	Horizontal
4000.21	40.04	-6.60	33.44	74.00	-40.56	Pk	Vertical
4000.07	40.06	-6.60	33.46	54.00	-20.54	AV	Vertical
4000.18	40.05	-6.60	33.45	74.00	-40.55	Pk	Horizontal
4000.07	40.04	-6.60	33.44	54.00	-20.56	AV	Horizontal
5360.20	38.41	-2.34	36.07	74.00	-37.93	Pk	Vertical
5360.12	38.39	-2.34	36.05	54.00	-17.95	AV	Vertical
5360.17	38.40	-2.34	36.06	74.00	-37.94	Pk	Horizontal
5360.08	38.39	-2.34	36.05	54.00	-17.95	AV	Horizontal
7236.31	37.83	3.40	41.23	74.00	-32.77	Pk	Vertical
7236.36	37.83	3.40	41.23	54.00	-12.77	AV	Vertical
7236.34	37.88	3.40	41.28	74.00	-32.72	Pk	Horizontal
7236.36	37.87	3.40	41.27	54.00	-12.73	AV	Horizontal
8124.40	36.35	4.80	41.15	74.00	-32.85	Pk	Vertical
8124.44	36.31	4.80	41.11	54.00	-12.89	AV	Vertical
8124.39	36.31	4.80	41.11	74.00	-32.89	Pk	Horizontal
8124.44	36.33	4.80	41.13	54.00	-12.87	AV	Horizontal
9105.10	35.15	5.00	40.15	74.00	-33.85	Pk	Vertical
9105.25	35.13	5.00	40.13	54.00	-13.87	AV	Vertical
9105.12	35.12	5.00	40.12	74.00	-33.88	Pk	Horizontal
9105.21	35.09	5.00	40.09	54.00	-13.91	AV	Horizontal
11036.33	34.14	10.20	44.34	74.00	-29.66	Pk	Vertical



11036.51	34.10	10.20	44.30	54.00	-9.70	AV	Vertical
11036.36	34.12	10.20	44.32	74.00	-29.68	Pk	Horizontal
11036.57	34.10	10.20	44.30	54.00	-9.70	AV	Horizontal
11650.34	34.14	10.20	44.34	74.00	-29.66	Pk	Vertical
11650.53	34.10	10.20	44.30	54.00	-9.70	AV	Vertical
11650.37	34.12	10.20	44.32	74.00	-29.68	Pk	Horizontal
11650.53	34.09	10.20	44.29	54.00	-9.71	AV	Horizontal
13299.86	32.92	12.20	45.12	74.00	-28.88	Pk	Vertical
13299.84	32.94	12.20	45.14	54.00	-8.86	AV	Vertical
13299.86	32.94	12.20	45.14	74.00	-28.86	Pk	Horizontal
13299.89	32.97	12.20	45.17	54.00	-8.83	AV	Horizontal
14480.21	31.87	13.40	45.27	74.00	-28.73	Pk	Vertical
14480.39	31.90	13.40	45.30	54.00	-8.70	AV	Vertical
14480.20	31.83	13.40	45.23	74.00	-28.77	Pk	Horizontal
14480.38	31.90	13.40	45.30	54.00	-8.70	AV	Horizontal
16000.22	30.99	12.40	43.39	74.00	-30.61	Pk	Vertical
16000.32	30.95	12.40	43.35	54.00	-10.65	AV	Vertical
16000.18	30.99	12.40	43.39	74.00	-30.61	Pk	Horizontal
16000.29	30.98	12.40	43.38	54.00	-10.62	AV	Horizontal
17475.27	28.17	23.10	51.27	74.00	-22.73	Pk	Vertical
17475.18	28.16	23.10	51.26	54.00	-2.74	AV	Vertical
17475.15	28.15	23.10	51.25	74.00	-22.75	Pk	Horizontal
17475.07	28.16	23.10	51.26	54.00	-2.74	AV	Horizontal
17998.27	28.20	23.10	51.30	74.00	-22.70	Pk	Vertical
17998.18	28.15	23.10	51.25	54.00	-2.75	AV	Vertical
17998.16	28.18	23.10	51.28	74.00	-22.72	Pk	Horizontal
17998.06	28.19	23.10	51.29	54.00	-2.71	AV	Horizontal

Remark:

1. Factor = Antenna Factor + Cable Loss – Pre-amplifier.
2. Scan with 802.11a,802.11n (HT-20) , the worst case is 802.11a.
3. The frequency emission of peak points that did not show above the forms are at least 20dB below the limit, the frequency emission is mainly from the environment noise.

**3.2.9 (Band Edge) (worst mode)****Band I(5.15-5.25) GHz**

Frequency (MHz)	Reading (dBuV)	Factor (dB)	Emission Level (dBμV/m)	Limit (dBuV/m)	Margin (dB)	Detect or	Comment
802.11a BW20MHz							
5150	42.00	10.25	52.25	74	-21.75	PK	Vertical
5150	31.91	10.25	42.16	54	-11.84	AV	Vertical
5150	42.35	10.25	52.60	74	-21.40	PK	Horizontal
5150	31.87	10.25	42.12	54	-11.88	AV	Horizontal
5350	42.38	12.45	54.83	74	-19.17	PK	Vertical
5350	32.07	12.45	44.52	54	-9.48	AV	Vertical
5350	42.10	12.45	54.55	74	-19.45	PK	Horizontal
5350	32.14	12.45	44.59	54	-9.41	AV	Horizontal
802.11n BW20MHz							
5150	42.34	10.25	52.59	74	-21.41	PK	Vertical
5150	32.31	10.25	42.56	54	-11.44	AV	Vertical
5150	42.15	10.25	52.40	74	-21.60	PK	Horizontal
5150	32.10	10.25	42.35	54	-11.65	AV	Horizontal
5350	42.11	12.45	54.56	74	-19.44	PK	Vertical
5350	31.92	12.45	44.37	54	-9.63	AV	Vertical
5350	42.22	12.45	54.67	74	-19.33	PK	Horizontal
5350	32.02	12.45	44.47	54	-9.53	AV	Horizontal

**Band IV(5.725-5.85 GHz)**

Frequency (MHz)	Reading (dBuV)	Factor (dB)	Emission Level (dB μ V/m)	Limit (dBuV/m)	Margin (dB)	Detector	Comment
802.11a BW20MHz							
5725	42.00	10.65	52.65	74	-21.35	PK	Vertical
5725	31.90	10.65	42.55	54	-11.45	AV	Vertical
5725	42.10	10.65	52.75	74	-21.25	PK	Horizontal
5725	32.14	10.65	42.79	54	-11.21	AV	Horizontal
5850	42.20	12.98	55.18	74	-18.82	PK	Vertical
5850	32.16	12.98	45.14	54	-8.86	AV	Vertical
5850	42.05	12.98	55.03	74	-18.97	PK	Horizontal
5850	31.91	12.98	44.89	54	-9.11	AV	Horizontal
802.11n BW20MHz							
5725	41.94	10.65	52.59	74	-21.41	PK	Vertical
5725	32.31	10.65	42.96	54	-11.04	AV	Vertical
5725	42.17	10.65	52.82	74	-21.18	PK	Horizontal
5725	32.22	10.65	42.87	54	-11.13	AV	Horizontal
5850	42.28	12.98	55.26	74	-18.74	PK	Vertical
5850	31.87	12.98	44.85	54	-9.15	AV	Vertical
5850	42.06	12.98	55.04	74	-18.96	PK	Horizontal
5850	32.07	12.98	45.05	54	-8.95	AV	Horizontal

4. CONDUCTED SPURIOUS EMISSIONS

4.1 APPLIED PROCEDURES / LIMIT

Undesirable emission limits. Except as shown in paragraph (b)(7) of this section, the maximum emissions outside of the frequency bands of operation shall be attenuated in accordance with the following limits:

(1) For transmitters operating in the 5.15-5.25 GHz band: All emissions outside of the 5.15-5.35 GHz band shall not exceed an e.i.r.p. of -27 dBm/MHz.

(2) For transmitters operating in the 5.725-5.85 GHz band: All emissions within the frequency range from the band edge to 10 MHz above or below the band edge shall not exceed an e.i.r.p. of -17 dBm/MHz; for frequencies 10 MHz or greater above or below the band edge, emissions shall not exceed an e.i.r.p. of -27 dBm/MHz.

4.1.1 TEST PROCEDURE

Spectrum Parameter	Setting
Detector	Peak
Start/Stop Frequency	30 MHz to 10th carrier harmonic
RB / VB (emission in restricted band)	1000 KHz/3000 KHz
Trace-Mode:	Max hold

For Band edge

Spectrum Parameter	Setting
Detector	Peak
Start/Stop Frequency	Lower Band Edge: 5700 to 5725 MHz Upper Band Edge: 5850 to 5870 MHz
RB / VB (emission in restricted band)	1000 KHz/3000 KHz
Trace-Mode:	Max hold

4.1.2 DEVIATION FROM STANDARD

No deviation.

4.1.3 TEST SETUP

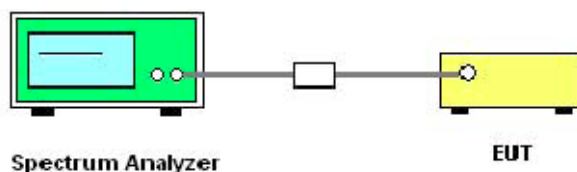

The EUT which is powered by the Battery, is coupled to the Spectrum Analyzer; the RF load attached to the EUT antenna terminal is 50Ohm; the path loss as the factor is calibrated to correct the reading.

Make the measurement with the spectrum analyzer's resolution bandwidth (RBW) = 1000 kHz. In order to make an accurate measurement, set the span greater than RBW.

4.1.4 EUT OPERATION CONDITIONS

The EUT tested system was configured as the statements of 2.3 Unless otherwise a special operating condition is specified in the follows during the testing.



4.1.5 TEST RESULTS

Not: Above 26.5GHz amplitude of spurious emissions which are attenuated by more than 10dB below the permissible value has.

Band I (5.15-5.25GHz)

TX Spurious Emissions /802.11a Mode CH 36 (30M-1G)

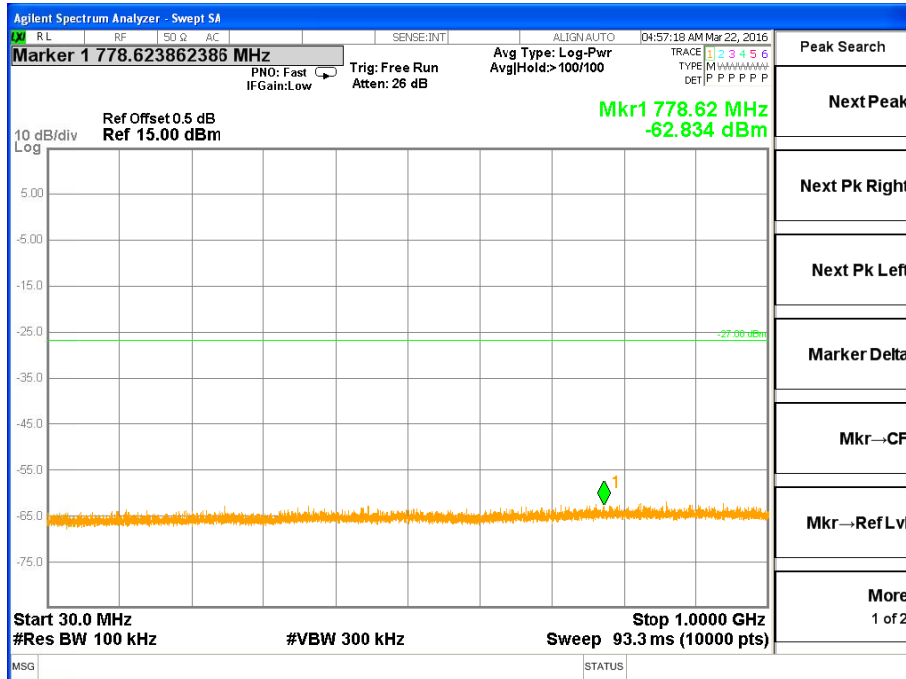

TX Spurious Emissions /802.11a Mode CH 36 (1G-26.5G)

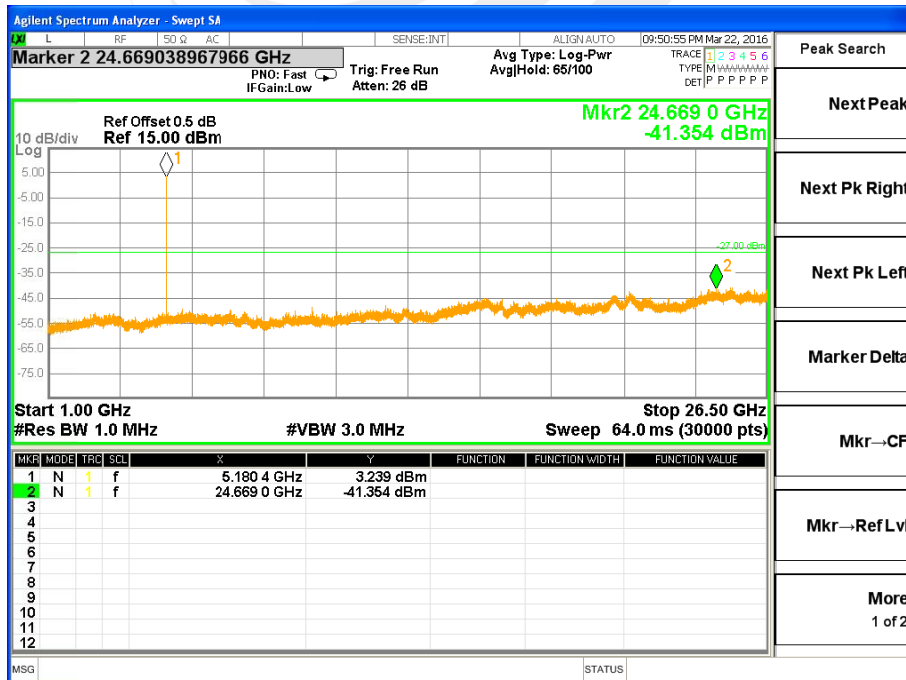



TX Spurious Emissions /802.11a Mode CH 40(30M-1G)

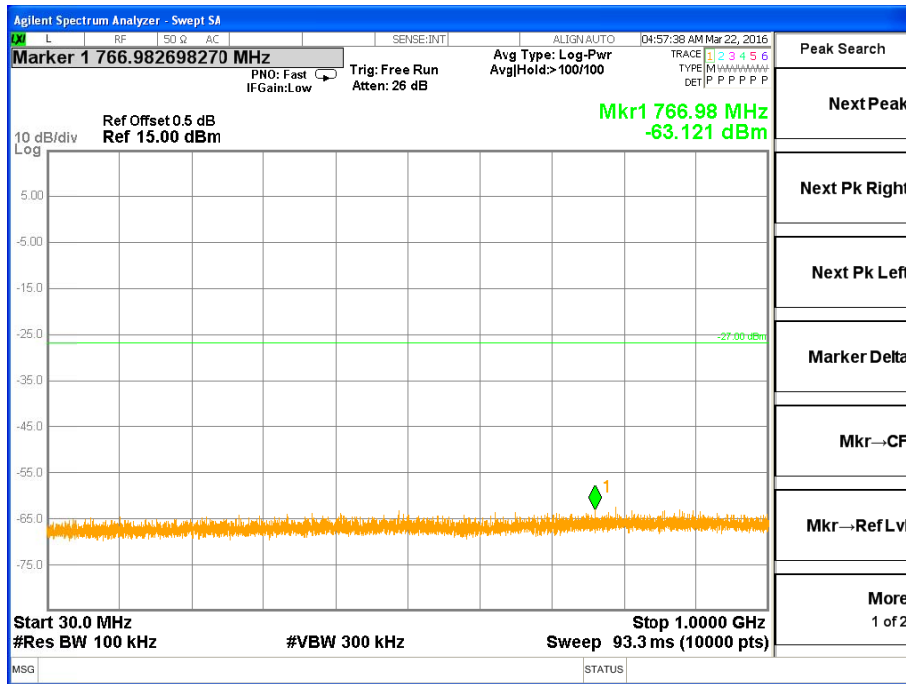

TX Spurious Emissions /802.11a Mode CH 40(1G-26.5G)

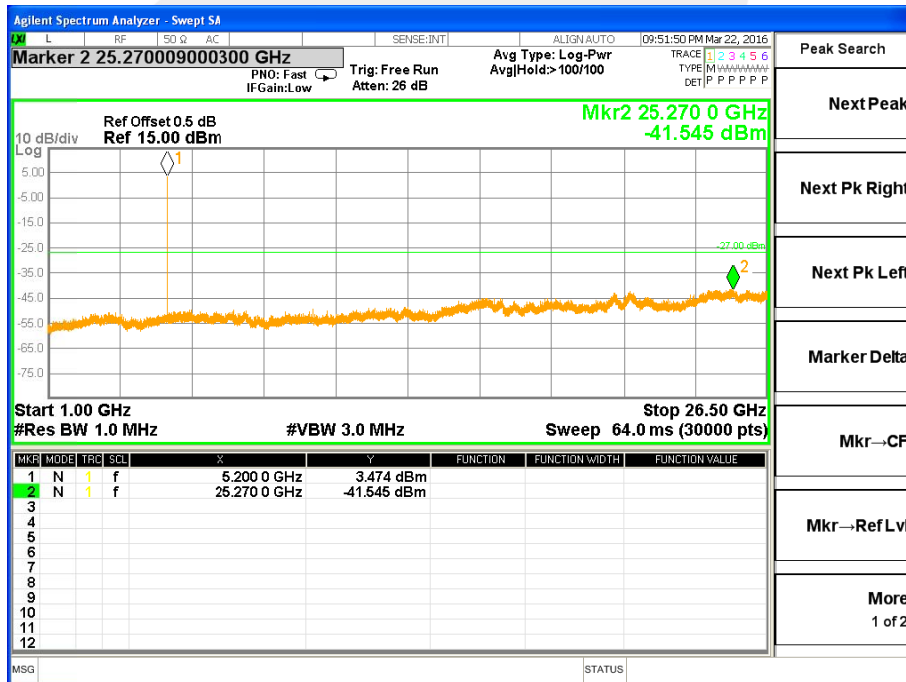



TX Spurious Emissions /802.11a Mode CH 48(30M-1G)

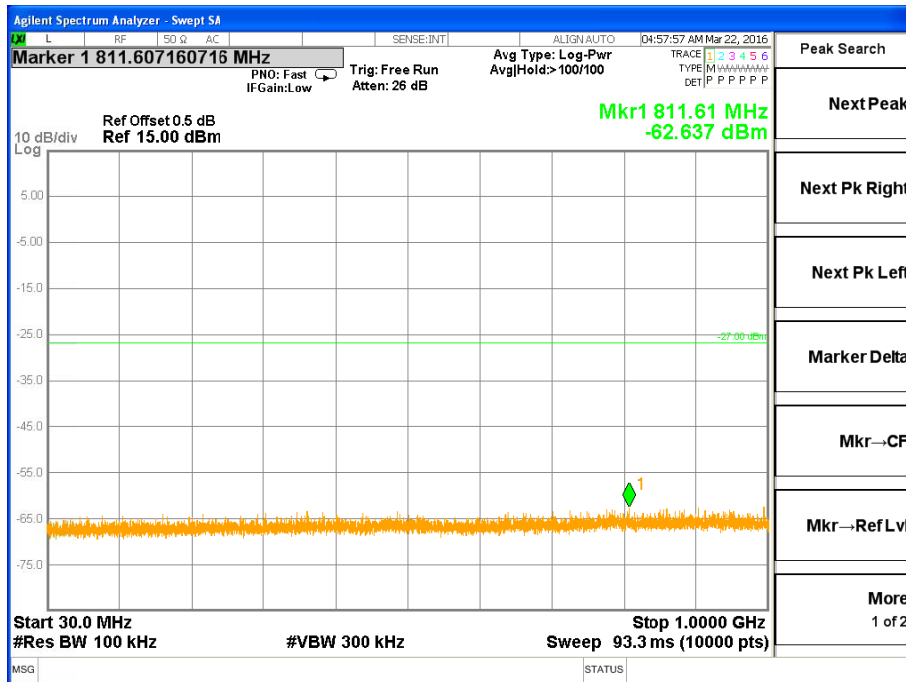

TX Spurious Emissions /802.11a Mode CH 48(1G-26.5G)

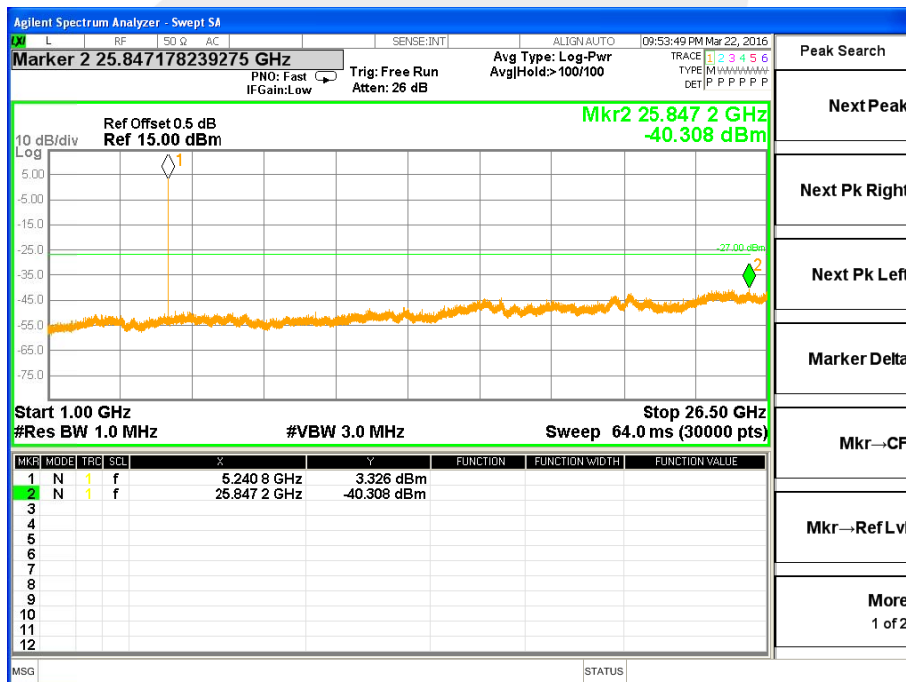



Band edge

TX Band edge /802.11a Mode CH 36

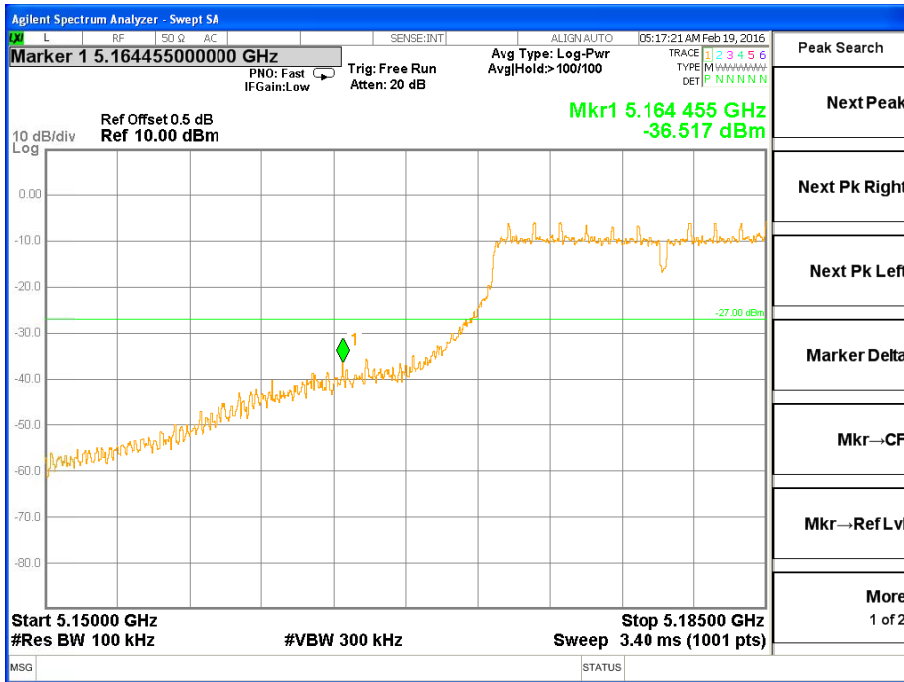

TX Band edge /802.11a Mode CH 48

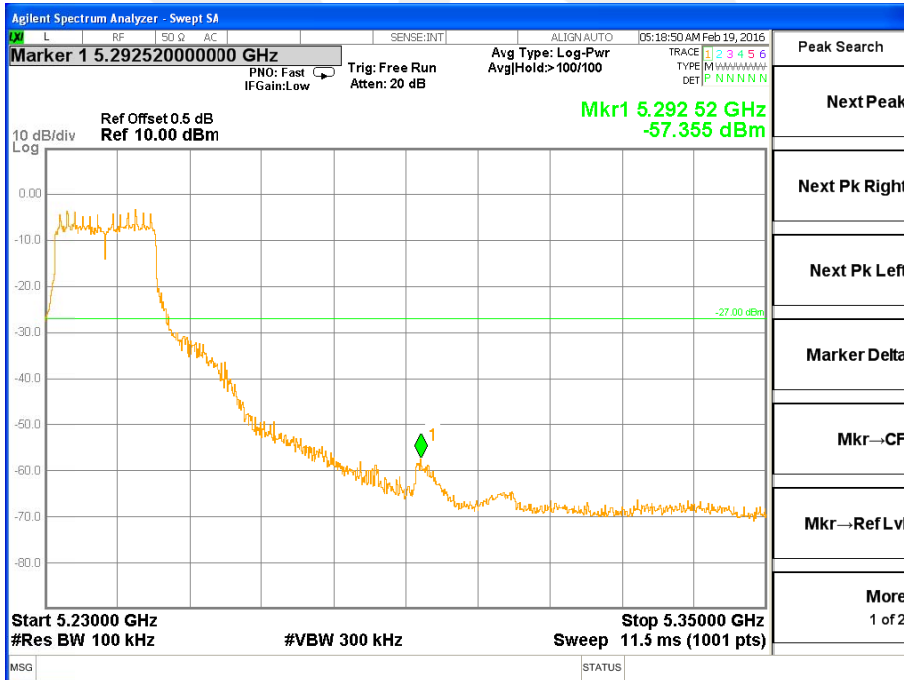



Band I (5.15-5.25GHz)

TX Spurious Emissions /802.11n(HT20) Mode CH 36 (30M-1G)

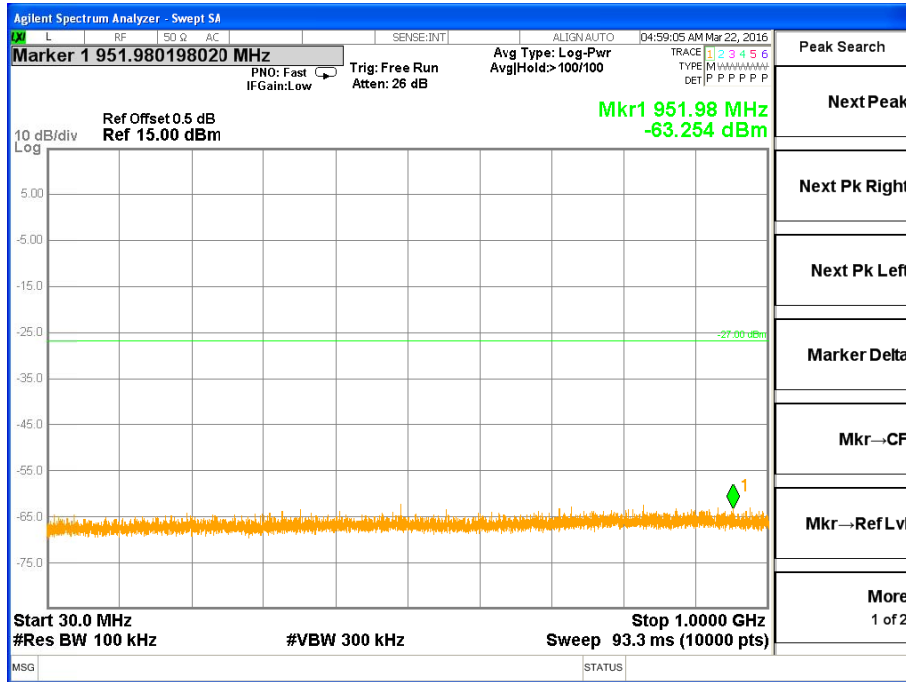

TX Spurious Emissions /802.11n(HT20) Mode CH 36 (1G-26.5G)

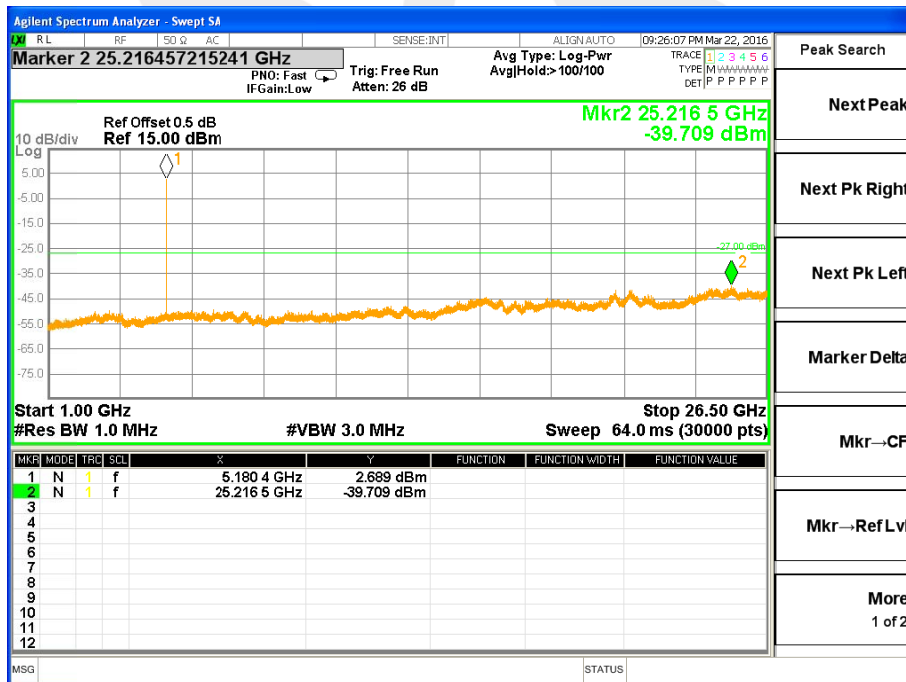



TX Spurious Emissions /802.11n(HT20) Mode CH 40 (30M-1G)

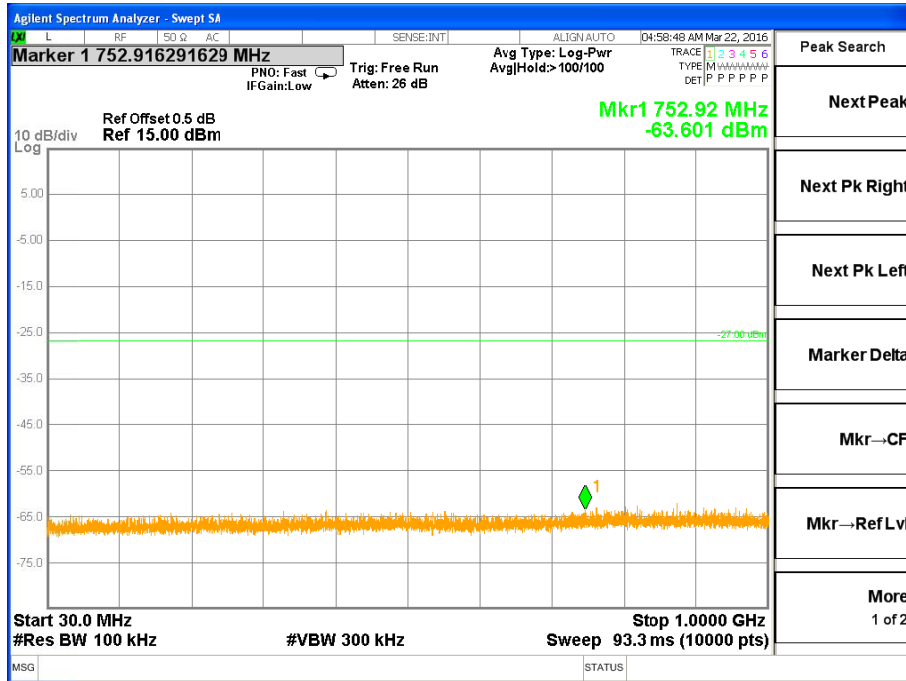

TX Spurious Emissions /802.11n(HT20) Mode CH 40 (1G-26.5G)

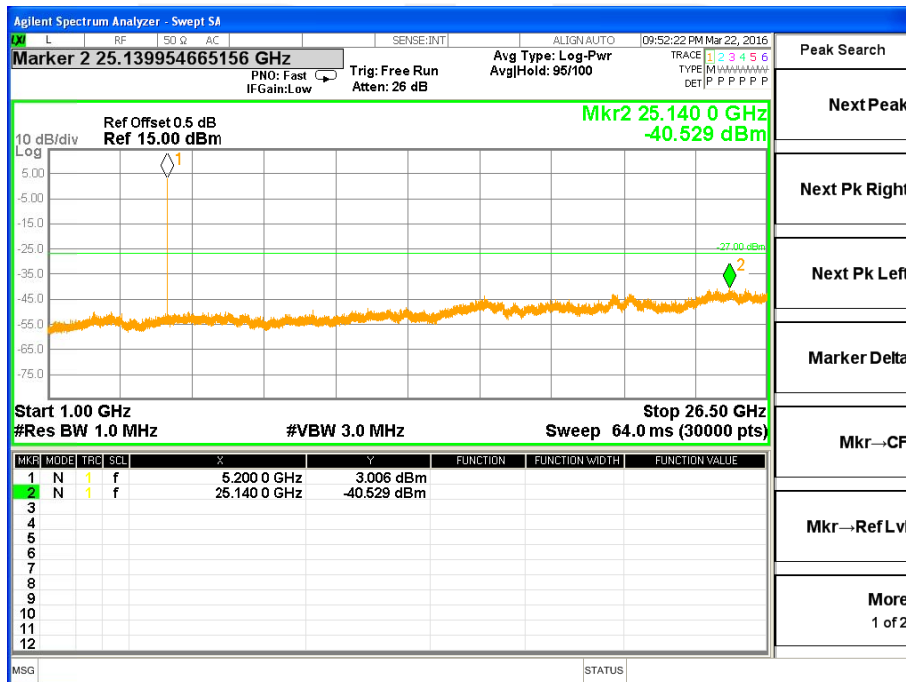



TX Spurious Emissions /802.11n(HT20) Mode CH 48(30M-1G)

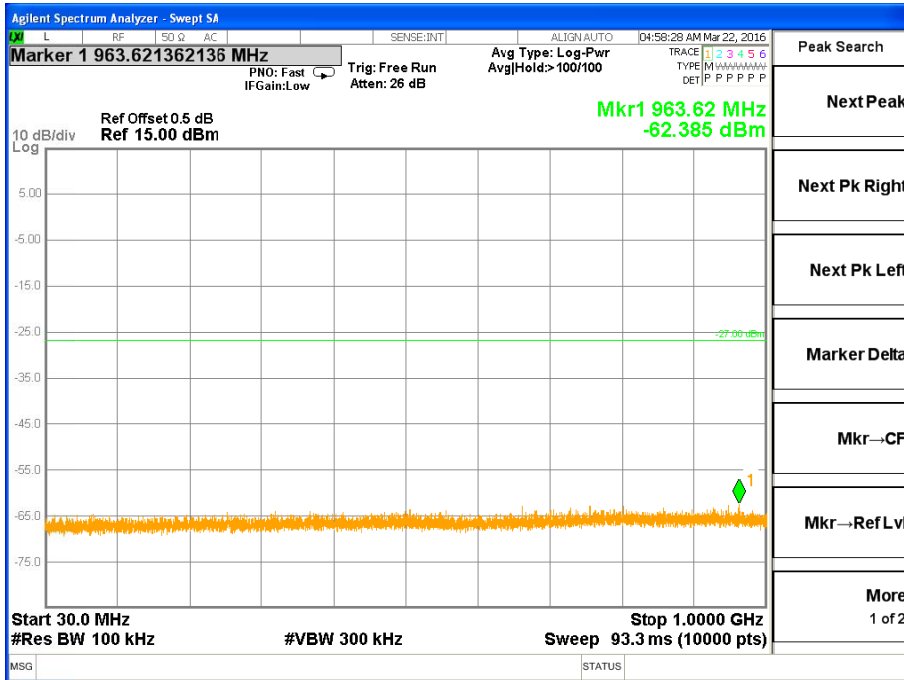

TX Spurious Emissions /802.11n(HT20) Mode CH 48(1G-26.5G)

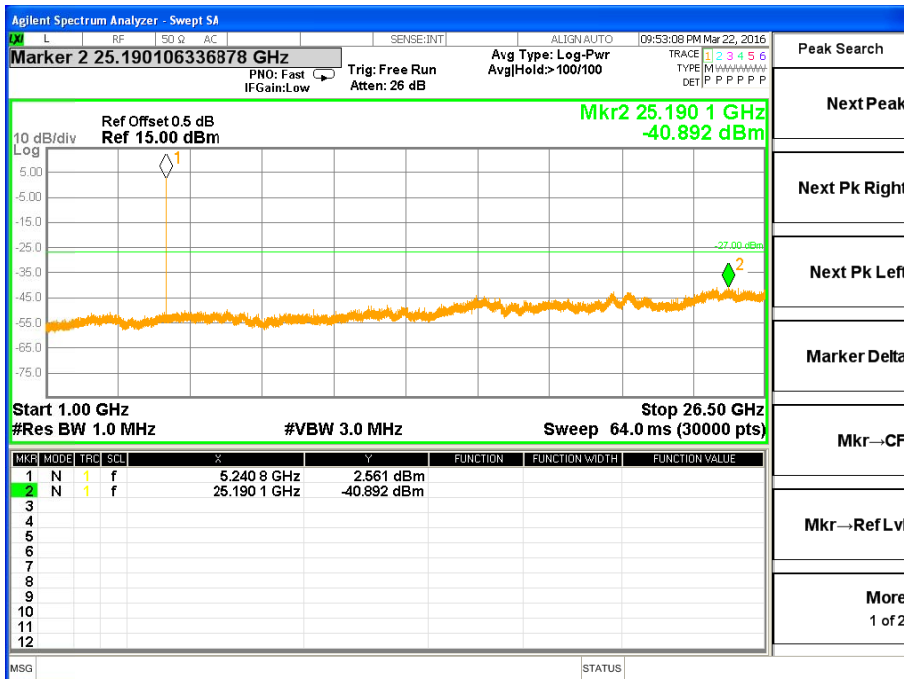



Band edge

TX Band edge /802.11n(HT20) Mode CH 36

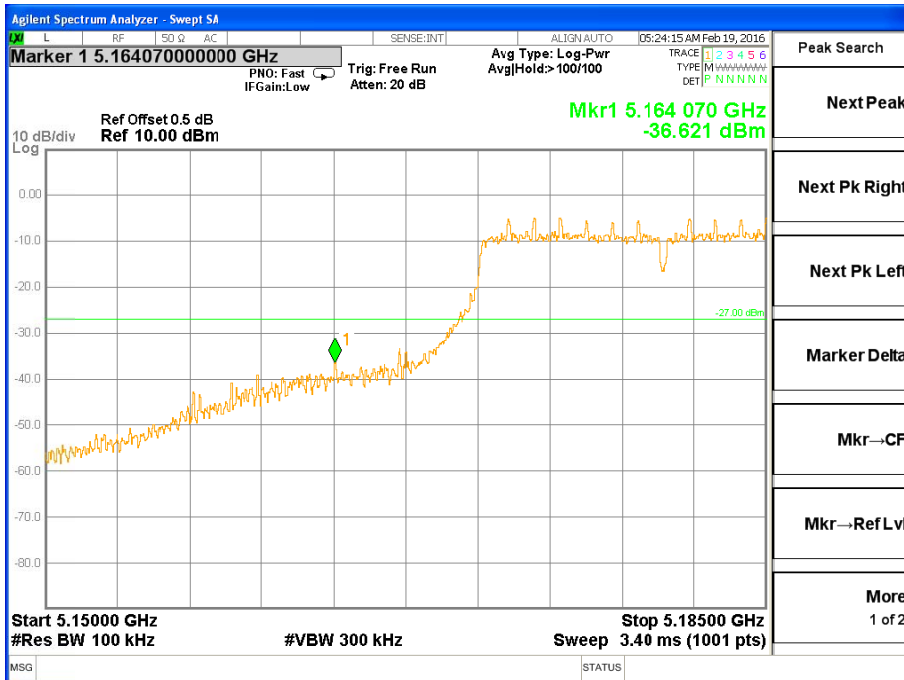

TX Band edge /802.11n(HT20) Mode CH 48

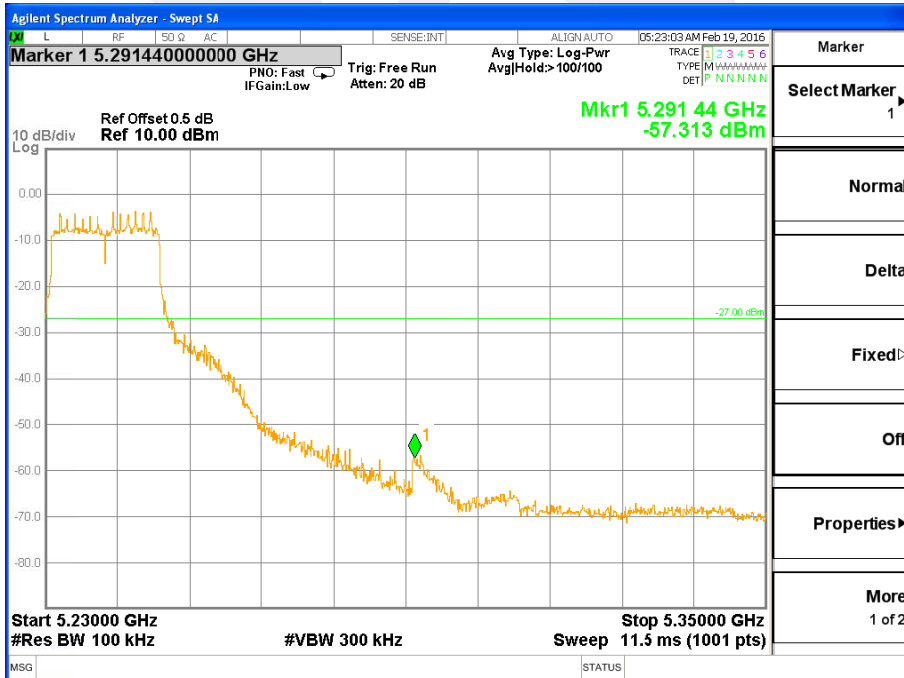



Band IV (5.725-5.85GHz)

TX Spurious Emissions /802.11a Mode CH 149 (30M-1G)

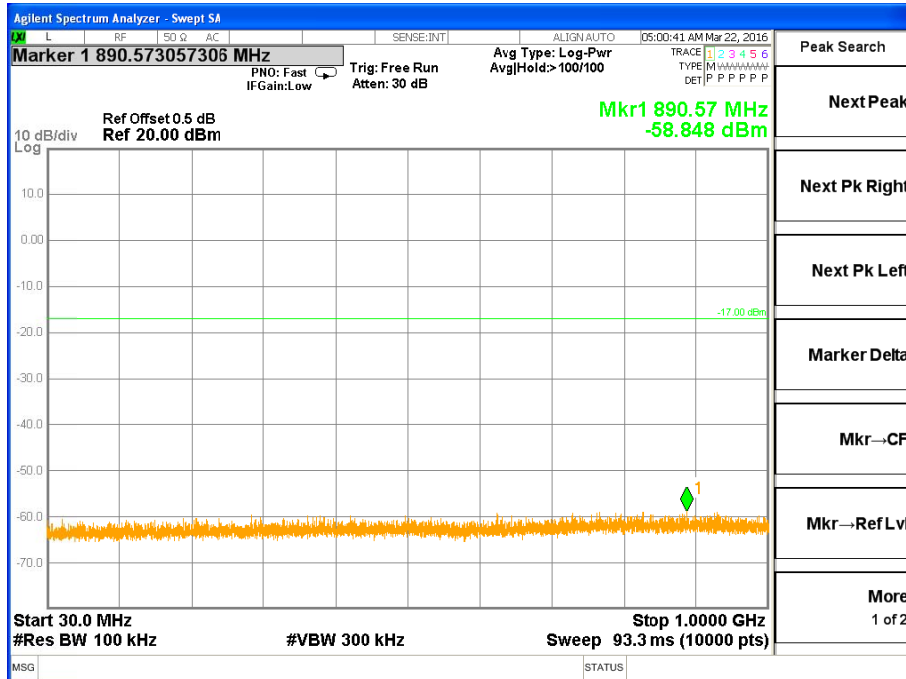

TX Spurious Emissions /802.11a Mode CH 3149 (1G-26.5G)

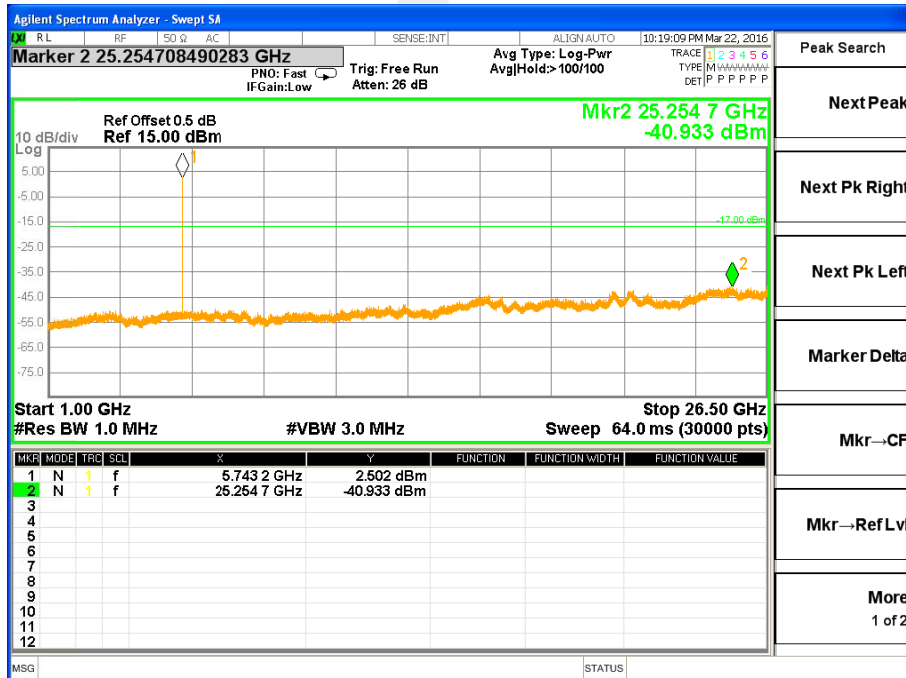



TX Spurious Emissions /802.11a Mode CH 157(30M-1G)

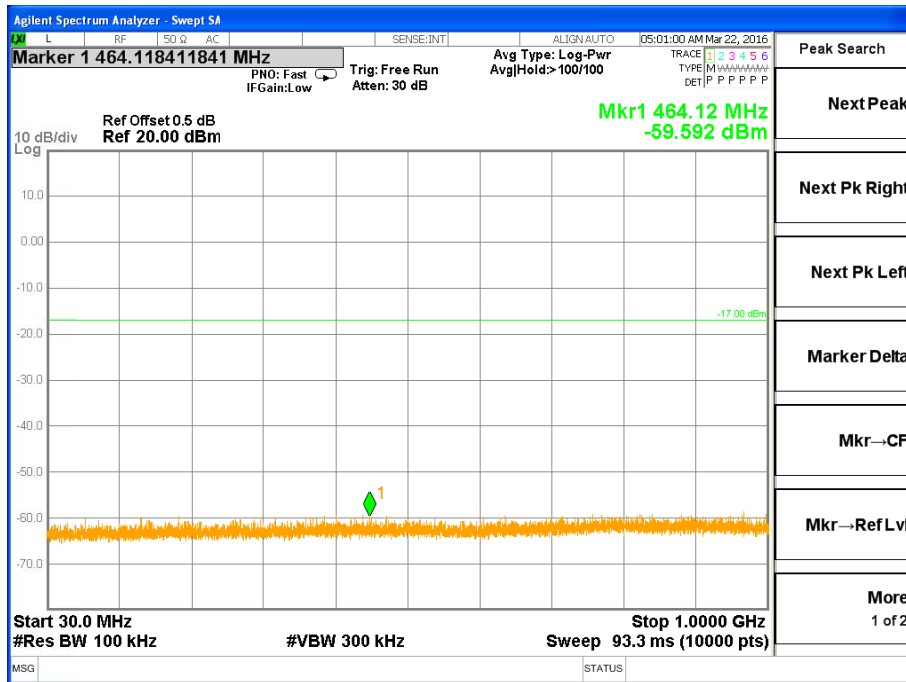

TX Spurious Emissions /802.11a Mode CH 157(1G-26.5G)

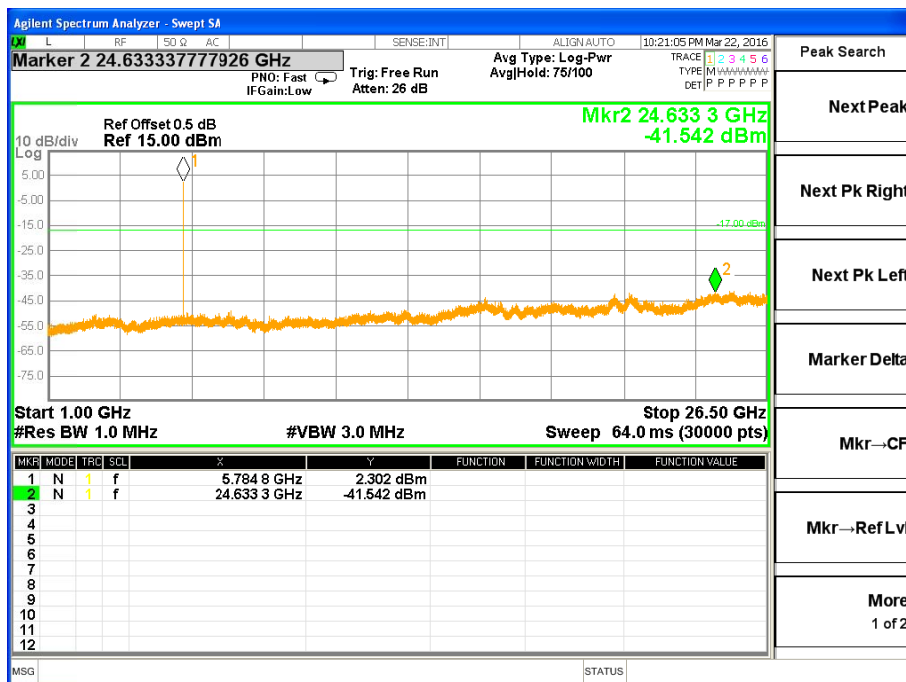



TX Spurious Emissions /802.11a Mode CH 161 (30M-1G)

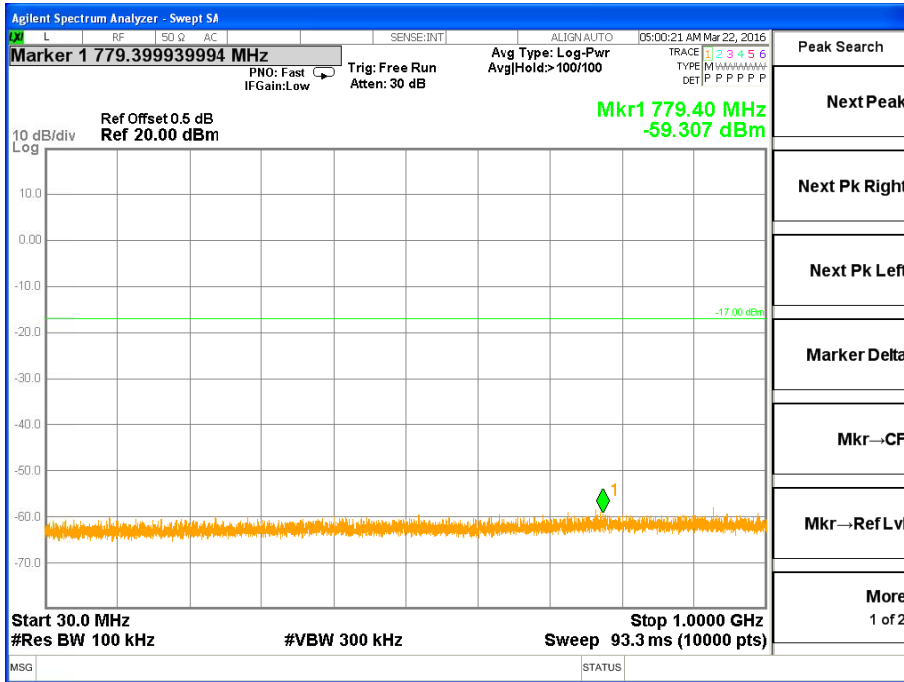

TX Spurious Emissions /802.11a Mode CH 161(1G-26.5G)

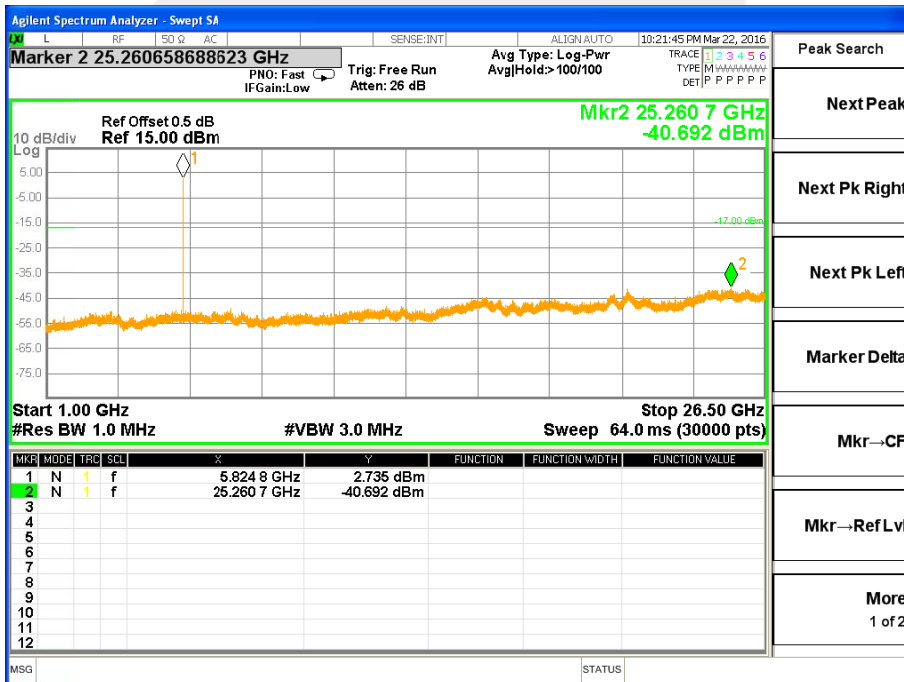



Band edge

TX Band edge /802.11a Mode CH 149

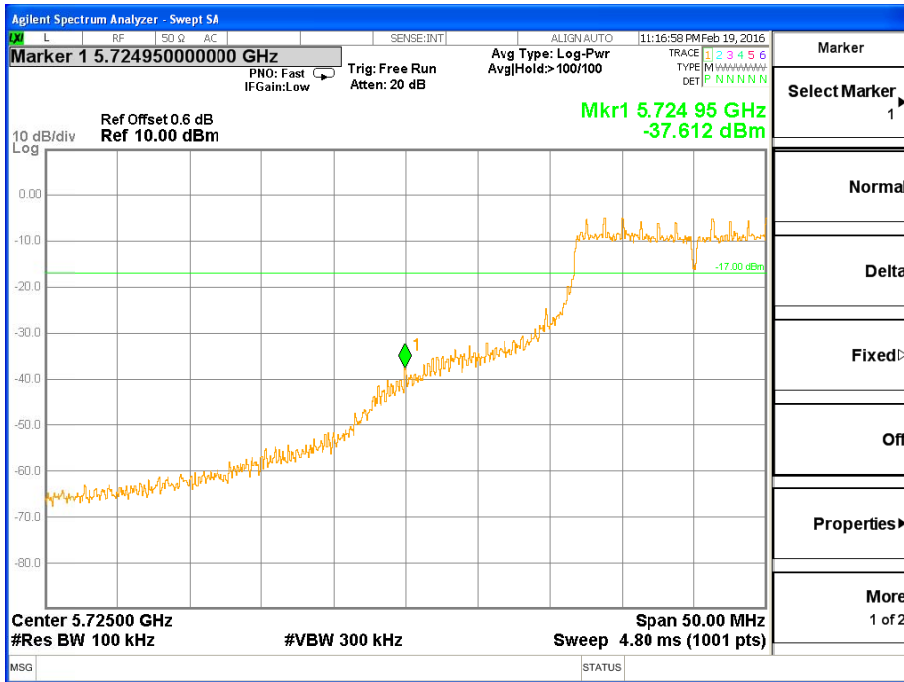

TX Band edge /802.11a Mode CH 161

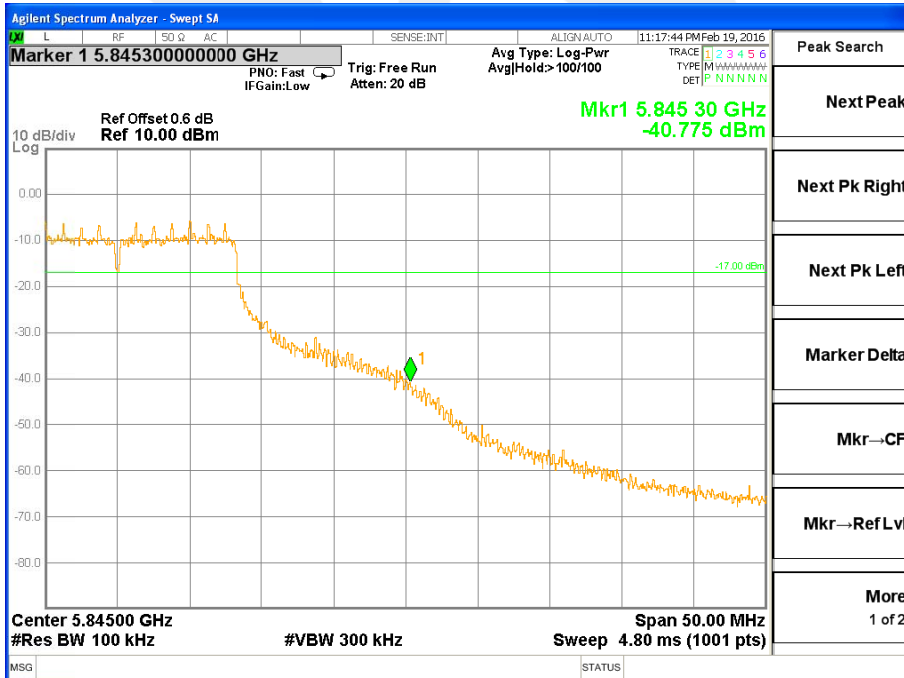



Band IV (5.725-5.85GHz)

TX Spurious Emissions /802.11n(HT20) Mode CH 149 (30M-1G)

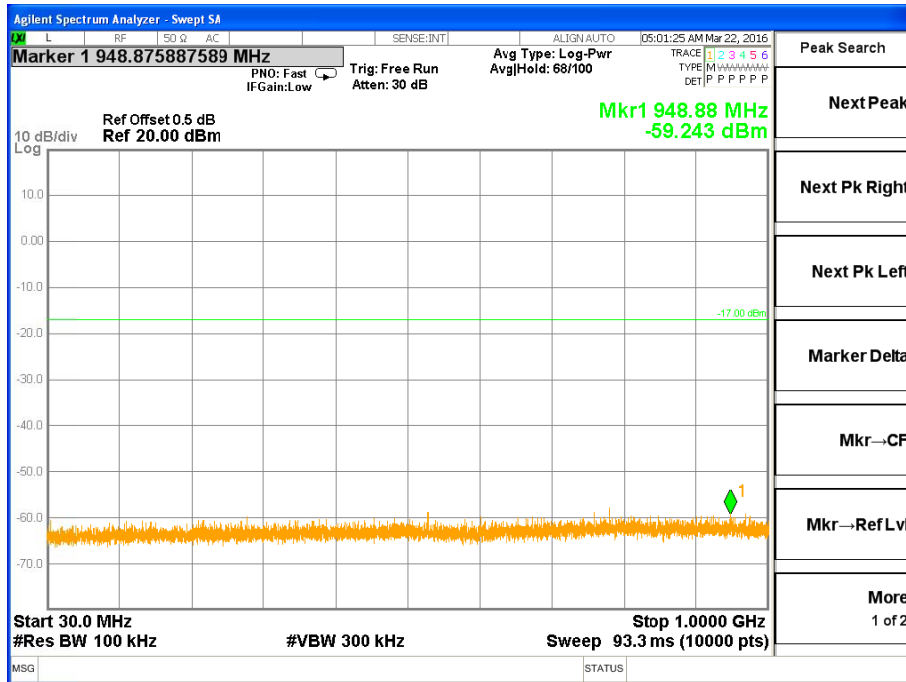

TX Spurious Emissions /802.11n(HT20) Mode CH 149 (1G-26.5G)

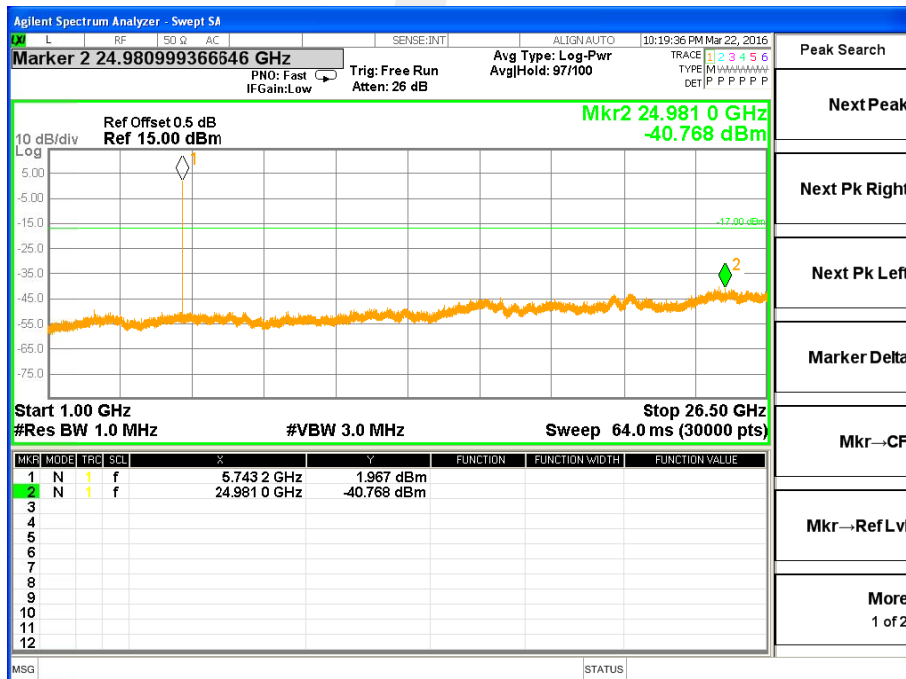



TX Spurious Emissions /802.11n(HT20) Mode CH 157 (30M-1G)

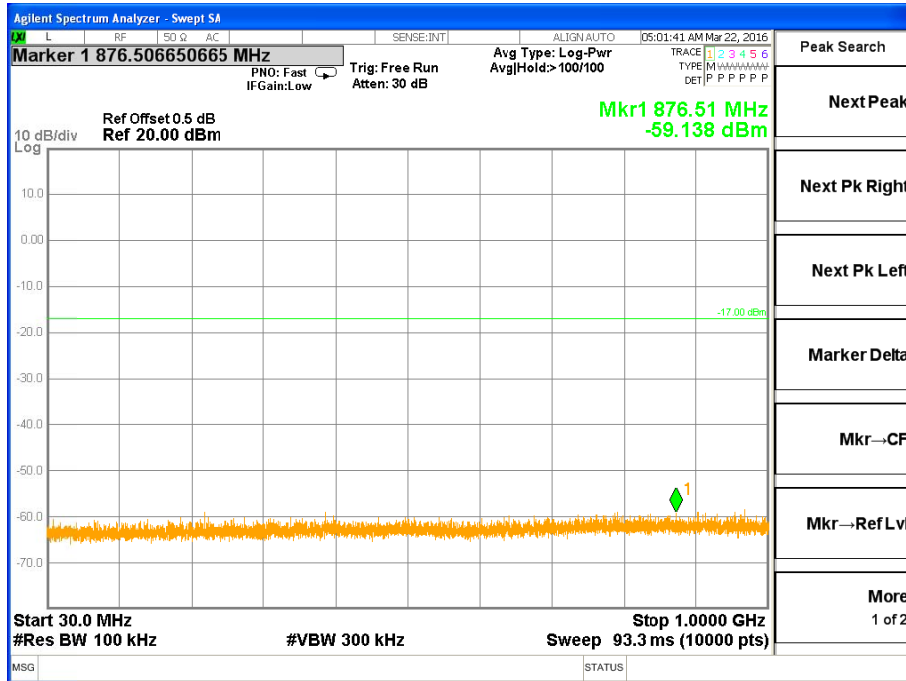

TX Spurious Emissions /802.11n(HT20) Mode CH 157 (1G-26.5G)

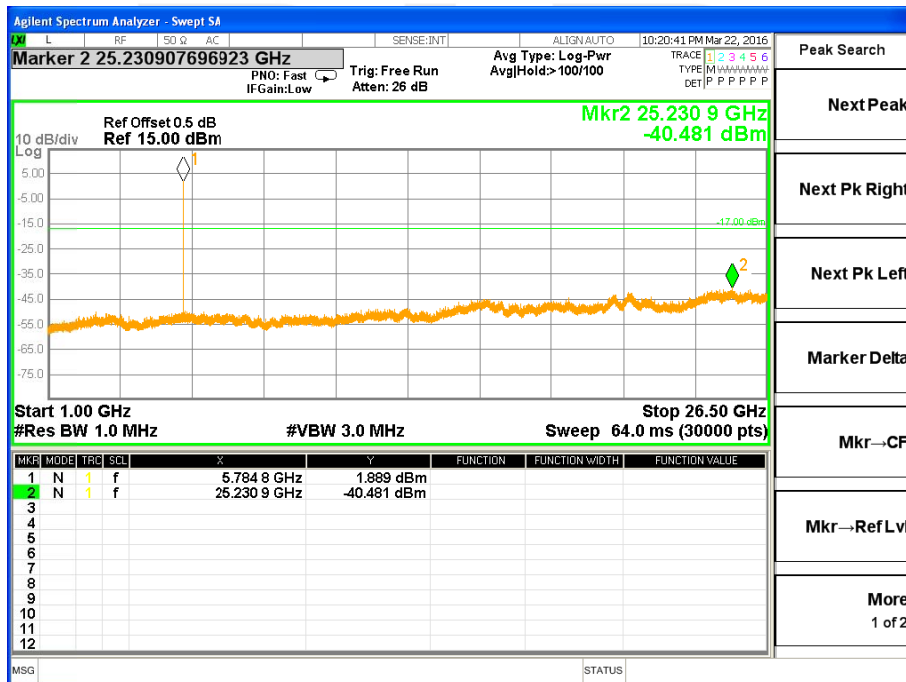



TX Spurious Emissions /802.11n(HT20) Mode CH 161(30M-1G)

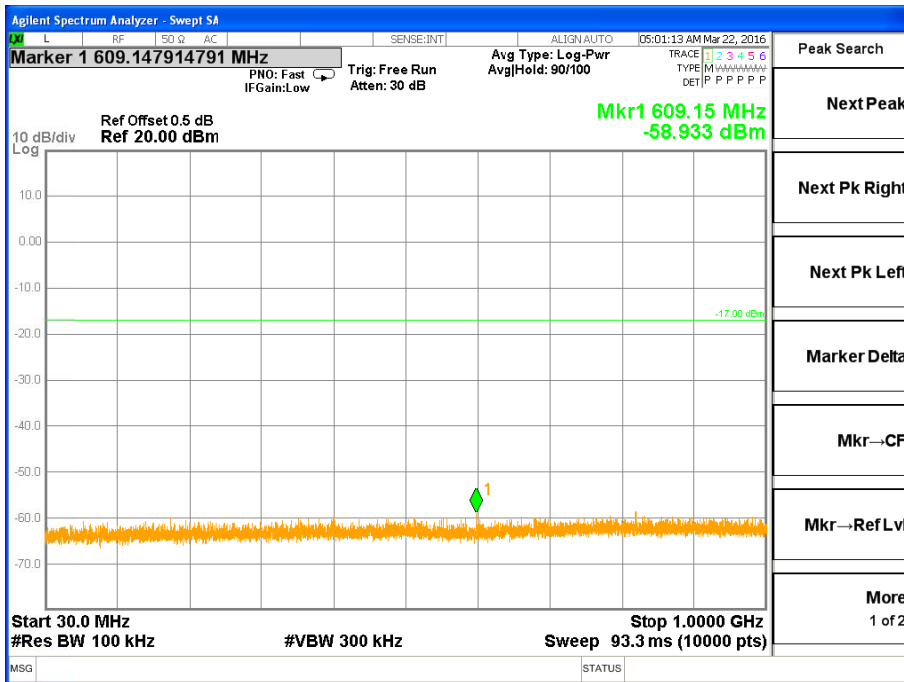

TX Spurious Emissions /802.11n(HT20) Mode CH 161(1G-26.5G)

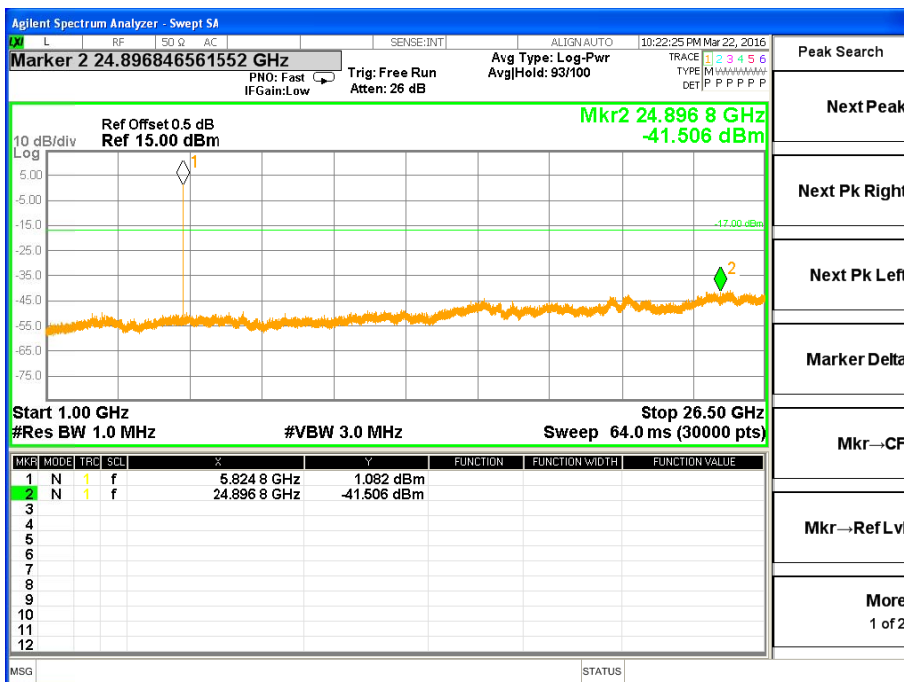



Band edge

TX Band edge /802.11n(HT20) Mode CH 149

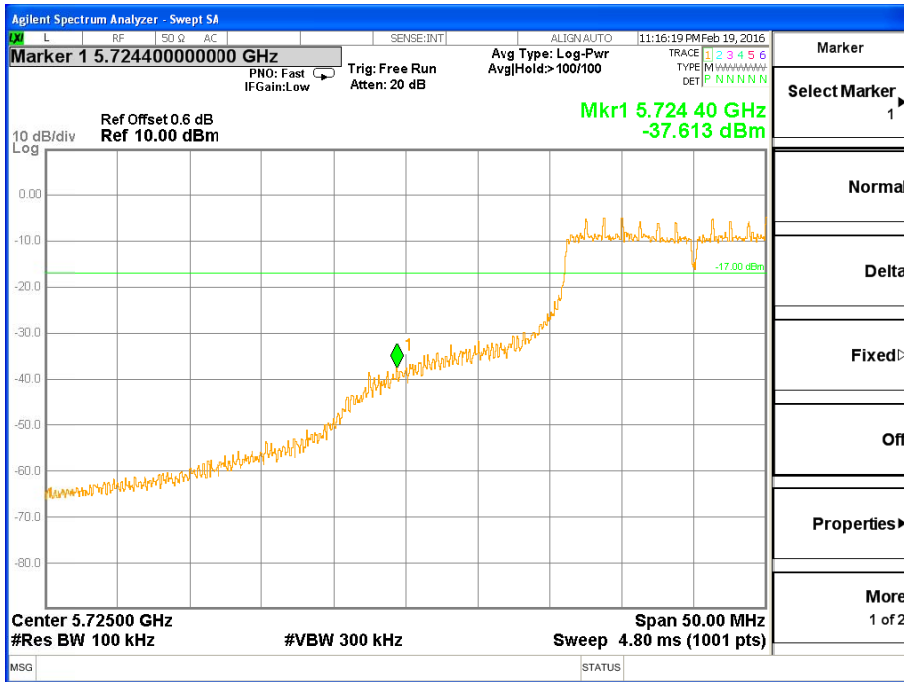

TX Band edge /802.11n(HT20) Mode CH 161

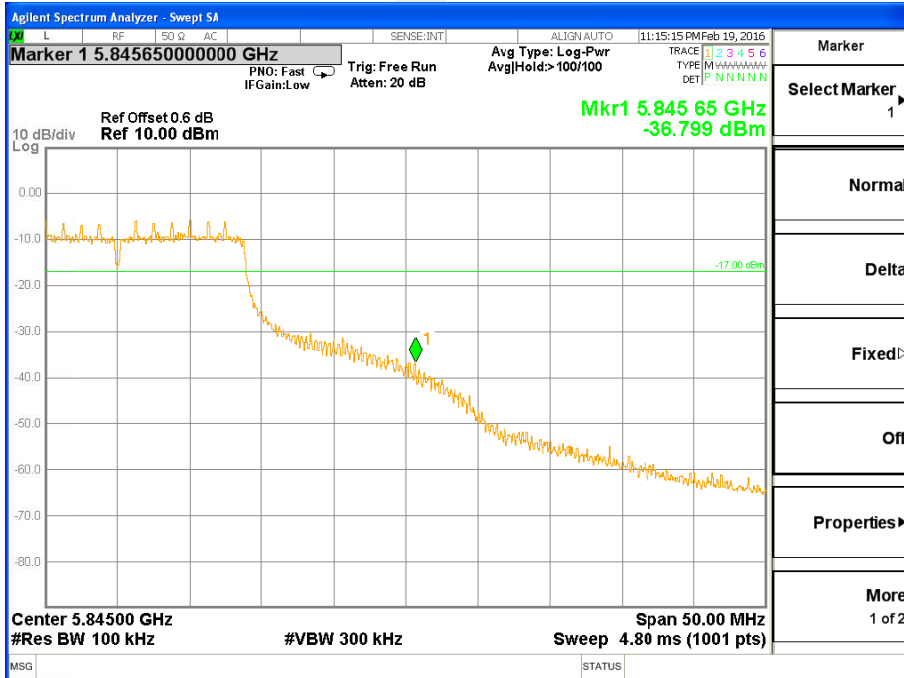



5. POWER SPECTRAL DENSITY TEST

5.1 APPLIED PROCEDURES / LIMIT

1. For mobile and portable client devices in the 5.15-5.25 GHz band, the peak power spectral density shall not exceed 11 dBm in any 1MHz band.
2. For the band 5.725-5.850 GHz, the peak power spectral density shall not exceed 30 dBm in any 500KHz band. If transmitting antenna directional gain is greater than 6 dBi, both the maximum conducted output power and the peak power spectral density shall be reduced by the amount in dB that the directional gain of the antenna exceeds 6 dBi.

5.1.1 TEST PROCEDURE

1. The setting follows Method SA-1 of FCC KDB 789033 D02 General UNII Test Procedures New Rules v01r01.

For devices operating in the band, the rules specify a measurement bandwidth of 500 kHz. Many spectrum analyzers do not have 500 kHz RBW, thus a narrower RBW may need to be used. The rules permit the use of a RBWs less than 1 MHz, or 500 kHz, "provided that the measured power is integrated over the full reference bandwidth" to show the total power over the specified measurement bandwidth (*i.e.*, 1 MHz, or 500 kHz). If measurements are performed using a reduced resolution bandwidth (< 1 MHz, or < 500 kHz) and integrated over 1 MHz, or 500 KHz bandwidth, the following adjustments to the procedures apply:

- a) Set $RBW \geq 1/T$, where T is defined in section II.B.I.a).
- b) Set $VBW \geq 3 RBW$.
- c) If measurement bandwidth of Maximum PSD is specified in 500 kHz, add $10 \log (500\text{kHz}/RBW)$ to the measured result, whereas $RBW (< 500 \text{ kHz})$ is the reduced resolution bandwidth of the spectrum analyzer set during measurement.
- d) If measurement bandwidth of Maximum PSD is specified in 1 MHz, add $10 \log (1\text{MHz}/RBW)$ to the measured result, whereas $RBW (< 1 \text{ MHz})$ is the reduced resolution bandwidth of spectrum analyzer set during measurement.
- e) Care must be taken to ensure that the measurements are performed during a period of continuous transmission or are corrected upward for duty cycle.

Note: As a practical matter, it is recommended to use reduced RBW of 100 kHz for the sections 5.c) and 5.d) above, since $RBW=100 \text{ KHZ}$ is available on nearly all spectrum analyzers.

5.1.2 DEVIATION FROM STANDARD

No deviation.

5.1.3 TEST SETUP



5.1.4 EUT OPERATION CONDITIONS

The EUT tested system was configured as the statements of 2.1 Unless otherwise a special operating condition is specified in the follows during the testing.





5.1.5 TEST RESULTS

Band I (5.15-5.25GHz)802.11a

Frequency	Power Density (dBm)	Limit (dBm)	Result
5180	-12.55	11	PASS
5200	-11.87	11	PASS
5240	-10.88	11	PASS

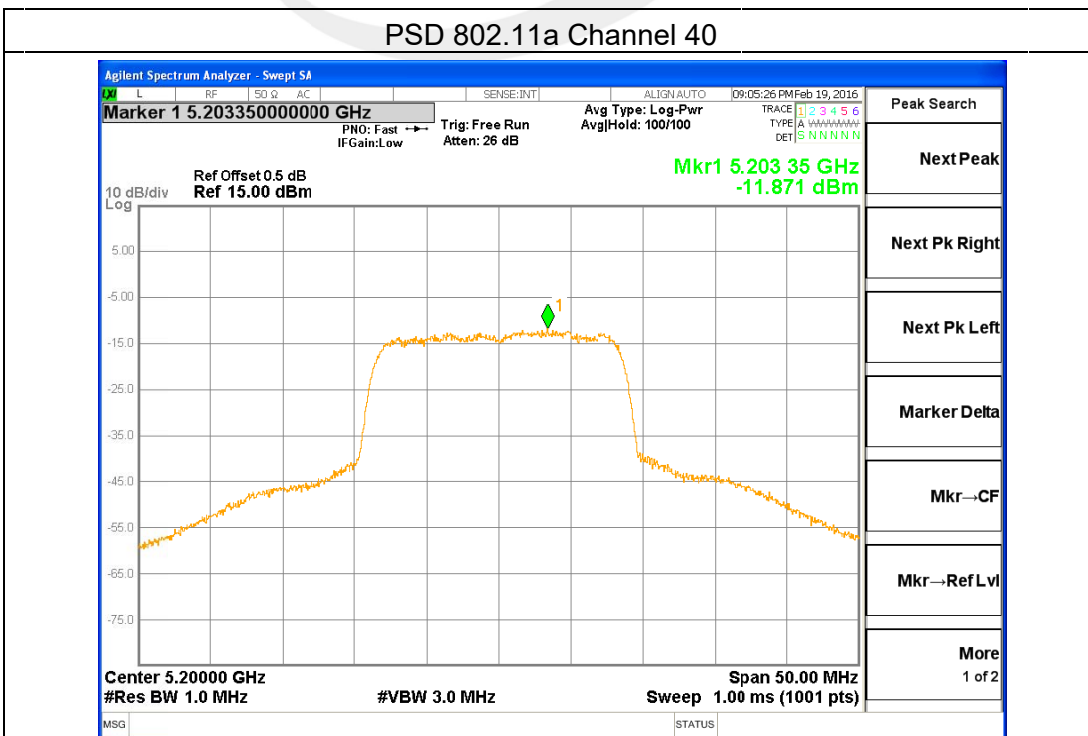
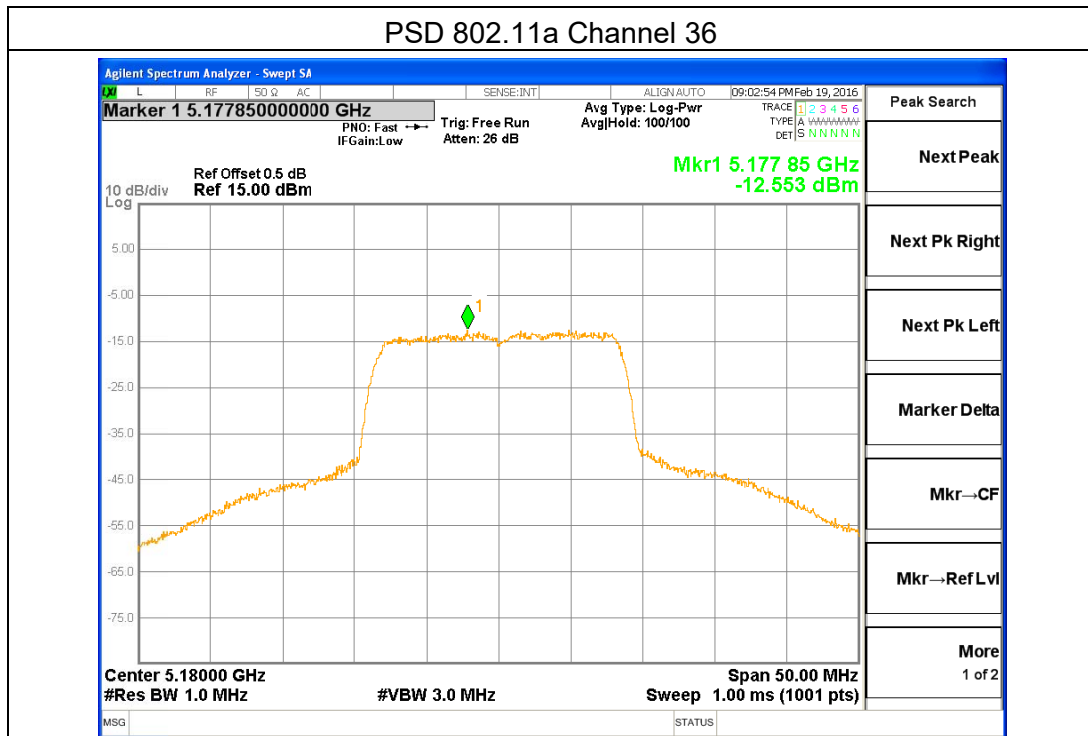

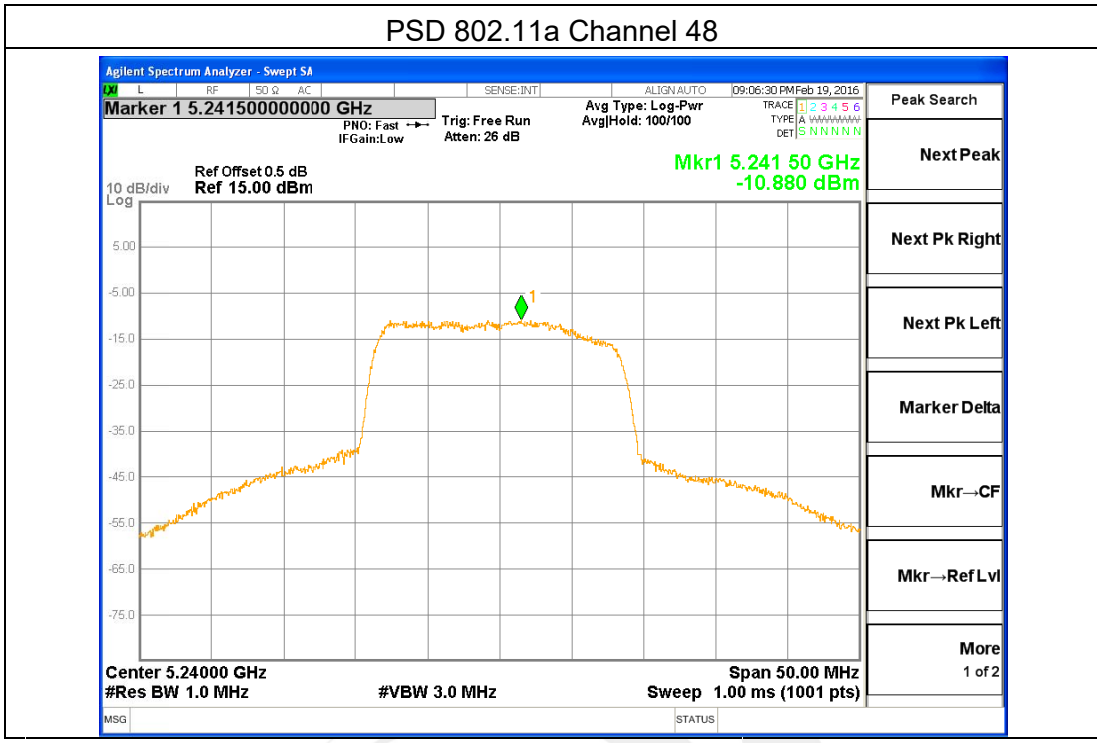



Band I (5.15-5.25GHz) 802.11n(HT20)

Frequency	Power Density (dBm)	Limit (dBm)	Result
5180	-14.76	11	PASS
5200	-12.90	11	PASS
5240	-13.37	11	PASS

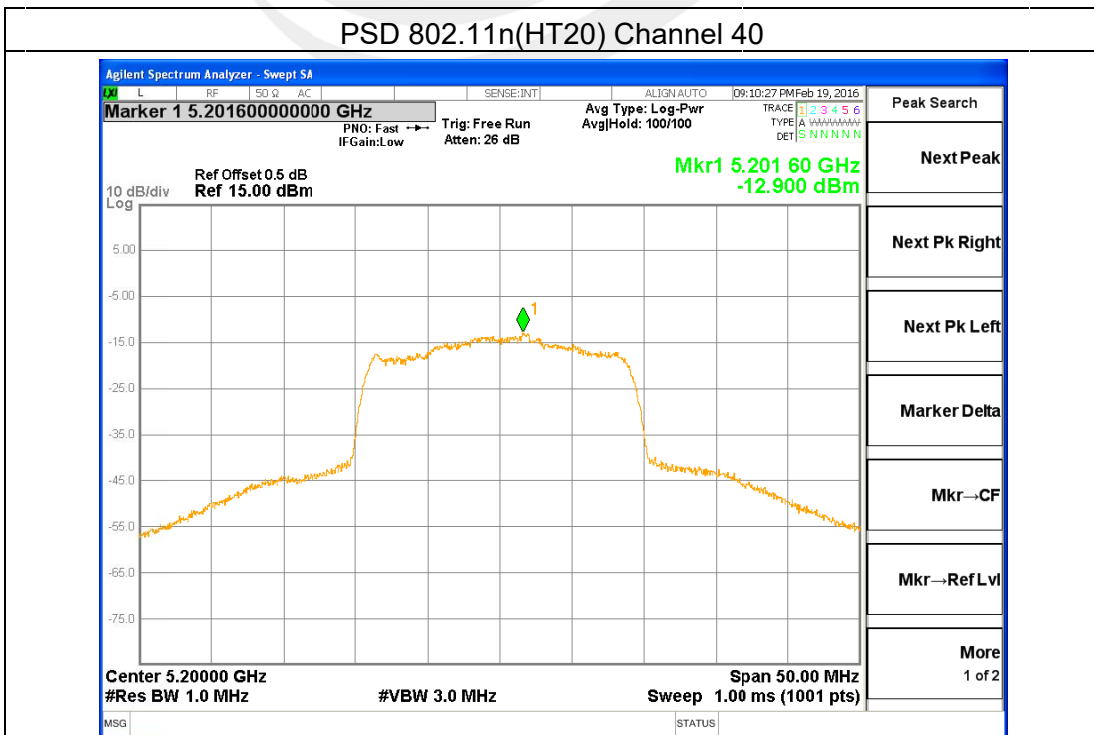
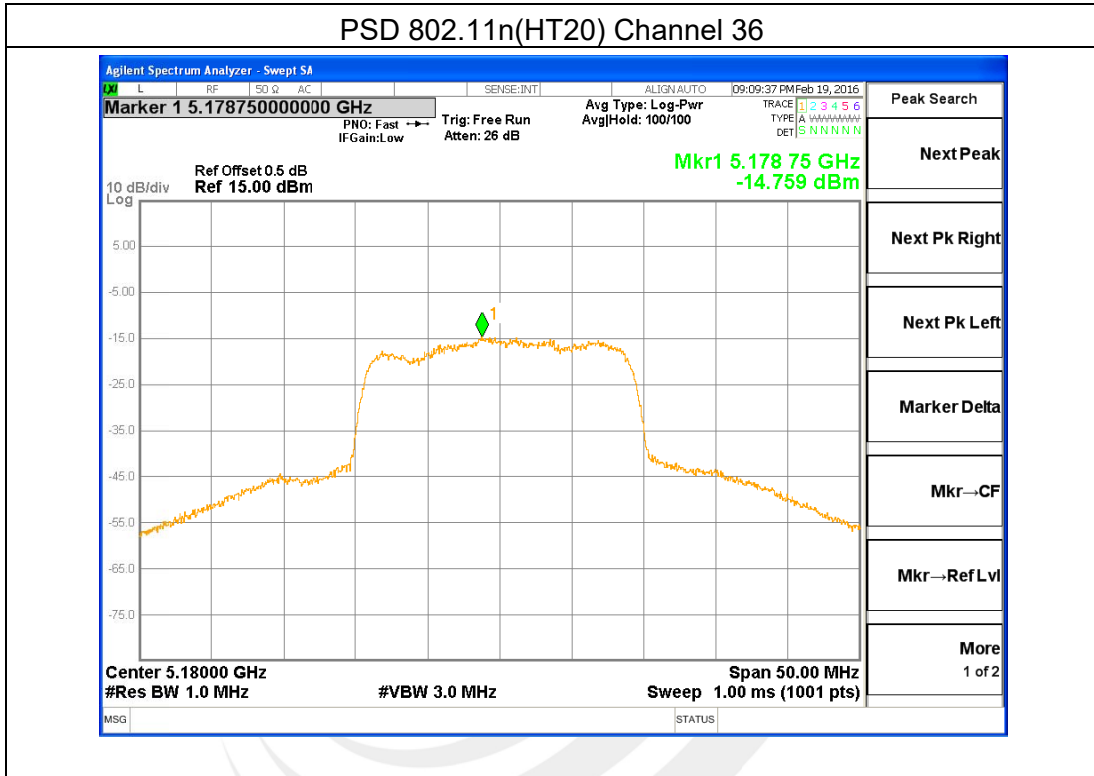

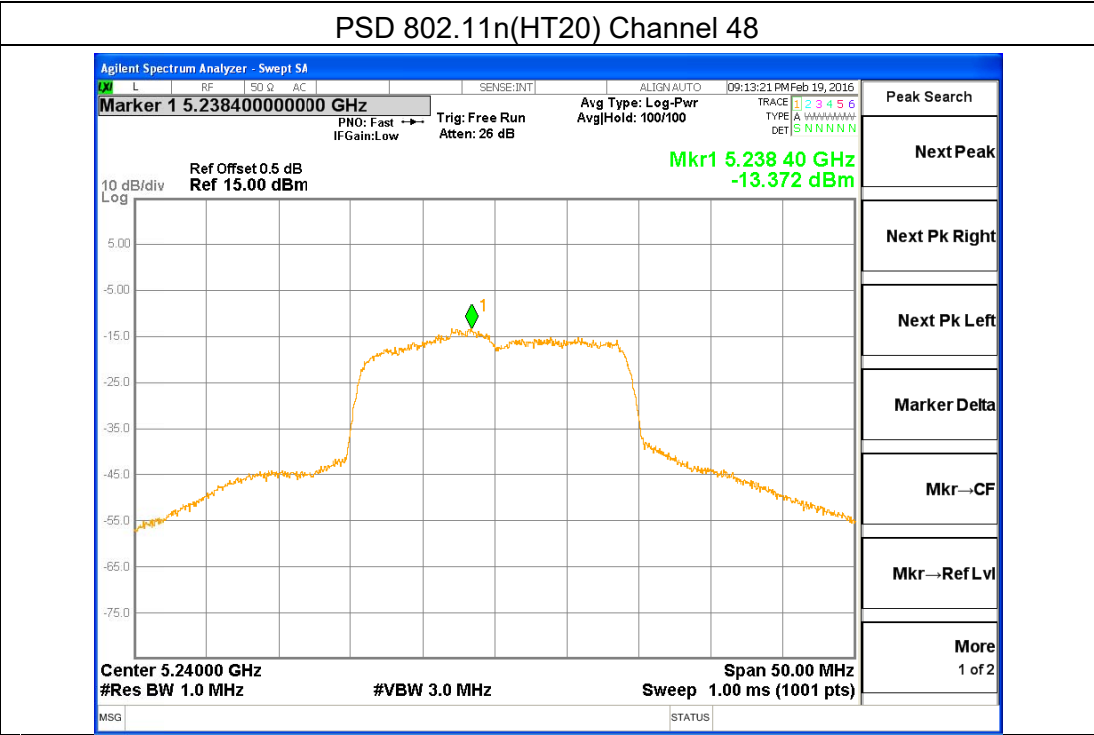



Band IV (5.725-5.850GHz)802.11a

Frequency	Power Density (dBm)	Limit (dBm)	Result
5745	-16.11	30	PASS
5785	-14.96	30	PASS
5825	-14.62	30	PASS

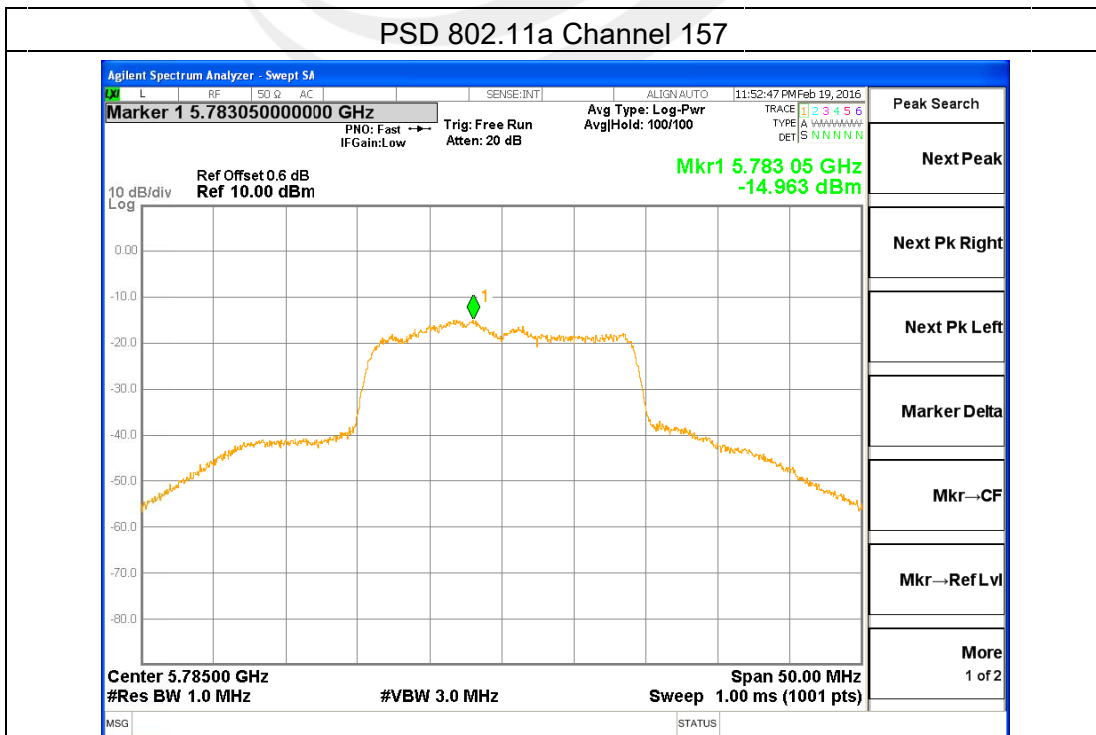
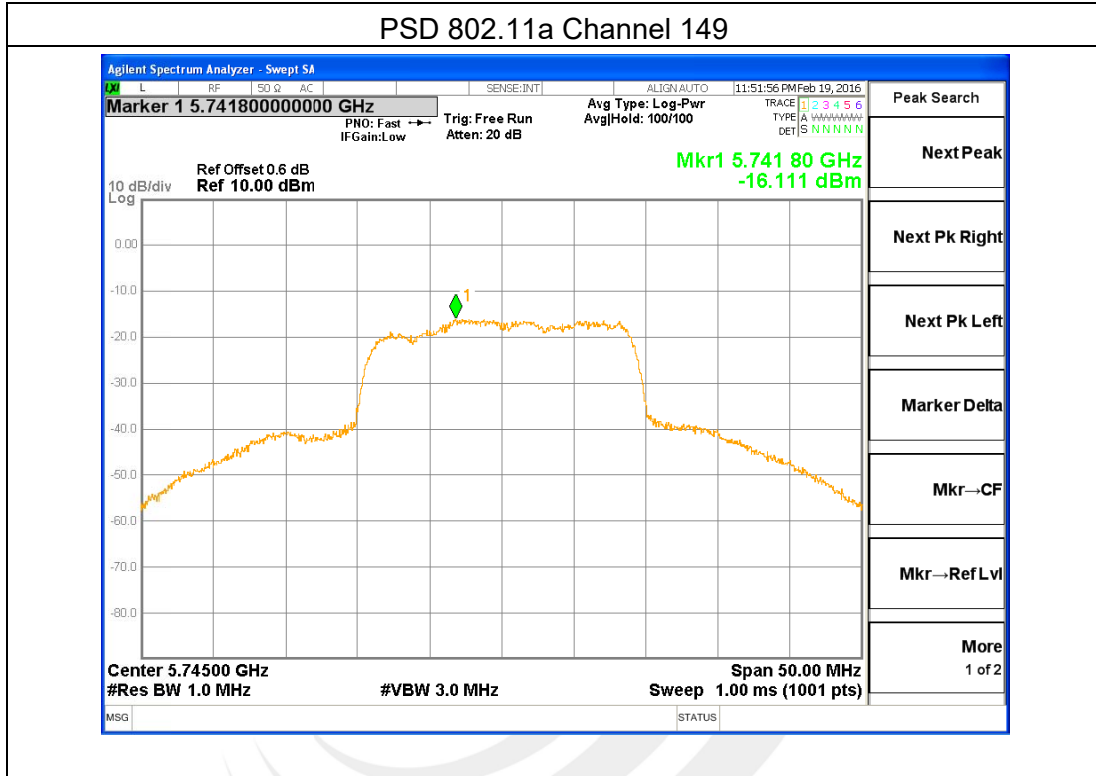

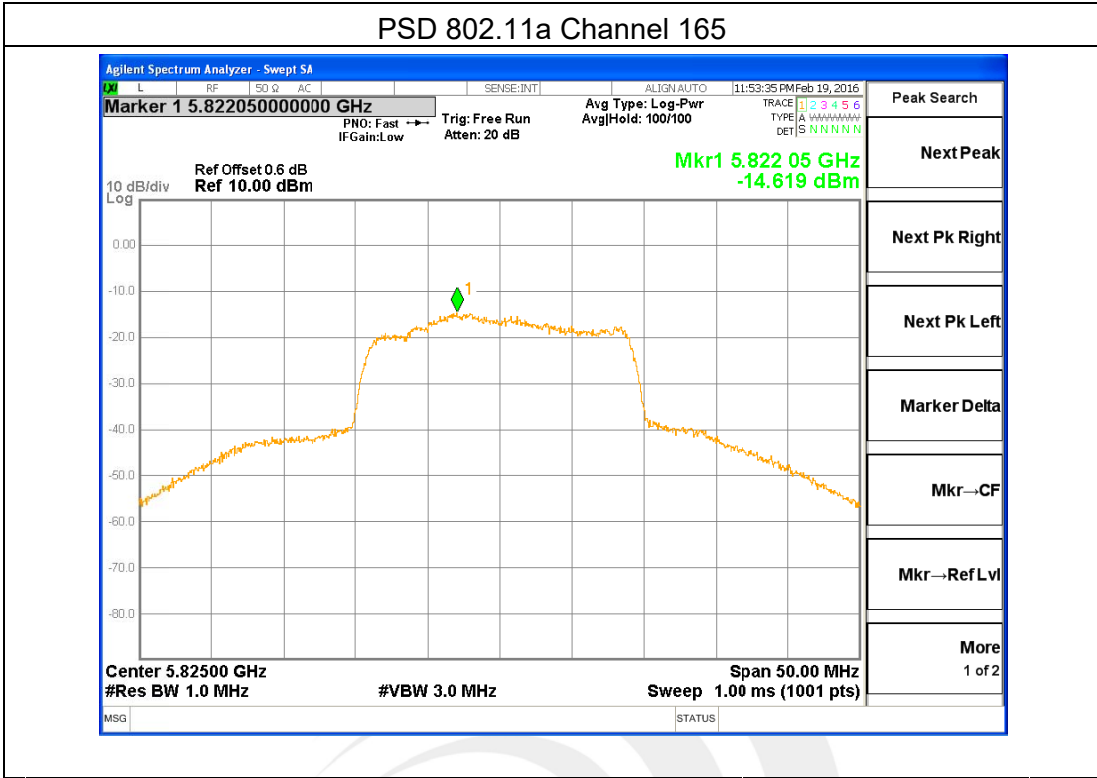



Band IV (5.725-5.850GHz)802.11n(HT20)

Frequency	Power Density (dBm)	Limit (dBm)	Result
5745	-14.90	30	PASS
5785	-14.83	30	PASS
5825	-15.46	30	PASS

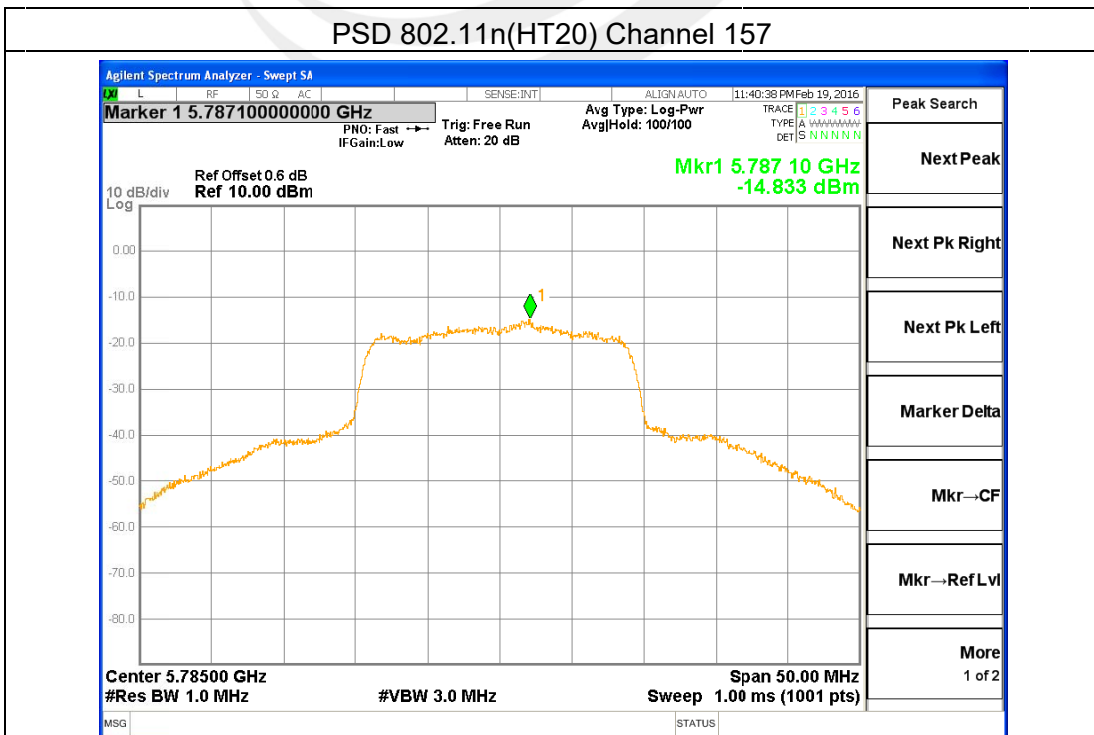
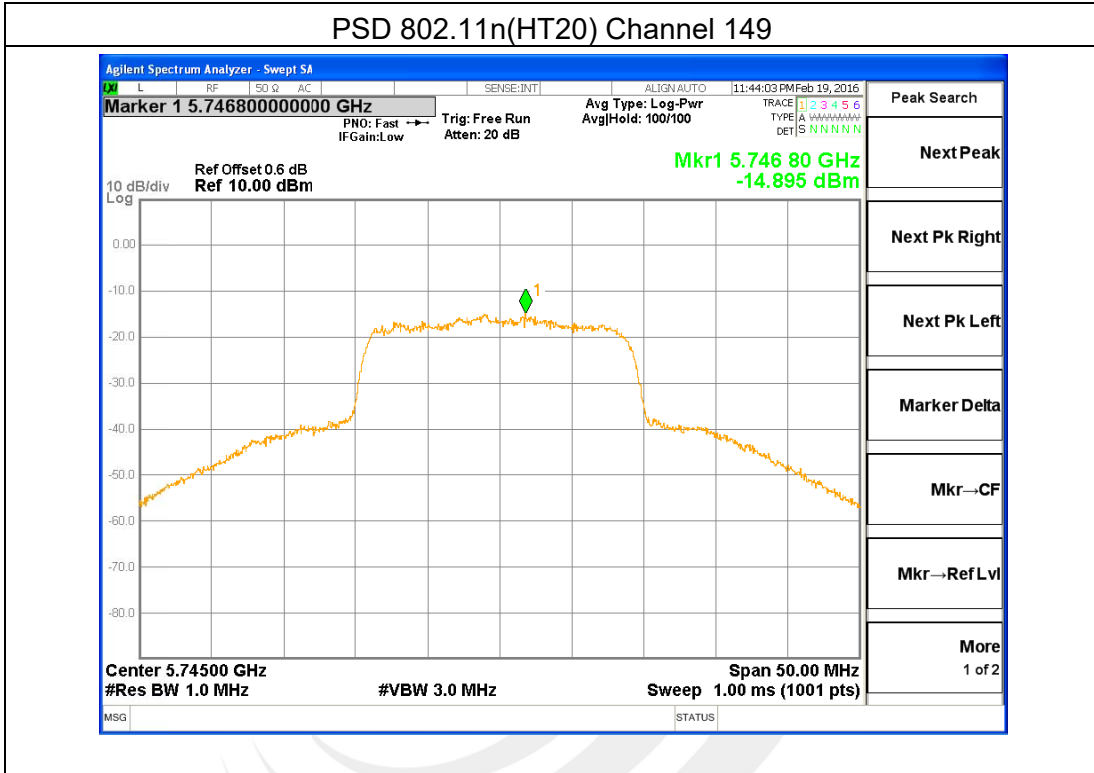

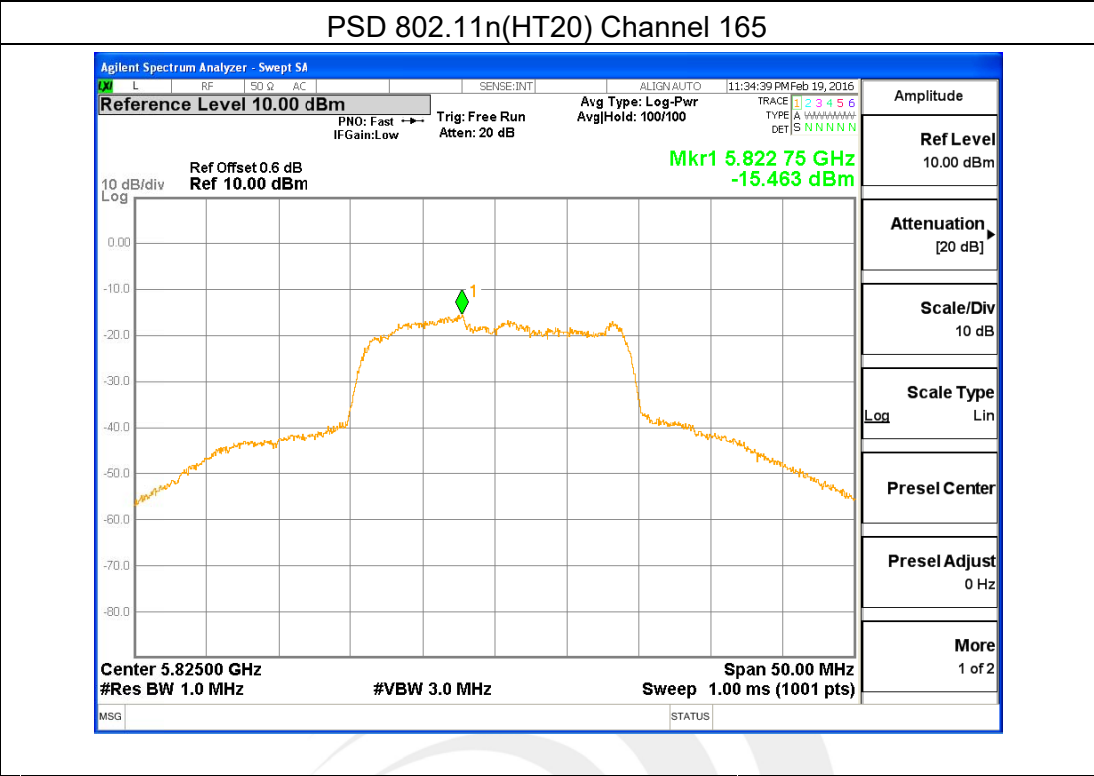

6. BANDWIDTH MEASUREMENT

6.1 EMISSION BANDWIDTH (EBW) 26 BANDWID PROCEDURES / LIMIT

See list of measuring instruments of this test report.

6.1.1 TEST PROCEDURE

1. The testing follows FCC KDB 789033 D02 General UNII Test Procedures New Rules v01r01
2. Set RBW = approximately 1% of the emission bandwidth.
3. Set the VBW \geq RBW.
4. Detector = Peak.
5. Trace mode = max hold.
6. Measure the maximum width of the emission that is 26 dB down from the peak of the emission. Compare this with the RBW setting of the analyzer. Readjust RBW and repeat measurement as needed until the RBW/EBW ratio is approximately 1%.

6.1.2 DEVIATION FROM STANDARD

No deviation.

6.1.3 TEST SETUP

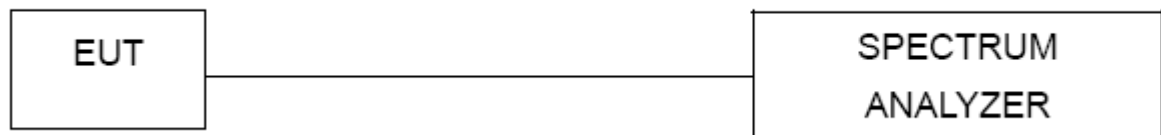

6.1.4 EUT OPERATION CONDITIONS

The EUT tested system was configured as the statements of 2.4 Unless otherwise a special operating condition is specified in the follows during the testing.



6.1.5 TEST RESULTS

Band I (5.150-5.250GHz)

Frequency (MHz)	802.11a 26dB Bandwidth(MHz)	Pass/Fail
5180	22.36	N/A
5200	22.76	N/A
5240	23.67	N/A

Note: N/A, 26 db bandwidth measurement limit only embodied in the report.

Frequency (MHz)	802.11n(HT20) 26dB Bandwidth(MHz)	Pass/Fail
5180	27.78	N/A
5200	25.30	N/A
5240	25.88	N/A

Note: N/A, 26 db bandwidth measurement limit only embodied in the report.

Band IV (5.725-5.850GHz)

Frequency (MHz)	802.11a 26dB Bandwidth(MHz)	Pass/Fail
5745	28.13	N/A
5785	31.49	N/A
5825	29.14	N/A

Note: N/A, 26 db bandwidth measurement limit only embodied in the report.

Frequency (MHz)	802.11n(HT20) 26dB Bandwidth(MHz)	Pass/Fail
5745	33.20	N/A
5785	32.71	N/A
5825	34.02	N/A

Note: N/A, 26 db bandwidth measurement limit only embodied in the report.

6.2 OCCUPIED BANDWIDTH (99%) TEST APPLIED PROCEDURES / LIMIT

The following procedure shall be used for measuring (99 %) power bandwidth:

6.2.1 TEST PROCEDURE

1. The testing follows FCC KDB 789033 D02 General UNII Test Procedures v01r01.

The following procedure shall be used for measuring (99 %) power bandwidth:

1. Set center frequency to the nominal EUT channel center frequency.
2. Set span = 1.5 times to 5.0 times the OBW.
3. Set RBW = 1 % to 5 % of the OBW
4. Set VBW $\geq 3 \cdot$ RBW
5. Video averaging is not permitted. Where practical, a sample detection and single sweep mode shall be used. Otherwise, peak detection and max hold mode (until the trace stabilizes) shall be used.
6. Use the 99 % power bandwidth function of the instrument (if available).
7. If the instrument does not have a 99 % power bandwidth function, the trace data points are recovered and directly summed in power units. The recovered amplitude data points, beginning at the lowest frequency, are placed in a running sum until 0.5 % of the total is reached; that frequency is recorded as the lower frequency. The process is repeated until 99.5 % of the total is reached; that frequency is recorded as the upper frequency. The 99% occupied bandwidth is the difference between these two frequencies.

6.2.2 DEVIATION FROM STANDARD

No deviation.

6.2.3 TEST SETUP



6.2.4 EUT OPERATION CONDITIONS

The EUT tested system was configured as the statements of 2.4 Unless otherwise a special operating condition is specified in the follows during the testing.



6.2.5 TEST RESULTS

Band I (5.150-5.250GHz)

Frequency (MHz)	802.11a 99% Bandwidth(MHz)	Pass/Fail
5180	17.165	N/A
5200	17.191	N/A
5240	17.140	N/A

Note: N/A, 99% bandwidth measurement limit only embodied in the report.

Frequency (MHz)	802.11n(HT20) 99% Bandwidth(MHz)	Pass/Fail
5180	18.137	N/A
5200	18.139	N/A
5240	18.187	N/A

Note: N/A, 99% bandwidth measurement limit only embodied in the report.

Band IV (5.725-5.850GHz)

Frequency (MHz)	802.11a 99% Bandwidth(MHz)	Pass/Fail
5745	17.352	N/A
5785	17.572	N/A
5825	17.496	N/A

Note: N/A, 99% bandwidth measurement limit only embodied in the report.

Frequency (MHz)	802.11n(HT20) 99% Bandwidth(MHz)	Pass/Fail
5745	18.534	N/A
5785	18.427	N/A
5825	18.365	N/A

Note: N/A, 99% bandwidth measurement limit only embodied in the report.

6.3 MINIMUM EMISSION BANDWIDTH(6 DB) PROCEDURES / LIMIT

Section 15.407(e) specifies the minimum 6 dB emission bandwidth of at least 500 KHz for the band 5.725-5.85 GHz. The following procedure shall be used for measuring this bandwidth:

6.3.1 TEST PROCEDURE

1. The testing follows FCC KDB 789033 D02 General UNII Test Procedures v01r01.
 - a) Set RBW = 100 kHz.
 - b) Set the video bandwidth (VBW) $\geq 3 \times$ RBW.
 - c) Detector = Peak.
 - d) Trace mode = max hold.
 - e) Sweep = auto couple.
 - f) Allow the trace to stabilize.
 - g) Measure the maximum width of the emission that is constrained by the frequencies associated with the two outermost amplitude points (upper and lower frequencies) that are attenuated by 6 dB relative to the maximum level measured in the fundamental emission.

6.3.2 DEVIATION FROM STANDARD

No deviation.

6.3.3 TEST SETUP



6.3.4 EUT OPERATION CONDITIONS

The EUT tested system was configured as the statements of 2.4 Unless otherwise a special operating condition is specified in the follows during the testing.



6.3.5 TEST RESULTS

Band IV (5.725-5.850GHz)

Frequency (MHz)	802.11n(HT20) 6dB Bandwidth(MHz)	Pass/Fail
5745	16.40	>500KHz
5785	16.40	>500KHz
5825	16.41	>500KHz

Note: N/A, 6 db bandwidth measurement limit only embodied in the report

Frequency (MHz)	802.11n(HT20) 6dB Bandwidth(MHz)	Pass/Fail
5745	17.62	>500KHz
5785	17.63	>500KHz
5825	17.63	>500KHz

Note: N/A, 6 db bandwidth measurement limit only embodied in the report

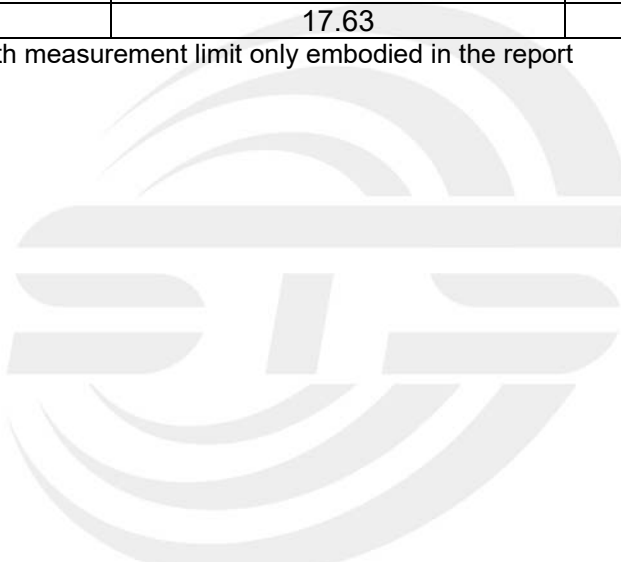



6.4 BANDWIDTH TEST POLT Band IV (5.725-5.850GHz) 802.11a

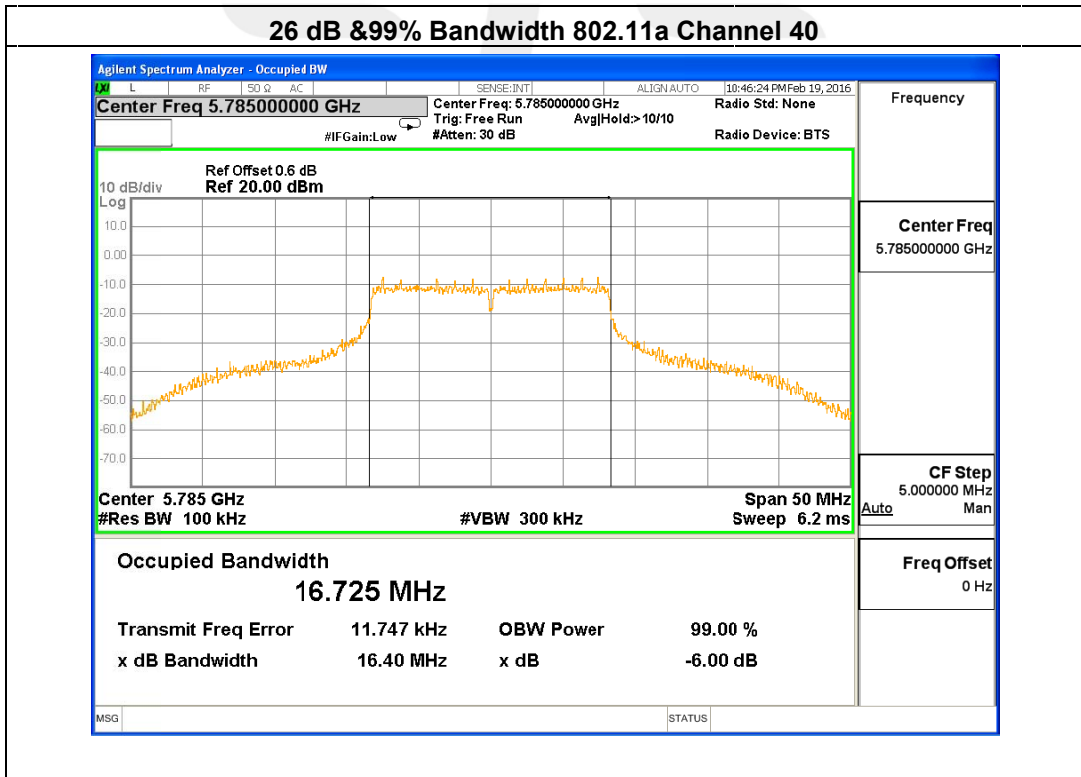
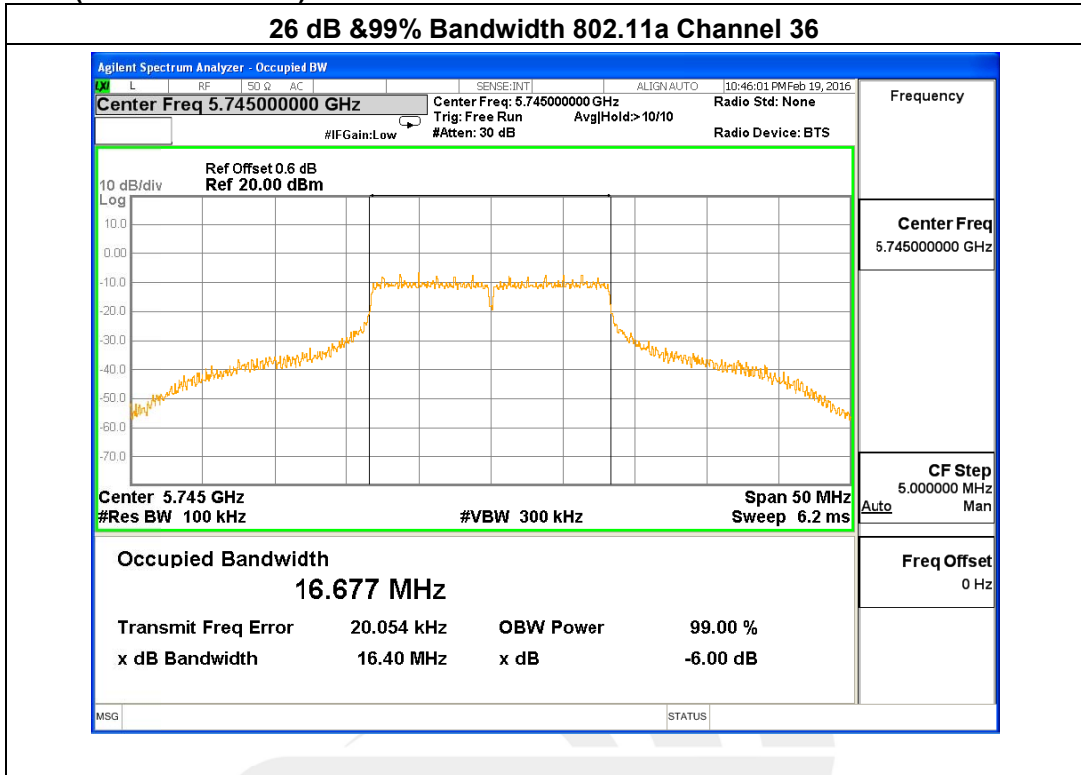

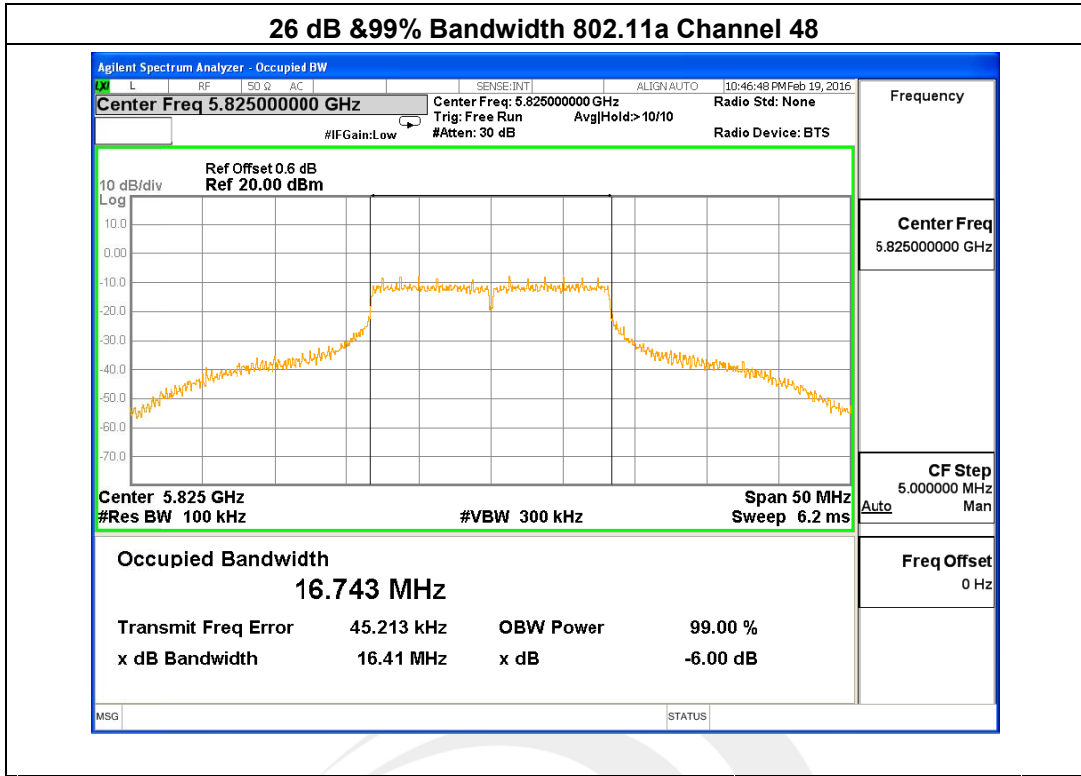



Band IV (5.725-5.850GHz) 802.11n(HT20)

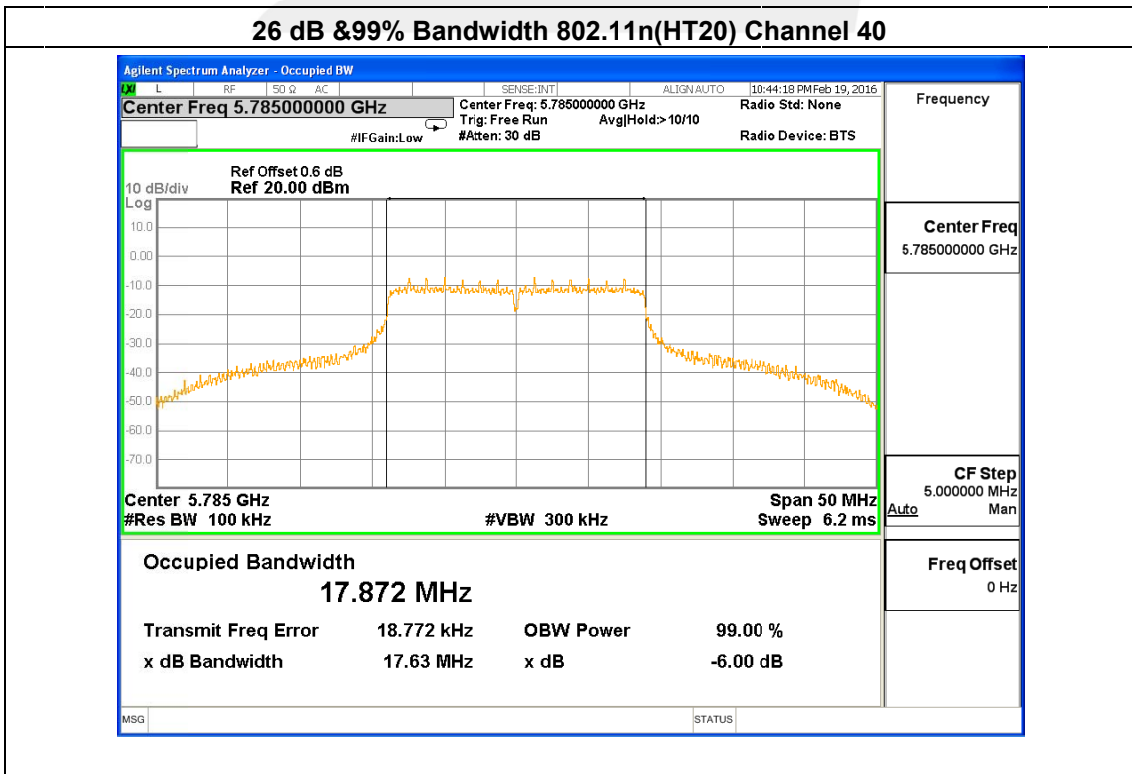
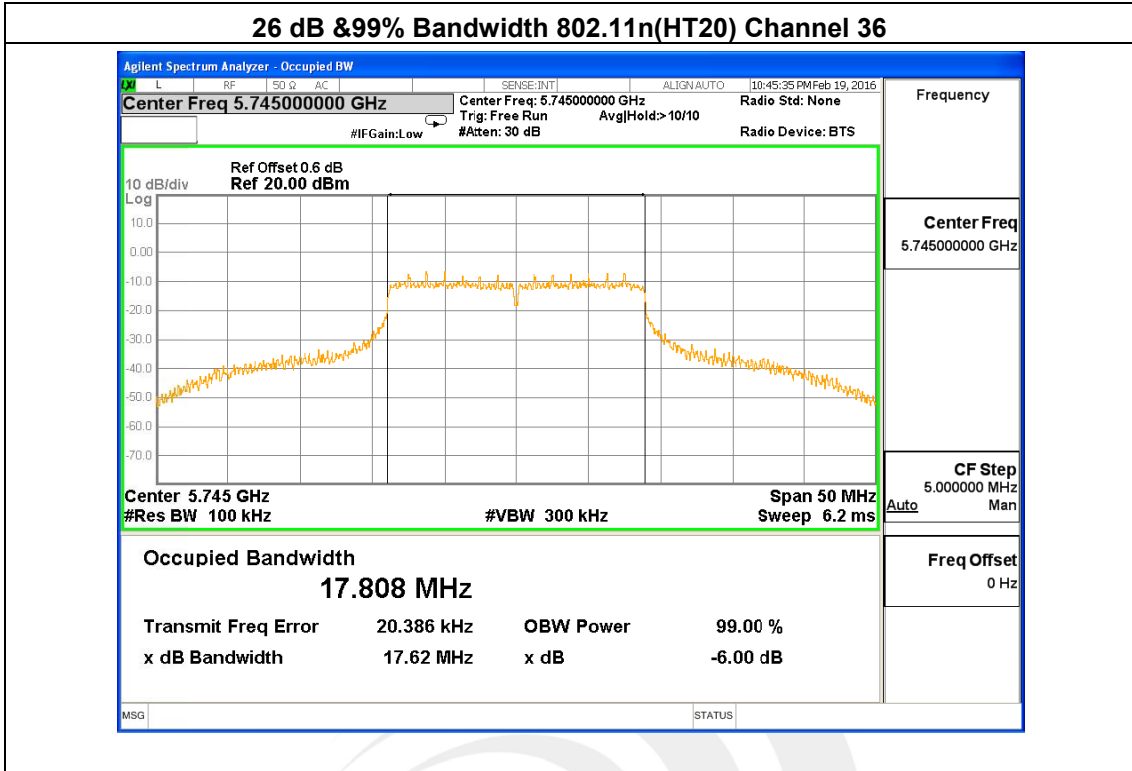

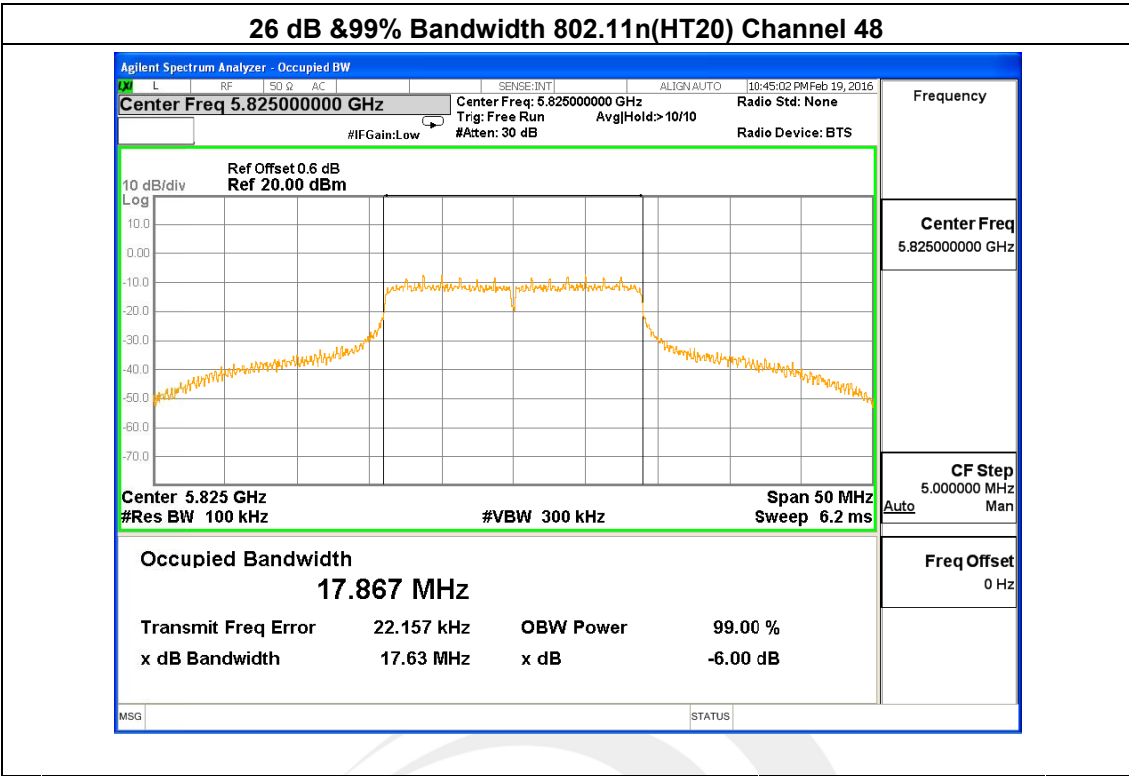



7. MAXIMUM CONDUCTED OUTPUT POWER

7.1 APPLIED PROCEDURES / LIMIT

For mobile and portable client devices in the 5.15-5.25 GHz band, the maximum conducted output power over the frequency band of operation shall not exceed 250 mW provided the maximum antenna gain does not exceed 6 dBi. In addition, the maximum power spectral density shall not exceed 11 dBm in any 1 megahertz band. If transmitting antennas of directional gain greater than 6 dBi are used, both the maximum conducted output power and the maximum power spectral density shall be reduced by the amount in dB that the directional gain of the antenna exceeds 6 dBi.

For the band 5.725-5.85 GHz, the maximum conducted output power over the frequency band of operation shall not exceed 1 W. In addition, the maximum power spectral density shall not exceed 30 dBm in any 500-kHz band. If transmitting antennas of directional gain greater than 6 dBi are used, both the maximum conducted output power and the maximum power spectral density shall be reduced by the amount in dB that the directional gain of the antenna exceeds 6 dBi. However, fixed point-to-point U-NII devices operating in this band may employ transmitting antennas with directional gain greater than 6 dBi without any corresponding reduction in transmitter conducted power. Fixed, point-to-point operations exclude the use of point-to-multipoint systems, omnidirectional applications, and multiple collocated transmitters transmitting the same information. The operator of the U-NII device, or if the equipment is professionally installed, the installer, is responsible for ensuring that systems employing high gain directional antennas are used exclusively for fixed, point-to-point operations.

FCC Part15 (15.407) , Subpart E

Section	Test Item	Limit	Frequency Range (MHz)	Result
15.407(a) (1) (iv)	Peak Output Power	0.25 watt	5150-5250	PASS
15.407(a) (3)		1 watt	5725-5825	

7.1.1 TEST PROCEDURE

The EUT was directly connected to the Power Sensor&Power meter

7.1.2 DEVIATION FROM STANDARD

No deviation.

7.1.3 TEST SETUP



7.1.4 EUT OPERATION CONDITIONS

The EUT tested system was configured as the statements of 5 Unless otherwise a special operating condition is specified in the follows during the testing.

7.1.5 TEST RESULTS

Band I (5.15-5.25GHz)

Test Channe	Frequency	Peak Power (dBm)	Average Power (dBm)	LIMIT
	(MHz)			dBm
802.11a				
36	5180	8.89	8.05	24.00
40	5200	8.85	8.00	24.00
48	5240	9.62	8.96	24.00
802.11n(HT20)				
36	5180	8.53	7.96	24.00
40	5200	8.99	8.21	24.00
48	5240	9.67	8.99	24.00

Note:

1. For mobile and portable client devices in the 5.15-5.25 GHz band, the maximum conducted output power over the frequency band of operation shall not exceed the lesser of 0.25 W.

Band IV (5.725-5.85GHz)

Test Channe	Frequency	Peak Power (dBm)	Average Power (dBm)	LIMIT
	(MHz)			dBm
802.11a				
149	5745	7.25	6.36	30.00
157	5785	7.63	7.12	30.00
161	5825	7.56	7.24	30.00
802.11n(HT20)				
149	5745	6.88	6.35	30.00
157	5785	7.24	6.78	30.00
161	5825	7.26	6.54	30.00

Note:

1. For the band 5.745-5.850 GHz, the maximum conducted output power over the frequency band of operation shall not exceed the lesser of 1 W.

8. FREQUENCY STABILITY MEASUREMENT

8.1 LIMIT OF FREQUENCY STABILITY

Manufacturers of U-NII devices are responsible for ensuring frequency stability such that an Emission is maintained within the band of operation under all conditions of normal operation as specified in the user's manual.

8.1.1 MEASURING INSTRUMENTS

See list of measuring instruments of this test report.

8.1.2 TEST PROCEDURES

1. To ensure emission at the band edge is maintained within the authorized band, those values shall be measured by radiation emissions at upper and lower frequency points, and finally compensated by frequency deviation as procedures below.
2. The EUT was operated at the maximum output power, and connected to the spectrum analyzer, which is set to maximum hold function and peak detector. The peak value of the power envelope was measured and noted. The upper and lower frequency points were respectively measured relatively 10dB lower than the measured peak value.
3. The frequency deviation was calculated by adding the upper frequency point and the lower frequency point divided by two. Those detailed values of frequency deviation are provided in table below.

8.1.3 TEST SETUP



**8.1.4 TEST RESULTS**

Voltage	Band I (5.15-5.25GHz) Measurement Frequency(MHz)
(V)	5200
126.50	5199.9645
110.00	5199.9442
93.50	5199.9442
Max.Deviation(MHz)	0.0558
Max.Deviation(ppm)	10.7

Temperature Vs. Frequency Stability:

Temperature	Measurement Frequency(MHz)
(°C)	5200
-30	5199.9578
-20	5199.9589
-10	5199.9543
0	5199.9567
10	5199.9568
20	5199.9579
30	5199.9568
40	5199.9579
50	5199.9569
Max.Deviation(MHz)	0.0457
Max.Deviation(ppm)	8.79



Voltage	Band IV (5.725-5.85GHz) Measurement Frequency(MHz)
(V)	5785
126.50	5784.9565
110.00	5784.9546
93.50	5784.9532
Max.Deviation(MHz)	0.0468
Max.Deviation(ppm)	9.00

Temperature Vs. Frequency Stability:

Temperature	Measurement Frequency(MHz)
(°C)	5785
-30	5785.9653
-20	5785.9642
-10	5785.9667
0	5785.9648
10	5785.9625
20	5785.9641
30	5785.9667
40	5785.9665
50	5785.9663
Max.Deviation(MHz)	0.9667
Max.Deviation(ppm)	1

9. AUTOMATICALLY DISCONTINUE TRANSMISSION

9.1 LIMIT OF AUTOMATICALLY DISCONTINUE TRANSMISSION

The device shall automatically discontinue transmission in case of either absence of information to transmit or operational failure. These provisions are not intended to preclude the transmission of control or signaling information or the use of repetitive codes used by certain digital technologies to complete frame or burst intervals. Applicants shall include in their application for equipment authorization to describe how this requirement is met.

9.2 TEST RESULT OF AUTOMATICALLY DISCONTINUE TRANSMISSION

During no any information transmission, the EUT can automatically discontinue transmission and become standby mode for power saving. The EUT can detect the controlling signal of ACK message transmitting from remote device and verify whether it shall resend or discontinue transmission





10. ANTENNA REQUIREMENT

10.1 STANDARD REQUIREMENT

15.203 requirement: For intentional device, according to 15.203: an intentional radiator shall be designed to ensure that no antenna other than that furnished by the responsible party shall be used with the device.

10.2 EUT ANTENNA

The EUT antenna is PIFA Antenna. It comply with the standard requirement.



APPENDIX - PHOTOS OF TEST SETUP

Radiated Measurement Photos

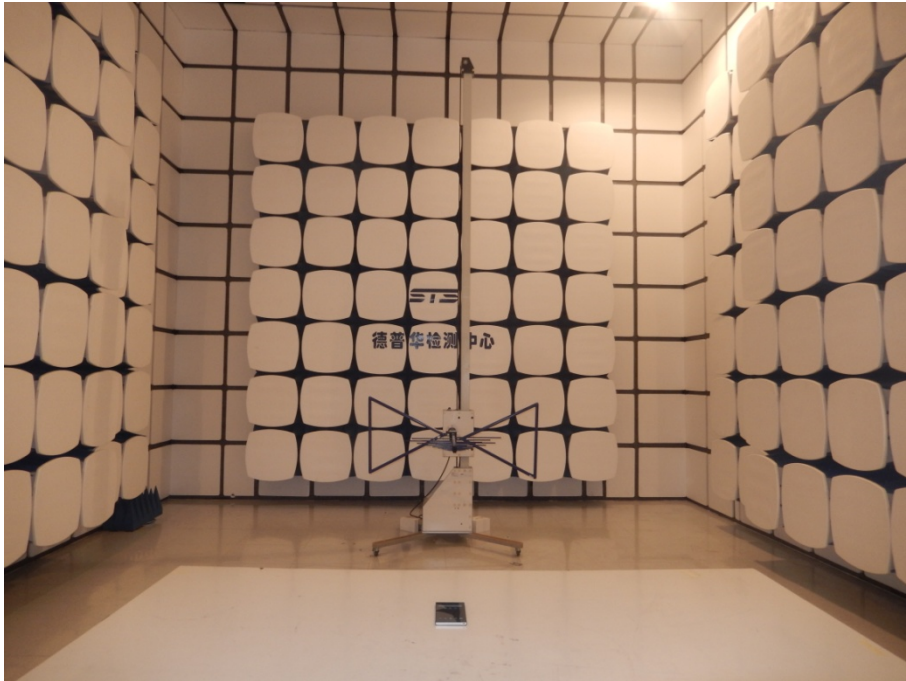

Conducted Measurement Photos

