

## FCC PART 15 SUBPART C TEST REPORT

### FCC PART 15.247

**Report Reference No.**.....: **MTWC21110851-R2**

**FCC ID**.....: **2ABD3-MA800F**

Compiled by

( position+printed name+signature) .: File administrators Alisa Luo

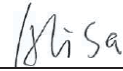

Supervised by

( position+printed name+signature) .: Test Engineer Sunny Deng



Approved by

( position+printed name+signature) .: Manager Yvette Zhou

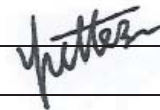

Date of issue .....: 2021.11.18

**Representative Laboratory Name.:** **Shenzhen Most Technology Service Co., Ltd.**

Address .....: No.5, 2nd Langshan Road, North District, Hi-tech Industrial Park,  
Nanshan, Shenzhen, Guangdong, China.

**Applicant's name**.....: **Ocean Digital Technology Ltd.**

Address .....: Flat B, 12/F., Yeung Yiu Chung (No.8) Ind. Bldg., 20 Wang Hoi  
Road, Kowloon Bay, Hong Kong.

**Test specification** .....

Standard.....: **FCC Part 15.247**

TRF Originator.....: Shenzhen Most Technology Service Co., Ltd.

**Shenzhen Most Technology Service Co., Ltd. All rights reserved.**

This publication may be reproduced in whole or in part for non-commercial purposes as long as the Shenzhen Most Technology Service Co., Ltd. is acknowledged as copyright owner and source of the material. Shenzhen Most Technology Service Co., Ltd. takes no responsibility for and will not assume liability for damages resulting from the reader's interpretation of the reproduced material due to its placement and context.

**Test item description** .....

Trade Mark .....: N/A

Manufacturer .....: Ocean Digital Technology Ltd.

Model/Type reference .....: MA-800F

Listed Models .....: WR-800F, MA-800, WR-800

Modulation Type.....: CCK/DSSS/ OFDM

Operation Frequency.....: From 2412 - 2462MHz

Rating .....: DC 9V by Adapter

Hardware version .....: V2.0

Software version .....: (APP:20200304.1159)

Result .....: **PASS**

## TEST REPORT

Equipment under Test : Internet Radio

Model /Type : MA-800F

Listed Models : WR-800F, MA-800, WR-800

Remark : Only different in model name and appearance

**Applicant** : **Ocean Digital Technology Ltd.**

Address : Flat B, 12/F., Yeung Yiu Chung (No.8) Ind. Bldg., 20 Wang Hoi Road, Kowloon Bay, Hong Kong.

**Manufacturer** : **Ocean Digital Technology Ltd.**

Address : Flat B, 12/F., Yeung Yiu Chung (No.8) Ind. Bldg., 20 Wang Hoi Road, Kowloon Bay, Hong Kong.

<b>Test Result:</b>	<b>PASS</b>
---------------------	-------------

The test report merely corresponds to the test sample.  
It is not permitted to copy extracts of these test result without the written permission of the test laboratory.

## Contents

<b>1 REVISION HISTORY .....</b>	<b>4</b>
<b>2 TEST STANDARDS.....</b>	<b>5</b>
<b>3 SUMMARY.....</b>	<b>6</b>
3.1 General Remarks .....	6
3.2 Product Description .....	6
3.3 Equipment Under Test .....	6
3.4 Short description of the Equipment under Test (EUT) .....	6
3.5 EUT operation mode .....	6
3.6 Block Diagram of Test Setup .....	7
3.7 Test Item (Equipment Under Test) Description* .....	7
3.8 Auxiliary Equipment (AE) Description .....	7
3.9 Related Submittal(s) / Grant (s).....	7
3.10 Modifications .....	7
<b>4 TEST ENVIRONMENT .....</b>	<b>8</b>
4.1 Address of the test laboratory .....	8
4.2 Test Facility.....	8
4.3 Environmental conditions .....	8
4.4 Test Description .....	9
4.5 Statement of the measurement uncertainty .....	9
4.6 Equipments Used during the Test .....	10
<b>5 TEST CONDITIONS AND RESULTS.....</b>	<b>11</b>
5.1 AC Power Conducted Emission.....	11
5.2 Radiated Emission .....	14
5.3 Maximum Conducted Output Power .....	21
5.4 Power Spectral Density.....	22
5.5 6dB Bandwidth .....	25
5.6 Out-of-band Emissions .....	28
5.7 Antenna Requirement .....	33
<b>6 TEST SETUP PHOTOS OF THE EUT .....</b>	<b>34</b>
<b>7 PHOTOS OF THE EUT .....</b>	<b>35</b>

## 1 Revision History

Revision	Issue Date	Revisions	Revised By
00	2021.11.18	Initial Issue	Alisa Luo

## **2 TEST STANDARDS**

The tests were performed according to following standards:

[FCC Rules Part 15.247](#): Frequency Hopping, Direct Spread Spectrum and Hybrid Systems that are in operation within the bands of 902-928 MHz, 2400-2483.5 MHz, and 5725-5850 MHz.

[ANSI C63.10-2013](#): American National Standard for Testing Unlicensed Wireless Devices

[KDB558074 D01 v05r02](#): Guidance for Compliance Measurements on Digital Transmission Systems (DTS) ,Frequency Hopping Spread Spectrum System(HFSS), and Hybrid System Devices Operating Under §15.247 of The FCC rules.

### 3 SUMMARY

#### 3.1 General Remarks

Date of receipt of test sample	:	2021.11.08
		2021.11.10
Testing commenced on	:	2021.11.17
		2021.11.08
Testing concluded on	:	

#### 3.2 Product Description

Product Name:	Internet Radio
Model/Type reference:	MA-800F
Power Supply:	DC 9V by Adapter
Testing sample ID:	MT21100180
<b>WIFI :</b>	
Supported type:	802.11b/802.11g/802.11n(H20)
Modulation:	802.11b: DSSS 802.11g/802.11n(H20): OFDM
Operation frequency:	802.11b/802.11g/802.11n(H20): 2412MHz~2462MHz
Channel number:	802.11b/802.11g/802.11n(H20): 11
Channel separation:	5MHz
Antenna type:	PCB antenna
Antenna gain:	0 dBi

#### 3.3 Equipment Under Test

##### Power supply system utilised

Power supply voltage	:	<input type="radio"/> 230V / 50 Hz	<input checked="" type="radio"/> 120V / 60Hz
		<input type="radio"/> 12 V DC	<input type="radio"/> 24 V DC
		<input type="radio"/> Other (specified in blank below)	

DC 9V by Adapter

#### 3.4 Short description of the Equipment under Test (EUT)

This is a Internet Radio.

For more details, refer to the user's manual of the EUT.

#### 3.5 EUT operation mode

The application provider specific test software(AT command) to control sample in continuous TX and RX (Duty Cycle >98%) for testing meet KDB558074 test requirement.

IEEE 802.11b/g/n: Thirteen channels are provided to the EUT.

Channel	Frequency(MHz)	Channel	Frequency(MHz)
1	2412	8	2447
2	2417	9	2452
3	2422	10	2457
4	2427	11	2462
5	2432		
6	2437		
7	2442		

### 3.6 Block Diagram of Test Setup

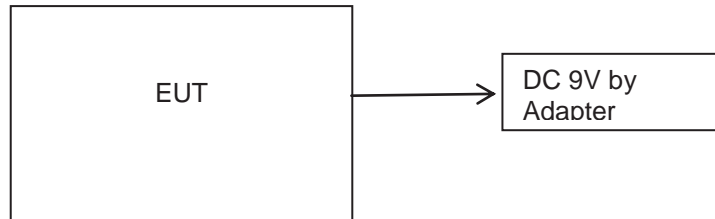

### 3.7 Test Item (Equipment Under Test) Description\*

Short designation	EUT Name	EUT Description	Serial number	Hardware status	Software status
EUT A	/	/	/	/	/
EUT B	/	/	/	/	/

\*: declared by the applicant. According to customers information EUTs A and B are the same devices.

### 3.8 Auxiliary Equipment (AE) Description

AE short designation	EUT Name (if available)	EUT Description	Serial number (if available)	Software (if used)
AE 1	/	/	/	/
AE 2	/	/	/	/

### 3.9 Antenna Information\*

Short designation	Antenna Name	Antenna Type	Frequency Range	Serial number	Antenna Peak Gain
Antenna 1	---	PCB antenna	2.4 – 2.5 GHz	---	0 dbi
Antenna 2					

\*: declared by the applicant.

### 3.10 Related Submittal(s) / Grant (s)

This submittal(s) (test report) is intended for **FCC ID: 2ABD3-MA800F** filing to comply with Section 15.247 of the FCC Part 15, Subpart C Rules.

### 3.11 Modifications

No modifications were implemented to meet testing criteria.

## 4 TEST ENVIRONMENT

### 4.1 Address of the test laboratory

#### **Shenzhen Most Technology Service Co., Ltd.**

No.5, 2nd Langshan Road, North District, Hi-tech Industrial Park, Nanshan, Shenzhen, Guangdong, China.  
The 3m-Semi anechoic test site fulfils CISPR 16-1-4 according to ANSI C63.4:2014 and CISPR 16-1-4:2010 SVSWR requirement for radiated emission above 1GHz.

### 4.2 Test Facility

The test facility is recognized, certified, or accredited by the following organizations:

#### **FCC-Registration No.: 0031192610**

Shenzhen Most Technology Service Co., Ltd. EMC Laboratory has been registered and fully described in a report filed with the (FCC) Federal Communications Commission. The acceptance letter from the FCC is maintained in our files.

#### **A2LA-Lab Cert. No.: 6343.01**

Shenzhen Most Technology Service Co., Ltd. EMC Laboratory has been accredited by A2LA for technical competence in the field of electrical testing, and proved to be in compliance with ISO/IEC 17025: 2005 General Requirements for the Competence of Testing and Calibration Laboratories and any additional program requirements in the identified field of testing.

### 4.3 Environmental conditions

Radiated Emission:

Temperature:	24 ° C
Humidity:	48 %
Atmospheric pressure:	950-1050mbar

AC Main Conducted testing:

Temperature:	24 ° C
Humidity:	45 %
Atmospheric pressure:	950-1050mbar

Conducted testing:

Temperature:	24 ° C
Humidity:	45 %
Atmospheric pressure:	950-1050mbar



#### 4.4 Test Description

FCC PART 15.247		
FCC Part 15.207	AC Power Conducted Emission	PASS
FCC Part 15.247(a)(2)	6dB Bandwidth	PASS
FCC Part 15.247(d)	Spurious RF Conducted Emission	PASS
FCC Part 15.247(b)	Maximum Conducted Output Power	PASS
FCC Part 15.247(e)	Power Spectral Density	PASS
FCC Part 15.109/ 15.205/ 15.209	Radiated Emissions	PASS
FCC Part 15.247(d)	Band Edge	PASS
FCC Part 15.203/15.247 (b)	Antenna Requirement	PASS

#### Data Rate Used:

Preliminary tests were performed in different data rate to find the worst radiated emission. The data rate shown in the table below is the worst-case rate with respect to the specific test item. Investigation has been done on all the possible configurations for searching the worst cases. The following table is a list of the test modes shown in this test report.

Test Items	Mode	Data Rate	Channel
Maximum Peak Conducted Output Power Power Spectral Density 6dB Bandwidth Spurious RF conducted emission Radiated Emission 9KHz~1GHz& Radiated Emission 1GHz~10 <sup>th</sup> Harmonic	11b/DSSS	1 Mbps	1/6/11
	11g/OFDM	6 Mbps	1/6/11
	11n(20MHz)/OFDM	6.5Mbps	1/6/11
Band Edge	11b/DSSS	1 Mbps	1/11
	11g/OFDM	6 Mbps	1/11
	11n(20MHz)/OFDM	6.5Mbps	1/11

#### 4.5 Statement of the measurement uncertainty

The data and results referenced in this document are true and accurate. The reader is cautioned that there may be errors within the calibration limits of the equipment and facilities. The measurement uncertainty was calculated for all measurements listed in this test report acc. to CISPR 16 - 4 „Specification for radio disturbance and immunity measuring apparatus and methods – Part 4: Uncertainty in EMC Measurements“ and is documented in the Shenzhen Most Technology Service Co., Ltd. quality system acc. to DIN EN ISO/IEC 17025. Furthermore, component and process variability of devices similar to that tested may result in additional deviation. The manufacturer has the sole responsibility of continued compliance of the device.

Hereafter the best measurement capability for Shenzhen Most Technology Service Co., Ltd. is reported:

Test	Range	Measurement Uncertainty	Notes
Radiated Emission	30~1000MHz	4.10 dB	(1)
Radiated Emission	1~18GHz	4.32 dB	(1)
Radiated Emission	18-40GHz	5.54 dB	(1)
Conducted Disturbance	0.15~30MHz	3.12 dB	(1)

- (1) This uncertainty represents an expanded uncertainty expressed at approximately the 95% confidence level using a coverage factor of k=2.

#### 4.6 Equipments Used during the Test

Item	Equipment	Manufacturer	Model No.	Serial No.	Last Cal.	Cal. Interval
1.	L.I.S.N.	R&S	ENV216	100093	2021/04/19	1 Year
2	Three-phase artificial power network	Schwarzback Mess	NNLK8129	8129178	2021/04/19	1 Year
3.	Receiver	R&S	ESCI	100492	2021/04/7	1 Year
4	Receiver	R&S	ESPI	101202	2021/04/7	1 Year
5	Spectrum analyzer	Agilent	9020A	MT-E306	2021/04/7	1 Year
6	Bilong Antenna	Sunol Sciences	JB3	A121206	2021/03/14	1 Year
7	Horn antenna	HF Antenna	HF Antenna	MT-E158	2021/04/7	1 Year
8	Loop antenna	Beijing Daze	ZN30900B	/	2021/04/16	1 Year
9	Horn antenna	R&S	OBH100400	26999002	2021/04/16	1 Year
10	Wireless Communication Test Set	R&S	CMW500	/	2021/04/15	1 Year
11	Spectrum analyzer	R&S	FSP	100019	2021/04/15	1 Year
12	High gain antenna	Schwarzbeck	LB-180400KF	MT-E389	2021/03/14	1 Year
13	Preamplifier	Schwarzbeck	BBV 9743	MT-E390	2021/03/14	1 Year
14	Pre-amplifier	EMCI	EMC051845S E	MT-E391	2021/03/14	1 Year
15	Pre-amplifier	Agilent	83051A	MT-E392	2021/03/14	1 Year
16	High pass filter unit	Tonscend	JS0806-F	MT-E393	2021/03/14	1 Year
17	RF Cable(below1GHz)	Times	9kHz-1GHz	MT-E394	2021/03/14	1 Year
18	RF Cable(above 1GHz)	Times	1-40G	MT-E395	2021/03/14	1 Year
19	RF Cable (9KHz-40GHz)	Tonscend	170660	N/A	2021/03/14	1 Year

Note: The Cal.Interval was one year.

## 5 TEST CONDITIONS AND RESULTS

### 5.1 AC Power Conducted Emission

#### TEST CONFIGURATION

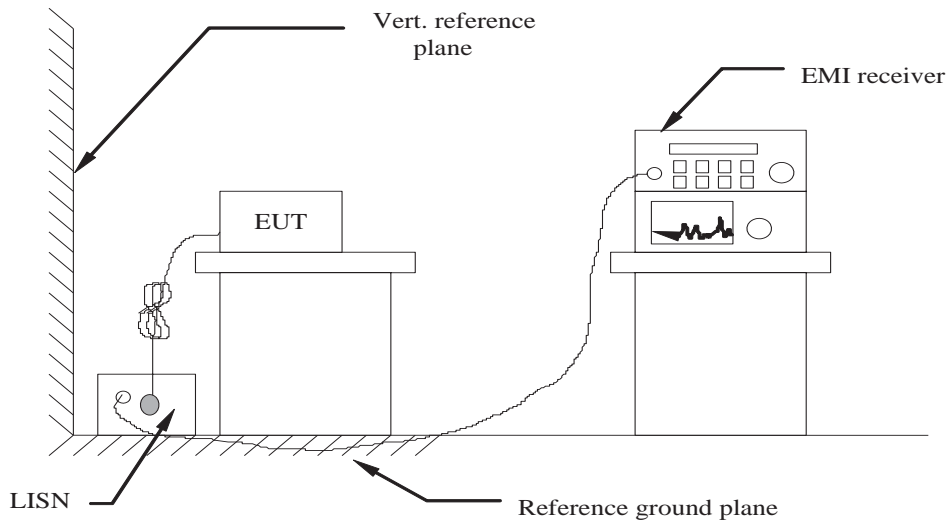

#### TEST PROCEDURE

- 1 The equipment was set up as per the test configuration to simulate typical actual usage per the user's manual. The EUT is a tabletop system, a wooden table with a height of 0.8 meters is used and is placed on the ground plane as per ANSI C63.10-2013.
- 2 Support equipment, if needed, was placed as per ANSI C63.10-2013
- 3 All I/O cables were positioned to simulate typical actual usage as per ANSI C63.10-2013
- 4 The EUT received DC 12V power from adapter, the adapter received AC120V/60Hz and AC 240V/60Hz power through a Line Impedance Stabilization Network (LISN) which supplied power source and was grounded to the ground plane.
- 5 All support equipments received AC power from a second LISN, if any.
- 6 The EUT test program was started. Emissions were measured on each current carrying line of the EUT using a spectrum Analyzer / Receiver connected to the LISN powering the EUT. The LISN has two monitoring points: Line 1 (Hot Side) and Line 2 (Neutral Side). Two scans were taken: one with Line 1 connected to Analyzer / Receiver and Line 2 connected to a 50 ohm load; the second scan had Line 1 connected to a 50 ohm load and Line 2 connected to the Analyzer / Receiver.
- 7 Analyzer / Receiver scanned from 150 KHz to 30MHz for emissions in each of the test modes.
- 8 During the above scans, the emissions were maximized by cable manipulation.

#### AC Power Conducted Emission Limit

For intentional device, according to § 15.207(a) AC Power Conducted Emission Limits is as following :

Frequency range (MHz)	Limit (dBuV)	
	Quasi-peak	Average
0.15-0.5	66 to 56*	56 to 46*
0.5-5	56	46
5-30	60	50

\* Decreases with the logarithm of the frequency.

**TEST RESULTS**

Remark:

1. All modes were test at Low, Middle, and High channel; only the worst result of 802.11b low channel was reported as below:
2. Both 120 VAC, 50/60 Hz and 240 VAC, 50/60 Hz power supply have been tested, only the worst result of 120 VAC, 60 Hz was reported as below:
3. Remark: Result=Reading value+Factor,and Margin=Limit- Result

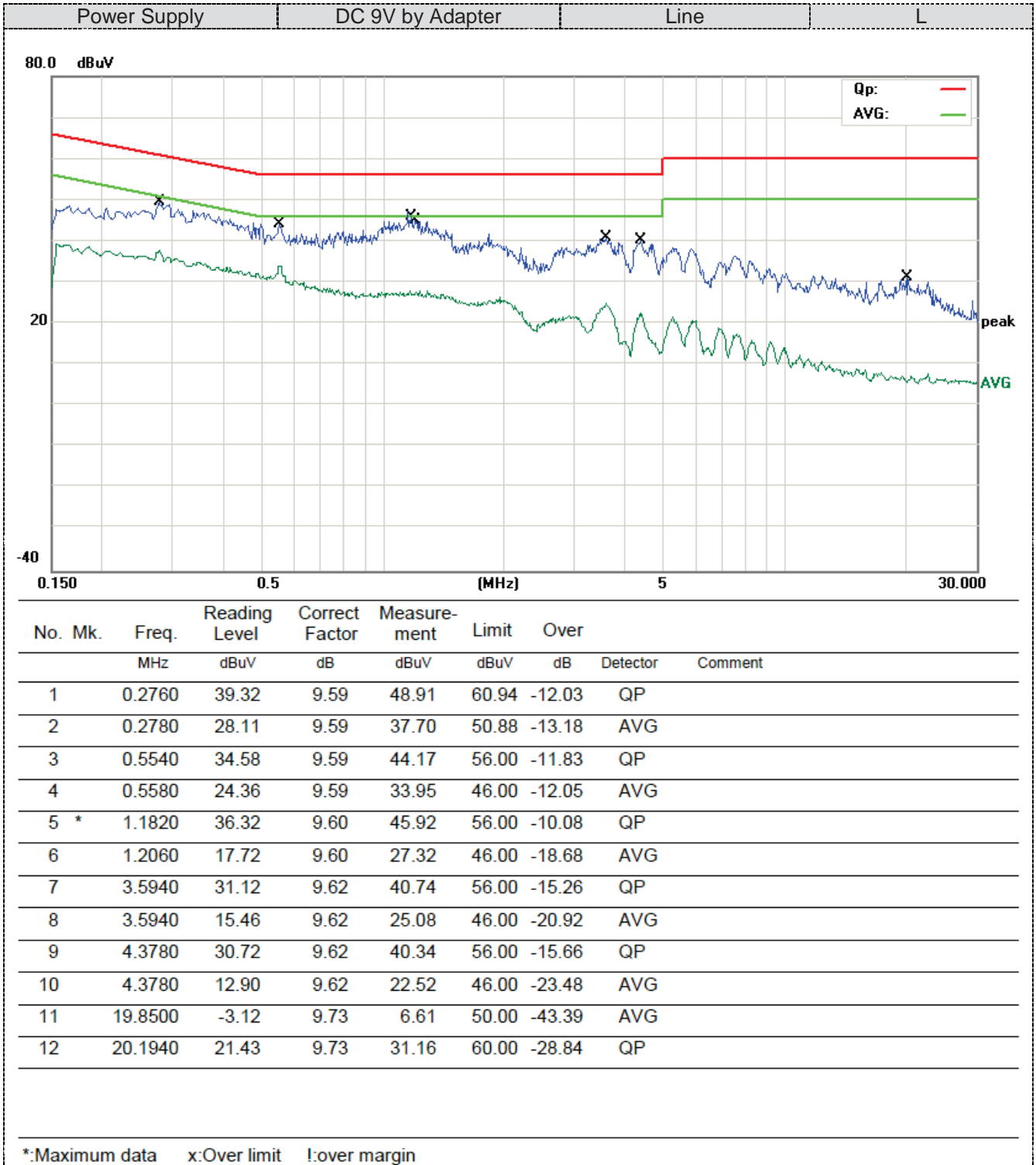

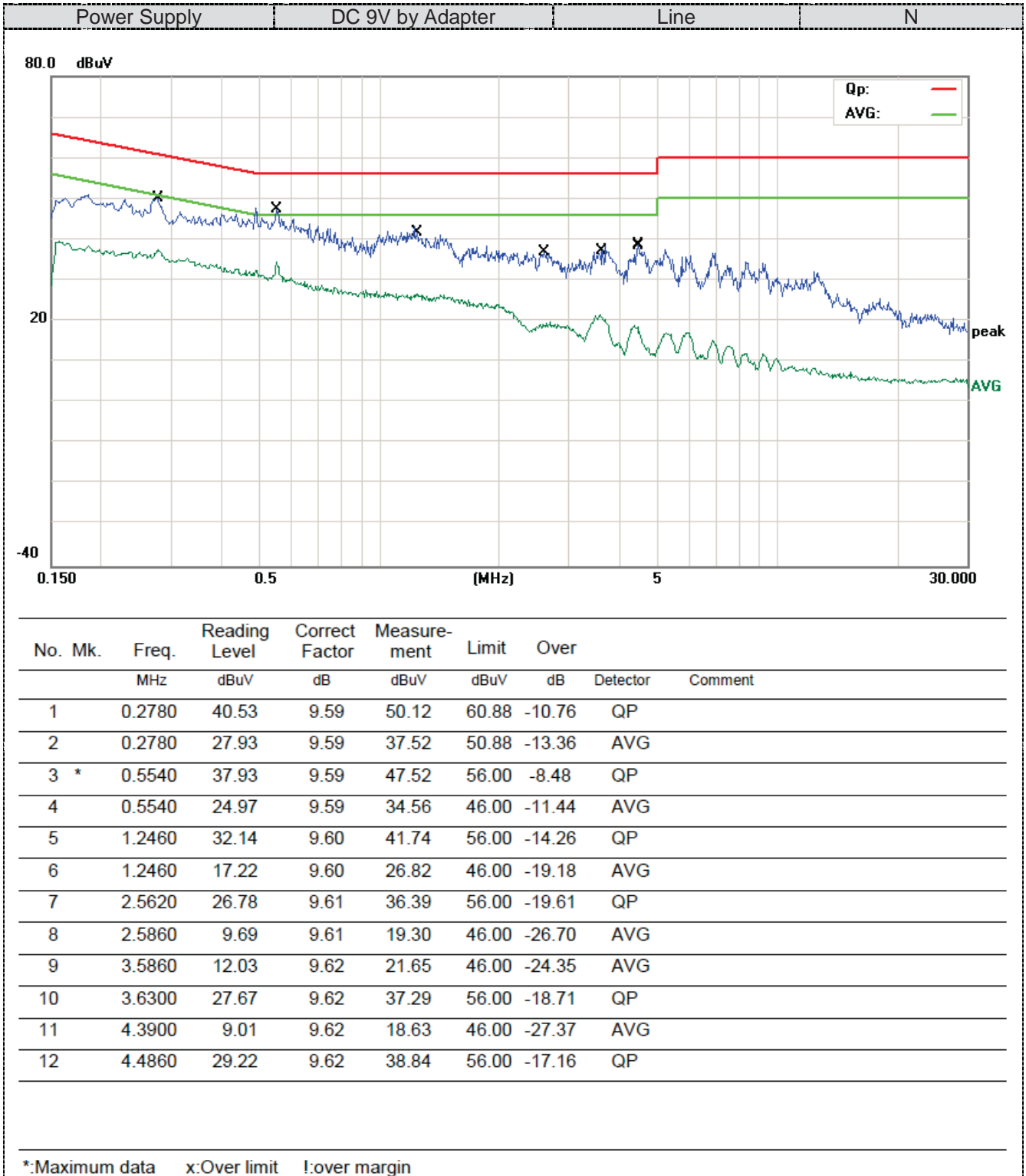

## 5.2 Radiated Emission

### TEST CONFIGURATION

Frequency range 9 KHz – 30MHz

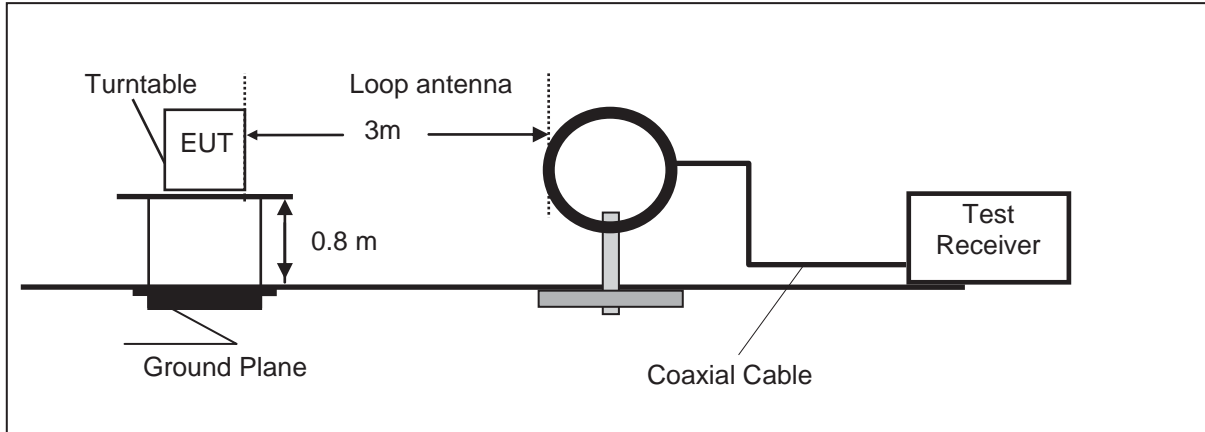

Frequency range 30MHz – 1000MHz

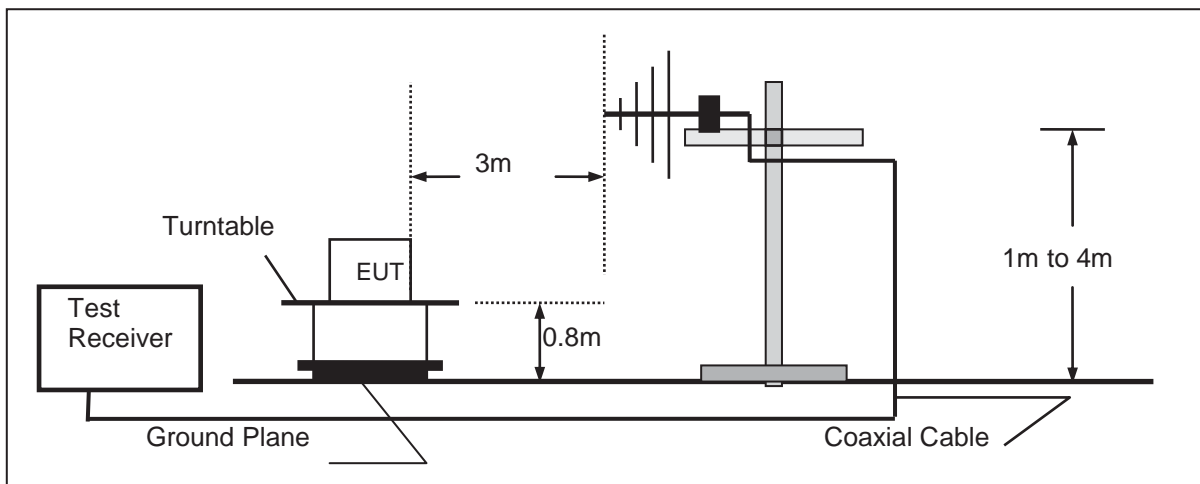

Frequency range above 1GHz-25GHz

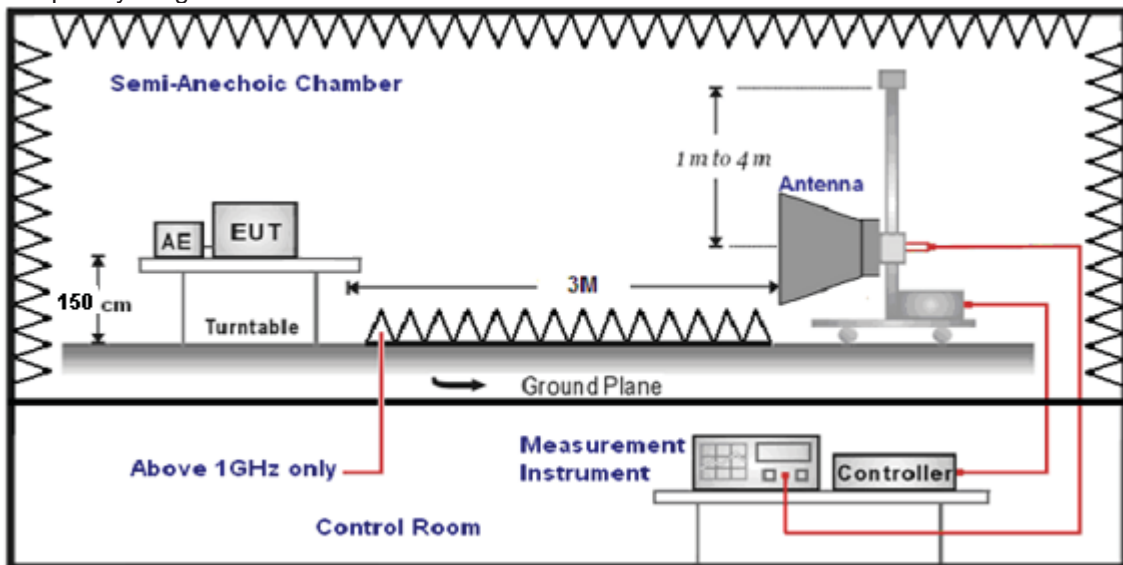

**TEST PROCEDURE**

1. The EUT was placed on a turn table which is 0.8m above ground plane when testing frequency range 9 KHz –1GHz;the EUT was placed on a turn table which is 1.5m above ground plane when testing frequency range 1GHz – 25GHz.
2. Maximum procedure was performed by raising the receiving antenna from 1m to 4m and rotating the turn table from 0° to 360° to acquire the highest emissions from EUT.
3. And also, each emission was to be maximized by changing the polarization of receiving antenna both horizontal and vertical.
4. Repeat above procedures until all frequency measurements have been completed.
5. Radiated emission test frequency band from 9KHz to 25GHz.
6. The distance between test antenna and EUT as following table states:

Test Frequency range	Test Antenna Type	Test Distance
9KHz-30MHz	Active Loop Antenna	3
30MHz-1GHz	Ultra-Broadband Antenna	3
1GHz-18GHz	Double Ridged Horn Antenna	3
18GHz-25GHz	Horn Antenna	1

7. Setting test receiver/spectrum as following table states:

Test Frequency range	Test Receiver/Spectrum Setting	Detector
9KHz-150KHz	RBW=200Hz/VBW=3KHz, Sweep time=Auto	QP
150KHz-30MHz	RBW=9KHz/VBW=100KHz, Sweep time=Auto	QP
30MHz-1GHz	RBW=120KHz/VBW=1000KHz, Sweep time=Auto	QP
1GHz-40GHz	Peak Value: RBW=1MHz/VBW=3MHz, Sweep time=Auto Average Value: RBW=1MHz/VBW=10Hz, Sweep time=Auto	Peak

**Field Strength Calculation**

The field strength is calculated by adding the Antenna Factor and Cable Factor and subtracting the Amplifier Gain and Duty Cycle Correction Factor(if any) from the measured reading. The basic equation with a sample calculation is as follows:

$$FS = RA + AF + CL - AG$$

Where FS = Field Strength	CL = Cable Attenuation Factor (Cable Loss)
RA = Reading Amplitude	AG = Amplifier Gain
AF = Antenna Factor	

$$Transd=AF +CL-AG$$

**RADIATION LIMIT**

For intentional device, according to § 15.209(a), the general requirement of field strength of radiated emission from intentional radiators at a distance of 3 meters shall not exceed the following table. According to § 15.247(d), in any 100kHz bandwidth outside the frequency band in which the EUT is operating, the radio frequency power that is produced by the intentional radiator shall be at least 20dB below that in the100kHz bandwidth within the band that contains the highest level of desired power.

The pre-test have done for the EUT in three axes and found the worst emission at position shown in test setup photos.

Frequency (MHz)	Distance (Meters)	Radiated (dBµV/m)	Radiated (µV/m)
0.009-0.49	3	20log(2400/F(KHz))+40log(300/3)	2400/F(KHz)
0.49-1.705	3	20log(24000/F(KHz))+ 40log(30/3)	24000/F(KHz)
1.705-30	3	20log(30)+ 40log(30/3)	30
30-88	3	40.0	100
88-216	3	43.5	150
216-960	3	46.0	200
Above 960	3	54.0	500

**TEST RESULTS**

Remark:

1. This test was performed with EUT in X, Y, Z position and the worse case was found when EUT in X position.
2. All three channels (lowest/middle/highest) of each mode were measured below 1GHz and recorded worst case at 802.11b low channel.
3. Radiated emission test from 9 KHz to 10th harmonic of fundamental was verified, and no emission found except system noise floor in 9 KHz to 30MHz and not recorded in this report.
4. Remark: Result=Reading value+Factor

For 30MHz-1GHz

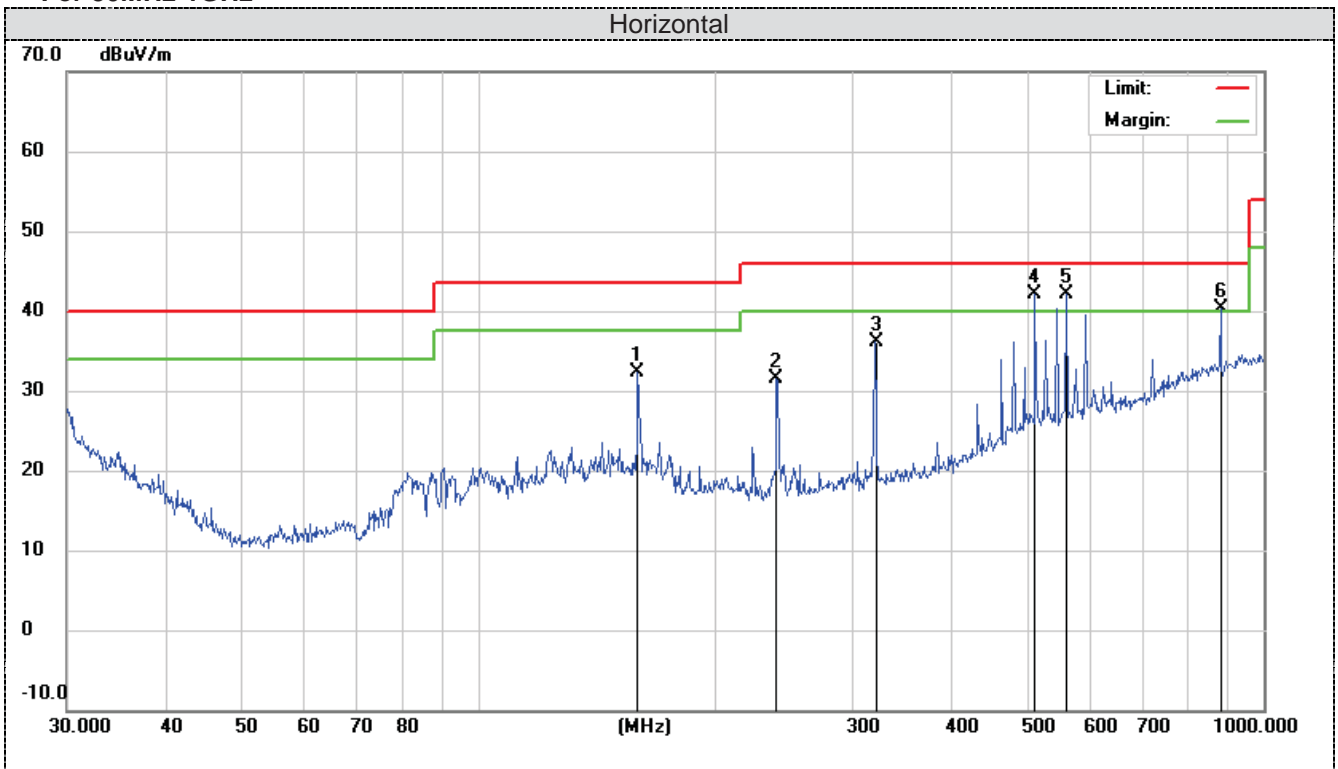

No.	Mk.	Freq. MHz	Reading Level dBuV	Correct Factor dB	Measure- ment dBuV/m	Limit dBuV/m	Over dB	Detector	Antenna Height cm	Table Degree degree	Comment
1		159.7844	15.00	17.31	32.31	43.50	-11.19	QP	200	75	
2		239.9873	17.50	14.08	31.58	46.00	-14.42	QP	200	130	
3		319.9370	20.17	15.88	36.05	46.00	-9.95	QP	200	230	
4	!	511.8352	19.21	22.83	42.04	46.00	-3.96	QP	200	280	
5	*	560.6928	18.70	23.37	42.07	46.00	-3.93	QP	200	310	
6	!	881.4067	11.46	28.80	40.26	46.00	-5.74	QP	200	330	

\*:Maximum data    x:Over limit    !:over margin



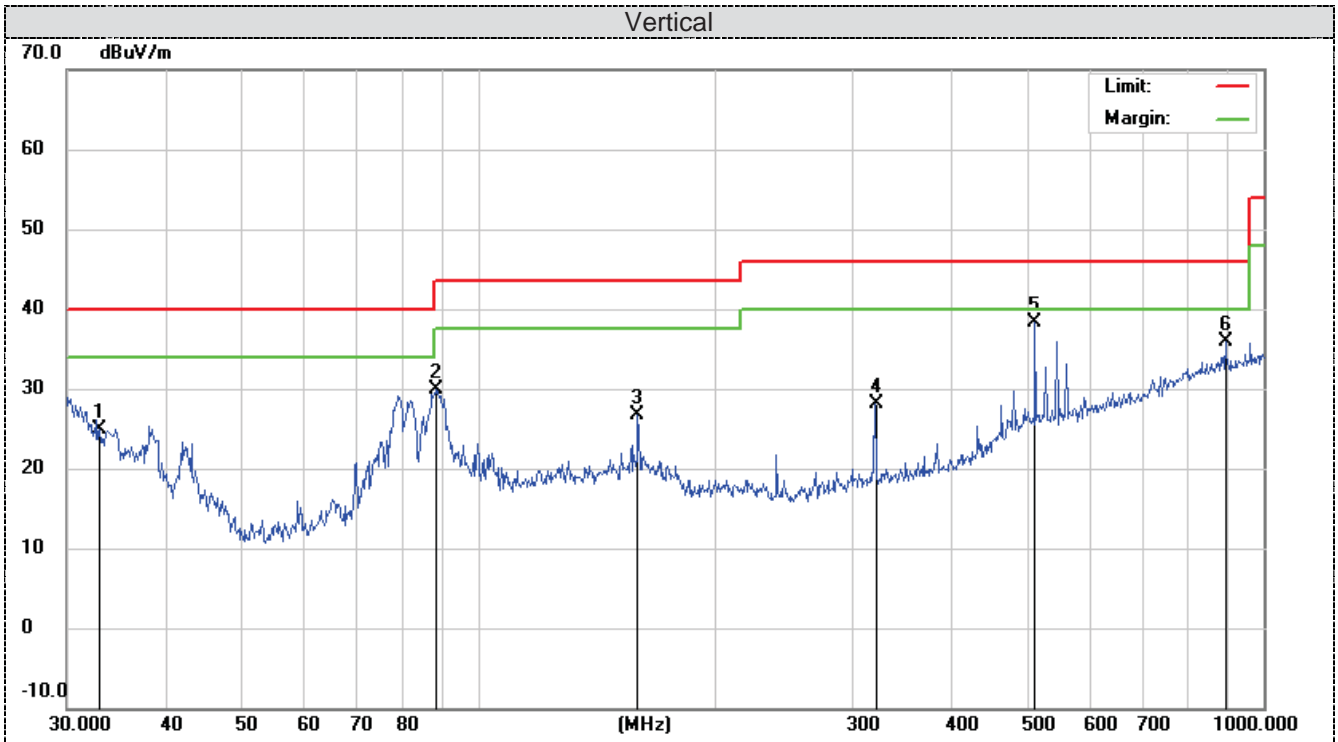

No.	Mk.	Freq. MHz	Reading Level dBuV	Correct Factor dB	Measure- ment dBuV/m	Limit dBuV/m	Over dB	Antenna Height cm	Table Degree	Comment
1		32.9791	6.05	18.87	24.92	40.00	-15.08	QP	100	45
2		88.6524	20.00	9.93	29.93	43.50	-13.57	QP	100	70
3		159.7844	9.16	17.51	26.67	43.50	-16.83	QP	100	90
4		319.9370	12.24	15.88	28.12	46.00	-17.88	QP	100	120
5	*	511.8352	15.55	22.83	38.38	46.00	-7.62	QP	100	150
6		893.8567	7.02	28.93	35.95	46.00	-10.05	QP	100	170

\*:Maximum data    x:Over limit    !:over margin

**For 1GHz to 25GHz**

Note: 802.11b/802.11g/802.11n (H20) all have been tested, only worse case 802.11b mode is reported

Polar (H/V)	Frequency	Meter Reading	Antenna Factor	Cable loss	Preamp factor	Emission Level	Limits	Margin	Detector Type
	(MHz)	(dBuV)	(dB)	(dB)	(dB)	(dBuV/m)	(dBuV/m)	(dB)	
<b>802.11b-2412MHz</b>									
V	4824	55.84	30.28	7.01	36.5	56.63	74	17.37	PK
V	4824	43.9	30.28	7.01	36.5	44.69	54	9.31	AV
H	4824	54.54	30.28	7.01	36.5	55.33	74	18.67	PK
H	4824	43.72	30.28	7.01	36.5	44.51	54	9.49	AV
V	7236	41.58	36.59	8.91	35.3	51.78	74	22.22	PK
V	7236	31.01	36.59	8.91	35.3	41.21	54	12.79	AV
H	7236	40.75	36.59	8.91	35.3	50.95	74	23.05	PK
H	7236	31.67	36.59	8.91	35.3	41.87	54	12.13	AV
<b>802.11b -2437MHz</b>									
V	4874	56.41	30.36	7.62	36.5	57.89	74	16.11	PK
V	4874	42.55	30.36	7.62	36.5	44.03	54	9.97	AV
H	4874	54.04	30.36	7.62	36.5	55.52	74	18.48	PK
H	4874	41.29	30.36	7.62	36.5	42.77	54	11.23	AV
V	7311	42.84	36.61	8.84	35.3	52.99	74	21.01	PK
V	7311	30.37	36.61	8.84	35.3	40.52	54	13.48	AV
H	7311	40.63	36.61	8.84	35.3	50.78	74	23.22	PK
H	7311	29.6	36.61	8.84	35.3	39.75	54	14.25	AV
<b>802.11b -2462MHz</b>									
V	4924	54.49	30.43	7.94	36.2	56.66	74	17.34	PK
V	4924	41.29	30.43	7.94	36.2	43.46	54	10.54	AV
H	4924	57.77	30.43	7.94	36.2	59.94	74	14.06	PK
H	4924	41.92	30.43	7.94	36.2	44.09	54	9.91	AV
V	7386	42.6	36.78	8.45	35.3	52.53	74	21.47	PK
V	7386	31.98	36.78	8.45	35.3	41.91	54	12.09	AV
H	7386	42.71	36.78	8.45	35.3	52.64	74	21.36	PK
H	7386	29.56	36.78	8.45	35.3	39.49	54	14.51	AV

**Note:**

- 1) Emission level (dBuV/m) = Meter Reading+ antenna Factor+ cable loss- preamp factor.
- 2) Margin value = Limits-Emission level.
- 3) -- Mean the PK detector measured value is below average limit.
- 4) The other emission levels were very low against the limit.
- 5) RBW1MHz VBW3MHz Peak detector is for PK value; RBW 1MHz VBW10Hz Peak detector is for AV value.

**Results of Band Edges Test (Radiated)**

Polar (H/V)	Frequency	Meter Reading	Antenna Factor	Cable loss	Preamp factor	Emission Level	Limits	Margin	Detector Type
	(MHz)	(dBuV)	(dB)	(dB)	(dB)	(dBuV/m)	(dBuV/m)	(dB)	
<b>802.11b -2412MHz</b>									
V	2390	59.23	27.49	3.32	36.22	53.82	74	20.18	PK
V	2390	45.76	27.49	3.32	36.22	40.35	54	13.65	AV
H	2390	58.05	27.49	3.32	36.22	52.64	74	21.36	PK
H	2390	46.96	27.49	3.32	36.22	41.55	54	12.45	AV
V	2400	59.56	27.55	3.41	36.22	54.3	74	19.7	PK
V	2400	45.63	27.55	3.41	36.22	40.37	54	13.63	AV
H	2400	59.05	27.55	3.41	36.22	53.79	74	20.21	PK
H	2400	44.68	27.55	3.41	36.22	39.42	54	14.58	AV
<b>802.11b -2462MHz</b>									
V	2483.5	58.53	27.45	3.38	36.34	53.02	74	20.98	PK
V	2483.5	47.23	27.45	3.38	36.34	41.72	54	12.28	AV
H	2483.5	59.91	27.45	3.38	36.34	54.4	74	19.6	PK
H	2483.5	44.47	27.45	3.38	36.34	38.96	54	15.04	AV
V	2500	57.26	27.41	3.47	36.35	51.79	74	22.21	PK
V	2500	46.17	27.41	3.47	36.35	40.7	54	13.3	AV
H	2500	59.65	27.41	3.47	36.35	54.18	74	19.82	PK
H	2500	43.48	27.41	3.47	36.35	38.01	54	15.99	AV

Polar (H/V)	Frequency	Meter Reading	Antenna Factor	Cable loss	Preamp factor	Emission Level	Limits	Margin	Detector Type
	(MHz)	(dBuV)	(dB)	(dB)	(dB)	(dBuV/m)	(dBuV/m)	(dB)	
<b>802.11g -2412MHz</b>									
V	2390	55.35	27.49	3.32	36.22	49.94	74	24.06	PK
V	2390	46.24	27.49	3.32	36.22	40.83	54	13.17	AV
H	2390	55.88	27.49	3.32	36.22	50.47	74	23.53	PK
H	2390	44.81	27.49	3.32	36.22	39.4	54	14.6	AV
V	2400	57.43	27.55	3.41	36.22	52.17	74	21.83	PK
V	2400	46.64	27.55	3.41	36.22	41.38	54	12.62	AV
H	2400	57.14	27.55	3.41	36.22	51.88	74	22.12	PK
H	2400	45.19	27.55	3.41	36.22	39.93	54	14.07	AV
<b>802.11g -2462MHz</b>									
V	2483.5	57.75	27.45	3.38	36.34	52.24	74	21.76	PK
V	2483.5	47.04	27.45	3.38	36.34	41.53	54	12.47	AV
H	2483.5	55.61	27.45	3.38	36.34	50.1	74	23.9	PK
H	2483.5	45.2	27.45	3.38	36.34	39.69	54	14.31	AV
V	2500	55.66	27.41	3.47	36.35	50.19	74	23.81	PK
V	2500	46.09	27.41	3.47	36.35	40.62	54	13.38	AV
H	2500	58.53	27.41	3.47	36.35	53.06	74	20.94	PK
H	2500	46.18	27.41	3.47	36.35	40.71	54	13.29	AV

Polar (H/V)	Frequency	Meter Reading	Antenna Factor	Cable loss	Preamp factor	Emission Level	Limits	Margin	Detector Type
	(MHz)	(dBuV)	(dB)	(dB)	(dB)	(dBuV/m)	(dBuV/m)	(dB)	
<b>802.11n -2412MHz</b>									
V	2390	57.03	27.49	3.32	36.22	51.62	74	22.38	PK
V	2390	44.74	27.49	3.32	36.22	39.33	54	14.67	AV
H	2390	57.24	27.49	3.32	36.22	51.83	74	22.17	PK
H	2390	44.33	27.49	3.32	36.22	38.92	54	15.08	AV
V	2400	58.34	27.55	3.41	36.22	53.08	74	20.92	PK
V	2400	44.84	27.55	3.41	36.22	39.58	54	14.42	AV
H	2400	59.74	27.55	3.41	36.22	54.48	74	19.52	PK
H	2400	47.68	27.55	3.41	36.22	42.42	54	11.58	AV
<b>802.11n -2462MHz</b>									
V	2483.5	57.9	27.45	3.38	36.34	52.39	74	21.61	PK
V	2483.5	43.23	27.45	3.38	36.34	37.72	54	16.28	AV
H	2483.5	56.55	27.45	3.38	36.34	51.04	74	22.96	PK
H	2483.5	47.43	27.45	3.38	36.34	41.92	54	12.08	AV
V	2500	56.89	27.41	3.47	36.35	51.42	74	22.58	PK
V	2500	44.95	27.41	3.47	36.35	39.48	54	14.52	AV
H	2500	57.61	27.41	3.47	36.35	52.14	74	21.86	PK
H	2500	45.83	27.41	3.47	36.35	40.36	54	13.64	AV

## Note:

- 1) Emission level (dBuV/m) = Meter Reading+ antenna Factor+ cable loss- preamp factor.
- 2) Margin value = Limits-Emission level.
- 3) -- Mean the PK detector measured value is below average limit.
- 4) The other emission levels were very low against the limit.
- 5) RBW1MHz VBW3MHz Peak detector is for PK value; RBW 1MHz VBW10Hz Peak detector is for AV value.

### 5.3 Maximum Conducted Output Power

#### Limit

The Maximum Peak Output Power Measurement is 30dBm.

#### Test Procedure

Remove the antenna from the EUT and then connect a low loss RF cable from the antenna port to the power sensor.

#### Test Configuration

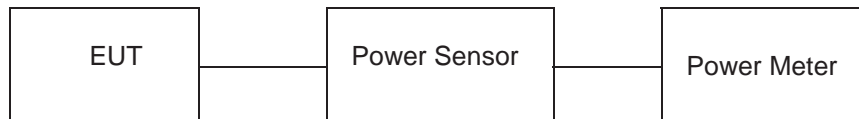

#### Test Results

Type	Channel	Output power PK (dBm)	Limit (dBm)	Result
802.11b	01	8.767	30.00	Pass
	06	10.596		
	11	8.756		
802.11g	01	9.441	30.00	Pass
	06	11.089		
	11	10.277		
802.11n(HT20)	01	9.612	30.00	Pass
	06	10.561		
	11	9.609		

Note:

- 1) Measured output power at difference data rate for each mode and recorded worst case for each mode.
- 2) Test results including cable loss.
- 3) Worst case data at 1Mbps at IEEE 802.11b; 6Mbps at IEEE 802.11g; 6.5Mbps at IEEE 802.11n HT20;

### 5.4 Power Spectral Density

**Limit**

For digitally modulated systems, the power spectral density conducted from the intentional radiator to the antenna shall not be greater than 8 dBm in any 3 kHz band during any time interval of continuous transmission.

**Test Procedure**

1. Use this procedure when the maximum peak conducted output power in the fundamental emission is used to demonstrate compliance.
2. Set the RBW  $\geq$  3 kHz.
3. Set the VBW  $\geq$  3 $\times$  RBW.
4. Set the span to 1.5 times the DTS channel bandwidth.
5. Detector = peak.
6. Sweep time = auto couple.
7. Trace mode = max hold.
8. Allow trace to fully stabilize.
9. Use the peak marker function to determine the maximum power level.
10. If measured value exceeds limit, reduce RBW (no less than 3 kHz) and repeat.
11. The resulting peak PSD level must be 8dBm.

**Test Configuration**

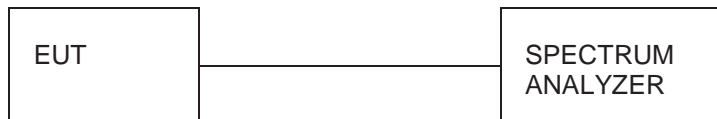

**Test Results**

Type	Channel	Power Spectral Density (dBm/3KHz)	Limit (dBm/3KHz)	Result
802.11b	01	-3.598	8.00	Pass
	06	-2.508		
	11	-4.913		
802.11g	01	-3.519	8.00	Pass
	06	-2.861		
	11	-3.567		
802.11n(HT20)	01	-3.071	8.00	Pass
	06	-2.220		
	11	-3.316		

Note:

- 1) Measured peak power spectrum density at difference data rate for each mode and recorded worst case for each mode.
- 2) Test results including cable loss;
- 3) Worst case data at 1Mbps at IEEE 802.11b; 6Mbps at IEEE 802.11g; 6.5Mbps at IEEE 802.11n HT20;

Please refer to following plots;

802.11b



802.11g

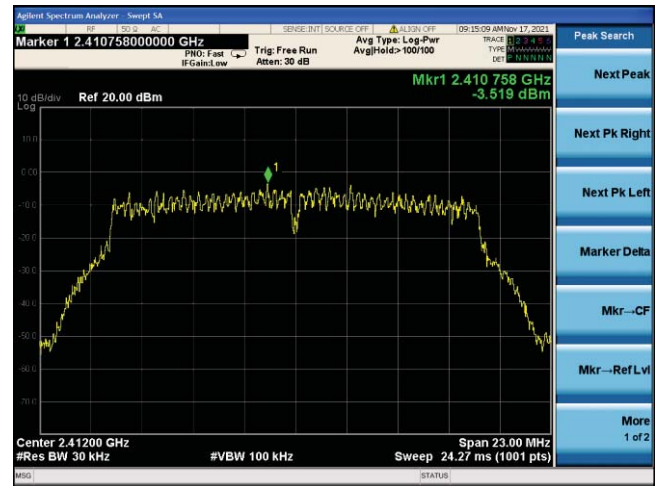

CH01

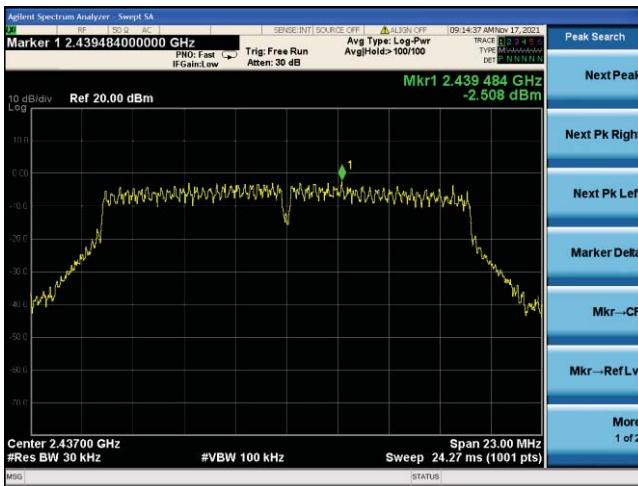

CH01



CH06

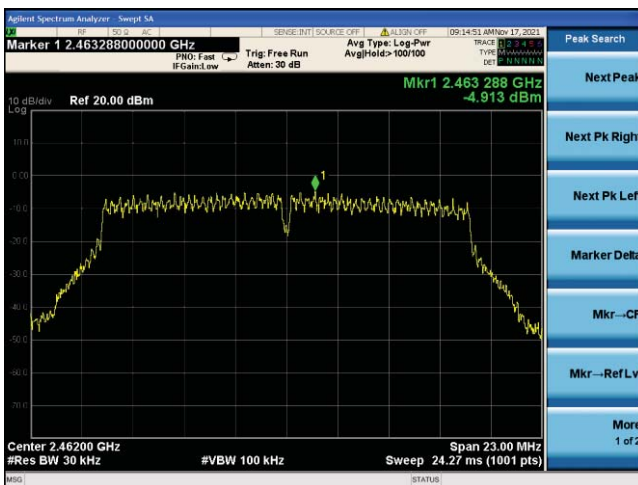

CH06

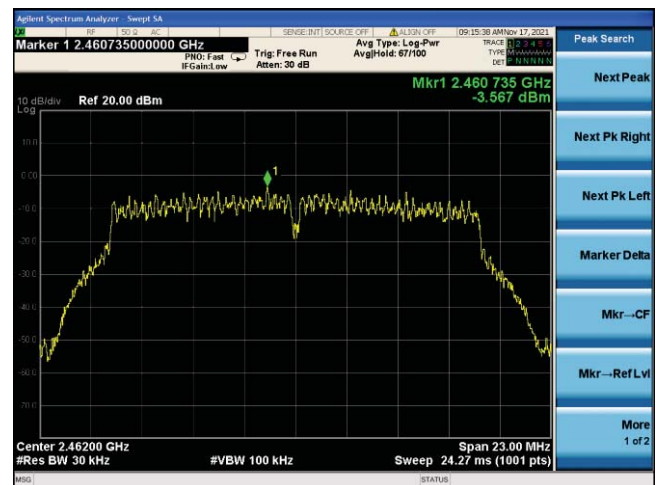

CH11

CH11

802.11n(HT20)



CH01



CH06

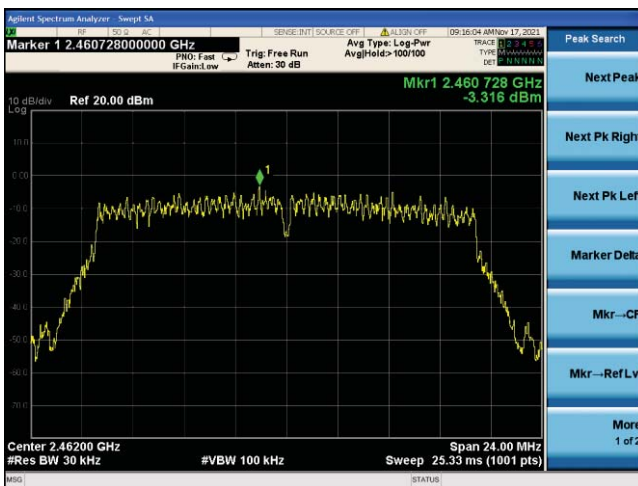

CH11



## 5.5 6dB Bandwidth

### Limit

For digital modulation systems, the minimum 6 dB bandwidth shall be at least 500 kHz

### Test Procedure

The transmitter output was connected to the spectrum analyzer through an attenuator. The bandwidth of the fundamental frequency was measured by spectrum analyzer with 100 KHz RBW and 300 KHz VBW. The 6dB bandwidth is defined as the total spectrum the power of which is higher than peak power minus 6dB.

### Test Configuration

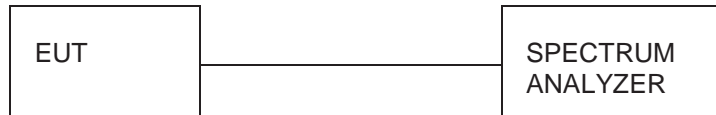

### Test Results

Type	Channel	6dB Bandwidth (MHz)	Limit (KHz)	Result
802.11b	01	15.67	≥500	Pass
	06	15.70		
	11	15.37		
802.11g	01	16.04	≥500	Pass
	06	15.53		
	11	15.75		
802.11n(HT20)	01	16.03	≥500	Pass
	06	15.62		
	11	16.27		

Note:

- 1) Measured peak power spectrum density at difference data rate for each mode and recorded worst case for each mode.
- 2) Test results including cable loss;
- 3) Worst case data at 1Mbps at IEEE 802.11b; 6Mbps at IEEE 802.11g; 6.5Mbps at IEEE 802.11n HT20;

Please refer to following plots;

802.11b

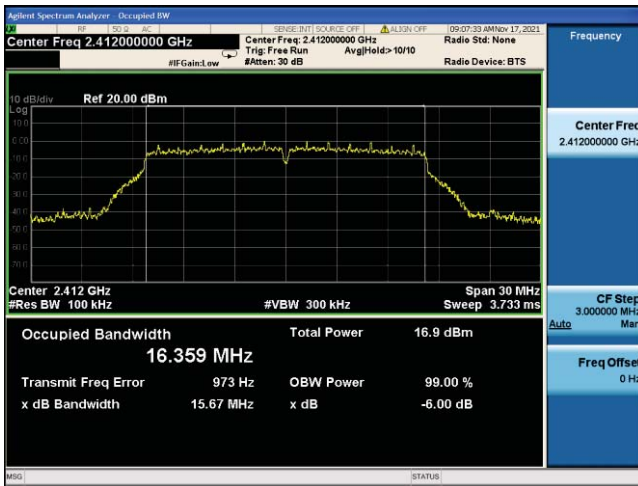

802.11g

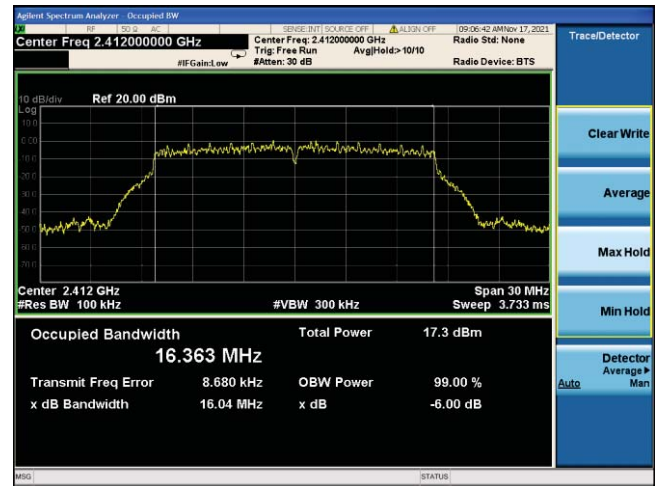

CH01

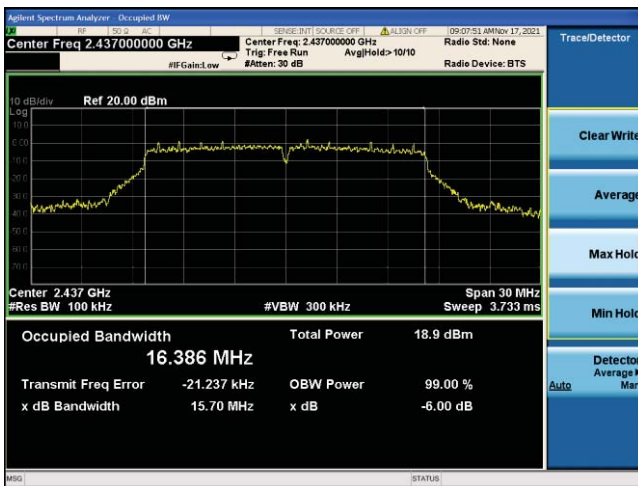

CH01

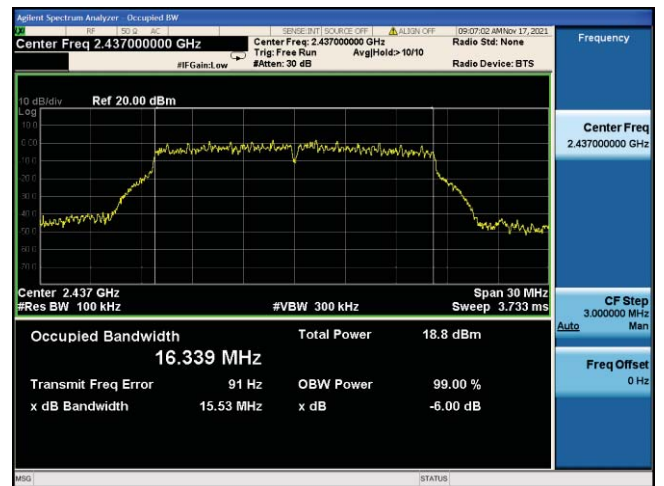

CH06

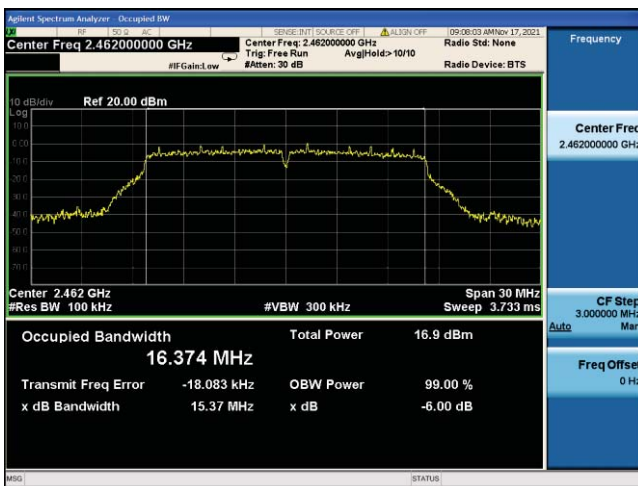

CH06

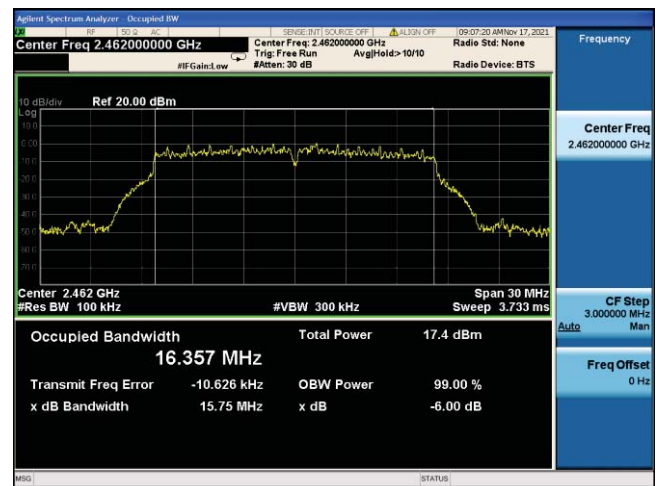

CH11



CH11



802.11n(HT20)

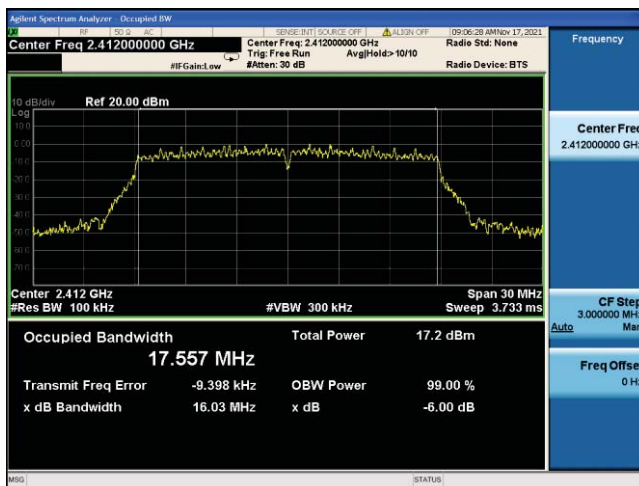

CH01

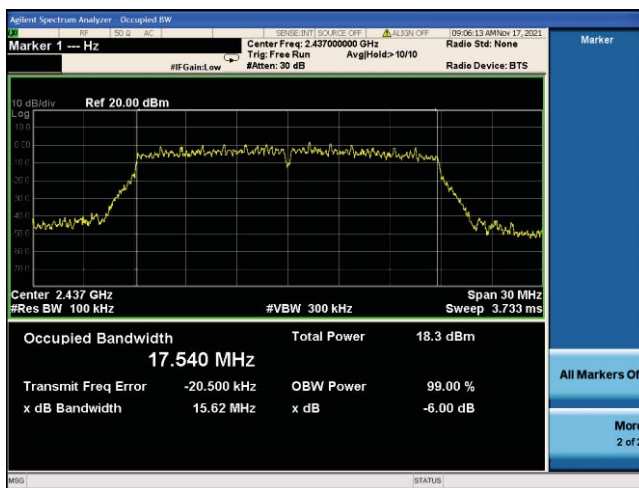

CH06

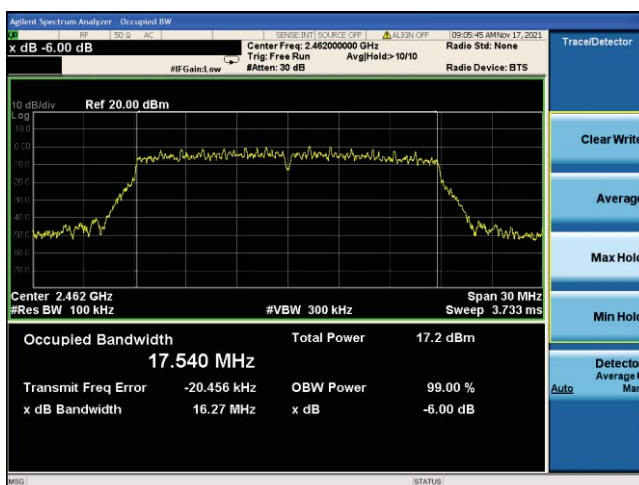

CH11

## 5.6 Out-of-band Emissions

### Limit

In any 100 kHz bandwidth outside the frequency band in which the spread spectrum or digitally modulated intentional radiator is operating, the radio frequency power that is produced by the intentional radiator shall be at least 20 dB below that in the 100 kHz bandwidth within the band that contains the highest level of the desired power, based on either an RF conducted or a radiated measurement, provided the transmitter demonstrates compliance with the peak conducted power limits. If the transmitter complies with the conducted power limits based on the use of RMS averaging over a time interval, as permitted under paragraph (b)(3) of this section, the attenuation required under this paragraph shall be 30 dB instead of 20 dB. Attenuation below the general limits specified in §15.209(a) is not required.

### Test Procedure

Connect the transmitter output to spectrum analyzer using a low loss RF cable, and set the spectrum analyzer to RBW=100 kHz, VBW= 300 kHz, peak detector , and max hold. Measurements utilizing these setting are made of the in-band reference level, bandedge and out-of-band emissions.

### Test Configuration



### Test Results

Remark: The measurement frequency range is from 30MHz to the 10th harmonic of the fundamental frequency. The lowest, middle and highest channels are tested to verify the spurious emissions and bandage measurement data. And record the worst data in the report.

Test plot as follows:

802.11b

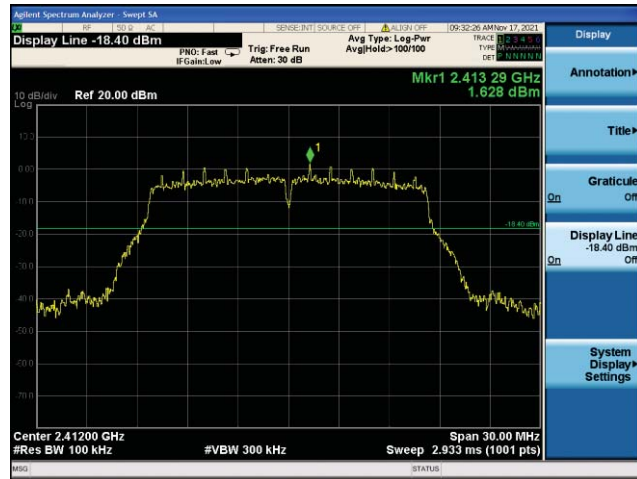

CH01

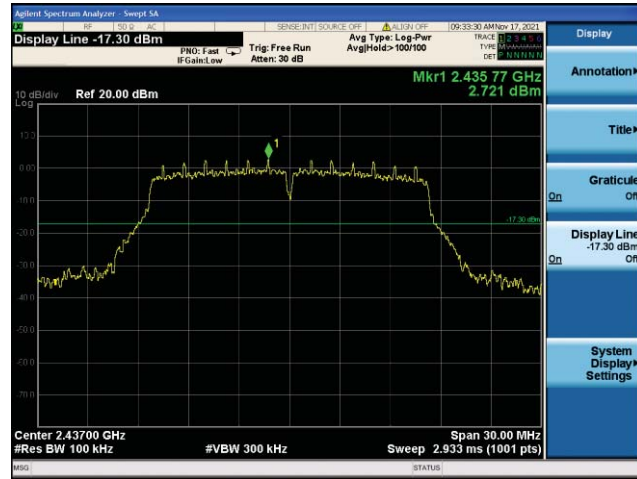

CH06



CH11

802.11g

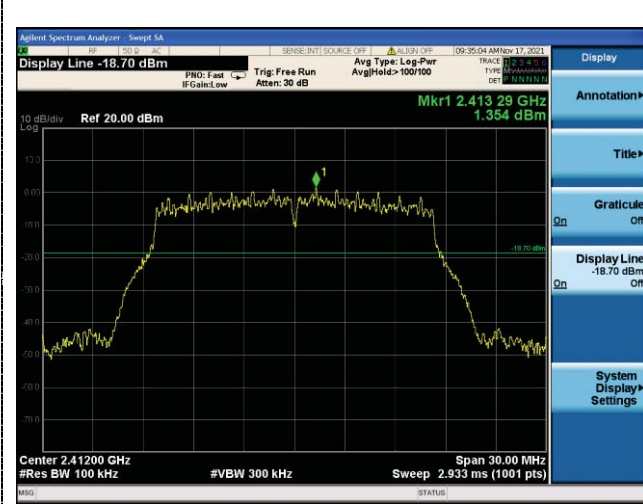

CH01

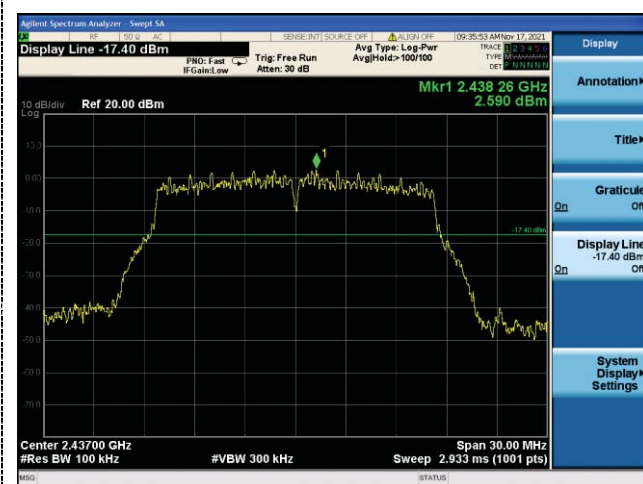

CH06



CH11

802.11n(HT20)

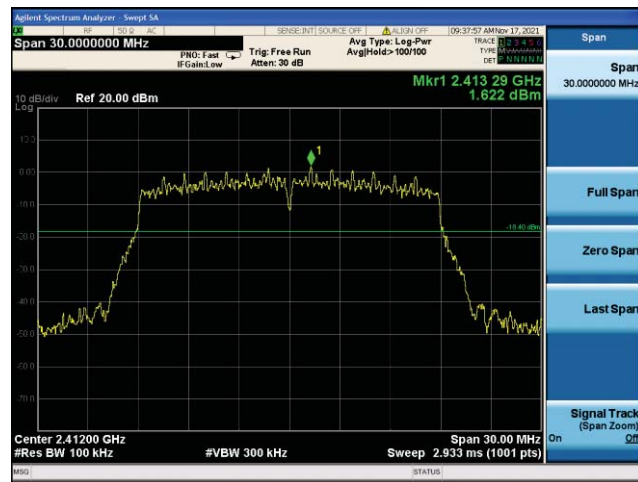

CH01

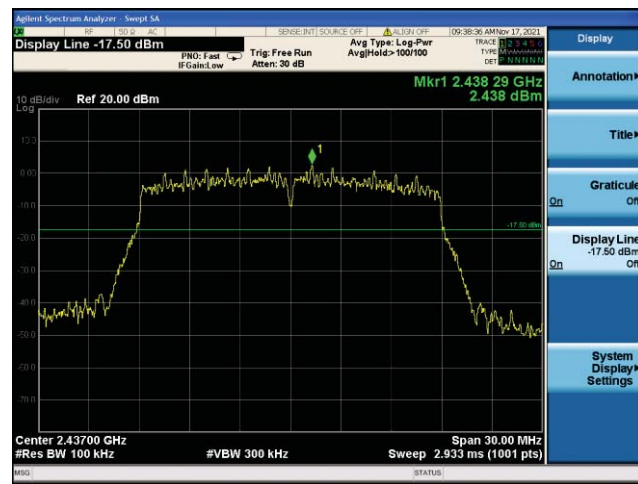

CH06

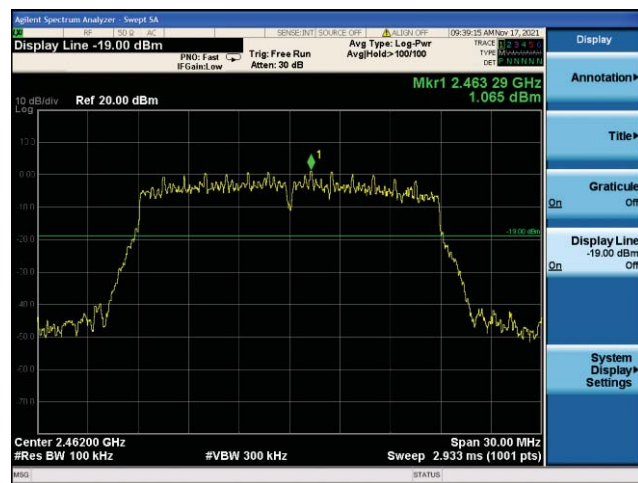

CH11

**Band-edge Measurements for RF Conducted Emissions:**

**802.11b**

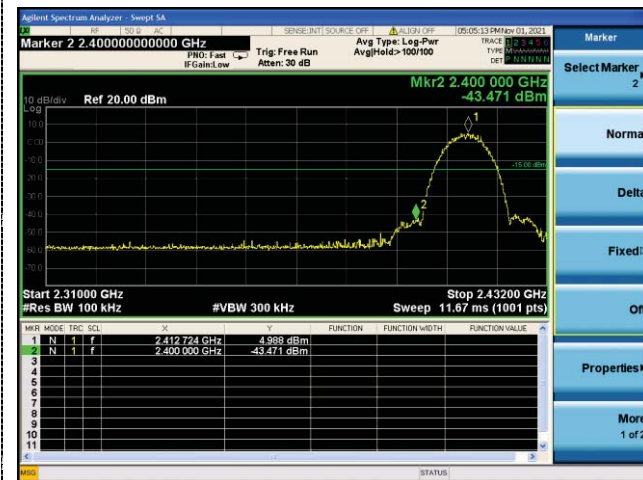

Left bandedge



Right bandedge

**802.11g**

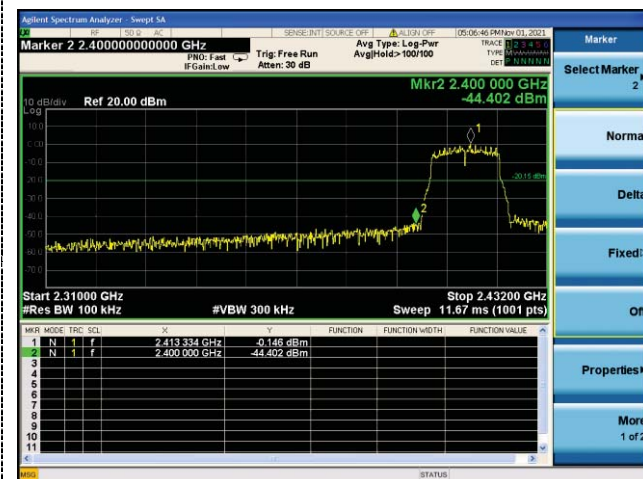

Left bandedge

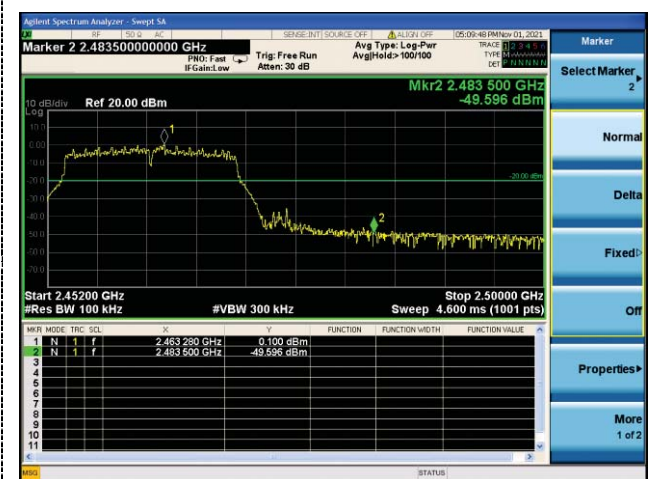

Right bandedge

**802.11n(HT20)**

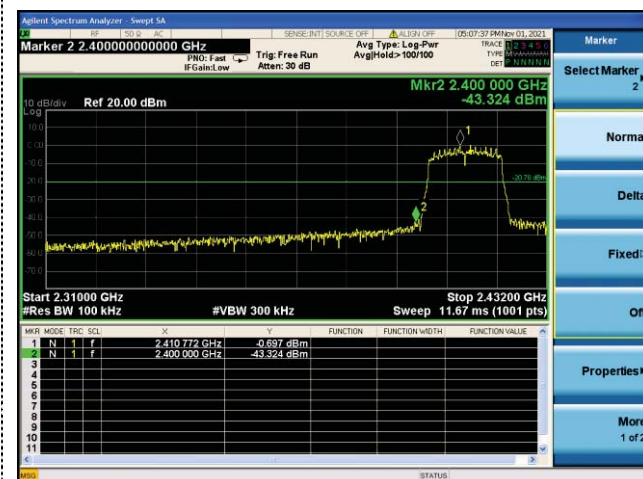

Left bandedge

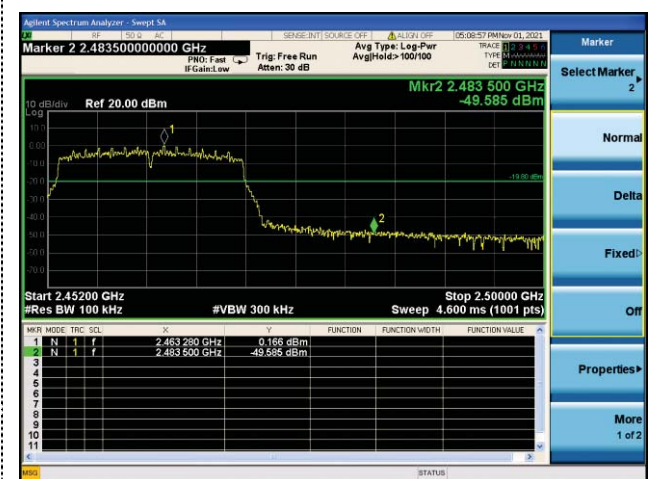

Right bandedge



## 5.7 Antenna Requirement

### Standard Applicable

**For intentional device, according to FCC 47 CFR Section 15.203:**

An intentional radiator shall be designed to ensure that no antenna other than that furnished by the responsible party shall be used with the device. The use of a permanently attached antenna or of an antenna that uses a unique coupling to the intentional radiator, the manufacturer may design the unit so that a broken antenna can be replaced by the user, but the use of a standard antenna jack or electrical connector is prohibited

**FCC CFR Title 47 Part 15 Subpart C Section 15.247(c) (1) (I):**

(i) Systems operating in the 2400-2483.5 MHz band that is used exclusively for fixed. Point-to-point operations may employ transmitting antennas with directional gain greater than 6dBi provided the maximum conducted output power of the intentional radiator is reduced by 1 dB for every 3 dB that the directional gain of the antenna exceeds 6dBi.

### Test Result:

The directional gains of antenna used for transmitting is 0 dBi, and the antenna is an internal antenna connect to PCB board and no consideration of replacement. Please see EUT photo for details.

Results: Compliance.

## 6 Test Setup Photos of the EUT

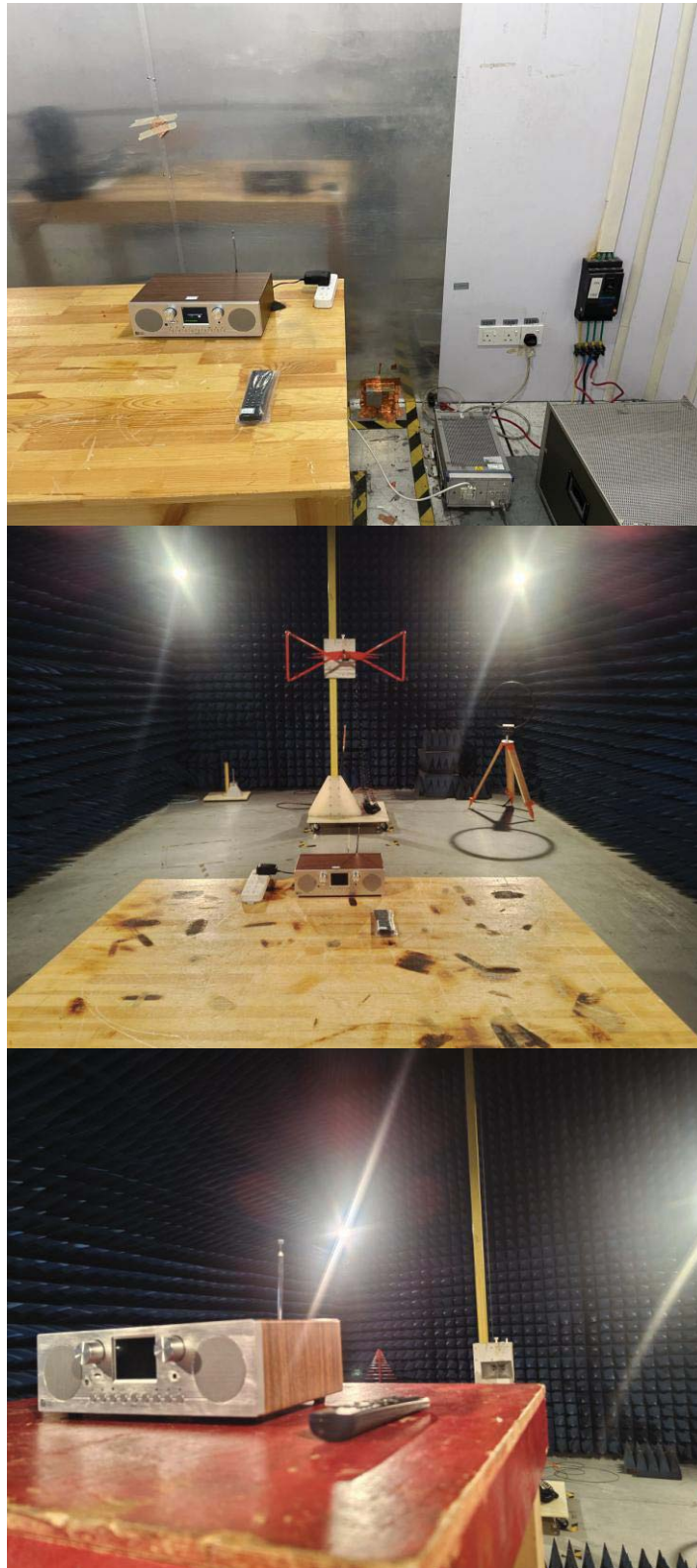

## **7 Photos of the EUT**

See related photo report.

**\*\*\*\*\* End of Report \*\*\*\*\***