FCC Test Report

Report No.: AGC00070151101FE03

FCC ID : 2ABCJAU04
APPLICATION PURPOSE : Original Equipment
PRODUCT DESIGNATION : Bluetooth Receiver
BRAND NAME : bluMe
MODEL NAME : AU04
CLIENT : Auris, Inc.
DATE OF ISSUE : Dec.15,2015
STANDARD(S) : FCC Part 15 Rules
TEST PROCEDURE(S)
REPORT VERSION : V1.0

Attestation of Global Compliance (Shenzhen) Co., Ltd



CAUTION:

This report shall not be reproduced except in full without the written permission of the test laboratory and shall not be quoted out of context.



Report Revise Record

Report Version	Revise Time	Issued Date	Valid Version	Notes
V1.0	/	Dec.15,2015	Valid	Original Report

TABLE OF CONTENTS

1. VERIFICATION OF CONFORMITY	4
2. GENERAL INFORMATION	5
2.1. PRODUCT DESCRIPTION.....	5
2.2. TABLE OF CARRIER FREQUENCYS.....	5
3. MEASUREMENT UNCERTAINTY.....	7
4. DESCRIPTION OF TEST MODES.....	7
5. SYSTEM TEST CONFIGURATION	8
5.1. CONFIGURATION OF EUT SYSTEM	8
5.2. EQUIPMENT USED IN EUT SYSTEM	8
5.3. SUMMARY OF TEST RESULTS	8
6. TEST FACILITY	9
7.ALL TEST EQUIPMENT LIST	9
8. RADIATED EMISSION	11
8.1TEST LIMIT.....	11
8.2. MEASUREMENT PROCEDURE	12
8.3. TEST SETUP.....	14
8.4. TEST RESULT	16
9. BAND EDGE EMISSION	42
9.1. MEASUREMENT PROCEDURE	42
9.2 TEST SETUP	42
9.3 RADIATED TEST RESULT	43
10. 20DB BANDWIDTH.....	51
10.1. MEASUREMENT PROCEDURE	51
10.2. TEST SET-UP	51
10.3. LIMITS AND MEASUREMENT RESULTS.....	51
11. FCC LINE CONDUCTED EMISSION TEST	60
11.1. LIMITS OF LINE CONDUCTED EMISSION TEST	60
11.2. BLOCK DIAGRAM OF LINE CONDUCTED EMISSION TEST.....	60
11.3. PRELIMINARY PROCEDURE OF LINE CONDUCTED EMISSION TEST	61
11.4. FINAL PROCEDURE OF LINE CONDUCTED EMISSION TEST.....	61
11.5. TEST RESULT OF LINE CONDUCTED EMISSION TEST.....	62
APPENDIX A: PHOTOGRAPHS OF TEST SETUP	66
APPENDIX B: PHOTOGRAPHS OF EUT	68

1. VERIFICATION OF CONFORMITY

Applicant	Auris, Inc.
Address	5001 Great America Parkway,Suite 290,Santa Clara,California,95054,United States
Manufacturer	AVLink Industrial Co., Ltd.
Address	7F., A1 Bldg., 1st Shuichanjingwan Industrial Area, Nanchang Village, Gushu, Bao'an District, Shenzhen, Guangdong, China
Product Designation	Bluetooth Receiver
Brand Name	bluMe
Test Model	AU04
Date of test	Nov.19,2015 to Nov.23,2015
Deviation	None
Condition of Test Sample	Normal
Report Template	AGCRT-US-BR/RF

We hereby certify that:

The above equipment was tested by Dongguan Precise Testing Service Co., Ltd. The test data, data evaluation, test procedures, and equipment configurations shown in this report were made in accordance with the procedures given in ANSI C63.4 (2009) and the energy emitted by the sample EUT tested as described in this report is in compliance with radiated emission limits of FCC Rules Part 15.249.

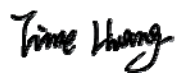
Tested By 
Time Huang(Huang Nanhui) Dec.15,2015

Reviewed By 
Forrest Lei(Lei Yonggang) Dec.15,2015

Approved By 
Solger Zhang(Zhang Hongyi)
Authorized Officer Dec.15,2015

2. GENERAL INFORMATION

2.1. PRODUCT DESCRIPTION

A major technical description of EUT is described as following

Operation Frequency	2.402 GHz to 2.480GHz
RF Output Power	2.62dBm(Max)
Bluetooth Version	V4.1
Modulation	GFSK, $\pi/4$ -DQPSK, 8DPSK
Number of channels	79 for BR/EDR, 40 for BLE
Hardware Version	V3.1
Software Version	V1
Antenna Designation	Fixed Antenna (Met 15.203 Antenna requirement)
Antenna Gain	0dBi
Power Supply	DC 5V

Note: The USB port only used for power supply and can't be used to transfer data with PC.

2.2. TABLE OF CARRIER FREQUENCIES

BR/EDR channel List

Frequency Band	Channel Number	Frequency
2400~2483.5MHZ	0	2402MHZ
	1	2403MHZ
	:	:
	38	2440 MHZ
	39	2441 MHZ
	40	2442 MHZ
	:	:
	77	2479 MHZ
	78	2480 MHZ

BLE Channel List

Frequency Band	Channel Number	Frequency
2400~2483.5MHZ	0	2402MHZ
	1	2404MHZ
	:	:
	38	2478 MHZ
	39	2480 MHZ

3. MEASUREMENT UNCERTAINTY

The reported uncertainty of measurement $y \pm U$, where expanded uncertainty U is based on a standard uncertainty multiplied by a coverage factor of $k=2$, providing a level of confidence of approximately 95 %.

No.	Item	Uncertainty
1	Conducted Emission Test	$\pm 3.18\text{dB}$
2	All emissions, radiated	$\pm 3.91\text{dB}$
3	Temperature	$\pm 0.5^\circ\text{C}$
4	Humidity	$\pm 2\%$

4. DESCRIPTION OF TEST MODES

NO.	TEST MODE DESCRIPTION
1	Low channel GFSK
2	Middle channel GFSK
3	High channel GFSK
4	Low channel $\pi/4$ -DQPSK
5	Middle channel $\pi/4$ -DQPSK
6	High channel $\pi/4$ -DQPSK
7	Low channel 8DPSK
8	Middle channel 8DPSK
9	High channel 8DPSK
10	BT Link

Note:

1. Only the result of the worst case was recorded in the report, if no other cases.
2. For Radiated Emission, 3axis were chosen for testing for each applicable mode.

5. SYSTEM TEST CONFIGURATION

5.1. CONFIGURATION OF EUT SYSTEM

Configure 1: (Normal hopping)

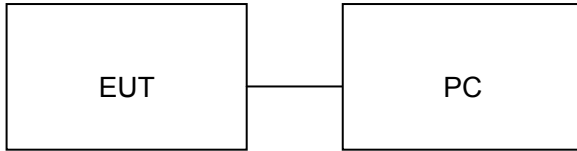

Configure 2: (Control continuous TX)

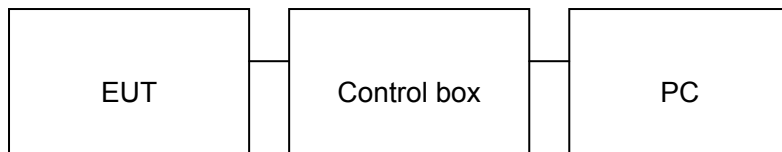

5.2. EQUIPMENT USED IN EUT SYSTEM

Item	Equipment	Model No.	ID or Specification	Remark
1	Bluetooth Receiver	bluMe	AU04	EUT
2	PC	SONY	E1412AYCW	A.E
3	Control box	N/A	N/A	A.E
4	Earphone	S1	1.2m, unshielded	A.E
5	USB Cable	N/A	0.6m, unshielded	A.E
6	Temporary Antenna Connector	T10	N/A	A.E

5.3. SUMMARY OF TEST RESULTS

FCC RULES	DESCRIPTION OF TEST	RESULT
§15.249	Radiated Emission	Compliant
§15.249	Band Edges	Compliant
§15.207	Conduction Emission	Compliant
N/A	BANDWIDTH	Compliant

6. TEST FACILITY

Site	Dongguan Precise Testing Service Co., Ltd.
Location	Building D,Baoding Technology Park,Guangming Road2,Dongcheng District, Dongguan, Guangdong, China,
FCC Registration No.	371540
Description	The test site is constructed and calibrated to meet the FCC requirements in documents ANSI C63.4:2009.

7. ALL TEST EQUIPMENT LIST

FOR RADIATED EMISSION TEST (BELOW 1GHZ)

Radiated Emission Test Site					
Name of Equipment	Manufacturer	Model Number	Serial Number	Last Calibration	Due Calibration
EMI Test Receiver	Rohde & Schwarz	ESCI	101417	July 4, 2015	July 3, 2016
Trilog Broadband Antenna (25M-1GHz)	SCHWARZBECK	VULB9160	9160-3355	July 4, 2015	July 3, 2016
Signal Amplifier	SCHWARZBECK	BBV 9475	9745-0013	July 4, 2015	July 3, 2016
RF Cable	SCHWARZBECK	AK9515E	96221	July 4, 2015	July 3, 2016
3m Anechoic Chamber	CHENGYU	966	PTS-001	June 6, 2015	June 5, 2016
MULTI-DEVICE Positioning Controller	Max-Full	MF-7802	MF780208339	N/A	N/A
Active loop antenna (9K-30MHz)	Schwarzbeck	FMZB1519	1519-038	June 6, 2015	June 5, 2016
Spectrum analyzer	Agilent	E4407B	MY46185649	June 6, 2015	June 5, 2016
Radiation Cable 1	MXT	RS1	R005	June 6, 2015	June 5, 2016
Radiation Cable 2	MXT	RS1	R006	June 6, 2015	June 5, 2016

FOR RADIATED EMISSION TEST (1GHZ ABOVE)

Radiated Emission Test Site					
Name of Equipment	Manufacturer	Model Number	Serial Number	Last Calibration	Due Calibration
EMI Test Receiver	Rohde & Schwarz	ESCI	101417	July 4, 2015	July 3, 2016
Horn Antenna (1G-18GHz)	SCHWARZBECK	BBHA9120D	9120D-1246	July 11, 2015	July 10, 2016
Spectrum Analyzer	Agilent	E4411B	MY4511453	July 4, 2015	July 3, 2016
Signal Amplifier	SCHWARZBECK	BBV 9718	9718-269	July 7, 2015	July 6, 2016
RF Cable	SCHWARZBECK	AK9515H	96220	July 8, 2015	July 7, 2016
3m Anechoic Chamber	CHENGYU	966	PTS-001	June 6, 2015	June 5, 2016
MULTI-DEVICE Positioning Controller	Max-Full	MF-7802	MF780208339	N/A	N/A
Horn Ant (18G-40GHz)	Schwarzbeck	BBHA 9170	9170-181	June 6, 2015	June 5, 2016
Radiation Cable 1	MXT	RS1	R005	June 6, 2015	June 5, 2016
Radiation Cable 2	MXT	RS1	R006	June 6, 2015	June 5, 2016

Conducted Emission Test Site					
Name of Equipment	Manufacturer	Model Number	Serial Number	Last Calibration	Due Calibration
EMI Test Receiver	- Rohde & Schwarz	ESCI	101417	July 4, 2015	July 3, 2016
Artificial Mains Network	Narda	L2-16B	000WX31025	July 8, 2015	July 7, 2016
Artificial Mains Network (AUX)	Narda	L2-16B	000WX31026	July 8, 2015	July 7, 2016
RF Cable	SCHWARZBECK	AK9515E	96222	July 4, 2015	July 3, 2016
Shielded Room	CHENGYU	843	PTS-002	June 6,2015	June 5,2016
Conduction Cable	MXT	SE1	S003	June 6,2015	June 5,2016

8. RADIATED EMISSION

8.1 TEST LIMIT

Standard FCC15.249

Fundamental Frequency	Field Strength of Fundamental (millivolts/meter)	Field Strength of Harmonics (microvolts/meter)
900-928MHz	50	500
2400-2483.5MHz	50	500
5725-5875MHz	50	500
24.0-24.25GHz	250	2500

Standard FCC 15.209

Frequency (MHz)	Distance Meters	Field Strengths Limit	
		μ V/m	dB(μ V)/m
0.009 ~ 0.490	300	2400/F(kHz)	---
0.490 ~ 1.705	30	24000/F(kHz)	---
1.705 ~ 30	30	30	---
30 ~ 88	3	100	40.0
88 ~ 216	3	150	43.5
216 ~ 960	3	200	46.0
960 ~ 1000	3	500	54.0
Above 1000	3	Other:74.0 dB(μ V)/m (Peak) 54.0 dB(μ V)/m (Average)	

Remark: (1) Emission level dB μ V = 20 log Emission level μ V/m
(2) The smaller limit shall apply at the cross point between two frequency bands.
(3) Distance is the distance in meters between the measuring instrument, antenna and the closest point of any part of the device or system.

8.2. MEASUREMENT PROCEDURE

1. Configure the EUT according to ANSI C63.4. The EUT was placed on the top of the turntable 0.8 meter above ground. The phase center of the receiving antenna mounted on the top of a height-variable antenna tower was placed 3 meters far away from the turntable.
2. Power on the EUT and all the supporting units. The turntable was rotated by 360 degrees to determine the position of the highest radiation.
3. The height of the broadband receiving antenna was varied between one meter and four meters above ground to find the maximum emissions field strength of both horizontal and vertical polarization.
4. For each suspected emissions, the antenna tower was scan (from 1 M to 4 M) and then the turntable was rotated (from 0 degree to 360 degrees) to find the maximum reading.
5. Set the test-receiver system to Peak or CISPR quasi-peak Detect Function with specified bandwidth under Maximum Hold Mode.
6. For emissions above 1GHz, use 1.5MHz VBW and RBW for peak reading. Then 1.5MHz RBW and 10Hz VBW for average reading in spectrum analyzer.
7. When the radiated emissions limits are expressed in terms of the average value of the emissions, and pulsed operation is employed, the measurement field strength shall be determined by averaging over one complete pulse train, including blanking intervals, as long as the pulse train does not exceed 0.1 seconds. As an alternative (provided the transmitter operates for longer than 0.1 seconds) or in cases where the pulse train exceeds 0.1 seconds, the measured field strength shall be determined from the average absolute voltage during a 0.1 second interval during which the field strength is at its maximum values.
8. If the emissions level of the EUT in peak mode was 3 dB lower than the average limit specified, then testing will be stopped and peak values of EUT will be reported, otherwise, the emissions which do not have 3 dB margin will be repeated one by one using the quasi-peak method for below 1GHz.
9. For testing above 1GHz, the emissions level of the EUT in peak mode was lower than average limit (that means the emissions level in peak mode also complies with the limit in average mode), then testing will be stopped and peak values of EUT will be reported, otherwise, the emissions will be measured in average mode again and reported.
10. In case the emission is lower than 30MHz, loop antenna has to be used for measurement and the recorded data should be QP measured by receiver. High - Low scan is not required in this case.

The following table is the setting of spectrum analyzer and receiver.

Spectrum Parameter	Setting
Start ~Stop Frequency	9KHz~150KHz/RB 200Hz for QP
Start ~Stop Frequency	150KHz~30MHz/RB 9KHz for QP
Start ~Stop Frequency	30MHz~1000MHz/RB 120KHz for QP
Start ~Stop Frequency	1GHz~26.5GHz 1.5MHz/1.5MHz for Peak, 1.5MHz/10Hz for Average

Receiver Parameter	Setting
Start ~Stop Frequency	9KHz~150KHz/RB 200Hz for QP
Start ~Stop Frequency	150KHz~30MHz/RB 9KHz for QP
Start ~Stop Frequency	30MHz~1000MHz/RB 120KHz for QP

8.3. TEST SETUP

Radiated Emission Test-Setup Frequency Below 30MHz

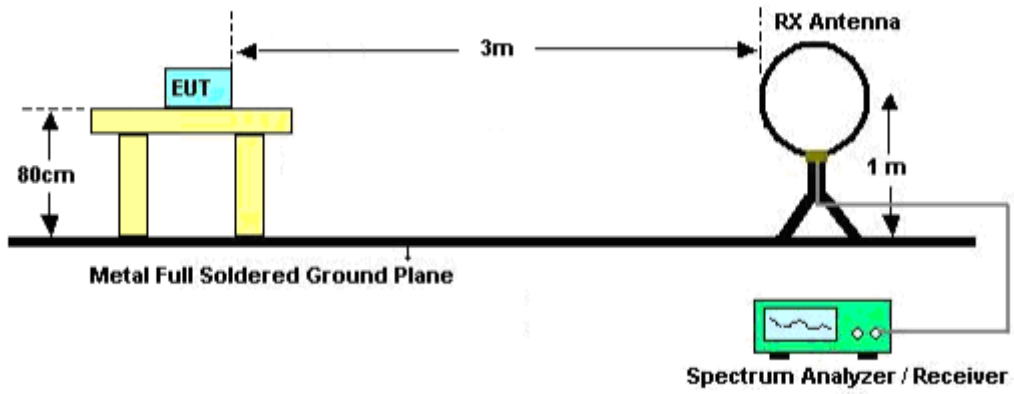

RADIATED EMISSION TEST SETUP 30MHz-1000MHz

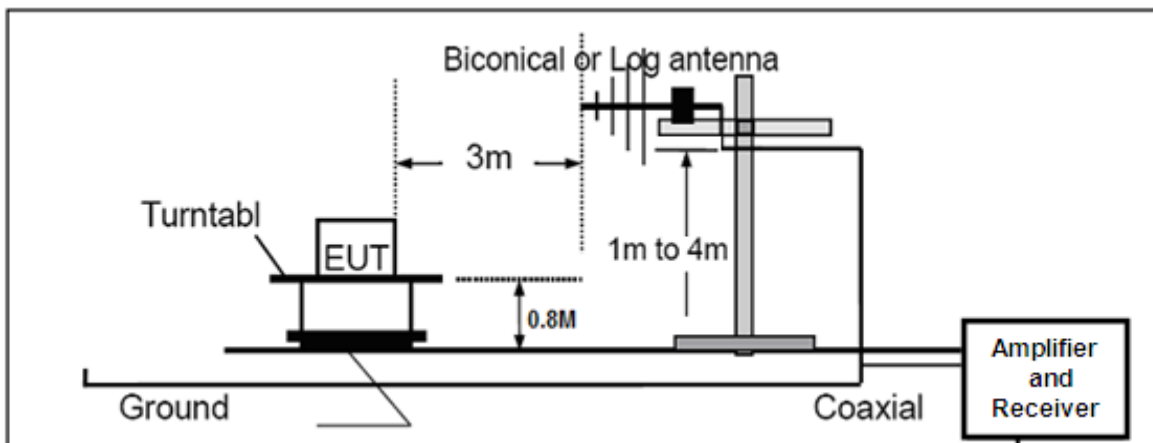

RADIATED EMISSION TEST SETUP ABOVE 1000MHz

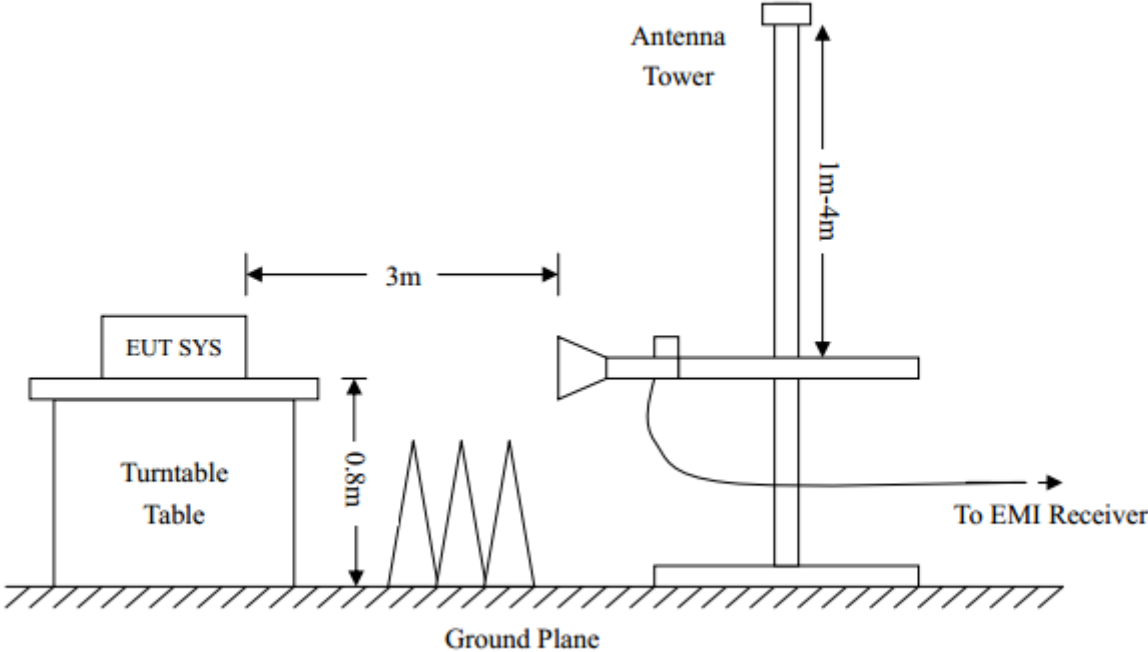

8.4. TEST RESULT

(Worst modulation:GFSK)

FOR BR/EDR

RADIATED EMISSION BELOW 30MHZ

No emission found between lowest internal used/generated frequencies to 30MHz.

RADIATED EMISSION BELOW 1GHZ

RADIATED EMISSION TEST- (30MHZ-1GHZ)-LOW CHANNEL-HORIZONTAL

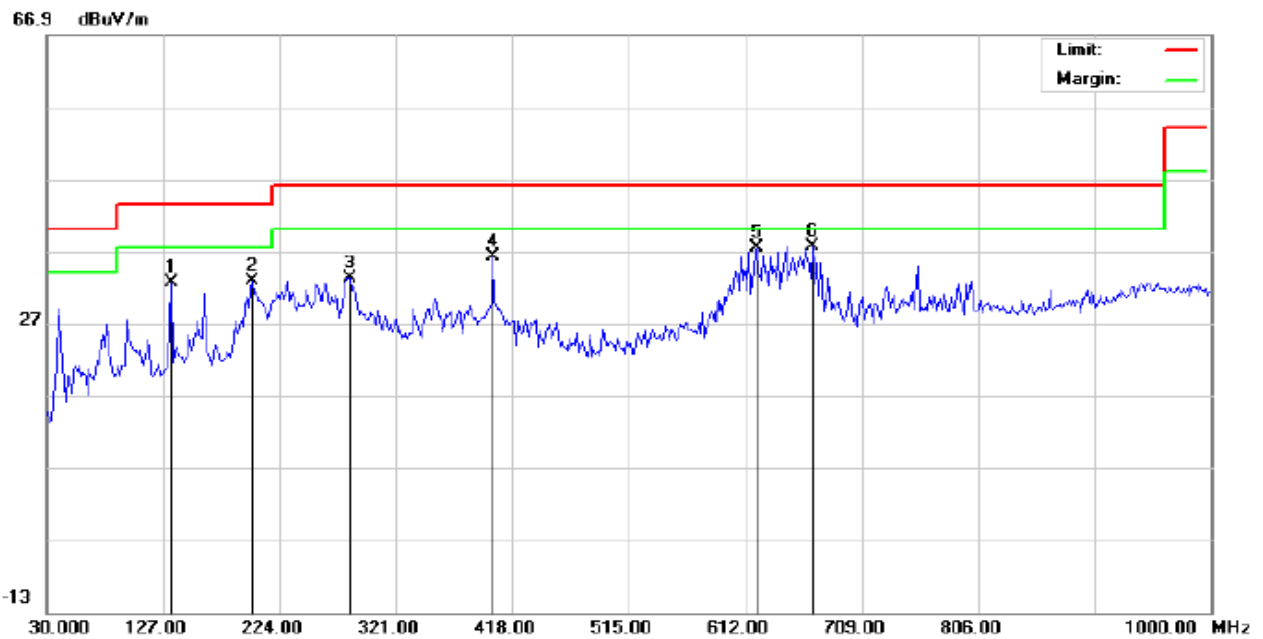

Site: site #1
Limit: FCC Class B 3M Radiation
EUT: Bluetooth Receiver
M/N: AU04
Mode: Low Channel TX
Note:

Polarization: *Horizontal*
Power:
Distance:

Temperature: 23.9
Humidity: 56.7 %

No.	Mk	Freq.	Reading	Factor	Measurement	Limit	Over	Detector	Antenna Height	Table Degree	Comment
		MHz	dBuV	dBuV/m	dBuV/m	dBuV/m	dB		cm	degree	
1		133.4667	18.49	14.11	32.60	43.50	-10.90	peak			
2		201.3667	20.68	12.05	32.73	43.50	-10.77	peak			
3		282.1999	18.34	14.87	33.21	46.00	-12.79	peak			
4		401.8333	17.05	19.13	36.18	46.00	-9.82	peak			
5		621.7000	13.57	23.78	37.35	46.00	-8.65	peak			
6	*	668.5833	13.26	24.35	37.61	46.00	-8.39	peak			

RESULT: PASS

RADIATED EMISSION TEST- (30MHZ-1GHZ)-LOW CHANNEL -VERTICAL

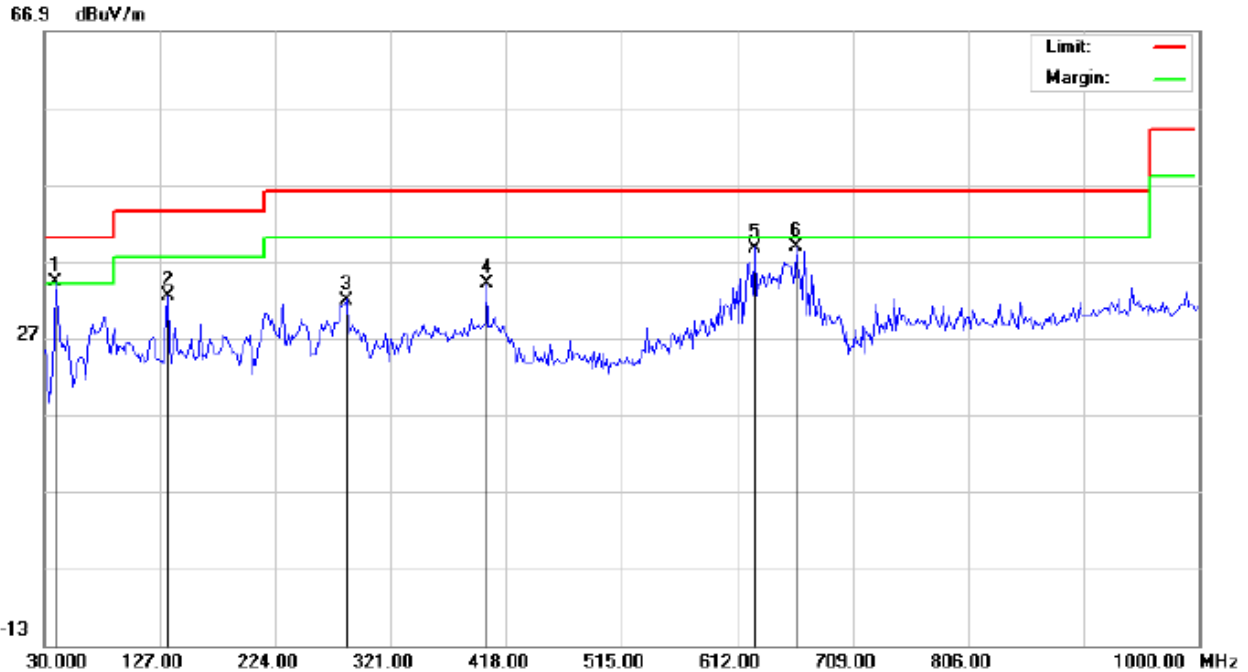

Site: site #1
Limit: FCC Class B 3M Radiation
EUT: Bluetooth Receiver
M/N: AU04
Mode: Low Channel TX
Note:

Polarization: *Vertical*
Power:
Distance:

Temperature: 23.9
Humidity: 56.7 %

No.	Mk	Freq.	Reading	Factor	Measurement	Limit	Over	Detector	Antenna Height	Table Degree	Comment
		MHz	dBuV	dBuV/m	dBuV/m	dBuV/m	dB		cm	degree	
1	*	39.7000	25.79	8.51	34.30	40.00	-5.70	peak			
2		133.4667	19.89	12.48	32.37	43.50	-11.13	peak			
3		283.8167	16.98	14.92	31.90	46.00	-14.10	peak			
4		401.8333	14.84	19.13	33.97	46.00	-12.03	peak			
5		626.5498	15.38	23.32	38.70	46.00	-7.30	peak			
6		662.1167	14.72	24.17	38.89	46.00	-7.11	peak			

RESULT: PASS

Note: 1. Factor=Antenna Factor + Cable loss, Margin=Measurement-Limit.

2. The "Factor" value can be calculated automatically by software of measurement system.

RADIATED EMISSION TEST- (30MHZ-1GHZ)-MIDDLE CHANNEL-HORIZONTAL

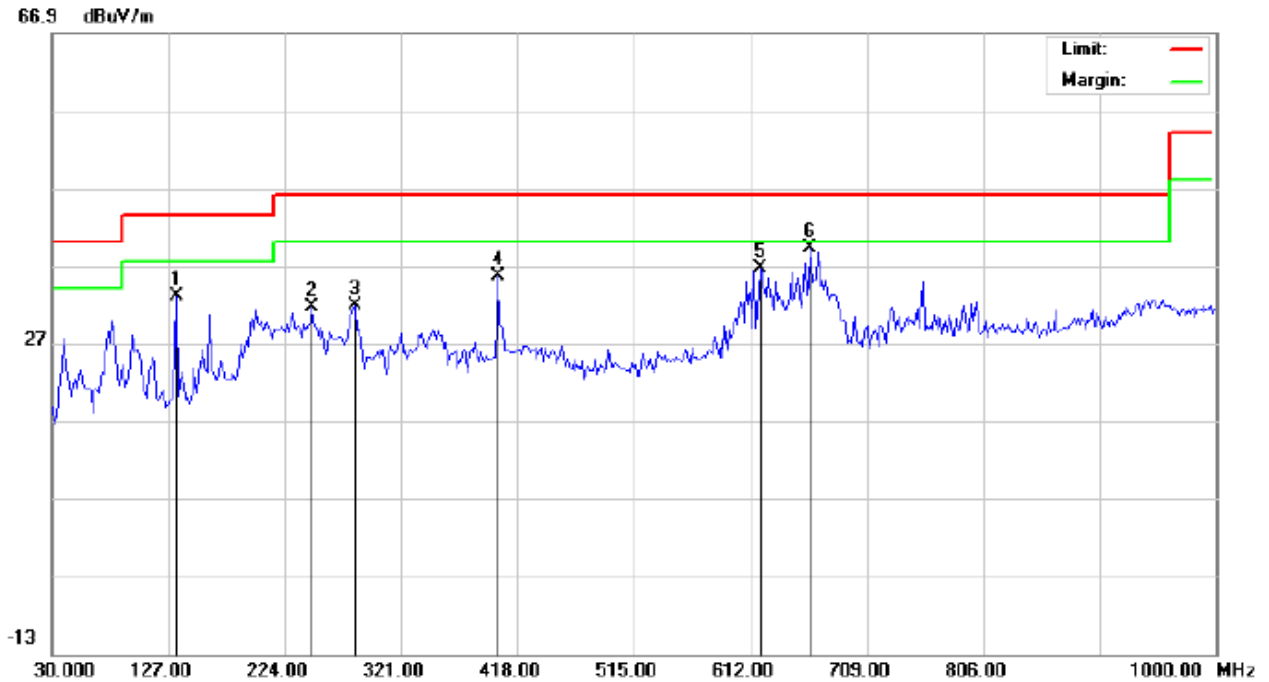

Site: site #1
Limit: FCC Class B 3M Radiation
EUT: Bluetooth Receiver
M/N: AU04
Mode: Middle Channel TX
Note:

Polarization: *Horizontal*
Power:
Distance:

Temperature: 23.9
Humidity: 56.7 %

No.	Mk	Freq.	Reading	Factor	Measurement	Limit	Over	Detector	Antenna Height	Table Degree	Comment
		MHz	dBuV	dBuV/m	dBuV/m	dBuV/m	dB		cm	degree	
1		133.4667	18.99	14.11	33.10	43.50	-10.40	peak			
2		246.6332	17.85	13.77	31.62	46.00	-14.38	peak			
3		282.1999	16.84	14.87	31.71	46.00	-14.29	peak			
4		401.8333	16.55	19.13	35.68	46.00	-10.32	peak			
5		620.0833	12.92	23.78	36.70	46.00	-9.30	peak			
6	*	662.1167	14.98	24.17	39.15	46.00	-6.85	peak			

RESULT: PASS

RADIATED EMISSION TEST- (30MHZ-1GHZ)- MIDDLE CHANNEL -VERTICAL

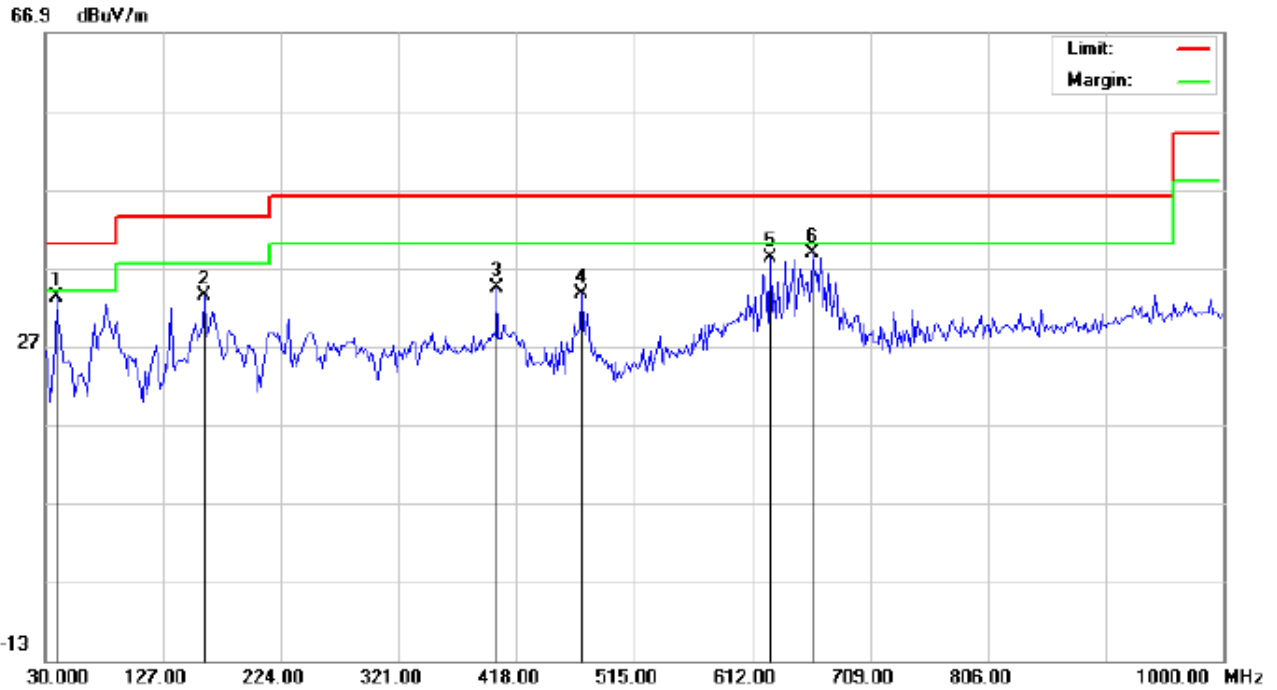

Site: site #1
Limit: FCC Class B 3M Radiation
EUT: Bluetooth Receiver
M/N: AU04
Mode: Middle Channel TX
Note:

Polarization: **Vertical**
Power:
Distance:

Temperature: 23.9
Humidity: 56.7 %

No.	Mk	Freq.	Reading	Factor	Measurement	Limit	Over	Detector	Antenna Height	Table Degree	Comment
		MHz	dBuV	dBuV/m	dBuV/m	dBuV/m	dB		cm	degree	
1	*	39.7000	24.79	8.51	33.30	40.00	-6.70	peak			
2		160.9499	18.12	15.27	33.39	43.50	-10.11	peak			
3		401.8333	15.34	19.13	34.47	46.00	-11.53	peak			
4		471.3500	12.74	20.82	33.56	46.00	-12.44	peak			
5		626.5498	14.88	23.32	38.20	46.00	-7.80	peak			
6		662.1167	14.72	24.17	38.89	46.00	-7.11	peak			

RESULT: PASS

Note: 1. Factor=Antenna Factor + Cable loss, Margin=Measurement-Limit.

2. The "Factor" value can be calculated automatically by software of measurement system.

RADIATED EMISSION TEST- (30MHZ-1GHZ)-HIGH CHANNEL-HORIZONTAL

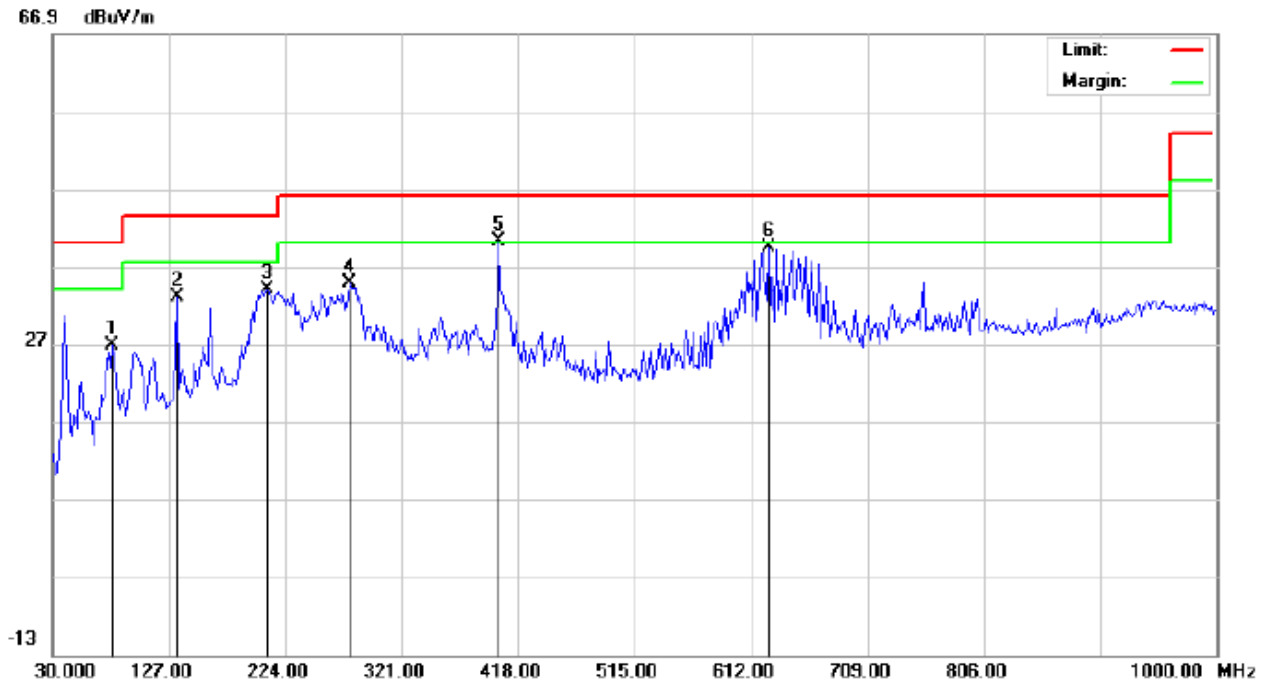

Site: site #1
Limit: FCC Class B 3M Radiation
EUT: Bluetooth Receiver
M/N: AU04
Mode: High Channel TX
Note:

Polarization: *Horizontal*
Power:
Distance:

Temperature: 23.9
Humidity: 56.7 %

No.	Mk	Freq.	Reading	Factor	Measurement	Limit	Over	Detector	Antenna Height	Table Degree	Comment
		MHz	dBuV	dBuV/m	dBuV/m	dBuV/m	dB		cm	degree	
1		80.1166	17.06	9.80	26.86	40.00	-13.14	peak			
2		133.4667	18.99	14.11	33.10	43.50	-10.40	peak			
3		209.4499	21.72	12.36	34.08	43.50	-9.42	peak			
4		277.3500	20.10	14.73	34.83	46.00	-11.17	peak			
5	*	401.8333	21.05	19.13	40.18	46.00	-5.82	peak			
6		626.5499	15.56	23.79	39.35	46.00	-6.65	peak			

RESULT: PASS

RADIATED EMISSION TEST- (30MHZ-1GHZ)-HIGH CHANNEL -VERTICAL

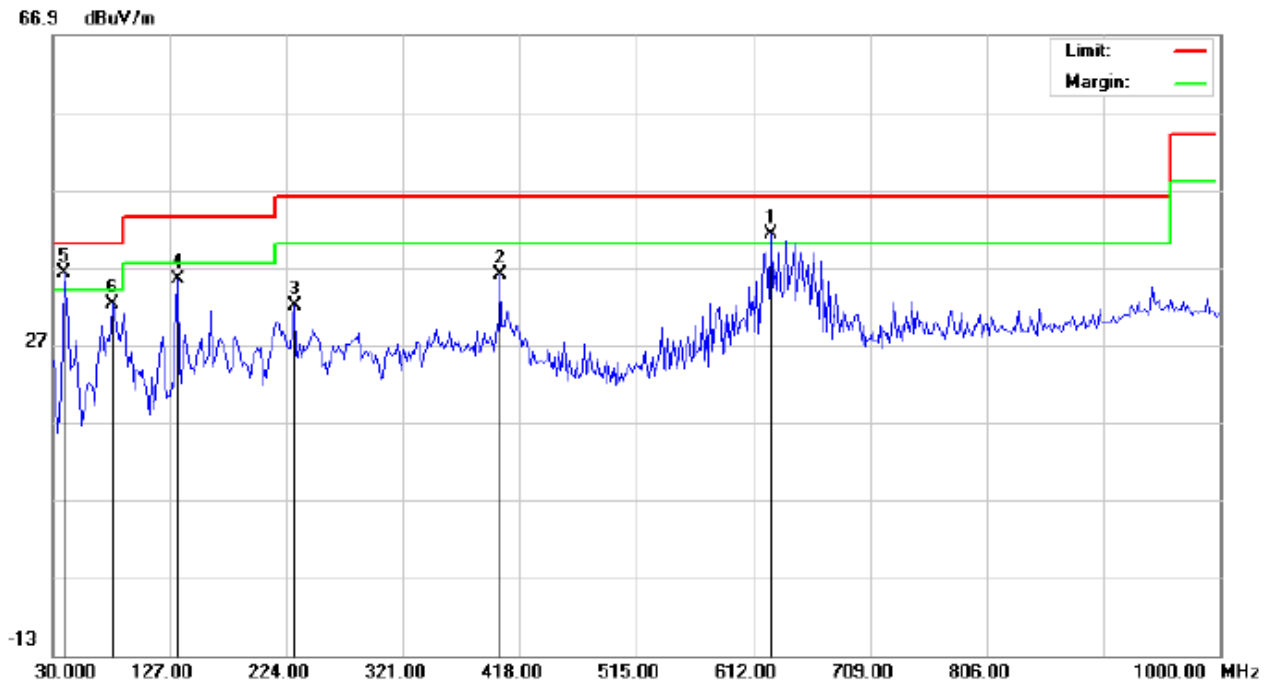

Site: site #1 Polarization: *Vertical* Temperature: 23.9
 Limit: FCC Class B 3M Radiation Power: Humidity: 56.7 %
 EUT: Bluetooth Receiver Distance:
 M/N: AU04
 Mode: High Channel TX
 Note:

No.	Mk	Freq.	Reading	Factor	Measurement	Limit	Over	Detector	Antenna Height	Table Degree	Comment
		MHz	dBuV	dBuV/m	dBuV/m	dBuV/m	dB		cm	degree	
1	!	626.5499	17.88	23.32	41.20	46.00	-4.80	peak			
2		401.8333	16.84	19.13	35.97	46.00	-10.03	peak			
3		230.4667	19.93	11.99	31.92	46.00	-14.08	peak			
4		133.4667	22.89	12.48	35.37	43.50	-8.13	peak			
5	*	39.7000	27.79	8.51	36.30	40.00	-3.70	peak			
6		80.1166	30.35	1.84	32.19	40.00	-7.81	peak			

RESULT: PASS

Note: 1. Factor=Antenna Factor + Cable loss, Margin=Measurement-Limit.

2. The "Factor" value can be calculated automatically by software of measurement system.

FOR BLE

RADIATED EMISSION BELOW 30MHZ

No emission found between lowest internal used/generated frequencies to 30MHz.

RADIATED EMISSION BELOW 1GHZ

RADIATED EMISSION TEST- (30MHZ-1GHZ)-LOW CHANNEL-HORIZONTAL

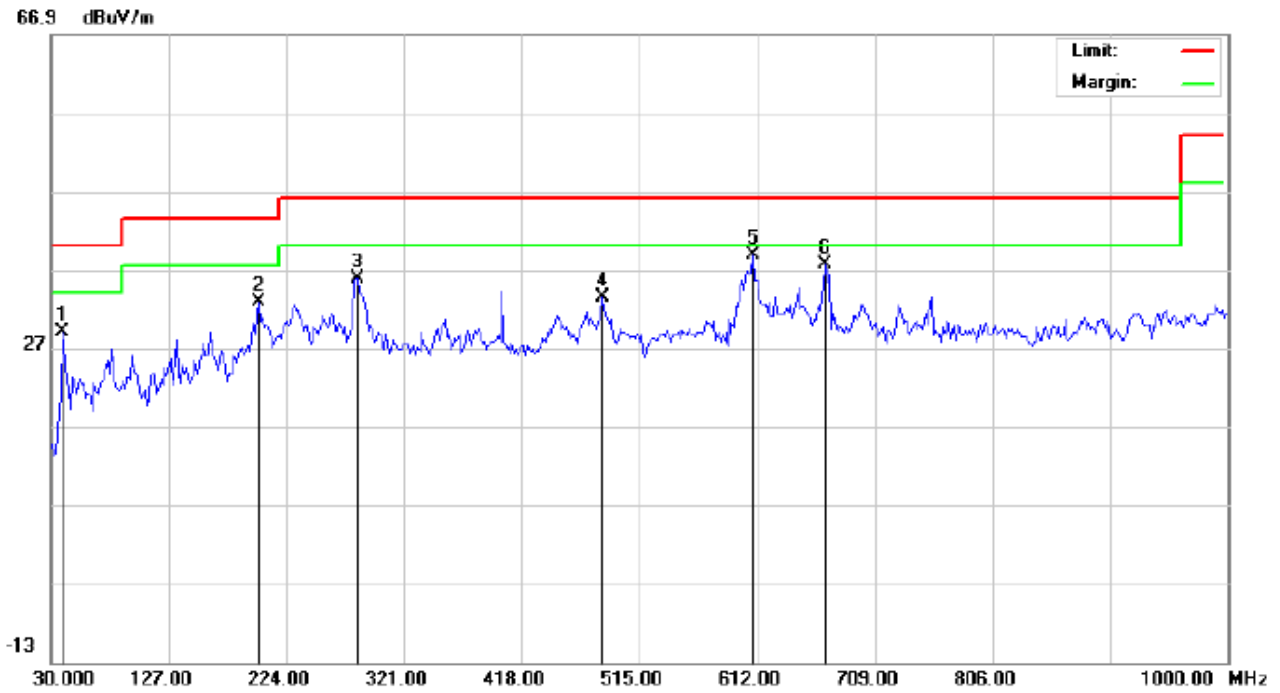

Site: site #1	Polarization: <i>Horizontal</i>	Temperature: 23.9
Limit: FCC Class B 3M Radiation	Power:	Humidity: 56.7 %
EUT: Bluetooth Receiver	Distance:	
M/N: AU04		
Mode: Low Channel TX		
Note:		

No.	Mk	Freq.	Reading	Factor	Measurement	Limit	Over	Detector	Antenna Height	Table Degree	Comment
		MHz	dBuV	dBuV/m	dBuV/m	dBuV/m	dB		cm	degree	
1		39.7000	17.49	11.51	29.00	40.00	-11.00	peak			
2		201.3667	20.68	12.05	32.73	43.50	-10.77	peak			
3		282.1999	20.84	14.87	35.71	46.00	-10.29	peak			
4		484.2832	12.54	20.96	33.50	46.00	-12.50	peak			
5	*	608.7667	14.99	23.75	38.74	46.00	-7.26	peak			
6		668.5833	13.26	24.35	37.61	46.00	-8.39	peak			

RESULT: PASS

RADIATED EMISSION TEST- (30MHZ-1GHZ)-LOW CHANNEL -VERTICAL

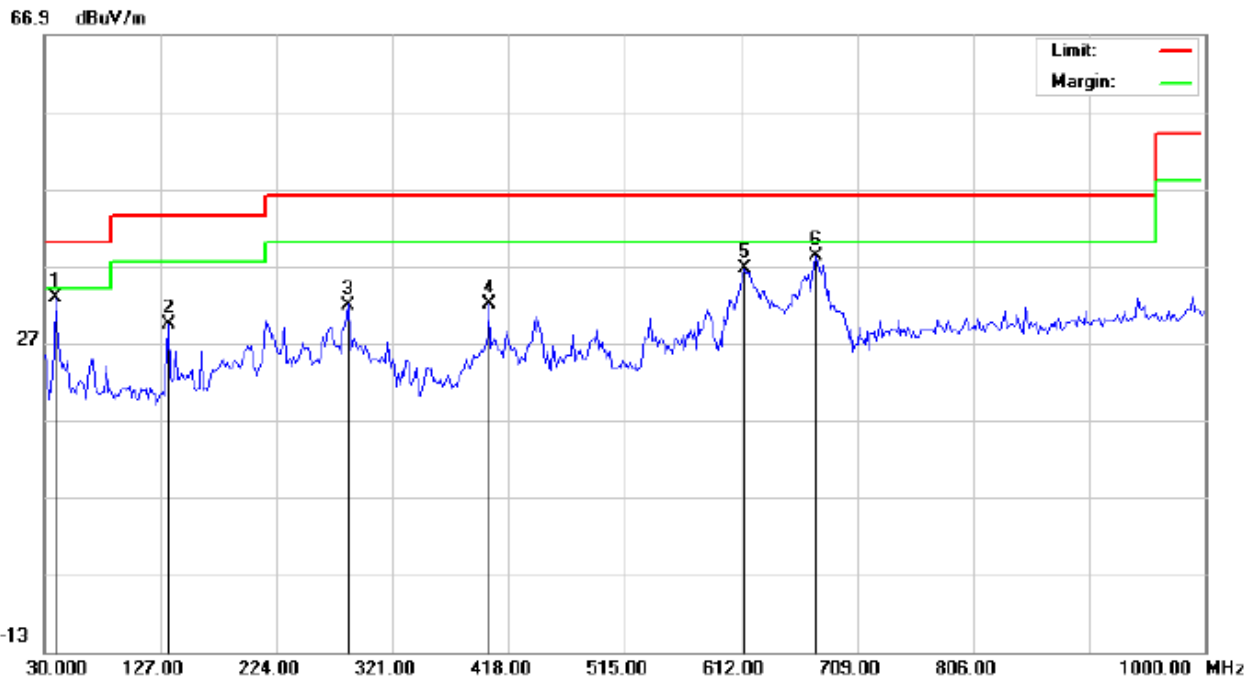

Site: site #1
Limit: FCC Class B 3M Radiation
EUT: Bluetooth Receiver
M/N: AU04
Mode: Low Channel TX
Note:

Polarization: **Vertical**
Power:
Distance:

Temperature: 23.9
Humidity: 56.7 %

No.	Mk	Freq.	Reading	Factor	Measurement	Limit	Over	Detector	Antenna Height	Table Degree	Comment
		MHz	dBuV	dBuV/m	dBuV/m	dBuV/m	dB		cm	degree	
1	*	39.7000	24.29	8.51	32.80	40.00	-7.20	peak			
2		133.4667	16.89	12.48	29.37	43.50	-14.13	peak			
3		283.8167	16.98	14.92	31.90	46.00	-14.10	peak			
4		401.8333	12.84	19.13	31.97	46.00	-14.03	peak			
5		615.2332	13.58	23.07	36.65	46.00	-9.35	peak			
6		675.0498	13.66	24.52	38.18	46.00	-7.82	peak			

RESULT: PASS

Note: 1. Factor=Antenna Factor + Cable loss, Margin=Measurement-Limit.

2. The "Factor" value can be calculated automatically by software of measurement system.

RADIATED EMISSION TEST- (30MHZ-1GHZ)-MIDDLE CHANNEL-HORIZONTAL

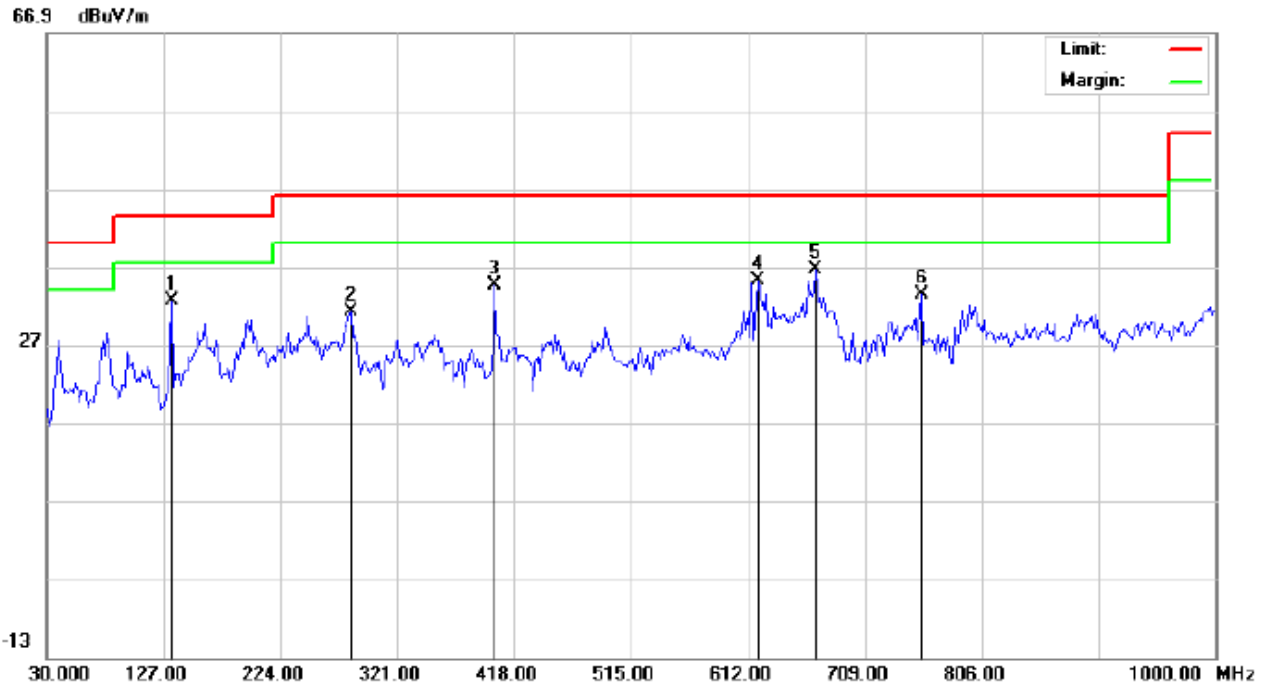

Site: site #1
Limit: FCC Class B 3M Radiation
EUT: Bluetooth Receiver
M/N: AU04
Mode: Middle Channel TX
Note:

Polarization: *Horizontal*
Power:
Distance:

Temperature: 23.9
Humidity: 56.7 %

No.	Mk	Freq.	Reading	Factor	Measurement	Limit	Over	Detector	Antenna Height	Table Degree	Comment
		MHz	dBuV	dBuV/m	dBuV/m	dBuV/m	dB		cm	degree	
1		133.4667	18.49	14.11	32.60	43.50	-10.90	peak			
2		282.1999	16.34	14.87	31.21	46.00	-14.79	peak			
3		401.8333	15.55	19.13	34.68	46.00	-11.32	peak			
4		620.0833	11.42	23.78	35.20	46.00	-10.80	peak			
5	*	668.5833	12.26	24.35	36.61	46.00	-9.39	peak			
6		755.8831	6.65	26.71	33.36	46.00	-12.64	peak			

RESULT: PASS

RADIATED EMISSION TEST- (30MHZ-1GHZ)- MIDDLE CHANNEL -VERTICAL

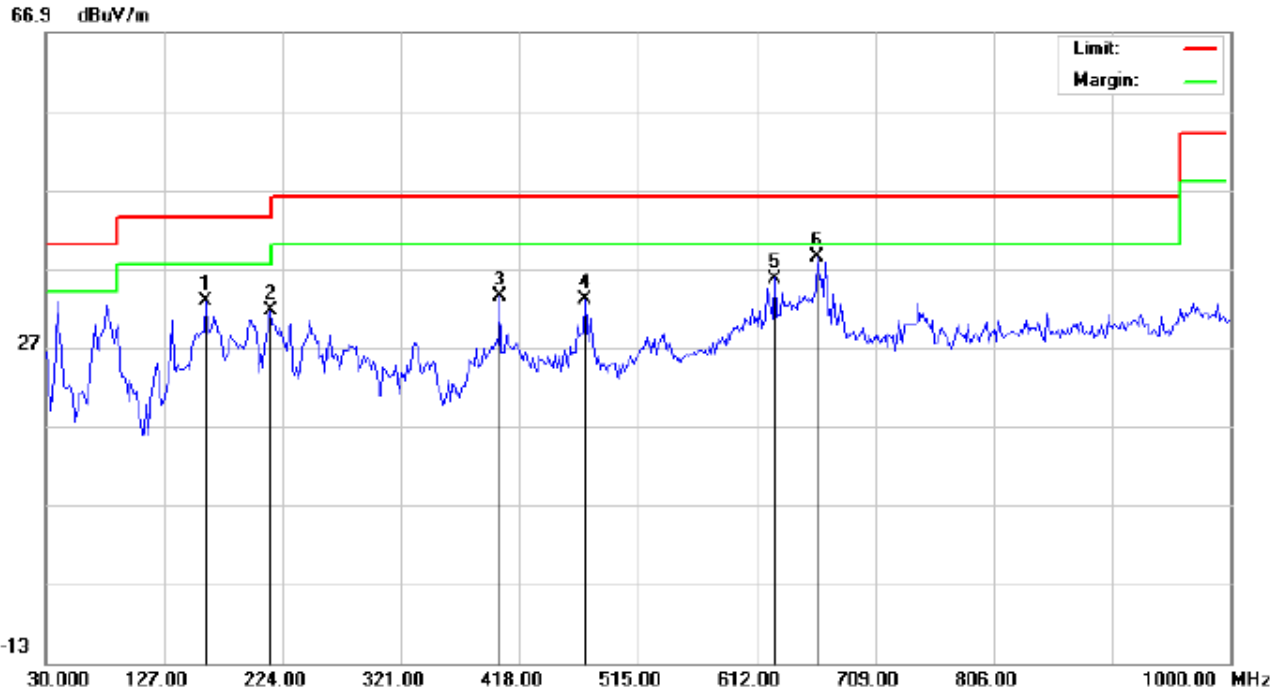

Site: site #1
 Limit: FCC Class B 3M Radiation
 EUT: Bluetooth Receiver
 M/N: AU04
 Mode: Middle Channel TX
 Note:

Polarization: *Vertical*
 Power:
 Distance:

Temperature: 23.9
 Humidity: 56.7 %

No.	Mk	Freq.	Reading	Factor	Measurement	Limit	Over	Detector	Antenna Height	Table Degree	Comment
		MHz	dBuV	dBuV/m	dBuV/m	dBuV/m	dB		cm	degree	
1		160.9499	17.62	15.27	32.89	43.50	-10.61	peak			
2		214.3000	21.24	10.40	31.64	43.50	-11.86	peak			
3		401.8333	14.34	19.13	33.47	46.00	-12.53	peak			
4		471.3500	12.24	20.82	33.06	46.00	-12.94	peak			
5		626.5498	12.38	23.32	35.70	46.00	-10.30	peak			
6	*	662.1167	14.22	24.17	38.39	46.00	-7.61	peak			

RESULT: PASS

Note: 1. Factor=Antenna Factor + Cable loss, Margin=Measurement-Limit.

2. The "Factor" value can be calculated automatically by software of measurement system.

RADIATED EMISSION TEST- (30MHZ-1GHZ)-HIGH CHANNEL-HORIZONTAL

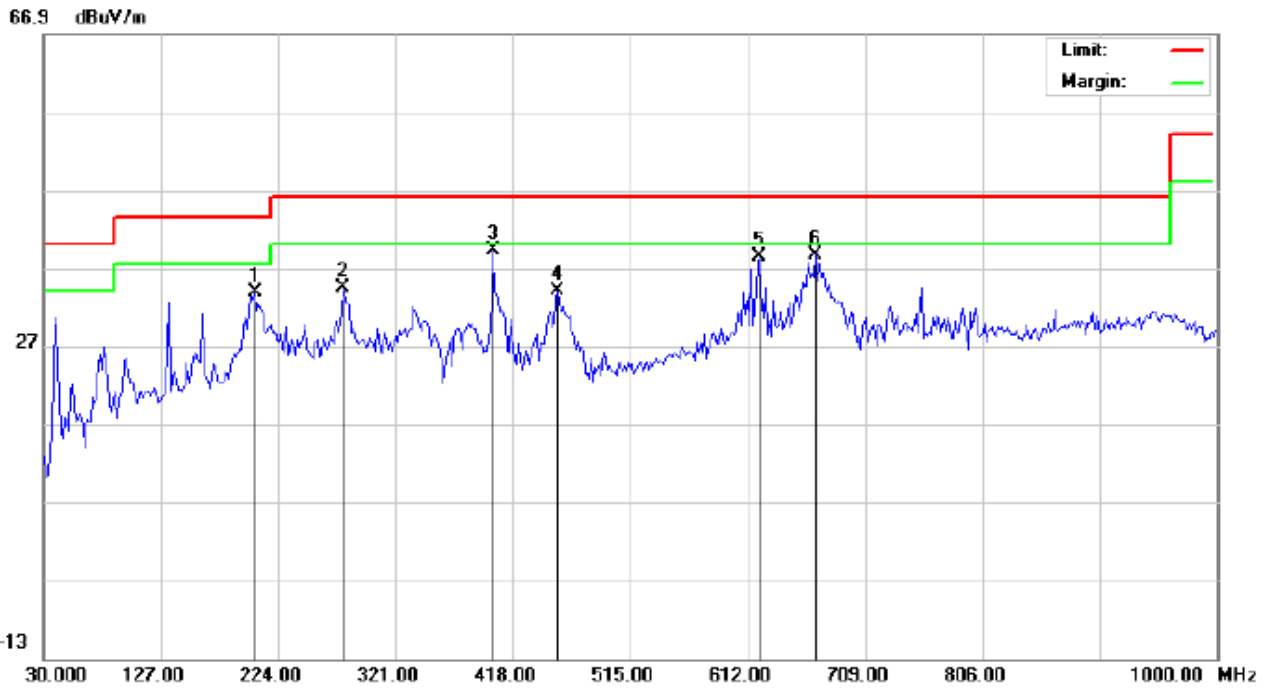

Site: site #1
 Limit: FCC Class B 3M Radiation
 EUT: Bluetooth Receiver
 M/N: AU04
 Mode: High Channel TX
 Note:

Polarization: *Horizontal*
 Power:
 Distance:

Temperature: 23.9
 Humidity: 56.7 %

No.	Mk	Freq.	Reading	Factor	Measurement	Limit	Over	Detector	Antenna Height	Table Degree	Comment
		MHz	dBuV	dBuV/m	dBuV/m	dBuV/m	dB		cm	degree	
1		204.5999	21.63	12.17	33.80	43.50	-9.70	peak			
2		277.3500	19.60	14.73	34.33	46.00	-11.67	peak			
3	*	401.8333	20.05	19.13	39.18	46.00	-6.82	peak			
4		455.1831	13.36	20.65	34.01	46.00	-11.99	peak			
5		621.7000	14.57	23.78	38.35	46.00	-7.65	peak			
6		668.5833	14.26	24.35	38.61	46.00	-7.39	peak			

RESULT: PASS

RADIATED EMISSION TEST- (30MHZ-1GHZ)-HIGH CHANNEL -VERTICAL

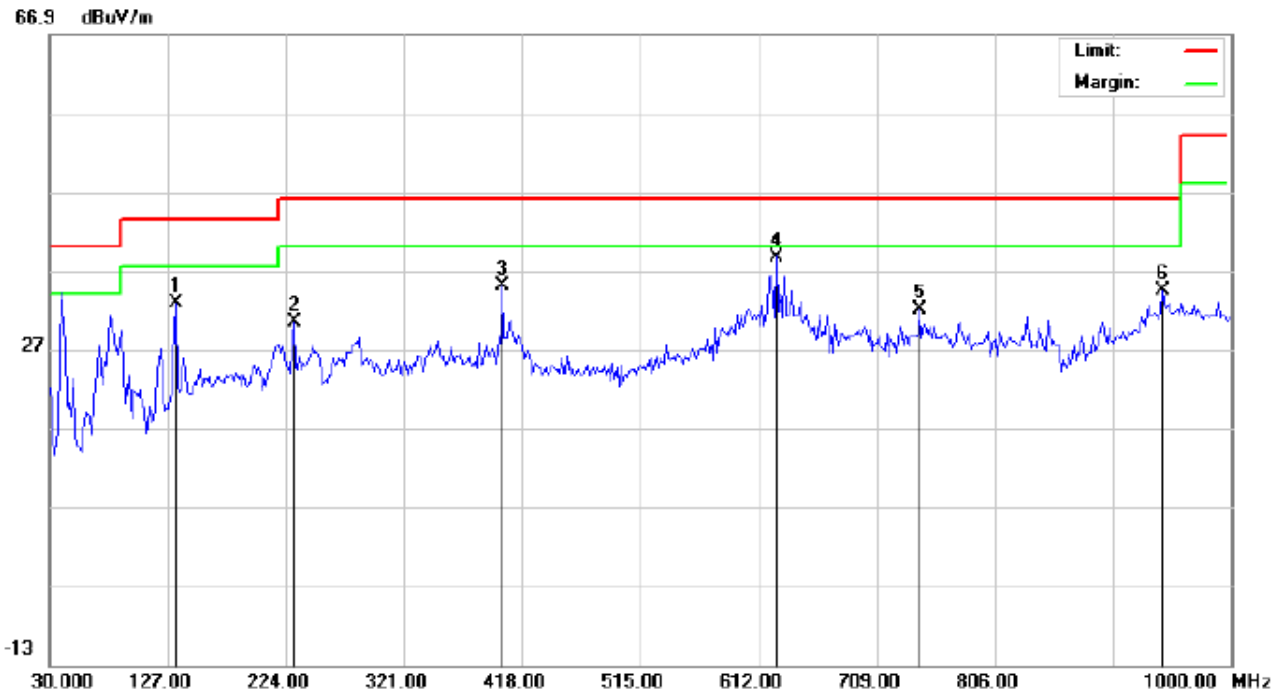

Site: site #1
Limit: FCC Class B 3M Radiation
EUT: Bluetooth Receiver
M/N: AU04
Mode: High Channel TX
Note:

Polarization: *Vertical*
Power:
Distance:

Temperature: 23.9
Humidity: 56.7 %

No.	Mk	Freq.	Reading	Factor	Measurement	Limit	Over	Detector	Antenna Height	Table Degree	Comment
		MHz	dBuV	dBuV/m	dBuV/m	dBuV/m	dB		cm	degree	
1		133.4667	20.39	12.48	32.87	43.50	-10.63	peak			
2		230.4667	18.43	11.99	30.42	46.00	-15.58	peak			
3		401.8333	15.84	19.13	34.97	46.00	-11.03	peak			
4	*	626.5498	15.38	23.32	38.70	46.00	-7.30	peak			
5		744.5665	5.61	26.47	32.08	46.00	-13.92	peak			
6		943.4166	4.57	29.82	34.39	46.00	-11.61	peak			

RESULT: PASS

Note: 1. Factor=Antenna Factor + Cable loss, Margin=Measurement-Limit.

2. The "Factor" value can be calculated automatically by software of measurement system.

**RADIATED EMISSION ABOVE 1GHZ
FOR BR/EDR**

RADIATED EMISSION TEST- (ABOVE 1GHZ)-LOW CHANNEL-HORIZONTAL

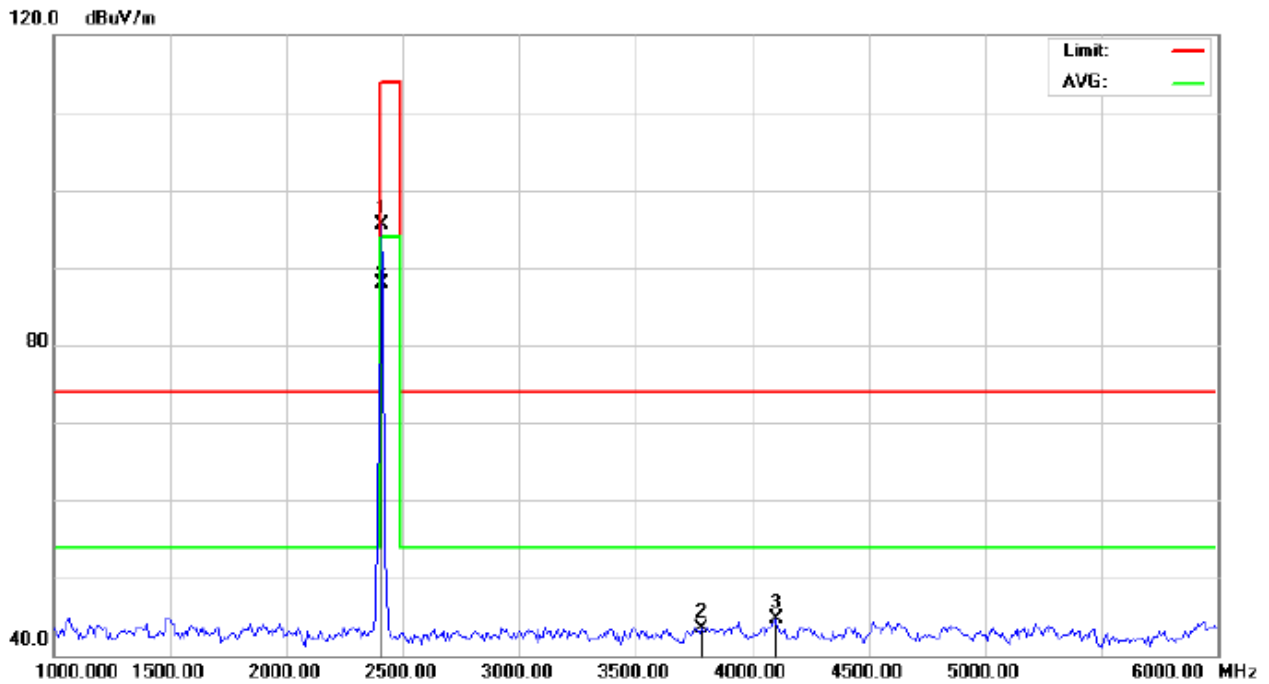

Site: site #1
Limit: FCC Class B 3M Radiation above 1GHZ(PK)-
EUT: Bluetooth Receiver
M/N: AU04
Mode: Low Channel TX
Note:

Polarization: *Horizontal*
Power:
Distance: 3m

Temperature: 26
Humidity: 60 %

No.	Mk	Freq.	Reading	Factor	Measurement	Limit	Over	Detector	Antenna Height	Table Degree	Comment
		MHz	dBuV	dBuV/m	dBuV/m	dBuV/m	dB		cm	degree	
1		2402.000	105.19	-9.68	95.51	114.00	-18.49	peak			
2		3783.333	49.72	-6.14	43.58	74.00	-30.42	peak			
3		4100.000	49.10	-4.47	44.63	74.00	-29.37	peak			
4	*	2402.000	97.51	-9.68	87.83	94.00	-6.17	AVG	100	336	

RESULT: PASS

RADIATED EMISSION TEST- (ABOVE 1GHZ)-LOW CHANNEL- VERTICAL

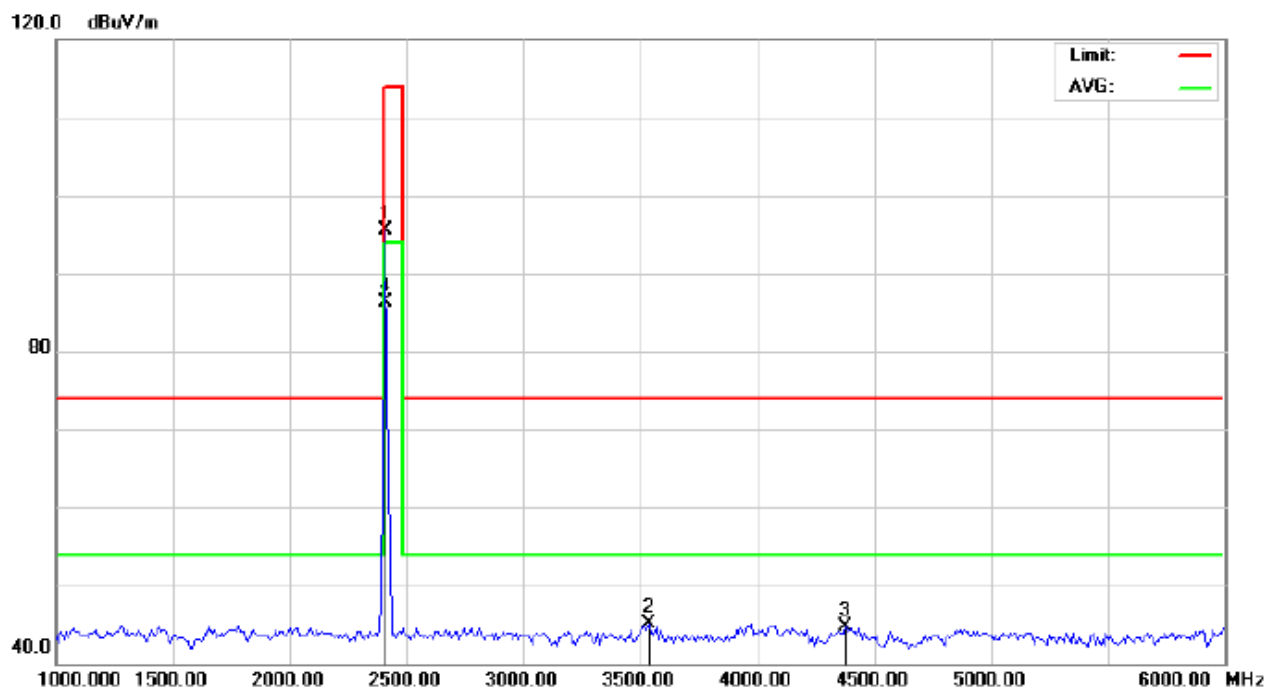

Site: site #1 Polarization: **Vertical** Temperature: 26
 Limit: FCC Class B 3M Radiation above 1GHZ(PK)- Power: Humidity: 60 %
 EUT: Bluetooth Receiver Distance: 3m
 M/N: AU04
 Mode: Low Channel TX
 Note:

No.	Mk	Freq.	Reading	Factor	Measurement	Limit	Over	Detector	Antenna Height	Table Degree	Comment
		MHz	dBuV	dBuV/m	dBuV/m	dBuV/m	dB		cm	degree	
1		2402.000	105.16	-9.68	95.48	114.00	-18.52	peak			
2		3533.333	52.81	-7.68	45.13	74.00	-28.87	peak			
3		4375.000	48.20	-3.53	44.67	74.00	-29.33	peak			
4	*	2402.000	96.05	-9.68	86.37	94.00	-7.63	AVG	100	133	

RESULT: PASS

RADIATED EMISSION TEST- (ABOVE 1GHZ)-MIDDLE CHANNEL-HORIZONTAL

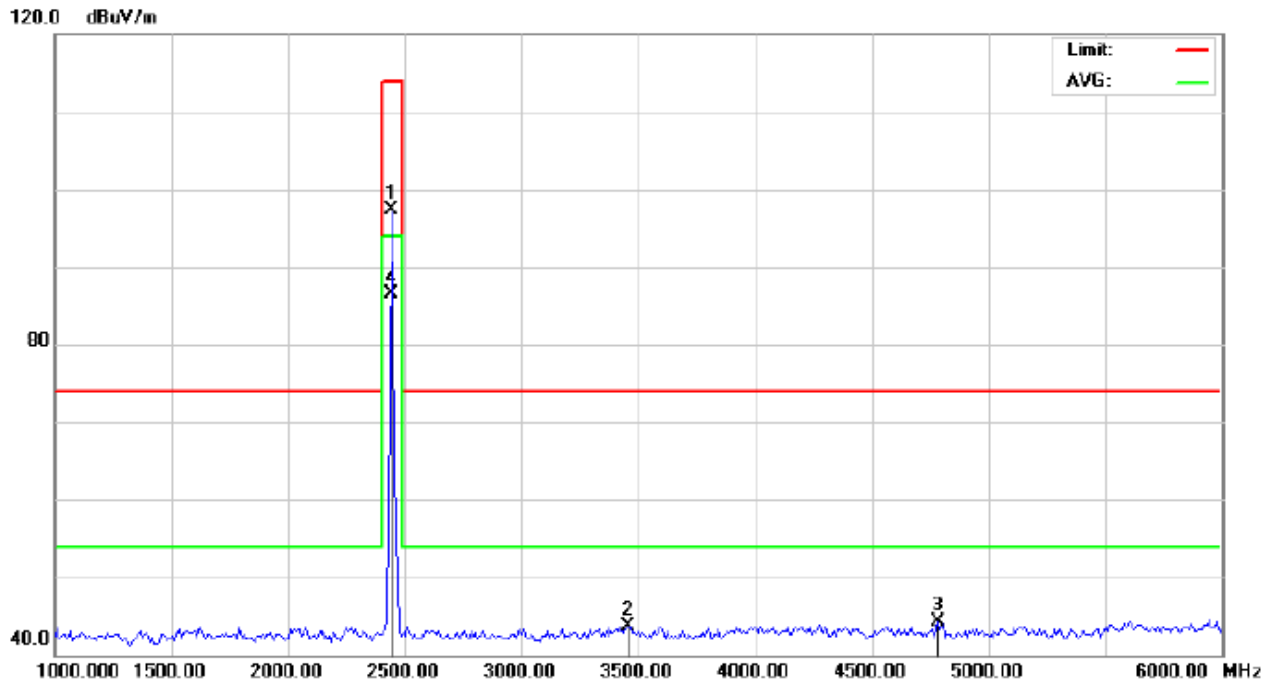

Site: site #1
 Limit: FCC Class B 3M Radiation above 1GHZ(PK)-
 EUT: Buetooth Receiver
 M/N: AU04
 Mode: Middle Channel TX
 Note:

Polarization: *Horizontal*
 Power:
 Distance: 3m

Temperature: 26
 Humidity: 60 %

No.	Mk	Freq.	Reading	Factor	Measurement	Limit	Over	Detector	Antenna Height	Table Degree	Comment
		MHz	dBuV	dBuV/m	dBuV/m	dBuV/m	dB		cm	degree	
1		2441.000	106.86	-9.63	97.23	114.00	-16.77	peak			
2		3458.333	51.71	-7.93	43.78	74.00	-30.22	peak			
3		4783.333	46.62	-2.37	44.25	74.00	-29.75	peak			
4	*	2441.000	96.12	-9.63	86.49	94.00	-7.51	AVG	100	334	

RESULT: PASS

RADIATED EMISSION TEST- (ABOVE 1GHZ)-MIDDLE CHANNEL- VERTICAL

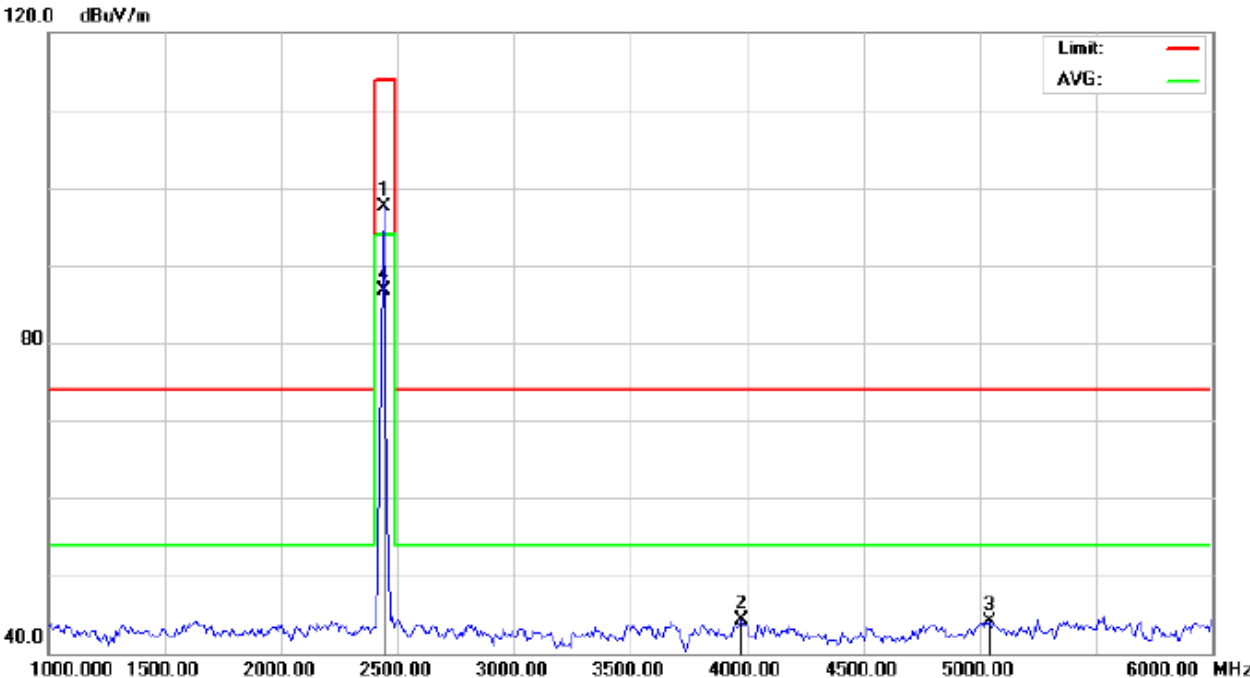

Site: site #1
 Limit: FCC Class B 3M Radiation above 1GHZ(PK)-
 EUT: Buetooth Receiver
 M/N: AU04
 Mode: Middle Channel TX
 Note:

Polarization: *Vertical*
 Power:
 Distance: 3m

Temperature: 26
 Humidity: 60 %

No.	Mk	Freq.	Reading	Factor	Measurement	Limit	Over	Detector	Antenna Height	Table Degree	Comment
		MHz	dBuV	dBuV/m	dBuV/m	dBuV/m	dB		cm	degree	
1		2441.000	107.20	-9.63	97.57	114.00	-16.43	peak			
2		3975.000	49.36	-4.96	44.40	74.00	-29.60	peak			
3		5041.667	45.93	-1.80	44.13	74.00	-29.87	peak			
4	*	2441.000	96.37	-9.63	86.74	94.00	-7.26	AVG	100	129	

RESULT: PASS

RADIATED EMISSION TEST- (ABOVE 1GHZ)-HIGH CHANNEL-HORIZONTAL

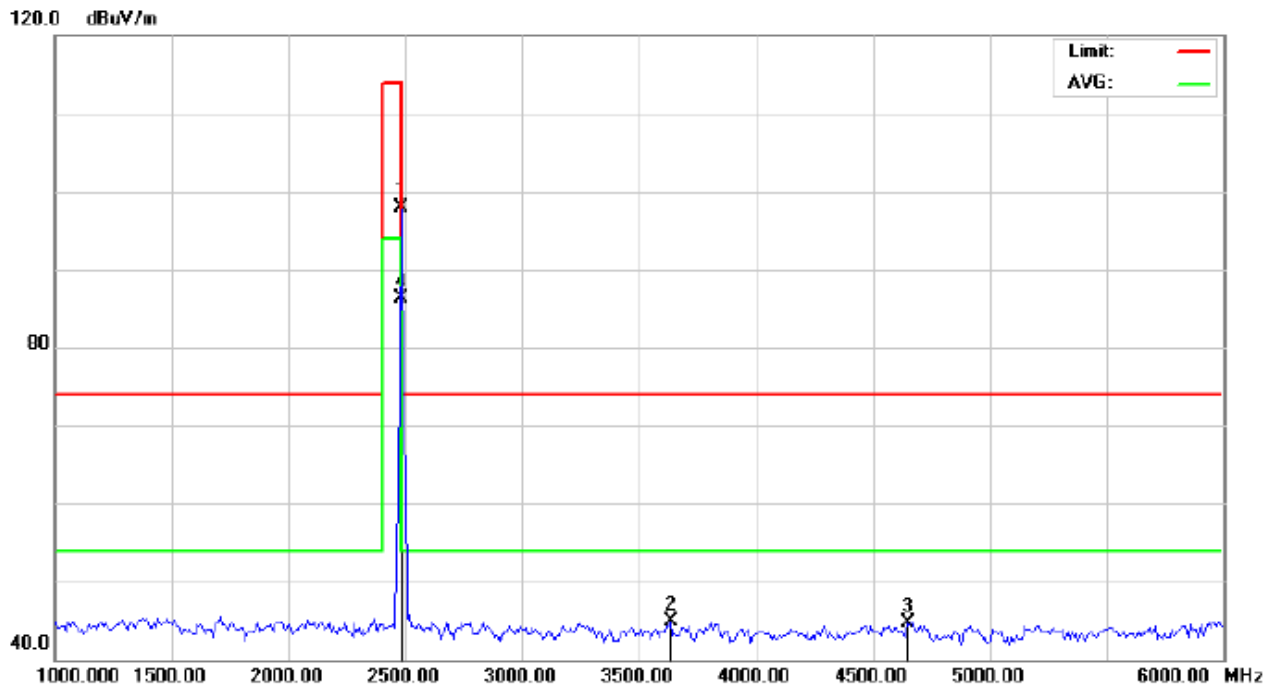

Site: site #1 Polarization: *Horizontal* Temperature: 26
Limit: FCC Class B 3M Radiation above 1GHZ(PK)- Power: Humidity: 60 %
EUT: Bluetooth Receiver Distance: 3m
M/N: AU04
Mode: High Channel TX
Note:

No.	Mk	Freq.	Reading	Factor	Measurement	Limit	Over	Detector	Antenna Height	Table Degree	Comment
		MHz	dBuV	dBuV/m	dBuV/m	dBuV/m	dB		cm	degree	
1		2480.000	107.40	-9.59	97.81	114.00	-16.19	peak			
2		3633.333	51.89	-7.07	44.82	74.00	-29.18	peak			
3		4650.000	47.52	-2.72	44.80	74.00	-29.20	peak			
4	*	2480.000	95.94	-9.59	86.35	94.00	-7.65	AVG	100	329	

RESULT: PASS

RADIATED EMISSION TEST- (ABOVE 1GHZ)-HIGH CHANNEL- VERTICAL

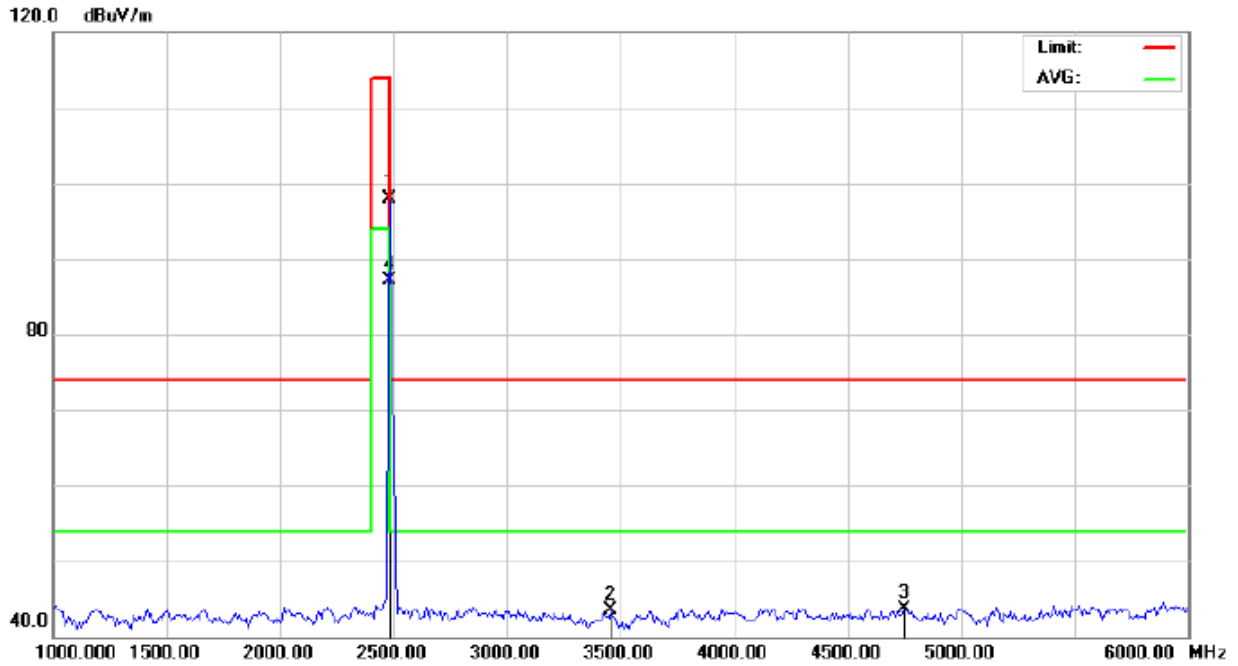

Site: site #1 Polarization: *Vertical* Temperature: 26
Limit: FCC Class B 3M Radiation above 1GHZ(PK)- Power: Humidity: 60 %
EUT: Buetooth Receiver Distance: 3m
M/N: AU04
Mode: High Channel TX
Note:

No.	Mk	Freq.	Reading	Factor	Measurement	Limit	Over	Detector	Antenna	Table	Comment
		MHz	dBuV	dBuV/m	dBuV/m	dBuV/m	dB		Height	Degree	
									cm	degree	
1		2480.000	107.43	-9.59	97.84	114.00	-16.16	peak			
2		3458.333	51.52	-7.93	43.59	74.00	-30.41	peak			
3		4750.000	46.13	-2.45	43.68	74.00	-30.32	peak			
4	*	2480.000	96.78	-9.59	87.19	94.00	-6.81	AVG	100	131	

RESULT: PASS

Note: 6~25GHz at least have 20dB margin. No recording in the test report.

Factor=Antenna Factor + Cable loss - Amplifier gain, Margin=Measurement-Limit.

The "Factor" value can be calculated automatically by software of measurement system.

Field strength of the fundamental signal

Peak value

Frequency	Reading Level	Factor	Measurement	Limit	Over	Antenna
(MHz)	(dBuv)	(dB/m)	(dBuv/m)	(dBuv/m)	(dB)	Polarization
2402	105.19	-9.68	95.51	114	-18.49	Horizontal
2402	105.16	-9.68	95.48	114	-18.52	Vertical
2441	106.86	-9.63	97.23	114	-16.77	Horizontal
2441	107.20	-9.63	97.57	114	-16.43	Vertical
2480	107.40	-9.59	97.81	114	-16.19	Horizontal
2480	107.43	-9.59	97.84	114	-16.16	Vertical

Average value

Frequency	Reading Level	Factor	Measurement	Limit	Over	Antenna
(MHz)	(dBuv)	(dB/m)	(dBuv/m)	(dBuv/m)	(dB)	Polarization
2402	97.51	-9.68	87.83	94	-6.17	Horizontal
2402	96.05	-9.68	86.37	94	-7.63	Vertical
2441	96.12	-9.63	86.49	94	-7.51	Horizontal
2441	96.37	-9.63	86.74	94	-7.26	Vertical
2480	95.94	-9.59	86.35	94	-7.65	Horizontal
2480	96.78	-9.59	87.19	94	-6.81	Vertical

FOR BLE

RADIATED EMISSION TEST- (ABOVE 1GHZ)-LOW CHANNEL-HORIZONTAL

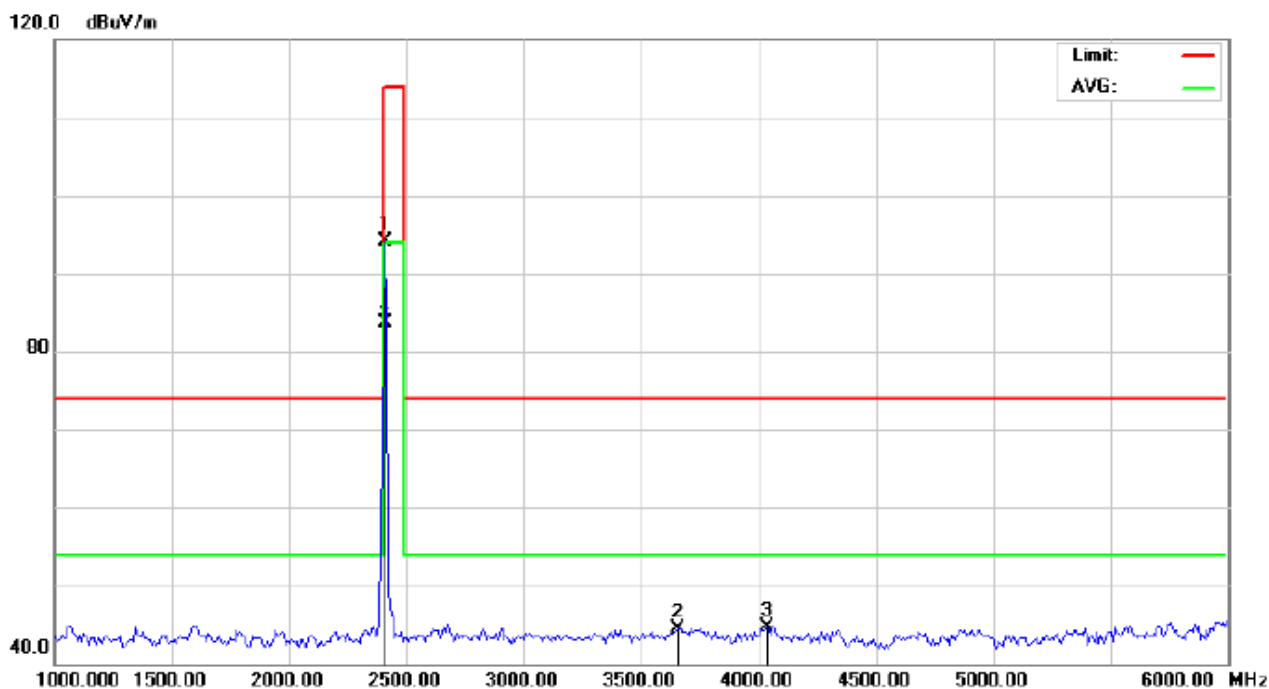

Site: site #1

Polarization: *Horizontal*

Temperature: 26

Limit: FCC Class B 3M Radiation above 1GHZ(PK)-

Power:

Humidity: 60 %

EUT: Bluetooth Receiver

Distance: 3m

M/N: AU04

Mode: Low Channel TX

Note:

No.	Mk	Freq.	Reading	Factor	Measurement	Limit	Over	Detector	Antenna Height	Table Degree	Comment
		MHz	dBuV	dBuV/m	dBuV/m	dBuV/m	dB		cm	degree	
1		2402.000	103.79	-9.68	94.11	114.00	-19.89	peak			
2		3658.333	51.50	-6.91	44.59	74.00	-29.41	peak			
3		4033.333	49.40	-4.70	44.70	74.00	-29.30	peak			
4	*	2402.000	93.40	-9.68	83.72	94.00	-10.28	AVG	100	341	

RESULT: PASS

RADIATED EMISSION TEST- (ABOVE 1GHZ)-LOW CHANNEL- VERTICAL

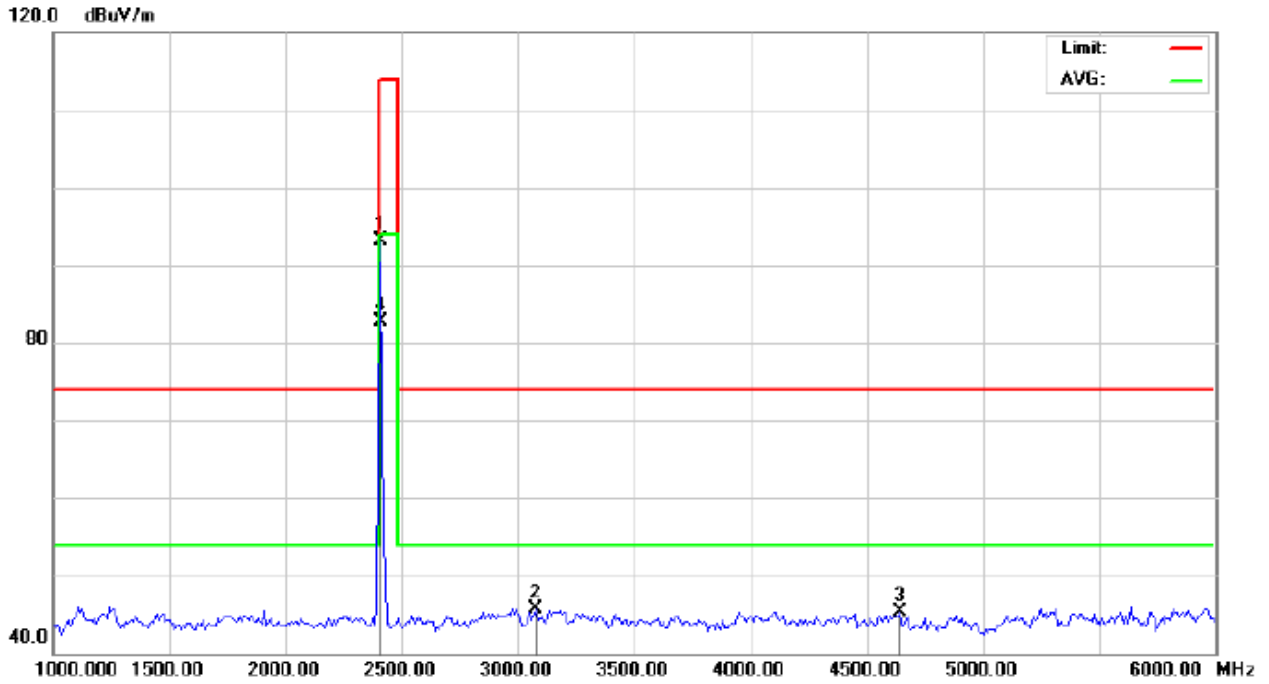

Site: site #1
 Limit: FCC Class B 3M Radiation above 1GHZ(PK)-
 EUT: Bluetooth Receiver
 M/N: AU04
 Mode: Low Channel TX
 Note:

Polarization: *Vertical*
 Power:
 Distance: 3m

Temperature: 26
 Humidity: 60 %

No.	Mk	Freq.	Reading	Factor	Measurement	Limit	Over	Detector	Antenna Height	Table Degree	Comment
		MHz	dBuV	dBuV/m	dBuV/m	dBuV/m	dB		cm	degree	
1		2402.000	102.75	-9.68	93.07	114.00	-20.93	peak			
2		3075.000	54.05	-8.29	45.76	74.00	-28.24	peak			
3		4641.667	47.95	-2.74	45.21	74.00	-28.79	peak			
4	*	2402.000	92.46	-9.68	82.78	94.00	-11.22	AVG	100	119	

RESULT: PASS

RADIATED EMISSION TEST- (ABOVE 1GHZ)-MIDDLE CHANNEL-HORIZONTAL

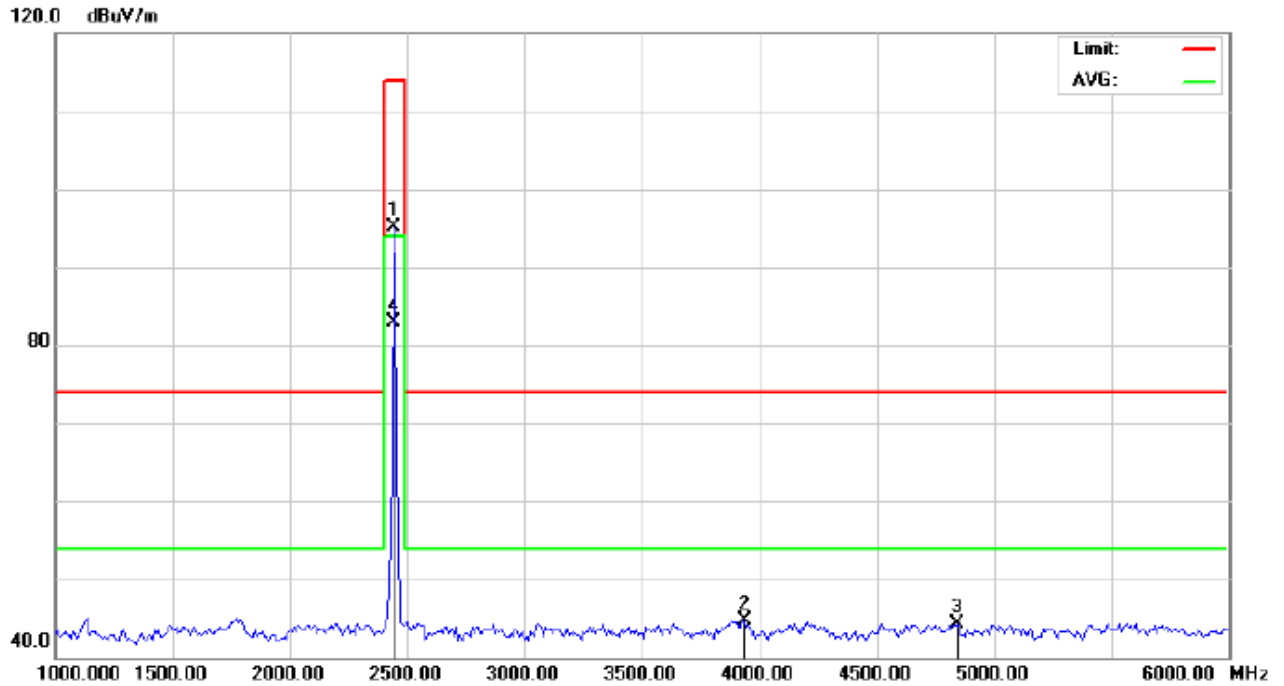

Site: site #1
Limit: FCC Class B 3M Radiation above 1GHZ(PK)-
EUT: Bluetooth Receiver
M/N: AU04
Mode: Middle Channel TX
Note:

Polarization: *Horizontal*
Power:
Distance: 3m

Temperature: 26
Humidity: 60 %

No.	Mk	Freq.	Reading	Factor	Measurement	Limit	Over	Detector	Antenna Height	Table Degree	Comment
		MHz	dBuV	dBuV/m	dBuV/m	dBuV/m	dB		cm	degree	
1		2440.000	104.75	-9.64	95.11	114.00	-18.89	peak			
2		3933.333	49.92	-5.22	44.70	74.00	-29.30	peak			
3		4841.667	46.51	-2.21	44.30	74.00	-29.70	peak			
4	*	2440.000	92.60	-9.64	82.96	94.00	-11.04	AVG	100	343	

RESULT: PASS

RADIATED EMISSION TEST- (ABOVE 1GHZ)-MIDDLE CHANNEL- VERTICAL

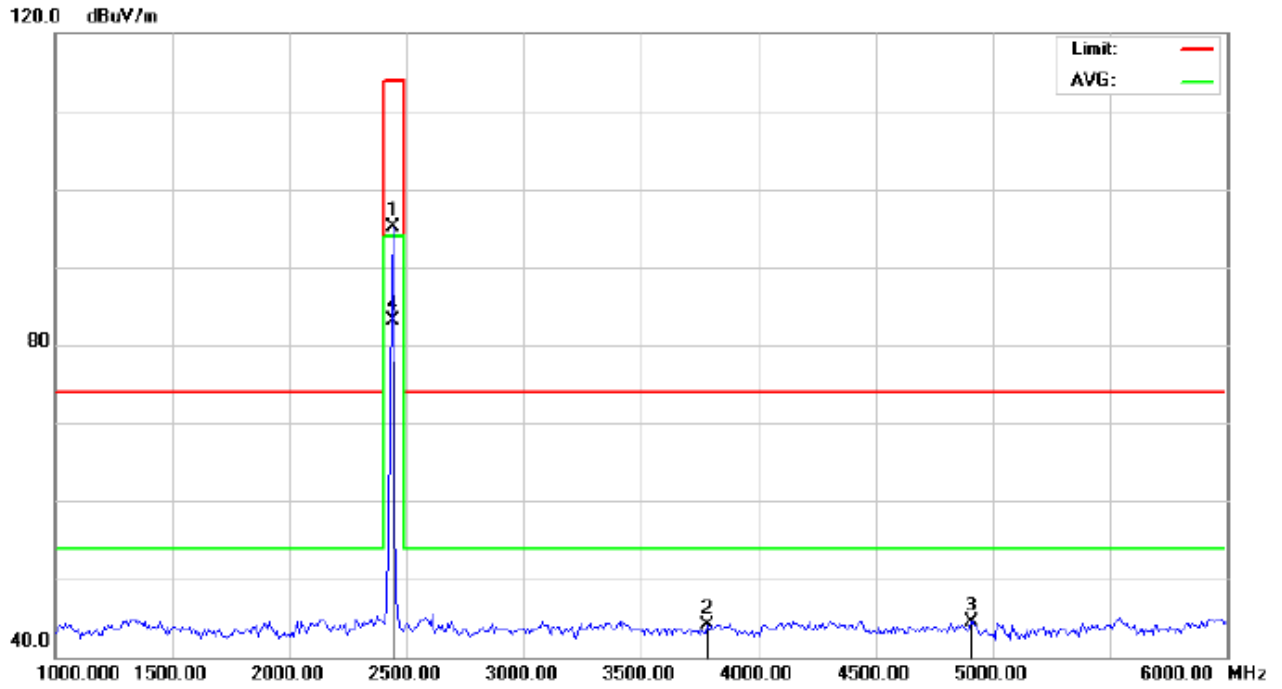

Site: site #1
Limit: FCC Class B 3M Radiation above 1GHZ(PK)-
EUT: Bluetooth Receiver
M/N: AU04
Mode: Middle Channel TX
Note:

Polarization: *Vertical*
Power:
Distance: 3m

Temperature: 26
Humidity: 60 %

No.	Mk	Freq.	Reading	Factor	Measurement	Limit	Over	Detector	Antenna Height	Table Degree	Comment
		MHz	dBuV	dBuV/m	dBuV/m	dBuV/m	dB		cm	degree	
1		2440.000	104.70	-9.64	95.06	114.00	-18.94	peak			
2		3783.333	50.33	-6.14	44.19	74.00	-29.81	peak			
3		4908.333	46.58	-2.04	44.54	74.00	-29.46	peak			
4	*	2440.000	92.83	-9.64	83.19	94.00	-10.81	AVG	100	117	

RESULT: PASS

RADIATED EMISSION TEST- (ABOVE 1GHZ)-HIGH CHANNEL-HORIZONTAL

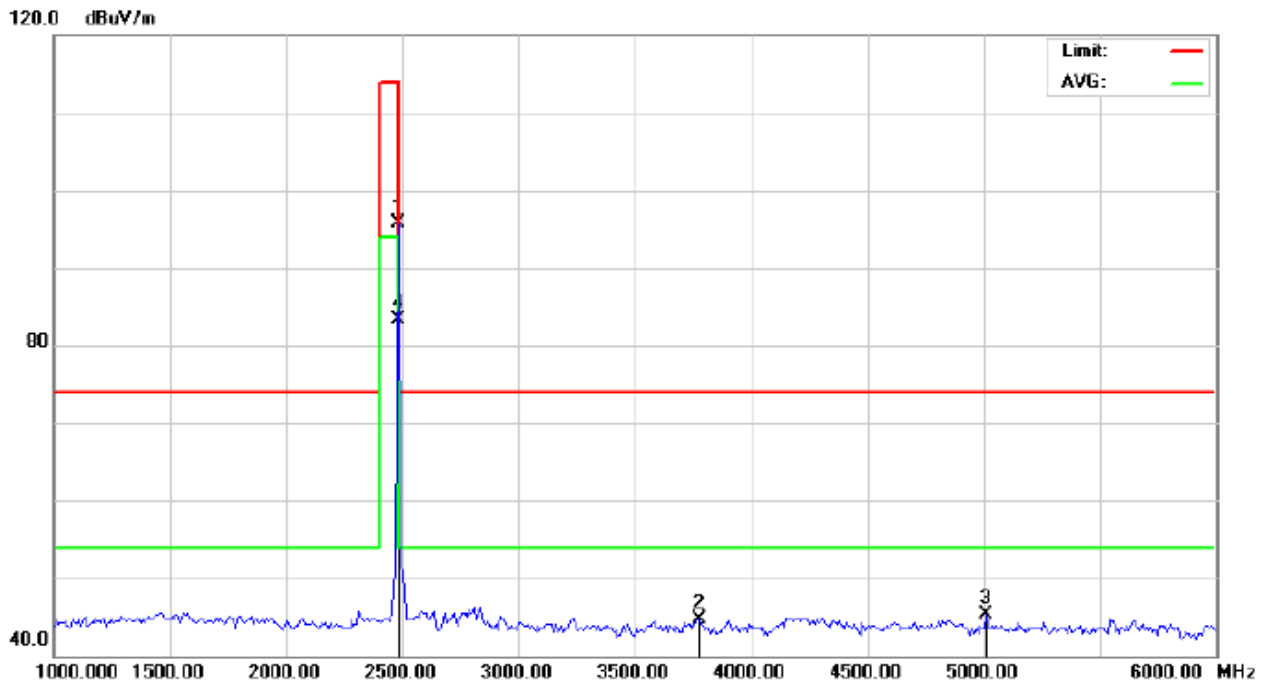

Site: site #1 Polarization: *Horizontal* Temperature: 26
 Limit: FCC Class B 3M Radiation above 1GHZ(PK)- Power: Humidity: 60 %
 EUT: Bluetooth Receiver Distance: 3m
 M/N: AU04
 Mode: High Channel TX
 Note:

No.	Mk	Freq.	Reading	Factor	Measurement	Limit	Over	Detector	Antenna Height	Table Degree	Comment
		MHz	dBuV	dBuV/m	dBuV/m	dBuV/m	dB		cm	degree	
1		2480.000	105.32	-9.59	95.73	114.00	-18.27	peak			
2		3775.000	50.99	-6.20	44.79	74.00	-29.21	peak			
3		5008.333	47.14	-1.80	45.34	74.00	-28.66	peak			
4	*	2480.000	92.81	-9.59	83.22	94.00	-10.78	AVG	100	347	

RESULT: PASS

RADIATED EMISSION TEST- (ABOVE 1GHZ)-HIGH CHANNEL- VERTICAL

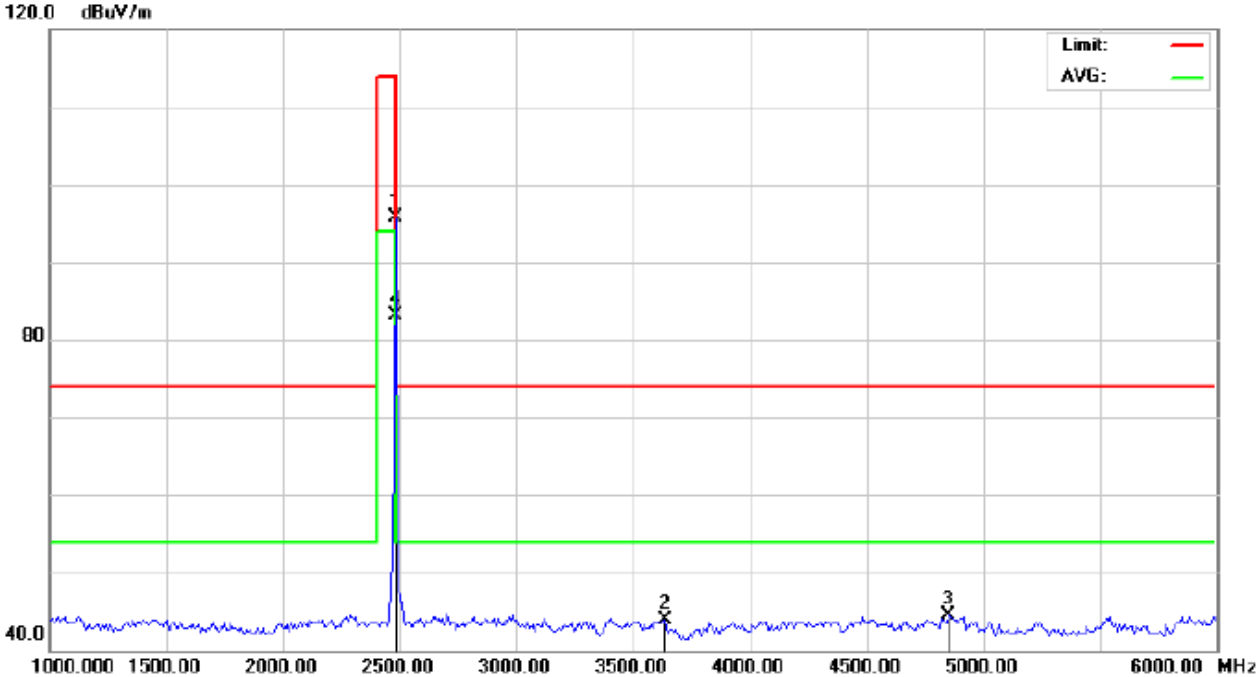

Site: site #1
 Limit: FCC Class B 3M Radiation above 1GHZ(PK)-
 EUT: Bluetooth Receiver
 M/N: AU04
 Mode: High Channel TX
 Note:

Polarization: **Vertical**
 Power:
 Distance: 3m

Temperature: 26
 Humidity: 60 %

No.	Mk	Freq.	Reading	Factor	Measurement	Limit	Over	Detector	Antenna Height	Table Degree	Comment
		MHz	dBuV	dBuV/m	dBuV/m	dBuV/m	dB		cm	degree	
1		2480.000	105.36	-9.59	95.77	114.00	-18.23	peak			
2		3633.333	50.89	-7.07	43.82	74.00	-30.18	peak			
3		4850.000	46.70	-2.19	44.51	74.00	-29.49	peak			
4	*	2480.000	92.76	-9.59	83.17	94.00	-10.83	AVG	100	115	

RESULT: PASS

Note: 6~25GHz at least have 20dB margin. No recording in the test report.
 Factor=Antenna Factor + Cable loss - Amplifier gain, Margin=Measurement-Limit.
 The ‘Factor’ value can be calculated automatically by software of measurement system.

Field strength of the fundamental signal

Peak value

Frequency	Reading Level	Factor	Measurement	Limit	Over	Antenna
(MHz)	(dBuv)	(dB/m)	(dBuv/m)	(dBuv/m)	(dB)	Polarization
2402	103.79	-9.68	94.11	114	-19.89	Horizontal
2402	102.75	-9.68	93.07	114	-20.93	Vertical
2440	104.75	-9.64	95.11	114	-18.89	Horizontal
2440	104.70	-9.64	95.06	114	-18.94	Vertical
2480	105.32	-9.59	95.73	114	-18.27	Horizontal
2480	105.36	-9.59	95.77	114	-18.23	Vertical

Average value

Frequency	Reading Level	Factor	Measurement	Limit	Over	Antenna
(MHz)	(dBuv)	(dB/m)	(dBuv/m)	(dBuv/m)	(dB)	Polarization
2402	93.40	-9.68	83.72	94	-10.28	Horizontal
2402	92.46	-9.68	82.78	94	-11.22	Vertical
2440	92.60	-9.64	82.96	94	-11.04	Horizontal
2440	92.83	-9.64	83.19	94	-10.81	Vertical
2480	92.81	-9.59	83.22	94	-10.78	Horizontal
2480	92.76	-9.59	83.17	94	-10.83	Vertical

9. BAND EDGE EMISSION

9.1. MEASUREMENT PROCEDURE

1The EUT operates at hopping-off test mode. The lowest or highest channels are tested to verify the largest transmission and spurious emissions power at the continuous transmission mode.

2Max hold the trace of the setp 1,and the EUT operates at hopping-on test mode to verify the largest spurious emissions power.

3Set the spectrum analyzer in the following setting in order to capture the lower and upper band-edges of the emission: (a) PEAK: RBW=VBW=1.5MHz / Sweep=AUTO

9.2 TEST SETUP

RADIATED EMISSION TEST SETUP

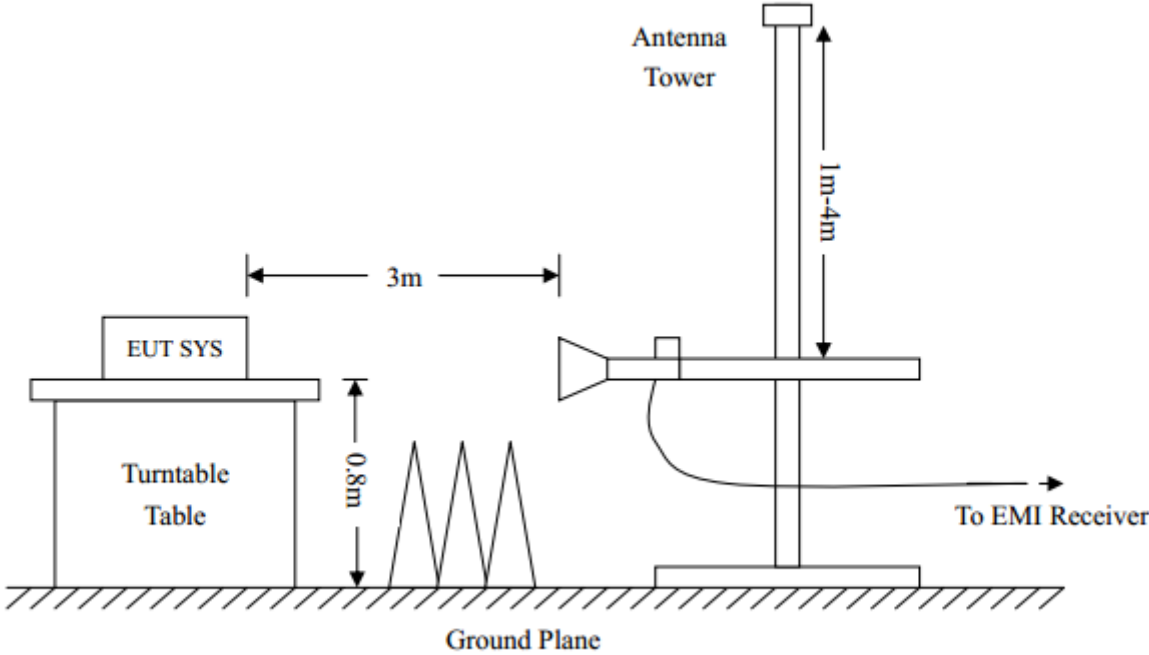

9.3 RADIATED TEST RESULT

(Worst modulation:GFSK)

FOR BR/EDR

TEST PLOT OF BAND EDGE FOR LOW CHANNEL-Horizontal

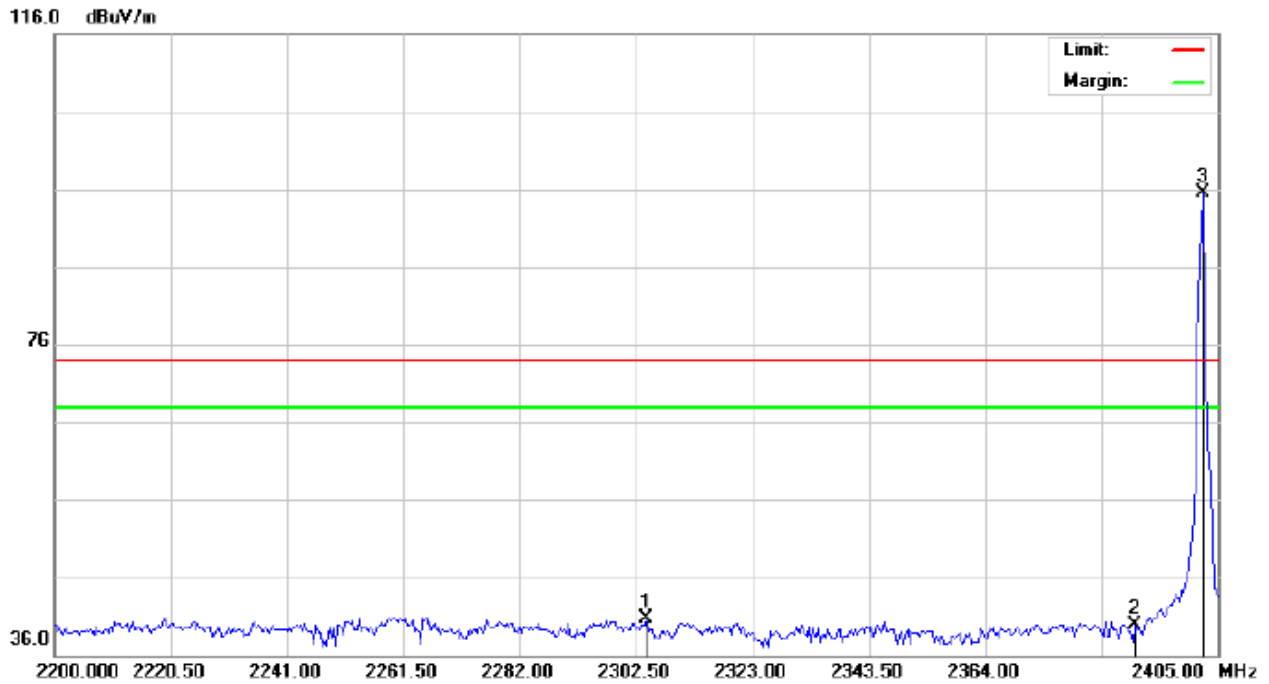

Site: site #1	Polarization: <i>Horizontal</i>	Temperature: 26
Limit: FCC Class B 3M Radiation above 1GHZ(PK)	Power:	Humidity: 60 %
EUT: Bluetooth Receiver	Distance:	
M/N: AU04		
Mode: Low Channel TX		
Note:		

No.	Mk	Freq.	Reading	Factor	Measurement	Limit	Over	Detector	Antenna Height	Table Degree	Comment
		MHz	dBuV	dBuV/m	dBuV/m	dBuV/m	dB		cm	degree	
1		2304.208	30.44	10.21	40.65	74.00	-33.35	peak			
2		2390.000	29.50	10.31	39.81	74.00	-34.19	peak			
3	*	2402.000	85.22	10.32	95.54	74.00	21.54	peak			

TEST PLOT OF BAND EDGE FOR LOW CHANNEL -Vertical

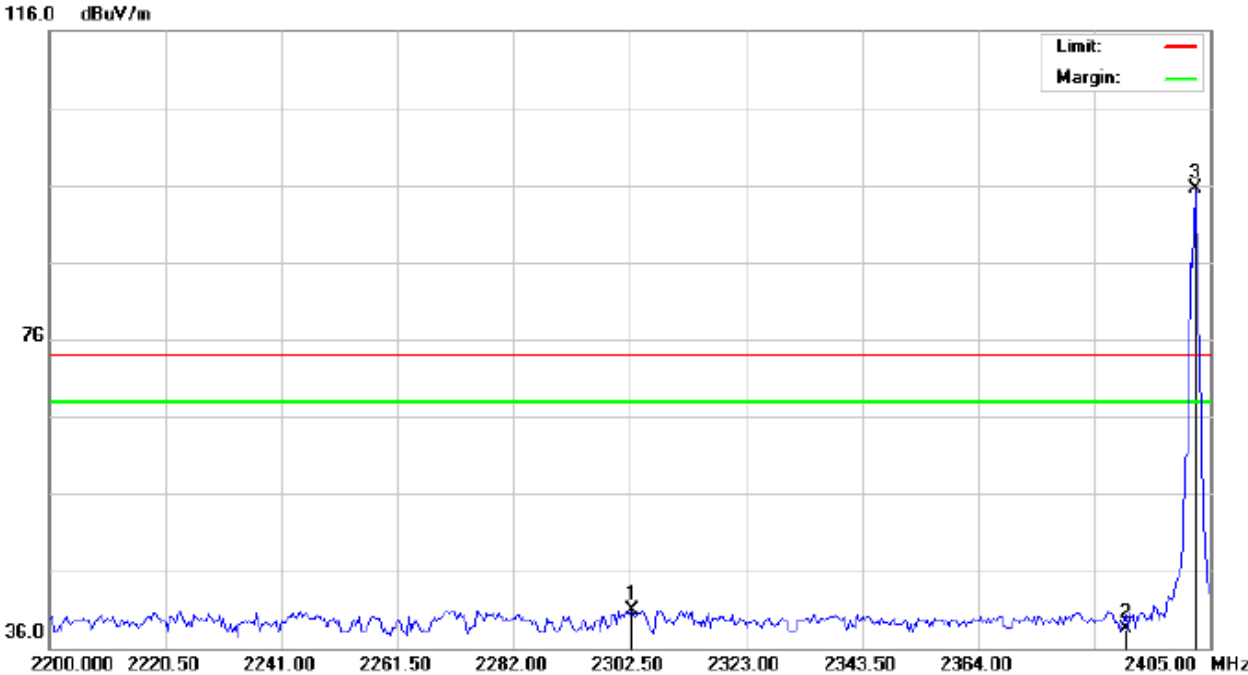

Site: site #1 Polarization: *Vertical* Temperature: 26
 Limit: FCC Class B 3M Radiation above 1GHZ(PK) Power: Humidity: 60 %
 EUT: Bluetooth Receiver Distance:
 M/N: AU04
 Mode: Low Channel TX
 Note:

No.	Mk	Freq.	Reading	Factor	Measurement	Limit	Over	Detector	Antenna Height	Table Degree	Comment
		MHz	dBuV	dBuV/m	dBuV/m	dBuV/m	dB		cm	degree	
1		2302.842	30.68	10.21	40.89	74.00	-33.11	peak			
2		2390.000	28.21	10.31	38.52	74.00	-35.48	peak			
3	*	2402.000	85.09	10.32	95.41	74.00	21.41	peak			

TEST PLOT OF BAND EDGE FOR HIGH CHANNEL -Horizontal

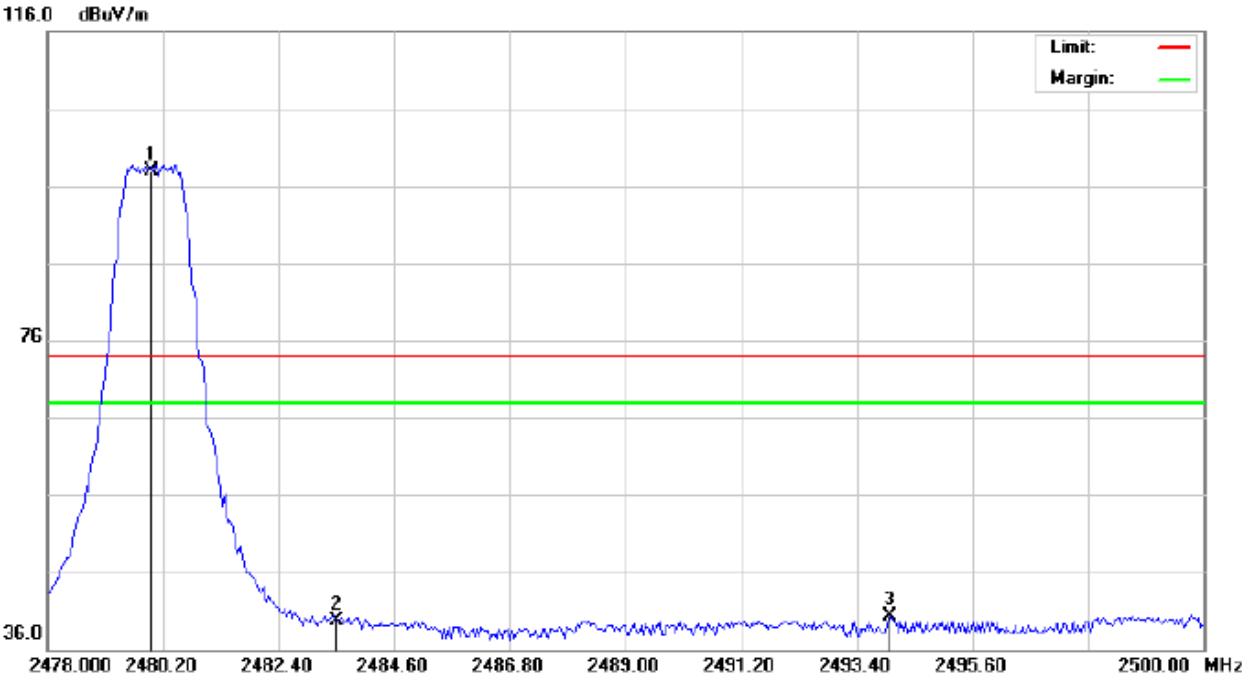

Site: site #1 Polarization: *Horizontal* Temperature: 26
 Limit: FCC Class B 3M Radiation above 1GHZ(PK) Power: Humidity: 60 %
 EUT: Bluetooth Receiver Distance:
 M/N: AU04
 Mode: High Channel TX
 Note:

No.	Mk	Freq.	Reading	Factor	Measurement	Limit	Over	Detector	Antenna Height	Table Degree	Comment
		MHz	dBuV	dBuV/m	dBuV/m	dBuV/m	dB		cm	degree	
1	*	2480.000	87.55	10.41	97.96	74.00	23.96	peak			
2		2483.500	29.19	10.41	39.60	74.00	-34.40	peak			
3		2494.023	29.85	10.42	40.27	74.00	-33.73	peak			

TEST PLOT OF BAND EDGE FOR HIGH CHANNEL-Vertical

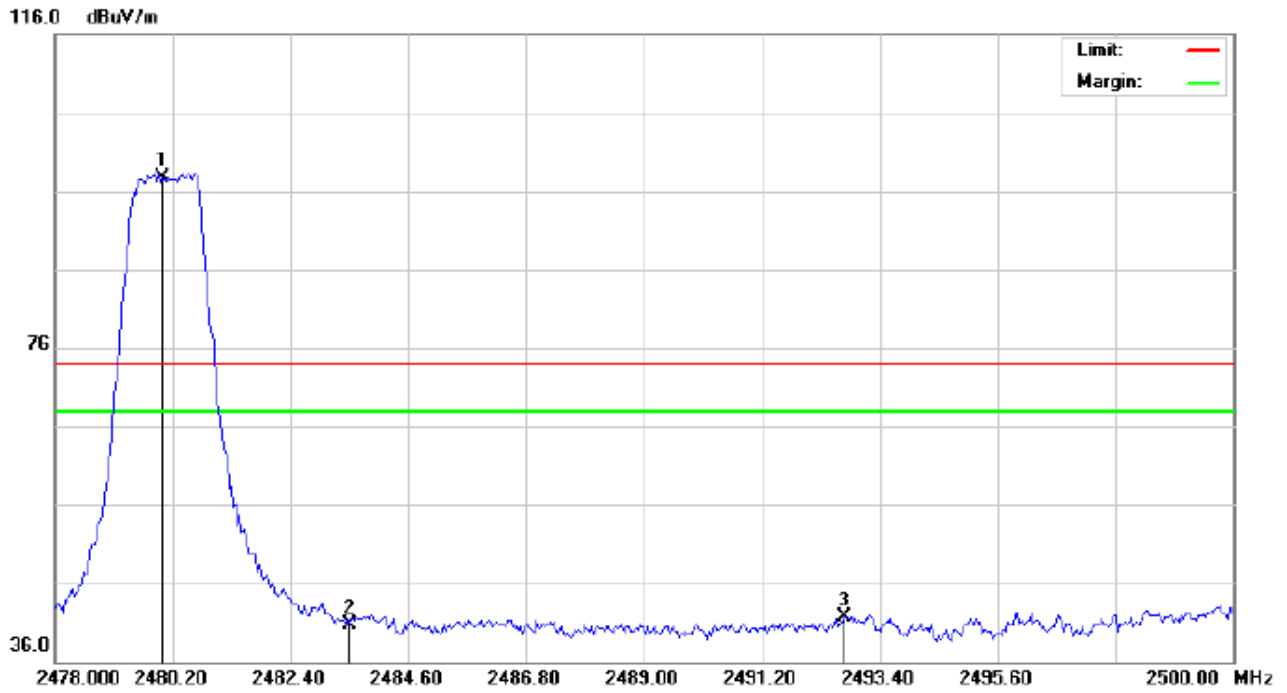

Site: site #1 Polarization: *Vertical* Temperature: 26
 Limit: FCC Class B 3M Radiation above 1GHZ(PK) Power: Humidity: 60 %
 EUT: Bluetooth Receiver Distance:
 M/N: AU04
 Mode: High Channel TX
 Note:

No.	Mk	Freq.	Reading	Factor	Measurement	Limit	Over	Detector	Antenna Height	Table Degree	Comment
		MHz	dBuV	dBuV/m	dBuV/m	dBuV/m	dB		cm	degree	
1	*	2480.000	87.32	10.41	97.73	74.00	23.73	peak			
2		2483.500	30.26	10.41	40.67	74.00	-33.33	peak			
3		2492.740	31.21	10.42	41.63	74.00	-32.37	peak			

RESULT: PASS

Note: The other modes radiation emission have enough 20dB margin.

Factor=Antenna Factor + Cable loss - Amplifier gain, Over=Measure-Limit.

The "Factor" value can be calculated automatically by software of measurement system.

Hopping on mode and Hopping off mode have been tested, but only worst case reported.

FOR BLE

TEST PLOT OF BAND EDGE FOR LOW CHANNEL-Horizontal

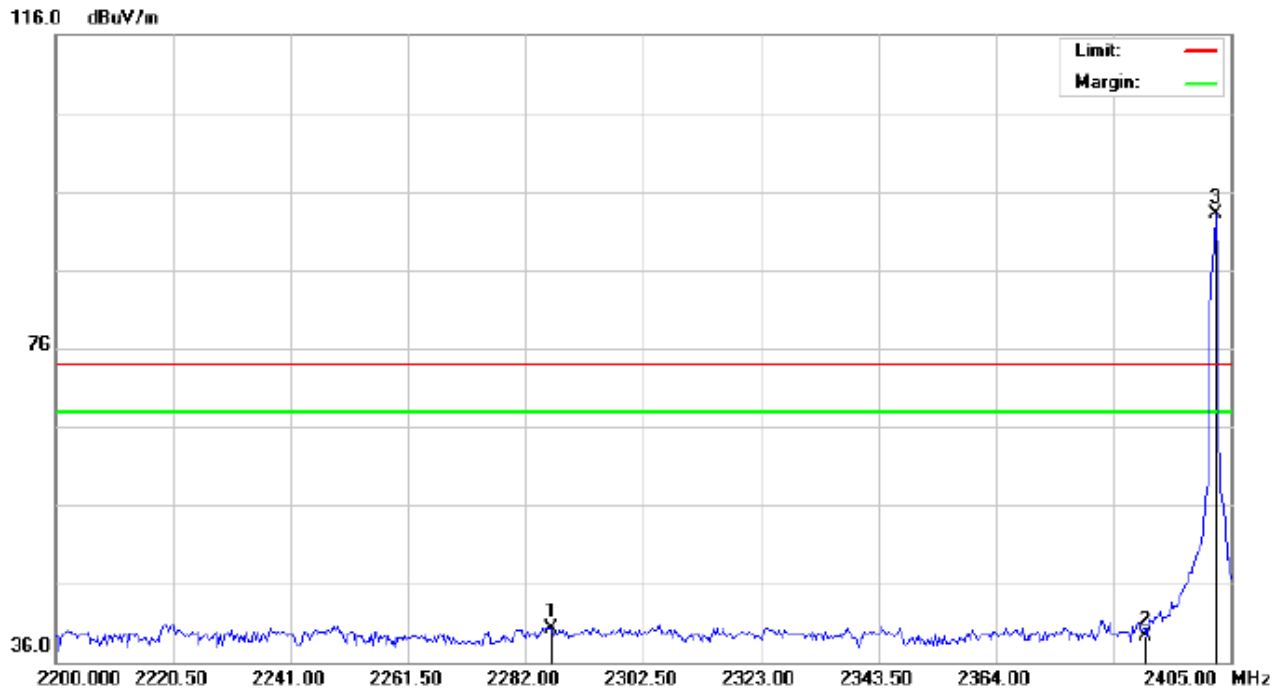

Site: site #1
Limit: FCC Class B 3M Radiation above 1GHZ(PK)
EUT: Bluetooth Receiver
M/N: AU04
Mode: Low Channel TX
Note:

Polarization: *Horizontal*
Power:
Distance:

Temperature: 26
Humidity: 60 %

No.	Mk	Freq.	Reading	Factor	Measurement	Limit	Over	Detector	Antenna Height	Table Degree	Comment
		MHz	dBuV	dBuV/m	dBuV/m	dBuV/m	dB		cm	degree	
1		2286.442	30.15	10.19	40.34	74.00	-33.66	peak			
2		2390.000	29.00	10.31	39.31	74.00	-34.69	peak			
3	*	2402.000	82.72	10.32	93.04	74.00	19.04	peak			

TEST PLOT OF BAND EDGE FOR LOW CHANNEL -Vertical

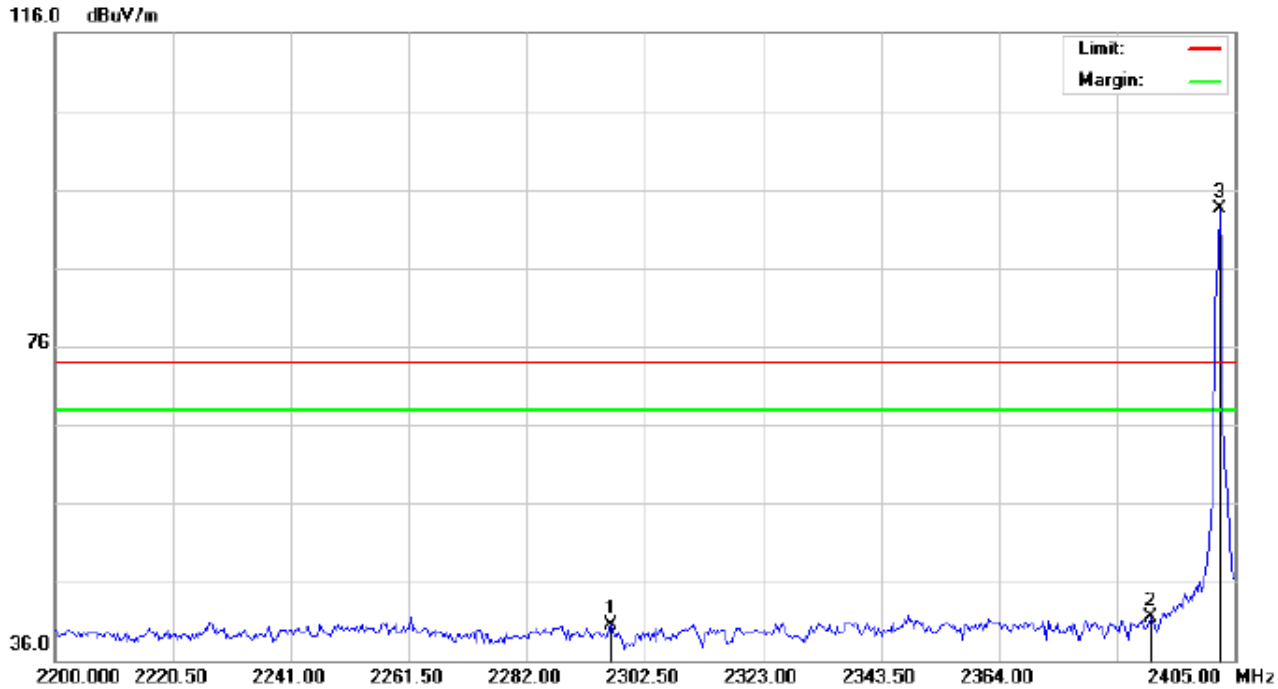

Site: site #1 Polarization: *Vertical* Temperature: 26
 Limit: FCC Class B 3M Radiation above 1GHZ(PK) Power: Humidity: 60 %
 EUT: Bluetooth Receiver Distance:
 M/N: AU04
 Mode: Low Channel TX
 Note:

No.	Mk	Freq.	Reading	Factor	Measurement	Limit	Over	Detector	Antenna Height	Table Degree	Comment
		MHz	dBuV	dBuV/m	dBuV/m	dBuV/m	dB		cm	degree	
1		2296.692	30.22	10.21	40.43	74.00	-33.57	peak			
2		2390.000	31.21	10.31	41.52	74.00	-32.48	peak			
3	*	2402.000	83.09	10.32	93.41	74.00	19.41	peak			

TEST PLOT OF BAND EDGE FOR HIGH CHANNEL -Horizontal

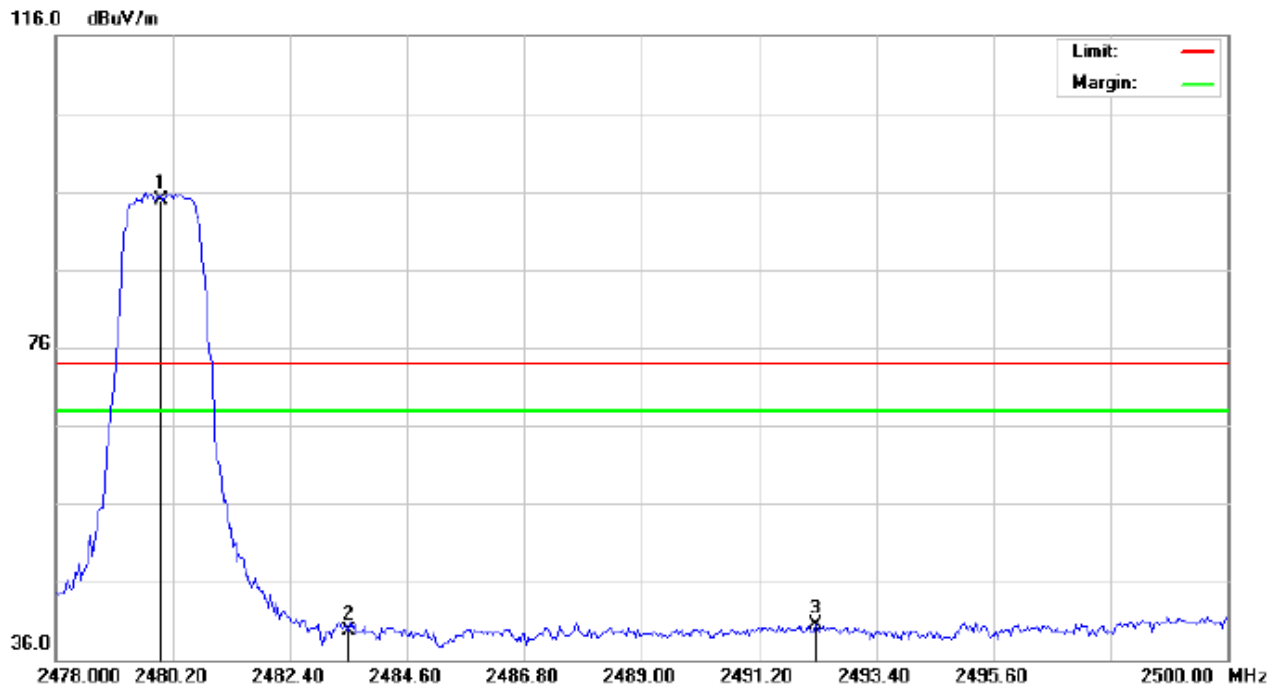

Site: site #1	Polarization: <i>Horizontal</i>	Temperature: 26
Limit: FCC Class B 3M Radiation above 1GHZ(PK)	Power:	Humidity: 60 %
EUT: Bluetooth Receiver	Distance:	
M/N: AU04		
Mode: High Channel TX		
Note:		

No.	Mk	Freq.	Reading	Factor	Measurement	Limit	Over	Detector	Antenna Height	Table Degree	Comment
		MHz	dBuV	dBuV/m	dBuV/m	dBuV/m	dB		cm	degree	
1	*	2480.000	84.55	10.41	94.96	74.00	20.96	peak			
2		2483.500	29.19	10.41	39.60	74.00	-34.40	peak			
3		2492.263	29.99	10.42	40.41	74.00	-33.59	peak			

TEST PLOT OF BAND EDGE FOR HIGH CHANNEL-Vertical

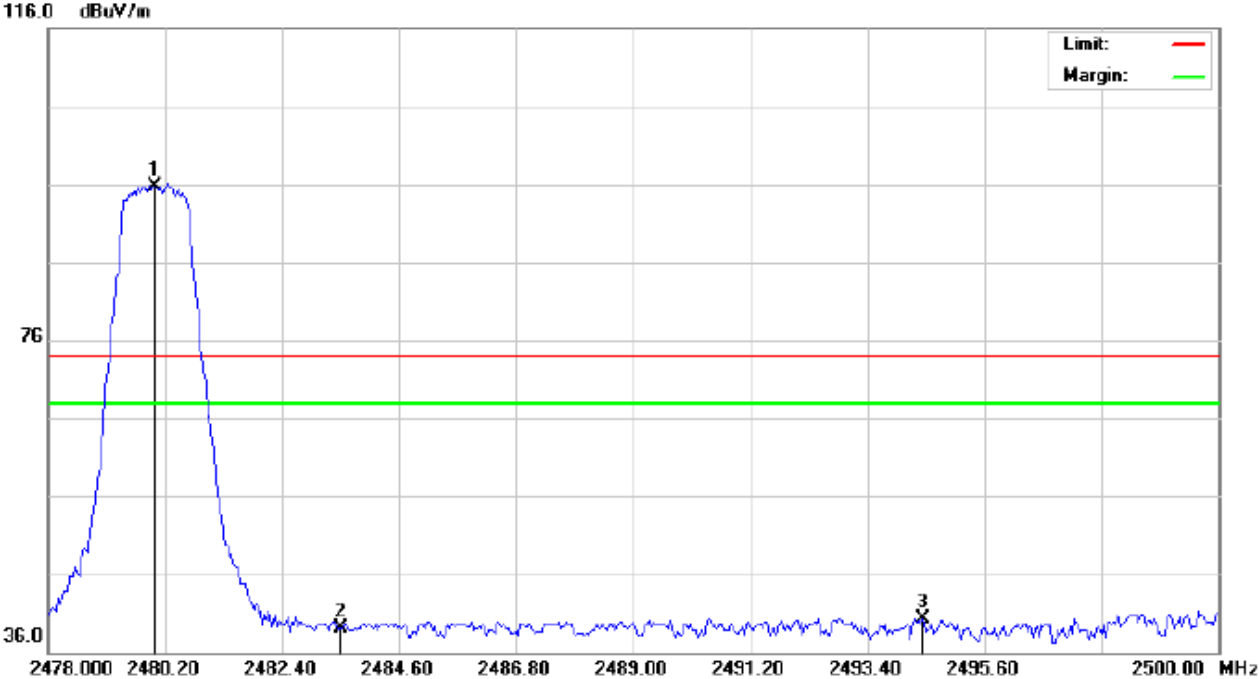

Site: site #1 Polarization: *Vertical* Temperature: 26
 Limit: FCC Class B 3M Radiation above 1GHZ(PK) Power: Humidity: 60 %
 EUT: Bluetooth Receiver Distance:
 M/N: AU04
 Mode: High Channel TX
 Note:

No.	Mk	Freq.	Reading	Factor	Measurement	Limit	Over	Detector	Antenna Height	Table Degree	Comment
		MHz	dBuV	dBuV/m	dBuV/m	dBuV/m	dB		cm	degree	
1	*	2480.000	85.32	10.41	95.73	74.00	21.73	peak			
2		2483.500	28.76	10.41	39.17	74.00	-34.83	peak			
3		2494.427	29.94	10.42	40.36	74.00	-33.64	peak			

RESULT: PASS

Note: The other modes radiation emission have enough 20dB margin.
 Factor=Antenna Factor + Cable loss - Amplifier gain, Over=Measure-Limit.
 The "Factor" value can be calculated automatically by software of measurement system.

10. 20DB BANDWIDTH

10.1. MEASUREMENT PROCEDURE

1. Connect EUT RF output port to the Spectrum Analyzer through an RF attenuator
2. Set the EUT Work on the top, the middle and the bottom operation frequency individually.
3. Set Span = approximately 2 to 3 times the 20 dB bandwidth, centered on a hopping channel
 $RBW \geq 1\%$ of the 20 dB bandwidth, $VBW \geq RBW$; Sweep = auto; Detector function = peak
4. Set SPA Trace 1 Max hold, then View.

10.2. TEST SET-UP

(BLOCK DIAGRAM OF CONFIGURATION)

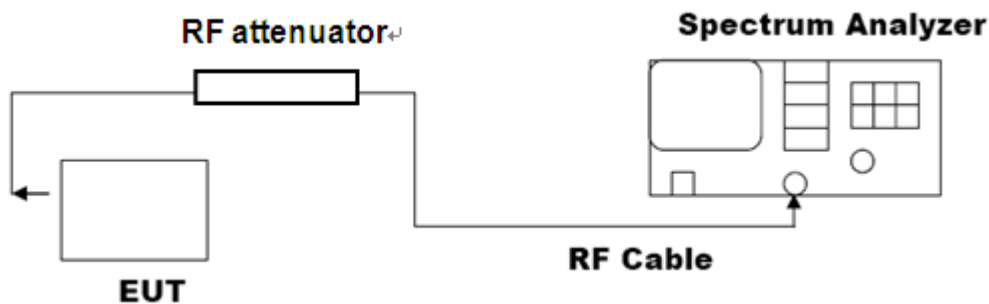

Note: The EUT has been used temporary antenna connector for testing.

10.3. LIMITS AND MEASUREMENT RESULTS

FOR BR/EDR

BLUETOOTH 1MBPS LIMITS AND MEASUREMENT RESULT			
Applicable Limits	Measurement Result		
	Test Data (MHz)		Criteria
N/A	Low Channel	1.103	PASS
	Middle Channel	1.104	PASS
	High Channel	1.081	PASS

TEST PLOT OF BANDWIDTH FOR LOW CHANNEL

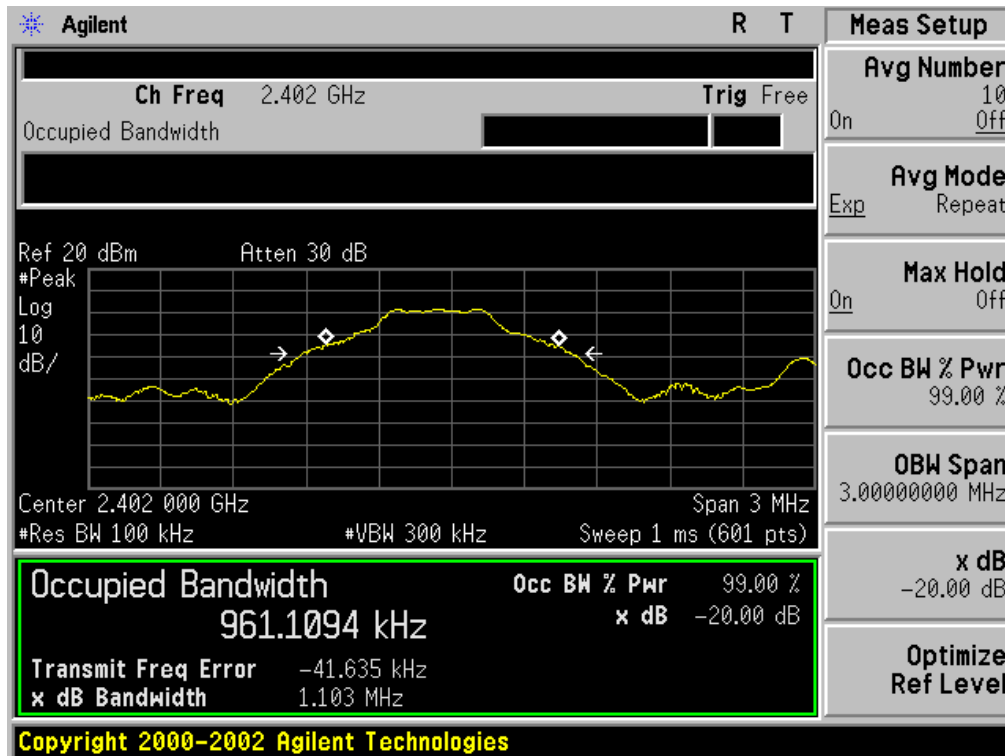

TEST PLOT OF BANDWIDTH FOR MIDDLE CHANNEL

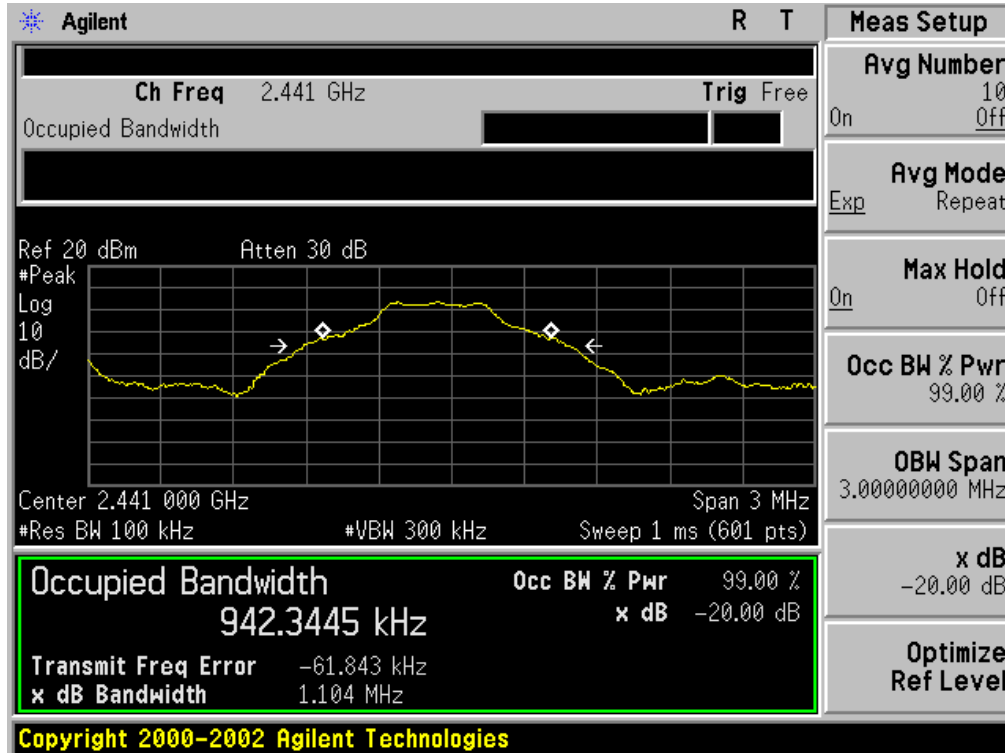

TEST PLOT OF BANDWIDTH FOR HIGH CHANNEL

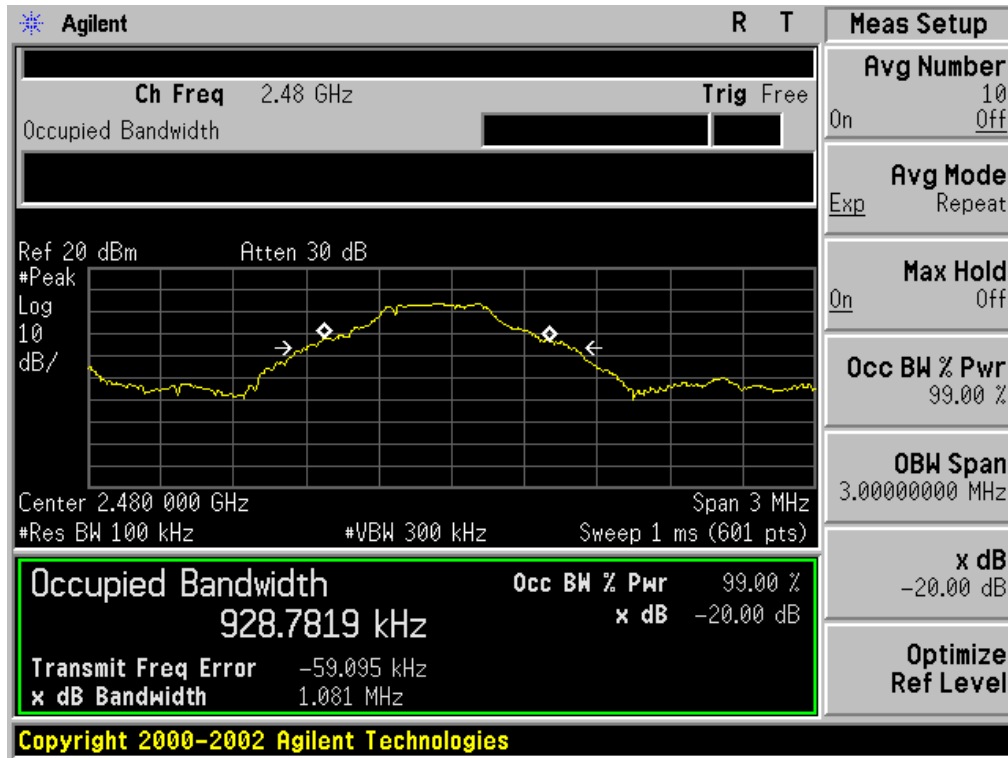

BLUETOOTH 2Mbps LIMITS AND MEASUREMENT RESULT			
Applicable Limits	Measurement Result		
	Test Data (MHz)		Criteria
N/A	Low Channel	1.360	PASS
	Middle Channel	1.375	PASS
	High Channel	1.358	PASS

TEST PLOT OF BANDWIDTH FOR LOW CHANNEL

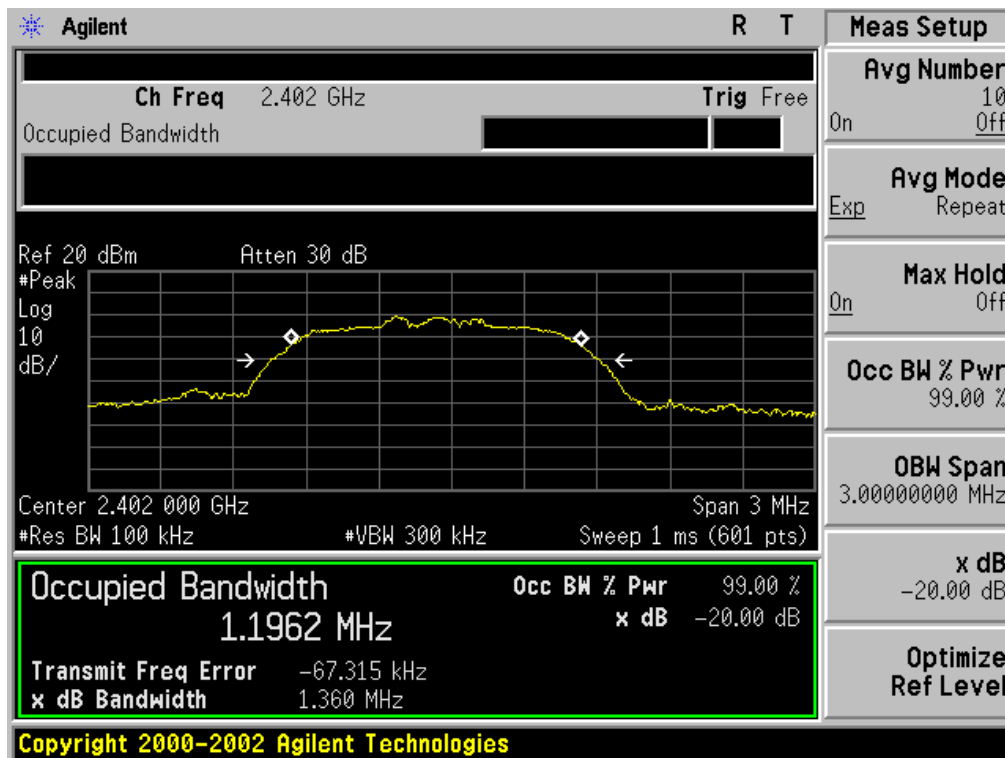

TEST PLOT OF BANDWIDTH FOR MIDDLE CHANNEL

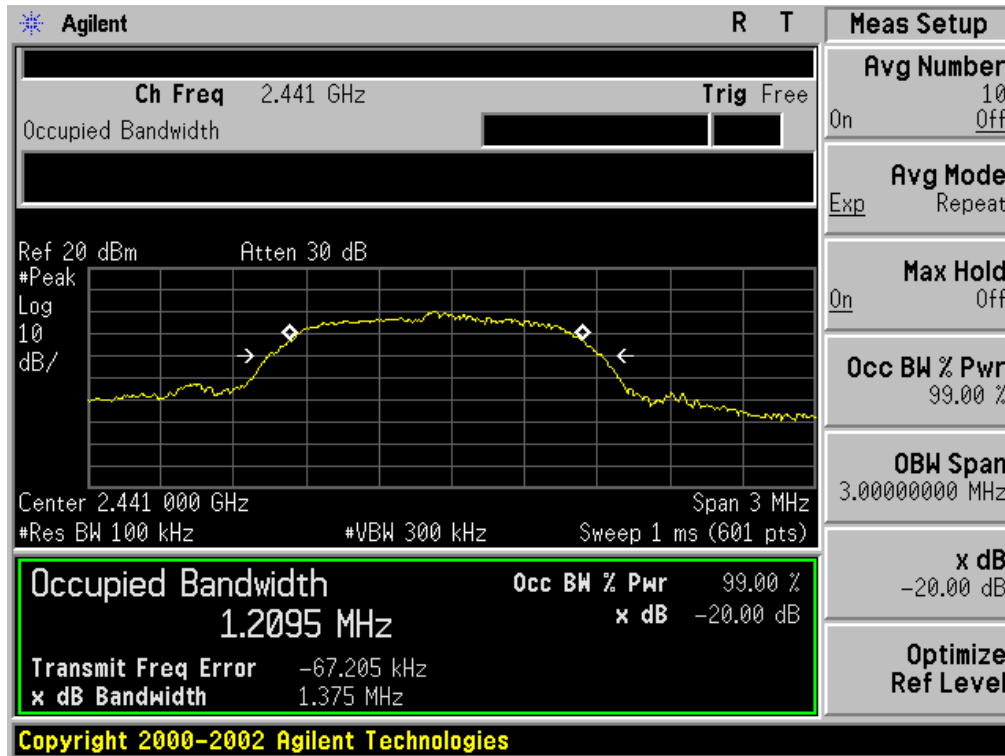

TEST PLOT OF BANDWIDTH FOR HIGH CHANNEL

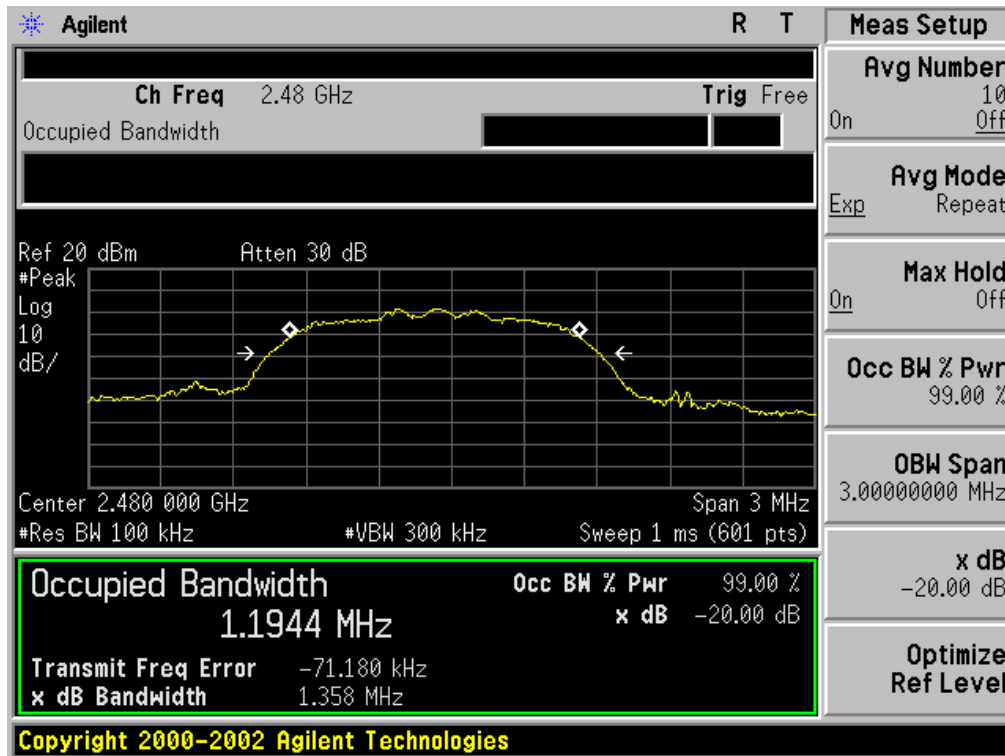

BLUETOOTH 3MBPS LIMITS AND MEASUREMENT RESULT			
Applicable Limits	Measurement Result		
	Test Data (MHz)		Criteria
N/A	Low Channel	1.360	PASS
	Middle Channel	1.361	PASS
	High Channel	1.367	PASS

TEST PLOT OF BANDWIDTH FOR LOW CHANNEL

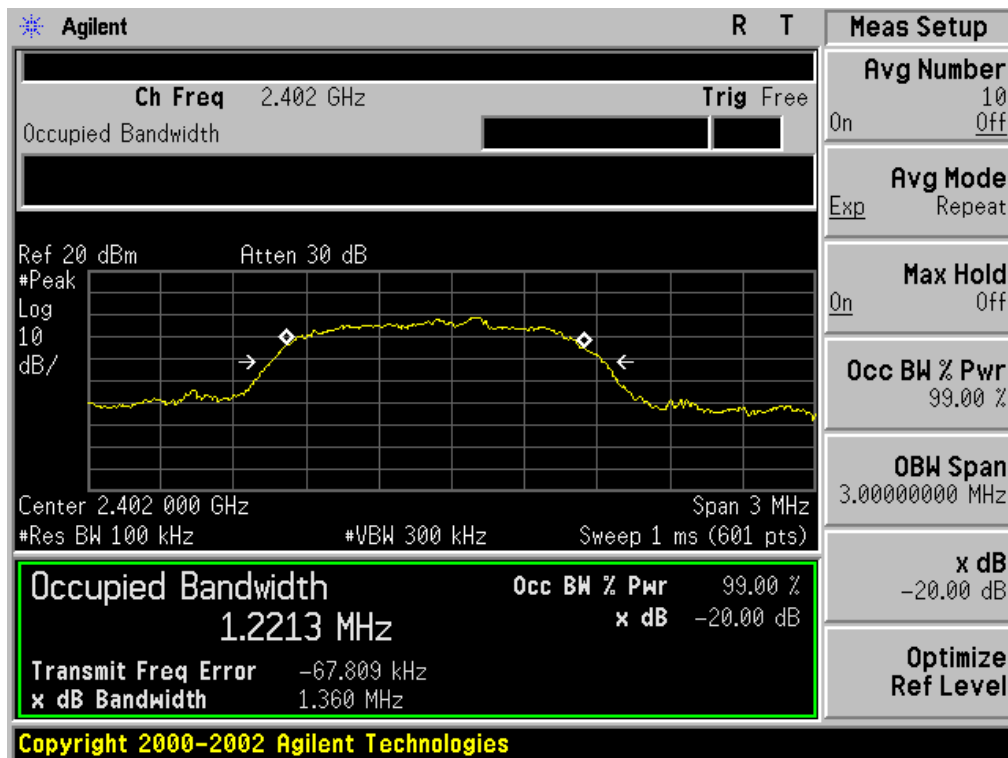

TEST PLOT OF BANDWIDTH FOR MIDDLE CHANNEL

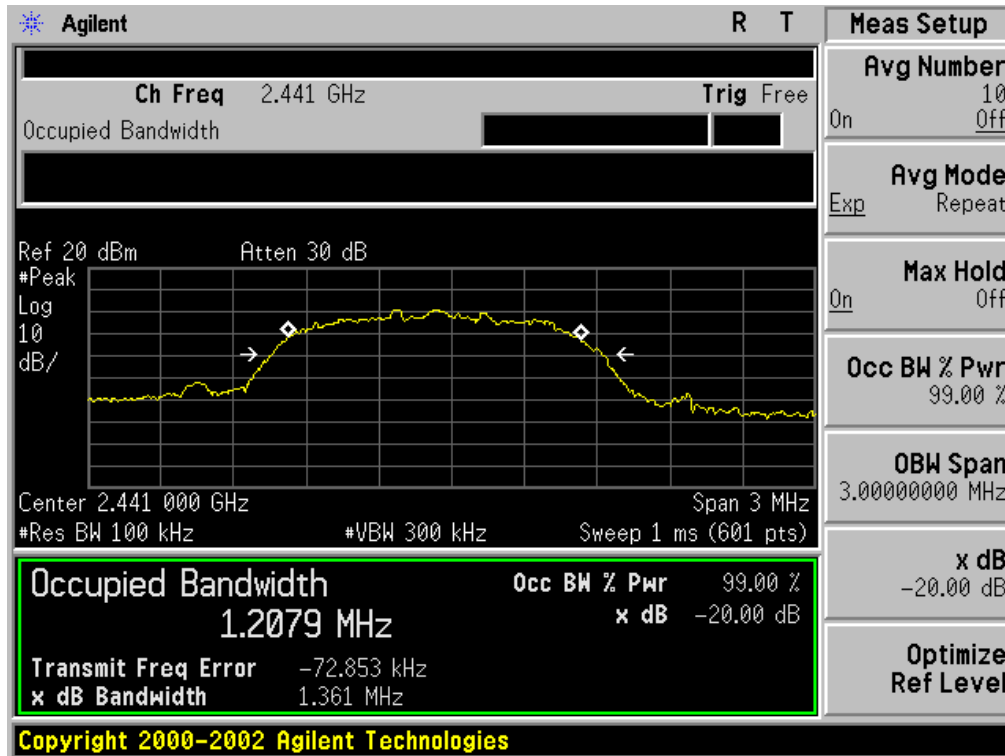

TEST PLOT OF BANDWIDTH FOR HIGH CHANNEL

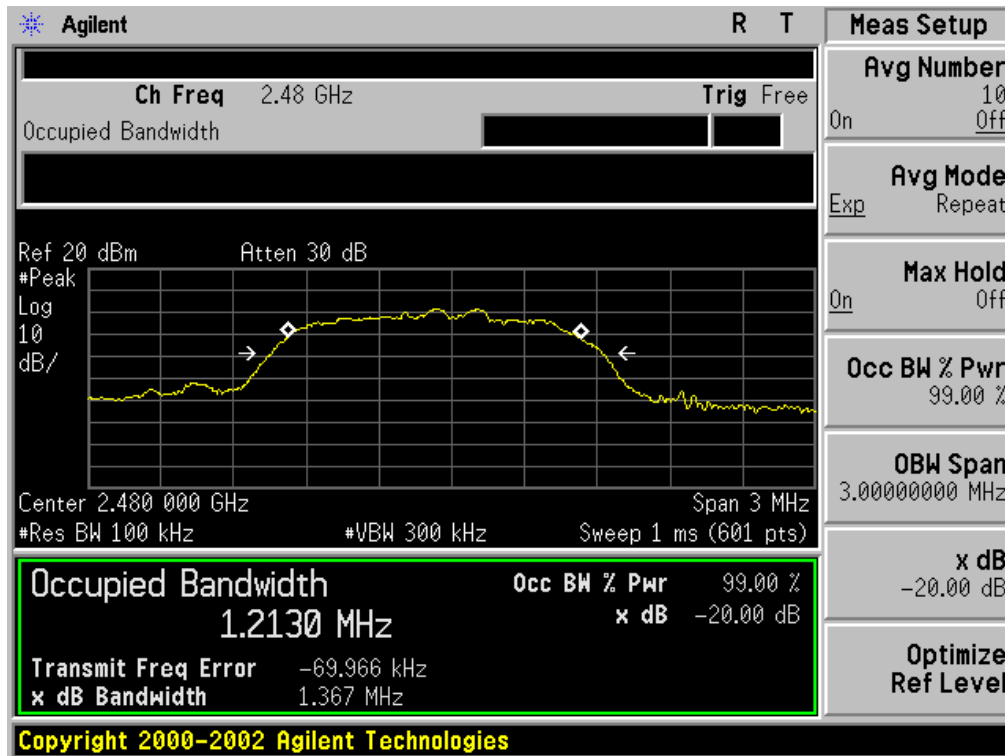

FOR BLE

BLUETOOTH 1MBPS LIMITS AND MEASUREMENT RESULT			
Applicable Limits	Measurement Result		
	Test Data (MHz)		Criteria
N/A	Low Channel	1.202	PASS
	Middle Channel	1.202	PASS
	High Channel	1.202	PASS

TEST PLOT OF BANDWIDTH FOR LOW CHANNEL

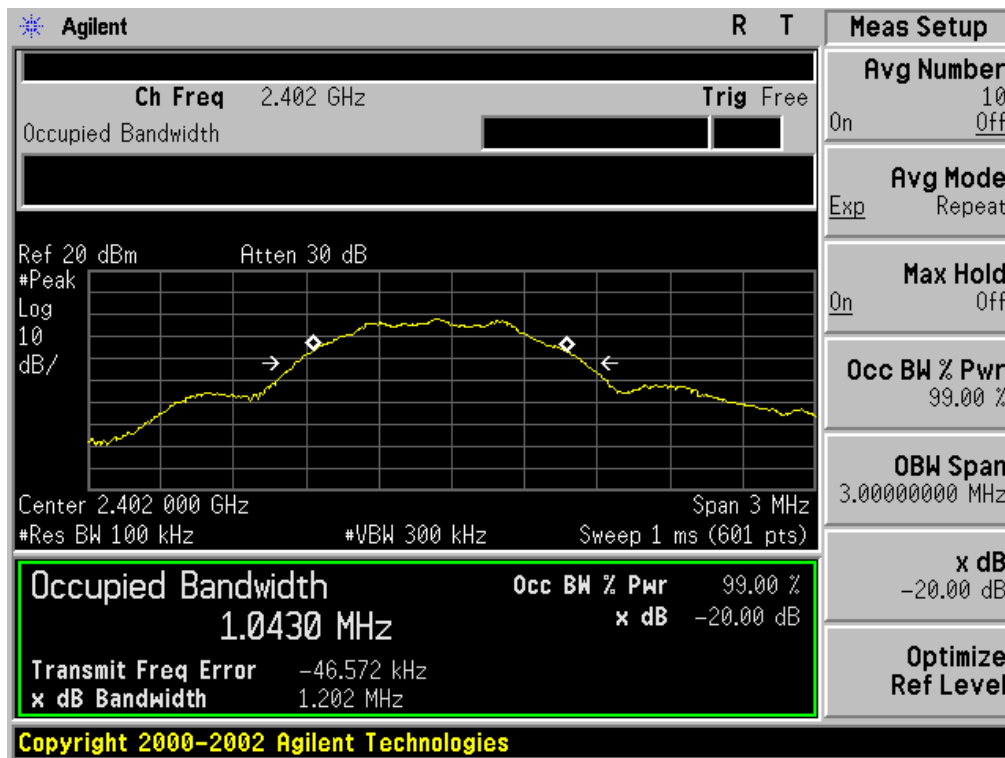

TEST PLOT OF BANDWIDTH FOR MIDDLE CHANNEL

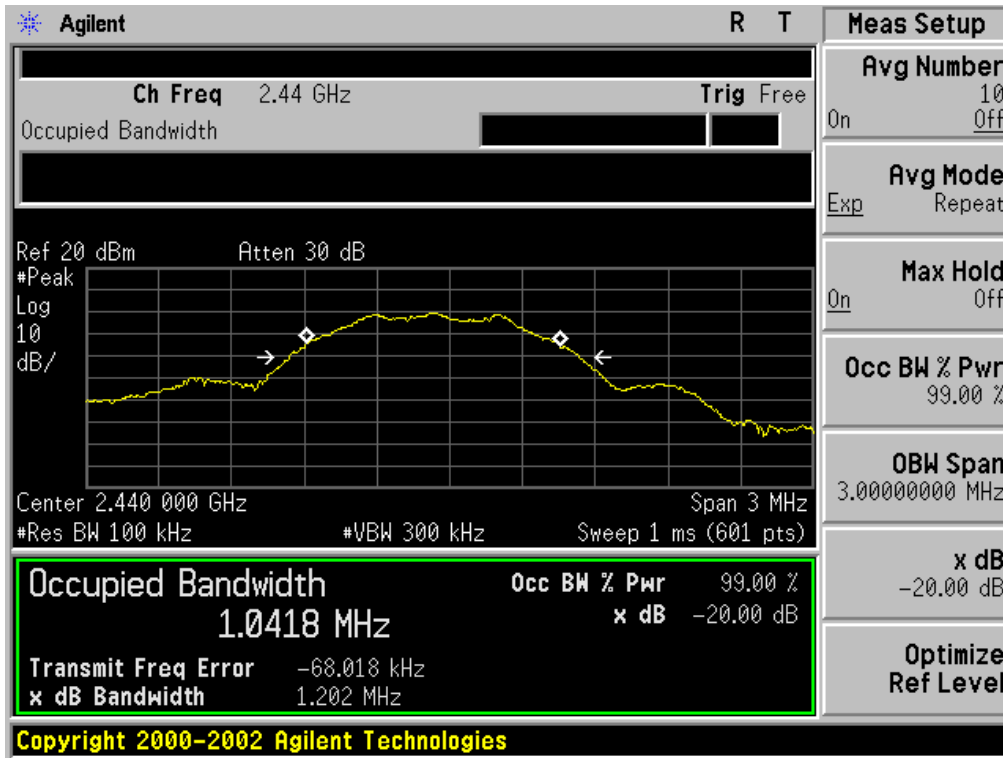

TEST PLOT OF BANDWIDTH FOR HIGH CHANNEL

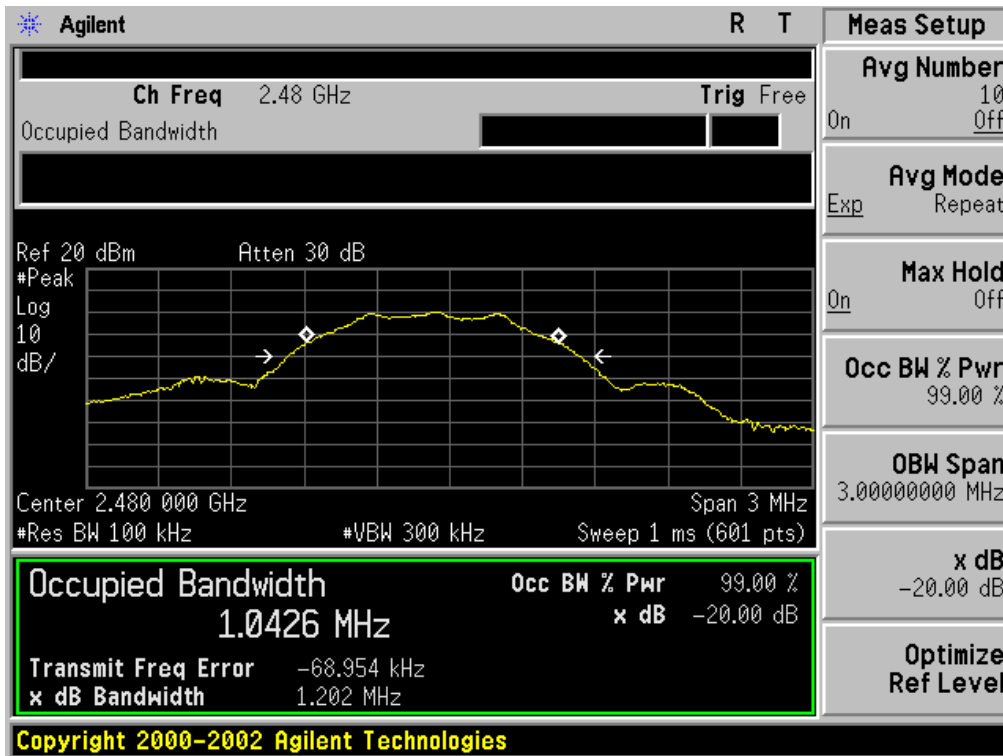

11. FCC LINE CONDUCTED EMISSION TEST

11.1. LIMITS OF LINE CONDUCTED EMISSION TEST

Frequency	Maximum RF Line Voltage	
	Q.P.(dBuV)	Average(dBuV)
150kHz~500kHz	66-56	56-46
500kHz~5MHz	56	46
5MHz~30MHz	60	50

Note:

1. The lower limit shall apply at the transition frequency.
2. The limit decreases linearly with the logarithm of the frequency in the range 0.15 MHz to 0.50 MHz.

11.2. BLOCK DIAGRAM OF LINE CONDUCTED EMISSION TEST

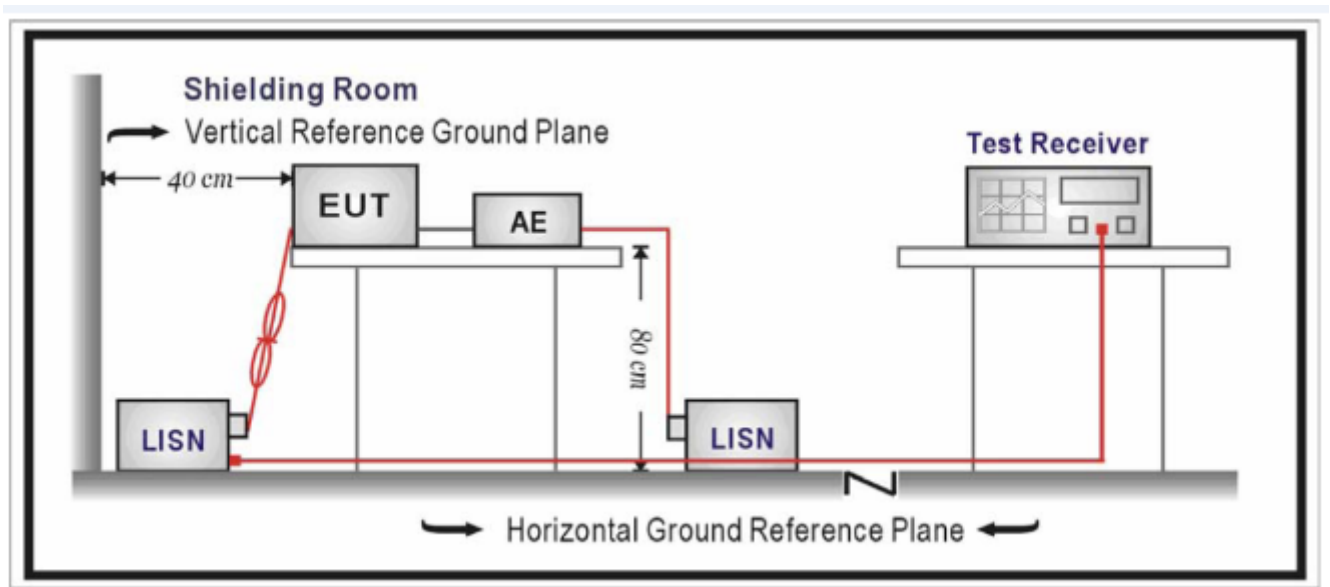

11.3. PRELIMINARY PROCEDURE OF LINE CONDUCTED EMISSION TEST

1. The equipment was set up as per the test configuration to simulate typical actual usage per the user's manual. When the EUT is a tabletop system, a wooden table with a height of 0.8 meters is used and is placed on the ground plane as per ANSI C63.4 (see Test Facility for the dimensions of the ground plane used). When the EUT is a floor-standing equipment, it is placed on the ground plane which has a 3-12 mm non-conductive covering to insulate the EUT from the ground plane.
2. Support equipment, if needed, was placed as per ANSI C63.4.
3. All I/O cables were positioned to simulate typical actual usage as per ANSI C63.4.
4. All support equipments received AC120V/60Hz power from a LISN, if any.
5. The EUT received DC charging voltage by PC which received 120V/60Hz power by a LISN.
6. The test program was started. Emissions were measured on each current carrying line of the EUT using a spectrum Analyzer / Receiver connected to the LISN powering the EUT. The LISN has two monitoring points: Line 1 (Hot Side) and Line 2 (Neutral Side). Two scans were taken: one with Line 1 connected to Analyzer / Receiver and Line 2 connected to a 50 ohm load; the second scan had Line 1 connected to a 50 ohm load and Line 2 connected to the Analyzer / Receiver.
7. Analyzer / Receiver scanned from 150 kHz to 30MHz for emissions in each of the test modes.
8. During the above scans, the emissions were maximized by cable manipulation.
9. The test mode(s) were scanned during the preliminary test.

Then, the EUT configuration and cable configuration of the above highest emission level were recorded for reference of final testing.

11.4. FINAL PROCEDURE OF LINE CONDUCTED EMISSION TEST

- EUT and support equipment was set up on the test bench as per step 2 of the preliminary test.
2. A scan was taken on both power lines, Line 1 and Line 2, recording at least the six highest emissions. Emission frequency and amplitude were recorded into a computer in which correction factors were used to calculate the emission level and compare reading to the applicable limit. If EUT emission level was less -2dB to the A.V. limit in Peak mode, then the emission signal was re-checked using Q.P and Average detector.
3. The test data of the worst case condition(s) was reported on the Summary Data page.

**11.5. TEST RESULT OF LINE CONDUCTED EMISSION TEST
FOR BR/EDR**

Line Conducted Emission Test Line 1-L

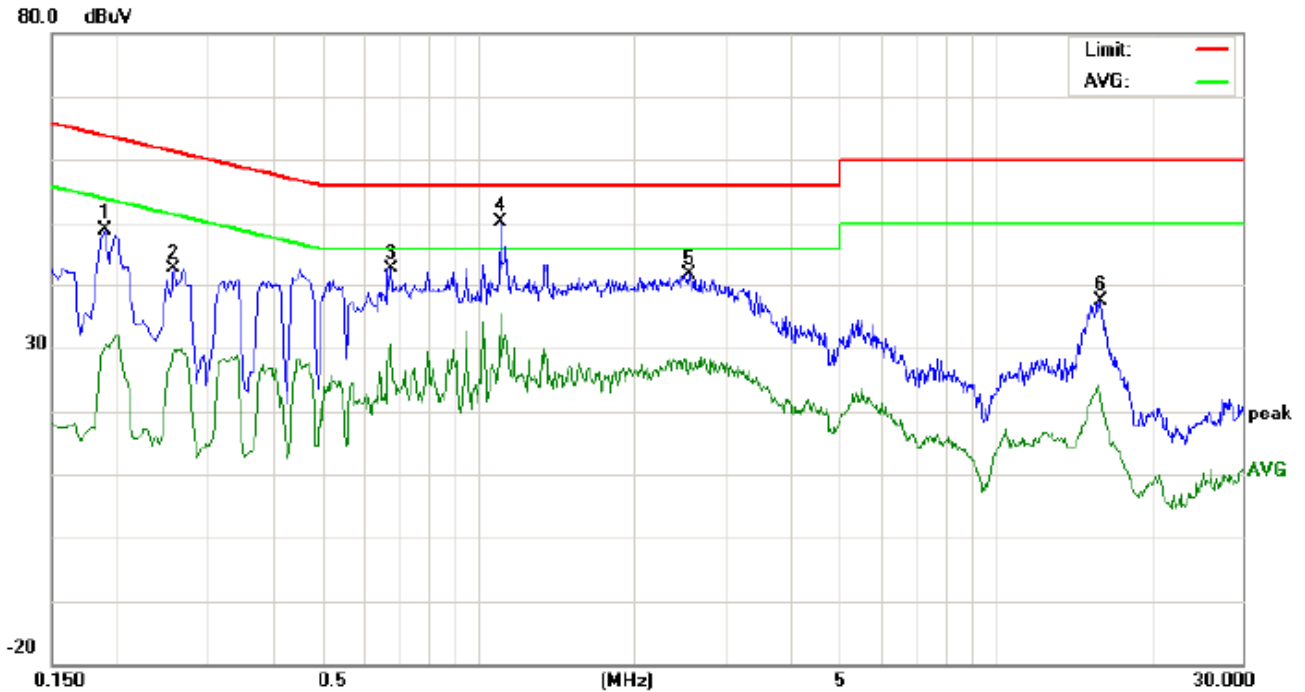

Site: Conduction Phase: **L1** Temperature: 22.9
Limit: FCC Class B Conduction(QP) Power: Humidity: 56.3 %
EUT: Bluetooth Receiver
M/N: AU04
Mode: BT Link
Note:

No.	Freq. (MHz)	Reading_Level (dBuV)			Correct Factor (dB)	Measurement (dBuV)			Limit (dBuV)		Margin (dB)		P/F	Comment
		Peak	QP	AVG		Peak	QP	AVG	QP	AVG	QP	AVG		
1	0.1900	38.75		20.51	10.20	48.95		30.71	64.03	54.03	-15.08	-23.32	P	
2	0.2580	32.29		19.46	10.27	42.56		29.73	61.49	51.49	-18.93	-21.76	P	
3	0.6820	32.35		18.98	10.34	42.69		29.32	56.00	46.00	-13.31	-16.68	P	
4	1.1019	39.77		24.88	10.37	50.14		35.25	56.00	46.00	-5.86	-10.75	P	
5	2.5660	31.27		17.06	10.45	41.72		27.51	56.00	46.00	-14.28	-18.49	P	
6	15.9300	27.37		12.05	10.11	37.48		22.16	60.00	50.00	-22.52	-27.84	P	

Line Conducted Emission Test Line 2-N

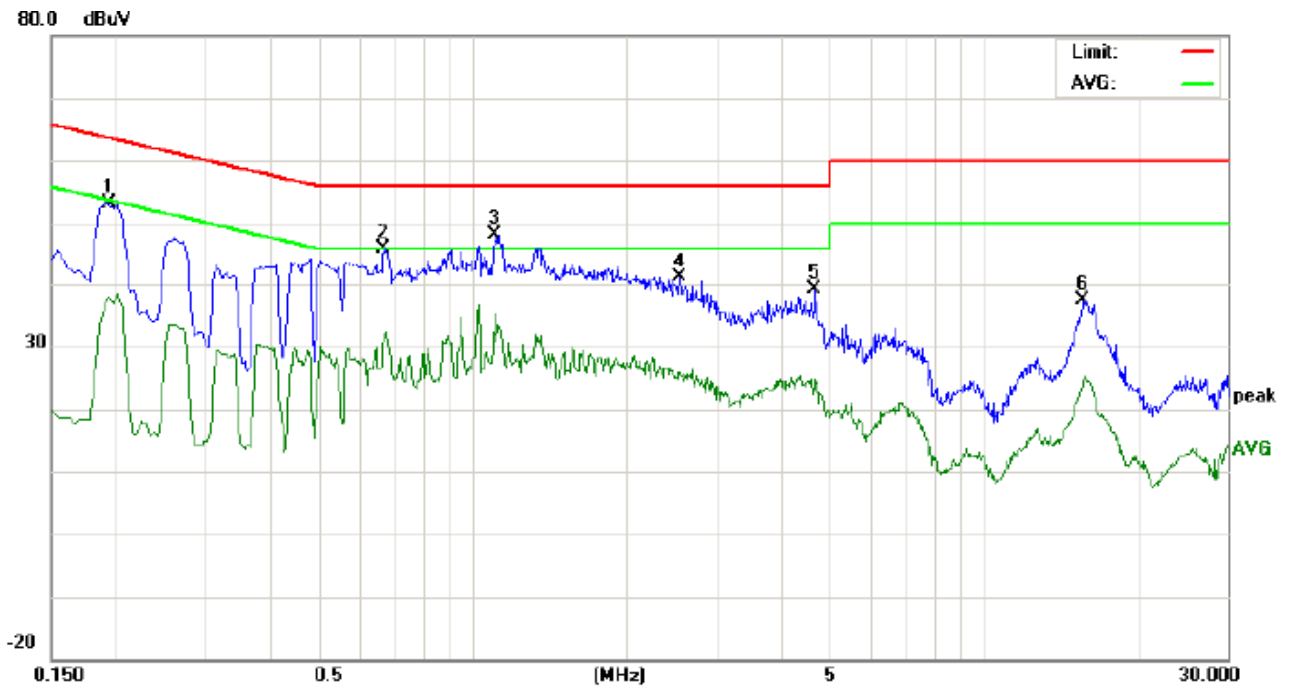

Site: Conduction Phase: *N* Temperature: 22.9
Limit: FCC Class B Conduction(QP) Power: Humidity: 56.3 %
EUT: Bluetooth Receiver
M/N: AU04
Mode: BT Link
Note:

No.	Freq. (MHz)	Reading_Level (dBuV)			Correct Factor	Measurement (dBuV)			Limit (dBuV)		Margin (dB)		P/F	Comment
		Peak	QP	AVG		dB	Peak	QP	AVG	QP	AVG	QP		
1	0.1940	42.95		27.72	10.21	53.16		37.93	63.86	53.86	-10.70	-15.93	P	
2	0.6700	35.61		20.44	10.34	45.95		30.78	56.00	46.00	-10.05	-15.22	P	
3	1.1019	37.78		24.74	10.37	48.15		35.11	56.00	46.00	-7.85	-10.89	P	
4	2.5420	30.77		15.39	10.44	41.21		25.83	56.00	46.00	-14.79	-20.17	P	
5	4.6860	29.02		14.54	10.22	39.24		24.76	56.00	46.00	-16.76	-21.24	P	
6	15.6620	27.24		14.22	10.11	37.35		24.33	60.00	50.00	-22.65	-25.67	P	

FOR BLE

Line Conducted Emission Test Line 1-L

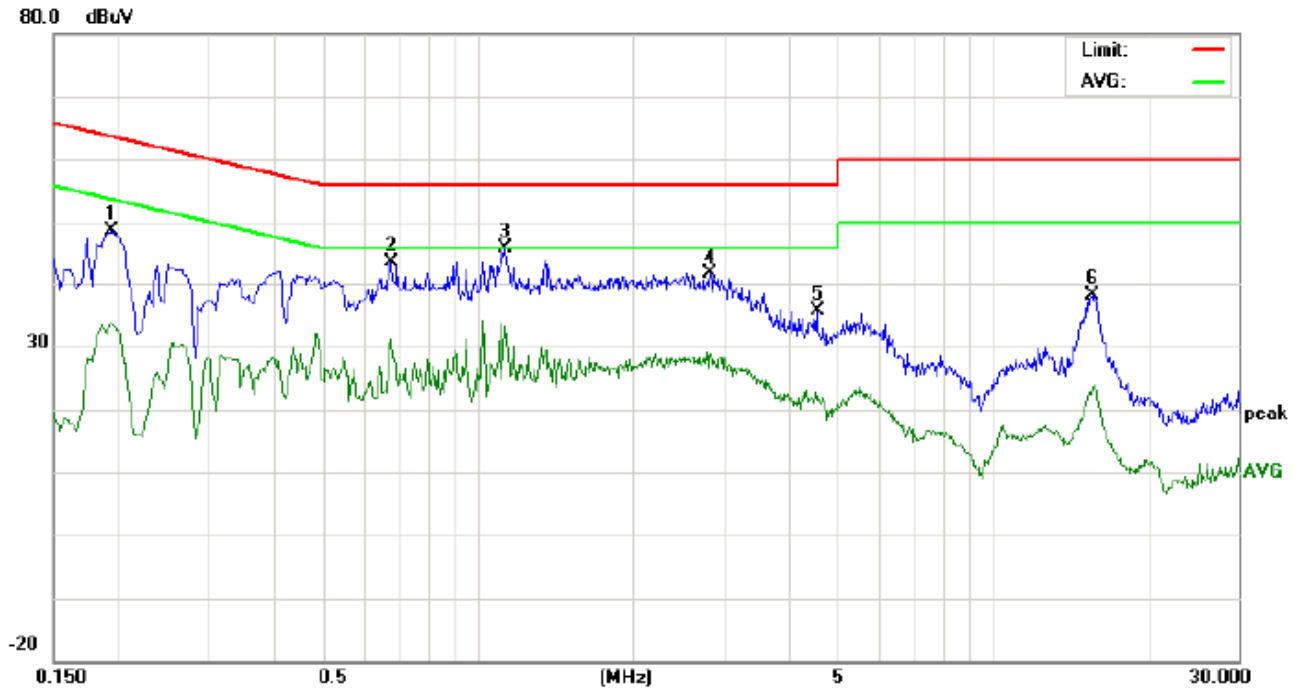

Site: Conduction Phase: *L1* Temperature: 22.9
Limit: FCC Class B Conduction(QP) Power: Humidity: 56.3 %
EUT: Bluetooth Receiver
M/N: AU04
Mode: BT Link
Note:

No.	Freq. (MHz)	Reading_Level (dBuV)			Correct Factor (dB)	Measurement (dBuV)			Limit (dBuV)		Margin (dB)		P/F	Comment
		Peak	QP	AVG		Peak	QP	AVG	QP	AVG	QP	AVG		
1	0.1940	38.34		23.52	10.21	48.55		33.73	63.86	53.86	-15.31	-20.13	P	
2	0.6780	33.27		20.79	10.34	43.61		31.13	56.00	46.00	-12.39	-14.87	P	
3	1.1340	35.51		22.72	10.37	45.88		33.09	56.00	46.00	-10.12	-12.91	P	
4	2.8260	31.18		18.36	10.51	41.69		28.87	56.00	46.00	-14.31	-17.13	P	
5	4.5500	25.42		11.42	10.21	35.63		21.63	56.00	46.00	-20.37	-24.37	P	
6	15.6260	27.98		13.23	10.11	38.09		23.34	60.00	50.00	-21.91	-26.66	P	

Line Conducted Emission Test Line 2-N

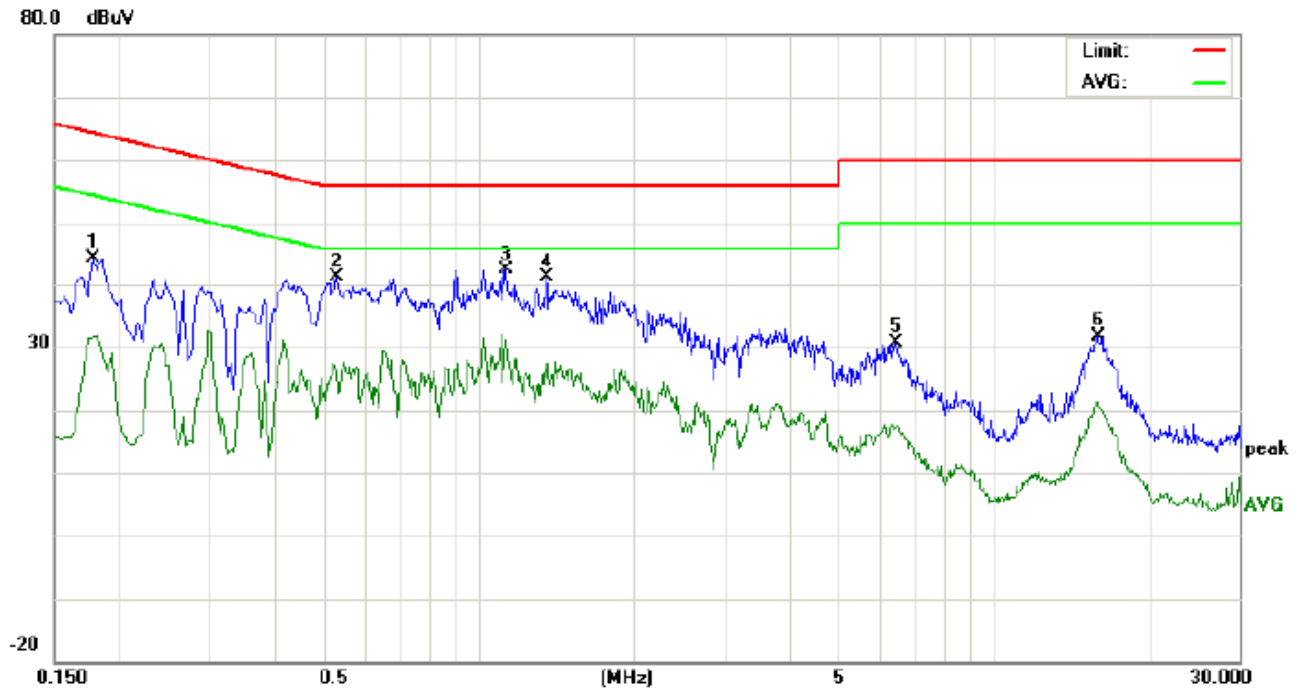

Site: Conduction Phase: **N** Temperature: 22.9
 Limit: FCC Class B Conduction(QP) Power: Humidity: 56.3 %
 EUT: Bluetooth Receiver
 M/N: AU04
 Mode: BT Link
 Note:

No.	Freq. (MHz)	Reading_Level (dBuV)			Correct Factor (dB)	Measurement (dBuV)			Limit (dBuV)		Margin (dB)		P/F	Comment
		Peak	QP	AVG		Peak	QP	AVG	QP	AVG	QP	AVG		
1	0.1780	34.30		21.45	10.19	44.49		31.64	64.57	54.57	-20.08	-22.93	P	
2	0.5299	30.77		16.06	10.37	41.14		26.43	56.00	46.00	-14.86	-19.57	P	
3	1.1300	32.03		20.70	10.37	42.40		31.07	56.00	46.00	-13.60	-14.93	P	
4	1.3540	30.80		14.98	10.38	41.18		25.36	56.00	46.00	-14.82	-20.64	P	
5	6.4660	20.27		6.89	10.30	30.57		17.19	60.00	50.00	-29.43	-32.81	P	
6	15.9100	21.61		11.25	10.11	31.72		21.36	60.00	50.00	-28.28	-28.64	P	

APPENDIX A: PHOTOGRAPHS OF TEST SETUP
FCC LINE CONDUCTED EMISSION TEST SETUP

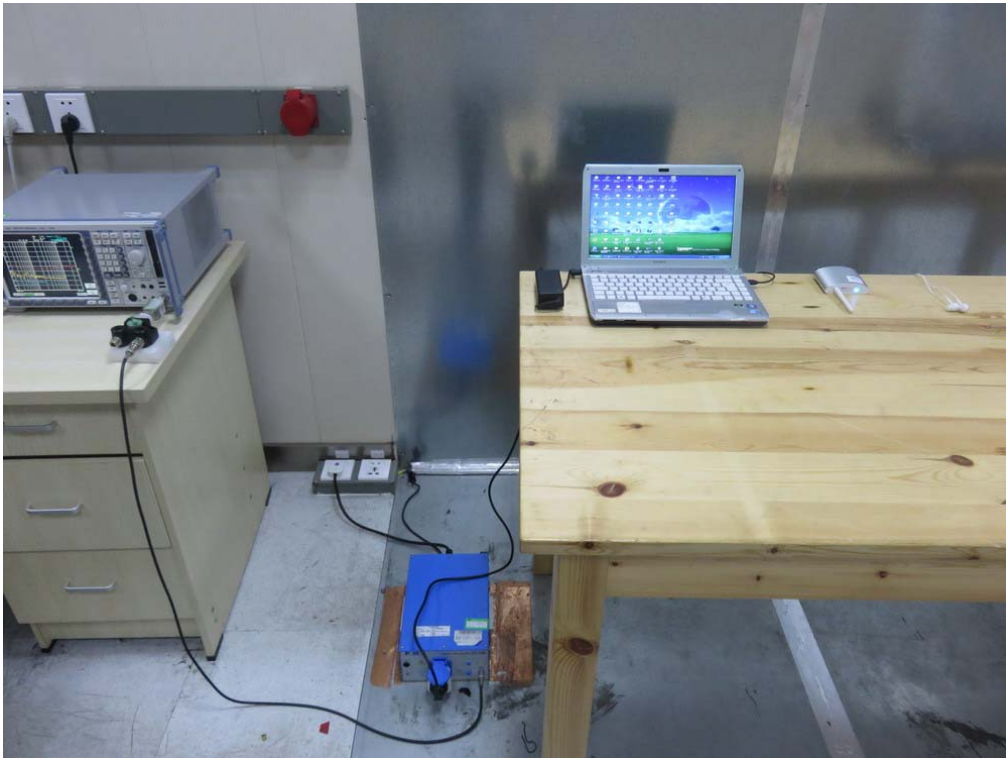

FCC RADIATED EMISSION TEST SETUP

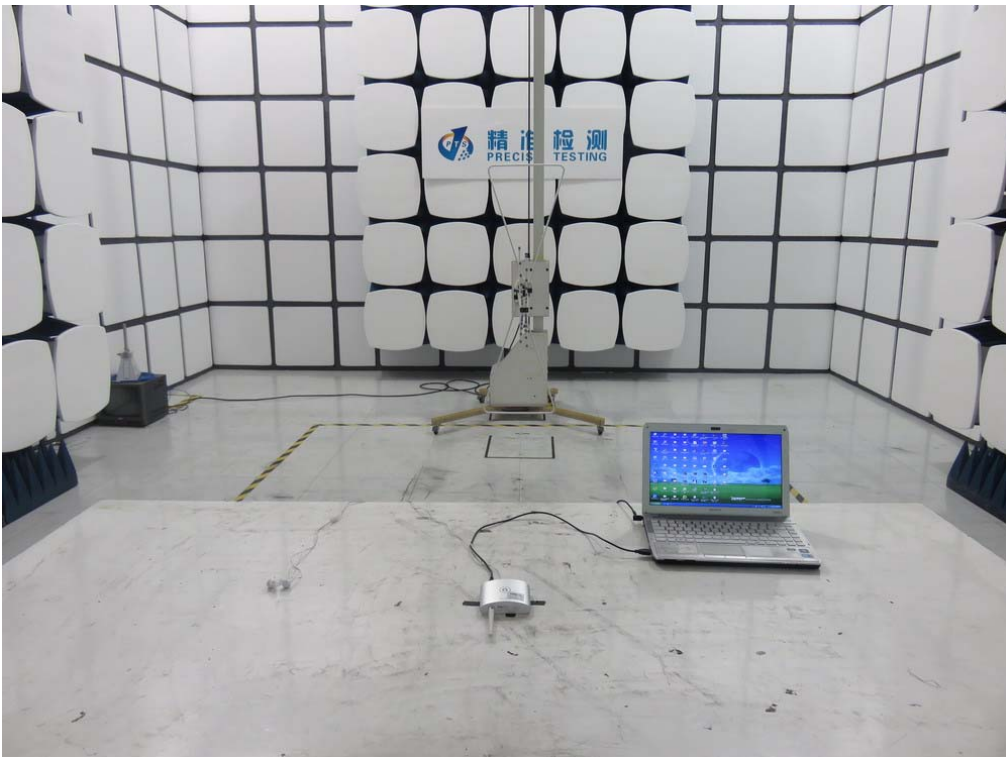

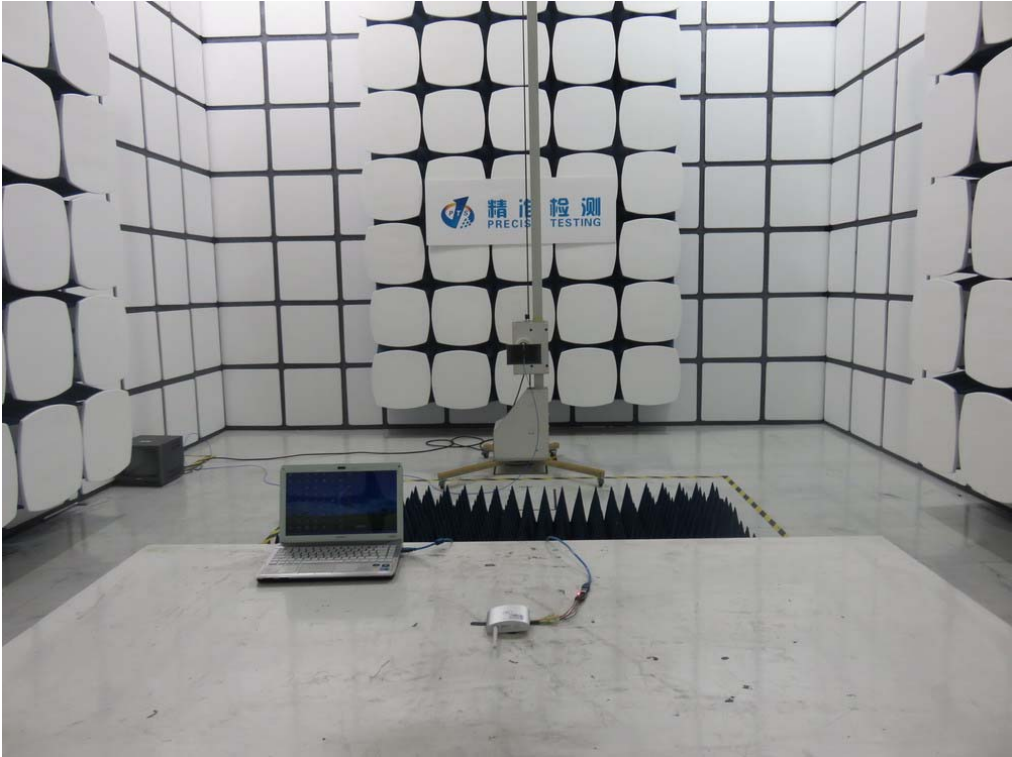

APPENDIX B: PHOTOGRAPHS OF EUT
TOP VIEW OF EUT



BOTTOM VIEW OF EUT

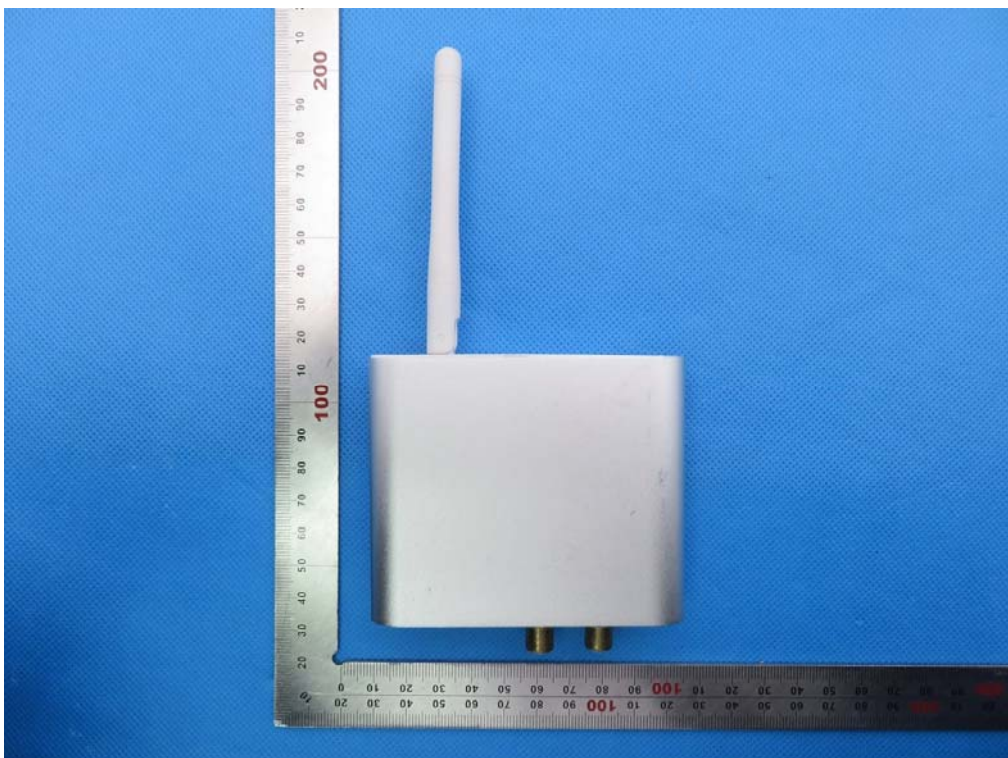

FRONT VIEW OF EUT



BACK VIEW OF EUT

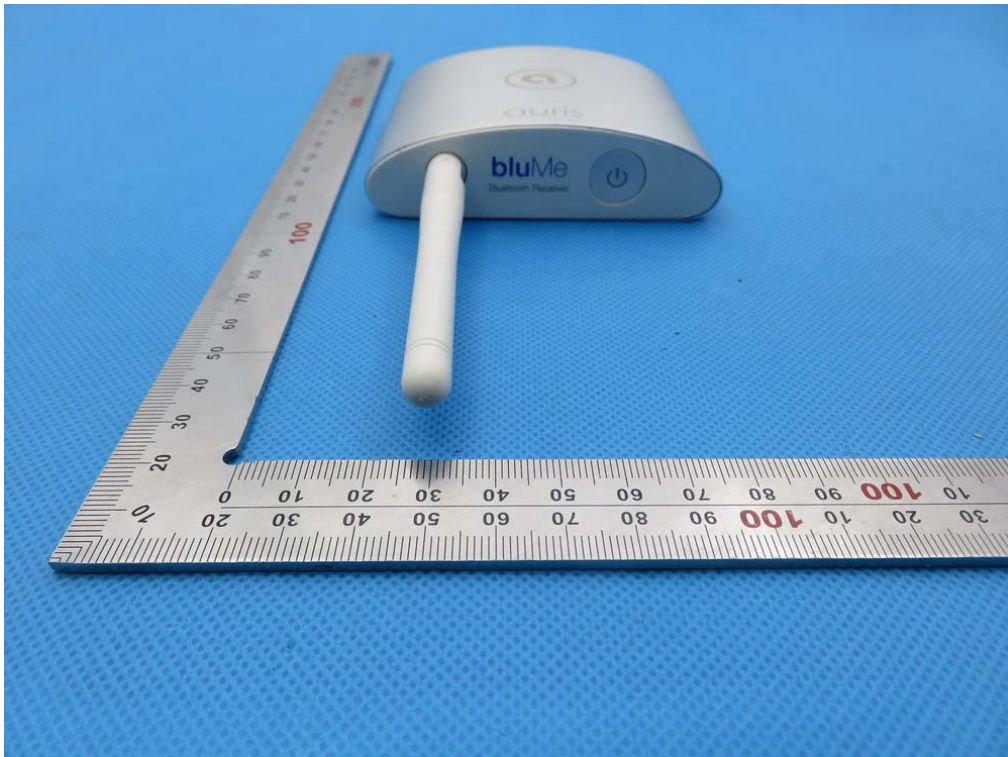

LEFT VIEW OF EUT



RIGHT VIEW OF EUT



VIEW OF EUT (PORT)



OPEN VIEW OF EUT

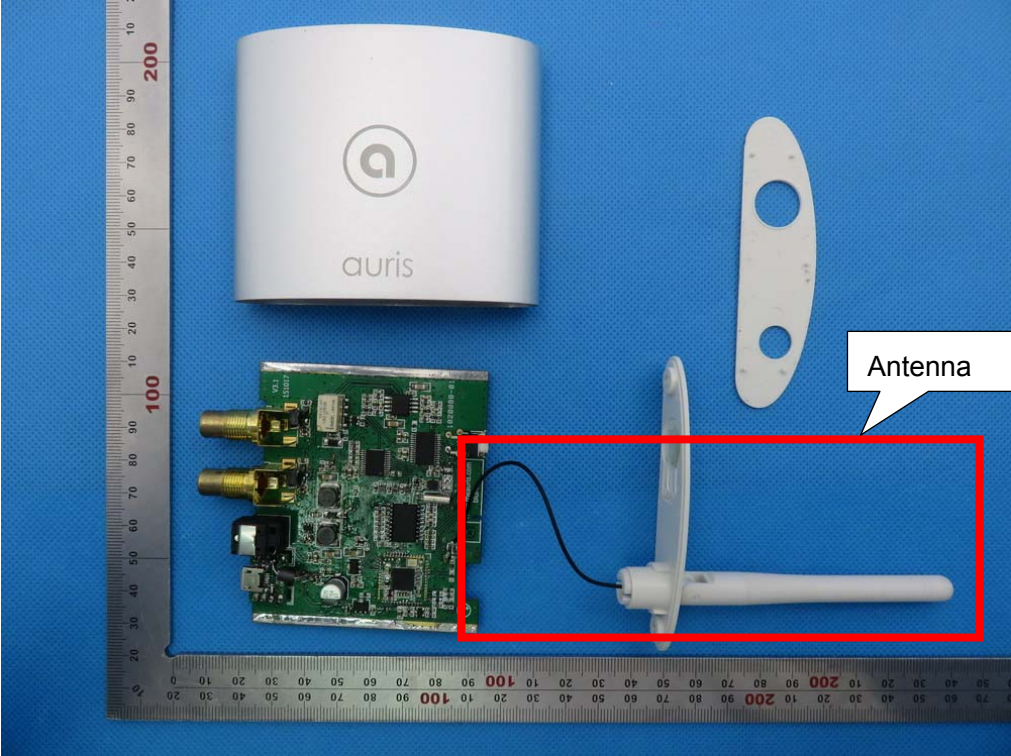

INTERNAL VIEW OF EUT-1

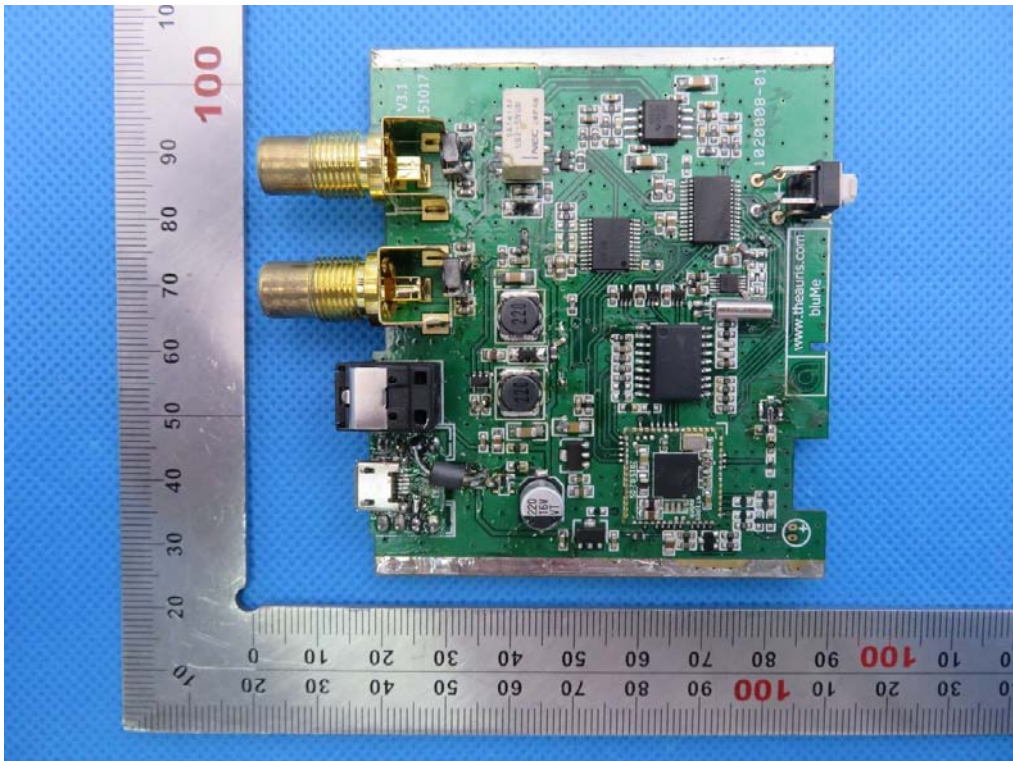

INTERNAL VIEW OF EUT-2

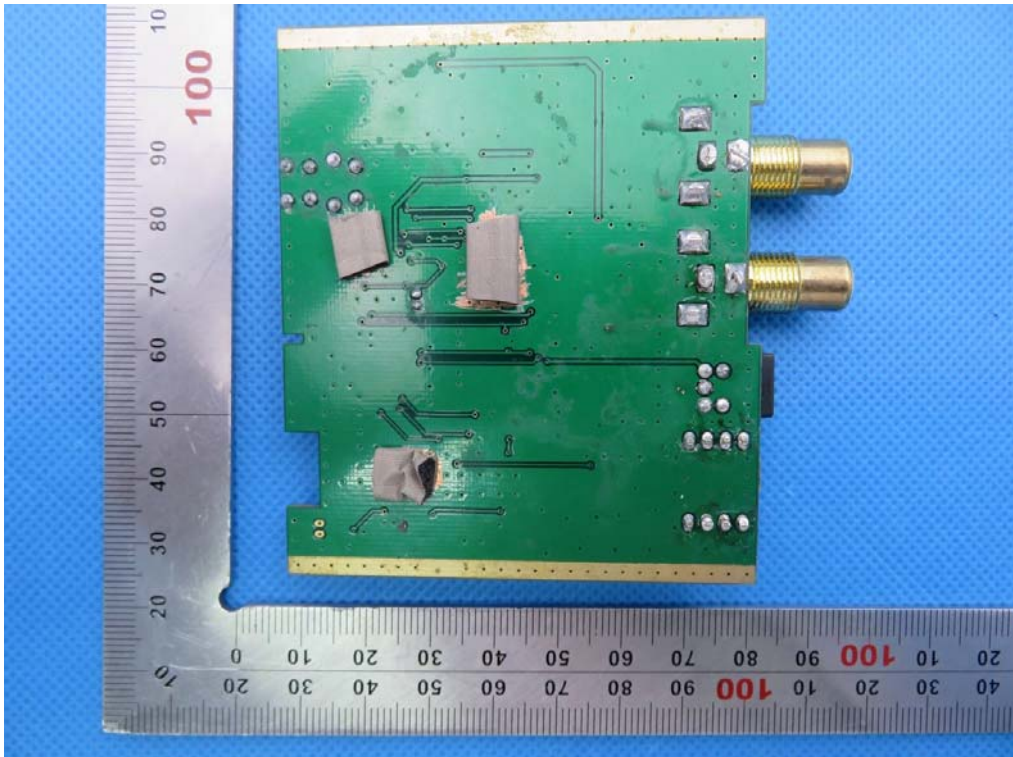

INTERNAL VIEW OF EUT-3

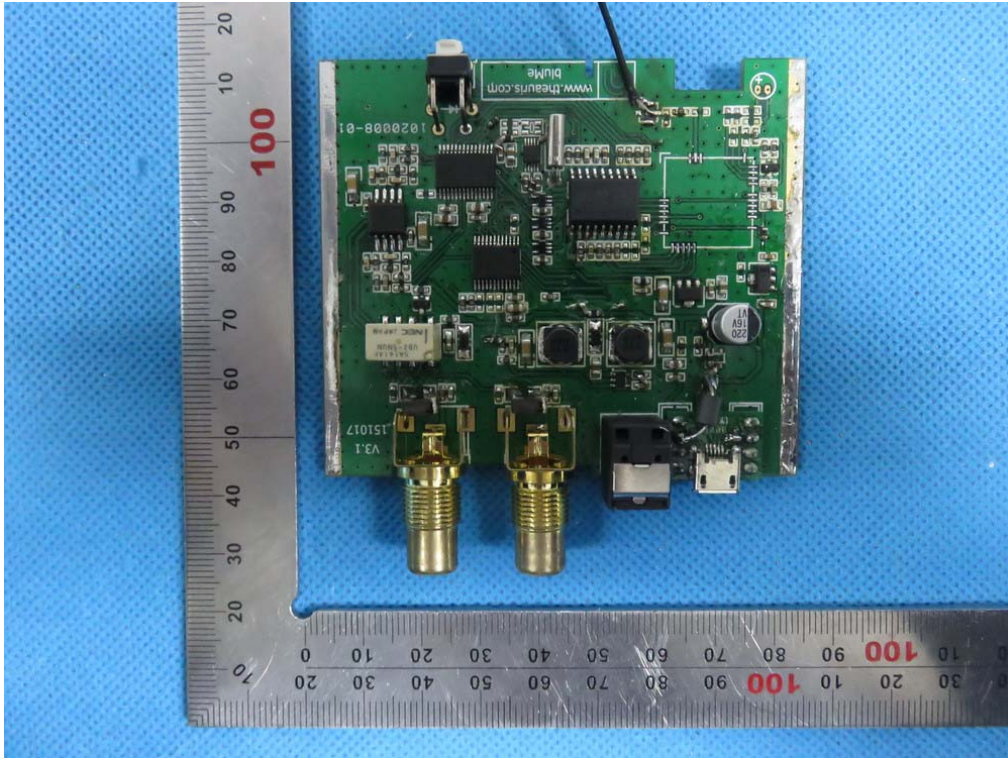

INTERNAL VIEW OF EUT-4

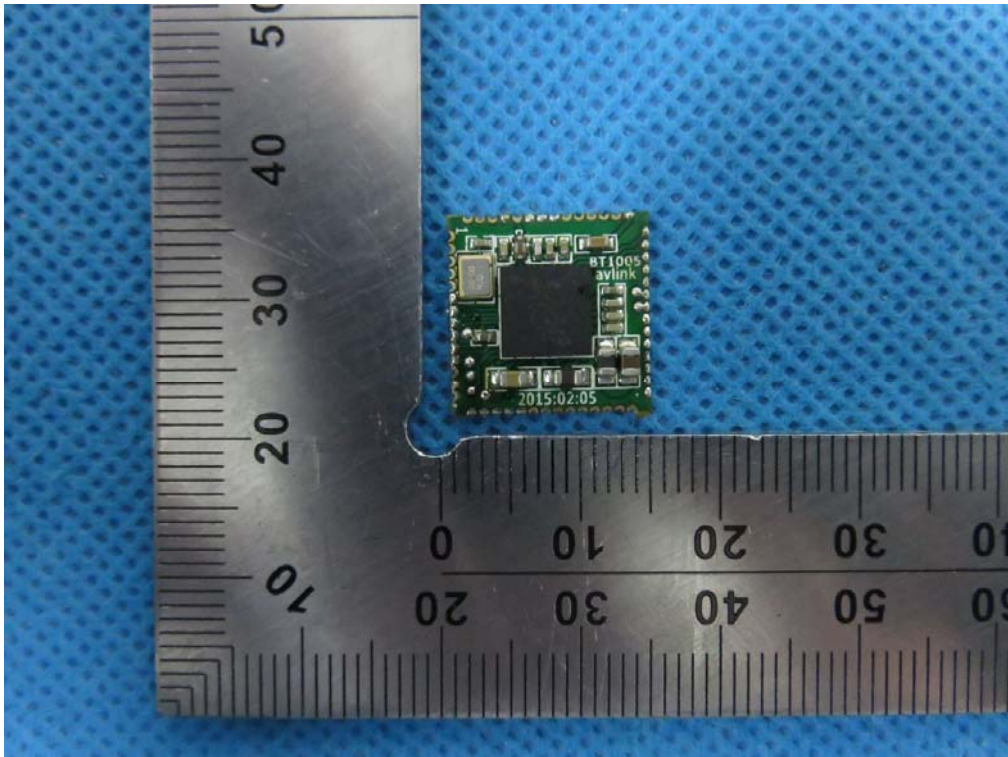

INTERNAL VIEW OF EUT-5

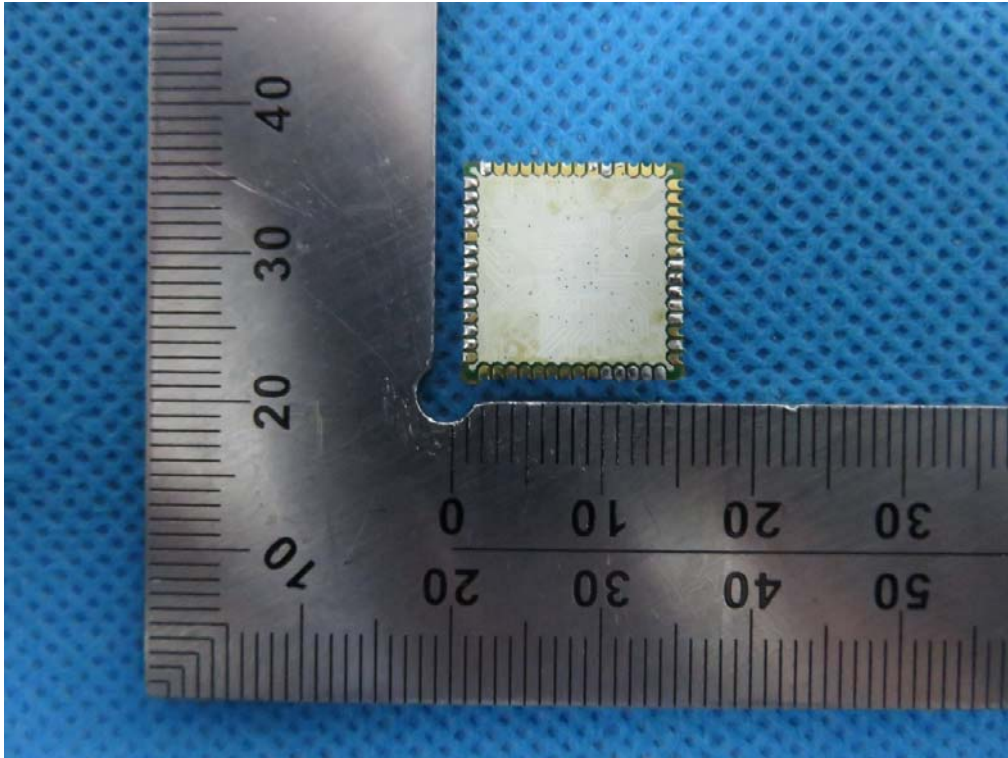

----END OF REPORT----