

TEST REPORT

Test Report No. : UL-RPT-RP14705831-1016B

Customer : Raspberry Pi LTD
Model No. / HVIN : V2.0
PMN : Raspberry Pi 5
FCC ID : 2ABCB-RPI5
ISED Certification No. : IC: 20953-RPI5
Test Standard(s) : FCC Part 15.207
Innovation, Science and Economic Development Canada
RSS-Gen Issue 5 February 2021
Test Laboratory : UL International (UK) Ltd, Basingstoke, Hampshire, RG24 8AH,
United Kingdom

1. This test report shall not be reproduced except in full, without the written approval of UL International (UK) Ltd.
2. The results in this report apply only to the sample(s) tested.
3. The sample tested is in compliance with the above standard(s).
4. The test results in this report are traceable to the national or international standards.
5. Version 2.0 supersedes all previous versions.

Date of Issue: 17 October 2023

Checked by:



Ben Mercer
Lead Project Engineer, Radio Laboratory

Company Signatory:

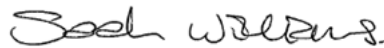

Sarah Williams
RF Operations Leader, Radio Laboratory



The *Bluetooth*[®] word mark and logos are owned by the *Bluetooth* SIG, Inc. and any use of such marks by UL International (UK) Ltd is under licence. Other trademarks and trade names are those of their respective owners.

Customer Information

Company Name:	Raspberry Pi LTD
Address:	Maurice Wilkes Building St. John's Innovation Park, Cambridge, CB4 0DS, United Kingdom

Report Revision History

Version Number	Issue Date	Revision Details	Revised By
1.0	15/09/2023	Initial Version	Ben Mercer
2.0	17/10/2023	FVIN removed	Ben Mercer

Table of Contents

Customer Information	2
Report Revision History	2
Table of Contents.....	3
1 Attestation of Test Results	4
1.1 Description of EUT	4
1.2 General Information	4
1.3 Summary of Test Results	4
1.4 Deviations from the Test Specification	4
2 Summary of Testing	5
2.1 Facilities and Accreditation	5
2.2 Methods and Procedures	5
2.3 Calibration and Uncertainty	6
2.4 Test and Measurement Equipment	7
3 Equipment Under Test (EUT)	8
3.1 Identification of Equipment Under Test (EUT)	8
3.2 Modifications Incorporated in the EUT	8
3.3 Additional Information Related to Testing	9
3.4 Description of Available Antennas	10
3.5 Description of Test Setup	11
4 AC Power Line Conducted Emissions Test Results	14
4.1 Transmitter AC Conducted Spurious Emissions	14

1 Attestation of Test Results

1.1 Description of EUT

The equipment under test was a single board computer with *Bluetooth*, 2.4 GHz WLAN and 5 GHz WLAN transceivers.

1.2 General Information

Specification Reference:	47CFR15.207
Specification Title:	Code of Federal Regulations Volume 47 (Telecommunications): Part 15 Subpart C (Intentional Radiators) – Section 15.207
Specification Reference:	RSS-Gen Issue 5 February 2021
Specification Title:	General Requirements for Compliance of Radio Apparatus
Site Registration:	FCC: 685609, ISEDC: 20903
FCC Lab. Designation No.:	UK2011
ISEDC CABID:	UK0001
Location of Testing:	Unit 3 Horizon, Wade Road, Kingsland Business Park, Basingstoke, Hampshire, G24 8AH, United Kingdom
Test Dates:	28 July 2023

1.3 Summary of Test Results

FCC Reference (47CFR)	ISED Canada Reference	Measurement	Result
Part 15.207	RSS-Gen 8.8	Transmitter AC Conducted Emissions	Complied

1.4 Deviations from the Test Specification

For the measurements contained within this test report, there were no deviations from, additions to, or exclusions from the test specification identified above.

2 Summary of Testing

2.1 Facilities and Accreditation

The test site and measurement facilities used to collect data are located at Unit 3 Horizon, Wade Road, Kingsland Business Park, Basingstoke, Hampshire, RG24 8AH, United Kingdom.

UL International (UK) Ltd is accredited by the United Kingdom Accreditation Service (UKAS). UKAS is one of the signatories to the International Laboratory Accreditation Co-operation (ILAC) Arrangement for the mutual recognition of test reports. The tests reported herein have been performed in accordance with its terms of accreditation.

2.2 Methods and Procedures

Reference:	ANSI C63.10-2013
Title:	American National Standard of Procedures for Compliance Testing of Unlicensed Wireless Devices
Reference:	KDB 174176 D01 Line Conducted FAQ v01r01 June 3, 2015
Title:	AC Power-Line Conducted Emissions Frequently Asked Questions

2.3 Calibration and Uncertainty

Measuring Instrument Calibration

In accordance with UKAS requirements all the measurement equipment is on a calibration schedule. All equipment was within the calibration period on the date of testing.

Measurement Uncertainty & Decision Rule

Overview

No measurement or test can ever be perfect and the imperfections give rise to error of measurement in the results. Consequently the result of a measurement is only an approximation to the value of the measurand (the specific quantity subject to measurement) and is only complete when accompanied by a statement of the uncertainty of the approximation.

The expression of uncertainty of a measurement result allows realistic comparison of results with reference values and limits given in specifications and standards.

Decision Rule

The decision rule applied is based upon the accuracy method criteria. The measurement uncertainty is met and the result is considered in conformance with the requirement criteria if the observed value is within the prescribed limit.

Measurement Uncertainty

The reported expanded uncertainties below are based on a standard uncertainty multiplied by an appropriate coverage factor such that a confidence level of approximately 95% is maintained. For the purposes of this document “approximately” is interpreted as meaning “effectively” or “for most practical purposes”.

Measurement Type	Range	Confidence Level (%)	Calculated Uncertainty
AC Conducted Spurious Emissions	0.15 MHz to 30 MHz	95%	±2.42 dB

The methods used to calculate the above uncertainties are in line with those recommended within the various measurement specifications. Where measurement specifications do not include guidelines for the evaluation of measurement uncertainty the published guidance of the appropriate accreditation body is followed.

2.4 Test and Measurement Equipment

Test Equipment Used

Asset No.	Instrument	Manufacturer	Type No.	Serial No.	Date Calibration Due	Cal. Interval (Months)
M2037	Thermohygrometer	Testo	608-H1	45124925	08 Dec 2023	12
M1124	Test Receiver	Rohde & Schwarz	ESIB26	100046	06 Oct 2023	12
A649	LISN	Rohde & Schwarz	ESH3-Z5	825562/008	01 Sep 2023	12
A1830	Pulse Limiter	Rohde & Schwarz	ESH3-Z2	100668	01 Jun 2024	12

Test Measurement Software/Firmware Used:

Name	Version	Release Date
Rohde & Schwarz EMC32	6.30.0	2018

3 Equipment Under Test (EUT)

3.1 Identification of Equipment Under Test (EUT)

Brand Name:	Raspberry Pi
Model Name or Number / HVIN:	V2.0
PMN:	Raspberry Pi 5
Test Sample Serial Number:	R29
Hardware Version:	V2.0
Software Version:	V1.0
FCC ID:	2ABCB-RPI5
ISED Canada Certification Number:	IC: 20953-RPI5
Date of Receipt:	17 May 2023

3.2 Modifications Incorporated in the EUT

No modifications were applied to the EUT during testing.

3.3 Additional Information Related to Testing

Technology Tested:	<i>Bluetooth</i>		
Channel Spacing:	1 MHz		
Mode:	Basic Data Rate		
Modulation:	GFSK		
Packet Type (Maximum Payload):	DH5		
Data Rate:	1 Mbps		
Transmit Frequency Range:	2402 MHz to 2480 MHz		
Transmit Channels Tested:	Channel ID	Channel Number	Channel Frequency (MHz)
	Middle	39	2441

Technology Tested:	<i>Bluetooth</i> Low Energy (Digital Transmission System)		
Channel Spacing:	2 MHz		
Modulation:	GFSK		
Data Rate:	1 Mbps (LE1M)		
Transmit Frequency Range:	2402 MHz to 2480 MHz		
Transmit Channels Tested:	Channel ID	Channel Number	Channel Frequency (MHz)
	Middle	17	2440

Technology Tested:	WLAN (IEEE 802.11b,g,n) / Digital Transmission System		
Channel Spacing:	20 MHz		
Modulation:	BPSK		
Data Rate:	802.11n HT20	MCS0 (SISO)	
Transmit Frequency Range:	2412 MHz to 2472 MHz		
Transmit Channels Tested:	Channel ID	Channel Number	Channel Frequency (MHz)
	Bottom	1	2412

Technology Tested:	WLAN (IEEE 802.11a,n,ac) / U-NII		
Channel Spacing:	20 MHz		
Modulation:	BPSK		
Data Rate:	802.11n HT20	MCS0	
Transmit Frequency Band:	5470 MHz to 5725 MHz		
Transmit Channels Tested:	Channel ID	Channel Number	Channel Frequency (MHz)
	Top	140	5700

3.4 Description of Available Antennas

The radio utilises an integrated antenna, with the following maximum gain:

Frequency Range (MHz)	Antenna Gain (dBi)
2400 to 2480	3.5
5150 to 5850	2.5

3.5 Description of Test Setup

Support Equipment

The following support equipment was used to exercise the EUT during testing:

Description:	Test Laptop
Brand Name:	Lenovo
Model Name or Number:	L480
Serial Number:	PF1EJ3BY

Description:	AC to DC Power Adaptor
Brand Name:	Raspberry Pi
Model Name or Number:	KSA-15E-051300HK
Serial Number:	Not stated or marked

Description:	ThinkPad USB-C Docking station
Brand Name:	Lenovo
Model Name or Number:	Type 4049
Serial Number:	Not stated or marked

Description:	Micro-HDMI Cable. Length 1m. Quantity 2.
Brand Name:	Raspberry Pi
Model Name or Number:	SC0270
Serial Number:	Not stated or marked

Description:	USB/HDMI/Ethernet Termination Hub. Quantity 2.
Brand Name:	Lemorele
Model Name or Number:	TC19
Serial Number:	Not stated or marked

Description:	USB Type A Cable. Length 3m. Quantity 4.
Brand Name:	Not marked or stated
Model Name or Number:	Not marked or stated
Serial Number:	Not marked or stated

Description:	Ethernet Cable. Length 2m. Quantity 1.
Brand Name:	Not marked or stated
Model Name or Number:	Not marked or stated
Serial Number:	Not marked or stated

Operating Modes

The EUT was tested in the following operating mode(s):

- Transmitting at maximum power in the relevant mode as required.
- The EUT was tested in the following operating mode(s): Pre-scans were performed with the EUT transmitting in *Bluetooth* BDR, *Bluetooth* LE, 2.4 GHz and 5 GHz WLAN modes individually. The worst-case mode was found to be *Bluetooth* LE. Final measurements were performed in this configuration.

Configuration and Peripherals

The EUT was tested in the following configuration(s):

- Controlled in test mode using a set of commands entered into a terminal application on the EUT supplied by the customer. The commands were used to enable a continuous transmission and to select the test channels as required. The customer supplied a document containing the setup instructions.
- All active ports were populated using suitable terminations.

Test Setup Diagrams

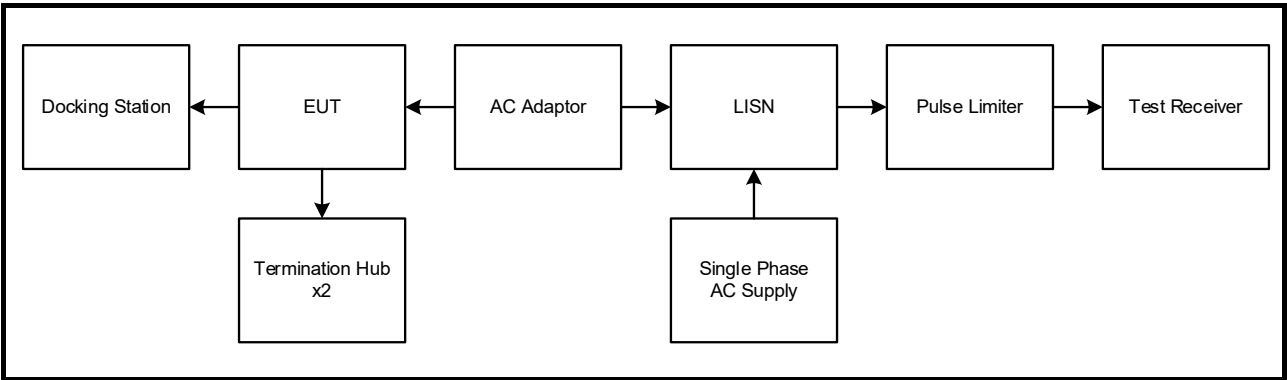

4 AC Power Line Conducted Emissions Test Results

4.1 Transmitter AC Conducted Spurious Emissions

Test Summary:

Test Engineer:	Andrew Edwards	Test Date:	28 July 2023
Test Sample Serial Number:	R29		

FCC Reference:	Part 15.207
Test Method Used:	ANSI C63.10 Section 6.2 / FCC KDB 174176 and notes below

Environmental Conditions:

Temperature (°C):	25
Relative Humidity (%):	63

Note(s):

1. The EUT was connected to an AC adaptor. The AC adaptor was connected to 120 VAC 60 Hz single phase supply via a LISN.
2. In accordance with FCC KDB 174176 Q4, tests were performed with a 240 VAC 60 Hz single phase supply as this was within the voltage range marked on the 100 to 240V power supply.
3. A pulse limiter was fitted between the LISN and the test receiver.
4. Pre-scans were performed and markers placed on the highest live and neutral measured levels. Final measurements were performed on the marker frequencies and the results entered into the tables below.

Transmitter AC Conducted Spurious Emissions (continued)**Results: Live / Quasi Peak / 120 VAC 60 Hz**

Frequency (MHz)	Line	Level (dB μ V)	Limit (dB μ V)	Margin (dB)	Result
0.150	Live	58.5	66.0	7.5	Complied
0.258	Live	51.5	61.5	10.0	Complied
0.285	Live	49.5	60.7	11.2	Complied
0.303	Live	48.1	60.2	12.1	Complied
0.438	Live	41.9	57.1	15.2	Complied
0.501	Live	41.4	56.0	14.6	Complied

Results: Live / Average / 120 VAC 60 Hz

Frequency (MHz)	Line	Level (dB μ V)	Limit (dB μ V)	Margin (dB)	Result
0.155	Live	33.7	55.8	22.1	Complied
0.164	Live	32.0	55.3	23.3	Complied
0.249	Live	22.7	51.8	29.1	Complied
0.420	Live	24.7	47.4	22.7	Complied
0.497	Live	28.3	46.1	17.8	Complied
0.821	Live	22.4	46.0	23.6	Complied

Results: Neutral / Quasi Peak / 120 VAC 60 Hz

Frequency (MHz)	Line	Level (dB μ V)	Limit (dB μ V)	Margin (dB)	Result
0.150	Neutral	58.5	66.0	7.5	Complied
0.155	Neutral	58.1	65.8	7.7	Complied
0.182	Neutral	56.5	64.4	7.9	Complied
0.285	Neutral	48.8	60.7	11.9	Complied
0.308	Neutral	49.0	60.0	11.0	Complied
0.510	Neutral	42.4	56.0	13.6	Complied

Results: Neutral / Average / 120 VAC 60 Hz

Frequency (MHz)	Line	Level (dB μ V)	Limit (dB μ V)	Margin (dB)	Result
0.155	Neutral	32.0	55.8	23.8	Complied
0.164	Neutral	30.0	55.3	25.3	Complied
0.218	Neutral	25.7	52.9	27.2	Complied
0.272	Neutral	21.6	51.1	29.5	Complied
0.357	Neutral	18.4	48.8	30.4	Complied
0.492	Neutral	22.3	46.1	23.8	Complied

Transmitter AC Conducted Spurious Emissions (continued)

Results: 120 VAC 60 Hz

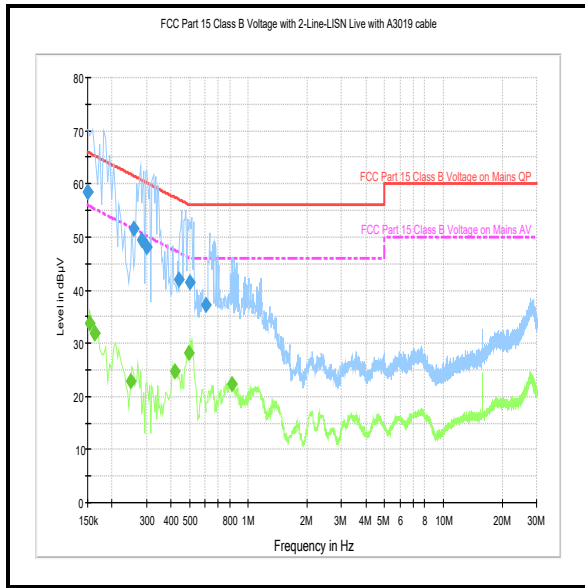

Live

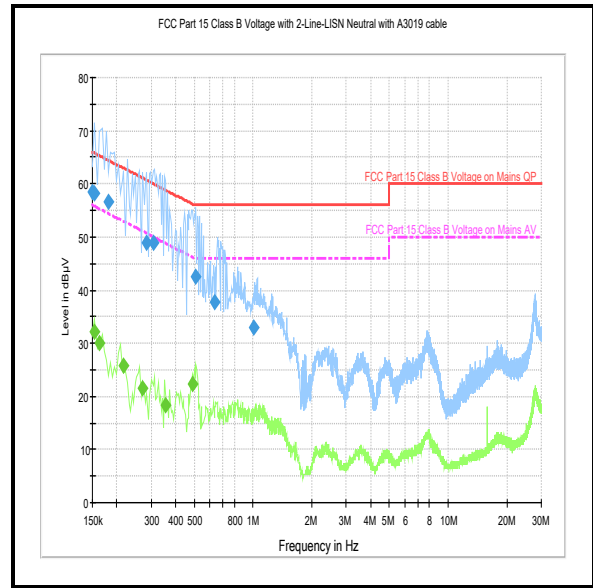

Neutral

Note: These plots are pre-scans and for indication purposes only. For final measurements, see accompanying tables.

Transmitter AC Conducted Spurious Emissions (continued)**Results: Live / Quasi Peak / 240 VAC 60 Hz**

Frequency (MHz)	Line	Level (dB μ V)	Limit (dB μ V)	Margin (dB)	Result
0.173	Live	43.7	64.8	21.1	Complied
0.249	Live	40.3	61.8	21.5	Complied
0.339	Live	39.9	59.2	19.3	Complied
0.479	Live	37.9	56.4	18.5	Complied
0.785	Live	33.2	56.0	22.8	Complied
0.879	Live	33.4	56.0	22.6	Complied

Results: Live / Average / 240 VAC 60 Hz

Frequency (MHz)	Line	Level (dB μ V)	Limit (dB μ V)	Margin (dB)	Result
0.168	Live	31.8	55.1	23.3	Complied
0.168	Live	31.8	55.1	23.3	Complied
0.254	Live	29.2	51.6	22.4	Complied
0.339	Live	28.6	49.2	20.6	Complied
0.474	Live	30.4	46.4	16.0	Complied
0.879	Live	23.7	46.0	22.3	Complied

Results: Neutral / Quasi Peak / 240 VAC 60 Hz

Frequency (MHz)	Line	Level (dB μ V)	Limit (dB μ V)	Margin (dB)	Result
0.168	Neutral	46.9	65.1	18.2	Complied
0.335	Neutral	40.9	59.3	18.4	Complied
0.348	Neutral	38.9	59.0	20.1	Complied
0.483	Neutral	40.8	56.3	15.5	Complied
0.537	Neutral	34.8	56.0	21.2	Complied
0.857	Neutral	35.0	56.0	21.0	Complied

Results: Neutral / Average / 240 VAC 60 Hz

Frequency (MHz)	Line	Level (dB μ V)	Limit (dB μ V)	Margin (dB)	Result
0.168	Neutral	26.0	55.1	29.1	Complied
0.213	Neutral	26.3	53.1	26.8	Complied
0.339	Neutral	23.0	49.2	26.2	Complied
0.479	Neutral	22.7	46.4	23.7	Complied
0.497	Neutral	21.7	46.1	24.4	Complied
0.897	Neutral	16.7	46.0	29.3	Complied

Transmitter AC Conducted Spurious Emissions (continued)

Results: 240 VAC 60 Hz

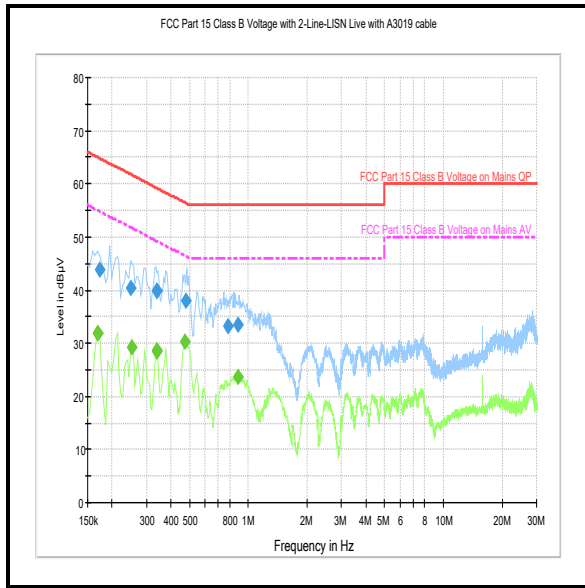

Live

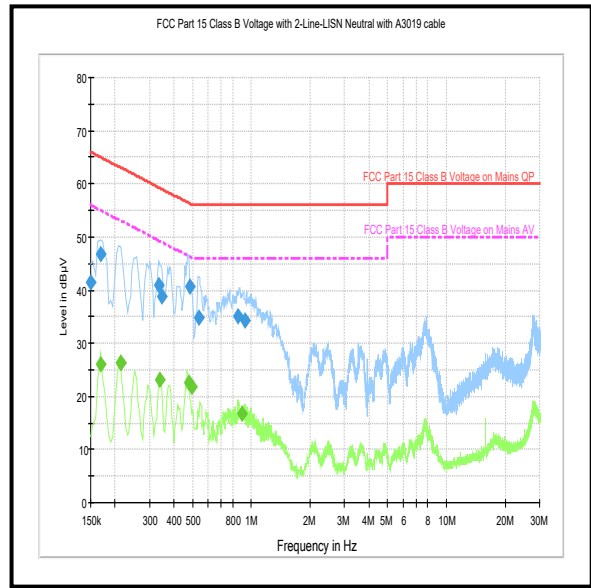

Neutral

Note: These plots are pre-scans and for indication purposes only. For final measurements, see accompanying tables.

--- END OF REPORT ---