

TEST REPORT

Test Report No. : UL-RPT-RP14705831-1216A

Customer : Raspberry Pi LTD
Model No. / HVIN : V2.0
PMN : Raspberry Pi 5
FCC ID : 2ABCB-RPI5
ISED Certification No. : IC: 20953-RPI5
Technology : WLAN
Test Standard(s) : FCC Parts 15.209(a) & 15.407
Innovation, Science and Economic Development Canada
RSS-247 Issue 2 February 2017
RSS-Gen Issue 5 February 2021
Test Laboratory : UL International (UK) Ltd, Basingstoke, Hampshire, RG24 8AH,
United Kingdom

1. This test report shall not be reproduced except in full, without the written approval of UL International (UK) Ltd
2. The results in this report apply only to the sample(s) tested.
3. The sample tested is in compliance with the above standard(s).
4. The test results in this report are traceable to the national or international standards.
5. Version 4.0 supersedes all previous versions.

Date of Issue: 17 October 2023

Checked by:



Ben Mercer
Lead Project Engineer, Radio Laboratory

Company Signatory:



Sarah Williams
RF Operations Leader, Radio Laboratory



Customer Information

Company Name:	Raspberry Pi LTD
Address:	Maurice Wilkes Building, St. John's Innovation Park, Cambridge, CB4 0DS, United Kingdom

Report Revision History

Version Number	Issue Date	Revision Details	Revised By
1.0	13/09/2023	Initial Version	Ben Mercer
2.0	13/09/2023	Q values removed	Ben Mercer
3.0	13/10/2023	Admin update	Ben Mercer
4.0	17/10/2023	FVIN removed	Ben Mercer

Table of Contents

Customer Information	2
Report Revision History	2
1 Attestation of Test Results.....	4
1.1 Description of EUT	4
1.2 General Information	4
1.3 Summary of Test Results	5
1.4 Deviations from the Test Specification	6
2 Summary of Testing	7
2.1 Facilities and Accreditation	7
2.2 Methods and Procedures	7
2.3 Calibration and Uncertainty	8
2.4 Test and Measurement Equipment	9
3 Equipment Under Test (EUT)	12
3.1 Identification of Equipment Under Test (EUT)	12
3.2 Modifications Incorporated in the EUT	12
3.3 Additional Information Related to Testing	13
3.4 Description of Available Antennas	16
3.5 Description of Test Setup	17
4 Antenna Port Test Results	21
4.1 Transmitter 26 dB and 99% Emission Bandwidth	21
4.1.1 5.15-5.25 GHz band	22
4.1.2 5.25-5.35 GHz band	26
4.1.3 5.47-5.725 GHz band	30
4.1.4 5.725-5.85 GHz band	37
4.2 Transmitter Maximum Conducted Output Power	44
4.2.1 5.15-5.25 GHz band	44
4.2.2 5.25-5.35 GHz band	49
4.2.3 5.47-5.725 GHz band	54
4.2.4 5.725-5.85 GHz band	59
4.3 Transmitter Maximum Power Spectral Density	64
4.3.1 5.15-5.25 GHz band	64
4.3.2 5.25-5.35 GHz band	70
4.3.3 5.47-5.725 GHz band	77
4.3.4 5.725-5.85 GHz band	86
5 Radiated Test Results	94
5.1 Transmitter Out of Band Radiated Emissions <1 GHz	94
5.2 Transmitter Out of Band Radiated Emissions >1 GHz	96
5.2.1 5.15-5.25 GHz band	96
5.2.2 5.25-5.35 GHz band	97
5.2.3 5.47-5.725 GHz band	98
5.2.4 5.725-5.85 GHz band	100
5.3 Transmitter Band Edge Radiated Emissions	101
5.3.1 5.15-5.25 GHz band	101
5.3.2 5.25-5.35 GHz band	106
5.3.3 5.47-5.725 GHz band	111
5.3.4 5.725-5.85 GHz band	126

1 Attestation of Test Results



















1.1 Description of EUT

The equipment under test was a single board computer with *Bluetooth*, 2.4 GHz WLAN and 5 GHz WLAN transceivers.

1.2 General Information

Specification Reference:	47CFR15.407 and 47CFR15.403
Specification Title:	Code of Federal Regulations Volume 47 (Telecommunications): Part 15 Subpart E (Unlicensed National Information Infrastructure Devices) – Sections 15.403 and 15.407
Specification Reference:	47CFR15.209
Specification Title:	Code of Federal Regulations Volume 47 (Telecommunications): Part 15 Subpart C (Intentional Radiators) - Section 15.209
Specification Reference:	RSS-Gen Issue 5 February 2021
Specification Title:	General Requirements for Compliance of Radio Apparatus
Specification Reference:	RSS-247 Issue 2 February 2017
Specification Title:	Digital Transmission Systems (DTs), Frequency Hopping Systems (FHSs) and Licence-Exempt Local Area Network (LE-LAN) Devices
Site Registration:	FCC: 685609, ISEDC: 20903
FCC Lab. Designation No.:	UK2011
ISEDC CABID:	UK0001
Location of Testing:	Unit 3 Horizon, Wade Road, Kingsland Business Park, Basingstoke, Hampshire, G24 8AH, United Kingdom
Test Dates:	16 May 2023 to 08 August 2023

1.3 Summary of Test Results

FCC Reference (47CFR)	ISED Canada Reference	Measurement	Result
Part 15.35(c)	RSS-Gen 8.2	Transmitter Duty Cycle	Note 1
N/A	RSS-Gen 6.7 / RSS-247 6.2	Transmitter 99% Occupied Bandwidth	
Part 15.403(i)	N/A	Transmitter 26 dB Emission Bandwidth	
Part 15.407(e)	RSS-247 6.2.4.1	Transmitter Minimum 6 dB Bandwidth (5.725-5.85 GHz band)	
Part 15.407(a)(1)(iv)	N/A	Transmitter Maximum Conducted Output Power (5.15-5.25 GHz band)	
N/A	RSS-Gen 6.12 / RSS-247 6.2.1.1	Transmitter Maximum Equivalent Isotropically Radiated Power (EIRP) (5.15-5.25 GHz band)	
Part 15.407(a)(2)	RSS-Gen 6.12 / RSS-247 6.2.2.1	Transmitter Maximum Conducted Output Power (5.25-5.35 GHz band)	
N/A	RSS-Gen 6.12 / RSS-247 6.2.2.1	Transmitter Maximum Equivalent Isotropically Radiated Power (EIRP) (5.25-5.35 GHz band)	
Part 15.407(a)(2)	RSS-Gen 6.12 / RSS-247 6.2.3.1	Transmitter Maximum Conducted Output Power (5.47-5.725 GHz band)	
N/A	RSS-Gen 6.12 / RSS-247 6.2.3.1	Transmitter Maximum Equivalent Isotropically Radiated Power (EIRP) (5.47-5.725 GHz band)	
Part 15.407(a)(3)	RSS-Gen 6.12 / RSS-247 6.2.4.1	Transmitter Maximum Conducted Output Power (5.725-5.85 GHz band)	
Part 15.407(a)(1)(iv)	N/A	Transmitter Maximum Power Spectral Density (5.15-5.25 GHz band)	
N/A	RSS-Gen 6.12 / RSS-247 6.2.1.1	Transmitter EIRP Spectral Density (5.15-5.25 GHz band)	
Part 15.407(a)(2)	RSS-Gen 6.12 / RSS-247 6.2.2.1	Transmitter Power Spectral Density (5.25-5.35 GHz band)	
Part 15.407(a)(2)	RSS-Gen 6.12 / RSS-247 6.2.3.1	Transmitter Power Spectral Density (5.47-5.725 GHz band)	
Part 15.407(a)(3)	RSS-Gen 6.12 / RSS-247 6.2.4.1	Transmitter Maximum Power Spectral Density (5.725-5.85 GHz band)	
Part 15.407(b) / 15.209(a)	RSS-Gen 6.13 & 8.9 / RSS-247 6.2.1.2, 6.2.2.2, 6.2.3.2 & 6.2.4.2	Transmitter Out of Band Radiated Emissions	
Part 15.407(b) / 15.209(a)	RSS-Gen 6.13, 8.9 & 8.10 / RSS-247 6.2.1.2, 6.2.2.2, 6.2.3.2 & 6.2.4.2	Transmitter Band Edge Radiated Emissions	
Part 15.407(g)	RSS-Gen 6.11	Transmitter Frequency Stability (Temperature & Voltage Variation)	Note 2
Part 15.407(h)(1)	RSS-247 6.2	Transmitter Power Control	Note 3
Key to Results			
 = Complied  = Did not comply			

Note(s):

1. The measurement was performed to assist in the calculation of the level of average output power, power spectral density and emissions as the EUT employs pulsed operation.
2. The frequency stability is sufficient to ensure that the signal remains in the allocated bands under all operational conditions, as stated in the user manual.
3. Transmit Power Control was not tested as the maximum EIRP is less than 500 mW (27 dBm).

1.4 Deviations from the Test Specification

For the measurements contained within this test report, there were no deviations from, additions to, or exclusions from the test specifications identified above.

2 Summary of Testing

2.1 Facilities and Accreditation

The test site and measurement facilities used to collect data are located at Unit 3 Horizon, Wade Road, Kingsland Business Park, Basingstoke, Hampshire, RG24 8AH, United Kingdom. The following table identifies which facilities were utilised for radiated emission measurements documented in this report. Specific facilities are also identified in the test results sections.

Site 1	X
Site 2	
Site 17	X

UL International (UK) Ltd is accredited by the United Kingdom Accreditation Service (UKAS). UKAS is one of the signatories to the International Laboratory Accreditation Co-operation (ILAC) Arrangement for the mutual recognition of test reports. The tests reported herein have been performed in accordance with its terms of accreditation.

2.2 Methods and Procedures

Reference:	ANSI C63.10-2013
Title:	American National Standard of Procedures for Compliance Testing of Unlicensed Wireless Devices
Reference:	KDB 789033 D02 General U-NII Test Procedures New Rules v02r01 December 14, 2017
Title:	Guidelines for Compliance Testing of Unlicensed National Information Infrastructure (U-NII) Devices (Part 15, Subpart E)

2.3 Calibration and Uncertainty

Measuring Instrument Calibration

In accordance with UKAS requirements all the measurement equipment is on a calibration schedule. All equipment was within the calibration period on the date of testing.

Measurement Uncertainty & Decision Rule

Overview

No measurement or test can ever be perfect and the imperfections give rise to error of measurement in the results. Consequently the result of a measurement is only an approximation to the value of the measurand (the specific quantity subject to measurement) and is only complete when accompanied by a statement of the uncertainty of the approximation.

The expression of uncertainty of a measurement result allows realistic comparison of results with reference values and limits given in specifications and standards.

Decision Rule

Measurement system instrumentation shall be used with an accuracy specification meeting the accuracy specification limits according to IEC/IECEE OD-5014.

As applicable, unless specified otherwise in the quotation, the compliance "Decision Rule" is based on Simple Acceptance. If the measured value is on the limit, the result is defined as a pass. In this case the risk of a false positive is 50%. For further information regarding risk assessment refer to ILAC G8:09/2019.

Measurement Uncertainty

The reported expanded uncertainties below are based on a standard uncertainty multiplied by an appropriate coverage factor such that a confidence level of approximately 95% is maintained. For the purposes of this document "approximately" is interpreted as meaning "effectively" or "for most practical purposes".

Measurement Type	Range	Confidence Level (%)	Calculated Uncertainty
Duty Cycle	5.15 GHz to 5.850 GHz	95%	±1.39 %
99% Emission Bandwidth	5.15 GHz to 5.850 GHz	95%	±3.92 %
26 dB Emission Bandwidth	5.15 GHz to 5.850 GHz	95%	±4.59 %
Minimum 6 dB Emission Bandwidth	5.15 GHz to 5.850 GHz	95%	±4.59 %
Maximum Conducted Output Power (Fast Power Sensor)	5.15 GHz to 5.850 GHz	95%	±0.58 dB
Maximum Conducted Output Power (Spectrum Analyser)	5.15 GHz to 5.850 GHz	95%	±1.13 dB
Maximum Power Spectral Density	5.15 GHz to 5.850 GHz	95%	±1.13 dB
Radiated Spurious Emissions	9 kHz to 30 MHz	95%	±5.32 dB
Radiated Spurious Emissions	30 MHz to 1 GHz	95%	±3.30 dB
Radiated Spurious Emissions	1 GHz to 40 GHz	95%	±3.16 dB

The methods used to calculate the above uncertainties are in line with those recommended within the various measurement specifications. Where measurement specifications do not include guidelines for the evaluation of measurement uncertainty the published guidance of the appropriate accreditation body is followed.

2.4 Test and Measurement Equipment

Test Equipment Used for Transmitter Conducted Tests

Asset No.	Instrument	Manufacturer	Type No.	Serial No.	Date Calibration Due	Cal. Interval (Months)
M2071	Thermohygrometer	Testo	608-H1	45258132	08 Dec 2023	12
M231908	Signal Analyser	Keysight	N9020B	MY63430180	20 Dec 2023	12
A220120	Attenuator	Pasternack	PE7013-10	#1	Calibrated before use	-
M215596	Power Sensor	Boonton	RTP5008	11819	24 Mar 2024	12
231995	Switching Unit	Mini-Circuits	ZT-400	12211020020	Calibrated before use	-
E235134	Environmental Chamber	Espec	PU-1J	15020642	Calibrated before use	-
M226925	Thermometer	Fluke	52II	51980008WS	25 Oct 2023	12
M1725	Network Analyser	Keysight	E5071C	MY46316169	09 Nov 2023	12

Test Measurement Software/Firmware Used

Name	Version	Release Date
Phoenix	1.2.12	02/08/2023

Test and Measurement Equipment (continued)**Test Equipment Used for Transmitter Radiated Emissions**

Asset No.	Instrument	Manufacturer	Type No.	Serial No.	Date Calibration Due	Cal. Interval (Months)
K0017	3m RSE Chamber	MVG Industries UK Ltd.	N/A	N/A	08 Nov 2023	12
M2003	Thermohygrometer	Testo	608-H1	45046641	09 Dec 2023	12
M1995	Test Receiver	Rohde & Schwarz	ESU40	100428	02 Nov 2023	12
A2916	Attenuator	AtlanTecRF	AN18W5-10	832827#2	25 Jan 2024	12
A2889	Horn Antenna	Schwarzbeck	BBHA 9120 B	00653	02 Nov 2023	12
A2890	Horn Antenna	Schwarzbeck	HWRD 750	014	02 Nov 2023	12
A212038	High Pass Filter	Micro-Tronics	HPS20723	004	25 Jan 2024	12
A223628	Pre-Amplifier	Atlantic Microwave	A-LNAKX-380116-S5S5	210837001	03 Nov 2023	12
A3036	Low Pass Filter	AtlanTecRF	AFL-02000	15062902848	25 Jan 2024	12
A3167	Pre-Amplifier	Com-Power	PAM-103	18020010	02 Nov 2023	12
A2148	Attenuator	Atlan TecRF	AN18-06	090202-06	06 Oct 2023	12
A490	Bi-Log Antenna	Chase EMC Ltd	CBL6111A	1590	06 Oct 2023	12
A2863	Pre-Amplifier	Keysight Technologies Inc	8449B	3008A02100	07 Nov 2023	12
A2892	Horn Antenna	Schwarzbeck	BBHA 9170	9170-727	31 Oct 2023	12
A3265	Pre-Amplifier	Schwarzbeck	BBV 9721	9721-069	31 Oct 2023	12
K0001	3m RSE Chamber	MVG Industries UK Ltd.	N/A	N/A	05 Sep 2023	12
M2040	Thermohygrometer	Testo	608-H1	45124934	09 Dec 2023	12
M236226	Test Receiver	Rohde & Schwarz	ESW26	103134	21 Apr 2024	12
A3165	Loop Antenna	ETS-Lindgren	6502	00224383	13 Apr 2024	12

Test and Measurement Equipment (continued)**Test Equipment Used for Transmitter Band Edge Radiated Emissions**

Asset No.	Instrument	Manufacturer	Type No.	Serial No.	Date Calibration Due	Cal. Interval (Months)
K0017	3m RSE Chamber	MVG Industries UK Ltd.	N/A	N/A	08 Nov 2023	12
M2003	Thermohygrometer	Testo	608-H1	45046641	09 Dec 2023	12
M1995	Test Receiver	Rohde & Schwarz	ESU40	100428	02 Nov 2023	12
A2916	Attenuator	AtlanTecRF	AN18W5-10	832827#2	25 Jan 2024	12
A2889	Horn Antenna	Schwarzbeck	BBHA 9120 B	00653	02 Nov 2023	12
A2863	Pre-Amplifier	Keysight Technologies Inc	8449B	3008A02100	07 Nov 2023	12
K0001	3m RSE Chamber	MVG Industries UK Ltd.	N/A	N/A	05 Sep 2023	12
M2040	Thermohygrometer	Testo	608-H1	45124934	09 Dec 2023	12
M1874	Test Receiver	Rohde & Schwarz	ESU26	100553	19 May 2023	12
A2523	Attenuator	AtlanTecRF	AN18W5-10	832827#1	26 Jan 2024	12
A222867	Pre-Amplifier	Atlantic Microwave	A-LNAKX-380116-S5S5	220705002	26 Aug 2023	12
A3138	Horn Antenna	Schwarzbeck	BBHA 9120 B	00702	22 Aug 2023	12

3 Equipment Under Test (EUT)

3.1 Identification of Equipment Under Test (EUT)

Brand Name:	Raspberry Pi
Model Name or Number / HVIN:	V2.0
PMN:	Raspberry Pi 5
Test Sample Serial Number:	C9 (<i>Conducted sample #1</i>)
Hardware Version:	V2.0
Software Version:	V1.0
FCC ID:	2ABCB-RPI5
ISED Canada Certification Number:	IC: 20953-RPI5
Date of Receipt:	18 May 2023

Brand Name:	Raspberry Pi
Model Name or Number / HVIN:	V2.0
PMN:	Raspberry Pi 5
Test Sample Serial Number:	R29 (<i>Radiated sample #1</i>)
Hardware Version:	V2.0
Software Version:	V1.0
FCC ID:	2ABCB-RPI5
ISED Canada Certification Number:	IC: 20953-RPI5
Date of Receipt:	17 May 2023

3.2 Modifications Incorporated in the EUT

No modifications were applied to the EUT during testing.

3.3 Additional Information Related to Testing

Technology Tested:	WLAN (IEEE 802.11a,n,ac) / U-NII	
Type of Unit:	Transceiver	
Modulation:	BPSK, QPSK, 16QAM, 64QAM & 256QAM	
Data rates:	802.11a	6, 9, 12, 18, 24, 36, 48 & 54 Mbps
	802.11n HT20	MCS0 to MCS7 (SISO)
	802.11n HT40	MCS0 to MCS7 (SISO)
	802.11ac VHT20	MCS0 to MCS8 (SISO)
	802.11ac VHT40	MCS0 to MCS9 (SISO)
	802.11ac VHT80	MCS0 to MCS9 (SISO)
Power Supply Requirement(s):	Nominal	5.1 VDC via 120 VAC 60 Hz adaptor
Maximum Conducted Output Power:	20 MHz	14.7 dBm
	40 MHz	14.4 dBm
	80 MHz	14.6 dBm

Additional Information Related to Testing (continued)

Channel Spacing:	20 MHz		
Transmit Frequency Band:	5150 MHz to 5250 MHz		
Transmit Channels Tested:	Channel ID	Channel Number	Channel Frequency (MHz)
	Bottom	36	5180
	Middle	40	5200
	Top	48	5240
Transmit Frequency Band:	5250 MHz to 5350 MHz		
Transmit Channels Tested:	Channel ID	Channel Number	Channel Frequency (MHz)
	Bottom	52	5260
	Middle	56	5280
	Top	64	5320
Transmit Frequency Band:	5470 MHz to 5725 MHz		
Transmit Channels Tested:	Channel ID	Channel Number	Channel Frequency (MHz)
	Bottom	100	5500
	Middle	116	5580
	Top	140	5700
Transmit Frequency Band:	Channels that straddle the U-NII-2C and U-NII-3 bands at 5725 MHz		
Transmit Channel Tested:	Channel ID	Channel Number	Channel Frequency (MHz)
	Single	144	5720
Transmit Frequency Band:	5725 MHz to 5850 MHz		
Transmit Channels Tested:	Channel ID	Channel Number	Channel Frequency (MHz)
	Bottom	149	5745
	Middle	157	5785
	Top	165	5825

Additional Information Related to Testing (continued)

Channel Spacing:	40 MHz		
Transmit Frequency Band:	5150 MHz to 5250 MHz		
Transmit Channels Tested:	Channel ID	Channel Number	Channel Frequency (MHz)
	Bottom	38	5190
	Top	46	5230
Transmit Frequency Band:	5250 MHz to 5350 MHz		
Transmit Channels Tested:	Channel ID	Channel Number	Channel Frequency (MHz)
	Bottom	54	5270
	Top	62	5310
Transmit Frequency Band:	5470 MHz to 5725 MHz		
Transmit Channels Tested:	Channel ID	Channel Number	Channel Frequency (MHz)
	Bottom	102	5510
	Middle	110	5550
	Top	134	5670
Transmit Frequency Band:	Channels that straddle the U-NII-2C and U-NII-3 bands at 5725 MHz		
Transmit Channel Tested:	Channel ID	Channel Number	Channel Frequency (MHz)
	Single	142	5710
Transmit Frequency Band:	5725 MHz to 5850 MHz		
Transmit Channels Tested:	Channel ID	Channel Number	Channel Frequency (MHz)
	Bottom	151	5755
	Top	159	5795

Additional Information Related to Testing (continued)

Channel Spacing:	80 MHz		
Transmit Frequency Band:	5150 MHz to 5250 MHz		
Transmit Channels Tested:	Channel ID	Channel Number	Channel Frequency (MHz)
	Single	42	5210
Transmit Frequency Band:	5250 MHz to 5350 MHz		
Transmit Channels Tested:	Channel ID	Channel Number	Channel Frequency (MHz)
	Single	58	5290
Transmit Frequency Band:	5470 MHz to 5725 MHz		
Transmit Channels Tested:	Channel ID	Channel Number	Channel Frequency (MHz)
	Bottom	106	5530
	Top	122	5610
Transmit Frequency Band:	Channels that straddle the U-NII-2C and U-NII-3 bands at 5725 MHz		
Transmit Channel Tested:	Channel ID	Channel Number	Channel Frequency (MHz)
	Single	138	5690
Transmit Frequency Band:	5725 MHz to 5850 MHz		
Transmit Channels Tested:	Channel ID	Channel Number	Channel Frequency (MHz)
	Single	155	5775

3.4 Description of Available Antennas

The radio utilizes an integrated antenna, with the following maximum gain:

Frequency Range (MHz)	Antenna Gain (dBi)
5150 to 5850	2.5

3.5 Description of Test Setup

Support Equipment

The following support equipment was used to exercise the EUT during testing:

Description:	AC to DC USB-C Power Supply
Brand Name:	Raspberry Pi
Model Name or Number:	KSA-15E-051300HK
Serial Number:	Not Marked or Stated

Description:	Docking Station
Brand Name:	Lenovo
Model Name or Number:	40AT
Serial Number:	ZAFOLGYW

Description:	USB-A Cables. Qty 4. 1.5m
Brand Name:	Not Marked or Stated
Model Name or Number:	Not Marked or Stated
Serial Number:	Not Marked or Stated

Description:	Mini HDMI to HDMI Cables. Qty 2. 1.5m
Brand Name:	Raspberry Pi
Model Name or Number:	Not Marked or Stated
Serial Number:	Not Marked or Stated

Description:	Ethernet Cable. 3m
Brand Name:	Not Marked or Stated
Model Name or Number:	Not Marked or Stated
Serial Number:	Not Marked or Stated

Description:	Laptop
Brand Name:	Lenovo
Model Name or Number:	L480
Serial Number:	PF1EJ3BY

Operating Modes

The EUT was tested in the following operating mode(s):

- Continuously transmitting with a modulated carrier at maximum power on the bottom, middle and top channels as required using the supported data rates/modulation types.

Configuration and Peripherals

The EUT was tested in the following configuration(s):

- The customer's test application and supplied instructions were used to place the EUT into WLAN test mode. The supplied commands were entered into the console menu on the EUT. Test commands stated in text file located on the /home/pi drive of the EUT were used to configure the EUT to enable a continuous transmission and to select the test channels and data rate as required.
- The customer supplied a U.FL RF cable with the EUT in order to perform conducted measurements. The additional path loss was included in any path loss calculations.
- The EUT was powered from an AC to DC USB-C Power Supply. The input was connected to a 120 VAC 60 Hz single phase mains supply.
- The customer declared the following data rates to be used for all measurements.
 - 802.11a SISO - BPSK / 6 Mbps
 - 802.11n HT20 / SISO – BPSK / MCS0
 - 802.11n HT40 / SISO – BPSK / MCS0
 - 802.11ac VHT80 / SISO – BPSK / MCS0
- Transmitter radiated spurious emissions tests were performed with the EUT in the worst-case orientation with respect to emissions. The Ethernet port was terminated into a test laptop via an Ethernet cable. The test laptop was placed in the antechamber. The 2 HDMI ports and 4 USB ports were terminated into a docking station via HDMI and USB cables. The docking station was placed under the turntable.

Test Setup Diagrams

Conducted Tests:

Test Setup for Transmitter Duty Cycle Conducted Tests

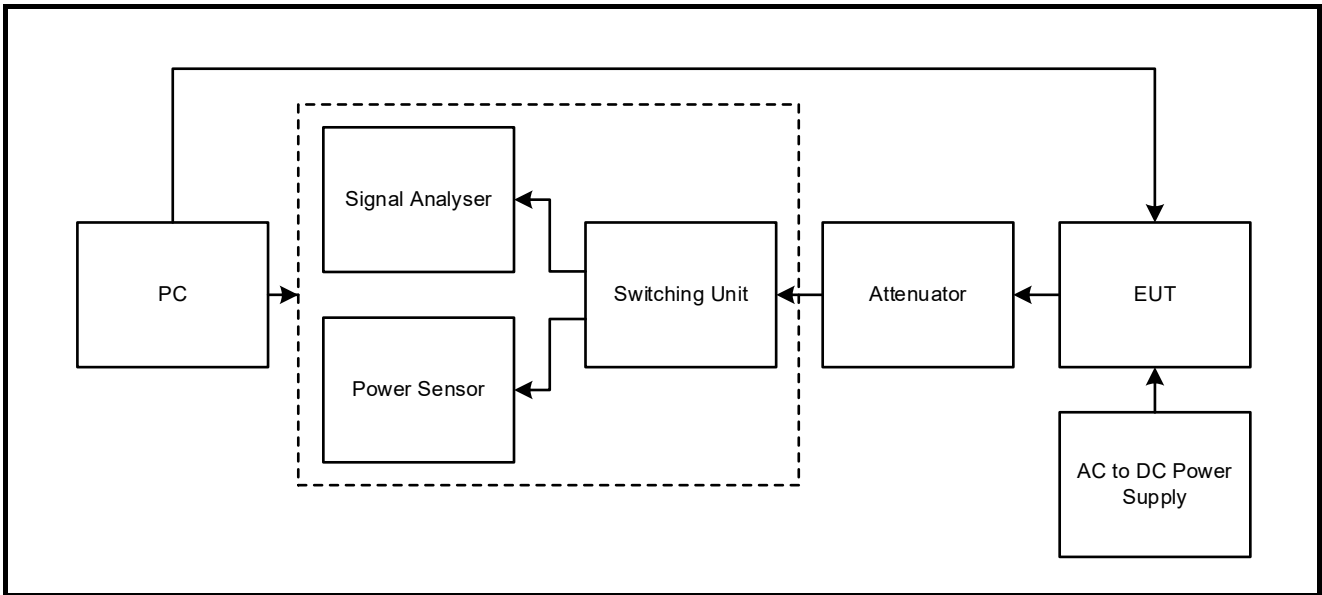

Radiated Tests:

Test Setup for Transmitter Radiated Emissions

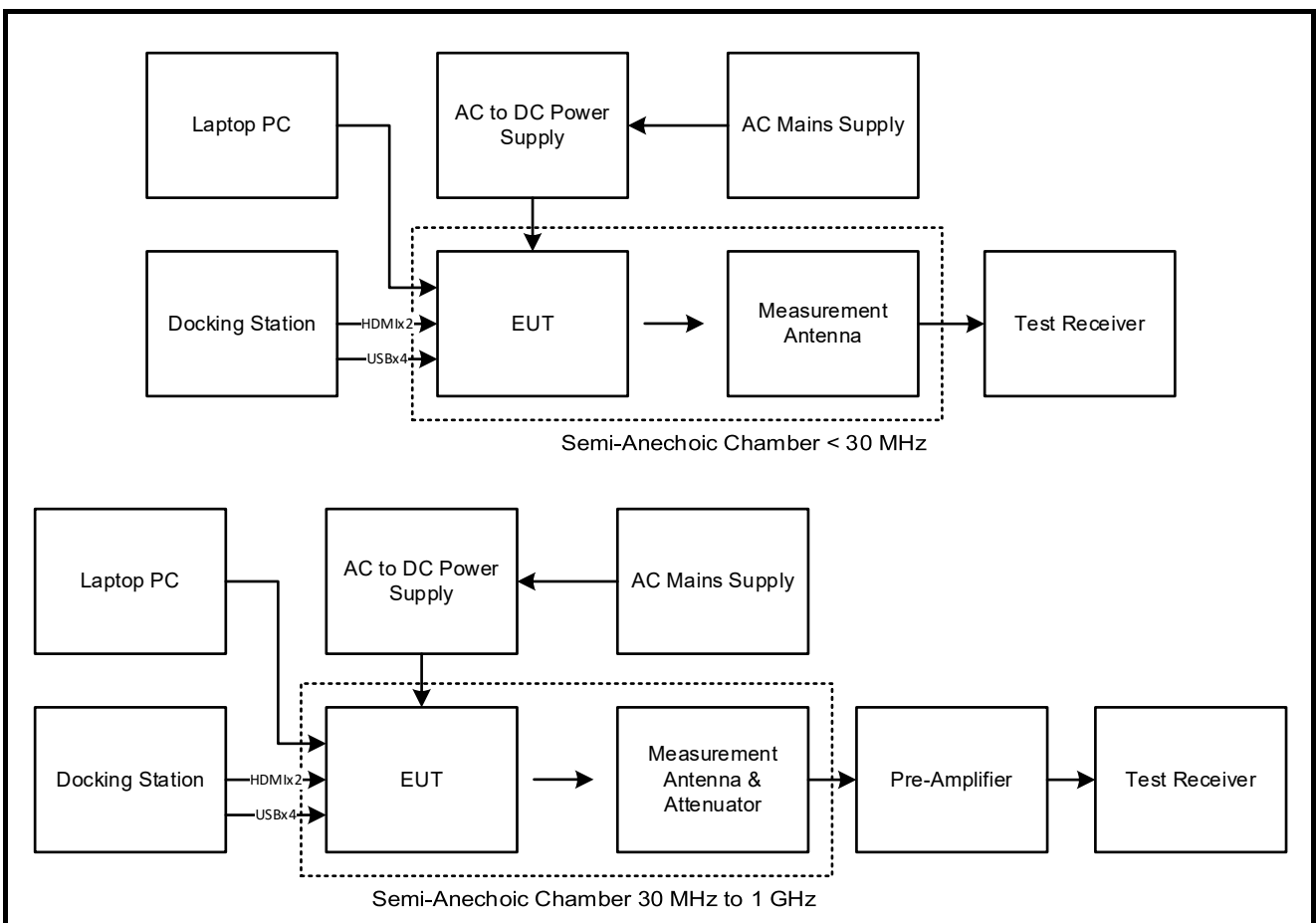

Test Setup for Transmitter Radiated Emissions (continued)

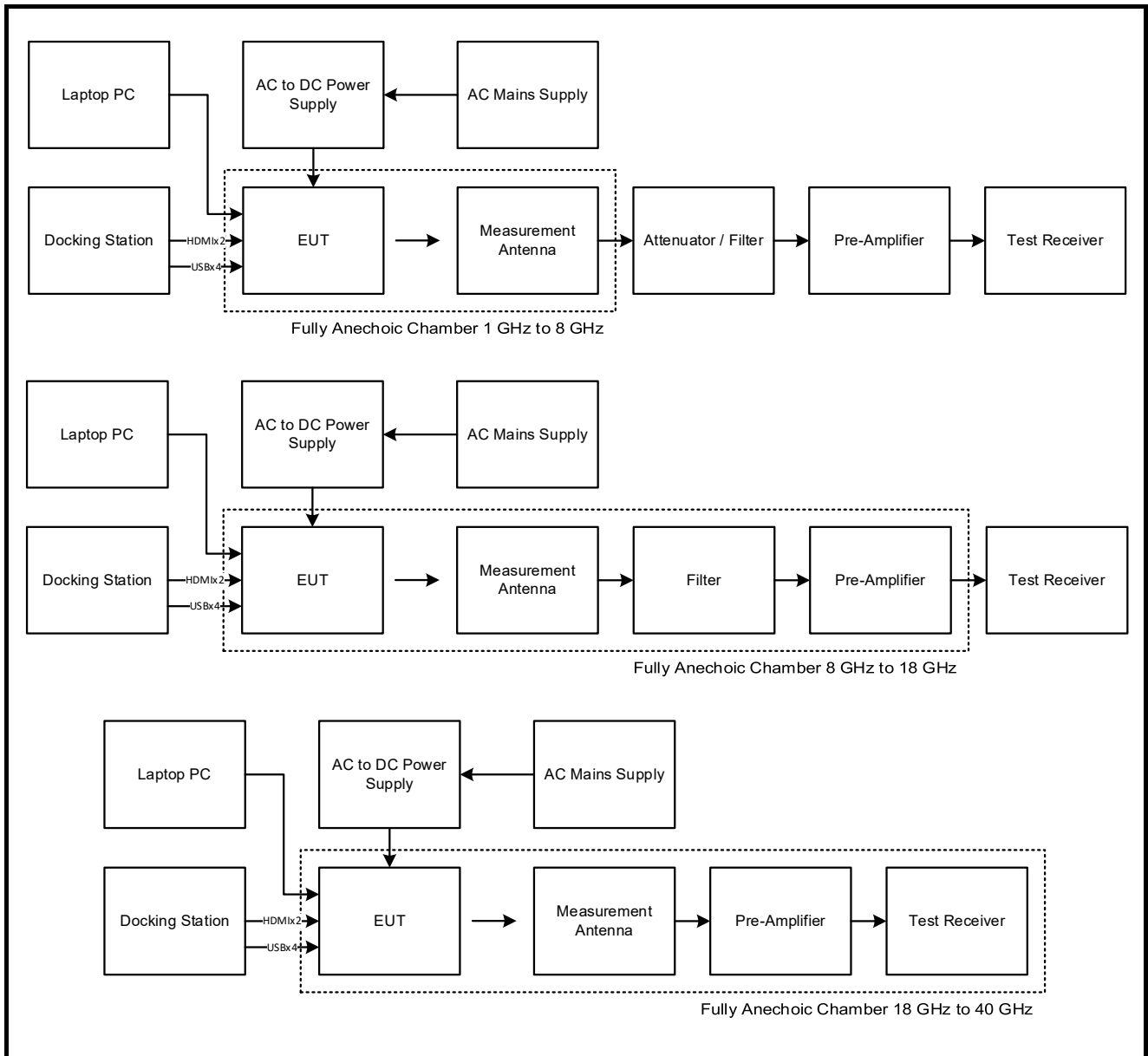

4 Antenna Port Test Results

4.1 Transmitter 26 dB and 99% Emission Bandwidth

Test Summary:

Test Engineer:	Luis Pazos Perez	Test Date:	08 August 2023
Test Sample Serial Number:	C9		

Environmental Conditions:

Temperature (°C):	23
Relative Humidity (%):	50

Note(s):

1. 26 dB Emission Bandwidth measurements were performed in accordance with ANSI C63.10 Section 12.4.1. 99% Occupied Bandwidth measurements were performed in accordance with ANSI C63.10 Section 12.4.2.
2. The signal analyser was connected to the RF port on the EUT using an RF switch, suitable attenuation and RF cables. An RF level offset was entered on the signal analyser to compensate for the loss of the switch, attenuators and RF cables.

Transmitter 26 dB & 99% Emission Bandwidth (5.15-5.25 GHz band) (continued)

4.1.1 5.15-5.25 GHz band

Frequency Range:	5.150-5.250 GHz	Band:	U-NII-1
Limit Clause:	15.407(e) RSS-247 6.2.4.1	Test Method:	C63.10 6.9.3 C63.10 12.4.1

Antenna Configuration:	SISO	Mode:	802.11a
Test Port:	1 (SP1-C0)	Modulation/Rate:	6 Mbps (BPSK)

Test Frequency (MHz)	26 dB Bandwidth (MHz)				Limit (kHz)
	1	2	3	4	
5180 (CH36)	21.300	-	-	-	-
5200 (CH40)	21.360	-	-	-	-
5240 (CH48)	21.360	-	-	-	-

Test Frequency (MHz)	99% Bandwidth (MHz)				Limit (kHz)
	1	2	3	4	
5180 (CH36)	16.680	-	-	-	-
5200 (CH40)	16.680	-	-	-	-
5240 (CH48)	16.740	-	-	-	-

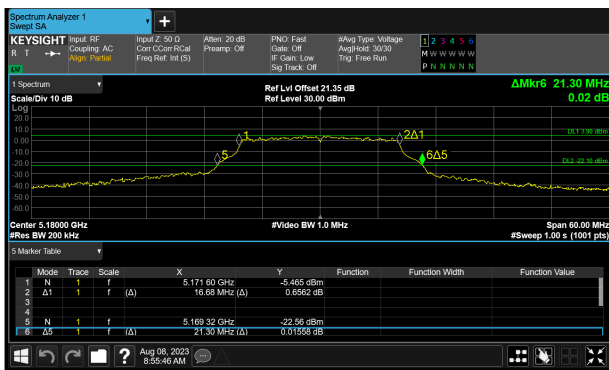

SP1-C0 (1) 5180 MHz (CH36) 26 dB and 99% Bandwidth

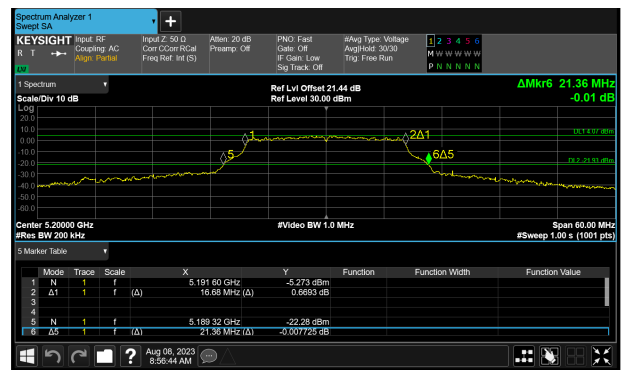

SP1-C0 (1) 5200 MHz (CH40) 26 dB and 99% Bandwidth

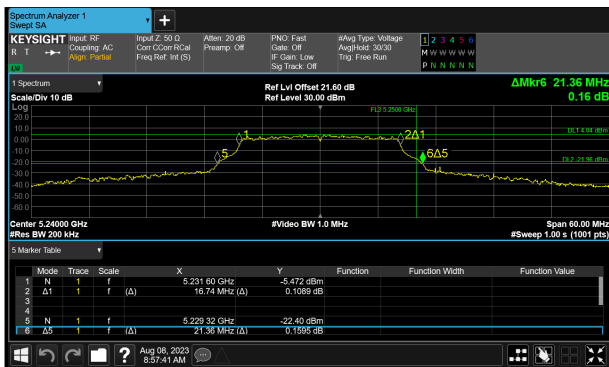

SP1-C0 (1) 5240 MHz (CH48) 26 dB and 99% Bandwidth

Transmitter 26 dB & 99% Emission Bandwidth (5.15-5.25 GHz band) (continued)

Frequency Range:	5.150-5.250 GHz	Band:	U-NII-1
Limit Clause:	15.407(e) RSS-247 6.2.4.1	Test Method:	C63.10 6.9.3 C63.10 12.4.1

Antenna Configuration:	SISO	Mode:	802.11n HT20
Test Port:	1 (SP1-C0)	Modulation/Rate:	MCS0 (BPSK)

Test Frequency (MHz)	26 dB Bandwidth (MHz)				Limit (kHz)
	1	2	3	4	
5180 (CH36)	21.780	-	-	-	-
5200 (CH40)	21.840	-	-	-	-
5240 (CH48)	21.780	-	-	-	-

Test Frequency (MHz)	99% Bandwidth (MHz)				Limit (kHz)
	1	2	3	4	
5180 (CH36)	17.880	-	-	-	-
5200 (CH40)	17.940	-	-	-	-
5240 (CH48)	17.940	-	-	-	-

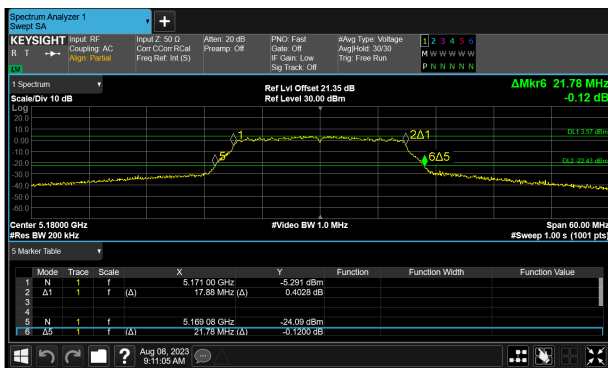

SP1-C0 (1) 5180 MHz (CH36) 26 dB and 99% Bandwidth

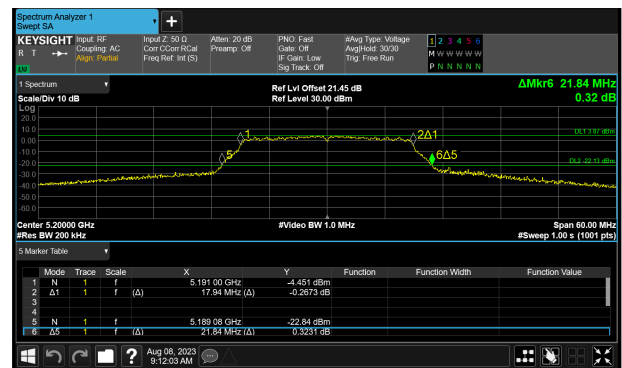

SP1-C0 (1) 5200 MHz (CH40) 26 dB and 99% Bandwidth

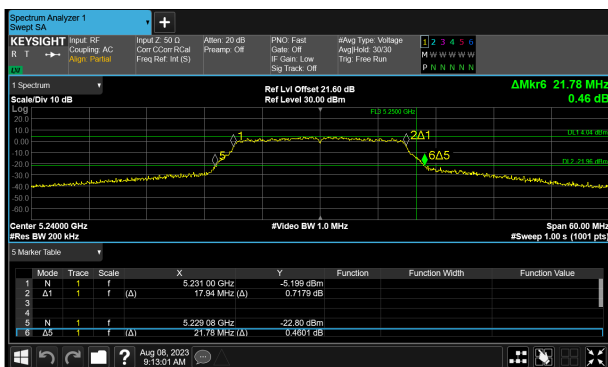

SP1-C0 (1) 5240 MHz (CH48) 26 dB and 99% Bandwidth

Transmitter 26 dB & 99% Emission Bandwidth (5.15-5.25 GHz band) (continued)

Frequency Range:	5.150-5.250 GHz	Band:	U-NII-1
Limit Clause:	15.407(e) RSS-247 6.2.4.1	Test Method:	C63.10 6.9.3 C63.10 12.4.1

Antenna Configuration:	SISO	Mode:	802.11n HT40
Test Port:	1 (SP1-C0)	Modulation/Rate:	MCS0 (BPSK)

Test Frequency (MHz)	26 dB Bandwidth (MHz)				Limit (kHz)
	1	2	3	4	
5190 (CH38)	40.400	-	-	-	-
5230 (CH46)	48.600	-	-	-	-

Test Frequency (MHz)	99% Bandwidth (MHz)				Limit (kHz)
	1	2	3	4	
5190 (CH38)	36.400	-	-	-	-
5230 (CH46)	36.500	-	-	-	-

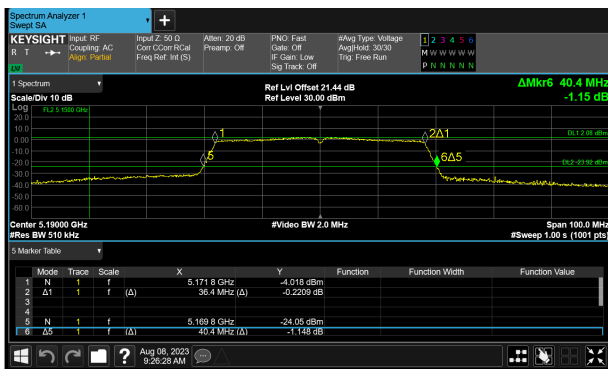

SP1-C0 (1) 5190 MHz (CH38) 26 dB and 99% Bandwidth

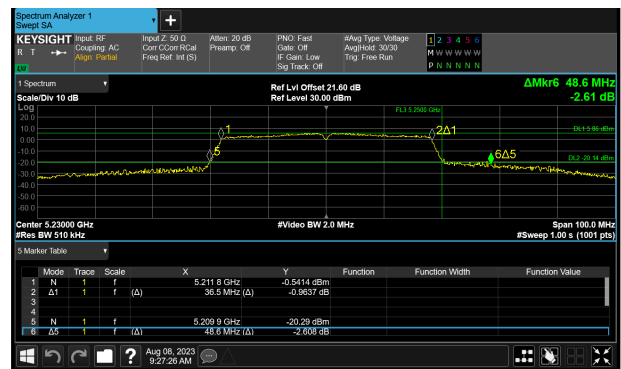

SP1-C0 (1) 5230 MHz (CH46) 26 dB and 99% Bandwidth

Transmitter 26 dB & 99% Emission Bandwidth (5.15-5.25 GHz band) (continued)

Frequency Range:	5.150-5.250 GHz	Band:	U-NII-1
Limit Clause:	15.407(e) RSS-247 6.2.4.1	Test Method:	C63.10 6.9.3 C63.10 12.4.1

Antenna Configuration:	SISO	Mode:	802.11ac VHT80
Test Port:	1 (SP1-C0)	Modulation/Rate:	MCS0x1 (BPSK)

Test Frequency (MHz)	26 dB Bandwidth (MHz)				Limit (kHz)
	1	2	3	4	
5210 (CH42)	82.720	-	-	-	-

Test Frequency (MHz)	99% Bandwidth (MHz)				Limit (kHz)
	1	2	3	4	
5210 (CH42)	75.680	-	-	-	-

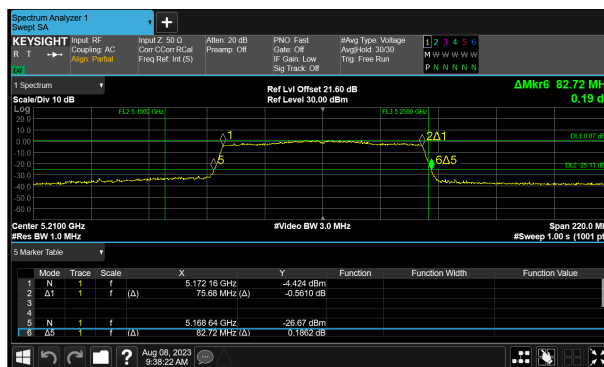

SP1-C0 (1) 5210 MHz (CH42) 26 dB and 99% Bandwidth

Transmitter 26 dB & 99% Emission Bandwidth (5.25-5.35 GHz band) (continued)

4.1.2 5.25-5.35 GHz band

Frequency Range:	5.250-5.350 GHz	Band:	U-NII-2A
Limit Clause:	15.407(e) RSS-247 6.2.4.1	Test Method:	C63.10 6.9.3 C63.10 12.4.1

Antenna Configuration:	SISO	Mode:	802.11a
Test Port:	1 (SP1-C0)	Modulation/Rate:	6 Mbps (BPSK)

Test Frequency (MHz)	26 dB Bandwidth (MHz)				Limit (kHz)
	1	2	3	4	
5260 (CH52)	21.420	-	-	-	-
5280 (CH56)	21.360	-	-	-	-
5320 (CH64)	21.420	-	-	-	-

Test Frequency (MHz)	99% Bandwidth (MHz)				Limit (kHz)
	1	2	3	4	
5260 (CH52)	16.740	-	-	-	-
5280 (CH56)	16.740	-	-	-	-
5320 (CH64)	16.800	-	-	-	-

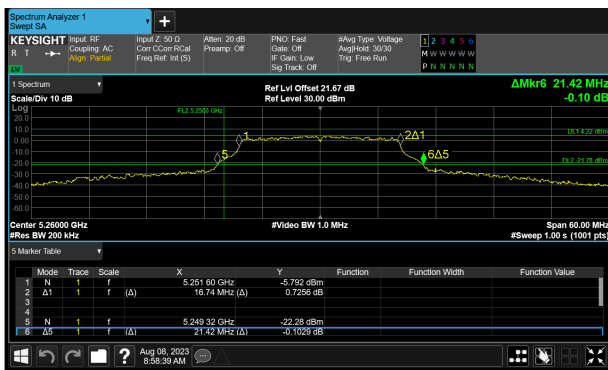

SP1-C0 (1) 5260 MHz (CH52) 26 dB and 99% Bandwidth

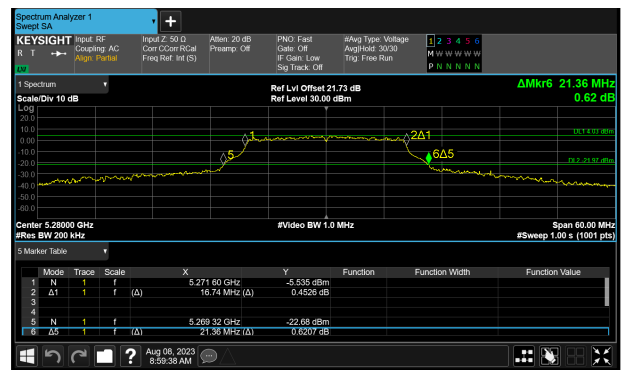

SP1-C0 (1) 5280 MHz (CH56) 26 dB and 99% Bandwidth

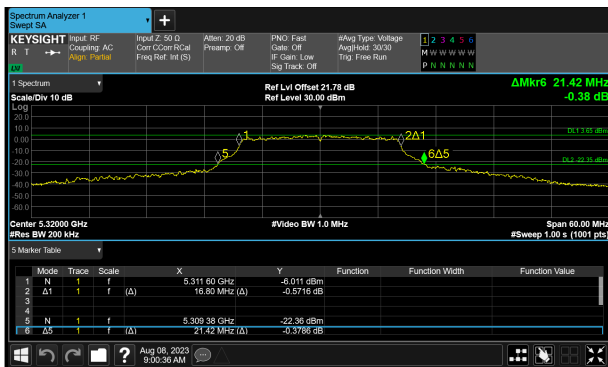

SP1-C0 (1) 5320 MHz (CH64) 26 dB and 99% Bandwidth

Transmitter 26 dB & 99% Emission Bandwidth (5.25-5.35 GHz band) (continued)

Frequency Range:	5.250-5.350 GHz	Band:	U-NII-2A
Limit Clause:	15.407(e) RSS-247 6.2.4.1	Test Method:	C63.10 6.9.3 C63.10 12.4.1

Antenna Configuration:	SISO	Mode:	802.11n HT20
Test Port:	1 (SP1-C0)	Modulation/Rate:	MCS0 (BPSK)

Test Frequency (MHz)	26 dB Bandwidth (MHz)				Limit (kHz)
	1	2	3	4	
5260 (CH52)	21.780	-	-	-	-
5280 (CH56)	23.220	-	-	-	-
5320 (CH64)	23.400	-	-	-	-

Test Frequency (MHz)	99% Bandwidth (MHz)				Limit (kHz)
	1	2	3	4	
5260 (CH52)	18.000	-	-	-	-
5280 (CH56)	18.000	-	-	-	-
5320 (CH64)	18.060	-	-	-	-

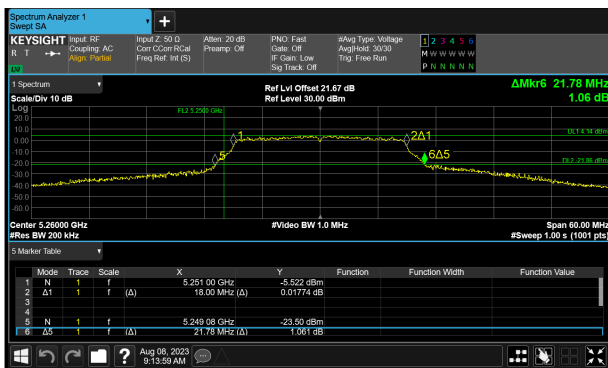

SP1-C0 (1) 5260 MHz (CH52) 26 dB and 99% Bandwidth

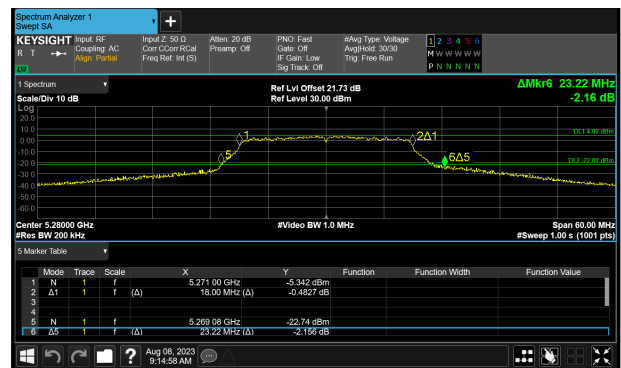

SP1-C0 (1) 5280 MHz (CH56) 26 dB and 99% Bandwidth

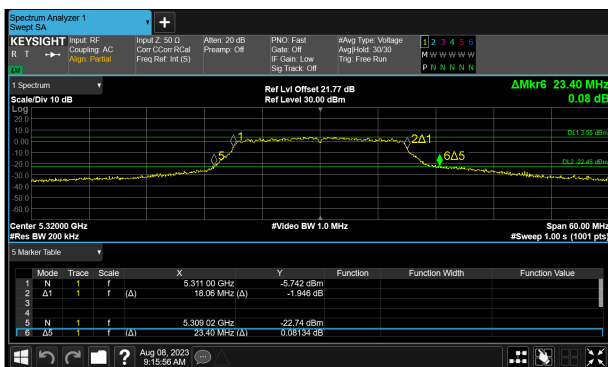

SP1-C0 (1) 5320 MHz (CH64) 26 dB and 99% Bandwidth

Transmitter 26 dB & 99% Emission Bandwidth (5.25-5.35 GHz band) (continued)

Frequency Range:	5.250-5.350 GHz	Band:	U-NII-2A
Limit Clause:	15.407(e) RSS-247 6.2.4.1	Test Method:	C63.10 6.9.3 C63.10 12.4.1

Antenna Configuration:	SISO	Mode:	802.11n HT40
Test Port:	1 (SP1-C0)	Modulation/Rate:	MCS0 (BPSK)

Test Frequency (MHz)	26 dB Bandwidth (MHz)				Limit (kHz)
	1	2	3	4	
5270 (CH54)	48.900	-	-	-	-
5310 (CH62)	40.400	-	-	-	-

Test Frequency (MHz)	99% Bandwidth (MHz)				Limit (kHz)
	1	2	3	4	
5270 (CH54)	36.500	-	-	-	-
5310 (CH62)	36.500	-	-	-	-

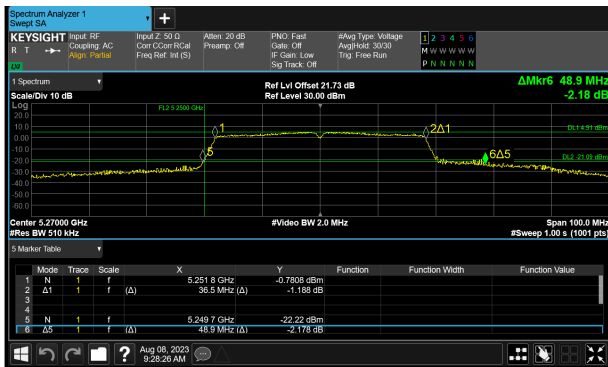

SP1-C0 (1) 5270 MHz (CH54) 26 dB and 99% Bandwidth

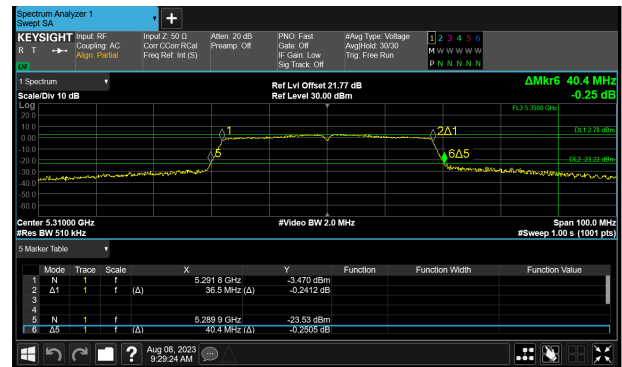

SP1-C0 (1) 5310 MHz (CH62) 26 dB and 99% Bandwidth

Transmitter 26 dB & 99% Emission Bandwidth (5.25-5.35 GHz band) (continued)

Frequency Range:	5.250-5.350 GHz	Band:	U-NII-2A
Limit Clause:	15.407(e) RSS-247 6.2.4.1	Test Method:	C63.10 6.9.3 C63.10 12.4.1

Antenna Configuration:	SISO	Mode:	802.11ac VHT80
Test Port:	1 (SP1-C0)	Modulation/Rate:	MCS0x1 (BPSK)

Test Frequency (MHz)	26 dB Bandwidth (MHz)				Limit (kHz)
	1	2	3	4	
5290 (CH58)	82.720	-	-	-	-

Test Frequency (MHz)	99% Bandwidth (MHz)				Limit (kHz)
	1	2	3	4	
5290 (CH58)	75.900	-	-	-	-



SP1-C0 (1) 5290 MHz (CH58) 26 dB and 99% Bandwidth

Transmitter 26 dB & 99% Emission Bandwidth (5.47-5.725 GHz band) (continued)**4.1.3 5.47-5.725 GHz band**

Frequency Range:	5.470-5.725 GHz	Band:	U-NII-2C
Limit Clause:	15.407(e) RSS-247 6.2.4.1	Test Method:	C63.10 6.9.3 C63.10 12.4.1

Antenna Configuration:	SISO	Mode:	802.11a
Test Port:	1 (SP1-C0)	Modulation/Rate:	6 Mbps (BPSK)

Test Frequency (MHz)	26 dB Bandwidth (MHz)				Limit (kHz)
	1	2	3	4	
5500 (CH100)	21.180	-	-	-	-
5580 (CH116)	21.300	-	-	-	-
5700 (CH140)	21.300	-	-	-	-
5720 (CH144)	16.340	-	-	-	-

Test Frequency (MHz)	99% Bandwidth (MHz)				Limit (kHz)
	1	2	3	4	
5500 (CH100)	16.680	-	-	-	-
5580 (CH116)	16.740	-	-	-	-
5700 (CH140)	16.740	-	-	-	-
5720 (CH144)	13.460	-	-	-	-

Transmitter 26 dB & 99% Emission Bandwidth (5.47-5.725 GHz band) (continued)

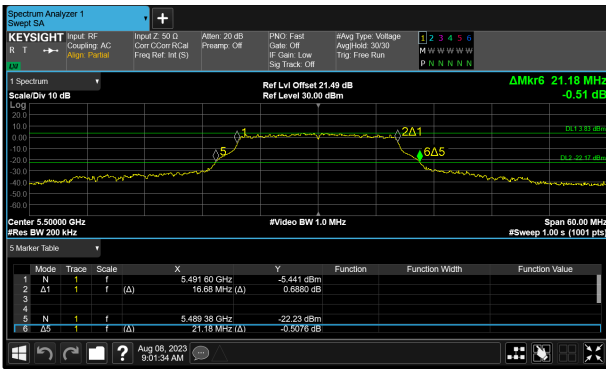

SP1-C0 (1) 5500 MHz (CH100) 26 dB and 99% Bandwidth

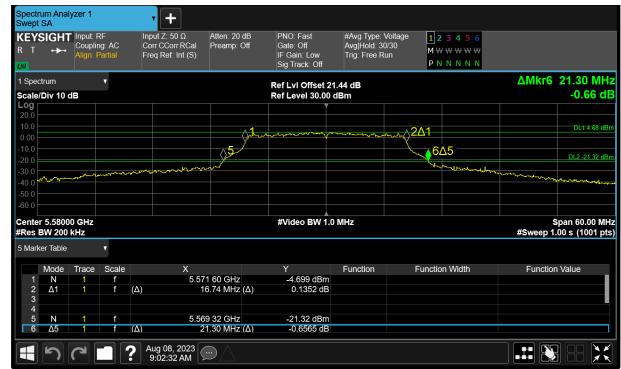

SP1-C0 (1) 5580 MHz (CH116) 26 dB and 99% Bandwidth

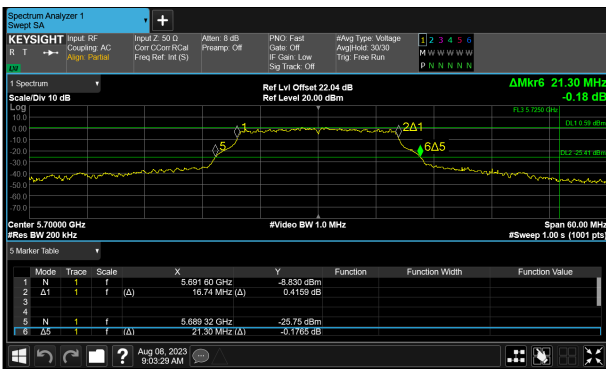

SP1-C0 (1) 5700 MHz (CH140) 26 dB and 99% Bandwidth

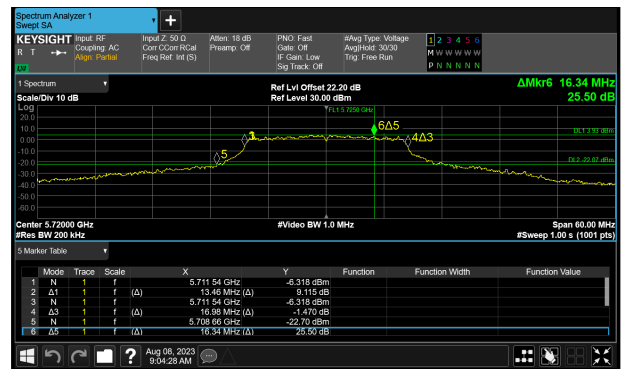

SP1-C0 (1) 5720 MHz (CH144) 26 dB and 99% Bandwidth

Transmitter 26 dB & 99% Emission Bandwidth (5.47-5.725 GHz band) (continued)

Frequency Range:	5.470-5.725 GHz	Band:	U-NII-2C
Limit Clause:	15.407(e) RSS-247 6.2.4.1	Test Method:	C63.10 6.9.3 C63.10 12.4.1

Antenna Configuration:	SISO	Mode:	802.11n HT20
Test Port:	1 (SP1-C0)	Modulation/Rate:	MCS0 (BPSK)

Test Frequency (MHz)	26 dB Bandwidth (MHz)				Limit (kHz)
	1	2	3	4	
5500 (CH100)	21.900	-	-	-	-
5580 (CH116)	22.380	-	-	-	-
5700 (CH140)	21.780	-	-	-	-
5720 (CH144)	17.240	-	-	-	-

Test Frequency (MHz)	99% Bandwidth (MHz)				Limit (kHz)
	1	2	3	4	
5500 (CH100)	17.940	-	-	-	-
5580 (CH116)	17.940	-	-	-	-
5700 (CH140)	17.880	-	-	-	-
5720 (CH144)	14.060	-	-	-	-

Transmitter 26 dB & 99% Emission Bandwidth (5.47-5.725 GHz band) (continued)

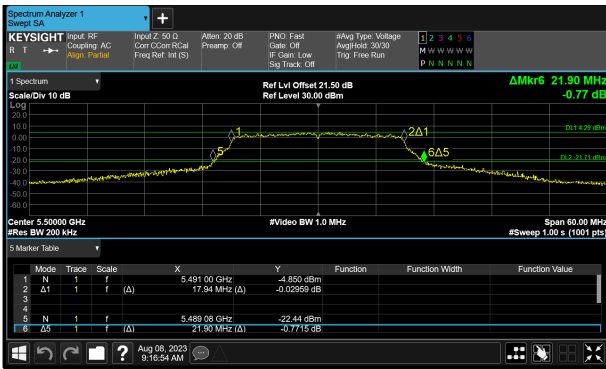

SP1-C0 (1) 5500 MHz (CH100) 26 dB and 99% Bandwidth

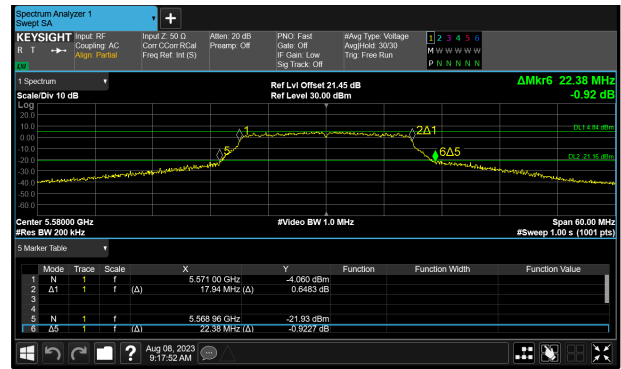

SP1-C0 (1) 5580 MHz (CH116) 26 dB and 99% Bandwidth

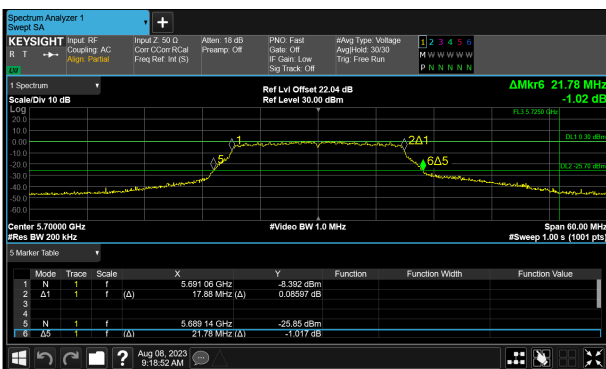

SP1-C0 (1) 5700 MHz (CH140) 26 dB and 99% Bandwidth

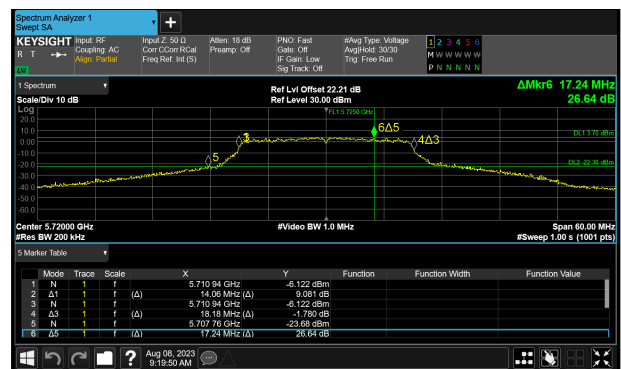

SP1-C0 (1) 5720 MHz (CH144) 26 dB and 99% Bandwidth

Transmitter 26 dB & 99% Emission Bandwidth (5.47-5.725 GHz band) (continued)

Frequency Range:	5.470-5.725 GHz	Band:	U-NII-2C
Limit Clause:	15.407(e) RSS-247 6.2.4.1	Test Method:	C63.10 6.9.3 C63.10 12.4.1

Antenna Configuration:	SISO	Mode:	802.11n HT40
Test Port:	1 (SP1-C0)	Modulation/Rate:	MCS0 (BPSK)

Test Frequency (MHz)	26 dB Bandwidth (MHz)				Limit (kHz)
	1	2	3	4	
5510 (CH102)	40.300	-	-	-	-
5550 (CH110)	48.900	-	-	-	-
5670 (CH134)	58.300	-	-	-	-
5710 (CH142)	41.280	-	-	-	-

Test Frequency (MHz)	99% Bandwidth (MHz)				Limit (kHz)
	1	2	3	4	
5510 (CH102)	36.400	-	-	-	-
5550 (CH110)	36.600	-	-	-	-
5670 (CH134)	36.900	-	-	-	-
5710 (CH142)	33.360	-	-	-	-

Transmitter 26 dB & 99% Emission Bandwidth (5.47-5.725 GHz band) (continued)

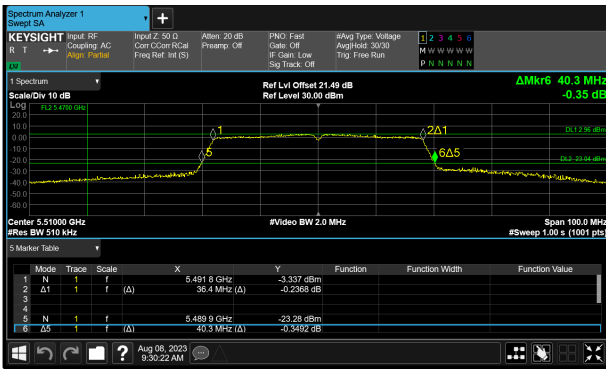

SP1-C0 (1) 5510 MHz (CH102) 26 dB and 99% Bandwidth

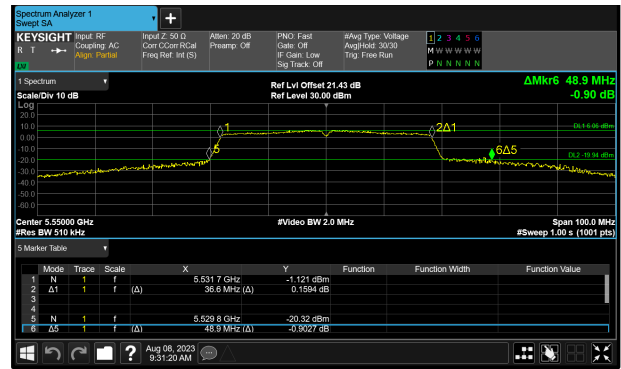

SP1-C0 (1) 5550 MHz (CH110) 26 dB and 99% Bandwidth

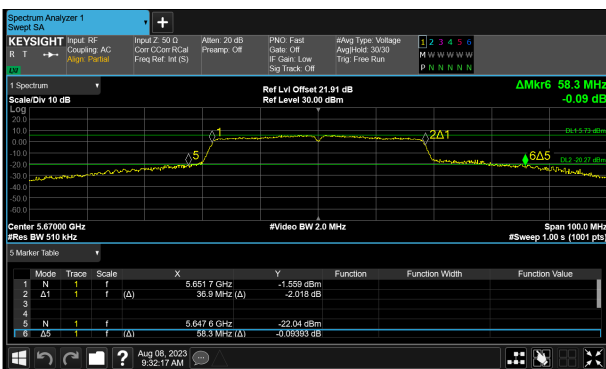

SP1-C0 (1) 5670 MHz (CH134) 26 dB and 99% Bandwidth

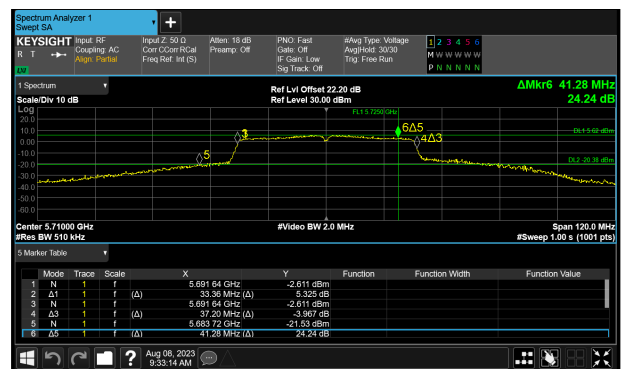

SP1-C0 (1) 5710 MHz (CH142) 26 dB and 99% Bandwidth

Transmitter 26 dB & 99% Emission Bandwidth (5.47-5.725 GHz band) (continued)

Frequency Range:	5.470-5.725 GHz	Band:	U-NII-2C
Limit Clause:	15.407(e) RSS-247 6.2.4.1	Test Method:	C63.10 6.9.3 C63.10 12.4.1

Antenna Configuration:	SISO	Mode:	802.11ac VHT80
Test Port:	1 (SP1-C0)	Modulation/Rate:	MCS0x1 (BPSK)

Test Frequency (MHz)	26 dB Bandwidth (MHz)				Limit (kHz)
	1	2	3	4	
5530 (CH106)	82.280	-	-	-	-
5610 (CH122)	100.540	-	-	-	-
5690 (CH138)	76.280	-	-	-	-

Test Frequency (MHz)	99% Bandwidth (MHz)				Limit (kHz)
	1	2	3	4	
5530 (CH106)	75.680	-	-	-	-
5610 (CH122)	76.120	-	-	-	-
5690 (CH138)	72.920	-	-	-	-

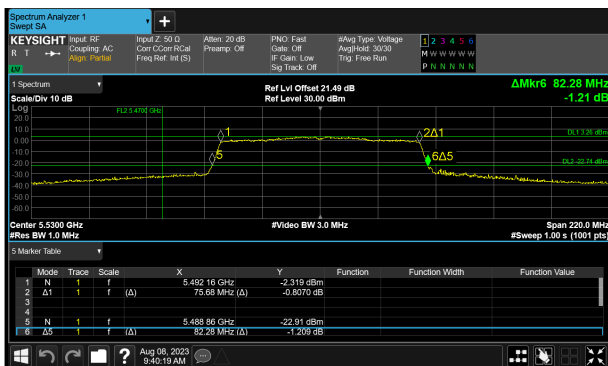

SP1-C0 (1) 5530 MHz (CH106) 26 dB and 99% Bandwidth

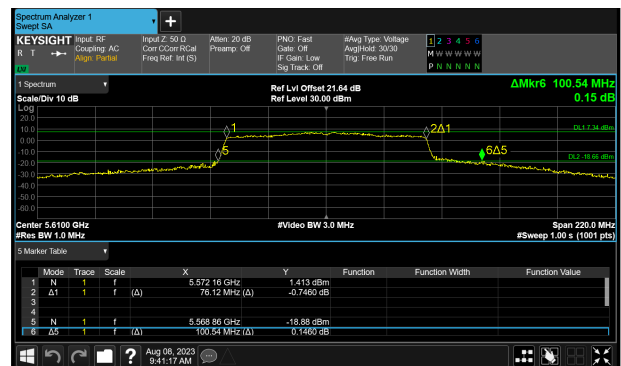

SP1-C0 (1) 5610 MHz (CH122) 26 dB and 99% Bandwidth

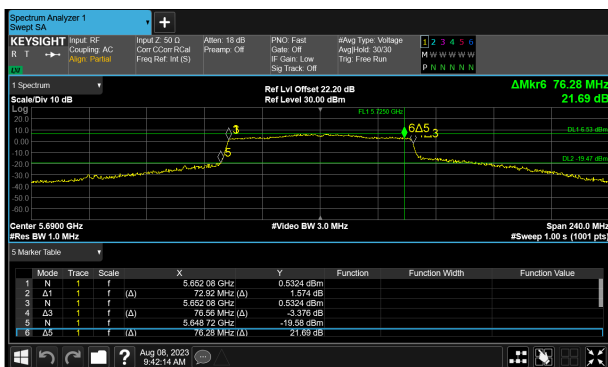

SP1-C0 (1) 5690 MHz (CH138) 26 dB and 99% Bandwidth

Transmitter 6 dB & 99% Emission Bandwidth (5.725-5.85 GHz band) (continued)**4.1.4 5.725-5.85 GHz band**

Frequency Range:	5.725-5.850 GHz	Band:	U-NII-3
Limit Clause:	15.407(e) RSS-247 6.2.4.1	Test Method:	C63.10 6.9.3 C63.10 12.4.1

Antenna Configuration:	SISO	Mode:	802.11a
Test Port:	1 (SP1-C0)	Modulation/Rate:	6 Mbps (BPSK)

Test Frequency (MHz)	6 dB Bandwidth (MHz)				Limit (kHz)
	1	2	3	4	
5720 (CH144)	3.220	-	-	-	≥500.0
5745 (CH149)	16.440	-	-	-	≥500.0
5785 (CH157)	16.440	-	-	-	≥500.0
5825 (CH165)	16.440	-	-	-	≥500.0

Test Frequency (MHz)	99% Bandwidth (MHz)				Limit (kHz)
	1	2	3	4	
5720 (CH144)	3.580	-	-	-	-
5745 (CH149)	17.040	-	-	-	-
5785 (CH157)	16.920	-	-	-	-
5825 (CH165)	16.860	-	-	-	-

Transmitter 6 dB & 99% Emission Bandwidth (5.725-5.85 GHz band) (continued)

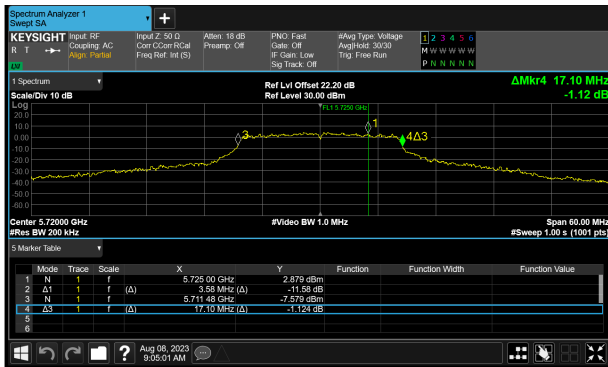

SP1-C0 (1) 5720 MHz (CH144) 99% Bandwidth

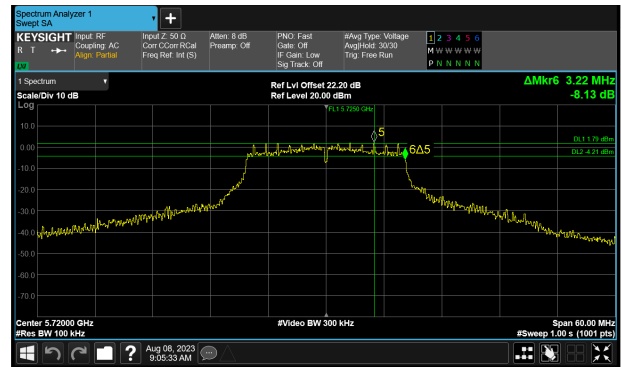

SP1-C0 (1) 5720 MHz (CH144) 6 dB Bandwidth

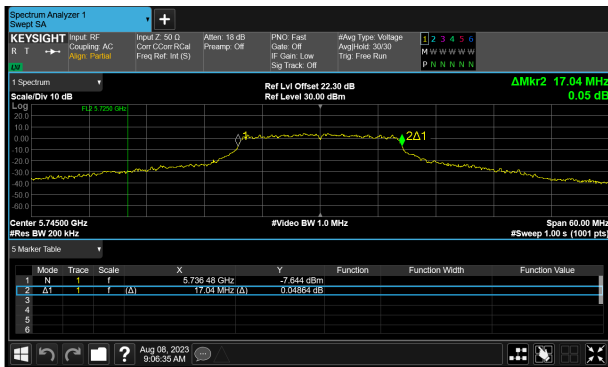

SP1-C0 (1) 5745 MHz (CH149) 99% Bandwidth

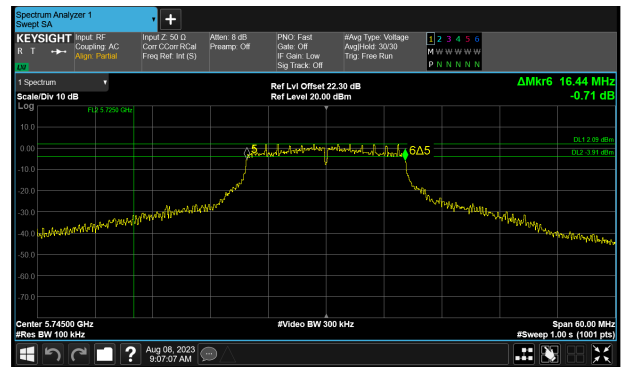

SP1-C0 (1) 5745 MHz (CH149) 6 dB Bandwidth

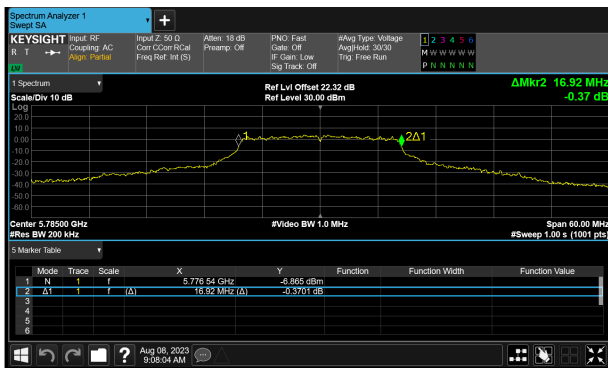

SP1-C0 (1) 5785 MHz (CH157) 99% Bandwidth

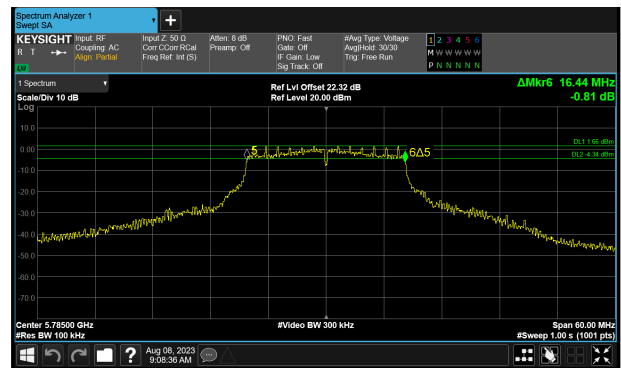

SP1-C0 (1) 5785 MHz (CH157) 6 dB Bandwidth

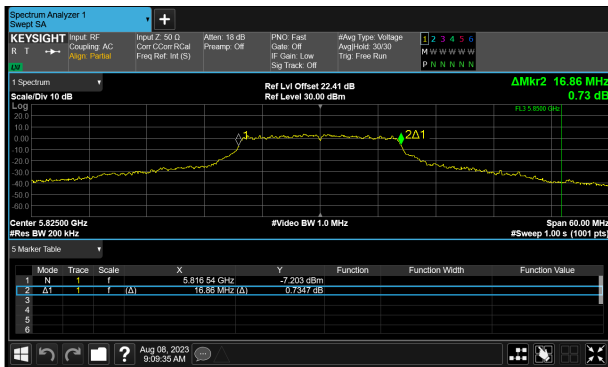

SP1-C0 (1) 5825 MHz (CH165) 99% Bandwidth

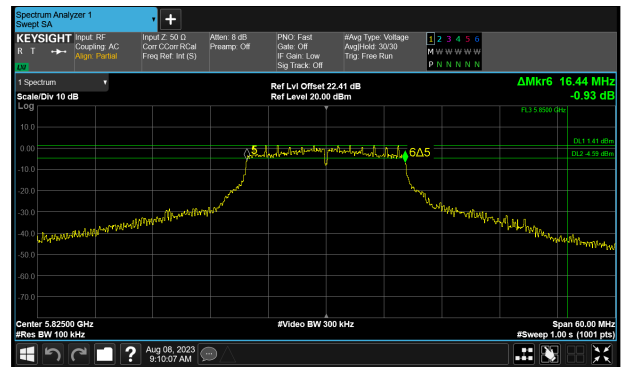

SP1-C0 (1) 5825 MHz (CH165) 6 dB Bandwidth

Transmitter 6 dB & 99% Emission Bandwidth (5.725-5.85 GHz band) (continued)

Frequency Range:	5.725-5.850 GHz	Band:	U-NII-3
Limit Clause:	15.407(e) RSS-247 6.2.4.1	Test Method:	C63.10 6.9.3 C63.10 12.4.1

Antenna Configuration:	SISO	Mode:	802.11n HT20
Test Port:	1 (SP1-C0)	Modulation/Rate:	MCS0 (BPSK)

Test Frequency (MHz)	6 dB Bandwidth (MHz)				Limit (kHz)
	1	2	3	4	
5720 (CH144)	3.820	-	-	-	≥500.0
5745 (CH149)	17.640	-	-	-	≥500.0
5785 (CH157)	17.640	-	-	-	≥500.0
5825 (CH165)	17.640	-	-	-	≥500.0

Test Frequency (MHz)	99% Bandwidth (MHz)				Limit (kHz)
	1	2	3	4	
5720 (CH144)	4.120	-	-	-	-
5745 (CH149)	18.180	-	-	-	-
5785 (CH157)	18.180	-	-	-	-
5825 (CH165)	18.120	-	-	-	-