



TEST REPORT

Test Report No. : UL-RPT-RP11287331JD07A

Manufacturer : Raspberry Pi (Trading) Ltd
Model No. : v1.1
FCC ID : 2ABCB-RPI0W
Technology : WLAN
Test Standard(s) : FCC Parts 15.209(a) & 15.247

1. This test report shall not be reproduced in full or partial, without the written approval of UL VS LTD.
2. The results in this report apply only to the sample(s) tested.
3. The sample tested is in compliance with the above standard(s).
4. The test results in this report are traceable to the national or international standards.
5. Version 2.0 supersedes all previous versions.

Date of Issue: 21 December 2016

Checked by:

Ian Watch
Senior Engineer, Radio Laboratory

Company Signatory:

Sarah Williams
Senior Engineer, Radio Laboratory
UL VS LTD



This laboratory is accredited by UKAS.
The tests reported herein have been
performed in accordance with its terms
of accreditation.

UL VS LTD

Pavilion A, Ashwood Park, Ashwood Way, Basingstoke, Hampshire, RG23 8BG, UK
Telephone: +44 (0)1256 312000
Facsimile: +44 (0)1256 312001

This page has been left intentionally blank.

Table of Contents

1. Customer Information.....	4
2. Summary of Testing.....	5
2.1. General Information	5
2.2. Summary of Test Results	5
2.3. Methods and Procedures	5
2.4. Deviations from the Test Specification	5
3. Equipment Under Test (EUT)	6
3.1. Identification of Equipment Under Test (EUT)	6
3.2. Description of EUT	6
3.3. Modifications Incorporated in the EUT	6
3.4. Additional Information Related to Testing	7
3.5. Support Equipment	8
4. Operation and Monitoring of the EUT during Testing	9
4.1. Operating Modes	9
4.2. Configuration and Peripherals	9
5. Measurements, Examinations and Derived Results.....	10
5.1. General Comments	10
5.2. Test Results	11
5.2.1. Transmitter Minimum 6 dB Bandwidth	11
5.2.2. Transmitter Duty Cycle	16
5.2.3. Transmitter Power Spectral Density	22
5.2.4. Transmitter Maximum (Average) Output Power	27
5.2.5. Transmitter Radiated Emissions	34
5.2.6. Transmitter Band Edge Radiated Emissions	42
6. Measurement Uncertainty	55
7. Report Revision History	56

1. Customer Information







Company Name:	Raspberry Pi (Trading) Ltd
Address:	30 Station Road Cambridge CB1 2JH United Kingdom

2. Summary of Testing

2.1. General Information

Specification Reference:	47CFR15.247
Specification Title:	Code of Federal Regulations Volume 47 (Telecommunications): Part 15 Subpart C (Intentional Radiators) - Section 15.247
Specification Reference:	47CFR15.209
Specification Title:	Code of Federal Regulations Volume 47 (Telecommunications): Part 15 Subpart C (Intentional Radiators) – Section 15.209
Site Registration:	209735
Location of Testing:	UL VS LTD, Unit 3 Horizon, Wade Road, Kingsland Business Park, Basingstoke, Hampshire, RG24 8AH, United Kingdom
Test Dates:	22 September 2016 to 28 September 2016

2.2. Summary of Test Results

FCC Reference (47CFR)	Measurement	Result
Part 15.247(a)(2)	Transmitter Minimum 6 dB Bandwidth	
Part 15.35(c)	Transmitter Duty Cycle	Note 1
Part 15.247(e)	Transmitter Power Spectral Density	
Part 15.247(b)(3)	Transmitter Maximum (Average) Output Power	
Part 15.247(d) / 15.209(a)	Transmitter Radiated Emissions	
Part 15.247(d) / 15.209(a)	Transmitter Band Edge Radiated Emissions	
Key to Results		
 = Complied  = Did not comply		

Note(s):

1. The measurement was performed to assist in the calculation of the level of maximum conducted output power, power spectral density and emissions. The EUT cannot transmit continuously and sweep triggering/signal gating cannot be implemented.

2.3. Methods and Procedures

Reference:	ANSI C63.10-2013
Title:	American National Standard of Procedures for Compliance Testing of Unlicensed Wireless Devices
Reference:	KDB 558074 D01 DTS Meas Guidance v03r05 April 8, 2016
Title:	Guidance for Performing Compliance Measurements on Digital Transmission Systems (DTS) Operating Under §15.247

2.4. Deviations from the Test Specification

For the measurements contained within this test report, there were no deviations from, additions to, or exclusions from the test specification identified above.

3. Equipment Under Test (EUT)

3.1. Identification of Equipment Under Test (EUT)

Brand Name:	Raspberry Pi Zero W
Model Name or Number:	v1.1
Test Sample Serial Number:	UL Sample ID # 3 (<i>Radiated sample</i>)
Hardware Version:	1.1
Software Version:	4.4
FCC ID:	2ABCB-RPI0W

Brand Name:	Raspberry Pi Zero W
Model Name or Number:	v1.1
Test Sample Serial Number:	3F09ED53 (<i>Conducted sample with RF port</i>)
Hardware Version:	1.1
Software Version:	4.4
FCC ID:	2ABCB-RPI0W

3.2. Description of EUT

The Equipment Under Test was a single board computer. It contains a Bluetooth and 2.4 GHz WLAN module. It is powered from an AC/DC power supply.

3.3. Modifications Incorporated in the EUT

No modifications were applied to the EUT during testing.

3.4. Additional Information Related to Testing

Technology Tested:	WLAN (IEEE 802.11b,g,n) / Digital Transmission System		
Type of Unit:	Transceiver		
Modulation Type:	DBPSK, DQPSK, BPSK, QPSK, 16QAM & 64QAM		
Data Rates:	802.11b	1, 2, 5.5 & 11 Mbps	
	802.11g	6, 9, 12, 18, 24, 36, 48 & 54 Mbps	
	802.11n HT20	MCS0 to MCS7	
Power Supply Requirement(s):	Nominal	5 VDC from AC/DC power supply	
Antenna Gain:	2.0 dBi		
Channel Spacing:	20 MHz		
Transmit Frequency Range:	2412 MHz to 2462 MHz		
Transmit Channels Tested:	Channel	RF Channel	Channel Frequency (MHz)
	Bottom	1	2412
	Middle	6	2437
	Top	11	2462

3.5. Support Equipment

The following support equipment was used to exercise the EUT during testing:

Description:	Power Supply. 120 VAC Input / 5 VDC output
Brand Name:	Strontronics Ltd
Model Name or Number:	DSA-12CA-05
Serial Number:	Not marked or stated

Description:	LCD Monitor
Brand Name:	Asus
Model Name or Number:	PA238
Serial Number:	Not marked or stated

Description:	USB Keyboard
Brand Name:	Microsoft
Model Name or Number:	Not marked or stated
Serial Number:	Not marked or stated

Description:	USB Hub
Brand Name:	Not marked or stated
Model Name or Number:	Not marked or stated
Serial Number:	Not marked or stated

Description:	HDMI B to HDMI C cable
Brand Name:	Not marked or stated
Model Name or Number:	Not marked or stated
Serial Number:	Not marked or stated

Description:	Cyclone Micro Media Player Adaptor
Brand Name:	Sumvision
Model Name or Number:	Cyclone Micro
Serial Number:	SUM091104017

4. Operation and Monitoring of the EUT during Testing

4.1. Operating Modes

The EUT was tested in the following operating mode(s):

- Continuously transmitting with a modulated carrier at maximum power on the bottom, middle and top channels as required using the supported data rates/modulation types.

4.2. Configuration and Peripherals

The EUT was tested in the following configuration(s):

- Controlled using a terminal application, either remotely or on the EUT, to select and configure the chipset manufacturer's test commands which are built into the driver. They enabled the test engineer to start a continuous transmission mode and to select the test channels, data rates and modulation schemes as required.
- The radiated spurious emissions test was performed with the EUT in the worst-case orientation/position. The Cyclone Micro Media Player Adaptor was used as a termination for the HDMI cable. All other ports were terminated with suitable terminations.
- The LCD monitor was connected to the EUT using a 2 metre long HDMI cable.
- The keyboard and mouse were connected to the USB hub and the hub connected to the USB port on the EUT.
- The EUT was powered via an AC/DC switch mode power supply for all tests.
- For minimum 6 dB bandwidth, duty cycle, power spectral density and maximum (average) power tests, the EUT was tested in all supported 802.11 modes on top middle and bottom channels. Only the worst-case modes are presented in this report, these are based on the highest measured level of all three channels. Results for other modes are archived on the UL VS LTD IT server and available for inspection upon request.
- For radiated spurious emissions tests, the EUT was tested in the mode which was found to give the highest level emissions:
 - 802.11b– DQPSK / 2 Mbps
- For band edge radiated emissions tests, the EUT was tested in the modes that exhibited the highest power and widest bandwidths on the channels closest to the band edge:
 - 802.11b – DQPSK / 2 Mbps
 - 802.11g – QPSK / 12 Mbps
 - 802.11g – 64QAM / 54 Mbps
 - 802.11n / HT20 – 16QAM / MCS3
- The conducted sample with serial number 3F09ED53 was used for minimum 6 dB bandwidth, duty cycle, maximum output power and power spectral density tests.
- The EUT radiated sample UL Sample ID # 3 was used for all other tests.

5. Measurements, Examinations and Derived Results

5.1. General Comments

Measurement uncertainties are evaluated in accordance with current best practice. Our reported expanded uncertainties are based on standard uncertainties, which are multiplied by an appropriate coverage factor to provide a statistical confidence level of approximately 95%. Please refer to *Section 6. Measurement Uncertainty* for details.

In accordance with UKAS requirements all the measurement equipment is on a calibration schedule. All equipment was within the calibration period on the date of testing.

5.2. Test Results

5.2.1. Transmitter Minimum 6 dB Bandwidth

Test Summary:

Test Engineer:	Philip Harrison	Test Date:	28 September 2016
Test Sample Serial Number:	3F09ED53		

FCC Reference:	Part 15.247(a)(2)
Test Method Used:	FCC KDB 558074 Section 8.1

Environmental Conditions:

Temperature (°C):	24
Relative Humidity (%):	46

Note(s):

- All configurations supported by the EUT were investigated on one channel in accordance with KDB 558074 Section 8.1 Option 1 measurement procedure. The signal analyser resolution bandwidth was set to 100 kHz and video bandwidth 300 kHz. A peak detector was used. The DTS bandwidth was measured at 6 dB down from the peak of the signal. The span was set to 30 MHz, sweep time was set to auto and the trace mode was Max Hold. The data rates that produced the narrowest bandwidth and therefore deemed worst-case were:
 - 802.11b – DBPSK / 1 Mbps
 - 802.11g – BPSK / 6 Mbps
 - 802.11n HT20 – BPSK / MCS0
- Final measurements were performed using the above configurations on the bottom, middle and top channels in accordance with KDB 558074 Section 8.1 Option 1 measurement procedure.
- Plots for all data rates are archived on the UL VS LTD IT server and available for inspection upon request.
- The signal analyser was connected to the RF port on the EUT using suitable attenuation and RF cable.

Test setup:

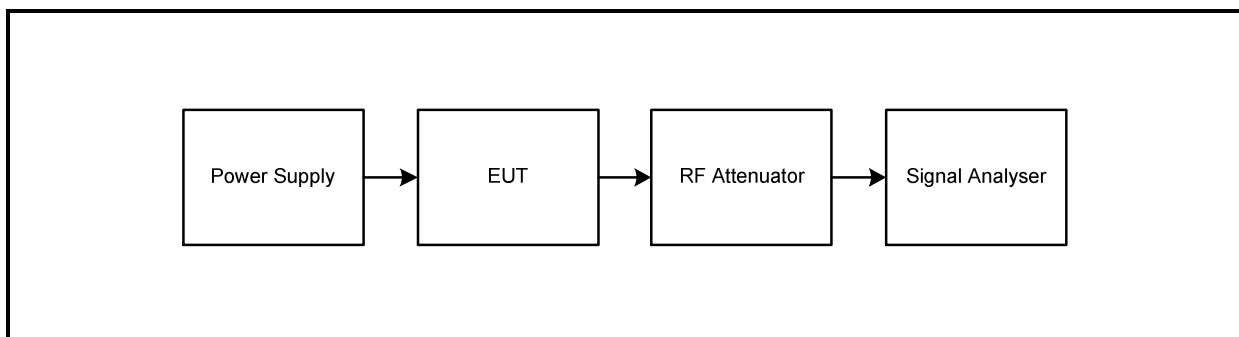

Transmitter Minimum 6 dB Bandwidth (continued)

Results: 802.11b / DBPSK / 1 Mbps

Channel	6 dB Bandwidth (kHz)	Limit (kHz)	Margin (kHz)	Result
Bottom	8162	≥500	7662	Complied
Middle	9117	≥500	Complied	
Top	9117	≥500	8617	Complied

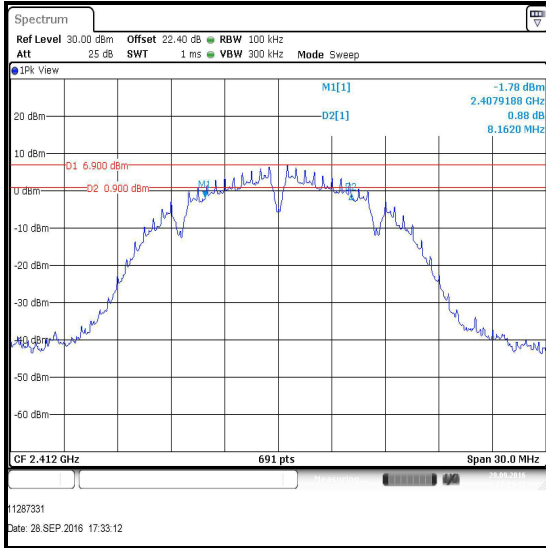

Bottom Channel

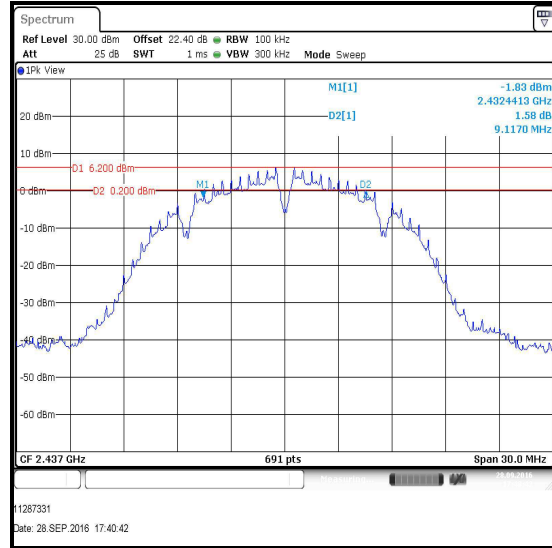

Middle Channel

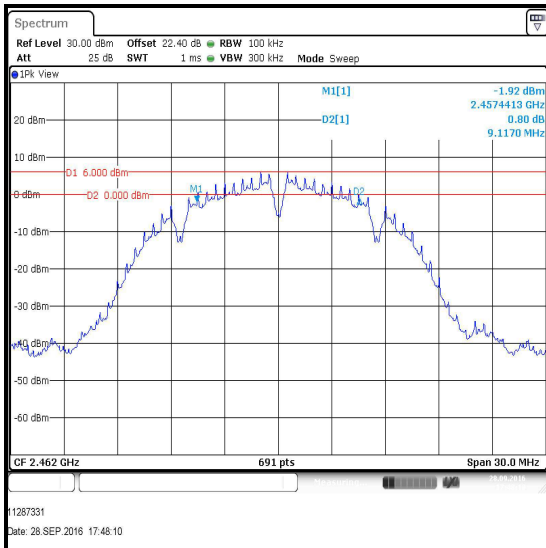

Top Channel

Transmitter Minimum 6 dB Bandwidth (continued)

Results: 802.11g / BPSK / 6 Mbps

Channel	6dB Bandwidth (kHz)	Limit (kHz)	Margin (kHz)	Result
Bottom	15152	≥500	14652	Complied
Middle	15195	≥500	14695	Complied
Top	15195	≥500	14695	Complied

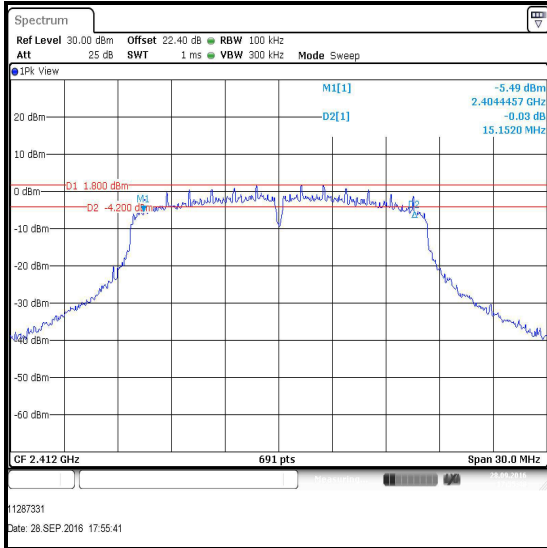

Bottom Channel

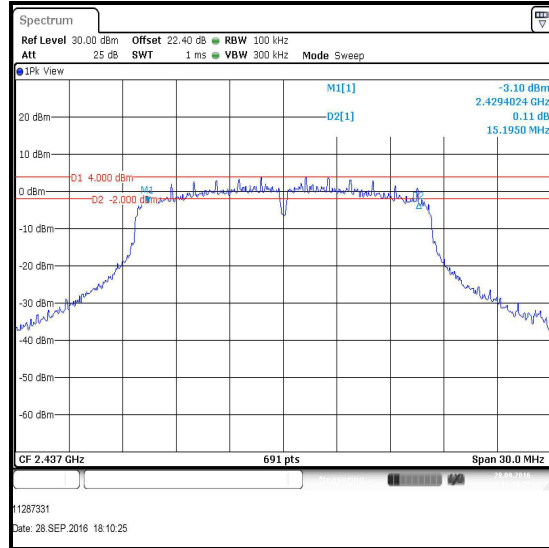

Middle Channel

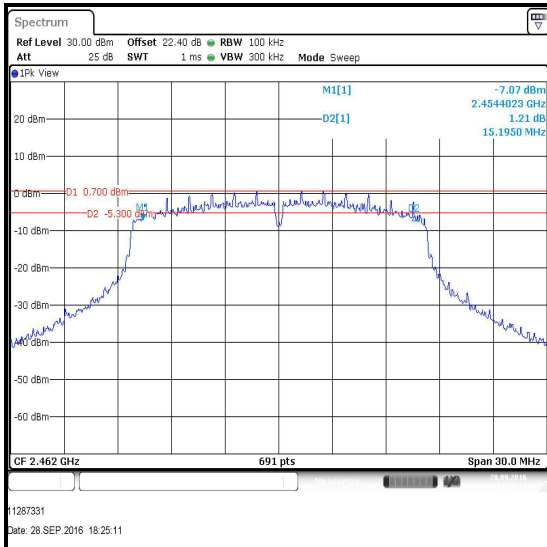

Top Channel

Transmitter Minimum 6 dB Bandwidth (continued)

Results: 802.11n / BPSK / MCS0

Channel	6dB Bandwidth (kHz)	Limit (kHz)	Margin (kHz)	Result
Bottom	15195	≥500	14695	Complied
Middle	15195	≥500	14695	Complied
Top	15195	≥500	14695	Complied

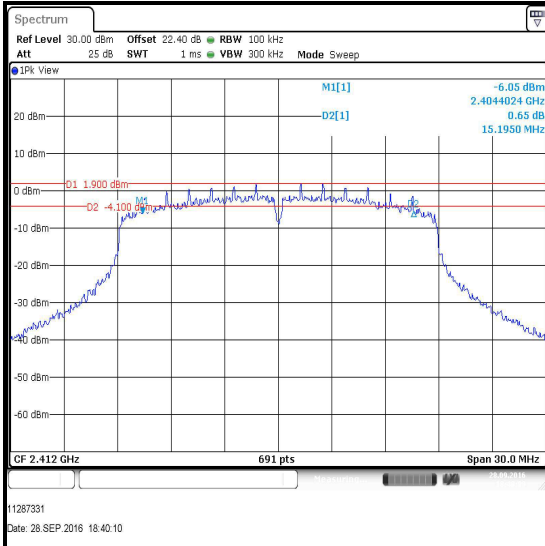

Bottom Channel

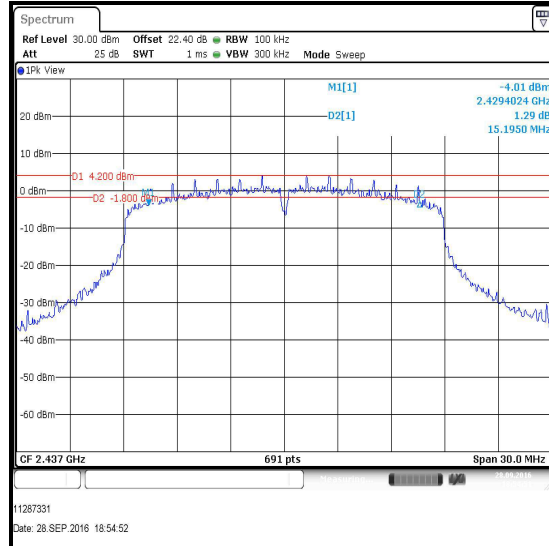

Middle Channel

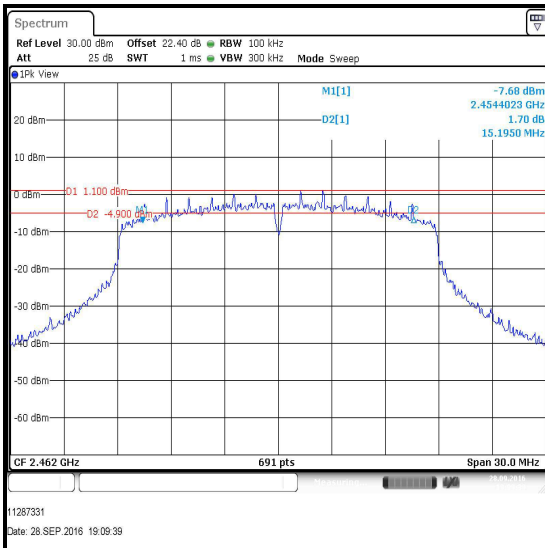

Top Channel

Transmitter Minimum 6 dB Bandwidth (continued)**Test Equipment Used:**

Asset No.	Instrument	Manufacturer	Type No.	Serial No.	Date Calibration Due	Cal. Interval (Months)
M2001	Thermohygrometer	Testo	608-H1	45041824	02 Apr 2017	12
M1883	Signal Analyser	Rohde & Schwarz	FSV-30	103084	09 May 2017	12
G0614	Signal Generator	Rohde & Schwarz	SMB100A	177687	01 May 2017	36
A2143	20 dB Attenuator	AtlanTecRF	AN18-20	081120-23	Calibrated before use	-

5.2.2. Transmitter Duty Cycle

Test Summary:

Test Engineer:	Philip Harrison	Test Date:	28 September 2016
Test Sample Serial Number:	3F09ED53		

FCC Reference:	Part 15.35(c)
Test Method Used:	FCC KDB 558074 Section 6.0

Environmental Conditions:

Temperature (°C):	24
Relative Humidity (%):	46

Note(s):

1. In order to assist with the determination of the average level of fundamental and spurious emissions field strength, measurements were made of duty cycle to determine the transmission duration and the silent period time of the transmitter. The transmitter duty cycle was measured using a signal analyser in the time domain and the duty cycle correction figure calculated by using the following calculation:

$$10 \log (1 / (\text{On Time} / [\text{Period or } 100 \text{ ms whichever is the lesser}]))$$

For all 802.11 devices the period is always less than 100 ms and therefore the calculation simplifies to:

$$10 \log (\text{Period} / \text{On Time})$$

Test setup:

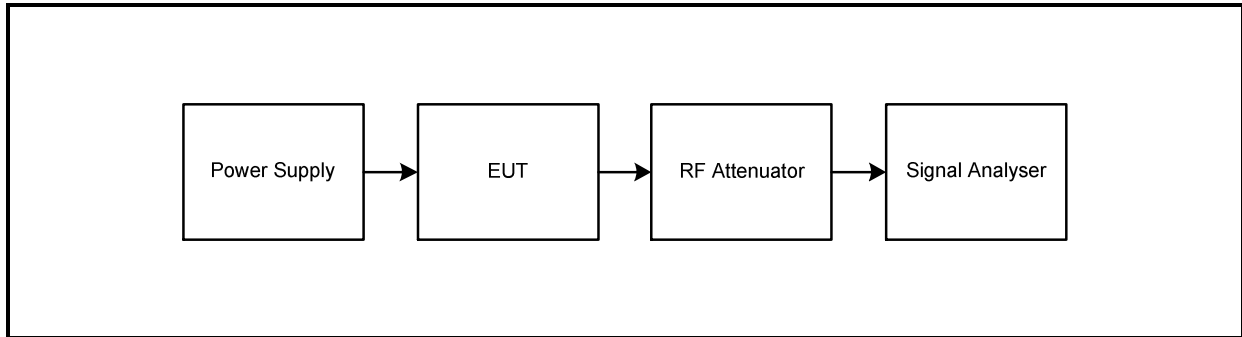

Transmitter Duty Cycle (continued)

Results: 802.11b / DQPSK / 2 Mbps

Channel	Pulse Width (ms)	Pulse Period (ms)	Duty Cycle Correction factor (dB)
Middle	4.1881	4.2411	0.0



Middle Channel

Transmitter Duty Cycle (continued)

Results: 802.11b / DQPSK / 11 Mbps

Channel	Pulse Width (ms)	Pulse Period (ms)	Duty Cycle Correction factor (dB)
Middle	0.8418	0.8835	0.2

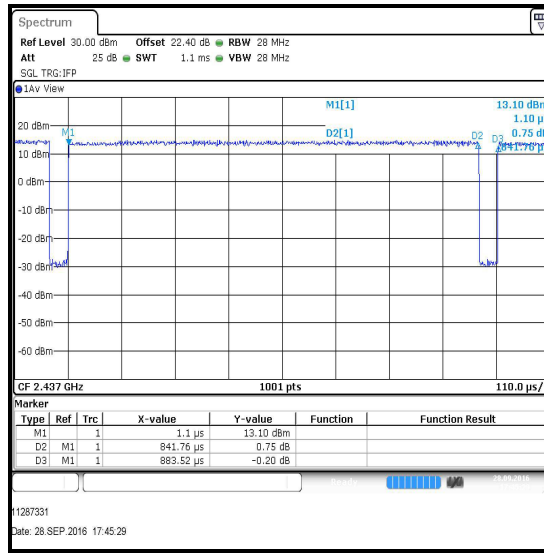

Middle Channel

Transmitter Duty Cycle (continued)

Results: 802.11g / QPSK / 12 Mbps

Channel	Pulse Width (ms)	Pulse Period (ms)	Duty Cycle Correction factor (dB)
Middle	0.7054	0.7483	0.3

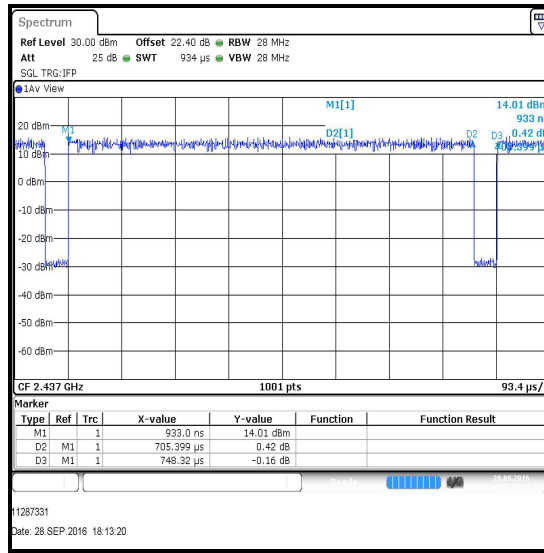

Middle Channel

Transmitter Duty Cycle (continued)

Results: 802.11g / 64QAM / 54 Mbps

Channel	Pulse Width (ms)	Pulse Period (ms)	Duty Cycle Correction factor (dB)
Middle	0.1755	0.2158	0.9

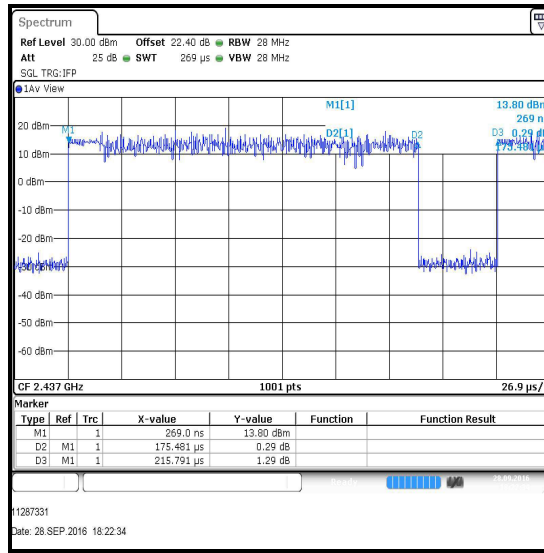

Middle Channel

Transmitter Duty Cycle (continued)

Results: 802.11n / 16QAM / MCS3

Channel	Pulse Width (ms)	Pulse Period (ms)	Duty Cycle Correction factor (dB)
Middle	0.3550	0.3972	0.5

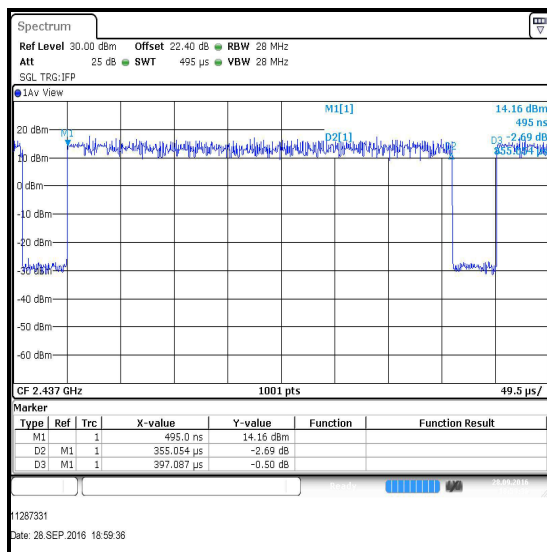

Middle Channel

Test Equipment Used:

Asset No.	Instrument	Manufacturer	Type No.	Serial No.	Date Calibration Due	Cal. Interval (Months)
M2001	Thermohygrometer	Testo	608-H1	45041824	02 Apr 2017	12
M1883	Signal Analyser	Rohde & Schwarz	FSV-30	103084	09 May 2017	12
G0614	Signal Generator	Rohde & Schwarz	SMB100A	177687	01 May 2017	36
A2143	20 dB Attenuator	AtlanTecRF	AN18-20	081120-23	Calibrated before use	-

5.2.3. Transmitter Power Spectral Density

Test Summary:

Test Engineer:	Philip Harrison	Test Date:	28 September 2016
Test Sample Serial Number:	3F09ED53		

FCC Reference:	Part 15.247(e)
Test Method Used:	FCC KDB 558074 Sections 10.3 &10.5

Environmental Conditions:

Temperature (°C):	24
Relative Humidity (%):	46

Note(s):

- All configurations supported by the EUT were investigated. The configurations that produced the highest power spectral density and therefore deemed worst-case were:
 - 802.11b - DQPSK / 2 Mbps
 - 802.11g - 64QAM / 54 Mbps
 - 802.11n HT20 - 16QAM / MCS3
- Final measurements were performed using the above configurations on the bottom, middle and top channels. Results for all other modes are archived on the UL VS LTD IT server and are available for inspection if required.
- For modes where the EUT was transmitting at $\geq 98\%$ duty cycle and testing was performed in accordance with KDB 558074 Section 10.3 Method AVGPST-1. The signal analyser resolution bandwidth was set to 100 kHz and video bandwidth 300 kHz. An RMS detector was used and sweep time set manually to perform trace averaging over 300 traces. The span was set to >1.5 times the 99% occupied bandwidth. The highest peak of the measured signal was recorded.
- For modes where the EUT was transmitting at $<98\%$ duty cycle and testing was performed in accordance with KDB 558074 Section 10.5 Method AVGPST-2. The signal analyser resolution bandwidth was set to 100 kHz and video bandwidth 300 kHz. An RMS detector was used and sweep time set manually to perform trace averaging over 300 traces. The span was set to >1.5 times the 99% occupied bandwidth. The highest peak of the measured signal was recorded. The duty cycle calculated in Section 5.2.2 of this test report was added to the measured average power spectral density in order to compute the average power spectral density during the actual transmission time.
- The signal analyser was connected to the RF port on the EUT using suitable attenuation and RF cable. An RF level offset was entered on the signal analyser to compensate for the loss of the attenuator and RF cable.

Test setup:

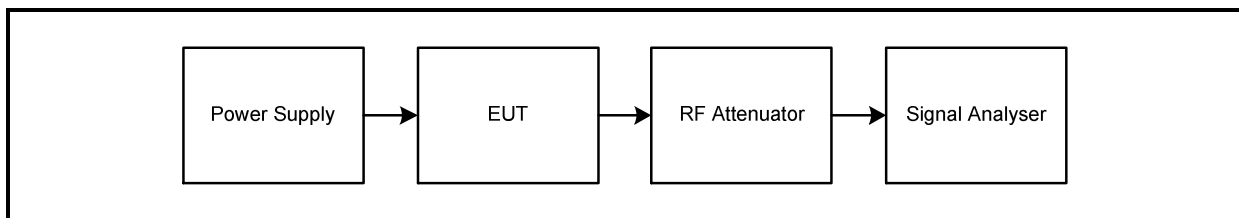

Transmitter Power Spectral Density (continued)

Results: 802.11b / DQPSK / 2 Mbps

Channel	Output Power (dBm/100 kHz)	Duty Cycle Correction (dB)	Output Power (dBm/100 kHz)	Limit (dBm/3kHz)	Margin (dB)	Result
Bottom	-2.2	0.0	-2.2	8.0	10.2	Complied
Middle	-2.1	0.0	-2.1	8.0	10.1	Complied
Top	-2.5	0.0	-2.5	8.0	10.5	Complied

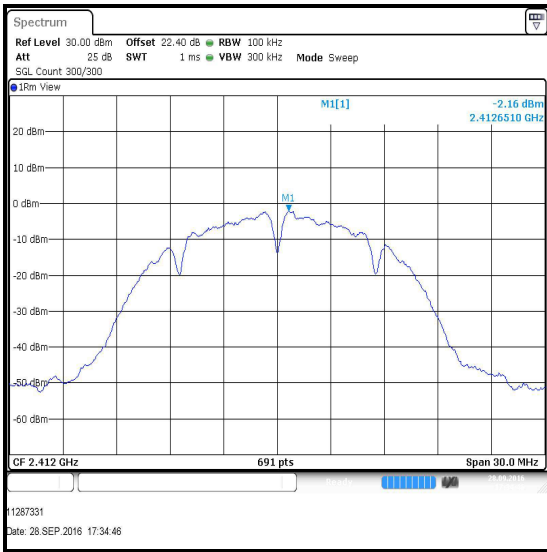

Bottom Channel

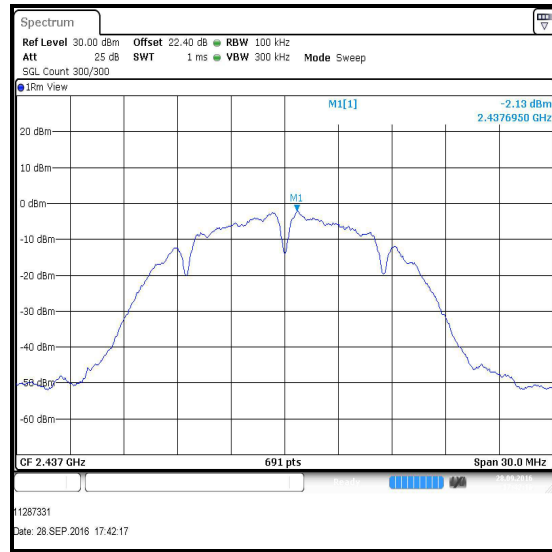

Middle Channel

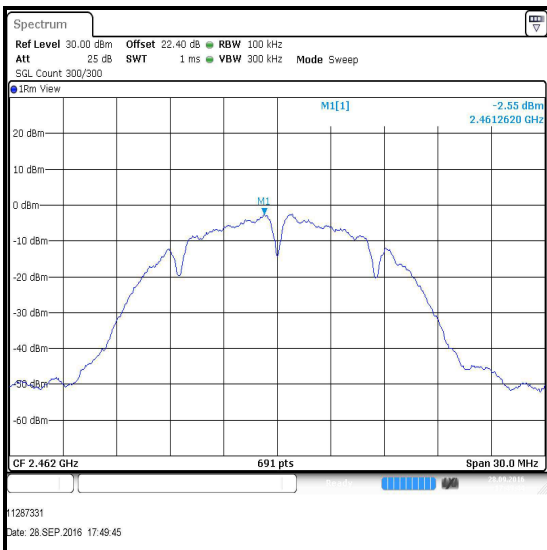

Top Channel

Transmitter Power Spectral Density (continued)

Results: 802.11g / 64QAM / 54 Mbps

Channel	Output Power (dBm/100 kHz)	Duty Cycle Correction (dB)	Corrected Output Power (dBm/100 kHz)	Limit (dBm/3kHz)	Margin (dB)	Result
Bottom	-7.1	0.9	-6.2	8.0	14.2	Complied
Middle	-4.6	0.9	-3.7	8.0	11.7	Complied
Top	-8.2	0.9	-7.3	8.0	15.3	Complied

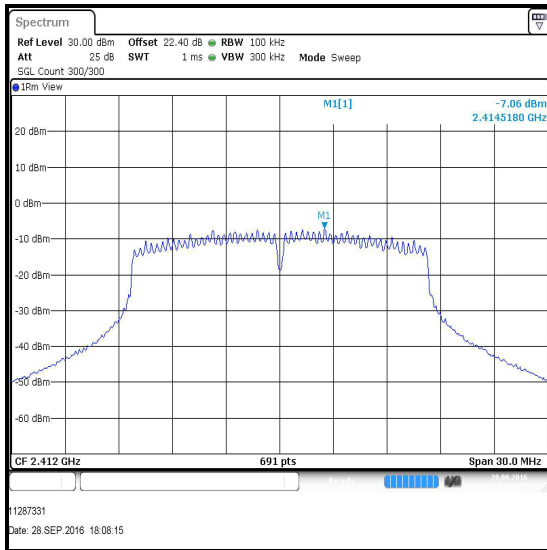

Bottom Channel

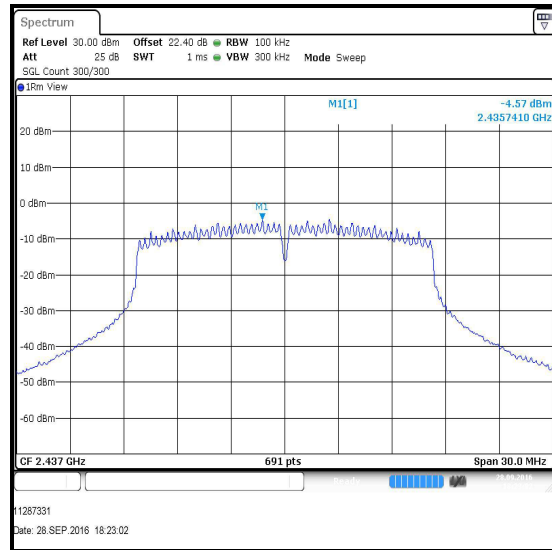

Middle Channel

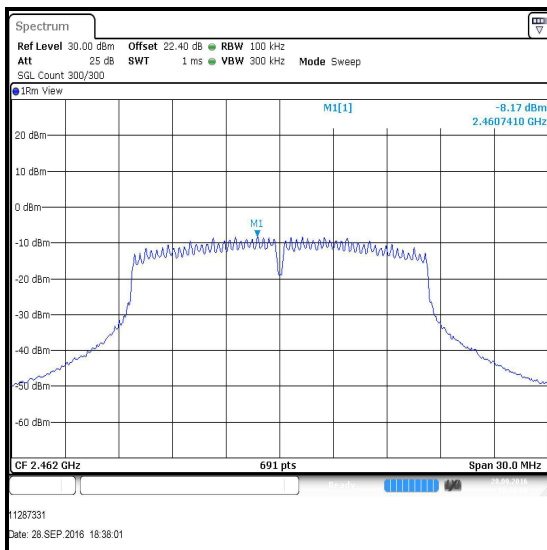

Top Channel

Transmitter Power Spectral Density (continued)

Results: 802.11n / 16QAM / MCS3

Channel	Output Power (dBm/100 kHz)	Duty Cycle Correction (dB)	Corrected Output Power (dBm/100 kHz)	Limit (dBm/3kHz)	Margin (dB)	Result
Bottom	-7.0	0.5	-6.5	8.0	14.5	Complied
Middle	-4.5	0.5	-4.0	8.0	12.0	Complied
Top	-8.0	0.5	-7.5	8.0	15.5	Complied

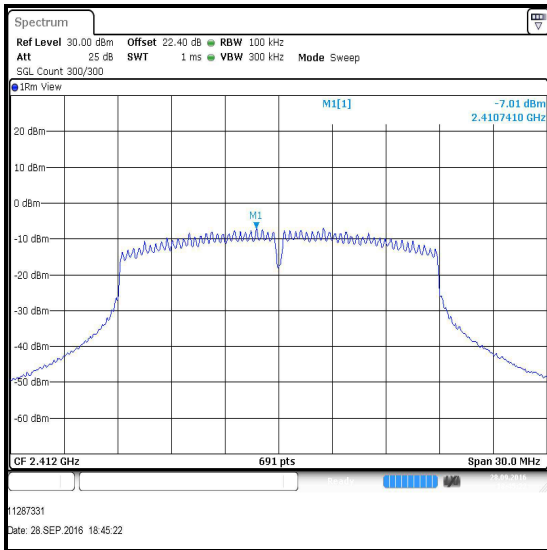

Bottom Channel

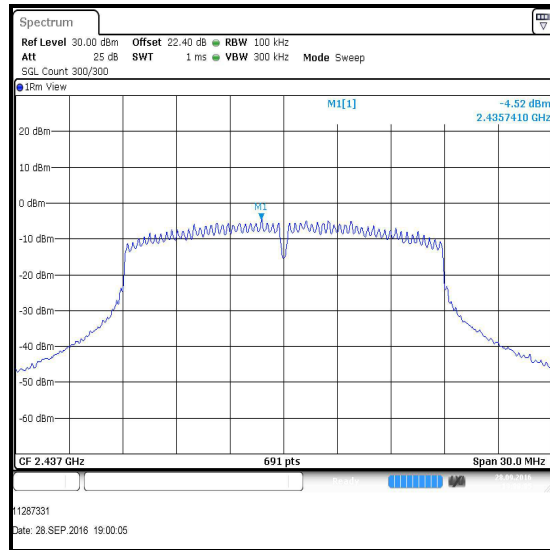

Middle Channel

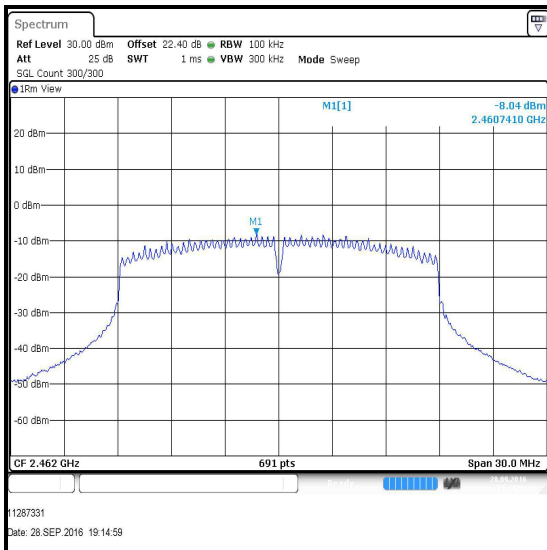

Top Channel

Transmitter Power Spectral Density (continued)**Test Equipment Used:**

Asset No.	Instrument	Manufacturer	Type No.	Serial No.	Date Calibration Due	Cal. Interval (Months)
M2001	Thermohygrometer	Testo	608-H1	45041824	02 Apr 2017	12
M1883	Signal Analyser	Rohde & Schwarz	FSV-30	103084	09 May 2017	12
G0614	Signal Generator	Rohde & Schwarz	SMB100A	177687	01 May 2017	36
A2143	20 dB Attenuator	AtlanTecRF	AN18-20	081120-23	Calibrated before use	-

5.2.4. Transmitter Maximum (Average) Output Power**Test Summary:**

Test Engineer:	Philip Harrison	Test Date:	28 September 2016
Test Sample Serial Number:	3F09ED53		

FCC Reference:	Part 15.247(b)(3)
Test Method Used:	FCC KDB 558074 Section 9.2.2.4

Environmental Conditions:

Temperature (°C):	24
Relative Humidity (%):	46

Note(s):

- All configurations supported by the EUT were investigated. The configurations that produced the highest power and therefore deemed worst-case were:
 - 802.11b - DQPSK / 11 Mbps
 - 802.11g - QPSK / 12 Mbps
 - 802.11n HT20 - 16QAM / MCS3
- Measurements were performed using the above configurations on the bottom, middle and top channels. Results for all other modes are archived on the UL VS LTD IT server and are available for inspection if required.
- For the worst-case configurations shown above, the EUT was transmitting at <98% duty cycle and testing was performed in accordance with KDB 558074 Section 9.2.2.4 Method AVGSA-2. The signal analyser's integration function was used to integrate across the 99% occupied bandwidth. The signal analyser resolution bandwidth was set to 300 kHz and video bandwidth 1 MHz for 802.11b measurements. The signal analyser resolution bandwidth was set to 500 kHz and video bandwidth 2 MHz for 802.11g / 802.11n measurements. An RMS detector was used and sweep time set to auto. The span was set to >1.5 times the 99% occupied bandwidth. The duty cycle calculated in Section 5.2.2 of this test report was added to the measured average power in order to compute the average power density during the actual transmission time.
- The signal analyser was connected to the RF port on the EUT using suitable attenuation and RF cable. An RF level offset was entered on the signal analyser to compensate for the loss of the attenuator and RF cable.

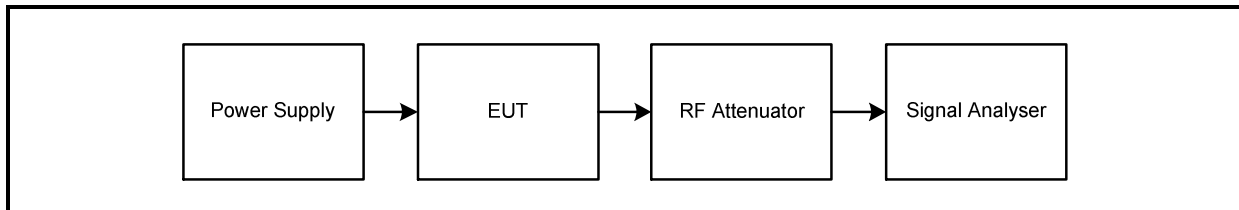
Test setup:

Transmitter Maximum (Average) Output Power (continued)**Results: 802.11b / DQPSK / 11 Mbps****Conducted Limit Comparison**

Channel	Conducted Power (dBm)	Duty Cycle Correction (dB)	Corrected Conducted Power (dBm)	Conducted Power Limit (dBm)	Margin (dB)	Result
Bottom	14.5	0.2	14.7	30.0	15.3	Complied
Middle	14.1	0.2	14.3	30.0	15.7	Complied
Top	14.1	0.2	14.3	30.0	15.7	Complied

De Facto EIRP Limit Comparison

Channel	Conducted Power (dBm)	Declared Antenna Gain (dBi)	EIRP (dBm)	De Facto EIRP Limit (dBm)	Margin (dB)	Result
Bottom	14.7	2.0	16.7	36.0	19.3	Complied
Middle	14.3	2.0	16.3	36.0	19.7	Complied
Top	14.3	2.0	16.3	36.0	19.7	Complied

Transmitter Maximum (Average) Output Power (continued)

Results: 802.11b / DQPSK / 11 Mbps

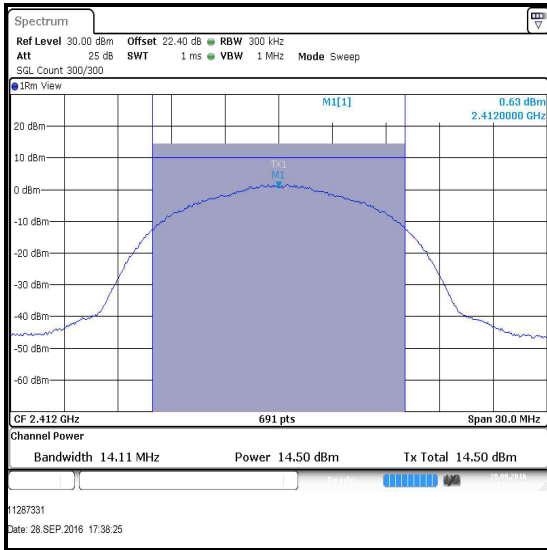

Bottom Channel

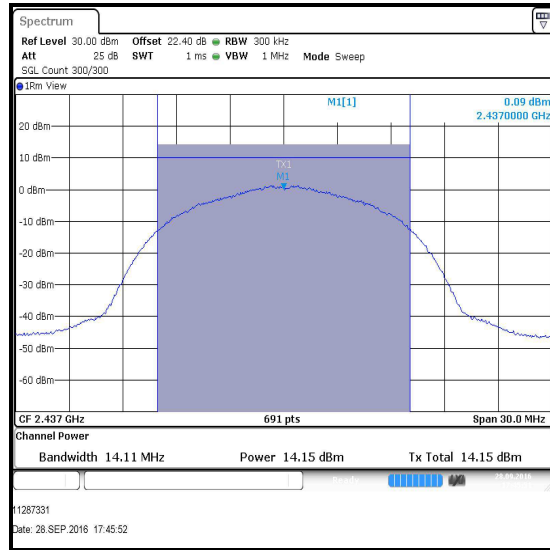

Middle Channel

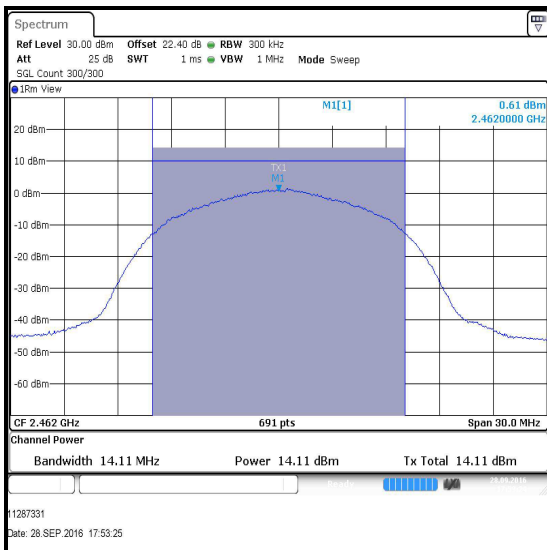

Top Channel

Transmitter Maximum (Average) Output Power (continued)**Results: 802.11g / QPSK / 12 Mbps****Conducted Peak Limit Comparison**

Channel	Conducted Power (dBm)	Duty Cycle Correction (dB)	Corrected Conducted Power (dBm)	Conducted Power Limit (dBm)	Margin (dB)	Result
Bottom	12.2	0.3	12.5	30.0	17.5	Complied
Middle	14.6	0.3	14.9	30.0	15.1	Complied
Top	11.3	0.3	11.6	30.0	18.4	Complied

De Facto EIRP Limit Comparison

Channel	Conducted Power (dBm)	Declared Antenna Gain (dBi)	EIRP (dBm)	De Facto EIRP Limit (dBm)	Margin (dB)	Result
Bottom	12.5	2.0	14.5	36.0	21.5	Complied
Middle	14.9	2.0	16.9	36.0	19.1	Complied
Top	11.6	2.0	13.6	36.0	22.4	Complied

Transmitter Maximum (Average) Output Power (continued)

Results: 802.11g / QPSK / 12 Mbps

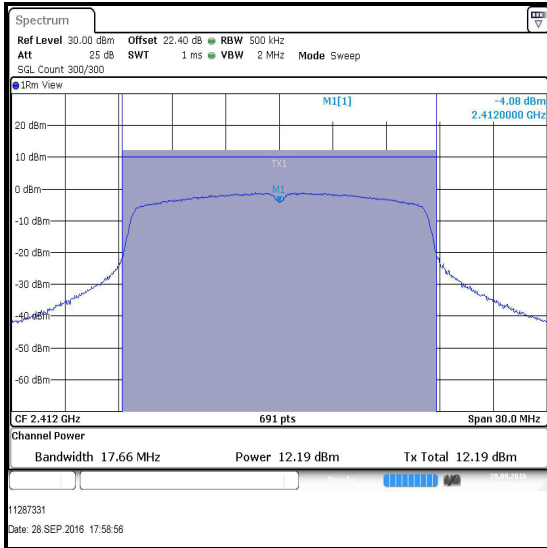

Bottom Channel

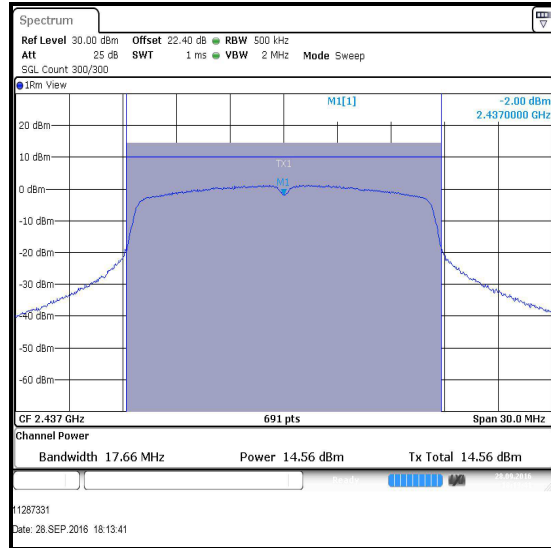

Middle Channel

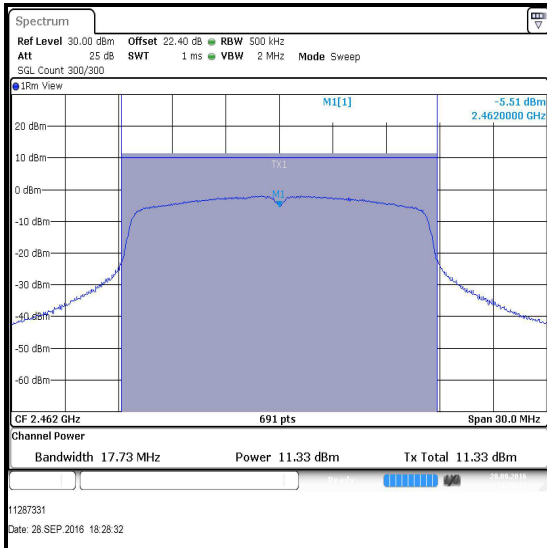

Top Channel

Transmitter Maximum (Average) Output Power (continued)**Results: 802.11n / 16QAM / MCS3****Conducted Peak Limit Comparison**

Channel	Conducted Power (dBm)	Duty Cycle Correction (dB)	Corrected Conducted Power (dBm)	Conducted Power Limit (dBm)	Margin (dB)	Result
Bottom	11.9	0.5	12.4	30.0	17.6	Complied
Middle	14.3	0.5	14.8	30.0	15.2	Complied
Top	10.8	0.5	11.3	30.0	18.7	Complied

De Facto EIRP Limit Comparison

Channel	Conducted Power (dBm)	Declared Antenna Gain (dBi)	EIRP (dBm)	De Facto EIRP Limit (dBm)	Margin (dB)	Result
Bottom	12.4	2.0	14.4	36.0	21.6	Complied
Middle	14.8	2.0	16.8	36.0	19.2	Complied
Top	11.3	2.0	13.3	36.0	22.7	Complied

Transmitter Maximum (Average) Output Power (continued)

Results: 802.11n / 16QAM / MCS3

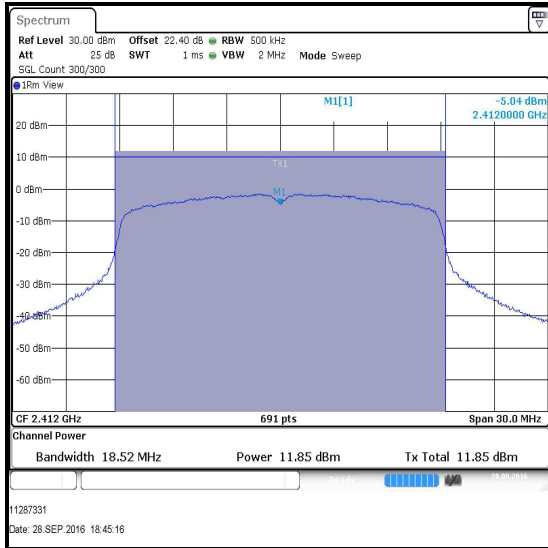

Bottom Channel

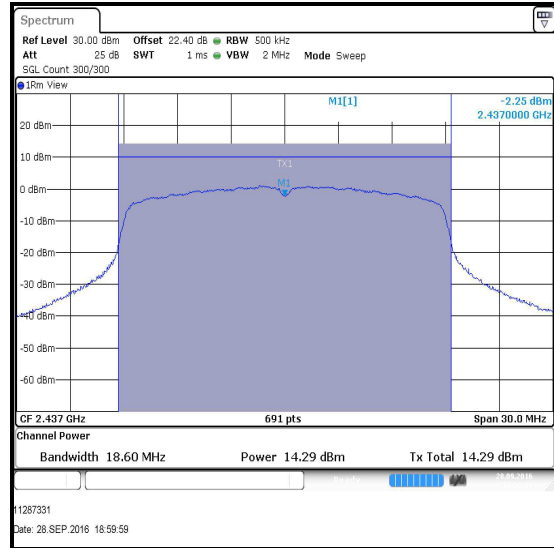

Middle Channel

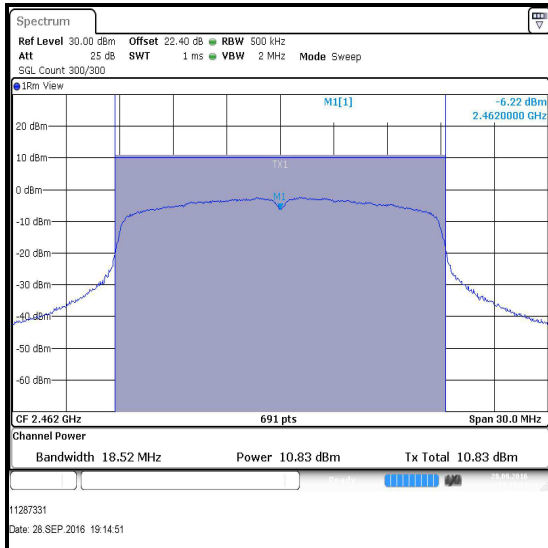

Top Channel

Test Equipment Used:

Asset No.	Instrument	Manufacturer	Type No.	Serial No.	Date Calibration Due	Cal. Interval (Months)
M2001	Thermohygrometer	Testo	608-H1	45041824	02 Apr 2017	12
M1883	Signal Analyser	Rohde & Schwarz	FSV-30	103084	09 May 2017	12
G0614	Signal Generator	Rohde & Schwarz	SMB100A	177687	01 May 2017	36
A2143	20 dB Attenuator	AtlanTecRF	AN18-20	081120-23	Calibrated before use	-

5.2.5. Transmitter Radiated Emissions**Test Summary:**

Test Engineer:	David Doyle	Test Date:	28 September 2016
Test Sample Serial Number:	UL Sample ID # 3		

FCC Reference:	Parts 15.247(d) & 15.209(a)
Test Method Used:	ANSI C63.10 Sections 6.3 and 6.5
Frequency Range	30 MHz to 1000 MHz

Environmental Conditions:

Temperature (°C):	23
Relative Humidity (%):	45

Note(s):

1. The final measured value, for the given emission, in the table below incorporates the calibrated antenna factor and cable loss.
2. The preliminary scans showed similar emission levels below 1 GHz, for each channel of operation. Therefore final radiated emissions measurements were performed with the EUT set to the middle channel only.
3. All other emissions shown on the pre-scan plots were investigated and found to be ambient, or >20 dB below the applicable limit or below the measurement system noise floor and therefore not recorded.
4. Measurements below 1 GHz were performed in a semi-anechoic chamber (Asset Number K0001) at a distance of 3 metres. The EUT was placed at a height of 80 cm above the reference ground plane in the centre of the chamber turntable. Maximum emission levels were determined by height searching the measurement antenna over the range 1 metre to 4 metres.
5. Pre-scans were performed and markers placed on the highest measured levels. The test receiver resolution bandwidth was set to 100 kHz and video bandwidth 300 kHz. A peak detector was used, sweep time was set to auto and trace mode was Max Hold.
6. Final measurements were performed on the marker frequencies and the results entered into the table below. The test receiver resolution bandwidth was set to 120 kHz, using a CISPR quasi-peak detector and span wide enough to see the whole emission.

Transmitter Radiated Emissions (continued)

Test setup for radiated measurements:

Semi-anechoic chamber

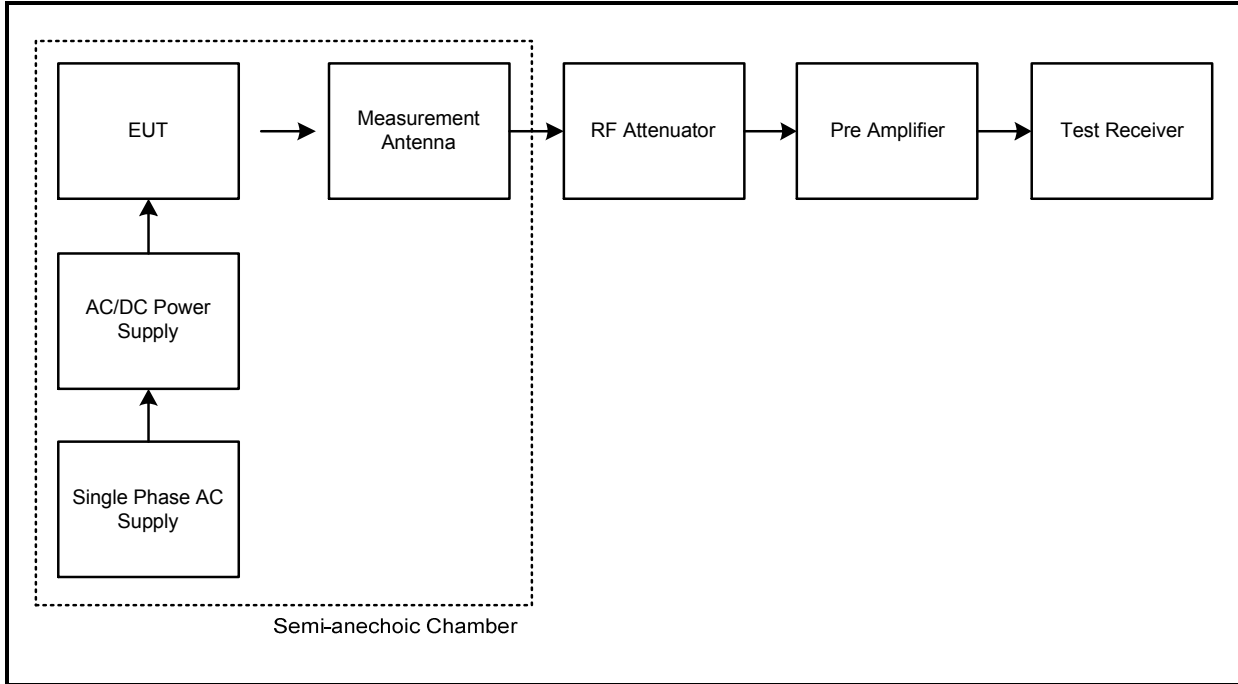

Anechoic chamber

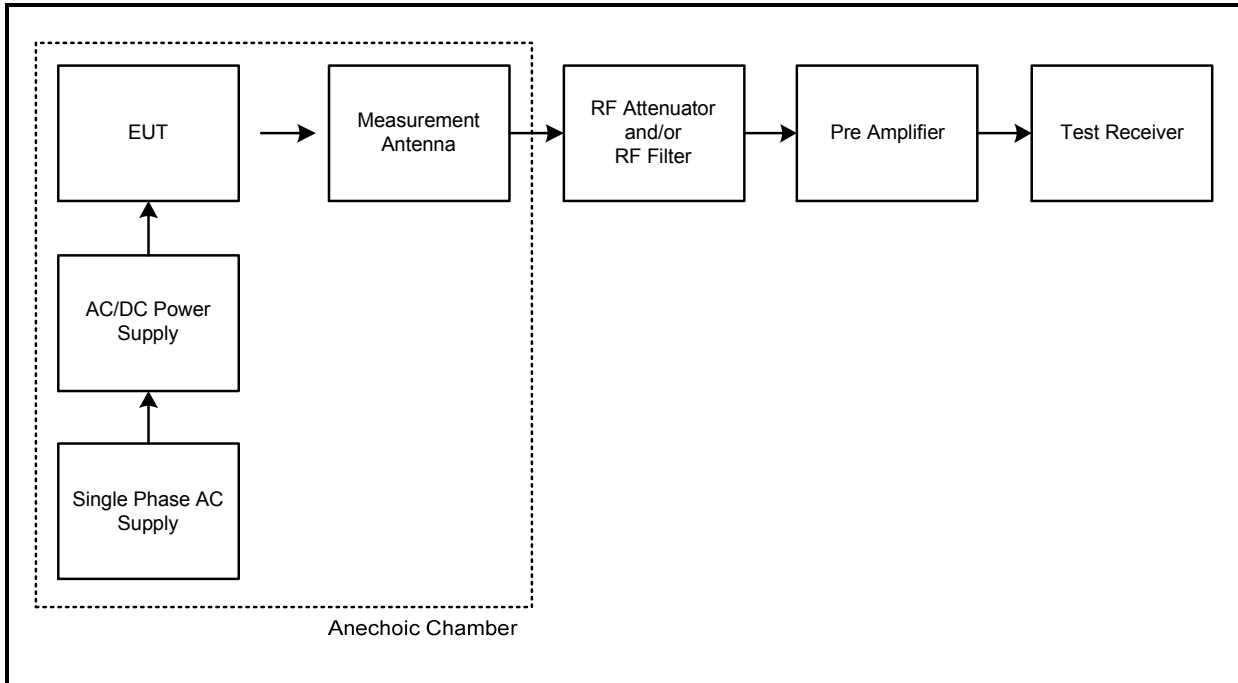

Transmitter Radiated Emissions (continued)**Results: Middle Channel / 802.11b / DQPSK / 2 Mbps**

Frequency (MHz)	Antenna Polarity	Level (dB μ V/m)	Limit (dB μ V/m)	Margin (dB)	Result
125.015	Vertical	23.6	43.5	19.9	Complied

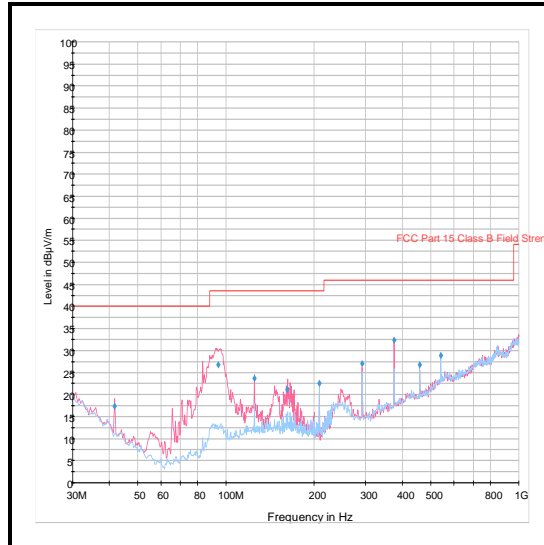
**Test Equipment Used:**

Asset No.	Instrument	Manufacturer	Type No.	Serial No.	Date Calibration Due	Cal. Interval (Months)
M1625	Thermohygrometer	JM Handelspunkt	30.5015.06	None stated	11 Jan 2017	12
K0001	5m RSE Chamber	Rainford EMC	N/A	N/A	12 Jan 2017	12
A1834	Attenuator	Hewlett Packard	8491B	10444	30 Mar 2017	12
G0543	Amplifier	Sonoma	310N	230801	09 Dec 2016	6
M1273	Test Receiver	Rohde & Schwarz	ESIB26	100275	11 Apr 2017	12
A2959	Antenna	Schwarzbeck	VULB 9163	9163-967	08 Sep 2017	12

Transmitter Radiated Emissions (continued)**Test Summary:**

Test Engineer:	David Doyle	Test Date:	27 September 2016
Test Sample Serial Number:	UL Sample ID # 3		

FCC Reference:	Parts 15.247(d) & 15.209(a)
Test Method Used:	ANSI C63.10 Sections 6.3 and 6.6
Frequency Range	1 GHz to 25 GHz

Environmental Conditions:

Temperature (°C):	25
Relative Humidity (%):	47

Note(s):

1. The final measured value, for the given emission, in the table below incorporates the calibrated antenna factor and cable loss.
2. All emissions shown on the precscan plots were investigated and found to be >20 dB below the applicable limit, therefore the highest peak and average noise floor readings of the measuring receiver were recorded as shown in the tables below.
3. The emission shown approximately at 2437 MHz on the 1 GHz to 3 GHz plot is the EUT fundamental.
4. Pre-scans above 1 GHz were performed in a fully anechoic chamber (Asset Number K0002) at a distance of 3 metres. The EUT was placed at a height of 1.5 metres above the test chamber floor in the centre of the chamber turntable. All measurement antennas were placed at a fixed height of 1.5 metres above the test chamber floor, in line with the EUT.
5. Pre-scans were performed and a marker placed on the highest measured level of the appropriate plot. The test receiver resolution bandwidth was set to 1 MHz and video bandwidth 3 MHz. The sweep time was set to auto.

Transmitter Radiated Emissions (continued)**Results: Peak**

Frequency (MHz)	Antenna Polarity	Peak Level (dB μ V/m)	Peak Limit (dB μ V/m)	Margin (dB)	Result
2836.000	Vertical	55.5	74.0	18.5	Complied

Results: Average

Frequency (MHz)	Antenna Polarity	Average Level (dB μ V/m)	Average Limit (dB μ V/m)	Margin (dB)	Result
2985.500	Vertical	43.6	54.0	10.4	Complied

Transmitter Radiated Emissions (continued)

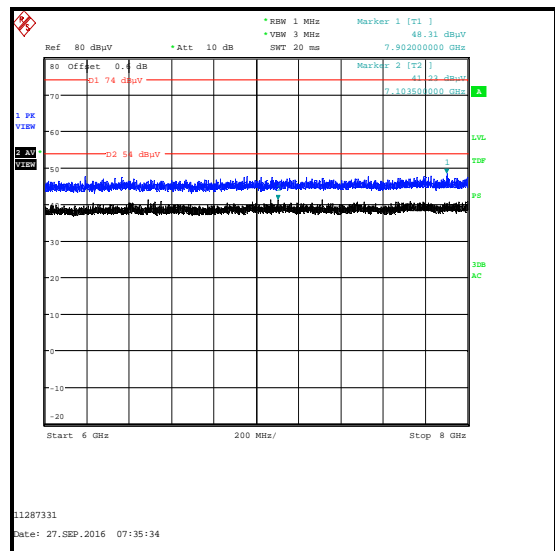
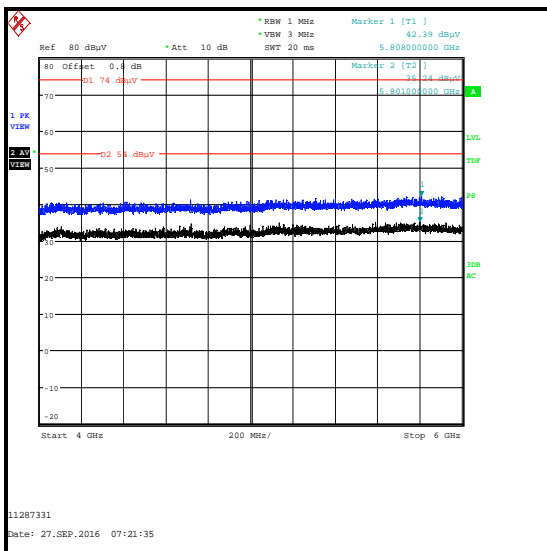
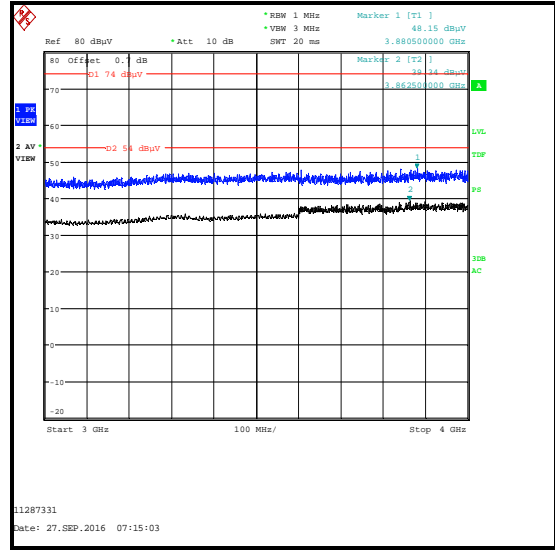
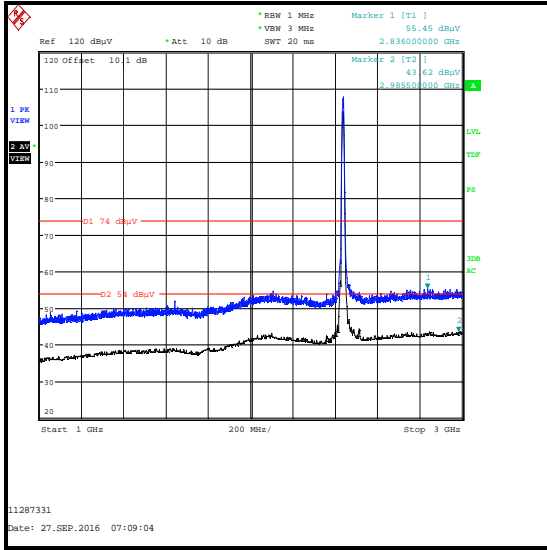

Transmitter Radiated Emissions (continued)

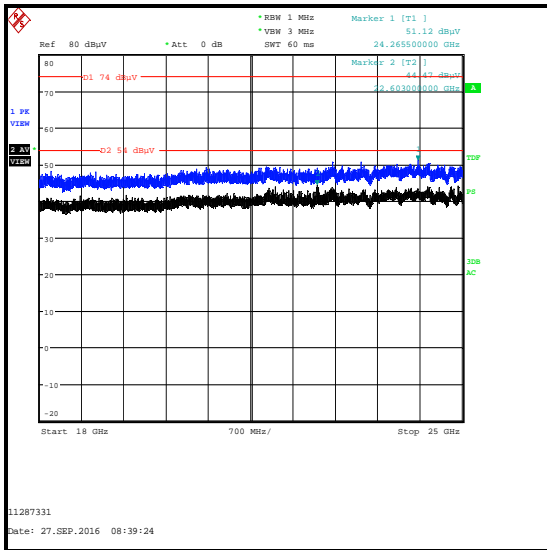
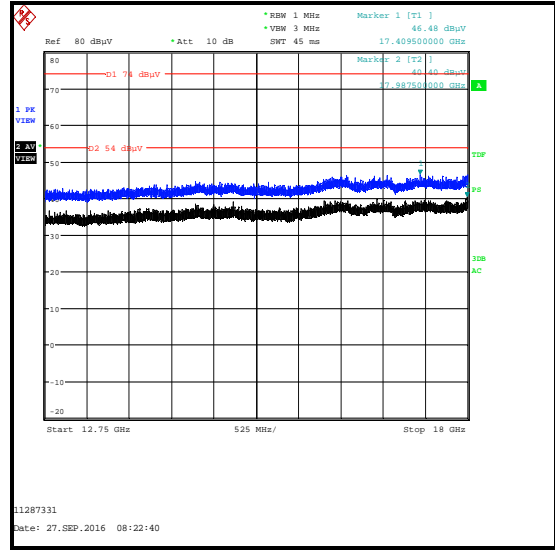
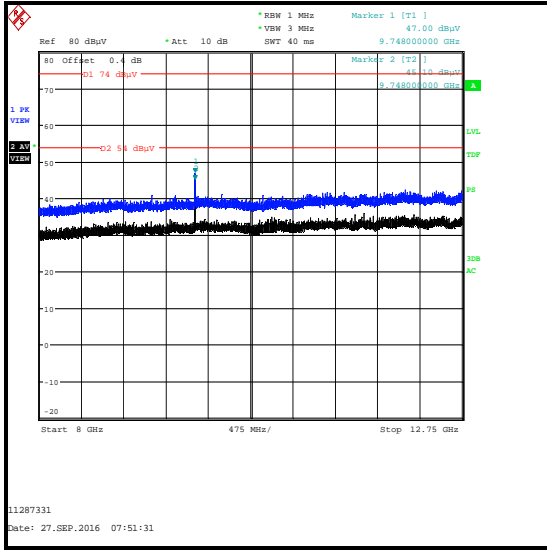

Transmitter Radiated Emissions (continued)**Test Equipment Used:**

Asset No	Instrument	Manufacturer	Type No.	Serial No.	Date Calibration Due	Cal. Interval (Months)
M1656	Thermohygrometer	JM Handelspunkt	30.5015.13	Not stated	02 Apr 2017	12
K0002	3m RSE Chamber	Rainford EMC	N/A	N/A	21 Dec 2016	12
M1886	Test Receiver	Rohde & Schwarz	ESU26	100554	21 May 2017	12
A1534	Pre Amplifier	Hewlett Packard	8449B	3008A00405	19 Dec 2016	12
A1818	Antenna	EMCO	3115	00075692	17 Dec 2016	12
A253	Antenna	Flann Microwave	12240-20	128	17 Dec 2016	12
A254	Antenna	Flann Microwave	14240-20	139	17 Dec 2016	12
A255	Antenna	Flann Microwave	16240-20	519	17 Dec 2016	12
A256	Antenna	Flann Microwave	18240-20	400	17 Dec 2016	12
A436	Antenna	Flann Microwave	20240-20	330	19 Dec 2016	12
A1396	Attenuator	Huber & Suhner	6810.17.B	757987	26 Apr 2017	12
A1975	High Pass Filter	AtlanTecRF	AFH-03000	090424010	26 Apr 2017	12

5.2.6. Transmitter Band Edge Radiated Emissions**Test Summary:**

Test Engineer:	David Doyle	Test Dates:	22 September 2016, 23 September 2016 & 28 September 2016
Test Sample Serial Number:	UL Sample ID # 3		

FCC Reference:	Parts 15.247(d) & 15.209(a)
Test Method Used:	ANSI C63.10 Section 6.10 & FCC KDB 558074 Sections 11, 12 & 13

Environmental Conditions:

Temperature (°C):	23 to 27
Relative Humidity (%):	45 to 51

Note(s):

- Tests were performed in the following modes as they produced the highest power, highest power spectral density, and widest occupied bandwidth:
 - 802.11b – DQPSK / 2 Mbps
 - 802.11g – QPSK / 12 Mbps
 - 802.11g – 64QAM / 54 Mbps
 - 802.11n HT20 - 16QAM / MCS3
- The final measured value, for the given emission, in the table below incorporates the calibrated antenna factor and cable loss.
- As the lower band edge falls within a non-restricted band, only peak measurements are required. In accordance with FCC KDB 558074 Section 11.1, the test method in Section 11.3 was followed: the test receiver resolution bandwidth was set to 100 kHz and video bandwidth 300 kHz. A peak detector was used, sweep time was set to auto and trace mode was Max Hold. The test receiver was left to sweep for a sufficient length of time in order to maximise the carrier level and out-of-band emissions. A marker and corresponding reference level line were placed on the peak of the carrier. As the maximum conducted (average) output power was measured using an RMS detector in accordance with FCC KDB 558074 Section 9.2.2.4 an out-of-band limit line was placed 30 dB (FCC KDB 558074 Section 11.1(b)) below the peak level. A marker was placed on the band edge spot frequencies and a second marker placed on the highest emission level in the adjacent non-restricted band of operation (where a higher level emission was present). Marker frequencies and levels were recorded.
NOTE: The lower band edge plot for 802.11b / DQPSK / 2 Mbps incorrectly shows the limit line at -20 dBc. The result table shows the correct limit.
- As the upper band edge falls within a restricted band, both peak and average measurements were recorded by placing a marker at the edge of the band. For peak measurements the test receiver resolution bandwidth was set to 1 MHz and the video bandwidth 3 MHz. A peak and average detectors were used, sweep time was set to auto and trace mode was Max Hold. The test receiver was left to sweep for a sufficient length of time in order to maximise the carrier level and out-of-band emissions. A marker was placed on the band edge spot frequencies and a second marker placed on the highest emission level in the adjacent restricted band of operation (where a higher level emission was present). Marker frequencies and levels were recorded.

Transmitter Band Edge Radiated Emissions (continued)**Note(s):**

5. *The integration method was used in accordance with FCC KDB 558074 Section 13.3.2, in order to meet the average limit when transmitting in 802.11g and 802.11n modes. As the EUT had a duty cycle <98%, in some configurations, the duty cycle correction factor has been applied to the band edge and 2310 to 2390 MHz restricted band average results. The corrected average levels are shown below and in the result tables:

Integration method result + duty cycle = Corrected band edge level

802.11g / QPSK / 12 Mbps at 2483.5 MHz: 52.1 + 0.3 dB = 52.4
802.11g / 64QAM / 54 Mbps at 2483.5 MHz: 51.3 + 0.9 dB = 52.2
802.11n HT20 / 16QAM / MCS3 at 2483.5 MHz: 51.1 + 0.5 dB = 51.6

Integration method result + duty cycle = Corrected restricted band level

802.11g / QPSK / 12 Mbps at 2483.5 MHz: 50.8 + 0.3 dB = 51.1
802.11g / 64QAM / 54 Mbps at 2483.5 MHz: 48.8 + 0.9 dB = 49.7
802.11n HT20 / 16QAM / MCS3 at 2483.5 MHz: 53.0 + 0.5 dB = 53.5

Transmitter Band Edge Radiated Emissions (continued)**Results: 802.11b / DQPSK / 2 Mbps / Lower Band Edge**

Frequency (MHz)	Level (dB μ V/m)	-30 dBc Limit (dB μ V/m)	Margin (dB)	Result
2399.519	59.8	71.7	31.9	Complied
2400.000	57.1	71.7	34.6	Complied

Results: 802.11b / DQPSK / 2 Mbps / Upper Band Edge / Peak

Frequency (MHz)	Level (dB μ V/m)	Limit (dB μ V/m)	Margin (dB)	Result
2483.500	58.1	74.0	15.9	Complied
2491.272	60.1	74.0	13.9	Complied

Results: 802.11b / DQPSK / 2 Mbps / Upper Band Edge / Average

Frequency (MHz)	Level (dB μ V/m)	Limit (dB μ V/m)	Margin (dB)	Result
2483.500	50.8	54.0	3.2	Complied
2491.192	53.6	54.0	0.4	Complied

Results: 2310 to 2390 MHz Restricted Band

Frequency (MHz)	Peak Level (dB μ V/m)	Peak Limit (dB μ V/m)	Margin (dB)	Result
2386.538	57.0	74.0	17.0	Complied

Frequency (MHz)	Average Level (dB μ V/m)	Average Limit (dB μ V/m)	Margin (dB)	Result
2383.974	51.5	54.0	2.5	Complied

Transmitter Band Edge Radiated Emissions (continued)

Results: 802.11b / DQPSK / 2 Mbps

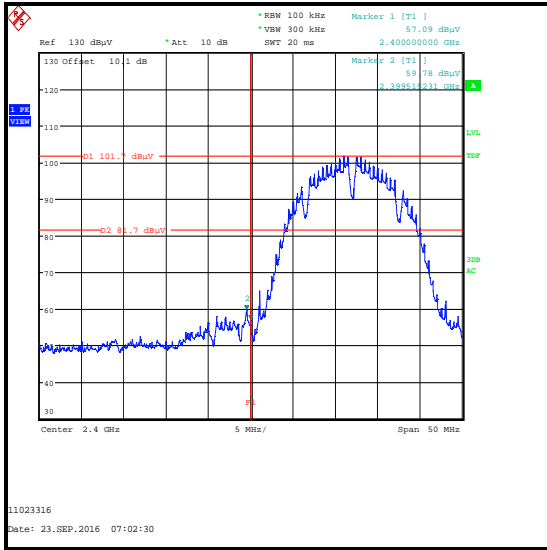

Lower Band Edge Peak Measurement

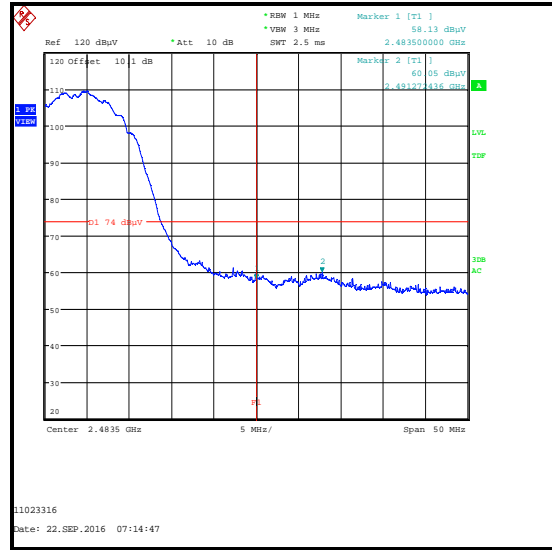

Upper Band Edge Peak Measurement

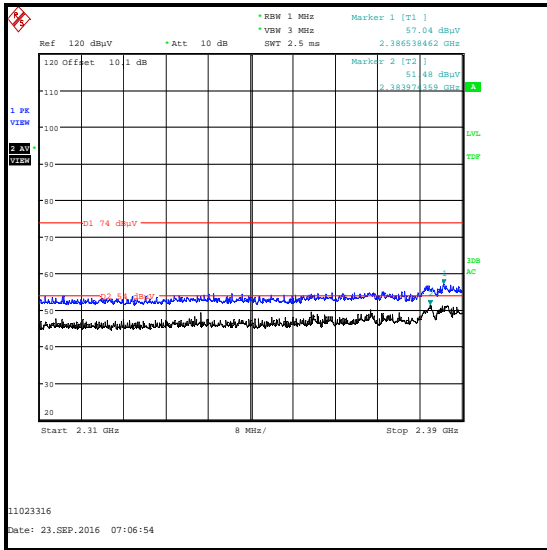

2310 MHz to 2390 MHz Restricted Band

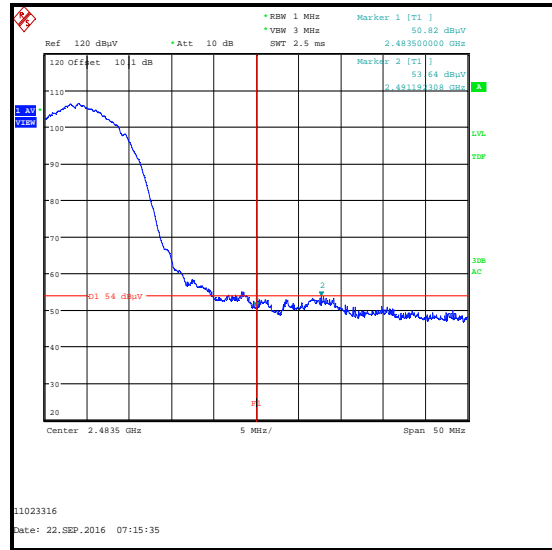

Upper Band Edge Average Measurement

Transmitter Band Edge Radiated Emissions (continued)**Results: 802.11g / QPSK / 12 Mbps / Lower Band Edge**

Frequency (MHz)	Level (dB μ V/m)	-30 dBc Limit (dB μ V/m)	Margin (dB)	Result
2399.840	67.4	69.3	1.9	Complied
2400.000	66.5	69.3	2.8	Complied

Results: 802.11g / QPSK / 12 Mbps / Upper Band Edge / Peak

Frequency (MHz)	Level (dB μ V/m)	Limit (dB μ V/m)	Margin (dB)	Result
2483.500	70.5	74.0	3.5	Complied
2483.580	71.1	74.0	2.9	Complied

Results: 802.11g / QPSK / 12 Mbps / Upper Band Edge / Average

Frequency (MHz)	Level (dB μ V/m)	Limit (dB μ V/m)	Margin (dB)	Result
2483.500	52.4*	54.0	1.6	Complied

Results: 2310 to 2390 MHz Restricted Band

Frequency (MHz)	Peak Level (dB μ V/m)	Peak Limit (dB μ V/m)	Margin (dB)	Result
2386.154	72.6	74.0	1.4	Complied

Frequency (MHz)	Average Level (dB μ V/m)	Average Limit (dB μ V/m)	Margin (dB)	Result
2388.590	51.1*	54.0	2.9	Complied

Transmitter Band Edge Radiated Emissions (continued)

Results: 802.11g / QPSK / 12 Mbps

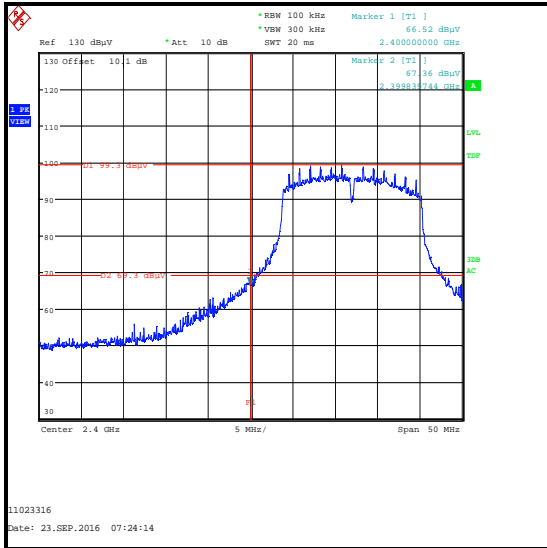

Lower Band Edge Peak Measurement

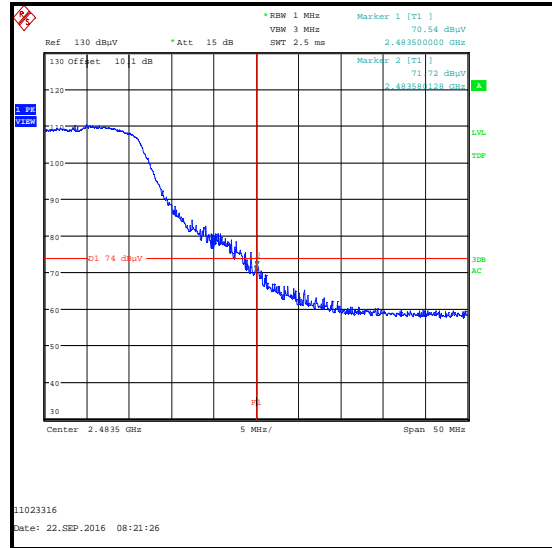

Upper Band Edge Peak Measurement

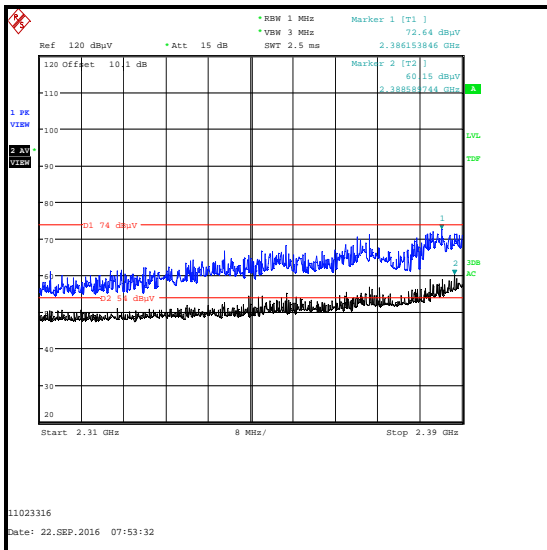

2310 MHz to 2390 MHz Restricted Band

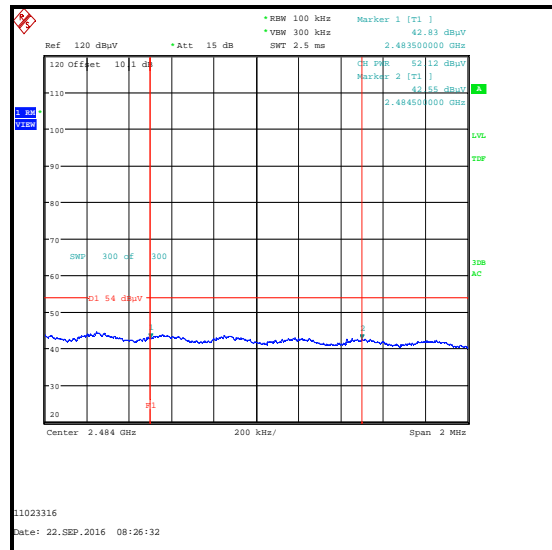

Upper Band Edge Average / Integrated

Transmitter Band Edge Radiated Emissions (continued)

Results: 802.11g / QPSK / 12 Mbps

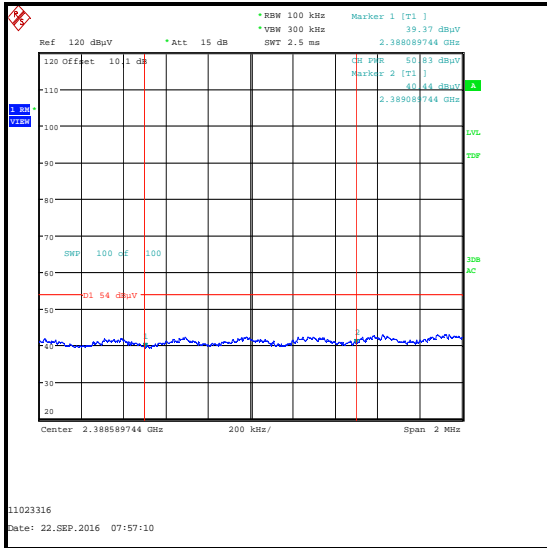

**2310 MHz to 2390 MHz Restricted Band
Average / Integrated**

Transmitter Band Edge Radiated Emissions (continued)**Results: 802.11g / 64QAM / 54 Mbps / Lower Band Edge**

Frequency (MHz)	Level (dB μ V/m)	-30 dBc Limit (dB μ V/m)	Margin (dB)	Result
2400.000	67.9	69.9	2.0	Complied

Results: 802.11g / 64QAM / 54 Mbps / Upper Band Edge / Peak

Frequency (MHz)	Level (dB μ V/m)	Limit (dB μ V/m)	Margin (dB)	Result
2483.500	68.8	74.0	5.2	Complied
2484.702	73.4	74.0	0.6	Complied

Results: 802.11g / 64QAM / 54 Mbps / Upper Band Edge / Average

Frequency (MHz)	Level (dB μ V/m)	Limit (dB μ V/m)	Margin (dB)	Result
2483.500	52.2*	54.0	1.8	Complied

Results: 2310 to 2390 MHz Restricted Band

Frequency (MHz)	Peak Level (dB μ V/m)	Peak Limit (dB μ V/m)	Margin (dB)	Result
2388.333	73.3	74.0	0.7	Complied

Frequency (MHz)	Average Level (dB μ V/m)	Average Limit (dB μ V/m)	Margin (dB)	Result
2389.231	49.7*	54.0	4.3	Complied

Transmitter Band Edge Radiated Emissions (continued)

Results: 802.11g / 64QAM / 54 Mbps

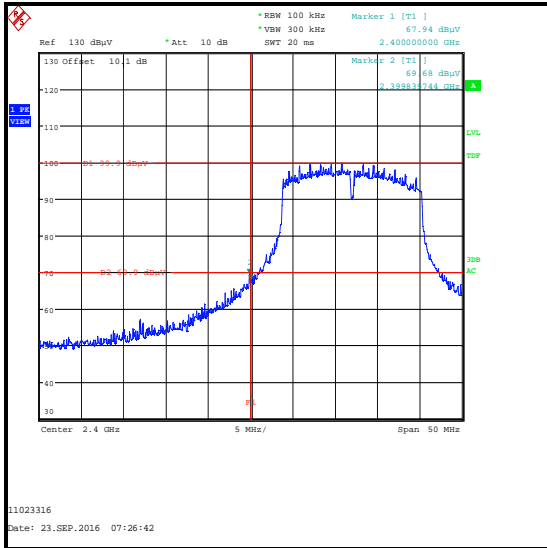

Lower Band Edge Peak Measurement

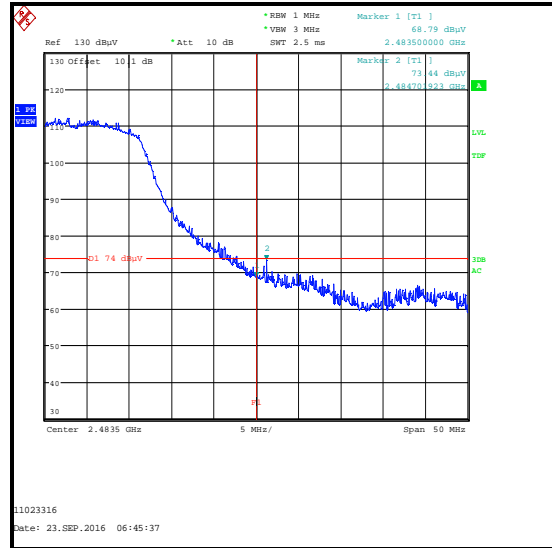

Upper Band Edge Peak Measurement

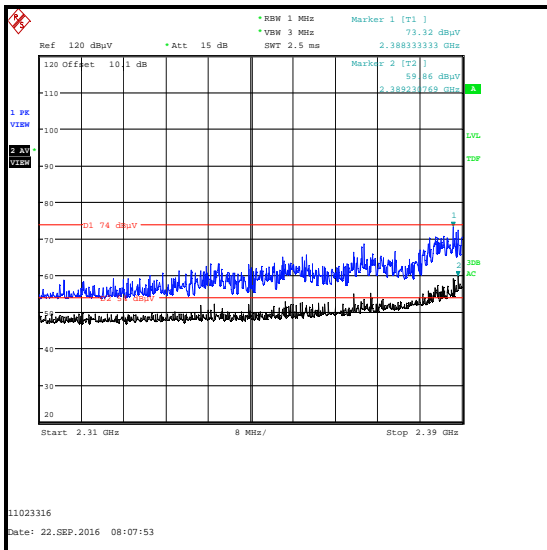

2310 MHz to 2390 MHz Restricted Band

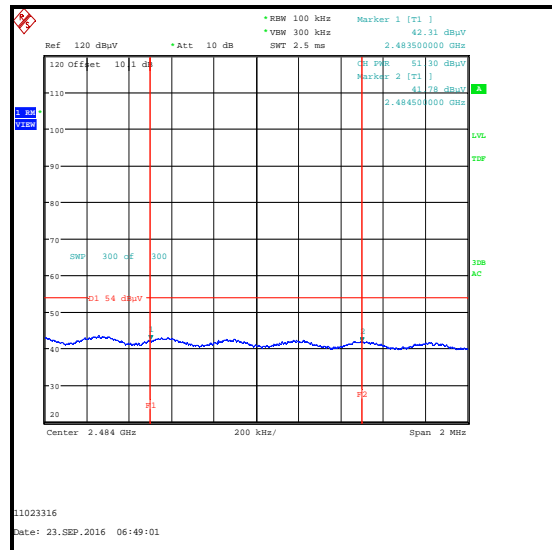

Upper Band Edge Average / Integrated

Transmitter Band Edge Radiated Emissions (continued)

Results: 802.11g / 64QAM / 54 Mbps

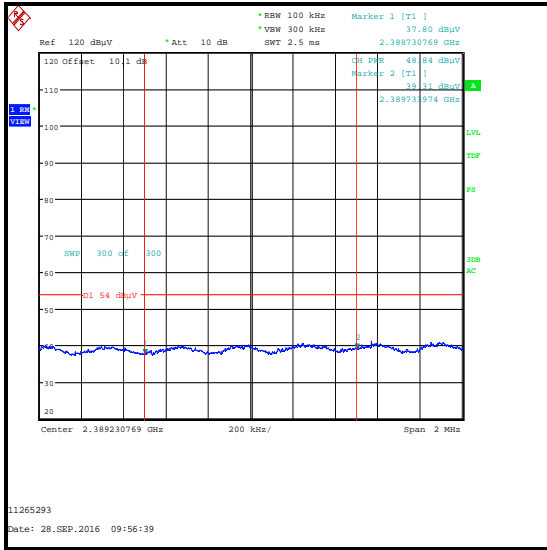

**2310 MHz to 2390 MHz Restricted Band
Average / Integrated**

Transmitter Band Edge Radiated Emissions (continued)**Results: 802.11n HT20 / 16QAM / MCS3 / Lower Band Edge**

Frequency (MHz)	Level (dB μ V/m)	-30 dBc Limit (dB μ V/m)	Margin (dB)	Result
2399.840	68.8	70.2	1.4	Complied
2400.000	67.8	70.2	2.4	Complied

Results: 802.11n HT20 / 16QAM / MCS3 / Upper Band Edge / Peak

Frequency (MHz)	Level (dB μ V/m)	Limit (dB μ V/m)	Margin (dB)	Result
2483.500	70.5	74.0	3.5	Complied
2484.221	71.8	74.0	2.2	Complied

Results: 802.11n HT20 / 16QAM / MCS3 / Upper Band Edge / Average

Frequency (MHz)	Level (dB μ V/m)	Limit (dB μ V/m)	Margin (dB)	Result
2483.500	51.6*	54.0	2.4	Complied

Results: 2310 to 2390 MHz Restricted Band

Frequency (MHz)	Peak Level (dB μ V/m)	Peak Limit (dB μ V/m)	Margin (dB)	Result
2387.436	72.4	74.0	1.6	Complied

Frequency (MHz)	Average Level (dB μ V/m)	Average Limit (dB μ V/m)	Margin (dB)	Result
2389.615	53.5*	54.0	0.5	Complied

Transmitter Band Edge Radiated Emissions (continued)

Results: 802.11n HT20 / 16QAM / MCS3

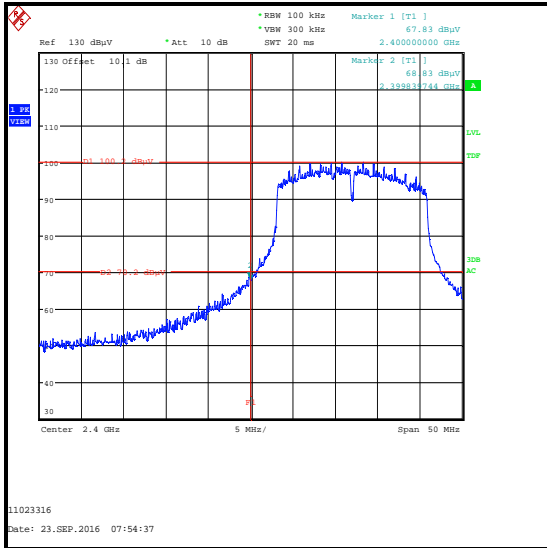

Lower Band Edge Peak Measurement

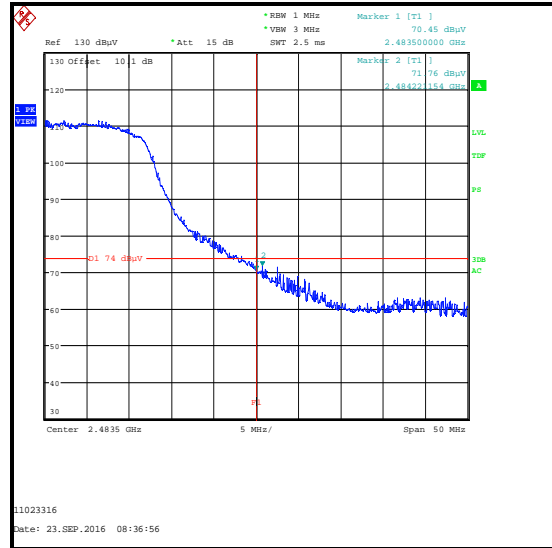

Upper Band Edge Peak Measurement

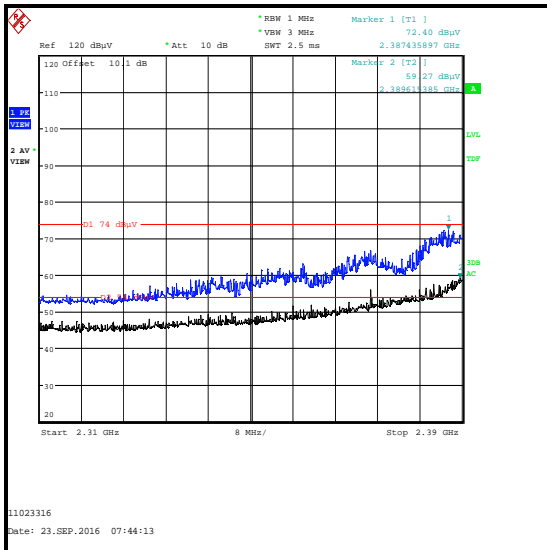

2310 MHz to 2390 MHz Restricted Band

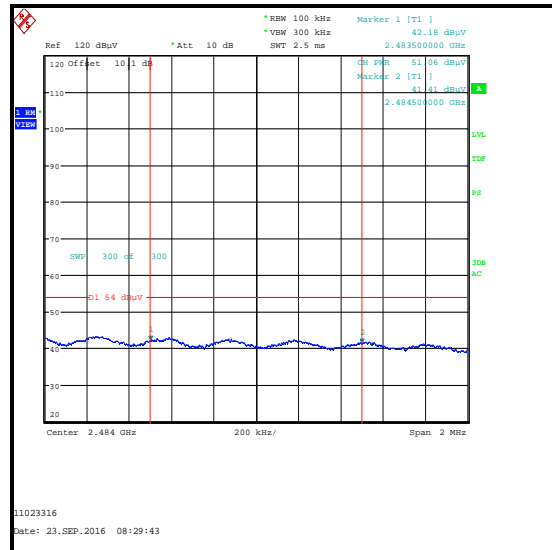

Upper Band Edge Average / Integrated

Transmitter Band Edge Radiated Emissions (continued)

Results: 802.11n HT20 / 16QAM / MCS3

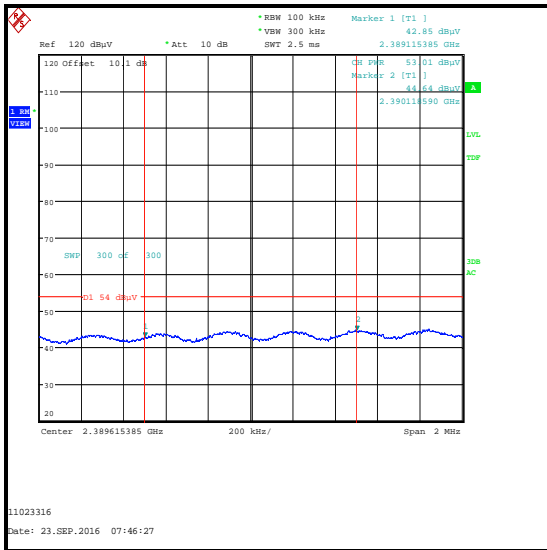

**2310 MHz to 2390 MHz Restricted Band
Average / Integrated**

Test Equipment Used:

Asset No.	Instrument	Manufacturer	Type No.	Serial No.	Date Calibration Due	Cal. Interval (Months)
M2003	Thermohyrometer	Testo	608-H1	45046641	22 Apr 2017	12
K0017	3m RSE Chamber	Rainford	N/A	N/A	17 May 2017	12
M1995	Test Receiver	Rohde & Schwarz	ESU40	100428	21 Mar 2017	12
A2863	Pre-Amplifier	Agilent	8449B	3008A02100	07 Jan 2017	12
A2889	Antenna	Schwarzbeck	BBHA 9120 B	BBHA 9120 B 653	07 Apr 2017	12
A2916	Attenuator	AtlanTecRF	AN18W5-10	832827#1	19 May 2017	12

6. Measurement Uncertainty

No measurement or test can ever be perfect and the imperfections give rise to error of measurement in the results. Consequently the result of a measurement is only an approximation to the value of the measurand (the specific quantity subject to measurement) and is only complete when accompanied by a statement of the uncertainty of the approximation.

The expression of uncertainty of a measurement result allows realistic comparison of results with reference values and limits given in specifications and standards.

The uncertainty of the result may need to be taken into account when interpreting the measurement results.

The reported expanded uncertainties below are based on a standard uncertainty multiplied by an appropriate coverage factor such that a confidence level of approximately 95% is maintained. For the purposes of this document "approximately" is interpreted as meaning "effectively" or "for most practical purposes".

Measurement Type	Range	Confidence Level (%)	Calculated Uncertainty
Minimum 6 dB Bandwidth	2.4 GHz to 2.4835 GHz	95%	±4.59 %
Duty Cycle	2.4 GHz to 2.4835 GHz	95%	±1.14 %
Spectral Power Density	2.4 GHz to 2.4835 GHz	95%	±1.13 dB
Conducted Maximum Output Power	2.4 GHz to 2.4835 GHz	95%	±1.13 dB
Radiated Spurious Emissions	30 MHz to 1 GHz	95%	±5.65 dB
Radiated Spurious Emissions	1 GHz to 25 GHz	95%	±2.94 dB

The methods used to calculate the above uncertainties are in line with those recommended within the various measurement specifications. Where measurement specifications do not include guidelines for the evaluation of measurement uncertainty the published guidance of the appropriate accreditation body is followed.

7. Report Revision History

Version Number	Revision Details		
	Page No(s)	Clause	Details
1.0	-	-	Initial Version
2.0	1 6	- -	Changed Model No. to v1.1 Changed Model No. to v1.1 & Brand name to Raspberry Pi Zero W

--- END OF REPORT ---